

In honor of
The Explosives and Weapons Forum

We present:
The Encyclopedia of Explosives and Related Items

PATR 2700, the Encyclopedia, Federoff, the Bible of Explosives, call it what you will as it has many names. There are few enough books in existence that cover a topic such as explosives, let alone do such a good job as to be a must have reference for anyone in the field. The Encyclopedia is the single greatest work on explosives period. Get it, copy it, distribute it far and wide.
A special thanks goes to megalomania for creating The Forum, to NBK2000 for keeping out the kewls, and to nhamilto40 for ripping the original of this book.



<http://www.roguesci.org>

All the knowledge "they" don't want you to have

Visit The Forum at <http://www.roguesci.org/theforum/index.php>

Visit the Chem Lab at <http://www.roguesci.org/megalomania>

ENCYCLOPEDIA OF EXPLOSIVES AND RELATED ITEMS

PATR 2700

VOLUME 9

BY
SEYMOUR M. KAYE

ASSISTED BY
HENRY L. HERMAN



U.S. ARMY RESEARCH AND DEVELOPMENT COMMAND
TACOM, ARDEC
WARHEADS, ENERGETICS AND COMBAT SUPPORT CENTER
PICATINNY ARSENAL
NEW JERSEY, USA

1980

Copies of the "Encyclopedia of Explosives
And Related Items" can be obtained by requesting CD ROM
from the:

National Technical Information Service
(formerly Clearinghouse)
US Department of Commerce
Springfield, Virginia 22151

1-800-553-6847 USA only
703-605-6000
www.ntis.gov/FCPC

The contents of these volumes are UNCLASSIFIED

The distribution of these volumes is UNLIMITED

Neither the US Government nor any person acting on behalf of
the US Government assumes any liability resulting from the use or
publication of the information contained in this document or warrants
that such use or publication will be free from privately owned rights.

All rights reserved. This document, or parts thereof, may not be
reproduced in any form without written permission of the
Energetics and Warhead Division, WECAC, TACOM, ARDEC, Picatinny Arsenal

Library of Congress Catalogue Card Number: 61-61759

PREFACE

This volume represents a continuing effort to cover comprehensively the unclassified information on explosives and related subjects in the same manner and format as in previous volumes. The reader is urged to obtain the previous volumes and to read both the PREFACE and INTRODUCTION in Volume I in order to understand the authors' way of presenting the subject matter

In preparation for and during the writing of this Encyclopedia, the authors have consulted freely with and have had the cooperation of many individuals who contributed their expert knowledge and advice. This fact is acknowledged throughout the text at the end of the subject item. A listing of many others who have helped in various ways would be impractical

Drs J. Roth, A. P. Hardt and S. Greenberg of the private sector, Dr D. H. Rosenblatt of the US Army Medical Bioengineering Research and Development Laboratory, Fort Detrick, Md, as well as Dr E. E. Gilbert and Messrs S. Helf, L. Avrami and T. C. Castorina of the Energetic Materials Division, LCWSL, ARRADCOM, Dover, NJ, all contributed significantly in the literature searching and writing of many of the articles in this volume. In addition, Ms R. Meredith, P. Altner, M. Richards, J. Blodgett, M. Ng, E. Ragolski and Mr A. Farnell of STINFO Division (Library), Messrs A. Anzalone and L. Silver of PLASTECH, all of ARRADCOM, Dover, NJ, gave unstintingly of their time and effort in such diverse supporting tasks as computerized searches and retrievals, *Beilstein* and *Gmelin* manual searches, and publication procurement, translation and reproduction services

Dr Raymond F. Walker, Energetic Materials Division Chief, provided financial support and encouragement to continue this work, as did Mr Edward J. Kolb of Headquarters, US Army Materiel Development and Readiness Command (DARCOM). Further financial support was received from the sale of volumes to non-government agencies and individuals by the National Technical Information Service, US Department of Commerce, Springfield, Va 22161

Although considerable effort has been made to present this information as accurately as possible, mistakes and errors in transcription and translation do occur. Therefore, the authors encourage readers to consult original sources, when possible, and to feel free to point out errors and omissions of important work so that corrections and additions can be listed in the next volume. The interpretations of data and opinions expressed are often those of the authors, and are not necessarily those nor the responsibility of officials of ARRADCOM or the Department of the Army

This volume has been prepared for information purposes only and neither ARRADCOM nor the Department of the Army shall be responsible for any events or decisions arising from the use of any information contained herein

In conclusion, I wish to acknowledge with gratitude the continual support and encouragement of Samuel Helf, without whose efforts in behalf of the Encyclopedia of Explosives program, the publication of this volume would not have been possible

Seymour M. Kaye
Dover, New Jersey
October 1980

TABLE OF CONTENTS

	Page
Preface	I
List of Tables	III
List of Figures and Illustrations	VIII
Supplement to Abbreviations for Books and Periodicals	XII
Supplement to List of Books on Explosives, Propellants, Pyrotechnics and Ordnance Items	XIII
 Descriptive Text of Encyclopedic Items	
QDX (SEX) to Quinonemonoxime and Derivatives	Q 1 to Q 6
Rabinet to Ruthenium Tetroxide	R 1 to R 203
S1 and S2 to Sytamit	S 1 to S 265
T ₁ , T ₂ and T ₃ to Type Explosives	T 1 to T 416

III

LIST OF TABLES

	Page
Slow Neutron Irradiation of Primary Explosives	R 8
Fission-Fragment of Explosive Azides	R 9
Weight Loss by Reactor Irradiated Explosives	R 14
Effects of Reactor Irradiation on Some Explosives	R 15
Weight-Loss Summary	R 21
Compositions Used in Caliber .30 Percussion Primers	R 26
Pulsed Reactor Irradiation of Lead Azide-Boron Mixtures	R 28
Summary of Data Obtained from Explosives After Exposure to γ -Radiation	R 30
Effect of Co^{60} Gamma Radiation on Explosives by PicArSn Impact Sensitivity Test	R 34
Effect of Gamma Radiation on the Rates of Detonation for Explosives	R 36
Effect of Gamma Irradiation on Various Lead Azides	R 40
Effects of 60-MeV Electron Irradiation on Explosives	R 44
Critical Doses and Temperatures to Initiate Explosives by Pulsed High-Energy Electrons	R 45
Initiation of Lead Azide by Pulsed Electrons	R 46
Ranges of Approx 0–25MeV Protons in Various Explosives	R 48
Minimum Ignition Energies of Explosives by Light Flashes	R 49
Light-Flash Ignition Energies for Azides and Mixtures	R 51
Effects of Reactor Irradiation on Some Composite Propellants	R 56
Estimates of Radiation Effects on Polymers	R 63
Commercially Available Gamma-Ray Sources	R 78
Gamma-Ray Absorption Coefficients for Elements, 0.015–0.125MeV	R 80
Gamma-Ray Absorption Coefficients for Elements 0.30–1.25MeV	R 80
Gamma-Ray Absorption Coefficients for Explosive Compounds and Compositions 0.015–0.125MeV	R 81
Gamma-Ray Absorption Coefficients for Explosive Compounds and Compositions, 0.30–1.25MeV	R 81
Fast and Thermal Neutron Properties of Elements	R 83
Comparison of Composition of Cellulose with that of Bond Paper and Some Common Explosives	R 99
Fast Neutron Moderation and Thermal Neutron Transmission for Charge Weight Measurement	R 101
Propellant Level Gauging with Neutrons	R 103
Adsorption of High M.W. Compounds on Powdered Explosives	R 108
Isotope Dilution Analysis of HMX in HMX/RDX Mixtures	R 110
Maximum Detection Distances for Location of Scandium-46 Tagged Ammunition Items	R 112
Detonation Parameters of RDX Mixed with Liquids of Different Densities	R 125
Physical Properties of Solid Additives and 50% Heights of RDX Compositions	R 128
Kinetic Data for the Decomposition of RDX at 212°	R 137
Effect of Formaldehyde Hydroxymethyl Formamide, Methylene Difformamide and 1,3,5-Trinitrobenzene	R 138
High Explosive Reclamation	R 147
Propellant Reclamation	R 148
Pyrotechnic Reclamation	R 149
Calcium Resinate – Chemical and Physical Properties	R 158
German Roburites	R 176
Toxicological Properties of Selected Explosives	S 10
Comparison of Safety Classifications	S 12
American Table of Distances for Storage of Class 1.1 Explosives	S 13

List of Tables (Continued)	Page
Molecular Structure as a Guide to Hazard Assessment	S 15
Illustrative Kinetic Thermal and Geometric Parameters	S 24
Department of Defense Explosives Safety Board (DDESB) Proceedings of the Annual Explosives Safety Seminars	S 29
Salicylic Acid Specification Requirements	S 31
Confined Detonation Velocity and Borehole Loading Density of AN-FO	S 44
Values of Acceleration in Ammunition	S 53
Temperatures Reached by Air When Compressed Adiabatically	S 54
Critical Setback Pressures of Explosives of Various Base Separations	S 54
Shock Sensitivity of TNT	S 68
Effect of Shock Geometry on Shock Sensitivity	S 72
Literature Shock Sensitivity Data	S 73
Shock Sensitivity of Homogeneous Explosives	S 75
Shock Initiation Criteria	S 76
Comparison of Pressure at Which Burning is Just Detectable in the Underwater and Modified Gap Tests	S 82
Silica Gel Specification Requirements	S 89
Calcium Silicates	S 91
Calcium Silicates Specification Requirements	S 91
Sodium Silicates	S 92
Calcium Silicide, Chemical and Physical Requirements	S 94
Calcium Silicide Granulation Requirements	S 95
Silicon, Chemical Requirements	S 98
Silicon, Granulation Requirements	S 99
Ferrosilicon Powder Explosion Parameters	S 100
The Heat and Products of Detonation of Heavily Confined Charges of XTX-8003	S 102
Properties of Plastic Bonded HMX	S 104
16.0-Inch Diameter Star Cavity Cast Flare	S 106
Properties of Siloxanes	S 107
German "Synoxyd" Formulations	S 112
Standard LLL-Pantex Skid Test with Hemispheres of Explosive	S 114
Nonstandard Skid Tests	S 116
Evaluation of Plant Floorings by LLL-Pantex Test	S 118
Water Gels and Slurries Consumption by Use	S 122
Trade Names of US Commercial Slurries	S 123
Qualitative Comparison between Slurry Explosives and Dynamites	S 124
Classes of Well-Characterized Slurry Explosives and Slurry Blasting Agents	S 126
Slurry Ingredients	S 126
Detonation Characteristics of Selected Commercial Slurry Explosives	S 129
Influence of Detonating Cord Downlines on Energy Release of SBA and ANFO	S 135
Fumes from DBA-2 and DBA-3 Taken Immediately after Blast in Unventilated Mine	S 137
Data from Bureau of Mines Reports on IREMITE Fume Studies	S 138
Patent List – Slurry Explosives	S 139
Qualitative Solubilities of Pure Explosives	S 154
Qualitative Solubilities of Additives and Binders	S 155
Solubility of RDX	S 156
Solubility of HMX	S 156
Solubility of HNS	S 156
Solubility of DATB	S 156

List of Tables (Continued)	Page
Solubilities of Explosives in Dimethylformamide	S 156
Comparison of Solubilities After 5 and 10 Minutes of Stirring at 25°C	S 156
Properties of Hexanitrosorbitol	S 159
Sound Velocities Through Explosives	S 162
Spanish Infantry Weapons in Current Service	S 176
Electromagnetic Spectrum	S 179
Characteristics of Simple Chromophoric Groups	S 185
Characteristic Infrared Absorptions of Functional Groups	S 188
USA Military Specification Requirements for "Sugar, Refined and Brown: Beet or Cane"	S 231
Antimony Sulfide – Chemical and Granulation Requirements	S 236
Properties of Molecular Sulfur	S 242
Composition and Parameters of an Optimum Gas Generating Composition for Gas Dynamic Laser Studies	S 244
Chemical Requirements for Sulfur	S 245
Physical and Chemical Requirements of Sulfuric Acid	S 249
Swedish Weapons in Current Service	S 261
Swiss Weapons in Current Service	S 265
Data Obtained Using an Acceptor Wall Thickness of 0.46 Inch	T 1
Shock Pressure Sensitivity for TACOT-Z Acceptor Charge	T 1
Minimum Bombing Incidents Statistics Summary	T 4
Comparison of Predicted and Observed Bombing Trends	T 5
Bombings by Specific Targets for 1977–78	T 6
Explosive Fillers Used in Criminal Bombings	T 6
Candidate Vapor Taggant Properties	T 14
Physical Properties and Toxicology Data for Potential Vapor Taggants	T 15
Percent of Bomber Targets That Would Be Protected by a Detection Sensor	T 16
Vapor Taggant Detector System Cost	T 19
Taggant Program Summary	T 22
Taggant Program Summary	T 23
Summary Program Costs	T 23
Comparison of the Estimates for ID Tags	T 24
Identification Taggant Material Annual Costs	T 25
Detection Taggant Material Annual Costs	T 25
Manufacturing Cost Added	T 26
Distribution System Cost Added	T 26
Tantalum Gasless Delay Compositions	T 30
Amination Results	T 36
Properties of TATB	T 38
Pressed Compositions	T 46
Castable Compositions	T 49
TKA – A High Temperature Propellant Containing TATB	T 52
Detonator Delay Compositions Containing Te	T 62
Tensile Strengths of Typical Explosives	T 64
Dynamic and Static Tensile Strengths	T 66
Standard Ammonium Perchlorate Double-Base Propellant	T 74
Melting Points of Various Mixtures of TeMeAN with AN	T 76
Explosive Parameters of Mixtures of TeMeAN with AN and RDX	T 76
Explosive Compositions Containing TeMeAN, AN and Na Nitrate	T 77
Thermal Stabilities, Melting Points, and Impact Sensitivities of Six Isomeric Tetranitrobiphenyls	T 82

List of Tables (Continued)	Page
Physical Properties and Configuration of Baseline System	T 87
Parameter Values for Variation of DDT Characteristics	T 88
Vapor Pressure of β -HMX	T 90
β -HMX Activation Energies	T 90
The Confidence Level (K) that Coarse HMX is Sensitized by Air-Borne Grit	T 91
Underwater Detonation Data for HMX	T 91
Thermodynamic Values for HMX	T 92
Composition and Properties of Flexible Sheet Explosive Containing HMX	T 94
Time to First Flame Ignition of Oxamide-Containing HMX Propellants	T 97
Compositions and Properties of Two Temperature-Resistant Propellants	T 98
TNT Equivalency of Tetrazene	T 105
Unit Cell Dimensions and Space Groups of Some Amino-Tetrazole Compounds	T 116
Impact Sensitivity, Hot Bar Ignition Temperature and Vacuum Stability	T 117
5-Amino Tetrazole Derivatives	T 117
Heat Stability Tests on Double-Base Propellants Containing Tetrazoles	T 119
Preparation of 5-ATZ Salts	T 120
Ignition Properties of Some 5-ATZ Metal Salts	T 120
Energetic Properties of GNAT	T 122
Impact Sensitivity of Various Metal Bis-5-Azo-Tetrazole Salts	T 127
Sensitiveness of Products and Evaporation Residues of Bis-5,5'-Azotetrazole	T 128
Safety Data of Mercuric-5-Nitrotetrazole and Its Intermediates	T 137
Composition of Gaseous Products of Tetryl Decomposition	T 154
Composition of Condensed Phase (160°)	T 154
Observed and Computed Detonation Product Compositions	T 157
Plane-Wave Shock Initiation Threshold for Tetryl	T 158
Gap-Test Initiation Thresholds for Tetryl	T 159
Critical Energies Calculated from Projectile Impact Data on Tetryl	T 161
General Characteristics of Tetrytols	T 165
Properties of the Thallium Picrate Enantiotropes	T 169
Explosives and Binders: Coefficients of Thermal Expansion, Glass Transition Temperatures, and Pressed Densities	T 171
Critical Values for Thermal Explosion Parameters	T 176
Critical Radius for Thermal Explosion of Tetryl	T 182
Critical Diameter and Adiabatic Explosion Time for RDX	T 185
Kinetic Parameters of Cellulose Nitrate and Polyvinyl Nitrate Thermal Decomposition	T 186
Thermal Properties of Selected Explosives	T 191
Thermochemical Data Sources for Pyrotechnic Reactions	T 202
Ideal Gas Free Energy Functions for Detonation Products	T 213
Possible Rationale for the Near-Equivalence of Calorimetric and Computed Heats of Detonation	T 215
Fuel Syrups Supplied by Resin Research Laboratories	T 221
Cure Data on Fuel Syrup Polymers	T 221
Burning-Rate Tests of Pyrotechnic Mixtures Containing in Situ Polymerized Fuel Syrup	T 221
General Characteristics of Timers	T 226
Parameters of Igniter-Propellant Compositions Incorporating Titanium	T 228
Titanium Containing Pyrotechnic Formulations	T 228
US Military Requirements for Powdered Titanium	T 229
Impurities Present in TNT Prepared by Continuous Nitration and Purification	T 244
TNT Complexes	T 256
Specific Heat, Heat Content and Entropy Data	T 262

List of Tables (Continued)	Page
Concentration and Destruction Methods for TNT	T 277
Accidents Involving TNT	T 281
Principal Composite Explosives Containing TNT	T 282
TNT Isomers	T 284
Rate Constants of Reactions of Nucleophiles with Trinitroaromatic Compounds	T 286
Effects of Toluene Vapor	T 300
Selected Properties of Ortho- and Para-Mononitrotoluenes	T 303
Selected Thermochemical and Energetic Properties of Ortho- and Para-Mononitrotoluene	T 304
Selected Properties of the Dinitrotoluene Isomers	T 305
Solubility in Selected Solvents of 2,4-Dinitrotoluene	T 307
Nitration of Nitrotoluene Isomers	T 308
US Military Specification for Dinitrotoluene	T 311
Examples of European Mining Explosive Compositions Containing Dinitrotoluene	T 312
Control of the Detonation Velocity of Sprengel Type Explosives	T 312
Synthesis and Properties of the Dinitrotoluidines	T 321
Torpedoes	T 325
DuPont Water Gels	T 330
Reported TNT Metabolites	T 333
"Synthetic" Condensate Wastewater Mixture	T 335
Acute Toxicity of DNT Isomers to Two Aquatic Species	T 340
Specific Properties of Various Explosive 1,2,3-Benzotriazinium Betaine-1,4-Oxides	T 354
Specific Properties of Various Explosive 5H-Imidazo [4,5-d] 1,2,3-Triazine-4 (3H)-Ones	T 355
Specific Properties of Various Explosive 7H-Imidazo [4,5-d] 1,2,3-Triazine-4 (3H)-Ones	T 356
Properties of TNB/TNT and Tetryl/TNB Mixtures	T 376
The Explosive Properties of Selected 2,4,6-Trinitrobenzene Derivatives	T 376
Impact Sensitivities and Oxidant Balances of Polynitroaromatic Explosives	T 379
Effect of PbO on the Rate and Composition of the Products in the Decomposition of NG	T 387
Physical Properties of Tungsten	T 402
Mechanical Properties of Tungsten	T 403
Gasless Delay Compositions in Current Use	T 406
Heats of Reaction of Tungsten in Inorganic Mixtures Considered for Delays	T 406
Burning Rates of Various Tungsten Delay Compositions	T 406
Variations of Burning Rate due to Change in Particle Size of Tungsten Delay Composition	T 406
Effect of Varying Both the Zinc Stearate and Barium Chromate Content on the Burning Rate and Temperature Coefficient of a Tungsten Delay Composition	T 410
Environment Surveillance of a Tungsten-Viton Composition	T 411
Evaluation of Mk 279 Mod Igniters Containing Tungsten-Viton Delay Composition Over a Four Year Timespan	T 411
Comparison of Sensitivity and Physico-Chemical Characteristics of First Fire Compositions	T 411
Maximum Allowable Metallic Impurities in Tungsten Powder	T 412
Distribution, Weight Percent	T 413

VIII

LIST OF FIGURES AND ILLUSTRATIONS

	Page
Closed Bomb Record	Q 4
Apparatus for Continuous Dosage of Acid and Glycerin	R 1
Flow-Sheet of Continuous Method of Manufacture of Nitroglycerin	R 2
Range-Energy Relation for Protons and α -Particles in Several Explosives	R 7
Effect of Slow Neutron Irradiation on the Subsequent Thermal Decomposition of Lead Azide	R 9
Thermal Decomposition Curves of Reactor-Irradiated Pb Styphnate Monohydrate	R 11
Effect of Reactor Irradiation on Impact Sensitivity, Colloidal Pb Azide	R 12
Effect of Reactor Irradiation on the Thermal Decomposition of Colloidal α -Pb Azide	R 13
Weight Loss of Primary and Booster Explosives as a Function of Reactor Irradiation	R 23
Weight Loss of Main-Charge Explosives as a Function of Reactor Irradiation	R 24
Effects of Reactor Irradiation on Explosion Temperature of TATB	R 25
Gas Evolution by Gamma-Irradiated Explosives at Ambient Temperature	R 31
Gas Evolution by Irradiated Dextrinated Lead Azide at Different Temperatures	R 32
Apparent Radiation Damage to Standard Components	R 32
Weight Loss of Co ⁶⁰ Irradiated Pellets	R 35
Effect of Gamma Radiation on the Detonation Velocity of Explosives	R 37
DTA Thermograms for BaN ₆ as a Function of Gamma Dose	R 39
Formation of Ammonium Nitrate on Top of Irradiation Explosion Proof Capsule Containing Lead Azide	R 41
Variation of Time to Explosion with Preirradiation X-Ray Dosage for Decomposition at 298°C	R 43
Effect of Ultraviolet Irradiation on Induction Time, 50% Point, and Activation Energy of Colloidal Lead Azide	R 49
Sensitization of Silver Azide to Light due to the Effect of Gold Particles	R 50
Relationship Between Light Energy for Ignition and Temperature for Lead Azide	R 51
Variation of the Minimum Light Energy for Ignition of Lead Styphnate with Ambient Temperature	R 52
DTA of Ammonium Perchlorate Showing Effect of Reactor Irradiation	R 54
Relative Radiation Stability of Propellants	R 58
Weight Loss of Propellants as a Function of Reactor Irradiation	R 59
Induction Period vs Total Dose Data for Irradiated and Unirradiated Ammonium Perchlorate Single Crystals	R 64
Effects of Gamma-Ray ²³⁵ U Fission Spectrum Neutron, and Combined Gamma-Ray and Neutron Irradiation on Whole Crystals of Ammonium Perchlorate	R 65
Generalized Concept of Gamma-Ray Gauging	R 77
Simplified Illustration of Neutron Gauging	R 82
Gamma-Ray Feedback Transducer System for Propellant Burning Rate Measurement	R 85
Gamma-Ray Transmission Gauge for Burning Rate Measurement in Rocket Motors	R 86
Relative Propellant Thickness vs Burning Time Using Gamma-Ray Transmission Gauge	R 88
Sketch of Gamma-Ray Density Scanner	R 89
Typical Gamma-Ray Densitometer Scan of an M-55 Detonator	R 90
Improved Gamma-Ray Scanning Gauge for Detonators	R 91
Electrical Ignition Element	R 92
Block Diagram of Gamma-Ray Measuring Equipment	R 93
Sketch of Gamma-Ray Transmission Gauge for Base Separation Detector	R 94
Conceptual Sketch of a CT Explosives Detector	R 96
Drawing of Projected AIDECS System in Operation at a Loading Plant	R 97
Top Cross-Section Sketch of Fast Neutron Gauging	R 99

List of Figures and Illustrations (Continued)	Page
Relative Counts as a Function of Moisture Content for Powdered Materials by Fast Neutron Gauging	R 100
Sketch of Thermal Neutron Transmission Gauge for Measurement of Charge Weight	R 101
Measurement of Charge Weight of RDX in a Brass Cylinder by Thermal Neutron Gauging	R 101
“Neutron Weighing” of Propellant in 30mm Cartridge Case	R 102
“Neutron Weighing” for Charge Weight in .50 Cal Percussion Primers	R 102
Typical Curve for Normalized Krypton Concentration vs Amount of Propellant in Tank	R 106
Adsorption Isotherm of Carbon-14 STAB on HMX in 90/10 Water-Ethanol at 30°C	R 109
Specific Heat C_p of RDX as a Function of Temperature	R 122
Linear Coefficients of RDX	R 122
Steady-State Detonation Velocity of RDX vs Charge Diameter	R 124
Output of RDX Particle Sizes	R 131
Sensitivity of Granular RDX	R 132
Effect of Charge Density on the Stability of the Normal Burning of RDX	R 134
Distribution of Temperature and Relative Intensities of OH, C ₂ , CN, CH, H ₂ , O ₂ and N ₂ with Height Along an RDX Flame	R 134
Proposed DDT Mechanism for 91/9 RDX/Wax Granular Charge	R 135
Concentration-Time Profiles of N ₂ O, CO ₂ and NO ₂ for Three Reactor Volumes	R 136
Concentration-Time Profiles of NO ₂ for Various Initial Weights of RDX and Reactor Volumes . .	R 136
The Systems RDX-Rosin and RDX-Urea	R 140
Principles of Recoilless Rifles	R 151
Typical Explosive Relays	R 156
Early Hand Weapons – Colt Cal .45 and .38 Revolvers	R 163
Sectional View of Pistol M1911A1	R 164
Mechanism of a Wheel Lock and Key for Winding It	R 169
Bullet Spun by Rifling	R 170
Expanding Bullet as Loaded in Gun	R 171
Rifling Details	R 173
External Charge of the ZKP Type with a Spherical Shaped Recess for Secondary Blasting	R 196
Sabot in Gun Tube	S 1
Schematic Pressure-Time Curves for Deflagration, High Order Detonation	S 14
Biomedical Criteria for Primary Blast Effects on Humans	S 20
Ignition of Composite Solid Propellants by Impact	S 25
Typical Time-Acceleration Curve for Projectile While in Gun	S 53
Apparatus Which Simulates Setback Pressure	S 54
Transmission of a Plane Shock Wave Into a Material of Lower Impedance	S 60
Transmission of a Plane Shock Wave Into a Material of Higher Impedance	S 60
Charge Assembly and Dimensions for NOL Standardized Gap Test	S 62
Complete SSGT Setup	S 62
Schematic Cross Section of the Gap Test	S 63
Schematic Diagram of the LASL Wedge Slant System	S 63
Schematic Representation of a Streak Camera Record of a Wedge Shot	S 64
Streak Camera Record from Wedge Shot	S 64
Two Stages Set-Up for the Study of Granular Explosive	S 64
Principle of Generation of Rectangular Pressure Pulses	S 65
Schematic Diagram of a Gas Gun-Flyer Plate System	S 65
Explosive Wedge Experiment	S 66
Sensitivity of Composition B-3	S 69
Shock Sensitivity of Five Explosives	S 69

List of Figures and Illustrations (Continued)	Page
Effect of Initial Density and Initial Temperature on the 50% Threshold of HNS	S 69
Shock Sensitivity Curves for Waxed and Unwaxed Ammonium Perchlorate and for TNT	S 70
Effect of Interstitial Gas Pressure on the Small-Scale Gap-Test Sensitivity of Low Specific Surface PETN	S 71
Blackbody Temperature-Time Plots for Two Bare Charge Shots	S 76
Typical Impact-Face Pressure Histories Measured with Quartz Gauges	S 77
Relationship Between Distance to Detonation and Initial Shock Pressure for Various Explosives	S 78
Interface Deceleration Curves	S 79
Sensitivity of Granular RDX	S 80
Sensitivity of Liquid and Solid TNT and Nitromethane	S 81
Sliding-Block Friction Apparatus	S 119
Detonation Velocity of a TNT Slurry as Function of Distance from the Primer	S 128
Effect of Specific Gravity on Volume Energy of NCN or Explosive-Sensitized Slurries at 40°F . .	S 130
Effect of Pressure on Volume Energy on one Type of NCN Slurry	S 131
Effect of Borehole Temperature on Energy-Density Relationship of a Typical Nonmetallized NCN Slurry	S 131
Comparison of Density-Sensitiveness Curves for SE and SBA	S 133
Reciprocal Critical Diameter (or Sensitiveness) vs Percent TNT Curves for SE-TNT	S 134
Effect of Detonating Cord on NCN Slurries Potential Energy Loss	S 136
Sound Suppressors (Schematics)	S 161
The Electromagnetic Spectrum	S 180
Spectral Distribution of Black Body Radiation as a Function of Temperature	S 181
Percentage of Black Body Radiation as a Function of Wavelength and Temperature	S 182
Effect of Emissivity on Radiant Output	S 183
Ultraviolet Absorption Spectrum of Benzene	S 184
Normal Vibrational Modes of CO ₂ and H ₂ O	S 187
Typical Piston Primed Single Flechette Cartridge	S 199
SPIW/Flechette Ammunition	S 201
Cross-Section Through a Squib	S 206
Diagram of a Typical Strand Burner	S 219
The HDP Supergun	S 251
Arrow Projectiles Fired by the HDP Supergun	S 252
The Susan Projectile	S 253
Susan Test: TNT	S 254
Susan Test: Cyclotol 75/25	S 254
Susan Test: Comp B-3	S 255
Susan Test: Octol 75/25	S 255
Explosives Used in Criminal Bombings	T 7
Bombing Casualties as a Function of Explosives Used	T 7
The 3M Company Color-Coded Taggant	T 10
Detection Taggants Sensor System Block Diagram	T 16
Ion Mobility Spectrometer System	T 18
General Functional Network for Vapor Taggant Detector	T 19
Estimated Annual Vapor Taggant Detector Cost vs Quantity Deployed	T 19
Schematic Illustration of Identification Taggant Utility in Criminal Investigation	T 21
Schematic Illustration of General Cost Element Sources	T 22
Configuration of the TATB Molecule	T 37
Phase Velocity Data	T 49
Attenuation Data	T 49
Infrared Scan of TATB	T 51

List of Figures and Illustrations (Continued)	Page
Typical VHF High-g Telemetry System	T 60
Sequence of Events	T 61
Drawing of β -HMX Molecule Showing Interatomic Distances and Angles	T 84
Stereoscopic Views of α -HMX and δ -HMX	T 85
Time to Explosion for HMX	T 86
Variation of Runup Distance with Particle Diameter	T 89
Variation of Runup Length with Porosity	T 89
Effect of HMX Particle Size in HTPB Propellant	T 95
75% HMX in Polyurethane Propellant	T 95
85% HMX in CTPB Propellant	T 96
Arc-Image Ignition Data for HMX Composite Propellants	T 97
Equipment for Preparing $\text{Cu en}_2(\text{NT})_2$ and $\text{Hg}(\text{NT})_2$	T 136
Hydraulic Transfer of $\text{Hg}(\text{NT})_2$	T 137
Kinetic Gas-Evolution Curves in the Decomposition of Tetryl	T 153
Kinetic Gas-Evolution Curves in the Decomposition of Tetryl with the Addition of Picric Acid at 150°	T 153
DTA Curve and Pyrolysis Curve for Tetryl	T 155
Detonation vs Charge Diameter Curves for Coarse Tetryl	T 156
Steady-State Detonation Velocity of Tetryl as a Function of Charge Diameter	T 156
Impact Velocity Required for Detonation	T 161
Cross Section of DDT Tube	T 162
Effect of Compaction on Predetonation Column Length of Tetryl	T 162
Heat Production and Heat Loss Rates	T 173
Experiment to Illustrate the Critical Nature of a Thermal Explosion	T 174
Heating Curves (Temperatures vs Time)	T 174
Temperature Profiles for Times Near the End of the Induction Period	T 178
Explosion Times for RDX in Various Geometries	T 179
Graphs for Spheres, Cylinders, and Slabs	T 180
Temperature Distribution During Cooling of a Spherical Element of Inert Material	T 181
The Relative Error of Calculation	T 184
Hugoniot Curve, Rayleigh Line and Isentropes	T 210
Nomenclature on the Hugoniot Curve for Detonation and Deflagrations	T 210
Family of Hugoniot Curves for Steady Detonation Wave	T 216
Initial TBI Configuration for Saturn V Launch Vehicle	T 225
TNT Nitration and Purification Equipment Arrangement	T 237
TNT Nitrator System	T 238
Nitrator with Dynamic Separator	T 239
Dynamic Separator	T 240
TNT Purification Flow Scheme	T 245
Effect of pH on Heat Loss	T 245
Effect of pH on By-Product Formation	T 245
Differential Thermal Analysis – TNT	T 254
Temperature Change During the Nitration of p-Nitrotoluene	T 310
Pattern of Detonation vs Density Curves for 2,4-DNT	T 311
Elements of the Artillery Trajectory	T 346
Impact Sensitivity of Polynitroaromatics as Function of OB_{100}	T 378
Thermogram of Tungsten Ignition in Oxygen	T 404
Temperature Profile for Tungsten-Potassium Dichromate	T 408
DTA Curve for Tungsten-Potassium Dichromate	T 408
Exothermicity of the Ignition Reaction of the Tungsten-Potassium Dichromate System	T 409

**SUPPLEMENT TO THE
LIST OF ABBREVIATIONS FOR BOOKS AND PERIODICALS
GIVEN IN VOL 1, pp Abbr 66 to Abbr 76; VOL 2, pp XI to XII; VOL 3, pp XII to XIII;
VOL 4, pp XLVII to L; VOL 5, p XIII; VOL 7, p X; and VOL 8, p XIV**

- | | |
|---|---|
| Bretherick (1979) | L. Bretherick, "Handbook of Reactive Chemical Hazards", 2nd Ed, Butterworths, London (1979) |
| Meyer (1977) | R. Meyer, "Explosives", Engl Ed, Verlag Chemie, NY (1977) |
| Sax (1979) | N. Irving Sax, "Dangerous Properties of Industrial Materials", 5th Ed, Van Nostrand Reinhold, NY (1979) |
| Blasters' Hndbk (1977) | Anon, "Blasters' Handbook", Technical Service Section, Explosives Products Division, E.I. duPont de Nemours & Co, Wilmington, Delaware (1977) |
| JHazardousMat
(Vol, No, Year & Page) | Journal of Hazardous Materials, Elsevier Scientific Publishing Co, Amsterdam (Vol 1, No 1 published 1977) |
-

**SUPPLEMENT TO THE
LIST OF BOOKS ON EXPLOSIVES, PROPELLANTS, PYROTECHNICS AND ORDNANCE ITEMS
GIVEN IN VOL 1, p A676; VOL 2, pp C215 to C216; VOL 3, pp XIV to XV; VOL 4, pp LI to LV;
VOL 5, pp XIV to XV; VOL 6, p X; VOL 7, pp XI to XII; and VOL 8, p XV**

- H.E. Malone, "The Analysis of Rocket Propellants", Academic Press, NY (1976)
- C.F. Foss, "Artillery of the World", Revised Ed, Charles Scribner's Sons, NY (1976)
- E.R. Plunkett, "Handbook of Industrial Toxicology", Chemical Publishing Co, NY (1976)
- M.J.H. Taylor & J.W.R. Taylor, "Missiles of the World", Charles Scribner's Sons, NY (1976)
- Anon, "Recoilless Rifle Weapon Systems", **AMCP 706-238**, Engineering Design Handbook, US Army Materiel Command, 5001 Eisenhower Ave, Alexandria, Va 22333 (1976)
- Anon, "Reliable Military Electronics", **AMCP 706-124**, Ibid (1976)
- Anon, "Environmental Series, Part Three, Induced Environmental Factors", **AMCP 706-117**, Ibid (1976)
- C.E. Gregory, "Explosives for Australasian Engineers", 3rd Ed, University of Queensland Press, Australia (1977)
- E.C. Ezell, "Small Arms of the World", 11th Ed, Stackpole Books, Harrisburg, Pa (1977)
- C. Saint-Arroman, "Pratique Des Explosifs", Editions Eyrolles, Paris (1977)
- Anon, "Blasters' Handbook", E.I. duPont de Nemours and Co, Wilmington, Delaware (1977)
- R. Meyer, "Explosives", Engl Ed, Verlag Chemie, NY (1977)
- I.V. Hogg & J. Weeks, "Military Small Arms of the 20th Century", Hippocrene Books, NY (1977)
- R. Germershausen et al, "Waffentechnisches Taschenbuch", Rheinmetall GmbH, Dusseldorf (1977)
- S.L. Herman, "Explosives Data Guide", Explosives Research Institute, Inc, PO Box 2103, Scottsdale, Arizona (1977)
- H. Neunhoeffler & P.F. Wiley, "Chemistry of 1,2,3-Triazines and 1,2,4-Triazines, Tetrazines, and Pentazines", John Wiley & Sons, NY (1978)
- E.E. Hackman III, "Toxic Organic Chemicals—Destruction and Waste Treatment", Noyes Data Corp, Park Ridge, NJ (1978)
- Anon, "Fire Protection Guide on Hazardous Materials", 7th Ed, National Fire Protection Association, Boston, Mass (1978)
- I.V. Hogg, "British and American Artillery of World War 2", Hippocrene Books, NY (1978)
- M. Lumsden, "Anti-personnel Weapons", Stockholm International Peace Research Institute, Crane, Russak & Co, NY (1978)
-

XIV

- B. Earl, "Cornish Explosives", The Trevithick Society, Trevinon House, Cornwall, England (1978)
- C.E. Gregory, "Explosives for North American Engineers", 2nd Ed, Trans Tech Publications, Rockport, Mass (1979)
- M. Summerfield & H. Krier, Eds, "Interior Ballistics of Guns", American Institute of Aeronautics & Astronautics, NY (1979)
- R.A. Scott, Jr, Ed, "Toxic Chemical and Explosives Facilities – Safety and Engineering Design", American Chemical Society, Washington, DC (1979)
- M. Sittig, "Hazardous and Toxic Effects of Industrial Chemicals", Noyes Data Corp, Park Ridge, NJ (1979)
- C.L. Mader, "Numerical Modeling of Detonations", Univ of California Press, Berkeley, Calif (1979)
- W. Fickett & W.C. Davis, "Detonation", Univ of California Press, Berkeley, Calif (1979)
- N. Irving Sax, "Dangerous Properties of Industrial Materials", 5th Ed, Van Nostrand Reinhold Co, NY (1979)
- K. Gugan, "Unconfined Vapor Cloud Explosions", Gulf Publishing Co, Houston, Texas (1979)
- J. Weeks, Ed, "Jane's Infantry Weapons, 1979–80", 5th Ed, Franklin Watts, NY (1979)
- R.T. Pretty, Ed, "Jane's Weapon Systems, 1979–80", 10th Ed, Franklin Watts, NY (1979)
- C.F. Foss, Ed, "Jane's Armour and Artillery, 1979–80", 1st Ed, Franklin Watts, NY (1979)
- L. Bretherick, "Handbook of Reactive Chemical Hazards", 2nd Ed, Butterworths, Boston (1979)
- J. Owens, Ed, "Brassey's Infantry Weapons of the World–1979", 2nd Ed, Crane, Russak & Co, NY (1979)
- J.M. Shevitz, "The Weaponsmakers", Schenkman Publishing Co, Cambridge, Mass (1979)
- R.C. Quertermous & S.C. Quertermous, "Modern Guns, Identification and Values", Crown Publishers, NY (1979)
- V. Lindner, "Explosives and Propellants", in Kirk-Othmer, "Encyclopedia of Chemical Technology", Vol 9, 3rd Ed, 561–671, John Wiley & Sons, NY (1980)
- T. Gander & P. Chamberlain, "Weapons of the Third Reich", Doubleday & Co, Garden City, NY (1980)
- J.H. McLain, "Pyrotechnics and Applications of Solid State Chemistry", Franklin Institute Press, Franklin Research Center, Philadelphia, Pa (1980)
- Anon, "Unconventional Warfare Devices and Techniques", Pyro Press Publications, Box 12010, Lexington, Ky (1980)
- B. Fitzsimons, Ed, "Illustrated Encyclopedia of 20th Century Weapons and Warfare", 24 Vols, Purnell Reference Books, Milwaukee, Wis (1980)
- Anon, "International Weapon Developments", 3rd Ed, Presidio Press, San Rafael, Calif (1980)
- L.H. Yaverbaum, "Technology of Metal Powders", Noyes Data Corporation, Park Ridge, NJ (1980)
-

Q

ENCYCLOPEDIA OF EXPLOSIVES and RELATED ITEMS

Volume 9

QDX (SEX). Code letters for Octahydro-1-acetyl-3,5,7-trinitro-s-tetrazine. See under 1-Aceto-3,5,7-trinitro-1,3,5,7-tetrazacyclooctane in Vol 1, A49-R

Quadrant, Fire Control. A mechanical device having scales graduated in mils, with a fine micrometer adjustment(s) and a leveling and/or a cross-leveling dial(s). It may be physically attached to the gun, gun mount, or gun carriage and is used for setting and/or measuring the elevation angles of a weapon for obtaining the horizontal range of a target. When attached to the elevating mechanism as a part thereof, it is called *elevation quadrant* if graduated in mils or degrees, or *range quadrant* if graduated in range units. When it consists of a separate unattached instrument for hand placement on a reference surface, it is called a *gunner's quadrant*
Ref: Anon, OrdnTechTerm (1962), 241

Quail. An air-launched decoy missile carried internally in the B-52 *Stratofortress* strategic bomber, and used to degrade the effectiveness of enemy radar, interceptor aircraft, air-defense missiles, etc. It is a miniature turbojet-powered aircraft which flies at the same speed as the B-52 and is equipped with electronic countermeasure (ECM) gear which simulates the B-52's radar "signature". Designated as **ADM-20**, it has a length of 12.9 ft, a diameter of 2.5 ft, a 5 ft 5 inch wing span (once it has been dropped from the bomber's weapon bay and its wings have unfolded), a launching wt of 1230 lbs, and a range of 345 miles. Unlike the active ECM devices carried by the B-52, Quail is intended to degrade hostile radar by dilution, rather than by deception. Its range — which determines how long the dilution can be maintained — is not known

Refs: 1) E. Luttwak, "A Dictionary of Modern War", Harper & Row, NY (1971), 158 2) J. Quick, "Dictionary of Weapons and Military Terms", McGraw-Hill, NY (1973), 361

Quaker Guns. Dummy pieces of ordn made to resemble real artillery and used to deceive an enemy

Ref: J. Quick, "Dictionary of Weapons and Military Terms", McGraw-Hill, NY (1973), 361

Qualified Product. A product which has been examined and tested and which has passed all qualification requirements of the applicable specification

Qualified Products List (QPL). A list of products, qualified under the requirements stated in the applicable specification, including appropriate identification and reference data with the name and plant address of the manufacturer
Ref: Anon, OrdnTechTerm (1962), 241

Qualitative Development Requirements Information (QDRI). Information concerning items of Ordnance which will require future development. This information is furnished by class II Ordnance installations having a research and development mission to civilian organizations properly qualified by Ordnance Districts

Qualitative Materiel Development Objective (QMDO). A Department of the Army approved statement of a military need for development of new materiel, the feasibility of which cannot be determined sufficiently to establish a *qualitative materiel requirement*

Qualitative Materiel Requirement (QMR). A Department of the Army approved statement of a military need for a new item, system, or assemblage, the development of which is believed to be feasible. QMR's serve as a basis for the development of *military characteristics*, and provide guidance for research and development programming actions

Ref: Anon, OrdnTechTerm (1962), 241

Quantity-Distance (Explosives Safety Distance). The prescribed minimum distance between various classes and quantities (net weight) of expls,

and between such expls and specific exposures (inhabited bldgs, public highways, public rail-ways, petroleum, aircraft, etc), affording an acceptable degree of protection

See also under "American Table of Distances for Storage of Explosives" in Vol 1, A168-L, and "Effects of Explosions and Table of Dis-tances for Storage of Explosives" in Vol 5, E11-L

For detailed in-depth information on this subject, consult the refs

Refs: 1) Anon, "Ammunition and Explosives Standards", **TM 9-1300-206** (1973), Chapt 5, pp 5-1 to 5-31 (Quantity-Distance Regulations, Classes and Tables) 2) C.E. Gregory, "Explo-sives for North American Engineers", Trans Tech Publications, Cleveland (1973), 252-56 3) Anon, "Ammunition and Explosives Safety Standards", **AR 385-64** (1975)

Quarrycord. A commercial cord type burning igniter designed mainly for lighting safety fuses for firing a large number of expl charges in secondary blasting operations. In appearance it resembles a colored twine, is soft and pliable but somewhat fragile. It can be lighted readily with a match and burns with an open flame at a speed of about one ft per sec, but is also sub-ject to ignition by open flame, sparks, friction, or a sharp blow. The principal advantages of *Quarrycord* are increased safety and convenience in lighting a great many fuses within a limited time, however, it is not used for sequential or rotation firing. It will not withstand w, and should not be strung until time for the blast
Refs: 1) Ellern (1968), 207 2) Blasters' Hndbk (1969), 103 & 133

Quaternary Ammonium Salts. See under Am-monium Salts, Quaternary in Vol 1, A381-L

Quebrachitol (Quebrachite, Methoxy pinite, *l*-Inositol methyl ether, Bornesitol).
 $C_6H_6(OH)_5.OCH_3$, mw 194.18, mp 190-94°, bp 210° at 6 mm, crystallizes well from acet. Was first obtained by Tanret (Ref 2) from quebrache by a series of operations, also de-scribed in Beilstein (Ref 1, p 1193). A. DeJong

(Ref 3) obtained quebrachitol by treating the latex of "Hevea brasiliensis" with alc and evapg the alc soln. V sl sol in w; somewhat sol in boiling alc; insol in eth; sol in concd sulfuric acid. On nitration, it yields an expl:

Quebrachitol Pentanitrate (Nitroquebrachite). $C_6H_6(ONO_2)_5.OCH_3$, mw 419.18, N 16.71%, OB to CO_2 -9.5%, bp (flashes on heating). Transparent, odorless, very viscous oil. Crater (Ref 5) prepd it by nitrating quebrachitol with mixed nitric-sulfuric acid, using the same tech-nique as in the prepn of NG. After nitration was complete, the mixt was run into a separator, where Quebrachitol Pentanitrate sepd out in an oily layer which was skimmed off and drowned in cold w. The sticky syrup was dissolved in eth and neutralized by emulsifying with Na carbonate soln. The two solns were sepd by means of a separatory funnel, and the eth evapg off under vac

Quebrachitol Pentanitrate is nearly insol in w, difficultly in concd sulfuric acid and v sol in eth, methanol, ethanol and gl acet ac. It flashes without exploding when dropped on a hotplate, and detonates when struck with a hammer on a steel plate, or with a No 6 blasting cap

According to Crater, its impact sensitivity with a 2 kg falling wt is positive at 4 cm and negative at 3 cm, which is nearly the same as for NG [see Naoúm, NG (1928), 141]. Later tests by Burke and McGill (Ref 6), as well as those of the duPont Co, showed that it is about 50% less sensitive to impact than NG, while its thermal stability is comparable to that of NG

Quebrachitol Pentanitrate was proposed by Crater (Ref 5) and Burke and McGill (Ref 6) as an ingredient of expl and proplnt compns. Crater prepd an expl for use in low-freezing Dynamites by nitrating a mixt of glycerin (or glycol), 50 to 95%, and quebrachitol, 50 to 5%. These mixts have higher viscosities than straight NG, but lower viscosities than NG plus nitrated sucrose. The mixt preferred by Crater of 80% glycerin and 20% quebrachitol, gave, on nitra-tion by the same method as used for the nitra-tion of glycerin, a product with pH 7 and a KI stability at 82.2° of 8 minutes. An example of a low-freezing Dynamite proposed by Crater is: a nitrated mixt of 80/20 NG and Quebrachitol Pentanitrate, 40; Na nitrate 46; pulp (woodmeal) 9; sawdust 4; and chalk 1%

Burke and McGill (Ref 6) also prepd Quercitol Pentanitrate as well as its mixts with nitrated polyhydric alcs, such as NG and nitroglycols. They proposed such mixts as proplnt ingredients

Refs: 1) Beil **6**, 1193, (587) & [1157] 2) C. Tanret, CR **109**, 908–10 (1889) & JCS **58** (I), 226 (1889) 3) A. deJong, Rec **25**, 48 (1906) & JCS **90** (II), 248 (1906) 4) G.S. Whitby, J. Dolid & F.H. Yerston, JCS **1926**, 1451–2 5) W. deC. Crater, USP 1850224 (1932) & CA **26**, 2867 (1932) 6) C.E. Burke & R. McGill, CanadP 326147 (1932) & CA **26**, 6140 (1932) 7) Blatt, OSRD **2014** (1944) 8) Hackh's (1972), 562-R

Queen Gray Recorder. An app for measuring the detonation velocity of expls, identical in principle to the Mettegang recorder (see in Vol **8**, M122-L). A model was installed and used at PicArns; see the ref for its description

Ref: I.A. Luke, ArmyOrdn **7**, 368 (1926)

d-Quercitol (2-Deoxy-D-chiro-inositol, D-1-deoxymuco-inositol, Acorn Sugar, 1,2,3,4,5-Cyclohexanepentol).

$\text{CHOH}(\text{CHOH})_2\text{CH}_2(\text{CHOH})_2$; mw 164.16; monoclinic crysts with a sweet taste; mp 234–35°; sol in w; sl sol in hot, almost insol in cold alc; practically insol in eth. Found in the acorns of various species of Quercus Fagaceae (Refs 2, 3 & 6). Its structure was detd by Kiliani (Ref 7), Posternak (Ref 8), and others (Ref 1, p [1151]). On nitration, it forms an expl compd: **Quercitol Pentanitrate** (Nitroquercite). $\text{C}_6\text{H}_7(\text{ONO}_2)_5$, mw 389.16, N 18.00%, OB to CO_2 –2.1%; nearly colorl, transparent, resinous substance; mp, explds

It was first prepd in 1851 by Dessaignes (Ref 3) by the nitration of quercitol with mixed nitric-sulfuric acids, and was recognized as “detonierende nitroverbindung”, but was not analyzed. The same compd was prepd by Homann (Ref 4), who used Strecker's method for the prepn of Nitromannitol, namely:

One part of finely pulverized quercitol was slowly added to a mixt of 4p nitric and 10p concd sulfuric acids, which was constantly stirred by hand. After the addition was com-

plete, the nitrating vessel was tightly closed and left standing for several days, with occasional stirring. The mixt was then poured into a large quantity of cold w. The resulting flakes were washed with w, dissolved in the smallest quantity of alc possible, and then reprecipitated by adding w. This operation could be repeated several times. The product was then dried. A N content as high as 17.8% was found vs 18.0% theoretical

Quercitol Pentanitrate is insol in w and easily sol in abs alc (especially when hot) and eth. When the dry material was heated on a Pt foil, an expln took place without leaving any residue

Refs: 1) Beil **6**, 1186 & 1188, (584) & [1151] 2) J. Braconnot, AnnChim **27**, [3], 392 (1849) 3) J. Dessaignes, CR **33**, 308 (1851) & Ann **81**, 105 (1852) 4) F.W. Homann, Ann **190**, 282 & 288 (1878) 5) F. Stohmann & H. Langbein, JPraktChem **45**, 336–37 (1892) 6) H. Müller, JCS **91**, 1766–67 (1907) 7) H. Kiliani, Ber **64**, 2473 (1931) 8) J. Posternak, Helv **19**, 1007 (1936) 9) A. Pérez Ara (1945), 309 10) CondChemDict (1971), 747-L 11) Hackh's (1972), 562-R 12) Merck (1976), No 7823

Quickmatch. See under Match in Vol **8**, M40-R

Quickmix. A production system, developed by Rocketdyne, for the manuf of composite proplnt. The solid ingredients, such as oxidizer and fuel additives, are placed in a dilute slurry with a low viscosity, volatile and immiscible carrier. These slurries, a minimum of two, and the fluid polymer and curing agent streams are metered to a continuous fluid mixer. The effluent from the mixer then flows to a separator and vacuum casting site where the carrier must be removed from the diluted proplnt

This process has the advantage that the materials are at all times handled in highly dilute solns, and that the mixer which uses a jet impingement principle has no moving parts. It has the disadvantage that the ingredients processed must in all cases be completely immiscible in the carrier, and it must also be possible to have a

carrier with a high enough vapor pressure to be separated totally from the proplnt at the casting site by flash evaporation or other vacuumizing techniques

The Quickmix process is also applicable to such mixts as colored smokes (Ref 4)

Refs: 1) F.B. Cramer, USP 3022149 (1962)
 2) R.D. Sheeline, AIChE Natl Meeting, Las Vegas, Nev (Sept 1964) 3) Ibid, ChemEng-
 Progr **61**, 77-82 (1965) 4) Ellern (1968),
 413 5) G.A. Fluke, "Composite Solid Propellant Processing Techniques", in "Propellants Manufacture, Hazards, and Testing", Advances in Chemistry Series 88, ACS, Washington (1969), 184-85

Quickness (Vivacity, Vivacité des Poudres).

A property which is proportional to the mass rate of burning of a gun proplnt of a given geometrical form and burning at a given pressure. See under "Coefficient de Vivacité des Poudres" in Vol 3, C390-R

Quickness, Relative (RQ). The practice in the USA in designing a proplnt charge for a new gun or in designing a new proplnt charge for an existing gun is to select a proplnt compn on the basis of its force and flame temp, and establish the optimum granulation empirically. Having established a given lot of proplnt as the standard, additional lots that are manufd must match the standard by actual comparison firing in the gun. For quality control purposes, firing in a closed bomb (see Vol 3, C334) can yield a relative quickness, *RQ*. In this determination the bomb is instrumented to record directly dP/dt vs pressure (Fig 1). The test proplnt is fired in comparison with the standard proplnt, and *RQ* is detd as the ratio of dP/dt for the test proplnt to dP/dt for the standard at one or more pressure levels
 Ref: A.M. Ball, "Explosives Series—Solid Propellants, Part I", **AMCP 706-175** (1964), 20-21

Quinalino-diazido-copper. See under "Copper (II) quinoline Azide" in Vol 3, C518-L
 Addnl Ref: A. Cirulis & M. Straumanis, JPrakt-Chem **162**, 307-28 (1943) & **CA 38**, 1970 (1944)

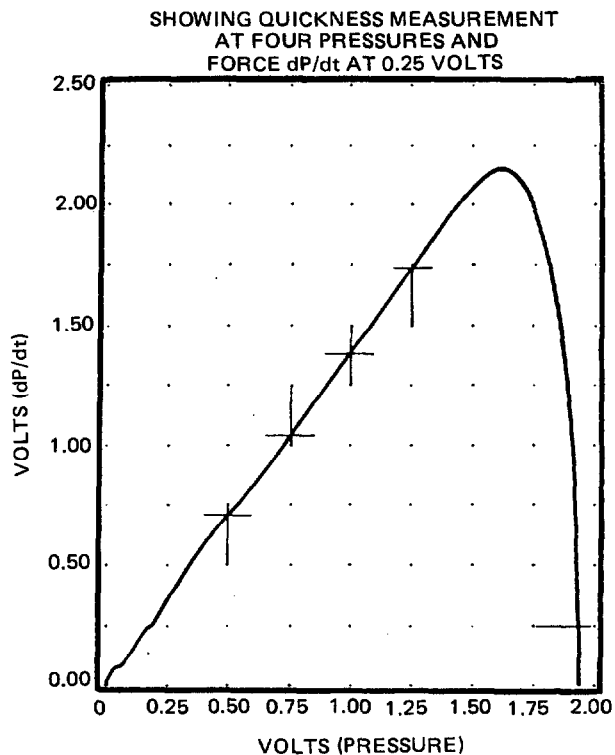

Fig 1 Closed Bomb Record

Quinan, William Russell (1848-1910). An American artillery officer, a graduate of West Point in 1870, who resigned his commission in 1880 and devoted himself to the development and manufacture of industrial expls. He was supervising manager of the California Vigorite Powder Works from 1880 to 1883, and superintendent of the Hercules plant of the California Powder Works from 1883 to 1889, at which time he resigned to accept a flattering offer from Cecil Rhodes to build and manage a large explosives works in South Africa (Cape Explosives Works Ltd)

Among his most important inventions relating to expls were the Crusher Gage (see Vol 3, C564-L) for testing high expls, the Quinan Packing Machine (the first successful machine for loading Dynamite into cartridges), improvements in the manuf of sulfuric acid, and numerous expl compns. His book, "High Explosives", was published in 1912 by Critchley Parker, Melbourne, Australia

Refs: 1) T.J. Wrampelmeier, introduction to W.R. Quinan, "High Explosives", Critchley Parker, Melbourne (1912) 2) VanGelder & Schlatter (1927), 506-7

Quinidino-tetrazido-copper. See under "Copper (II) quinidine Azide" in Vol 3, C518-L

Addnl Ref: A. Cirulis & M. Straumanis, JPrakt-Chem 162, 322 (1943) & CA 38, 1970 (1944)

Quinino-tetrazido-copper. See under "Copper (II) quinine Azide" in Vol 3, C518-L

Addnl Ref: A. Cirulis & M. Straumanis, JPrakt-Chem 162, 322 (1943) & CA 38, 1970 (1944)

Quinol and Derivatives. See under "Hydroquinone and Derivatives" in Vol 7, H227-R to H228-R

Quinoline (Lencoline, Chinoleine, 1-Benzazine, Benzo(b)pyridine). C_9H_7N , mw 129.15, hydr liq, bp 237.7° , mp -15° , d 1.0900g/cc at $25/4^\circ$, RI 1.62683 at 20° . Difficultly sol in cold w, more easily in hot w; misc with alc, eth, CS_2 ; dissolves S, P and

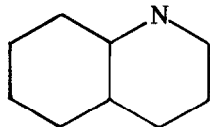

As_2O_3 . Occurs in small amts in coal tar. Prepd by the Skraup synthesis by heating aniline with glycerol and nitrobenzene in the presence of sulfuric acid (Refs 1 & 4)

Quinoline is combustible and a fire risk, and is highly toxic by swallowing and inhalation (Ref 3)

The traditional unpredictably violent nature of the Skraug reaction has been attributed to a lack of stirring and adequate temp control, as reported in many published descriptions (Ref 2). An MCA case history (Ref 5) reports on a large-scale (450 liter) reaction, in which sulfuric acid was added to a stirred mixt of aniline, glycerol, nitrobenzene, ferrous sulfate and w, which went out of control soon after the addition. A 150mm rupture disc blew out first, followed by the man-hole cover of the vessel. The violent reaction was attributed to doubling the scale of the reaction, an unusually high ambient temp (reaction con-

tents at 32°), and the accidental addition of excess sulfuric acid. Expt showed that a critical temp of 120° was reached immediately on addition of excess acid under these conditions

Refs: 1) Beil 20, 339, (134) & [222] 2) A. Blumann, ProcRAustChemInst 31, 286 (1964) 3) Anon, "Toxic and Hazardous Industrial Chemicals Safety Manual", The International Technical Information Institute, Tokyo (1975), 454 4) Merck (1976), 1050 (No 7888) 5) Anon, "Case Histories of Accidents in the Chemical Industry", No 1008, Manufg Chemists' Assoc, Inc, Washington, DC (no date)

Quinoline Salts and Addition Compounds.

Chlorate. $C_9H_7N.HClO_3$, yel crystals, mp $66-67^\circ$; very hygroscopic; sol in alc & w; detonates on contact with a flame or with concd sulfuric acid (Ref 1, (136) & Ref 7)

Perchlorate. $C_9H_7N.HClO_4$. Although not found in Beilstein, there is no doubt that it can be prepd, and that it would be expl (see *Note*)

Note: Ethylquinolinium perchlorate and Propylquinolinium perchlorate were prepd by Datta and Chatterjee (Ref 8) and found to be expl. The former expld at 330° , the latter at 342°

Perchromates.

$2C_9H_7N+H_2Cr_2O_7$; yel needles from w; mp $164-67^\circ$. It was prepd in 1856 by C. Williams (Ref 2), and later by others (Refs 3 & 4). Sl sol in w (1p in 282p H_2O at 10.5°). Explds on rapid heating (Ref 1, p 345)

$C_9H_7N+HCrO_5$; blue plates; mp, explds on heating with a bright flash. Sol in eth, benz and CS_2 ; insol in w, alc & ligroin. Was prepd by Wiede (Ref 5), and is an unstable compd (Ref 1, p 345)

Rüst & Ebert (Ref 9) report that heating a mixt of quinoline & perchromate can produce an expln

Picrate. $C_9H_7N.C_6H_3O_7N_3$; pale-yel needles from benz; was prepd in 1881 by Goldschmiedt & Schmidt [Monatsh 2, 18 (1881)]. Other investigators used this salt as a standard for detg the purity of quinoline (Refs 3 & 6). Its solubility, as detd by H. Decker [Ber 36, 2571 (1903)], is diff sol in w, sl sol in alc (0.25p in 100p of cold and 1.18p in boiling alc); v sl sol in eth (0.037p in either hot or cold). It explds on rapid heating [also see Ref 1, pp 349 & (137)]
Refs: 1) Beil 20, 345 & 349, (136 & 137)

2) C. Williams, *JahresberCTR* **1856**, 534 3) S. Hoogenswerff & W.A. vanDorp, *Rec* **1**, 13-14 (1883) 4) E. Lellmann & H. Alt, *Ann* **237**, 323 (1887) 5) O.F. Wiede, *Ber* **31**, 3142 (1898) 6) B. Vanzetti & V. Gazzabin, *Atti-AccadLinceiMem* [5] **24**, II, 531 (1915); *Gazz* **46**, I, 149 (1916); *JCS* **110**, II, 175 (1916) 7) R.L. Datta & J.K. Choudhury, *JACS* **38**, 1084 (1916) 8) *Ibid*, *JCS* **115**, 1009 (1919) 9) E. Rüst & A. Ebert, "Unfälle Beim Chemischen Arbeiten", Rascher Verlag, Zurich (1948), 297

Quinone and Derivatives. See under Benzoquinone and Derivatives in Vol 2, B79-R ff

Quinone, Azido and Azido Halogen Derivatives of. See under Azido and Azido Halogen Derivatives of Benzoquinone in Vol 2, B80

Quinone Diazides. E. von Herz (Ref 1) proposed the use of nitrated quinone diazides and tetrazides of polyhydric phenols or their metallic salts in percussion caps and primers, either as a top charge over a main charge (Tetryl, PETN or TNT), or in mixts with usual primary expls such as LA, MF, etc. Typical compds were 4,6-dinitro-2-quinone diazide, the K salt of dinitro-3-hydroxyquinone diazide, metallic salts of dinitro-4-hydroxyquinone diazide, the Pb salt of dinitro-3,5-dihydroxyquinone diazide, and sym-tetra-nitrodihydroxydiphenylolquinone tetrazide

J.E. Burns (Ref 2) proposed the use of nitrated quinone diazides, such as the 2,6-dinitro-2-diazide, with Pb picrate, Na nitrate, Pb thio-

cyanate, glass, and gum arabic in priming mixts
Refs: 1) E. von Herz, *GerP* 373426 (1919); *Ibid*, *JSCI* **42**, 865A (1923); *Ibid* *BritP* 207563 (1923) & *CA* **18**, 1573 (1924) 2) J.E. Burns, *USP* 1878621 (1932) & *CA* **27**, 420 (1933)

Quinone, Nitro and Other Derivatives of. See under Nitro and Other Derivatives of Benzoquinone in Vol 2, B80-R to B81-L

Quinone, Substituted Diazonium Derivatives of. See under Substituted Diazonium Derivatives of Benzoquinone in Vol 2, B81-L to B83-L

Quinonediiimine and Derivatives. See under Benzoquinonediiimine and Derivatives in Vol 2, B83-L to B83-R

Quinonedioxime and Derivatives. See under Benzoquinonedioxime and Derivatives in Vol 2, B83-R to B84-L

Quinonedioxime Peroxide. See under Benzo-furoxan in Vol 2, B68-L

Quinoneimine and Derivatives. See under Benzoquinoneimine and Derivatives in Vol 2, B84-L

Quinonemonoxime and Derivatives. See under Benzoquinonemonoxime and Derivatives in Vol 2, B85-L to B86-R

R



Rabinet (Robinet). A small, obsolete piece of ordnance that weighed 300 lbs and fired a ball about 1-3/8" in diam

Ref: J. Quick, "Dictionary of Weapons and Military Terms", McGraw-Hill, NY (1973), 363

Rabut Explosives. Blasting expls suitable for mines and quarries: 1) Na chlorate 77.1, DNT 17.1, castor oil 5.05 & paraffin 0.75%; 2) K chlorate 75, DNT 18.4, MNN 1.06, castor oil 4.8 & paraffin 0.74%

Ref: L. Rabut, FrP 696911 (1930) & CA 25, 2853 (1931)

Rack-a-rock. A Sprengel type expl (see Vol 2, C202-R), patented by S.R. Devine in 1881, was used for blasting out Hell Gate Channel at the entrance of New York Harbor. On October 10, 1885, 230399 lbs of Rack-a-rock, along with 42331 lbs of Dynamite, was expld for that purpose in a single blast. Its constituents, K chlorate (75-80%) and Nitrobenzene (15-20%), were transported separately to the work site and treated in the following manner: the chlorate was placed in cotton bags; these were suspended in wire cages from a spring balance and dipped into a bucket contg NB until the desired wt of NB was absorbed. The loaded cotton bags were then sealed in water-tight Cu cartridges

The max effect for underwater explns was obtained with 79% K chlorate and 21% NB. This effect was equal to about 108% of Dynamite No 1 (NG 75, kieselguhr 25%). The charge was

usually fired with a primer consisting of BlkPdr (10% by wt of cartridge) wrapped in w-impermeable paper

The same expl was prepd with nitronaphthalene, which was less expensive than NB. A subsequent *Rack-a-rock Special* expl formulation consisted of Rack-a-rock in which the NB was wholly or partially replaced by "dead oil" (a mixt of coal-tar hydrocarbons), and to this was added from 12 to 16% PA

Refs: 1) Marshall 1 (1917), 379 2) Ramsey & Weston, Expls (1917), 23 3) Colver (1918), 135 4) Davis (1943), 354 5) Thorpe 4 (1946), 545

Raczyński Process. A continuous process for manufg NG, invented by Raczyński in 1935 (Ref 1), the distinctive feature of which is exact metering of mixed acid and glycerine by means of automatic mechanical devices (also see under Continuous Methods for Manufacturing Explosives in Vol 3, C501-L to C504-R)

The nitrating acid is metered by means of tipping a vessel fixed on a horizontal shaft (Fig 1a). Acid flows into the vessel (1) from a pipe ending inside a container constructed of acid-resistant steel or lead, in which the tipping vessel is located. The stream of acid fills the vessel, and as a determined weight is reached it tips over and another empty vessel swings into place under the acid inlet pipe. This fills in turn and tips over to pour off its contents, and so the cycle continues. A volume-meter connected to the equipment indicates the volume of liquid

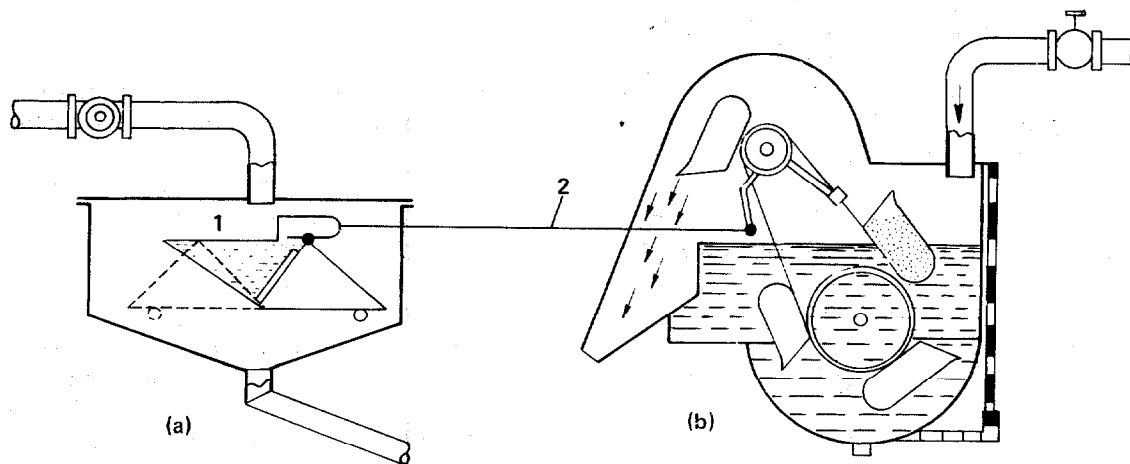

Fig 1 Apparatus for Continuous Dosage of Acid (a) and Glycerine (b) According to Raczyński

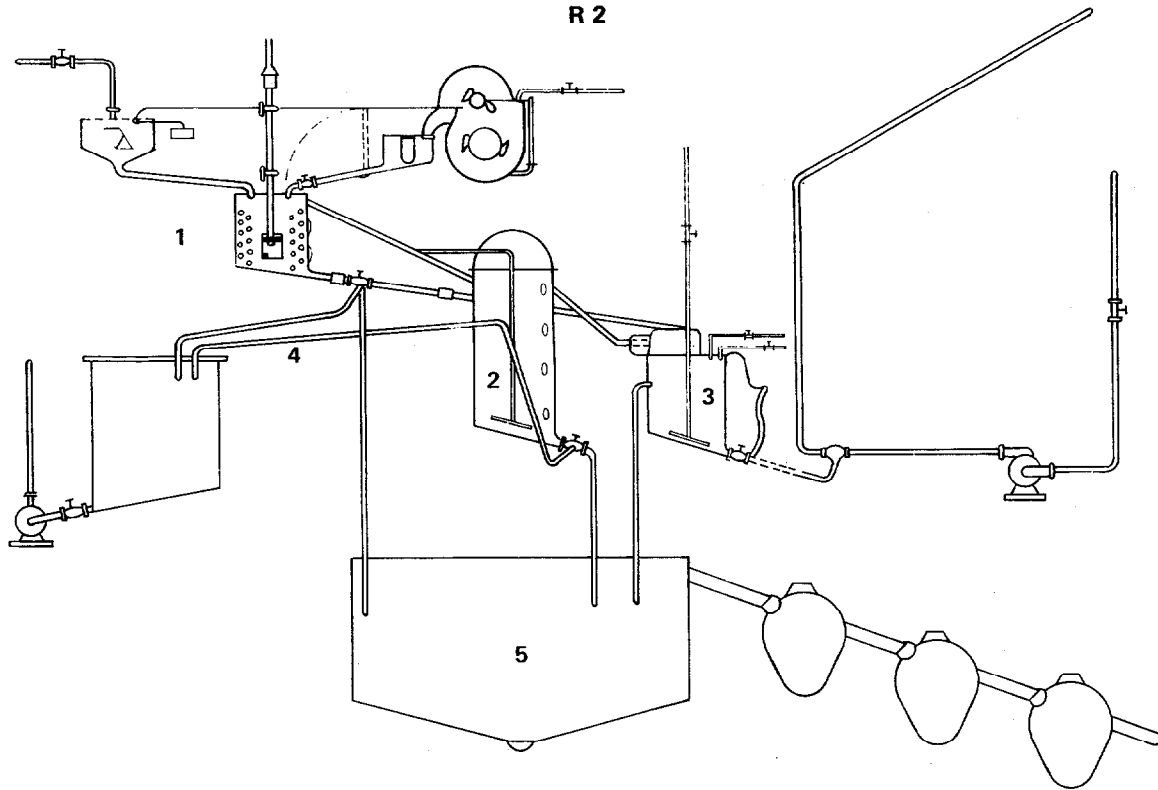

Fig 2 Flow-Sheet of Continuous Method of Manufacture of Nitroglycerine According to Raczyński

measured out. Acid from this device passes into the nitrator

Glycerin is metered by means of a bucket conveyor (Fig 1b) driven by hydraulic turbine

The arrangements for introducing measured quantities of acid and glycerin are connected by a lever (2) in such a way that the influx of acid and NG into the nitrator proceeds at a pre-determined ratio. Movement of the tipping vessel exerts a pull on the lever, and this takes the brakes off the bucket conveyor. The conveyor immediately starts to move, and continues to do so until the acid metering vessel returns the lever to its former position and stops the conveyor again

A diagram of a plant for NG manuf by the continuous Raczyński process, including the separating and washing units, is outlined in Fig 2

For nitration, a nitrator (1) equipped with cooling coils and a mechanical stirrer comprising a cylindrical rotor equipped internally with turbine paddles is used. At a sufficiently high rate of rotation, the liquid flows rapidly thru the rotor in one direction, thus ensuring correct circulation between the coils

The emulsion of NG and acid flows to a cylindrical separator (2) from which the upper

NG layer flows over the high level pipeline to a primary washing tank (3). The spent acid is removed from below by a hydraulic system (4). Should any danger of decompn arise, it is possible to empty the contents of the nitrator or separator into the drowning tank (5). As the separator is emptied, the compressed air inlet valve should be opened simultaneously to mix the NG with the acid again

Refs: 1) S. Raczyński, PolP 21648 (1935)
2) Urbański 2 (1965), 106-07

Radar. Radar (RADIO DETECTION AND RANGING) devices operate by transmitting a particular form of electromagnetic energy, and processing that portion of it (the "echo") which is radiated back. Radar techniques are used to detect and locate targets, to control weapons, for navigation, and in a secondary form - for aircraft identification

Radar techniques are based on the exploitation of three main properties of electromagnetic "waves": a) electromagnetic waves travel at the velocity of light so that the time interval between the transmission of a signal and its returning echo, divided by two and multiplied by the

speed of light, gives the range of the reflecting object; b) electromagnetic waves can be transmitted in beams of varied shape thru appropriate antennas, including pencil-point beams which can accurately locate and follow moving objects; and c) electromagnetic waves undergo a shift in frequency when they are reflected by an object moving relative to the radar equipment. This shift in frequency (the Doppler effect) is proportional to the relative speed of movement of the reflecting object, so that the speed can be calculated (Ref 1)

Radar devices in their most elementary form consist of an oscillator which produces electromagnetic radiation, a wave-guide that carries it to the antenna (which beams the "waves" and collects returning echoes), a receiver which selects and amplifies the echo, and a display or signal unit which makes the data available in the required form (Ref 1)

The following are radar-band types, frequencies, and typical applications: (1) *L-band* (1400 megahertz); used for early-warning systems; (2) *S-band* (3000 megahertz); used for search, fighter direction, and missile acquisition; (3) *X-band* (10,000 megahertz); used for gun laying, ground-to-air missile tracking, and ground-to-air missile guidance; (4) *KU band* (14,000 megahertz); used for airborne search, air-to-air missile tracking, air-to-air missile guidance, and blind bombing; (5) *KA-band* (35,000 megahertz); used for airport ground surveillance, mortar locating, and mapping and reconnaissance (Ref 2)

Search radars have large antennas and operate in low frequencies to scan the air-space perimeter and detect targets. Since the intensity of the returning echo is greatest when the receiving antenna is pointing directly at the reflecting object, the angle of elevation of the antenna and its bearing when the echo is strongest give the position of the detected object. But in order to determine the range of the target the transmitted signal must be "coded" or marked in some way so that the time interval for the round-trip can be determined precisely. There are two ways of doing this: (1) by transmitting the signal in short bursts or "pulses" and leaving a silent gap within which the returning echo is isolated. This is known as *pulsed radar*; and (2) by changing the frequency of the transmission at a known rate so that the echo is paired to the right signal by comparing the frequencies.

This is known as frequency modulation and is used on the second type of radar, *Continuous Wave* or CW radar (Ref 1)

Once the target's angle of elevation, bearing and range are known, the next step is to follow it, predict its path, and direct weapons against it. To do this, tracking or "narrow beam" radars are needed, which often operate at higher frequencies, since the higher the frequency the "straighter" the beam. These tracking radars produce a "pencil" beam which can rapidly scan the area of the detected target and, having "acquired" it, "lock" on to it. Apart from the elevation, bearing and range, the tracking radar can also produce target speed data by means of the Doppler effect. Information about the target is then passed on to a third item of electronic equipment, which unlike the search and tracking units is not a radar but a computer. This records and predicts the path of the target and produces instructions which are fed to the shooting part of the weapon system. If anti-aircraft guns are used, the tracking radar-programmer system actuates servo-controls which point and fire the guns; if surface-to-air missiles are used, both target and missile are tracked and the computer generates flight instructions which are sent to the missile in order to keep it on an interceptor course. In so-called "all-weather" fighter systems, the links are more complex. While the target is being tracked, the fighter is flown towards it on the basis of the data produced by the programmer, the aircraft's nose-cone AI (airborne-interception) radar then "locks" on to the target and keeps the fighter in line with it. When the target comes within the range of the aircraft's weapons, a signal is given to the pilot or else routed directly to the missiles or guns (Ref 1)

Many air-to-air and surface-to-air missiles use semi-active homing guidance, yet another form of radar weapon control. The missile is equipped with a radar receiver set which can collect, though not transmit, electromagnetic radiation. The target is "illuminated" by a ground or airborne radar, and the missile homes on to the echoes, which bounce off the target and are picked up by the missile's receiver. The echoes are then put thru a programmer which generates signals to the autopilot in order to keep the missile on an interception course (Ref 1)

Radar-bombing techniques have been in use since WWII. In their simplest form, the bomber

is tracked by friendly radars, and when it is over the target (a fixed point of known location) the free-fall bombs are released, thus achieving accuracy even at night and in bad weather; but current techniques are more complex and often rely on inertial guidance rather than radar for a "fix" (Ref 1)

The poor reflectivity of most ground features and their interference ("clutter") have limited the application of radar in the detection of ground targets, but a minimum of two types of battlefield radars have been developed: mortar-locating sets, which track a mortar shell so that its ballistic path can be used by a programmer to compute the location of the mortar (or howitzer) which fired it, and battlefield surveillance sets. These cannot pick out fixed targets with any precision, but they can identify movements at long ranges or in "blind" visibility by using the Doppler effect, and they can give the range of a target which has been identified, and towards which a narrow beam is pointed. All these applications rely on primary radar, ie, on the use of echoes bounced off a reflecting object; but IFF (Identification Friend or Foe) uses "secondary" radar. In this, an "interrogator transmitter" on the ground sends a signal which is picked up in the aircraft, and this automatically switches on a transmitter (transponder) which sends an answering signal in a code which is different for every aircraft, so that the ground controller can identify the aircraft. This IFF system is used, among other things, for air defense systems, when the ground controllers have to be able to discriminate between friendly interceptors and enemy bombers (Ref 1)

Proximity fuzes (VT), which produced spectacular improvements in the effectiveness of anti-aircraft (and other) artillery in WWII, are also radar devices. The VT fuze has a simple amplifier connected with the equally simple oscillating detector and antenna; when the output of the amplifier is of sufficient magnitude (ie, when the target comes within the "kill-radius" of the shell) the firing circuit (usually a thyratron) triggers the detonation (Ref 1)
Refs: 1) E. Luttwak, "A Dictionary of Modern War", Harper & Row, NY (1971), 159-62
 2) J. Quick, "Dictionary of Weapons and Military Terms", McGraw-Hill, NY (1973), 363
 3) EncyclBritannica **18** (1973), 993-1019

4) M.I. Skolnik, "Radar", in R.M. Besancon, Ed, "The Encyclopedia of Physics", Van Nostrand Reinhold, NY (1974), 761-62 5) R.T. Pretty & D.H.R. Archer, Eds, "Jane's Weapon Systems", 6th Ed, Franklin Watts, NY (1974), 551-615 (Ground Radar), 616-56 (Naval Radar), 657-78 (Airborne Radar)

Radial Band Pressure. The pressure which is excited on the rotating band by the walls of the gun tube, and hence against the projectile wall at the band seat, as a result of the engraving of the band by the gun rifling. Since the same pressure is exerted against the gun tube, it must be taken into account in gun design as well as in projectile design

Ref: Anon, OrdTechTerm (1962), 244

Radial Expansion. A method of making gun tubes by expanding steel cylinders under internal pressure until the interior diameter has been permanently enlarged. This method is also known as *cold working* and *auto-frettage* (Fr term meaning "self-hooping")

As generally practiced in the USA, a hollow steel cylinder (often consisting of a centrifugal casting) with an interior diameter slightly less than the caliber desired is subjected to an interior hydraulic pressure of sufficient intensity to enlarge the bore permanently about 6 percent. The outside diameter of the cylinder is enlarged only very slightly (about 1 percent). When the hydraulic pressure is released, the outer layers tend to shrink to their original dimensions and the inner layers tend to maintain their enlarged diameter, thus putting the critical inner layers under compression by the contracting force of outer layers. Final machining and rifling is, of course, still required. This method, like the "built-up" and "wire-wrapped" methods of gun construction, gives the gun a high resistance to internal (propint) pressure, since a good part of the internal pressure is required to relieve the inner layers of their compression before they are subjected to any tension. The method, at least for some calibers, offers advantages of simplicity, reduced cost and increased production
Ref: Anon, OrdTechTerm (1962), 244

RADIATION EFFECTS ON EXPLOSIVES, PROPELLANTS AND PYROTECHNICS

1. Introduction

The advent of the space age, the testing of intercontinental ballistic missiles, the use of space probes, the existence of radiation belts in outer space, and the increasing utilization of military and civilian satellites have triggered further studies on the effects of nuclear radiation on all types of materials, including expls, propnlts, pyrots and related materials. Nuclear radiation effects studies range from steady-state to transient environments, from ground zero to upper atmosphere levels and from underground nuclear tests to simulation techniques in the laboratory which in turn cover all phases of vulnerability and survivability

Ever since Henderson in 1922 (Ref 1) postulated that α -particles might be used as "detonators" the interest in the effects of nuclear radiation on expls and other reactive materials has centered around the question as to whether self-sustaining exothermic reactions could be initiated in these materials when exposed to various types of nuclear radiation of different energies. Although the interest still persists, the scope has broadened to determine the effects of radiation on many of the properties of the materials. The microscopic aspects of the effects of radiation are described in detail elsewhere (Refs 145 & 256). This article is devoted to the effects, changes, damage or decompn on a macroscopic scale. Physical and chemical changes in solids caused by nuclear irradiation have been studied and the effect on performance is still the most important practical requisite. For a general background there are many references on the interaction of radiation with solids or matter (Refs 45, 46, 93, 109, 143, 145 & 146)

The initiations achieved in the early work of Henderson (Ref 1) and Poole (Refs 2 & 3) with nitrogen iodide by α -particles, Kallmann and Schankler (Ref 9) with TNT, MF, NC, picrates and azides by intense beams of hydrogen, argon and mercury ions and also by electrons, and Muraour (Ref 10) with Ag acetylide by high speed electrons, brought forth the possible solution that the explns were caused by activation of a few neighboring molecules

However, this does not meet the criteria of Bowden who stipulated that the size of the "hot spot" required to develop an expln must be greater than $10^{-3} - 10^{-5}$ cm diam (with a temp of 400–500°) and in general this is greater than a few molecules

To implement this Bowden utilized nuclear radiation which provided a convenient means of introducing large amounts of energy into localized regions in crystals of expls to generate the "hot spot". These efforts will be described along with those of other investigators

The radiation – induced changes noted are in weight loss, gas evolution, mechanical sensitivity, thermal sensitivity and stability, and expl performance. The effects will be described with the type of nuclear radiation used. The format describes the radiation effects on expls, propnlts and pyrots with the sequence of radiations utilized (when applicable) as follows: α -particles, neutrons, fission products, reactor radiation (fast and slow neutrons plus gammas), gammas (γ), underground testing (UGT), X-rays, electrons, and other nuclear radiations

2 Radiation Effects on Explosives

a) α -Particle Irradiation

One of the first reports on the irradiation of expls was by Henderson (Ref 1) who reported in 1922 that nitrogen iodide detonated after 20 secs when placed 1 cm away from a radium source. His results also indicated that increasing the size or strength of the source decreased the time to detonation. Poole (Ref 3) achieved the same result and concluded (in agreement with Henderson) that a single α -particle in a flux of $10^7 - 10^8$ was responsible for the expln. However, Poole (Ref 2) stated that for more stable expl materials a more copious source of α -particles would be required

More than a decade later Muraour (Ref 11) reported that nitrogen iodide, picric acid, Pb picrate, TNT, NG, hexogen (RDX), Ag acetylide and Pb azide were subjected to the action of α -rays from polonium with negative results. Details of the expts were not given

Garner and Moon (Ref 12) were the first to report the effects produced by radiation other than color changes. They found the effects pro-

duced by the emission from radium on crystals of Ba azide were very dependent on temp. Garner and Moon concluded that the acceleration in the thermal decompn of Ba azide by the emission from radium was due to an acceleration of the growth of the nuclei and not to an increase in their number. On the other hand the thermal decompn of MF was not affected in the same environment

Haissinsky and Walen (Ref 14) also subjected nitrogen iodide to 5 MeV α - particles from a polonium source. With a dry nitrogen iodide sample he repeated and achieved the same results as Henderson. The degree of dryness and the intensity of the polonium source decreased the time of expln. These investigators stated that "the detonation of nitrogen iodide could be explained by a local heating of a grain of the powder". However they thought this was a specific case since Pb nitride, Ag nitride and diazo-m-nitraniline perchlorate did not detonate under the strongest source (1 millicurie of Po) with 20 minutes exposure. No changes were noted except in Pb nitride where a yellowing of the material was evident.

The same type of test also was conducted by McLaren (Ref 54) in more detail including irradiation in an ammonia atmosphere, and also in a water vapor. Initiation was inhibited by the ammonia and water vapor environments. McLaren questioned the theory put forth by Poole and Henderson that a single α - particle caused the detonation

Although the results by McLaren indicate that the time to expln decreases as the intensity increases, the total number of α - particles required is not constant. McLaren stipulated that, while the range of α - particles in nitrogen iodide is greater than 40 μ , the inhibition of ammonia and also water vapor to permit expln eliminates a bulk effect, ie, the action of α - particles absorbed within the bulk of the nitrogen iodide, but support a surface effect. McLaren suggested that the mechanism of initiation is the removal of ammonia (which served as a stabilizer) from the surface of nitrogen iodide by the α - particles causing an expln at room temp resembling the thermal ignition of nitrogen iodide

Bowden and Singh (Refs 28 & 35) irradiated Pb azide, Cd azide, Ag azide, Li azide and Ag acetylide with α - particles but failed to cause

expln in any of the materials. The effects were not noted; however, Bowden (Ref 57) later reported that one of his co-workers, Camp, using high resolution electron spectroscopy, had observed that the passage of a single α - particle thru Ag azide will liberate a very large amount of metallic Ag

The heavy-particle irradiation of expls revealed the need for accurate range-energy relations for those materials. Ling (Ref 50) had calcd ranges in several expls for α - particles and fission fragments. Although an error was subsequently found in the α - particle calcs (thus making them inapplicable (Ref 109)), the results showed that both types of particles have greater ranges in Cu chlorotetrazole, K dinitrobenzofuroxan (KDNBF), and nitrogen iodide than other expls such as Pb azide, Pb styphnate, TNT, RDX and PETN. The results were interpreted to mean that the greater range increased the probability of reaching the sensitive spots of an expl, thus giving some insight on the problem of sensitivity of expls. Ling also concluded that, assuming complete thermalization of energy transferred in nuclear collisions, a fission fragment was more efficient in causing ignition than an α - particle of the same incident energy

Cerny et al (Ref 109) calcd range-energy relations for protons and α - particles in RDX and HMX, Pb styphnate and Pb azide, as shown in Fig 1. The α - particle ranges were obtained from established proton ranges; the difference in range caused by variations in electron capture and loss were estimated from the known value for air by assuming that this effect depended only on the molecular electron density

b) Neutron Irradiation of Explosives

Studies of the effect of neutron irradiation are divided into three groups: slow or thermal neutrons, fission products and reactor neutrons. The slow neutrons are obtained from a radioactive source or high energy neutrons that are produced by deuterium bombardment of a beryllium target in a cyclotron and slowed down passing thru a thick paraffin wax block. The fission products in one case are produced when a desired sample is mixed or coated with uranium oxide and subsequently irradiated with slow neutrons. The capture of neutrons by U^{235} leads

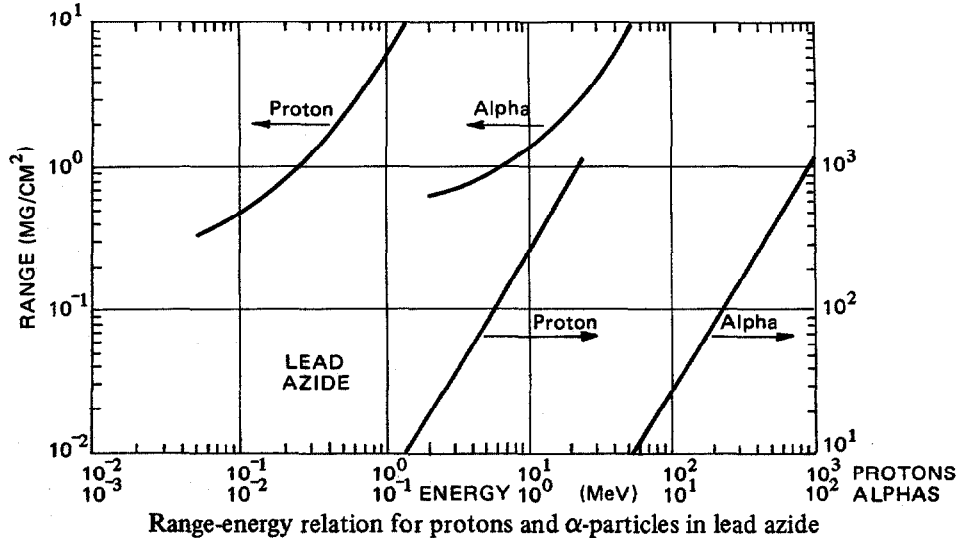
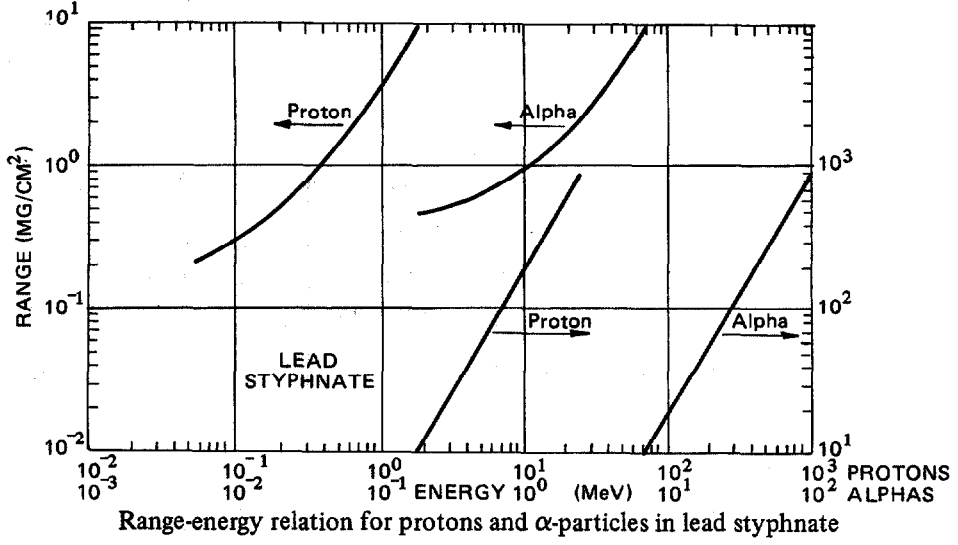
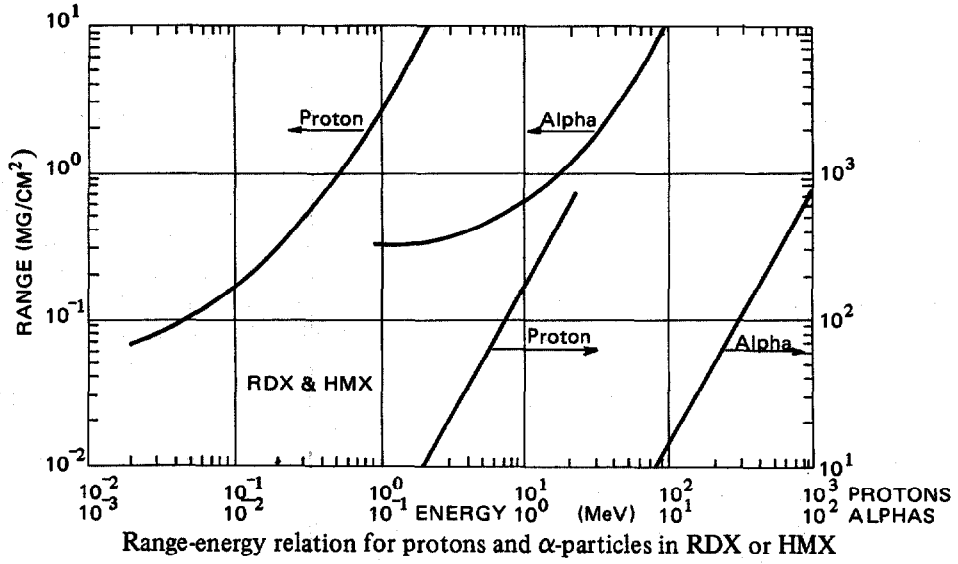

Fig 1 Range-Energy Relation for Protons and α -Particles in Several Explosives (Ref 109)

to its fission with about one-half of the fission fragments formed within a layer 1μ in thickness entering the crystals. The reactor irradiation consists of three nuclear components: fast neutron $> 10\text{KeV}$, slow thermal neutrons, and gamma (γ) radiations

Slow Neutron

Bowden and Singh (Refs 8 & 35) utilized a radioactive antimony-beryllium source with a slow neutron flux of about 10^6 neutrons/cm²/sec and the cyclotron at Cavendish Laboratory for fluxes up to 3×10^8 n/cm²/sec. The primary expls listed in Table 1 were irradiated for one hour so that the maximum total slow neutron dose was 1.08×10^{12} neutron/cm². The results show that in most cases a large number of high-velocity recoil atoms are formed on the irradiation of these expls with slow neutrons. In no case did any of the expls deto-

nate as a direct result of the slow neutron irradiation. This included nitrogen iodide

The effects of slow neutron irradiation caused color changes and darkening in most of the expl crystals, indicating the formation of F centers and nuclei, and subsequently affected the thermal decompns of the expls. The rates of thermal decompn as measured by pressure-time curves for irradiated Pb azide are shown in Fig 2. With Li azide the effect of pre-irradiation with slow neutrons is to cut down the induction period to about one-half and to increase the rate of decompn considerably

With Pb azide the irradiation increased the rate of thermal decompn, but the effect was not as pronounced as Li azide.

Cd azide produced pressure-time curves similar to Pb azide. Irradiated Ag azide did not show any acceleration, but this may be due to the

Table 1
Slow Neutron Irradiation of Primary Explosives (Ref 35)

Explosive	Density (g/ml)	Flux (n/cm ² /sec)	Total atoms (per ml)	Metal nuclei reacting (per sec)	Nitrogen nuclei reacting (per sec)	Nuclear reaction
Cadmium azide	0.729	3×10^8	1.56×10^{22}	3×10^8	6×10^6	$^{14}\text{N}(n,p)^{14}\text{C}$, 0.6MeV protons, 40KeV ^{14}C recoil $^{113}\text{Cd}(n, \gamma)$, ^{114}Cd , 5.1 MeV γ cascade
Lithium azide	0.570	7×10^7	4.01×10^{22}	2×10^7	2×10^6	Nitrogen reaction: $^6\text{Li}(n,\alpha)^3\text{H}$, 2.1 MeV α and 2.7 MeV ^3H
Silver acetylide	0.381	3×10^7	3.8×10^{21}	$^{107}\text{Ag} 7 \times 10^5$ $^{109}\text{Ag} 2 \times 10^6$		$^{107}\text{Ag}(n,\gamma)^{108}\text{Ag}$, 4.5 MeV γ cascade $^{109}\text{Ag}(n,\gamma)^{110}\text{Ag}$, 10 MeV γ cascade Principal decay processes: ^{108}Ag , 2.12 MeV β , 0.6 MeV γ ; ^{110}Ag , 2.8 MeV β
Silver azide	0.745	1×10^8	1.21×10^{22}	$^{107}\text{Ag} 4 \times 10^6$ $^{109}\text{Ag} 1 \times 10^7$	1×10^6	Silver and nitrogen reactions
Lead azide	1.875	2×10^7	2.71×10^{22}	17	8×10^5	Lead reactions unimportant, nitrogen reaction
Nitrogen iodide	1.40	6×10^6	1.64×10^{22}	$^{127}\text{I} 5 \times 10^5$	4×10^4	$^{127}\text{I}(n,\gamma)^{128}\text{I}$, 8.5 MeV γ Principal decay process: ^{128}I , 2.1 MeV β

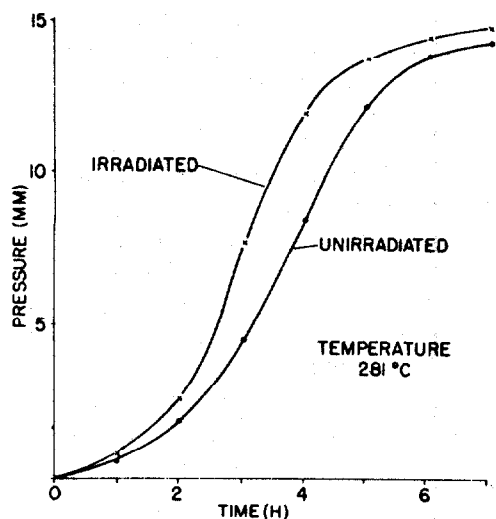

Fig 2 The Effect of Slow Neutron Irradiation on the Subsequent Thermal Decomposition of Lead Azide (Ref 28)

fact that the expt was conducted at 315° which caused Ag azide to be in a molten state

Fission Products

The detonation of nitrogen iodide by nuclear fission was first reported by Feenberg (Ref 13). Small samples of nitrogen iodide mixed with black uranium oxide were exposed to a 200mg Ra-Be neutron source surrounded by 6cm of paraffin. A typical sample contd 1/2g uranium

oxide while the average exposure time required to produce detonation was 40 mins ranging from one min to several hours. Similar results were obtd by Fabre et al (Ref 15)

A more detailed set of expts were conducted by Bowden and Singh (Refs 32 & 57). Crystals of Pb azide, Cd azide and nitrogen iodide coated with uranium oxide were irradiated with slow neutrons. The approx number of fission fragments entering the expl crystals is given in Table 2. The only material that expld was nitrogen iodide. Pb azide and Cd azide were bombarded with fission fragments at elevated temps with the max at 290° for Pb azide which is about 40° below its expln temp. No expls were obtained with either Cd or Pb azide. In these expts the energy of the fission products was about 94 MeV while the range of these particles was estimated at about 10⁻³cm.

The elevated temp environment was used to have the effect of increasing the size of the hot spot based on the assumption that the initiation of expln by bombarding particles is primarily thermal

The extent of the damage in an expl crystal caused by a fission fragment was investigated by Bowden and his co-workers, Montagu-Pollock and Chadderton (Refs 88, 89, 95-97 & 106). Electron microscope studies showed that the damage, which is readily visible, depends upon the nature of the crystal and on other factors (Ref 106). The disorder is produced in the

Table 2
Fission-Fragment Irradiation of Explosive Azides (Ref 57)

Sample ^a	Flux (m/cm ² sec)	²³⁵ U atoms per ml coating	Fissions per ml sample per hour	Result	
Nitrogen iodide	2 x 10 ⁶	6 x 10 ¹⁶	2 x 10 ⁵	Explosion	
	4 x 10 ⁶	6 x 10 ¹⁶	4 x 10 ⁵	Explosion	
Lead azide	150°C	3 x 10 ⁷	7 x 10 ¹⁷	4 x 10 ⁷	No explosion
	225°C	4 x 10 ⁷	7 x 10 ¹⁷	5 x 10 ⁷	No explosion
	280°C	3 x 10 ⁷	7 x 10 ¹⁷	4 x 10 ⁷	No explosion
	290°C	2 x 10 ⁷	7 x 10 ¹⁷	4 x 10 ⁷	No explosion
Cadmium azide	280°C	2 x 10 ⁷	3 x 10 ¹⁸	2 x 10 ⁸	No explosion
	280°C	2 x 10 ⁷	3 x 10 ¹⁸	1 x 10 ⁸	No explosion

^aCoated with 1 μm ²³⁵U

lattice and the holes and tunnels formed indicated that the track width may be approx 100–120Å. With the damage interpreted as a thermal mechanism, these investigators concluded that even the intersection of two tracks would not produce initiation or expln in an azide crystal, while the intersection of three or more tracks within 10^{-11} sec was an unlikely event

A detailed analysis of the "hot spot" model was attempted by Cerny and Kaufman (Ref 128) who irradiated several expls with π^- mesons (pions). High, local energy densities in roughly spherical shape can be formed from slow pion bombardment of solids

The formation and destruction of the mesonic atoms formed by the capture of π^- mesons can result in the emission of $\sim 12-17$ charged particles from a single lattice site. The estimation was made that a temp of 10^4° would be produced over a 10Å radius for a period of 10^{-11} seconds. The calcs indicated that the high temp would quickly decrease but that the radius of the heat site would broaden and meet the criteria set forth by Bowden for a hot spot

However, when Pb azide, Pb styphnate, MF, RDX, TNT, and PETN were subjected to bombardment with a negative pion beam, no explns or decompns were observed for any of the expls. The analysis had predicted initiation only for RDX. Also it had indicated that nuclear fission events would produce higher energy densities and greater temp increases than were actually observed

Subsequently an extreme test of the hot spot model as applied to microscale thermal effects of ionizing radiation was proposed by Mallay, Prask and Cerny (Ref 129). RDX, HMX, PETN and NG were irradiated with fission fragments from the spontaneous fission of californium-252 at elevated temps (160° , 215° , 125° and 180° , respectively). The californium-252 was mixed thruout the expl pellet or liq (for NG). No explns were obtained nor any signs of accelerated thermal decompn were evident at the elevated temps or when heated to ignition although the irradiated expls were exposed to 200–2000 fission fragments

Since a detailed quantitative analysis of the resulting cylindrical zones of radiation heating and subsequent behavior with time predicted initiation with all of the expls irradiated, the

investigators concluded that the hot spot model was inadequate in describing the effects of micro-scale events in expl materials. In rebuttal Boddington, Bowden, Chadderton and Yoffe (Ref 129) indicated that the calcs to determine the temp and behavior of a hot spot formed in an expl crystal by the passage of a fission fragment may not have included all of the proper assumptions and parameters. Although agreement was indicated regarding an inadequacy of the thermal expl theory when applied to fission-fragment bombardment of expl solids, the belief was that proper calcs could not be made since the necessary parameters under those extreme conditions were still not known

Reactor Irradiations

Steady-State

A nuclear reactor is usually the source of fast and thermal neutrons. These reactor neutrons are always accompanied by a gamma-ray field so that a material exposed in a reactor is subjected to the accumulated radiation effect ^a

Muraour and Ertand (Ref 29) exposed several primary expls in the atomic pile Zoe at Chatellon, France. Pb azide, MF, diazo meta nitraniline perchlorate, Pb trinitroresorcinat, and tetracene were subjected to total steady-state thermal neutron fluxes up to 10^{13} neutrons/cm². The γ component was not given. No explns were obtained with any of the materials during irradiation. The only effect noticed was a slight color change from white to light brown in tetracene. The Pb azide was exposed to a total thermal neutron dose of 3×10^{14} n/cm²

Although Muraour and Ertand stated that they had substantiated the results of Bowden and Singh (Refs 28 & 35), a different environment was used. It should be noted that the former utilized reactor irradiation at higher dose rates and doses as compared to the slow thermal neutron irradiation for the latter. For example the thermal neutron dose rate for Pb azide was 4.2×10^9 compared to 2×10^7 n/cm²/sec and the total dose was 3×10^{14} compared to 7.2×10^{10} n/cm²

^a The gamma (γ) radiation exposure units used to express radiation doses are as follows:

$$\begin{aligned} 1 \text{ R (roentgen) (of dry air)} &= 87.7 \text{ ergs (absorbed)/g (C)} \\ &= 87.7 \times 10^{-7} \text{ J/g (C)} \\ 1.14 \text{ R} &= 100 \text{ ergs/g (C)} \\ &= 92 \text{ erg/g (Si)} \\ &= 10^{-5} \text{ J/g (C)} \\ &= 1 \text{ rad} \end{aligned}$$

In a study conducted by the Armour Research Foundation (Ref 41) α -Pb azide crystals wrapped in a thin Al foil were subjected to fast and thermal neutrons in the heavy water pile at Argonne National Laboratory. With a thermal flux rate of about 10^{14} n/cm²/sec the crystals were irradiated for 8, 17 and 170 hours. The crystals decompd to a brown powder which was identified as Pb carbonate by X-ray techniques and infrared absorption spectra. From a mass spectrographic analysis of the isotopes of carbon and oxygen in the decompn products, it was determined that the mechanism of carbonate formation is a reaction with the atmosphere by broken surface bands produced by the neutrons. Subsequently, Raney (Ref 60) reported

that the total dose required for conversion to Pb carbonate is approx 7.5×10^{16} n/cm²

The effect of reactor irradiation on the thermal decompn of Pb styphnate monohydrate was studied by Flanagan (Ref 61). He observed that a total neutron exposure of 2.2×10^{18} n/cm² in the Brookhaven National Laboratory reactor enhanced the decompn rate by a factor of three as shown in Fig 3 with the decompn rate increasing monotonically with the amount of exposure. Flanagan also noted that a sample decompd 8 days after irradiation produced a decompn curve almost identical with one stored 46 days after irradiation and then decompd. Subsequently Flanagan (Ref 105) showed that the activation energy was significantly decreased

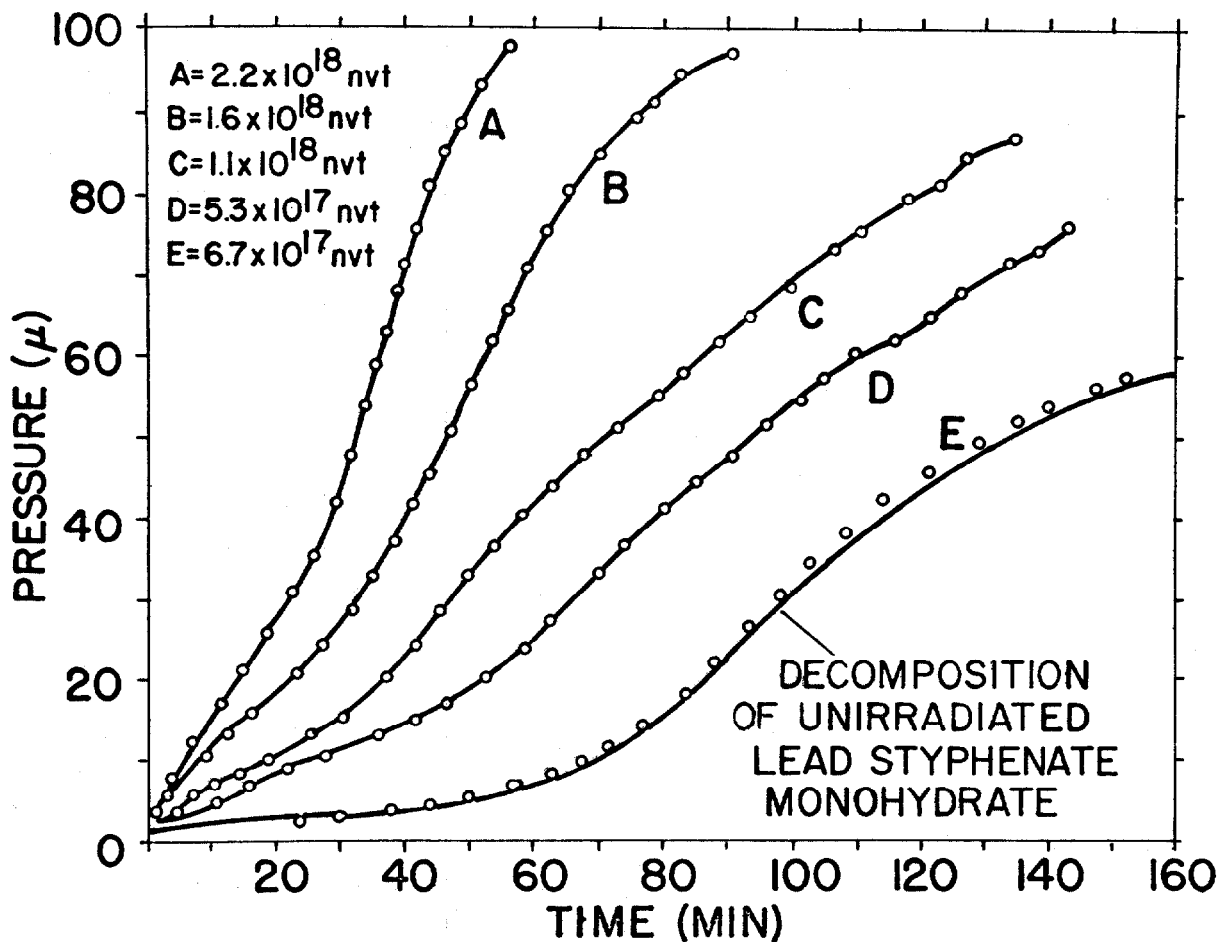

Fig 3 The Thermal Decomposition Curves of Reactor-Irradiated Pb Styphnate Monohydrate (222.5°) (Ref 61)

by reactor irradiation

Grocock (Ref 59) irradiated α -Pb azide for 5 hrs in the Harwell BEPO pile. The doses were not given, but the decompn curves were similar to those for the same material subjected to X-rays for a total dose of 6.35×10^6 R. Assuming the thermal neutron rate to be 6×10^{11} n/cm²/sec, the approx total neutron dose was 1.08×10^{16} n/cm². The 5-hr exposure lowered the expln temp 15–20°. Grocock also made calcs indicating the amount of nuclear energy required in one second to initiate certain expls, ie, 3×10^9 ergs/g (3.42×10^7 R) for HMX

In a joint program conducted between PicArns and Brookhaven National Laboratory, Abel et al (Refs 49 & 63) studied the effect of reactor and gamma-ray irradiation on the impact sensitivity of colloidal Pb azide. With reactor irradiations ranging from 3.3×10^{17} to 1.57×10^{18} nvt (n/cm²) (fast plus slow neutrons) and the accompanying reactor gamma dose rate of 2×10^6 R/hr the effects are shown in Fig 4. The results indicate that there is a definite increase in the impact sensitivity of colloidal Pb azide as a function of total neutron dose. The studies

also revealed the incompatibility of colloidal Pb azide with Teflon and Al during long-term reactor exposures

Mapes et al (Ref 75) irradiated Composition 9404, a NC-bonded HMX expl, in the Brookhaven reactor to a cumulative dose of 1.2×10^{15} nvt (fast plus thermal) with a 10^6 R gamma component. This expl was irradiated in pellet form and showed only small changes in the dimensions of the pellet

Jach (Refs 110, 111, 166 & 167) studied the effect of extensive reactor irradiation on the thermal decompn of colloidal α -Pb azide (average particle size 7μ). It was irradiated for 35 hours in the Brookhaven reactor with a flux rate (fast plus slow neutrons) of approx $7-8 \times 10^{12}$ n/cm²/sec and a gamma component of 2×10^6 R/hr

Fig 5 shows that reactor irradiation significantly alters the decompn kinetics. The induction period is drastically reduced, the acceleratory period is absent and the max rate and decay rate increased. The max rate of final decay normally occurred at about 40% decompn, but this shifted to about zero time upon irradiation.

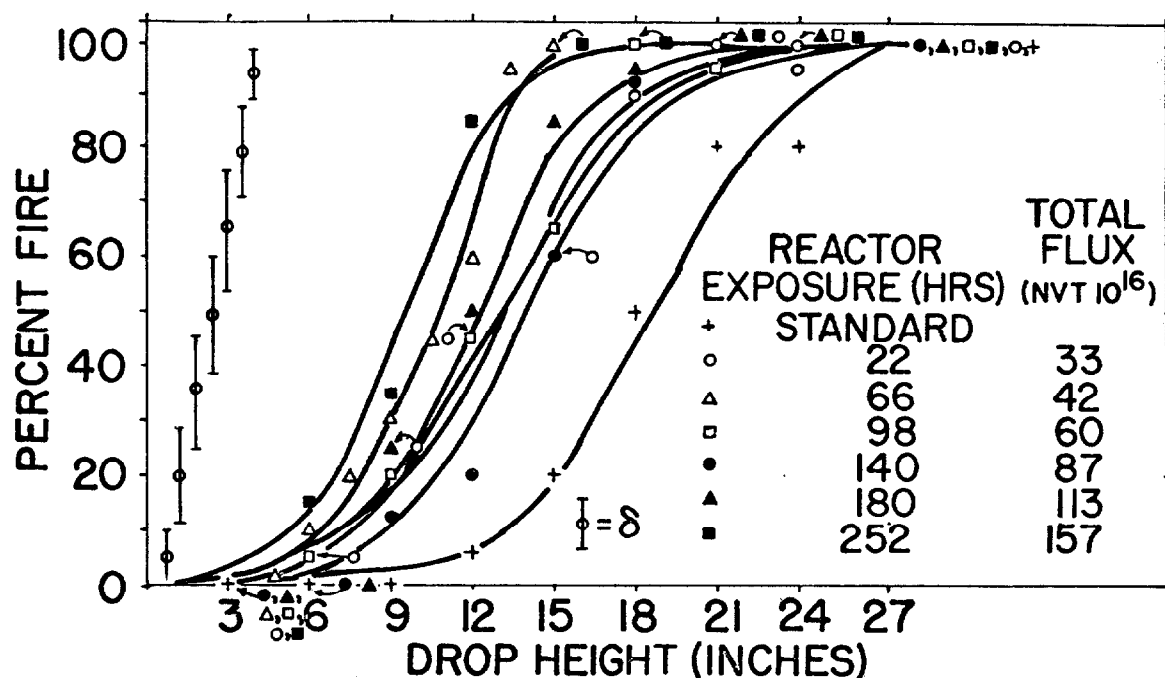

Fig 4 The Effect of Reactor Irradiation on Impact Sensitivity, Colloidal Pb Azide (Ref 49); Picatinny Arsenal Impact Test, 2-kg Weight, 20 Trials for Height

The change in decay rate or irradiation is given by the two rate constants,

$$K(\text{unirradiated}) = 10^{12.0 \pm 1.0} \exp(-15.2 \pm 0.10 \text{ MJ/RT})$$

$$\text{or } 10^{12.0 \pm 1.0} \exp(-36.3 \pm 2.3 \text{ kcal/RT})$$

$$K(\text{irradiated}) = 10^{7.9 \pm 1.0} \exp(-1.07 \pm 0.10 \text{ MJ/RT})$$

$$\text{or } 10^{7.9 \pm 1.0} \exp(-25.7 \pm 2.4 \text{ kcal/RT})$$

Jach suggested that the decrease in activation energy is associated with a change in electronic excitation energies, while the decrease in frequency factor arose from gross structural changes accompanying the reactor irradiation

Since the effect of nuclear radiation on expls has been a subject of considerable interest from both the research and engineering points of view,

it was not surprising that the trends developed for more detailed analyses with higher total neutron fluxes and rates as shown in the work of Urizar, Loughran and Smith (Ref 98) and later with the results reported by Avrami and Voreck (Ref 192)

In one of the more extensive programs, Urizar et al (Ref 98) exposed a number of secondary expl compds and mixts to two fluence levels (10^{15} n/cm^2 with $5 \times 10^6 \text{ R}$ and $3 \times 10^{16} \text{ n/cm}^2$ with $2 \times 10^8 \text{ R}$) in the Ground Test Reactor at Convair, Fort Worth, Texas. The expl materials involved were TNT, Tetryl, NC, RDX, HMX, PETN, Composition B, and three plastic-bonded

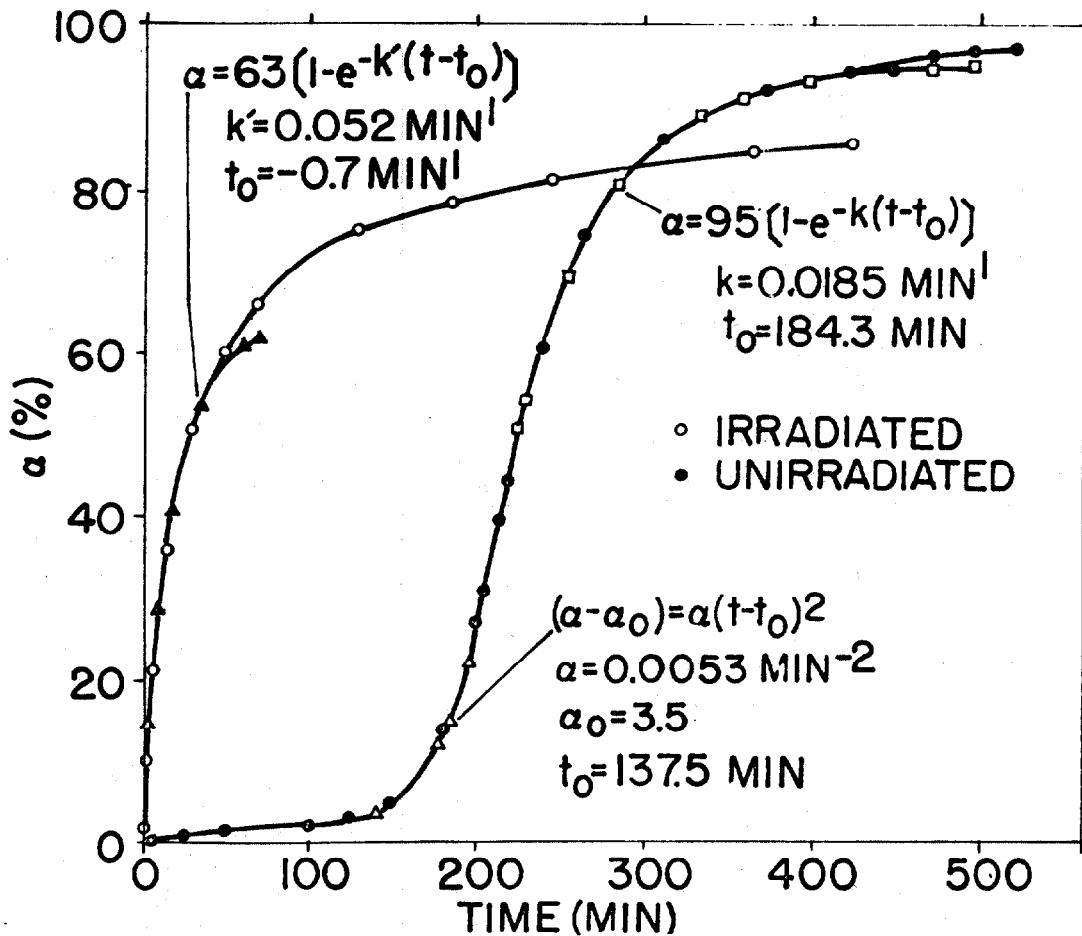

Fig 5 The Effect of Reactor Irradiation on the Thermal Decomposition of Colloidal α -Pb Azide. (Ref 110). Fraction of total decomposition α against time. Solid circles: experimental points for unirradiated material at 240.9°C ; open circles; experimental points for irradiated material at 238.5°C ; other points are the attempted fits indicated by arrows

Table 3
Weight Loss by Reactor Irradiated Explosives (Ref 98)

Explosive	Percent weight loss for various exposures			Percent change in particle or crystal density
	10^{15} nvt (-80°F)	10^{15} nvt (100°F)	10^{16} nvt (-80°F)	10^{16} nvt (-80°F)
TNT	0.3	0.2	0.3	0.6
Tetryl	0.0	0.0	1.3	1.7
Comp B	0.1	0.1	7.8	12.6
Nitrocellulose	0.4	0.9	9.0	—
HMX	0.2	0.2	9.1	18.2
9404	0.1	0.1	9.2	8.3
9010	0.1	0.1	11.8	14
9407	—	—	13.4	9.8
PETN	0.2	0.2	13.8	17.9
RDX	0.1	0.2	14.3	17.6

expls mixts 9404, 9010 and 9407. A variety of physical and chemical tests were performed on the irradiated samples. Dosimetry, followed by energy deposition calcns, revealed that about 90% of the energy deposited was due to the gamma field (2×10^8 R at the higher dose level). G-values (number of molecules destroyed per 100 ev of absorbed energy) calcd on the basis of weight loss and gas evolution ranged from less than 0.1 for TNT, 1.4 for HMX, to about 3 for RDX. NC exposed at the higher level was badly decompd and continued to decomp at a significant rate following the irradiation. It was also observed that several of the materials, notably RDX and HMX, continued to evolve small amounts of gas for days following the exposure. Trapped-gas measurements on irradiated crystals showed that a significant amount of radiolytic gases ($\sim 9\text{cm}^3/\text{g}$) remained in the irradiated crystals. The weight, density and dimensional changes were small for the 10^{15} n/cm² exposure, but were significant for the 10^{16} exposure. A summary of the changes in weight and crystal or particle density is given in Table 3. Although properties such as melting points, phase transition temps and densities were lowered, no significant evidence of sensitization to impact initiation was observed

Berberet (Ref 121) in 1963 analyzed the

Urizar data and the state-of-the-art regarding the ignition of expls by irradiation. Berberet also made calcns (Ref 123) on the atomic displacements by heavy particles, including neutrons, in high expls composed of light elements. Problems associated with the reactor irradiation of a 60–80 gram expl sample were also included

An extensive study on the effects of nuclear reactor irradiations on selected expls and proplnts was undertaken as a joint Aerojet-General/General Electric/PicArns effort (Refs 154, 155, 159, 165, 176 & 192) for NASA as part of the NERVA (Nuclear Engine for Rocket Vehicle Applications) program. Avrami and Voreck (Ref 192) have summarized the data from all phases of this program and have included results and analyses of their own expts in the report

This latter work, together with that of Urizar et al (Ref 98) constitutes the most significant and complete exptl information in the field of steady-state nuclear radiation of energetic materials. Since a wide variety of energetic substances were studied in these programs, sufficient data on the radiation stability of specific materials was made available to engineers to allow selection of suitable candidates for applications in a nuclear environment

Thirty-two substances, including three primary expls, eight booster expls, eight secondary expls,

Table 4
Effects of Reactor Irradiation on Some Explosives (Ref 192)

Irradiation time (min)	Total neutron dose ^a		Total gamma (R)	Weight loss (%)	10% Loss on TGA (°C)	200°C avg gas evolution (ml/g/hr)	DTA peak exotherm at 20°C/min (°C)	5-sec explosion temperature (°C)
	Fast (n/cm ²)	Thermal (n/cm ²)						
A. Primary explosives								
KDNBF								
0	—	—	—	—	210	2.55 ^a	212 ^b	194
60	5.0x10 ¹⁶	3.1x10 ¹⁷	4.0x10 ⁸	0.46	188	10.95 ^c	198 ^b	185
120	1.0x10 ¹⁷	6.2x10 ¹⁷	8.0x10 ⁸	1.52	188	11.0 ^c	188 ^b	170
180	1.5x10 ¹⁷	9.3x10 ¹⁷	1.2x10 ⁹	4.84 ^c	175	11.0 ^c	182 ^b	169
Silver tetracene								
0	—	—	—	—	—	0.26 ^c	380 ^b	375
38	3.1x10 ¹⁶	2.1x10 ¹⁷	2.3x10 ⁸	7.52	—	4.02 ^c	360	247
126	1.0x10 ¹⁶	6.3x10 ¹⁷	8.0x10 ⁸	23.6	—	5.92 ^c	315	214
Lead styphnate								
0	—	—	—	—	285	1.02	287 ^b	299
~2	1.7x10 ¹⁵	1.1x10 ¹⁶	1.4x10 ⁷	—	—	Sample detonated	—	—
~1msec	7.3x10 ¹³	2.2x10 ¹⁴	3.6x10 ⁶	0.26	—	2.53	270	268
~1msec	3.5x10 ¹⁴	1.6x10 ¹⁵	1.5x10 ⁷	—	—	Sample detonated	—	—
B. Booster explosives								
ABH								
0	—	—	—	—	361	0.49	376	385
180	1.4x10 ¹⁷	9.0x10 ¹⁷	1.4x10 ⁹	4.20	259	11.6	343	293
356	3.0x10 ¹⁷	1.8x10 ¹⁸	2.9x10 ⁹	6.10	275	27.5	345	247
HNAB								
0	—	—	—	—	341	0.10	352	373
120	8.6x10 ¹⁶	5.7x10 ¹⁷	7.6x10 ⁸	1.76	272	8.65	353	363
180	1.5x10 ¹⁷	9.3x10 ¹⁷	1.2x10 ⁹	3.77	311	12.43	353	329
323	2.5x10 ¹⁷	1.6x10 ¹⁸	2.5x10 ⁹	7.27	252	23.40	340	306

continued

Table 4 (Cont'd)

Irradiation time (min)	Total neutron dose ^a		Total gamma (R)	Weight loss (%)	10% Loss on TGA (°C)	200°C avg gas evolution (ml/g/hr)	DTA peak exotherm at 20°C/min (°C)	5-sec explosion temperature (°C)
	Fast (n/cm ²)	Thermal (n/cm ²)						
HNS								
0	—	—	—	—	317	0.02	343	382
120	9.4x10 ¹⁶	6.0x10 ¹⁷	8.4x10 ⁸	2.36	276	16.0	341	307
180	1.6x10 ¹⁷	9.5x10 ¹⁷	1.2x10 ⁹	4.28	323	21.6	335	251
240	1.9x10 ¹⁷	1.2x10 ¹⁸	1.6x10 ⁹	5.71	255	22.8	330	256
~1 msec	7.4x10 ¹³	2.2x10 ¹⁴	3.0x10 ⁶	0.11	—	0.19	357	388
~1msec	3.0x10 ¹⁴	1.0x10 ¹⁵	1.5x10 ⁷	0.13	336	0.18	360	388
NONA								
0	—	—	—	—	316	0.58	397	436
120	8.3x10 ¹⁶	6.3x10 ¹⁷	8.4x10 ⁸	2.57	—	11.02	365	360
198	1.5x10 ¹⁷	1.1x10 ¹⁸	1.4x10 ⁹	5.11	—	6.47	360	303
240	2.2x10 ¹⁷	1.2x10 ¹⁸	1.8x10 ⁹	6.72	265	11.7	360	279
360	2.6x10 ¹⁷	1.7x10 ¹⁸	2.6x10 ⁹	9.87	248	40.05	369	231
DIPAM								
0	—	—	—	—	—	0.21	292	371
122	9.5x10 ⁶	6.5x10 ¹⁶	8.5x10 ⁸	2.34	—	3.60 ^c	282	287
182	1.4x10 ¹⁷	9.5x10 ¹⁶	1.2x10 ⁹	4.44	—	5.17 ^c	276	252
HNDS (DPS)								
0	—	—	—	—	288	0.14	343	387
120	1.0x10 ¹⁷	6.1x10 ¹⁷	8.2x10 ⁸	8.16	175	19.10 ^c	281	181
187	1.5x10 ¹⁷	9.1x10 ¹⁷	1.3x10 ⁹	11.2	200	22.10 ^c	230	177
Tetryl								
0	—	—	—	—	—	—	—	—
25	2.2x10 ¹⁶	1.2x10 ¹⁷	1.9x10 ⁸	2.14	—	—	—	—
125	1.0x10 ¹⁷	—	8.8x10 ⁸	—	Sample ignited	—	—	—

continued

Table 4 (Cont'd)

Irradiation time (min)	Total neutron dose ^a		Total gamma (R)	Weight loss (%)	10% Loss on TGA (°C)	200°C avg gas evolution (ml/g/hr)	DTA peak exotherm at 20°C/min (°C)	5-sec explosion temperature (°C)
	Fast (n/cm ²)	Thermal (n/cm ²)						
PETN								
0	—	—	—	—	—	—	233 ^d	—
9.74	3.2x10 ¹⁵	1.1x10 ¹⁶	3.6x10 ⁷	6.07	—	—	234 ^d	—
8.7	7.4x10 ¹⁷	3.6x10 ¹⁶	6.1x10 ⁷	3.65	—	—	229 ^d	—
25	1.9x10 ¹⁶	1.0x10 ¹⁷	1.8x10 ⁸	10.53	—	—	227 ^d	—
C. Secondary explosives								
TATB								
0	—	—	—	—	359	0.06 ^c	388 ^b	392
135	9.4x10 ¹⁶	6.9x10 ¹⁷	9.5x10 ⁸	0.45	—	1.05	365	287
184	1.5x10 ¹⁷	1.0x10 ¹⁸	1.2x10 ⁹	0.79	—	5.44 ^c	360	253
240	2.1x10 ¹⁷	1.2x10 ¹⁸	1.6x10 ⁹	1.41	283	12.7	361	255
600	5.0x10 ¹⁷	3.0x10 ¹⁸	4.3x10 ⁹	1.64	247	11.28	348	233
TACOT								
0	—	—	—	—	409	0.22 ^e	390	417
36	2.4x10 ¹⁶	1.8x10 ¹⁷	2.5x10 ⁸	0.26	—	0.53 ^e	390	415
136	1.0x10 ¹⁷	7.1x10 ¹⁷	8.6x10 ⁸	1.03	—	0.51	388	374
180	1.4x10 ¹⁷	8.8x10 ¹⁷	1.2x10 ⁹	—	371	3.35	388	379
240	1.9x10 ¹⁷	1.1x10 ¹⁸	1.6x10 ⁹	1.78	356	4.33	388	352
593	4.6x10 ¹⁷	2.9x10 ¹⁸	4.2x10 ⁹	6.58	275	8.96	366	247
~1msec	2.9x10 ¹⁴	1.2x10 ¹⁵	1.5x10 ⁷	—	392	0.33	405	395
~1msec	7.2x10 ¹³	1.9x10 ¹⁴	3.0x10 ⁶	0.27	404 ^b	0.12	400	391

continued

Table 4 (Cont'd)

Irradiation time (min)	Total neutron dose ^a		Total gamma (R)	Weight loss (%)	10% Loss on TGA (°C)	200°C avg gas evolution (ml/g/hr)	DTA peak exotherm at 20°C/min (°C)	5-sec explosion temperature (°C)
	Fast (n/cm ²)	Thermal (n/cm ²)						
DATB								
0	—	—	—	—	287	0.17	354	403
25	2.2x10 ¹⁶	1.1x10 ¹⁷	1.8x10 ⁸	0.15	284	—	376 ^d	—
126	9.3x10 ¹⁶	6.5x10 ¹⁷	8.0x10 ⁸	0.27	274	4.48 ^c	355	344
180	1.4x10 ¹⁷	9.1x10 ¹⁷	1.2x10 ⁹	1.18	255	11.15	353	342
300	2.3x10 ¹⁷	1.5x10 ¹⁸	2.1x10 ⁹	3.60	260	12.88	345	301
574	4.5x10 ¹⁷	2.9x10 ¹⁸	3.8x10 ⁹	7.97	248	17.70	348	271
~1msec	7.3x10 ¹³	2.3x10 ¹⁴	3.0x10 ⁶	0.09	289	0.04	278	396
~1msec	3.5x10 ¹⁴	1.9x10 ¹⁵	1.5x10 ⁶	0.17	293	0.05	278	391
TNN								
0	—	—	—	—	278	0	375	378
40	5.6x10 ¹⁶	3.6x10 ¹⁷	4.1x10 ⁸	0.13	249	3.04	381	372
81	1.2x10 ¹⁷	7.5x10 ¹⁷	8.4x10 ⁸	4.59	287	6.20	368	325
ONT								
0	—	—	—	—	338	0	395	409
30	4.4x10 ¹⁶	2.8x10 ¹⁷	3.1x10 ⁸	0.52	361	1.68	393	369
54	7.1x10 ¹⁶	4.8x10 ¹⁷	5.6x10 ⁸	3.00	335	2.80	393	352
TNB								
0	—	—	—	—	187	—	123, 353 ^f	449
20	2.7x10 ¹⁶	1.8x10 ¹⁷	2.1x10 ⁸	1.24	218	—	118, 356 ^f	~487
40	5.8x10 ¹⁶	3.6x10 ¹⁷	4.1x10 ⁸	4.63	198	—	113, 355 ^f	~400
TNT								
0	—	—	—	—	—	—	346 ^d	—
125	1.6x10 ¹⁶	1.4x10 ¹⁷	2.3x10 ⁸	0.78	195	—	334 ^d	—
25	2.1x10 ¹⁶	1.3x10 ¹⁷	1.6x10 ⁸	0.92	195	—	329 ^d	—
HMX/EXON								
0	—	—	—	—	—	—	308	—
8.7	7.5x10 ¹⁵	3.7x10 ¹⁶	6.1x10 ⁷	2.34	275	—	303	—
25	2.2x10 ¹⁶	1.1x10 ¹⁷	1.7x10 ⁸	10.43	257	—	299	—

R 18

continued

Table 4 (Cont'd)

Irradiation time (min)	Total neutron dose ^a		Total gamma (R)	Weight loss (%)	10% Loss on TGA (°C)	200°C avg gas evolution (ml/g/hr)	DTA peak exotherm at 20°C/min (°C)	5-sec explosion temperature (°C)
	Fast (n/cm ²)	Thermal (n/cm ²)						
D. Igniters								
Black Powder								
0	—	—	—	—	282	1.30 ^c	332	324
37	2.9x10 ¹⁶	2.0x10 ¹⁷	2.5x10 ⁸	0.31	—	3.75 ^c	325	337
126	8.4x10 ¹⁶	6.1x10 ¹⁷	7.8x10 ⁸	0.21	—	1.58 ^c	324	298
180	1.4x10 ¹⁷	1.2x10 ¹⁸	1.2x10 ⁹	0.72	304	4.00	323	302
300	2.5x10 ¹⁷	1.5x10 ¹⁸	2.0x10 ⁹	2.04	165	6.30	308	282
619	5.2x10 ¹⁷	3.2x10 ¹⁸	4.2x10 ⁹	5.39	226	8.23	306	268
~1msec	7.4x10 ¹³	2.3x10 ¹⁴	3.0x10 ⁶	0.05	315	1.58 ^c	333	330
~1msec	3.0x10 ¹⁴	1.1x10 ¹⁵	1.5x10 ⁷	-0.07	325	0.45 ^c	340	335
ALCLO								
0	—	—	—	—	500+	0.80	457	> 600
67	5.2x10 ¹⁶	3.37x10 ¹⁷	5.2x10 ⁸	1.05	—	7.23	489	~580
120	9.4x10 ¹⁶	5.8x10 ¹⁷	9.0x10 ⁸	5.80	500+	1.94	488	~571

^a Average reactor exposure rates: fast neutrons $\phi > 0.18$ MeV— 1.4×10^{13} n/cm²-sec; thermal neutron $\phi > 0.17$ eV— 8.6×10^{13} n/cm²-sec; gamma 4.0×10^8 R/hr (3.38×10^{10} ergs/g(C)/hr gamma)

^b Sample detonated

^c 150°C

^d @ 10°C/min

^e VST @ 260°C

^f Exotherms only evident

two igniters and eleven proplnts, were subjected to total doses ranging up to 5.0×10^{17} n/cm² fast neutrons, 3.1×10^{18} n/cm² thermal and 4.3×10^9 R gamma. Threshold exposure limits were obtained for many of the materials. The determinations were based on weight loss, vacuum stability tests, gas-release data, expln-temp tests, DTA, TGA, detonation velocity tests and strand-burning tests as a function of total exposure. Table 4 lists the exposures and effects on some of the tests

Pb styphnate detonated within 2 minutes and a runaway reaction occurred with Tetryl after 2 hours. It was noted that an excess of 10^{16} n/cm² or 10^8 R gammas was required to produce a 10% weight loss in the more sensitive materials such as PETN and HMX. If one considers a 5% weight loss detrimental to the performance of components containing these expls, then doses above 10^{16} n/cm² and 10^8 R cannot be tolerated. Table 5 lists the weight-loss data obtained on the materials evaluated in these studies in terms of the dose required to give a 5% weight loss. A number of the exposures were performed at relatively high temps which might cloud the interpretation of this data

In this connection it is useful to show some of the curves on which the summary table is based. Fig 6 shows the weight loss for primary and booster expls and Fig 7 shows similar data for the main charge, or secondary expls

The effect of reactor irradiation on the expl temp can be seen in Fig 8 which is for TATB. One can easily evaluate the changes (decrease) in activation energy. By comparing the 5-sec expl temp, the peak DTA exotherm and the 10% weight loss values, one can see that the greater effect is on the 5-sec expl temp and hence the value of this determination as a criteria of sensitivity. The "10% loss on TGA" temp is another means by which one can show the effect of reactor irradiation on the thermal stability of the material

In utilizing nuclear reactors (or any radioactive source) for the irradiation of expls, proper precautions have to be taken to prevent any damage to occur to the reactor or source in the event of an expln. This led to the development of especially designed expln-proof irradiation capsules (Refs 63, 130, 156, 186, 192 & 194)

Mapes et al (Ref 135), in a joint program between PicArns and Brookhaven National Laboratory, irradiated small arms percussion primers in order to determine the suitability of such primers in devices to be used to scram a nuclear reactor

Four cal .30 percussion primers (the No 26 and No 72M production types and the X40 and X41 exptl types) were irradiated both by Co⁶⁰ gamma rays in the Brookhaven graphite reactor and were then tested for impact sensitivity. A large increase in impact sensitivity occurred, usually followed at 10^8 R or 10^{18} nvt with a 10^7 R gamma component by a drastic decrease. Reactor-irradiated production primers showed a second sensitization trend. The No 72M primers were considerably more radiation resistant than the No 26 at high dose but considerably less at low dose. The compns used in the primers are listed in Table 6.

Deterioration was visible in all irradiated primers as color changes in expl and brass parts, corrosion of brass, and cracking of expl layers. As exposure of the production types increased, weak detonations indicating some degradation were detected while impact sensitivity was still above standard; subsequent loss of charge occurred as sensitivity decreased, both effects being greatest in the No 26 primers

In 1972 the Boeing Company conducted an irradiation program to determine the feasibility of using a solid expl in a debris system in the Minuteman program (Refs 212 & 221). In theory the debris system consisted of a series of expl charges installed around the periphery of the Minuteman launch facility and initiated in the launch room. The purpose of the debris system was to remove crater ejecta from the silo abutment/closure interface and prevent debris from falling into the silo and interfering with a launch. It must survive a nuclear attack with the pertinent features being nuclear radiation, shock and fireball heating. The expls used in the test were PBXN-4 (DATB with nylon binder), HNS, and 94/6 TACOT/nylon. The neutron exposures were performed in the General Electric Test Reactor (GETR) at Vallicitos, California. The total doses were 1.7×10^{15} n/cm² fast, 5.6×10^{15} n/cm² thermal with 1.0×10^7 R. After irradiation, the expl samples

Table 5
Weight-Loss Summary (Ref 192)

Type & Material	Average Exposure Rates			Integrated Dose to Produce 5% Weight Loss			Maximum Exposure Temp (°C)	Remarks
	(Gamma) [ergs/gm(c)/hr] x 10 ¹⁰	Fast (> 1 MeV) n/cm ² /sec x 10 ¹⁰	Neutrons Thermal n/cm ² /sec x 10 ¹²	Gamma [ergs/cm(c)] x 10 ¹⁰	Fast (> 1 MeV) n/cm ² x 10 ¹⁶	Thermal n/cm ² x 10 ¹⁷		
Main Charge Expls								
TATB	3.4	7.5	8.32	27.0	21.4	23.9	163	-----
TACOT	3.4	7.5	8.32	25.7	20.4	22.7	133	Highest temp stability
DATB	3.4	7.5	8.32	20.6	16.4	18.3	150	-----
TNN	3.4	7.5	8.3	20.3	16.1	16.9	—	Estimate
TNN	5.4	12.7	14.5	7.4	6.2	7.2	234	High rate
ONT	3.4	7.5	8.3	16.0	12.7	14.1	—	Estimate
ONT	5.4	12.7	14.5	5.8	4.9	5.6	250	High rate
TNB	3.4	7.5	8.3	10.0	7.9	8.8	—	Estimate
TNB	5.4	12.7	14.5	3.7	3.1	3.5	~250	High rate
TNT	1.0	1.1	1.8	9.8	4.2	6.2	~ 60	Low rate; estimate
HMX**	3.7	8.0	7.1	1.0	2.6	2.9	~170	-----
Booster Expls								
ABH	3.8	7.5	8.3	15.0	11.9	13.3	183	-----
ABH	5.4	12.7	14.5	—	—	—	~300	Burned
HNAB	3.4	7.5	8.3	13.4	10.2	11.4	140	High rate; estimate
HNAB	5.4	12.7	14.5	4.6	3.9	4.5	~250	-----
HNS	3.4	7.5	8.3	12.0	9.5	11.4	140	-----
NONA	3.4	7.5	8.3	10.8	8.6	9.6	167	-----
NONA	5.4	12.7	14.5	4.2	3.5	4.0	~250	High rate
DIPAM	3.5	7.5	8.7	10.5	7.0	7.8	~160	-----
HNDS	3.4	7.5	8.3	4.6	3.7	4.1	160	-----
Tetryl	3.9	8.1	7.8	3.5	2.6	2.5	~180	Burned
PETN	3.7	7.4	6.7	0.96	0.6	0.67	~100	-----

R 21

continued

Table 5 (continued)

Type & Material	Average Exposure Rates			Integrated Dose to Produce 5% Weight Loss			Maximum Exposure Temp (°C)	Remarks	
	(Gamma) [ergs/gm(c)/hr] x 10 ¹⁰	Fast (> 1 MeV) n/cm ² /sec x 10 ¹⁰	Neutrons Thermal n/cm ² /sec x 10 ¹²	Gamma [ergs/cm(c)] x 10 ¹⁰	Fast (> 1 MeV) n/cm ² x 10 ¹⁶	Thermal n/cm ² x 10 ¹⁷			
Primary Expls									
KDNBF	3.8	7.5	8.3	10.2	8.1	9.0	174	-----	
Lead Styphnate	3.8	7.5	8.3	0.1	0.1	0.11	214+	Detonated	
NASA 2	3.2	7.5	9.0	0.17	0.14	0.16	~130	-----	
Igniters									
Black Powder	3.8	7.5	8.3	33.0	26.2	29.2	~100	Highest radiation stability	
ALCLO (Al/KClO ₄)	3.8	7.5	8.3	6.3	5.0	5.6	94	-----	
Propellants**									
IB7158	DATB/PSB	3.8	7.5	8.3	19.4	15.6	17.4	153	-----
PPLA 3223	DATB/VITON	3.8	7.5	8.3	8.1	6.4	7.1	151	-----
HES 6573	KClO ₄ /Acrylic	3.8	7.5	8.3	5.9	4.7	5.2	~100	-----
ANP 3095	AP/Al/PU	3.8	7.5	8.3	6.5	4.6	5.1	~100	-----
AK 14	KClO ₄ /PES	3.8	7.5	8.3	5.5	4.4	4.9	~120	-----
IB 7169	KClO ₄ /PS	3.8	7.5	8.3	4.9	3.9	4.3	~120	-----
M-6	NC/DNT	1.0	1.3	2.2	1.4	0.6	0.89	~ 60	Low rate
T-28	NC/NG	1.0	1.4	2.1	0.8	0.4	0.59	~ 70	Low rate; burned at high rate
T-36	NC/NG/NGU	1.0	1.3	2.2	0.6	0.3	0.44	~ 80	Low rate

R 22

* 95% HMX/5% EXON 461

** Definitions of propellant abbreviations:

PSB = Polystyrene-butadiene copolymer

PES = Polyester-styrene copolymer

NG = Nitroglycerine

AP = Ammonium perchlorate

PS = Polystyrene plasticizer with dioctylphthalate

NGU = Nitroguanidine

Al = Aluminum

PU = Polyurethane

NC = Nitrocellulose

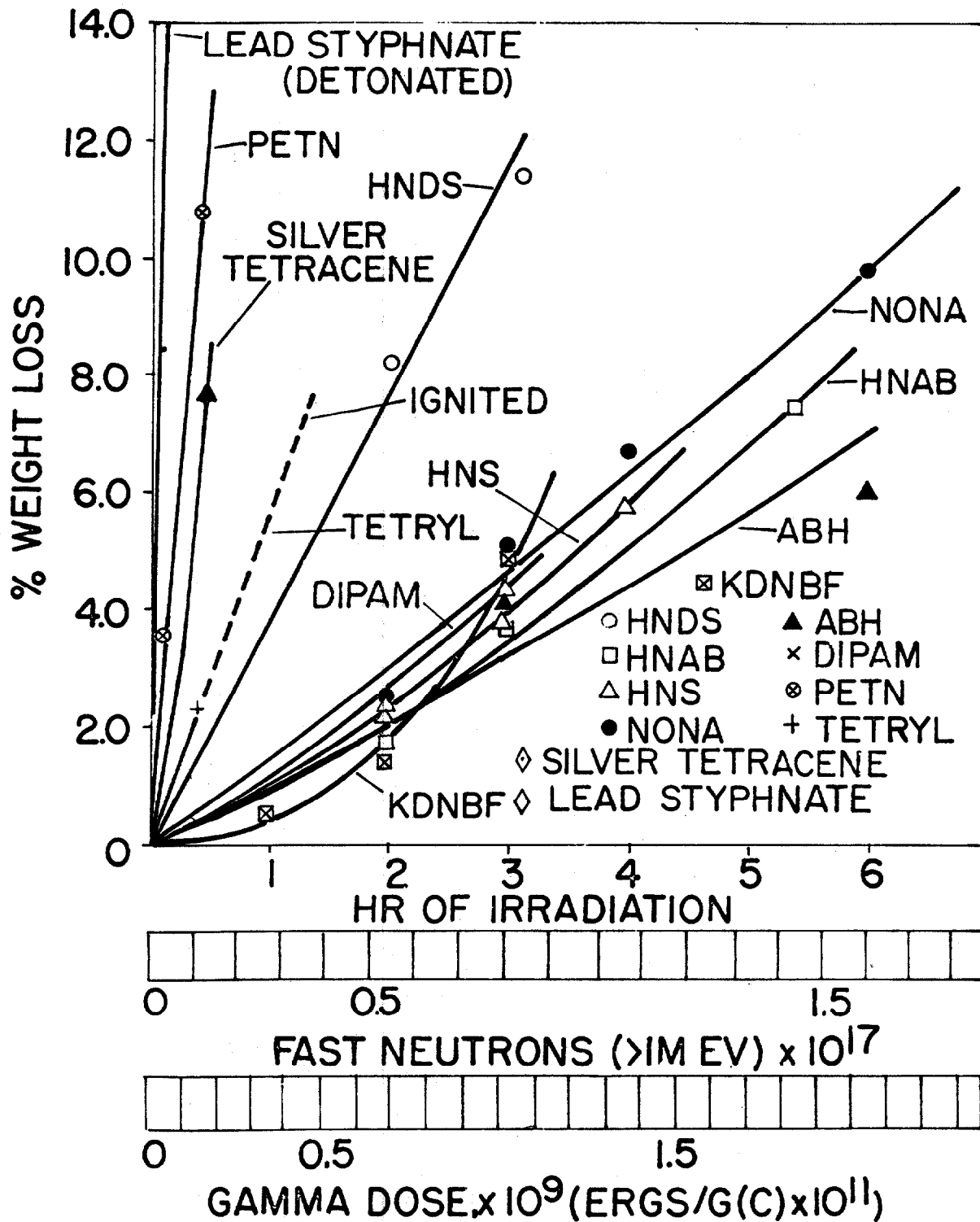

Fig 6 Weight Loss of Primary and Booster Explosives as a Function of Reactor Irradiation (Ref 192)

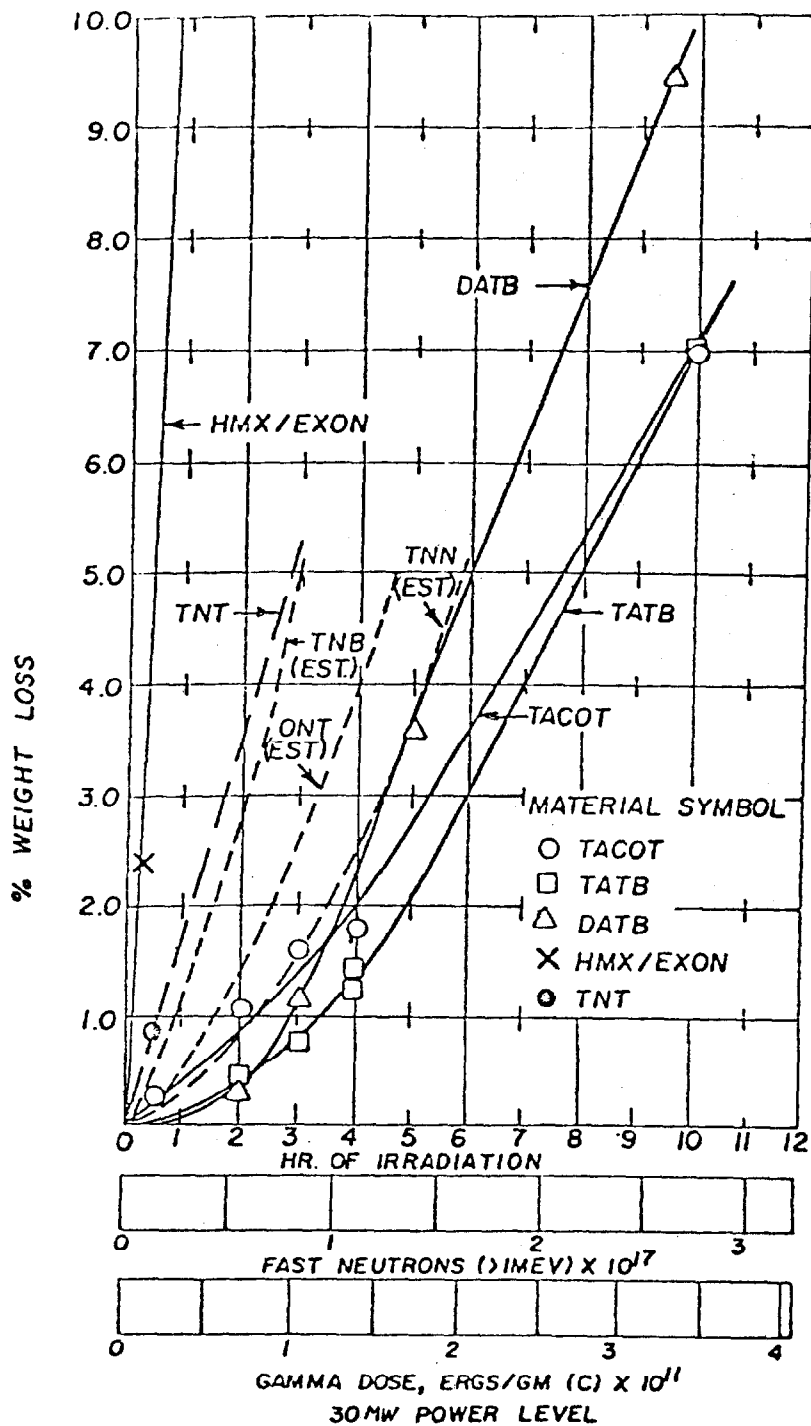

Fig 7 Weight Loss of Main-Charge Explosives as a Function of Reactor Irradiation – 30 MW Power Level (Ref 192)

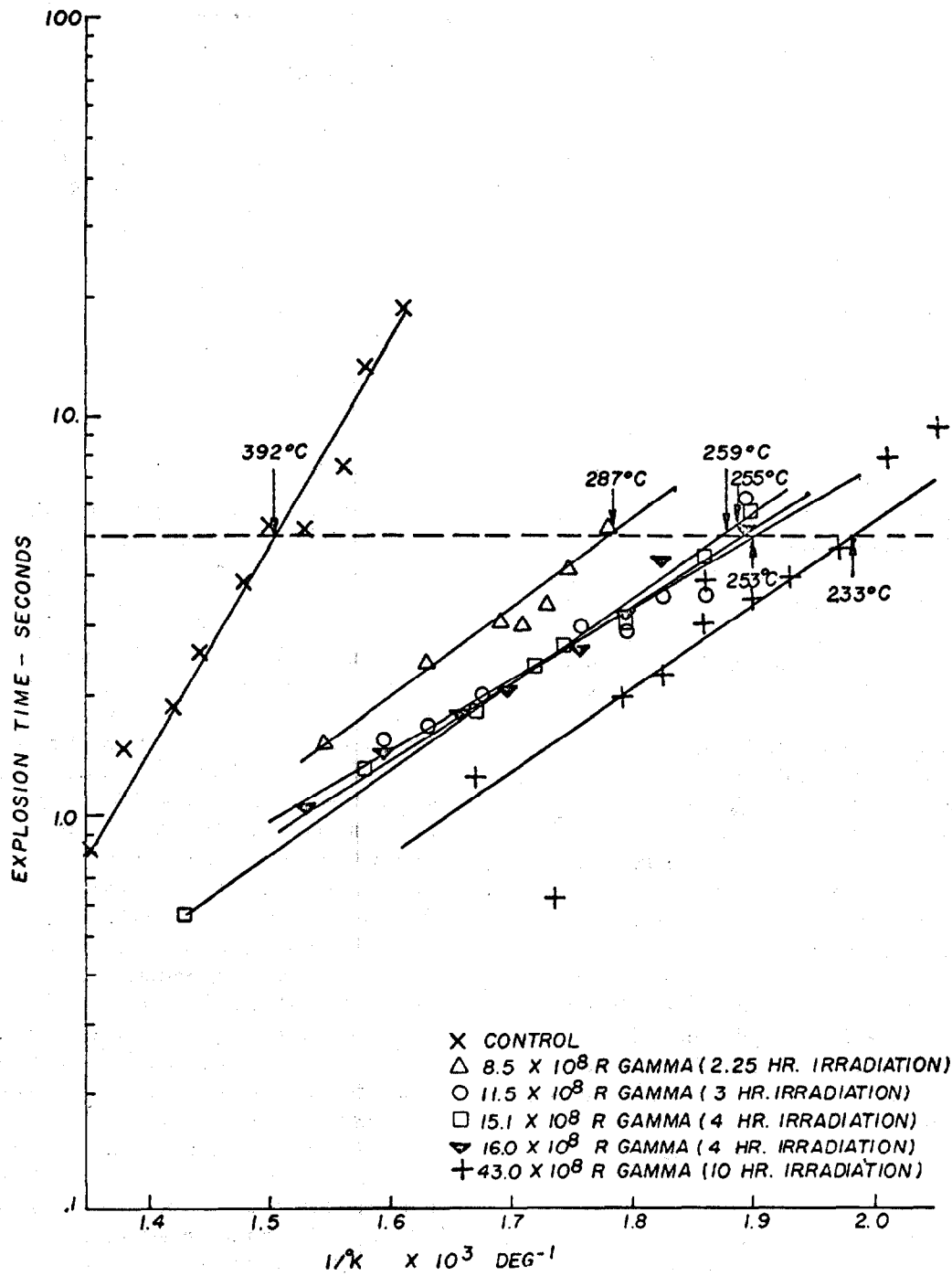

Fig 8 Effects of Reactor Irradiation on Explosion Temperature of TATB (Ref 192)

Table 6
Compositions Used in Caliber .30 Percussion Primers (Ref 135)

Composition	Primer Number			
	72M	26	X-40	X-41
Lead styphnate	38%	—	38%	37%
Barium nitrate	43.5	—	30	29
Lead dioxide	—	—	10	9
Antimony sulfide	9	17%	12	10
Tetrazene	2	—	3	3
Zirconium	—	—	7	7
PETN	—	—	—	5
Potassium chlorate	—	53	—	—
Lead thiocyanate	—	25	—	—
TNT	—	5	—	—
Calcium silicide	7.5	—	—	—

were heated to simulate the fireball heating and the following evaluation tests were performed: thermal sensitivity, shock sensitivity, propagation testing and a yield test. The expl yield of DATB decreased slightly, while the propagation sensitivity increased slightly after exposure. The changes were not considered significant to impair the system. DATB and HNS were recommended for use in the debris system

Menichelli (Ref 249) irradiated two types of EEDs with neutrons and gammas and tested after long term storage at elevated temps. One type of EED contained B/K perchlorate, Viton primer mix and an output charge consisting of Ti hydride/K perchlorate, while the second contained a Zr/K perchlorate primer mixt and a gunpowder output charge. The max neutron total dose was 2.5×10^{13} n/cm² and the max gamma dose was 2.5×10^5 R. The EEDs were stored up to 275 days at 120°. The first type revealed no major problems due to the irradiation or elevated temp. The second type with the gunpowder deteriorated to the point of failure

Pulsed Reactor Irradiation

One of the first instances where a very high dose rate might have unexpected effects on an expl was reported briefly by Urizar et al (Ref 98). Using the Los Alamos critical assembly known as Godiva II, the total dose delivered was about 7×10^{12} n/cm². The peak flux was estimated at 10^{17} n/cm²/sec since the pulse at half width was about 90µsec. The gamma dose was small — about 1200R~ due to self-shielding

The organic secondary expls were sealed in quartz containers and exposed to a single radiation pulse. None of the expls detonated and subsequent examination of the samples revealed negligible damage

Avrami and Voreck (Ref 192) reported on a transient radiation test in which a group of nine expls and proplnts in expln-proof irradiation capsules were subjected to a transient burst of energy of about 1 millisecond duration which resulted from fission of about 10^{21} atoms of U²³⁵. One set of nine capsules was attached to the KIWI reactor pressure vessel and another group on the support structure as part of the KIWI-B4-E excursion expt conducted by Los Alamos Scientific Laboratory at the Nevada Test Site. The materials selected were TATB, DATB and TACOT as the secondary expls, HNS as the booster expl, Pb styphnate as the primary expl, BlkPdr as the igniter, and three composite proplnts. Each capsule contained 3.6 grams of the selected material

The disruption and fragmentation of the reactor core as a result of the excursion hurled all the capsules from both locations at least 500 feet away. The Pb styphnate sample which had been mounted on the pressure vessel showed evidence of a high-order detonation, which was assumed to be the result of the high rate of energy input from the KIWI-TNT test. This assumption was based upon several premises. Primarily, the possibility of the material detonating as a result of impact rather than by radiation did not seem reasonable, since the other sample

bolted onto the support structure also received sufficient blast and impact to hurl it about 500 feet away, but with negligible effect. Although all but one of the capsules located on the pressure vessel and all of those on the support structure were found, this sample was the only one that may have been subjected to, or gave any indications that, a high-order reaction had occurred. The pressure vessel samples were a little over 26 inches away radially from the center of the reactor core, while the support structure samples were about 59 inches away. The fluxes and dosages are shown in Table 4. The thermal neutron flux rate was about 10^{18} n/cm²/sec

Although Pb styphnate was the material most impact-sensitive in the KIWI-TNT test, the fact that the second sample on the support structure survived the excursion raised doubt that the detonation was caused by blast or impact. Further evidence supporting this view was obtained when a 1.8 gram sample of Pb styphnate detonated after only two minutes of irradiation in a steady-state nuclear reactor (GETR)

As shown in Table 4 some changes were noted from the transient pulse. The mp was lowered from 216 to 208° and the 5-sec expln temp also was lowered from 299 to 268°. None of the other materials tested showed any evidence of any gross radiation damage or of burning, and subsequent tests confirmed this

Studies on the effect of pulsed nuclear reactor irradiation were conducted on RD-1333 Pb azide (Ref 254). Bulk samples of RD-1333 were exposed to a total dose of 2.0×10^{14} n/cm² from an unmoderated, unreflected, prompt pulsed reactor in a pulse 40 to 50 μsec full-width at half-maximum. Analyses of the Pb azide which included the vacuum stability test, expln temp test, and the detonation velocity test, did not show any changes due to the transient radiation environment

An interesting series of expts were conducted by Kurowski, Hartman and Gover (Ref 219) where mixts of RD-1333 Pb azide and fine particle B actually were detonated in the neutron environment produced at the Sandia Laboratories water-moderated Annular Core Pulsed Reactor (ACPR). The average particle size of the B was 363 Å with the range from 150–900 Å. The mixts were by weight and pressed into .010" thick Al cups, 0.150" in diameter

The absorption of thermal neutrons in B produces alpha particles according to the following interaction:

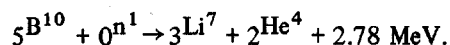

The Li ion and alpha particle are stopped in the Pb azide/B mixt, thereby converting their kinetic energy of 2.78 MeV to the thermal energy of the system. The results are listed in Table 7. The pulse width during the tests was 4.7 milliseconds (FWHM) so that the max thermal neutron dose rate was about 3.6×10^{17} n/cm²/sec. The average gamma dose was 1.14 x 10⁶ R (10⁶ rads)

A homogeneous model of this system which assumes that the mean temp rise of the mixt must be 350° in order for detonation to occur predicts the following detonation thresholds:

Thermal neutron fluences (nvt)	PbN ₆ /B ratios
1.95×10^{13}	0
5×10^{13}	3.24
10^{14}	8.56
5×10^{14}	51
10^{15}	104

Therefore, detonation of the 100:1 specimens at 0.5×10^{15} nvt thermal would not be expected by this model while the remaining results are consistent with the model's predictions. These results then suggest that at the higher fluences detonation results from hot spots ($T > 350^\circ$) within the expl while lower fluence results are in agreement with the homogeneous thermal model

In order to obtain a higher total neutron dose in a pulsed environment, expts were conducted by Avrami et al (Ref 247) to irradiate electro-explosive devices in the "glory hole" of the APRFR. The EED was mounted in an irradiation capsule and positioned in the glory hole. The max exposure level attained was 4.7×10^{14} n/cm² of near-fission fast neutrons delivered in a single 80 μsec wide reactor pulse. The gamma component was about 1.4×10^5 R gamma. This corresponds to a peak flux of 5×10^{18} n/cm²/sec or 1.5 calories/gm with a gamma rate of 1.4×10^9 R/sec. The D3A2 detonator consists of Pb styphnate, Pb azide, and PETN. The EEDs were fired 50 μsec after irradiation and checked by comparing firing times and plate dent results.

Table 7
Pulsed Reactor Irradiation of Lead Azide/Boron Mixtures (Refs 219 & 257)

Ratio Lead azide/Boron	Density (g/ml)	Neutron environment	Result
100:1	2.0	1.5 x 10 ¹⁵ nvt, E > 10 KeV 0.5 x 10 ¹⁵ nvt, thermal	Detonation
	2.5		Detonation
	3.0		Detonation
	3.5		Detonation
50:1	2.0	3.5 x 10 ¹⁴ nvt, E > 10 KeV 1.2 x 10 ¹⁴ nvt, thermal	No detonation
	2.5		No detonation
	3.0		No detonation
	3.5		No detonation
	2.0	3.0 x 10 ¹⁴ nvt, E > 10 KeV 1.0 x 10 ¹⁴ nvt, thermal	No detonation
	2.5		No detonation
	2.0	9.0 x 10 ¹⁴ nvt, E > 10 KeV 3.0 x 10 ¹⁴ nvt, thermal	Detonation
10:1	2.5		Detonation
	3.0	3.0 x 10 ¹⁴ nvt, E > 10 KeV 1.0 x 10 ¹⁴ nvt, thermal	No detonation
	3.5		No detonation
	3.0	9.0 x 10 ¹⁴ nvt, E > 10 KeV 3.0 x 10 ¹⁴ nvt, thermal	Detonation
	3.5		Detonation

The results indicate that such devices can be irradiated with 80 μ sec wide pulses to radiation levels about an order of magnitude higher than previously possible in out-of-core expts

c) Gamma Irradiation of Explosives

The primary interaction of gamma rays with matter is the production of ionization or excitation. The three processes of interaction are: the photoelectric effect, the Compton effect, and pair production. The predominance of each of these effects is determined by the energy of the gamma ray and the atomic number, Z , of the absorber. The photoelectric effect is favored for low energies, the Compton effect for intermediate energies, and pair production for high energies

In nuclear weapons effects studies the fission spectrum anticipated and the materials considered are such that the photoelectric and Compton effects are the most important. In both of these effects electrons are ejected with energies comparable to the energy of the inci-

dent gamma rays. The electrons are then capable of producing displacements, but the number of displacements is negligible when compared to the number produced by neutron bombardment. The photoelectric and Compton effects can result in the temporary liberation of free charge or the acceleration of electrons over potential barriers

Steady-State Gamma Irradiation

Stead-state γ -irradiation of any expl has not been known to initiate a detonation. The effect of such irradiation appears to result in slow decompn with a deterioration in the functional properties of the expl, or more generally, energetic materials

One of the first investigations to study the effect of gamma rays on expls was conducted in 1948 by the Los Alamos Scientific Laboratory and the Oak Ridge National Laboratory as reported by Noyes and Goodman (Refs 21 & 23). In this preliminary study 5g samples of RDX, Tetryl, TNT and Composition B were placed for 10 days in a nest of activated uranium slugs for a total gamma dose of 8.6×10^6 R. The rela-

tively low intensity of the radiation produced no visible changes, the gas evolution was slight, and the mp changes were negligible. Goodman also reported the electron bombardment of Ba nitrate and questioned the applicability of that expt to gamma and fast neutron irradiations. However, the statement was made that the results were more indicative of the effects of gammas than of neutrons

A rather extensive program on the effect of gamma radiation on expls was carried out by PicArns and the Oak Ridge National Laboratory (Refs 26 & 37). Using 0.41 MeV ^{198}Au γ -rays, a group of expls were irradiated at three different temps (70° , ambient, and -40°) to determine the relative effect on the vacuum thermal stability test. The volumes of gas produced were measured during and after irradiation. The amount of gas evolved as a function of gamma dose for each of the expls irradiated is shown in Fig 9. Fig 10 shows the effect of temp at the time of irradiation for dextrinated Pb azide. The total gamma dose that the dextrinated Pb azide received was 5.77×10^7 R

A continued evolution of gas from Pb azide after the radiation source had been removed suggested that either gas was trapped in the sample during irradiation or that decompn continued after irradiation (Ref 121). When samples were irradiated at 71° and cooled, no such gassing occurred. In all cases more gas was evolved than could have resulted from heat alone

The work by Warren et al (Refs 26 & 37) was the first comprehensive program in determining the effects of gamma radiation on a variety of expl materials including primers and detonators. A series of tests were performed on the irradiated materials and the results are listed in Table 8. Kaufman

(Refs 51, 53 & 58) reviewed the data of Warren et al (Ref 37) and observed that a few nonrigid generalizations could be made. Although the materials can be ordered relative to decompn, a variation in kinetics as shown by the calcns for the activation energies and temp coefficients of evaluation as follows:

Material	Activation energy, kcal/mole	Temp coeff of gas evolution ml/g/ $^\circ\text{C}$ (S.T.P.)
Lead styphnate	1.8	8.55×10^{-5}
TNT	2.8	1.46×10^{-4}
Tetryl	6.5	5.18×10^{-4}
Lead azide	7.5	5.8×10^{-2}

These activation energies resemble those found by Thomas and Tompkins (Ref 27) for the photolytic decompn of similar materials, and Kaufman suggested similar behavior despite the varied chemical constitution represented. The data in Table 8 also indicates that large gas evolution is not entirely related to a decrease in explosiveness. It can be seen that while DDNP and MF gassed excessively and showed reduced ability to crush sand after irradiation, dextrinated Pb azide and RDX also evolved a large amount of gas but did not show impairment of sand values (actually MF could only be initiated with Pb azide in the sand test after a gamma dose of 2.97×10^7 R; with a BlkPdr fuze it would only burn). The last generalization made was that the lower limit at which decompn could be detected was about 10^6 R

The results on the irradiated M26 primers and M19A2 detonators are shown in Fig 11. The primer charge contained only 5% Pb azide while the detonator contained the same primary charge plus 250mg Pb azide and 142mg Tetryl. It was determined that with a total gamma dose of 9.7×10^7 R (90 day exposure), 92% failures were obtained in the stab tests on a sample of 100. The failures were attributed to the deterioration of the Pb azide (the Pb azide did initiate but failed to initiate the Tetryl charge)

Kaufman (Ref 51) stated that Pb styphnate was the most gamma-radiation-resistant expl in the Oak Ridge studies and this was confirmed by Flanagan (Refs 61 & 94) who irradiated Pb styphnate monohydrate with Co^{60} gammas (~ 1.25 MeV) up to 1.8×10^7 R without significantly altering the subsequent thermal decompn curves. However, as seen above, this was not the case with reactor irradiation of this material

A dose of 10^6 R Co^{60} gamma rays reduced the diamagnetic susceptibility of α -Pb azide more than threefold (Ref 41). Colloidal Pb

Table 8
Summary of Data Obtained From Explosives After Exposure to γ -Radiation (Ref 58)

	<u>TNT</u>	<u>Tetryl</u>	<u>RDX</u>	<u>Lead Azide</u>	<u>Lead Styphnate</u>	<u>Mercury Fulminate</u>	<u>Diazo-dinitro-phenol</u>	<u>Nitro-glycerin</u>	<u>PETN</u>
Weight of sample (g)	5	5	5	2	5	5	2	1.0	5.0
Volume of gas produced (ml/g) in the following times (days)									
10	0.02	0.10	0.16	0.05	0.17	0.25	2.5	0.10	
20	0.04	0.20	0.44	1.95	0.07	0.57	1.35	5.0	0.43
30	0.06	0.35	0.87	2.90	0.09	2.96†	3.25	7.5	1.04
40	0.08	0.48	1.49	3.95	—	—	5.60	9.0	2.33
50	0.11	0.66	—	5.30	0.10	—	7.2	10.8	—
90	0.20	1.40	—	—	0.12	—	—	—	—
Total irradiation time (days)	90	90	44	52	90	29	45	56	42
Purity of sample, by chemical analysis (%)									
original material	—	—	—	93.08	—	97.5	—	—	—
irradiated material	—	—	—	89.04	—	65.5	—	—	—
Melting points, corrected (°C)									
original material	82.1	128.8	204.8	—	—	—	—	—	140.8
irradiated material	80.9	127.8	204.8	—	—	—	—	—	137.0
Sensitivity to impact, PicArsn machine (in)‡									
original material	13	—	9	3	6	—	2	—	—
irradiated material	12	—	8	3	6	—	2	—	—
Sensitivity to impact, Bureau of Mines machine (cm)‡									
original material	95	25	40	65	20	7	4	—	—
irradiated material	95	26	25	75	22	5§	3	—	—
Sand test, 200g bomb, grams of sand crushed when sample was ignited by BlkPdr fuse only									
original material	—	—	—	20.5	14.1	21.5	22.1	—	—
irradiated material	—	—	—	18.7	14.3	0.0§	14.1 ± 6.9	—	—
Sand test, 200g bomb, grams of sand crushed when sample was initiated by 0.30g of Pb azide									
original material	48.9	56.4	61.7	—	—	25.7	—	—	—
irradiated material	50.1	56.0	62.0	—	—	13.1§	—	—	—

† Volume of gas evolved from sample in 29 days

‡ Minimum height of fall of 2.0kg weight to produce at least one explosion in ten trials

§ Sensitivity-to-impact tests and sand tests were performed 35 days *after* chemical analysis

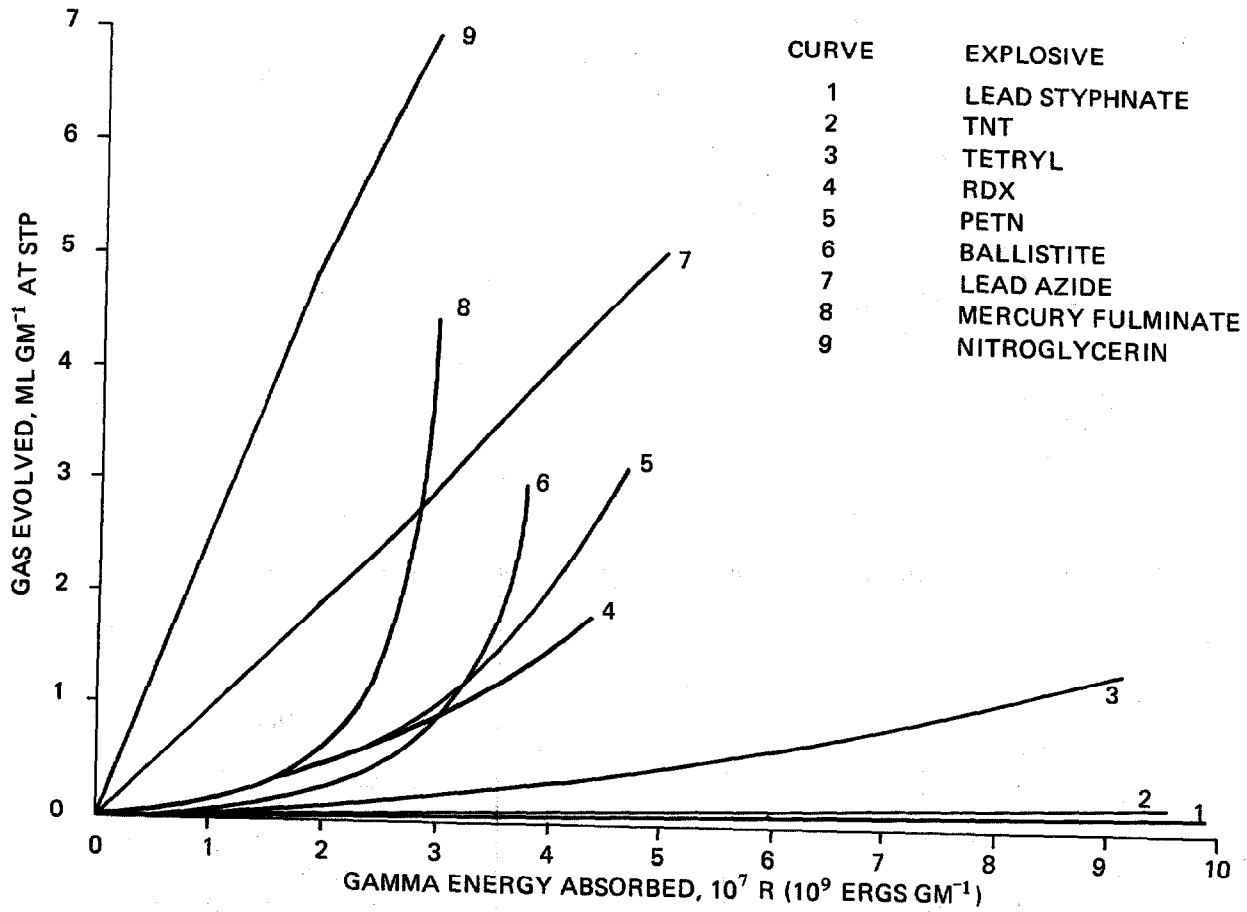

Fig 9 Gas Evolution by Gamma-Irradiated Explosives at Ambient Temperature (Ref 37)

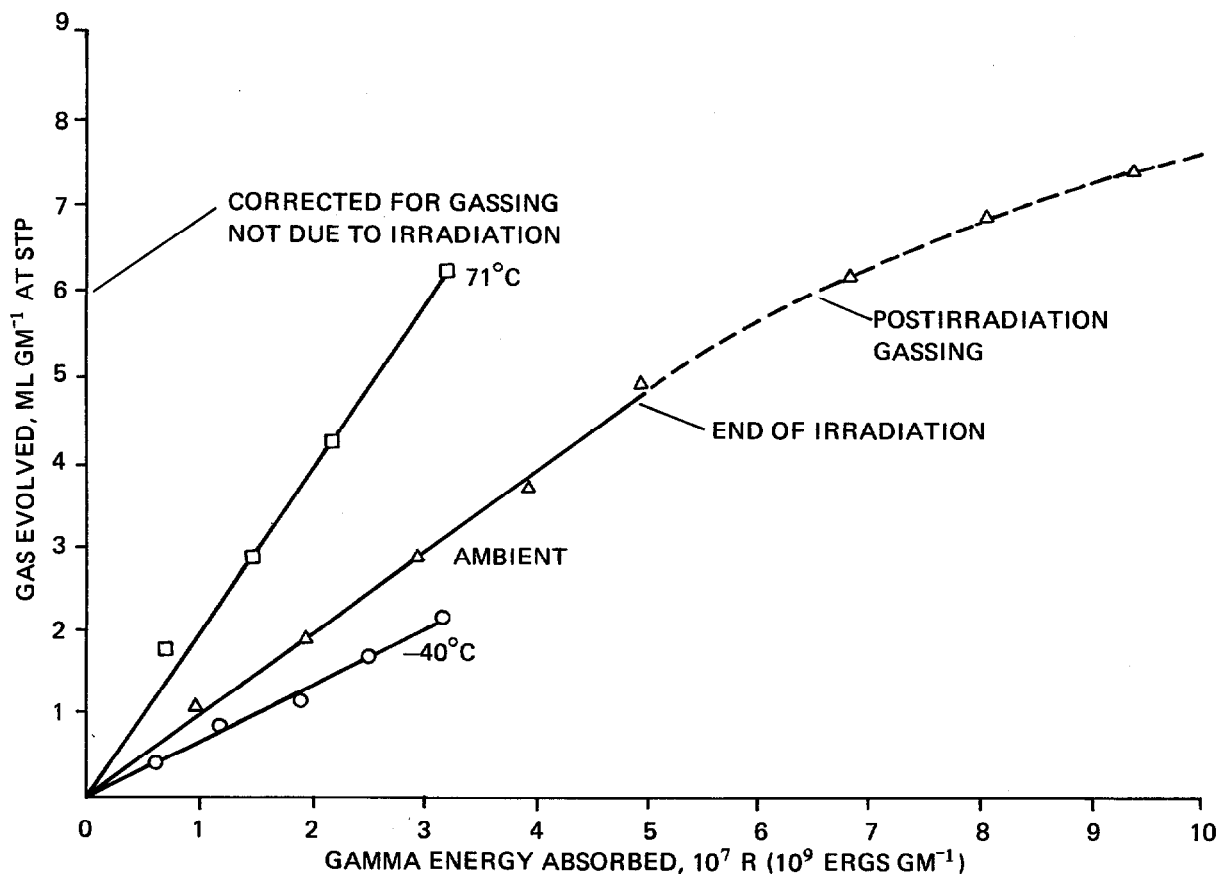

Fig 10 Gas Evolution by Irradiated Dextrination Lead Azide at Different Temperatures (Ref 37)

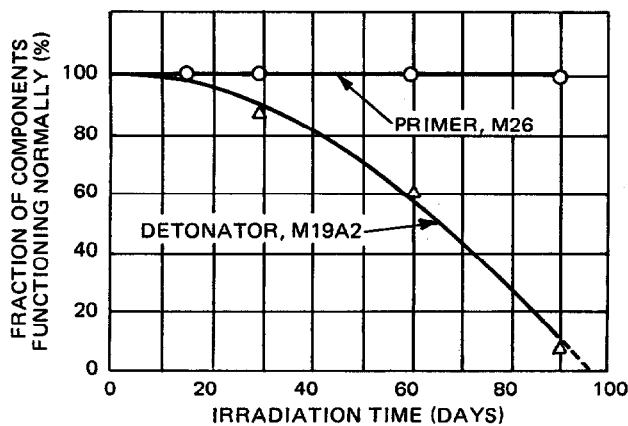

Fig 11 Apparent radiation damage to standard loaded components after irradiation with 0.41-MeV gamma at 10⁵ R/hr (Ref 51)

azide, irradiated with a Co⁶⁰ gamma source with exposures of 2.5, 7.5, and 22.5 x 10⁷ R, had its impact sensitivity increased from 12 to 6 inches with the PicArasn impact test (Refs 49 & 63)

In the gamma irradiation of pellets of Composition 9404, a NC-bonded HMX, a weight loss of 8% and an expansion of 2.9% were recorded for a total dose of 2.5 x 10⁸ R. Mapes et al (Ref 75) also reported that exposure of HMX to gamma rays increases its impact sensitivity

Mapes et al (Refs 83, 151 & 152) continued their studies on the effect of gamma Co⁶⁰ radiation on ten plastic-bonded HMX and DATB comps. Exposures up to 3.5 x 10⁸ R at three rates, 4.3 x 10⁴, 2.1 x 10⁵ and 7.4 x 10⁶ R/hr, were obtained. Physical changes were determined by measurements of diameter, length and weight and by calcs of volume and density. DATB/EXON displayed the most resistance to dimensional and weight changes. DATB/EXON had practically no changes while HMX/NC at

4×10^8 R had a 16% weight loss. Unpublished results by Mapes showed corresponding effects on the detonation velocity tests

Threshold criteria were being considered as an effect of the irradiations. Among the many proposed, Fink (Ref 90) set forth for expls a threshold range of $1 \times 10^9 - 1 \times 10^{11}$ erg/gm(C) ($1.14 \times 10^7 - 1.14 \times 10^9$ R) with the threshold criteria of a 10% decrease in expl force power. The time factor was not included as with Grocock (Ref 59) who calcd that 3.42×10^7 R in one second would ignite HMX

The radiation-induced color changes in inorganic materials (Ref 145) led to a comprehensive study by Rosenwasser, Dreyfus and Levy (Ref 148) on Na azide, which turns to brownish yellow when subjected to radiation. Subsequently, when mechanically deformed crystals of Na and K azide were irradiated with 10^7 R gamma radiation, Dreyfus and Levy (Ref 69) observed the formation of pyramidal etch pits which occurred mainly in regions where imperfections were located at the surface. These were also evident in ammonium perchlorate crystals (Ref 255)

Thermal decompn studies on Ba and Sr azides pre-irradiated with ~ 1 MeV gamma rays were conducted by Prout and Moore (Refs 131 & 149). With dehydrated Ba azide a total gamma dose of 20 Mrads (2.24×10^6 R) practically eliminated the induction period and increased the acceleration of the decompn. The same effect was evidenced with Sr azide but the sensitivity of Sr azide to gamma rays exceeds that of Ba azide and other materials

Piantanida and Piazzzi (Ref 100) irradiated Picric Acid, TNT, PETN, PETN/wax and RDX in a Co^{60} source. Samples were irradiated to two levels, 5×10^6 and 20×10^6 R, and the chemical stability was checked by Taliani's method - by maintaining the sample at 120° , by measuring the pressure of the decompn products, and by expressing the number of minutes required to reach a pressure of 300mm Hg. PETN/paraffin wax in pellet form was the most radiation-resistant by Taliani's method

Loughran (Ref 127) continued studies on HMX (Ref 98), both in the reactor and gamma environments, determining gas evolution, trapped gas, and changes in thermal characteristics.

Studies were also conducted on RDX and HNB. Impact studies on β -HMX indicate that with Type 12B tools gamma radiation from $17-13 \times 10^6$ rads decreases somewhat the impact sensitivity of HMX

In 1963 Berberet (Ref 121) surveyed the field of radiation effects in expl solids, and calcd (Ref 123) the temp rise as well as the production of atomic displacement by various heavy atomic particles, including gamma rays. In a series of expts for the Air Force (Refs 140, 141 & 172), Berberet irradiated a group of expls in pellet form - two heterocyclic compds, HMX and RDX; four conventional compds, TNT, DATB, TNB and Tetryl; and four fluoro-derivatives, TNTF, DFTNB, MFTNB and TFET. Dimensional stability, chemical decompn, density and electrical resistivity were measured before and after irradiation in a Co^{60} source. Also studied were the thermal properties, stored energy states and free radical formation. Radiations made at liq nitrogen temp showed that many short-lived effects were produced by the irradiation. Samples were irradiated to levels of 1.2×10^9 R with rates of 10^7 R/hr. With the exception of TNT, the density of all the materials decreased monotonically with increasing dose. HMX and RDX pellets crumbled at fairly low doses

Avrami, Jackson and Kirshenbaum (Ref 205) studied the same materials as Berberet (Ref 165) in powder and pellet form. The dose rates were from 6.4 to 9.2×10^5 R/hr while the total exposures ranged from 10^7 to over 10^9 R. Besides weight loss, dimensional changes and vacuum stability tests, also checked were melting points, IR, impact sensitivity tests, expln temp tests and detonation velocity tests. MFTNB and DFTNB were the best radiation-resistant materials to levels above 10^8 R. RDX, HMX and the remainder of the materials degraded appreciably at the 10^8 R level

Castorina et al (Refs 164 & 180) studied the surface activity of one-micron size α -HMX as a function of Co^{60} gamma dose in vacuo and vapors of H_2O , NO and NO_2 . The production of polar surface adducts suggests that the mechanism of energy transfer from the bulk of the substrate to the surface-vapor phase interface be postulated to apply to crystalline organic substrates. By this mechanism changes in surface properties can be achieved without any serious

Table 9
Effect of Co⁶⁰ Gamma Radiation on Explosives by PicArsn Impact Sensitivity Test(Inches) (Ref 223)

Explosive	Total Gamma Dose, R			
	0	1.4x10 ⁷	1.2x10 ⁸	1.0x10 ⁹
DATB	20.6*	19.0*	17.8*	13.5*
HMX	14.0	11.0	9.0	10.0
NGu	27.8	20.7	24.8	36+
PETN	9.2	7.7	7.6	—
RDX	14.7	14.3	11.5	—
TACOT	12.0	12.5	12.3	11.8
TATB	22.2	17.6	18.4	17.1
Tetryl	17.3	16.2	19.5	18.2
TNB	23.3	18.5	20.5	32.5
TNT	25.5	26.5	—	30.1

Rate = 6.4 – 9.2 x 10⁵ R/Hr

* Burned, no explosion

perturbation of the molecules in bulk

A group of eleven expl materials in powder and pellet form were subjected to Co⁶⁰ gamma radiation by Avrami, Jackson and Kirshenbaum (Ref 223). The expls were studied using weight loss, dimensional changes, vacuum stability, DTA, TGA, IR, melting point, impact sensitivity, expln temp, and rates of detonation as a function of total gamma exposure up to and including levels of 10⁹ R. Based on this work, a damage threshold as a function of total gamma dose was determined for each material: a) RDX, PETN and NGu can withstand gamma radiation to a level of 1.0 x 10⁷ R; b) HMX, Tetryl, TNB, and TNT to a level of 1.0 x 10⁸ R; c) TACOT, TATB and DATB to a level of 1.0 x 10⁹ R; and d) BaN₆ was not able to withstand a level of 1.4 x 10⁷ R

Fig 12 depicts the weight loss of the expls in pellet form as a function of gamma dose. Table 9 shows the impact results. Table 10 lists the detonation velocity data which is graphically shown in Fig 13

Long-term low-level gamma radiation on HMX, RDX, HMX/RDX mixts and Comp B (225 R/hr for 60, 90 and 120 days) did not adversely affect the thermal stability and sensitivity of the materials studied (Ref 253)

Avrami, Jackson and Kirshenbaum subjected Ba azide to Co⁶⁰ gamma radiation to exposure levels up to 1 x 10⁹ R (Ref 223). The effect of gamma radiation on Ba azide can be seen in the DTA thermogram in Fig 14. In the thermogram the larger exotherm practically disappeared and may have been only a residue. Actually the IR spectra indicated that the material was decompd and subsequently reformed into a form of Ba carbonate. This is not surprising since the BaN₆ was irradiated in air at room temp for approx 10⁴ hours. Impact tests were erratic but the 1 x 10⁹ R sample did not explode at 36 inches

Three types of Pb azide plus thallos azide were subjected to long-term exposures of Co⁶⁰ gamma radiation by Avrami, Jackson and Wiegand (Refs 254, 257). Some of the Pb azide results are listed in Table 11. Each type of Pb azide was irradiated in powder and pellet form and in each case the weight loss was greater in the powder form. All the pellets subjected to a total gamma dose of 1.16 x 10⁹ R were too soft to measure. In the PA impact test no fires were obtained at the max height of 36" for dextrinated Pb azide at the higher exposure. A curious result was made evident in testing the other Pb azides. Using the Pb azide originally irradiated in pellet form, a greater decrease in impact sensitivity was obtained

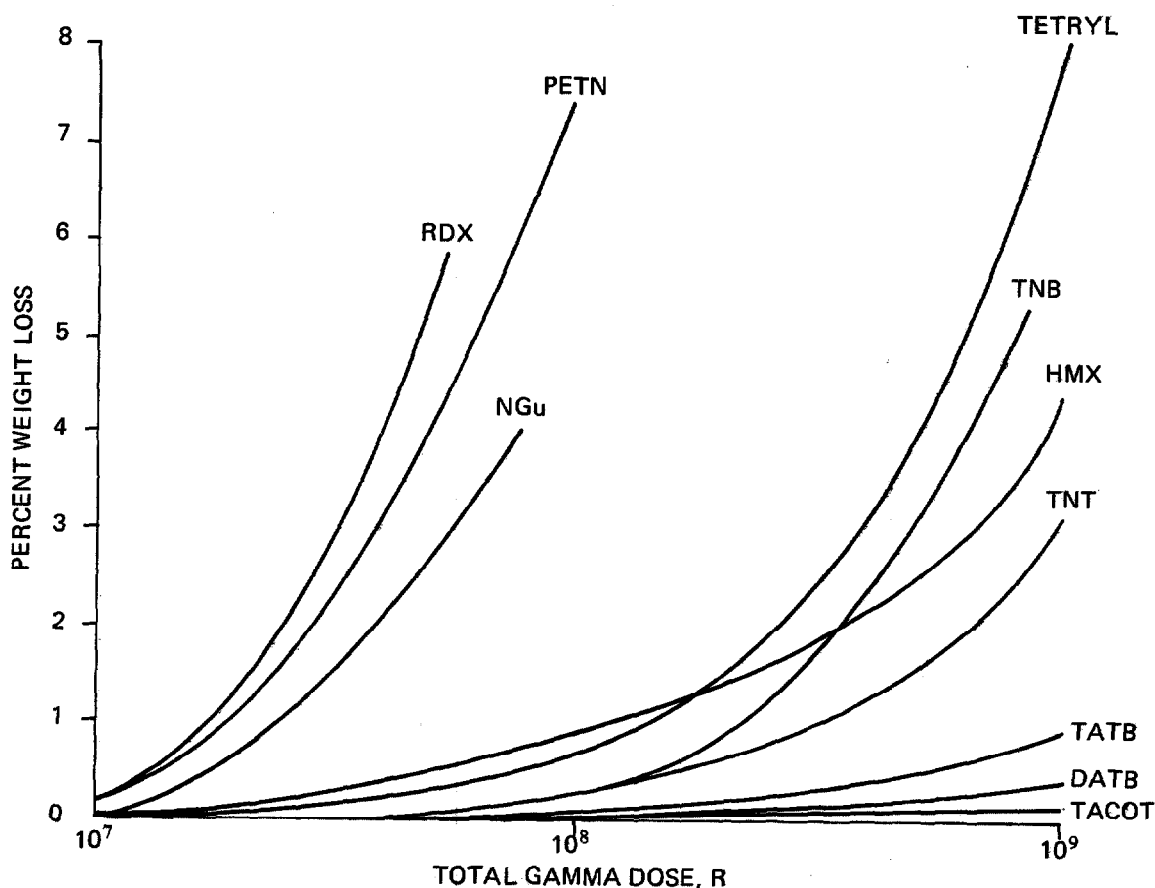

Fig 12 Weight Loss of Co⁶⁰ Irradiated Pellets (Ref 223)

for RD-1333 and PVA Pb azide than the irradiated bulk samples of each type

The DTA thermograms indicate for each type a shifting downwards of the exotherm at the 1.0×10^8 R level. The IR spectra for the various Pb azides reveal that a form of Pb carbonate is evident at the higher exposure. This is probably the reason for the lower values in the vacuum stability test listed in Table 11. Another interesting feature was the formation of ammonium nitrate on top of each Pb azide and thallos azide irradiation capsule (as shown in Fig 16) subjected to over 10^9 R

The thallos azide was subjected to an exposure 5.4×10^9 R and was reduced to a form of thallos oxide according to IR spectra

Pulsed Gamma

The effects of high gamma dose rates usually are simulated with a flash X-ray unit that generates a Brehmstrolung spectrum with a pulse with around 30 nanoseconds

Work in this area has not been very extensive. This is probably due to the low gamma component that has been measured or calcd for a nuclear burst. Also the accumulated effect from a pulsed reactor burst simulates a weapon effect more so than a burst of gamma rays. The possibility of generating IEMP or an electric field when irradiating expl-loaded components cannot be discounted (Ref 232 & 233)

Table 10
The Effect of Gamma Radiation on the Rates of Detonation for Explosives (Ref 223)

Explosive	Control		Total Exposure (R)									
	Density (g/cc)	Rate of Det (m/sec)	1 x 10 ⁷			1 x 10 ⁸			1 x 10 ⁹			
			Density Before (g/cc)	Density After (g/cc)	Rate of Det (m/sec)	Density Before (g/cc)	Density After (g/cc)	Rate of Det (m/sec)	Density Before (g/cc)	Density After (g/cc)	Rate of Det (m/sec)	
DATB	1.49	6630	—	—	—	—	—	—	—	—	—	—
	1.80*	7600	1.66	1.66	7185	1.66	1.65	7180	1.71	1.70	7235	
HMX	1.75	8620	1.75	1.75	8620	1.74	1.66	8410	—	—	—	
PETN	1.67	8045	1.68	1.67	8035	1.66	1.54	7660	—	—	—	
RDX	1.69	8380	1.70	1.68	8360	1.70	—	6935	—	—	—	
TACOT	1.58	6935	1.57	1.57	6915	1.56	1.56	6910	1.38	1.38	6285	
TATB	1.84	7510	1.84	1.84	7520	1.85	1.84	7525	1.82	1.81	7435	
Tetryl	1.69	7540	1.69	1.69	7515	1.65	1.62	7400	1.62	1.47	7010	
TNT	1.60	6875	1.60	1.60	6875	1.59	1.55	6850	1.57	1.45	6395	
TNB	1.65	7150	—	1.63	7115	—	—	—	—	—	—	

* NOLTR 65-218

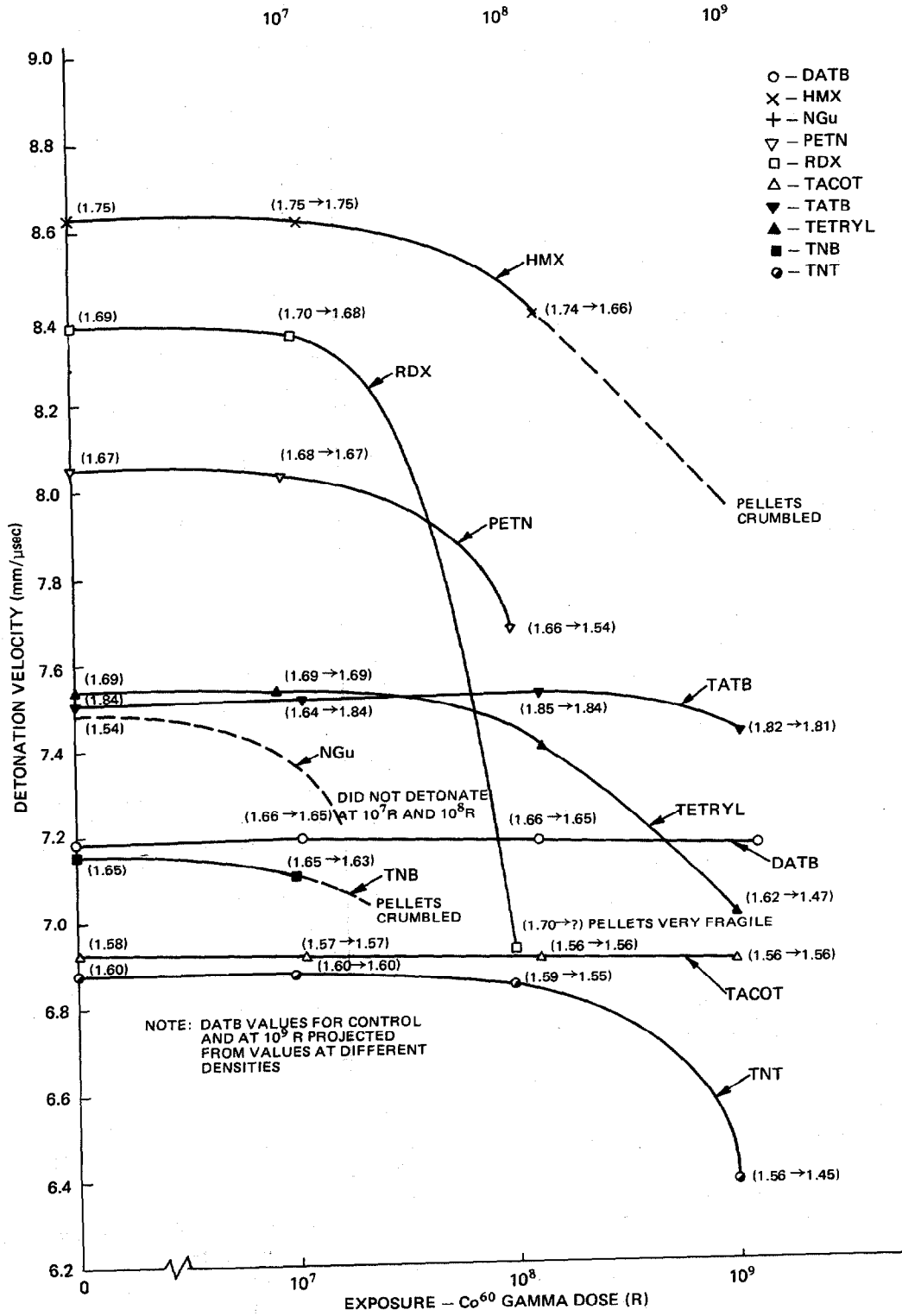

Fig 13 Effect of Gamma Radiation on the Detonation Velocity of Explosives (Ref 223)

d) Underground Testing (UGT) of Explosives and Explosive Devices

A nuclear detonation can be expected to produce a neutron, gamma and X-ray environment within the system involved. This environment is a function of burst altitude, slant range to the burst point, radiation output, and spectra of the weapon. Nuclear environments are categorized according to whether the burst is exoatmospheric (above the atmosphere, actually above about 100km) or endoatmospheric (within the atmosphere, or below about 100km). Nuclear radiations (X-rays, neutrons, gamma rays, charged particles) are common to all nuclear-weapon-produced environments; other effects such as blast, thermal radiation, and electromagnetic pulse depend upon the surrounding atmosphere and hence upon the altitude of the burst

Under exoatmospheric conditions the neutrons, gammas and X-rays emitted directly from a nuclear weapon are attenuated by inverse square spherical divergence. Within the atmosphere the attenuation process is more complex. The radiation pulse emitted by the weapon is attenuated thru scattering and absorption by the surrounding air as well as by inverse square spherical divergence. In addition the neutron absorption by nitrogen in the air generates a large number of gammas which contribute to the total nuclear environment. The most significant gamma component is the prompt gamma pulse, which results from the weapon itself, and from the gammas produced by absorption of the early neutrons by the weapon case materials

Radiation effects are generally classified as permanent or transient. Permanent damage involves the irrevocable alteration of a component or subsystem, preventing the main system from functioning properly in its intended mission. A transient effect can be defined as a radiation-induced perturbation of short enough duration, so that system recovery may be possible after a short relaxation time. Neutrons tend to produce permanent damage, while gammas and X-rays tend to produce transient effects. Neutron interactions with target materials produce displacement effects in solids, as well as heating and ionization in both the solid and gas phases. Gamma and X-ray interactions are mainly confined to ionization, charge scattering, and heat-

ing; although, permanent effects may also result from these interactions. Neutrons can produce transient effects from short-term ionization, or as a result of the gammas produced by the neutron interaction

The absorption of a large amount of energy ($> 50\text{j/g}$) by an organic material in a very short time ($< 1\ \mu\text{sec}$) results in a correspondingly large increase in its internal energy. Because most energetic materials are poor thermal conductors, the absorbed energy is manifested as a rapid temp rise (ΔT) in the sample. Several types of response to this ΔT are observed. In consolidated "nonreactive" organic substances, cracking, spallings and gas evolution commonly occur due to the generation of stress waves within the pieces and radiolytic decompn of the compds. The extent of damage is related to total dose, exposure time (dose rate in some instances), and the physical properties of the material. Materials such as the PEP's which decompose energetically at elevated temps undergo similar responses to the "nonreactive" organics but also can undergo violent decompn if the ΔT is sufficiently large. To achieve a ΔT of this magnitude in PEP materials with a neutron burst requires a sizeable incident fluence and a short exposure time (burst), ie, at least $10^{13}\ \text{n/cm}^2$ in a few microseconds. Neutrons (and gammas) represent only a small fraction of the total energy available in a nuclear burst and they are only important (in terms of energy deposition) in X-ray hardened targets or at lower altitudes ($< 30\ \text{km}$) where much of the X-ray energy is absorbed by the atmosphere. Therefore, relatively close encounters with nuclear bursts are necessary to produce neutron radiation damage that would be sufficient to cause malfunction. Malfunction in this context refers to significant changes in proplnt burn rate, case debonding, decreased output of the expl, premature firing of pyrotechnics, etc

Nuclear weapon expts on expls and ordnance materiel began with Operation Crossroads (Test Able) in 1946. Ordnance materiel exposed in Test Able was examined by PicArns (Refs 19, 20, 22, 24 & 25) and subjected to a series of tests. The ordnance items included M2A3 Shaped Charge (50/50 Pentolite), M1A1 Bangalore torpedo (TNT, 80/20 Amatol), demolition smoke charge (TNT, 80/20 Amatol), TNT

SAMPLE: BARIUM AZIDE
BaN₆

SIZE 2mm ATM N₂

REF. GLASS BEADS

PROGRAM MODE HEAT SCALE 50 °C/INCH 2.0 °C/INCH

RATE 20 °C/MIN

ORIGIN: CONTROL AND
CO⁶⁰ IRRADIATIONS

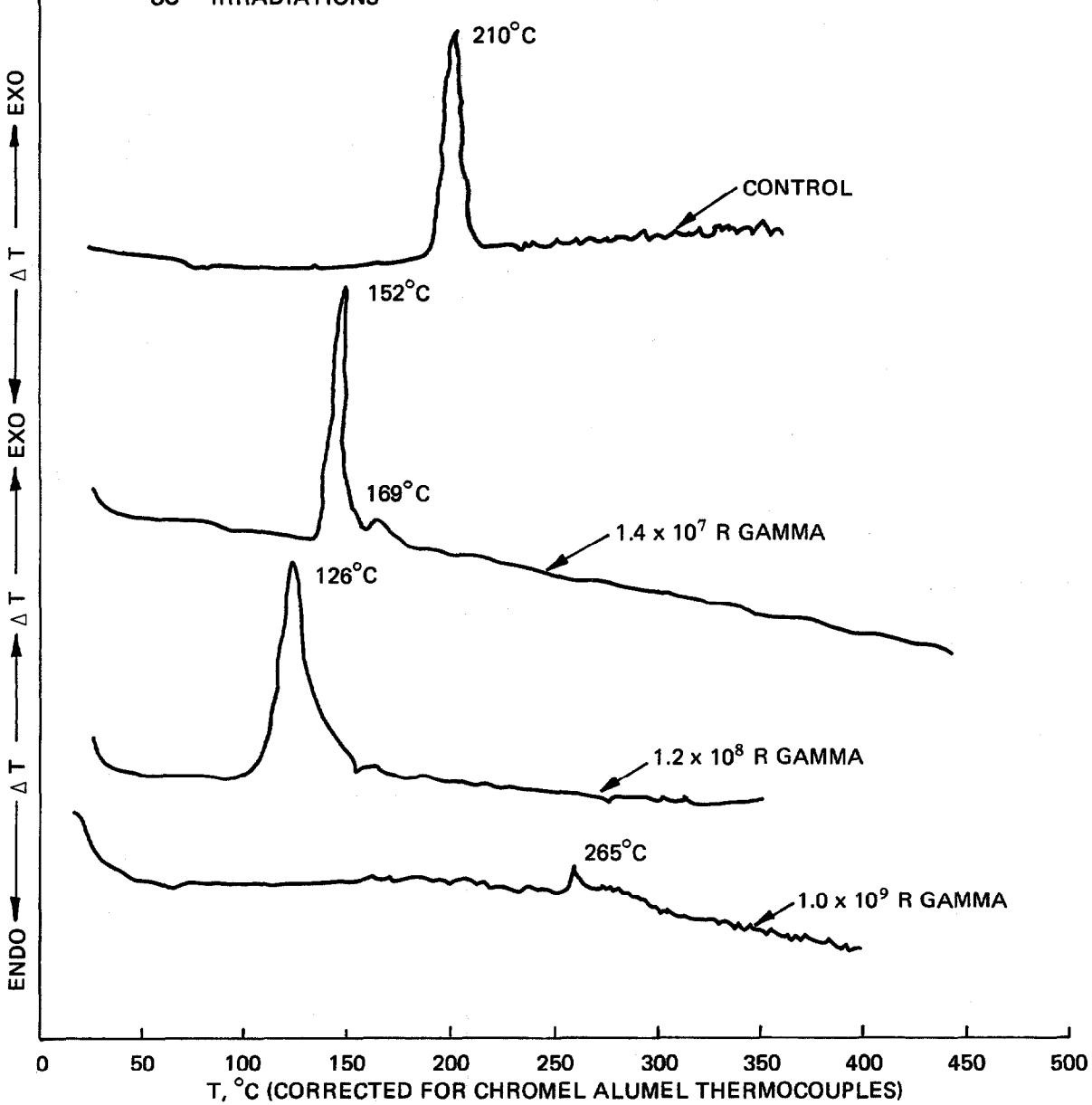

Fig 14 DTA Thermograms for BaN₆ as a Function of Gamma Dose (Ref 223)

Table 11
Effect of Gamma Irradiation on Various Lead Azides (Ref 257)

Lead azide	Gamma radiation dose (R) ^a		
	Control	1.0 x 10 ⁸	1.16 x 10 ⁹
Dextrinated			
Color			
Powder	White	Dark gray	Yellow
Pellet	White	Dark brown	Light brown
Weight loss (%)			
Powder	--	-7.5	-14.5
Pellet	--	-0.9	-9.2
PA impact, 10% reactions (inches)	7	6	> 36 (powder) > 36 (pellet)
Vacuum stability (ml/g/40 hours at 100°C)	0.47	1.35	0.57
RD-1333			
Color			
Powder	White	Dark gray	Brown
Pellet	White	Dark brown	Light brown
Weight loss (%)			
Powder	--	-6.4	--
Pellet	--	--	--
PA impact, 10% reactions (inches)	6	6	11 (powder) 16 (pellet)
Vacuum stability (ml/g/40 hours at 100°C)	0.38	7.18	2.06
PVA			
Color			
Powder	White	Dark gray	Brown
Pellet	White	Dark brown	Brown
Weight loss (%)			
Powder	--	-7.8	-14.0
Pellet	--	-1.5	--
PA impact, 10% reactions (inches)	8	4	11 (powder) 21 (pellet)
Vacuum stability (ml/g/40 hours at 100°C)	0.28	5.58	1.04

^a Dose Rate -- ⁶⁰Co Gammas, 3.2 x 10⁵ R/hour

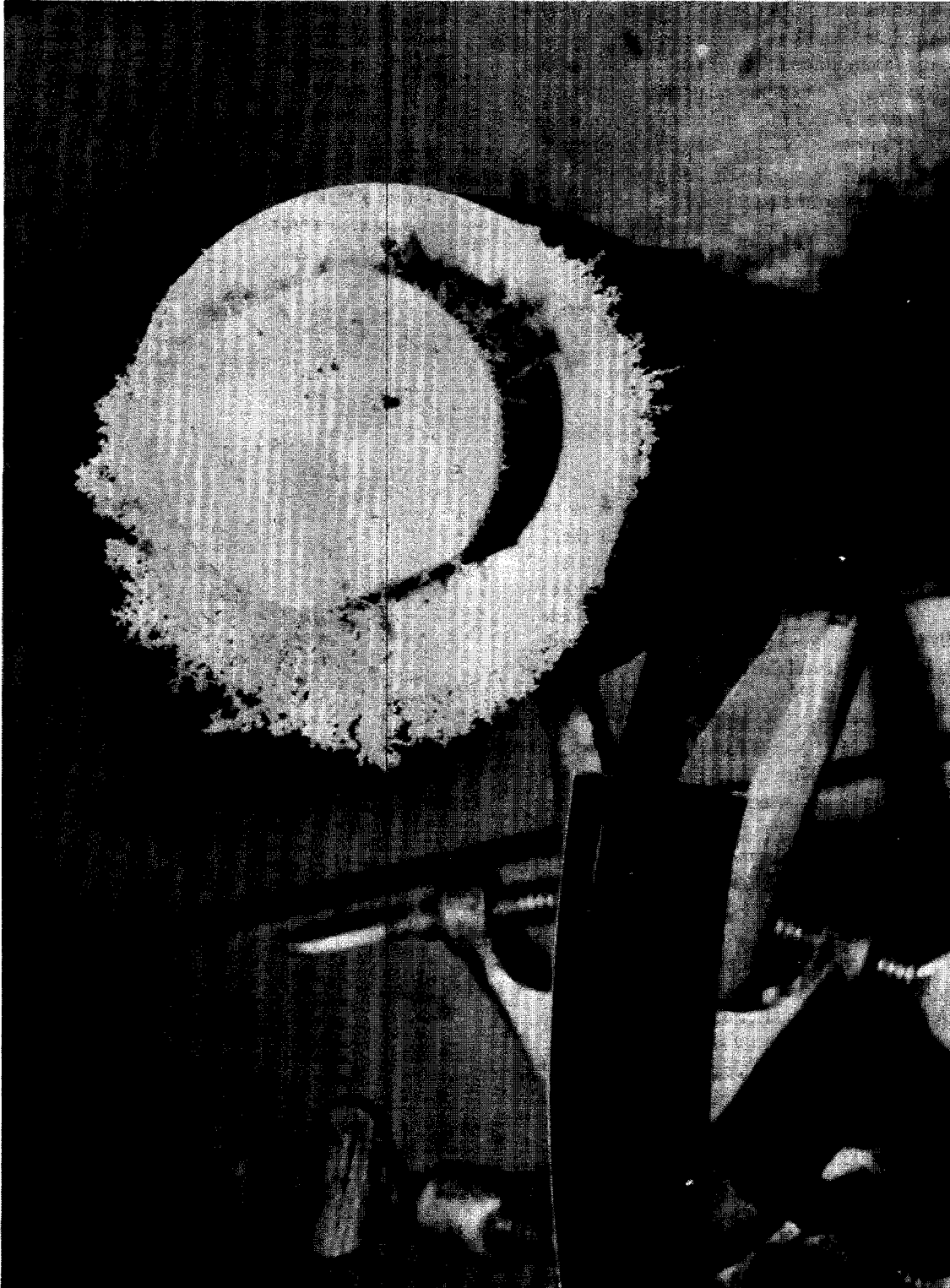

Fig 16 Formation of Ammonium Nitrate on Top of Irradiation Explosion Proof Capsule Containing Lead Azide. Subjected to a 1.16×10^9 R Gamma Dose (Refs 254 & 257)

block, demolition block (75/25 Tetrytol, Tetryl), M3 demolition block (Composition C3), cratering expl (ammonium nitrate), and detonating cord (PETN). The expl materials in these items were tested after exposure and then six months later after storage at 65°. No effects were noted. However, the exposure levels and the time interval from exposure to testing were not given. The artillery ammo included samples of proplnt powder (compn not given), BlkPdr, TNT, and a primer mix consisting of K chlorate, Pb thio-cyanate, Sb sulfate and PETN. No effects were recorded with these materials

In a similar program the Armour Research Foundation (Ref 41) irradiated both alpha and beta Pb azide in an intense X-ray beam. The dosages were not indicated but both types of crystals showed extreme deterioration, marked red discoloration, and a breakup of crystal morphology; however they did not detonate. Another effect was the appreciable reduction of the intense absorption band starting at 270

e) X-Ray Irradiation

The irradiation of expl materials by X-rays dates back to the nineteen thirties with the expts of Muraour (Ref 11) in trying to initiate nitrogen iodide, and Gunther, Lepin and Andreev (Refs 4 & 18) with decompn studies on Ba azide

In 1948 a study was conducted at the Aberdeen Proving Ground, Maryland (Refs 21 & 48) where samples of TNT, Tetryl, Pb azide, BlkPdr, and three proplnts (M1, M8, and M15) were exposed to 1 MeV X-rays for one hour at a dose rate of 12 R/sec. With a total dose of 4×10^4 R no rise in temp was observed nor any significant changes in sensitivity were detected

Decompn studies were pursued by Heal (Refs 30 & 52) who used 44.5 kVp X-rays with 45 mA on Na azide and established that no nitride ions were formed during the decompn, because the nitride ion was rapidly converted to the colorless amide ion (Ref 193)

Bowden and Singh (Ref 35), in their efforts to initiate primary expls by all types of nuclear radiation, used 220 kV X-rays with a beam strength of 15 mA and an intensity of 700 R/min. Crystals of Pb and Ag azide were irradiated for 2 hours and no explns were obtained. In the wavelength range between 0.06 and 0.4Å the absorption of energy takes place thru photo-electric effect and Compton recoil. With crystals 2 mm thick, only a small percentage of the energy is absorbed and the only effects noticed were color changes and metallic nuclei produced on the surfaces

millimicrons which was believed to be the same kind of behavior that F and V centers in the alkali halides exhibit on X-ray bleaching

The effect of high energy X-rays were studied by Grocock and Phillips (Refs 42 & 59). Small samples (2 mg) of service Pb azide were irradiated in air with X-rays from a 1 MV generator and the effect on the time to expln was observed. Actually below a dosage of 10^6 R no observable effect was found, but with a total dose of 6.35×10^6 R the time to expln at any given temp was only one-fifth of that for the unirradiated material. The min temp for expln was reduced from about 310° to 295° . With α -Pb azide Grocock (Ref 59) performed the same type of expts. Below 10^4 R the thermal decompn and expln temp characteristics were unchanged. With higher doses the decompn rates are changed and the expln times are reduced. This effect is shown in Fig 17 for decompns conducted at 298° as a function of dose

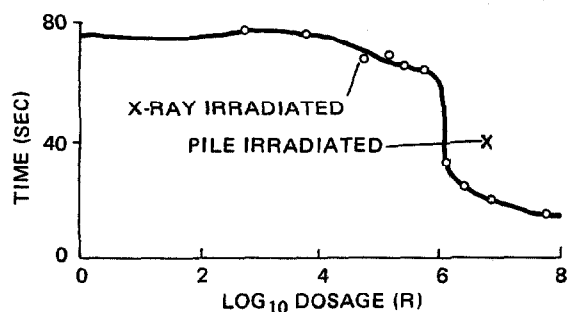

Fig 17 Variation of Time to Explosion with Preirradiation X-Ray Dosage for Decompositions at 298°C (Ref 59)

For comparison purposes Grocock also irradiated a Pb azide sample in the Harwell BEPO reactor pile for five hours. For the same energy deposition, pile irradiation was found to be slightly less effective than high energy X-rays in altering the reaction kinetics of a subsequent thermal decompn. Grocock also observed that the friction sensitivity of service Pb azide irradiated with X-rays at total doses of 10^4 R and 10^7 R did not show any effects or changes when tested with the sliding block friction test

Some of the radiation-induced changes caused by X-rays were shown by Todd and Parry (Refs

70 & 79) with α -Pb azide. The hardness of that material is severely modified by exposure to soft X-rays. With an X-ray dose rate of 1.4×10^5 R/min in air an anomalous β -axis habit expansion of the decompn crystal was observed. More than 97% destruction of the azide was achieved with a total dose of 3.4×10^8 R. It was also shown that the stable end-product of X-ray decompn in normal air is basic Pb carbonate of the formula $2\text{PbCO}_3 \cdot \text{Pb}(\text{OH})_3$. The conversion is complex. After a dose of 6.7×10^7 R there is evidence for partially disoriented residual Pb azide together with a disoriented unidentified phase. Higher doses produced a further unidentified phase before stable basic Pb carbonate was finally formed

Most of the studies conducted on azides irradiated with X-rays have been involved with the changes caused in the subsequent thermal decompn of the expl material. A comprehensive study by Yerofeyev and Sviridov (Ref 102) on Ba azide included the effects of moisture and aging. An increased decompn rate was also noted with Sr azide pre-irradiated with X-rays and decompd at 126° (Ref 71). Zakharov and his co-workers (Refs 181, 182 & 196-198) studied the decompn of Pb azide and Ag azide under the action of X-rays and fast protons and the degree of decompn was judged according to the amount of nitrogen retained in the crystal lattice of the azide. The degree of decompn was found to be proportional to the absorbed dose. The addition of Ag^+ in Pb azide accelerated radiolysis while C^{++} decelerates it. With Ag azide, Pb^{++} substantially increases the rate of formation of radiolytic nitrogen. The expts also included the effects of introducing hetero-phase semiconductor additives on the radiation stability of Pb azide

As with gamma radiation, X-rays in the steady-state mode have not produced any initiations in any of the expls irradiated. Effects are being directed towards intense, pulsed irradiations in order to simulate nuclear weapons effects. The prospect of higher dose rates in short time frames should produce results not common to the steady-state irradiation

f) Electron Irradiation

Steady-State

The electron bombardment of expls has been

undertaken by various investigators in an effort to initiate or decomp the material under study. One of the early investigations was undertaken by Kallman and Schr nkler (Ref 9) who bombarded TNT, MF, NC and, to some extent, picrates and azides with 10000 volt, 1 milli-ampere electrons in vacuo, but were unable to produce any explns. However, when heavier ions of argon and mercury were used, initiations were achieved on all the materials with each of the ions. Muraour (Ref 10) subjected Pb azide and Ag acetylide to 90000 volts, 3 milliamperes for 3 minutes and only achieved expln with Ag acetylide. The only other effect reported was that both expls blackened upon the electron irradiation. Muraour believed that the expln was either a thermal effect or that, by chance, a sufficiently large number of molecules decompd at one point to bring about complete decompn

Bowden and Singh (Refs 28 & 35) achieved expln of Pb and Ag azide when crystals of these azides were irradiated with an electron beam of 75 kV and 200 μ amp. The times of the irradiations were not given. The expln is partly due to the mass heating of the crystal by the electron beam. To substantiate this, crystals of

K chlorate with a mp of 334 $^{\circ}$ readily melted in the beam showing a temp rise close to the expl temp of those azides. What role the high-energy electrons play is not clear but some electronic excitation must take place. Sawkill (Ref 39) investigated the effect of an electron beam from an electron microscope on both Pb and Ag azide. If expln did not take place, color changes and nucleation occurred and cracks developed within the crystal which broke up into tiny blockets about 10^{-5} cm across. These are believed to be associated with a substructure in the crystal. In Ag azide the progression to Ag is pronounced and it does not follow the thermal decompn route

The decompn of various azides by electron bombardment has been studied by a number of investigators. M ller and Brous (Refs 5 & 8) studied Na azide, and Groocock and Tompkins (Ref 38) also investigated Ba azide by this technique. Groocock (Ref 80) continued his expts with α -Pb azide and produced a curve similar to the ones for Ba and Na azides. In all of these studies only gas evolution was studied. An interesting feature observed by Groocock was a decompn mechanism varying with the thickness of the azide layer which implied that

Table 12
Effects of 60-MeV Electron Irradiation on Explosives (Ref 217)

Explosive	Weight (mg)	Dose (R)	Dose Rate (R/sec)	Weight loss	Color Change	Test	Result
Lead azide	25.0	1.14×10^9	1.6×10^6	None	Dark brown	Heat ^a	Explosion
	4.0	3.65×10^{10}	2.9×10^6	None	--	Heat	No explosion
	11.0	2.96×10^{10}	2.7×10^6	None	--	Heat	No explosion
	12.8	1.14×10^{10}	1.1×10^6	--	--	Impact ^b	No explosion
	19.3	1.37×10^{10}	2.3×10^6	9%	--	Impact	No explosion
Lead styphnate	25.0	1.14×10^9	1.1×10^6	--	Dark rust brown	Heat	Explosion
	25.0	1.14×10^9	1.6×10^6	--	--	Heat	Explosion
	3.3	3.65×10^{10}	2.9×10^6	--	--	Heat	No explosion
	7.9	2.96×10^{10}	2.7×10^6	--	--	Heat	Explosion
	10.3	22.7×10^{10}	2.9×10^6	--	--	Impact	Explosion
TNT	8.0	1.14×10^9	1.7×10^6	None	Caramel	Impact	Explosion
HMX	7.7	1.14×10^9	1.7×10^6	--	--	Impact	No explosion
PETN	14.0	1.14×10^9	0.6×10^6	None	Gray	Heat	Sample evaporated

^a Put on hot plate with temperature above explosion temperature

^b Samples tested at 100 cm with NOL apparatus

for small thicknesses, the effects are rather electronic than chemical in nature (Ref 187)

Steady-state electron bombardment of high expls have been conducted with one of the earliest investigations by Roginski (Ref 7) on NG. Berberet (Ref 141) subjected RDX, HMX, TNT, TNB, DATB, Tetryl and some fluoro-derivatives to 3 and 40 MeV electrons up to 2 hours for total doses of about 7.3×10^8 R

Using a 60 MeV electron beam from a linear accelerator, Farber (Ref 217) subjected Pb azide, Pb styphnate, TNT, HMX and PETN to total doses up to 3.65×10^{10} R (3.2×10^{10} rads). The results as shown in Table 12 indicate that ionizing radiation from 60 MeV electron irradiation will completely desensitize Pb azide, according to impact and heat tests conducted on the irradiated samples. The type of Pb azide was not given. A total dose of 3.65×10^{10} R appears to be the threshold level for "dudding" of Pb styphnate

Pulsed Electrons

Much interest has been focused recently on the initiation of expls by very intense beams of fast electrons with pulse durations in the nano-second range. For the most part the critical energy deposition doses observed are much lower than those required for mass heating which would heat the expl uniformly until the expl or initiation temp is reached

Phung (Ref 201) attempted to apply the thermal "hot-spot" theory to pulsed-electron

initiation by proposing a stochastic model which was based on the nonuniform spatial distribution of energy packets arising from the absorption of electrons or photons. In his special hot-spot model, Phung divided his expl sample into spheres called cells with a dimension of about 5×10^{-7} cm in radius. Electron or X-ray energy is deposited in small packets of various sizes and at random sites. As the dose is increased, the spatial distribution becomes more randomized and the probability of packets of absorbed energy falling on top of one another increases. With computer calcs using an appropriate heat conduction equation the average temp (or dose) and corresponding hot-spot temp required for initiation were determined. Critical doses were calcd for PbN_6 , BaN_6 , Pb styphnate, PETN, RDX, HMX and NG and compared with the preliminary exptl data shown in Table 13. Although differences can be seen, Phung believes that the correct order of magnitude of the calcd results be considered as evidence supporting the thermal mechanism in initiation of expls by high-energy radiations

Pulsed-electron irradiation expts are usually conducted with accelerators charged from 0.1 to 6.0 MeV and pulse durations ranging from 3–60 nsecs. The expls are pressed pellets with thicknesses of about 0.2 of the electron range. Calorimeters are used to measure the fluences. If the samples are too thick the electrons will be trapped in the material causing a very nonuni-

Table 13
Critical Doses and Temperatures to Initiate Explosives
by Pulsed High-Energy Electrons (Ref 201)

Explosives	Critical dose (J/g)		Ignition temperature (°C)	
	Calculated	Experimental ^a	Calculated	Experimental
PbN_6	158.2	46	57	327–360
PETN	89.6	> 167	222	205–225
RDX	1.61	> 167	300	229–260
HMX	156.1	> 167	310	335
Nitroglycerine	90.4		255	215–218
Pb styphnate	92.1	normal 42 basic 75		
BaN_6	94.2	80		

^a Estimated 50% initiation dose

Table 14
Initiation of Lead Azide by Pulsed Electrons (Ref 232)

Type of Lead Azide	Sample			Responses produced		Average dose to lead azide (J/g)	
	Density (g/ml)	Thickness (inch)	Gas pressure	Number initiated	Number surviving	Highest surviving sample	Lowest initiated sample
Dextrinated	2.78	0.030	1 atm	1	8	124.6	150.7
	2.80	0.060	1	6	9	92.1	83.7
	2.82	0.090	1	4	11	100.5	92.1
	2.80	0.060	2 μ m	9	5	46.0	41.9
	2.82	0.090	2	11	2	6.7	10.0
RD-1333	2.95	0.060	1 atm	3	9	92.1	96.3
	2.95	0.060	2 μ m	3	0	0	23.0

form dose. Further, the resulting space charge causes dielectric breakdown and initiation is reduced by electric discharge rather than by absorbed radiation

A series of pulsed electron beam tests were conducted on dextrinated and RD-1333 Pb azide pellets by Avrami et al (Ref 232). From the limited data in Table 14 it can be seen that sample ambient pressure, sample thickness and type of Pb azide are all important factors in the sensitivity of initiation by pulsed electron beam

The question arises as to what mechanism can explain the observed pressure, thickness and type of Pb azide dependence. A purely thermal initiation mechanism or a compressive shock initiation resulting from nearly instantaneous energy deposition can account for some of the observations but not all

If it is assumed that all the energy deposited in the Pb azide is used to heat the material instantaneously and that heat losses do not occur during the energy deposition time, the max possible temp rise is obtained by

$$T_{\max} = T_{\text{ambient}} + \frac{\text{Energy deposited (J/g)}}{C_p(\text{J/g}^\circ\text{C})}$$

For an initiation dose of 151J/g (36 cal/g), an initial sample temp of 23° and a heat capacity of 0.46–0.57J/g°C (0.11–0.136 cal/g°C), the max possible temp achieved in the Pb azide is 288–349°. The 5-sec expln temp reported for Pb azide is about 340°. Thus, a purely thermal

initiation mechanism may account for the highest initiation dose responses but the mechanism does not account for most of the data

The response of the Pb azide to the compressive shock waves resulting from the nearly instantaneous energy deposition may also account for some of the observations, but this mechanism cannot account for the observed initiations at the low doses. A calcn of the stress wave history of a sample exposed to the electron beam was made using the electron-beam pulse width, the energy deposition profile and equation-of-state parameters for the materials irradiated (Ref 248). It is possible that a compressive shock initiation mechanism could account for initiations of samples receiving doses in excess of 84J/g (20 cal/g). Even with an uncertainty as much as a factor of three, the large number of initiations at low doses are still not explained. Electric field-induced initiation (Ref 233) is an alternative mechanism which is able to account qualitatively for all the observed test results. During energy deposition from the electron beam, charge deposition occurs thruout the volume of the sample and produces electric fields in the sample. The charge deposition curves, usually calcd by Monte Carlo electron transport codes, are roughly similar in shape to the energy deposition profiles for the sample geometries used in the expts

However, the absence of radiation-induced conductivity data at relevant doses and dose

rates for the materials studied prevents calcn of the critical electric field(s) at the observed initiation dose thresholds. However, the initiation data can be explained qualitatively by the proposed electric field initiation mechanism. The mechanism is applicable to other expls and initiating mixes and applicable also to photon as well as electron irradiation, since photon irradiation can produce non-zero charge distributions (and electric fields) in dielectric materials

This electric field-induced initiation concept is based on pulsed radiation. If a determination of a critical electric field is made in the absence of radiation it is probably not relevant to this area of radiation-induced effect since the critical field for an ionized material is likely to be very different from that for a non-ionized material

g) Other Types of Nuclear Irradiation

Other forms of radiation used to induce changes in different chemical and physical properties of expl azides have included protons, deuterons, ultraviolet light, visible light and lasers

In Fig 1 the range-energy relations for α -particles and protons were plotted. The ranges for protons were calcd by Cerny et al (Ref 109) as listed in Table 15 and, as stated previously, the α -particle ranges were obtained from the established proton ranges

On the exptl side, the results of Ryabykh et al (Ref 182) on single crystals of Pb azide, pure and containing Ag^+ and Cu^{++} , indicate that proton irradiation produces a more rapid radiolysis than X-ray irradiation. With an energy of 4.8 MeV, the protons were entirely retained by the largest crystals permitting the range of protons to be measured directly ($\sim 0.7\text{mm}$). During the expts it was found that the sensitivity of PbN_6 crystals to the action of radiation increases with aging. Actually the yield in nitrogen in crystals six months old was more than twice as much as that in freshly-made crystals under identical conditions of irradiation. As with X-ray irradiation, the addition of Ag^+ accelerated radiolysis, while the reverse was evident with Cu^{++} , but more pronounced

Crystalline azides, bromates, and nitrates of alkali metals were irradiated by 4.7 MeV protons and also by Co^{60} gammas by Oblivantsev et al (Ref 200) and Boldyrev (Ref 209), and their

radiation stabilities were compared to their thermal stabilities. Also determined were the range and loss of energy of 4.7 MeV protons in alkali azides

Berberet and Kaufman (Ref 121) attempted to produce ignitions with 12 MeV and 24 MeV deuterons in samples of Composition B and HMX/Exon instrumented with micro thermocouples. Ignition was achieved in both materials, but only at elevated temps. The anomalous thermal behavior indicated by the thermocouples suggested to the experimenters that a stored energy phenomenon as well as the elevated temp played an important role in the ignitions. There was further evidence of an apparent dependence of the ignition on the total exposure rather than on temp

The action of ultraviolet (UV) radiation on Pb azide was reported by Garner and Gomm (Ref 6) who indicated it was not possible to detonate Pb azide crystals by UV light from a mercury vapor lamp. However, it was noted that the crystals turned black from the irradiation and in this state were more sensitive to heat. Muraour (Ref 1) tried unsuccessfully to initiate nitrogen iodide as well as other expls with UV rays as well as α - and X-rays

The effect of UV radiation on other azides was conducted by Müller and Brous on Na azide (Ref 8), by Garner and Maggs on Ba and Sr azides (Ref 16), by Mott on metallic azides (Ref 17), and by Boldyrev and Skorik on Ag and Ba azides (Ref 144). With Na, Sr and Ba azides, each are decompd by UV light at room temp and the thermal decompn of these materials is accelerated by pre-irradiation. Boldyrev et al found that irradiating Ag azide with UV light or X-rays at the instant of decompn had no effect on the rate of its thermal decompn

The photolysis of Pb azide crystals by UV light was studied by Dodd at the University of Arkansas (Ref 44). The results indicated that UV radiation can partially decomp Pb azide and that wavelengths shorter than 3200\AA are required

The effect of UV radiation on the sensitivity of Pb azide was pursued by Abel and Levy (Ref 153) who observed that changes occurred in the impact and thermal sensitivity of colloidal Pb azide. The effects can be seen in Fig 18 where the 50% point was lowered significantly before returning near its original height as a function of

Table 15
 Ranges of $\sim 0-25$ MeV Protons in Various Explosives (Ref 109)

Range (mg/cm²) in:

Energy (MeV)	RDX or				Lead styphnate	Mercury fulminate	Lead azide
	TNT	TNT	PETN	Tetryl			
0.020	0.069	0.070	0.073	0.072	—	—	—
0.040	0.10	0.10	0.10	0.10	—	—	—
0.050	—	—	—	—	0.22	0.35	0.34
0.060	0.12	0.13	0.13	0.13	—	—	—
0.080	0.15	0.15	0.15	0.15	0.29	0.45	0.44
0.100	0.17	0.18	0.18	0.18	0.33	0.52	0.51
0.150	0.24	0.24	0.25	0.25	0.44	0.69	0.67
0.200	0.31	0.31	0.32	0.32	0.56	0.86	0.85
0.250	0.40	0.40	0.41	0.41	0.69	1.06	1.05
0.300	0.49	0.49	0.50	0.50	0.85	1.27	1.27
0.400	0.71	0.71	0.72	0.72	1.19	1.75	1.76
0.500	0.96	0.96	0.98	0.98	1.58	2.31	2.33
0.600	1.25	1.25	1.27	1.27	2.03	2.94	2.97
0.700	1.57	1.57	1.59	1.60	2.52	3.63	3.68
0.800	1.92	1.92	1.95	1.96	3.06	4.39	4.45
0.900	2.30	2.31	2.33	2.35	3.64	5.20	5.28
1.00	2.71	2.72	2.75	2.76	4.27	6.06	6.17
1.50	5.15	5.19	5.22	5.23	7.95	11.1	11.4
2.00	8.22	8.32	8.36	8.37	12.5	17.5	17.8
3.00	16.3	16.4	16.6	16.6	24.1	33.3	34.1
5.00	39.5	39.7	40.0	40.1	57.1	76.7	78.9
7.00	71.5	72.0	72.6	72.8	102	134	138
10.00	135	136	137	137	190	244	251
13.00	216	217	219	220	300	382	392
16.00	315	316	318	319	433	545	560
19.00	430	431	433	435	587	733	753
22.00	561	562	564	567	761	944	969
25.00	707	708	711	715	957	1177	1209

UV irradiation. A similar pattern is evident for the induction time, while as expected, the reverse is true for the activation energy

The more recent expts involving UV and X-ray irradiations were performed by Wiegand (Ref 226) who determined the changes in the optical properties of Pb and thallos azides. The same type of extinction due to colloidal metal was caused by both types of radiation and is increased in magnitude with decreasing wavelength to the band edge

The initiation of expl azides and other sensitive primary expls by means of a high-intensity short-duration light source has been studied

extensively during the past twenty-five years ever since the first announcement at the International Conference on Photography at Bristol, England in 1950. The results of Eggert and his co-workers (Refs 32-34 & 36), Bowden and his co-workers (Refs 56 & 73), and Roth (Ref 132) have put forth a critical initiation energy that depends on the expl, its initial temp, the flash duration and less clearly on the absorption coefficient used

Materials studied by Eggert and his colleagues are listed in Table 16. Eggert (Refs 72 & 74) and Courtney-Pratt and Rogers (Ref 40) believe that the initiation of expln by light is thermal. The

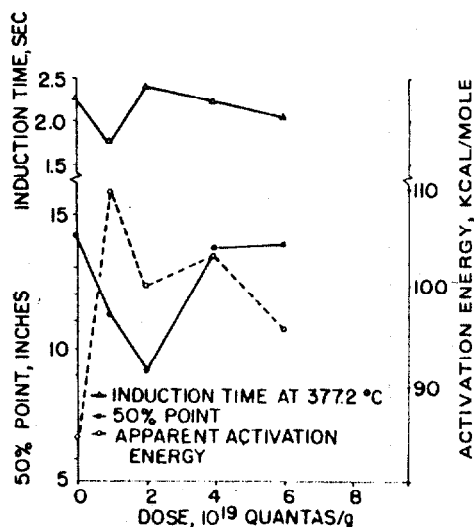

Fig 18 Effect of Ultraviolet Irradiation on Induction Time, 50% Point, and Activation Energy of Colloidal Lead Azide (Ref 153)

azide is excited electronically by the absorption of light in a thin surface layer of the crystal and this excitation energy is degraded into heat in a short time interval (1–50 μ sec). The subsequent expln then occurs by a normal thermal mechanism

However Deb, Evans and Yoffe (Ref 82) produced results that indicated, at least for TiN_3 , AgN_3 and CuN_3 , primarily the initiation of decompn is photochemical, with the growth to expln being thermal. The initial step is the final formation of an azide radical and an electron in the conduction band:



followed by the exothermic steps:



and:

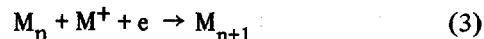

where M represents the metal forming the azide, and these will control the growth to expln

Table 16
Minimum Ignition Energies of Explosives by Light Flashes (Refs 32 & 72)

Compound	Formula	Color	Thermal ignition temperature ^a (°C)	Electrical energy of flash, half-life 0.8 msec (J)	Light intensity (J/cm ²)
Nitrogen iodide	$NI_3 \cdot NH_3$	Brown-black	50	19	0.16
Silver nitride	Ag_3N	Black	100	24	0.20
Cuprous acetylide	Cu_2C_2	Brown-black	120	75	0.63
Silver acetylide	Ag_2C_2	White	165	95	0.79
Silver acetylide	$Ag_2C_2 \cdot AgNO_3$	Yellow-white	225	230	1.9
Mercurous acetylide	Hg_2C_2	Light grey	280	> 350	> 2.8
Mercuric acetylide	HgC_2	White	260	180	1.5
Silver azide	AgN_3	White	250	310	2.6
Lead azide	$Pb(N_3)_2$	Yellow-white	350	240	2.0
Mercurous azide	$Hg_2(N_3)_2$	White	—	> 300	—
Mercuric azide	$Hg(N_3)_2$	White	270	310	2.6
Silver fulminate	$AgONC$	White	170	250	2.1
Mercuric fulminate	$Hg(ONC)_2$	Light grey	190	200	1.65
Benzene diazonium nitrate	$C_6H_5N_3O_3$	Yellow	90	110	0.92
Benzene diazonium perchlorate	$C_6H_5N_2ClO_4$	White	155	110	0.92
p-Diazo-diphenyl-aminoperchlorate	$C_{12}H_{10}N_3ClO_4$	Yellow	170	95	0.79
Ammonium perchromate	$(NH_4)_3CrO_8$	Red-brown	90	135	1.1
Silver oxalate	$Ag_2C_2O_4$	White	140	> 300	—

^aSmall quantities placed in a heated aluminum block and exploded within 30 secs

The question whether initiation by light is primarily a thermal or photochemical process has been pursued on an analytical and exptl basis. Blanchard (Ref 114) undertook a theoretical study by assuming the initiation of expls by monochromatic light to be of a thermal nature without photochemical effects. Deriving differential equations relating temp, time and distance below the surface of the expl crystal to specific heat (C), density (ρ), thermal conductivity (K), heat of reaction and activation energy (E_a), and applying these to PbN_6 and AgN_3 , a relationship was obtained between the intensity of illumination and initiation delay that agreed with exptl data. Not taken into consideration was the variation of the specific heat with temp. Also exptl values were not available for the absorption coefficient for expts conducted with monochromatic light. The simplified equation of heat flow used is as follows:

$$C_p \rho \frac{\partial T}{\partial z} = K \frac{\partial^2 T}{\partial z^2} + \rho Q A e^{-E_a/RT} + \alpha E_0 e^{-\alpha z} \quad (4)$$

where α is the absorption coefficient, Z the thickness coordinate of the crystal and E_0 the incident light flux per second

Roth (Ref 132) made measurements of initiation delay for different absorbed energies by initiating PVA-Pb azide pellets with light radiation from an argon flash bomb in order to provide insight on the thermal or photochemical aspects of the initiation mechanism. The initiation delay was measured by optical methods as a function of energy absorbed by the Pb azide. The results indicated that the product of the rate of energy absorption and the initiation delay is constant and that the initiation is thermal in origin; for the exptl conditions used the photochemical reactions are unimportant. The thermal mechanism is interpreted in the following steps: the high-intensity light absorption causes a continuing increase in the azide surface temp to above a critical temp, which in turn triggers a very rapid exothermic decompn leading to thermal expln and detonations in very short times. The ignition delays are in the order of $1 \mu\text{sec}$ and the critical temp $\sim 900^\circ\text{C}$

Courtney-Pratt and Rogers (Ref 40) studied the ignition of Ag azide crystals by high-intensity ultraviolet light flashes and determined the critical initiation energy input to be $.33 \text{ J/cm}^2$

($8 \times 10^{-4} \text{ cal/mm}^2$). The initiation delay time for Ag azide was estimated to be about 15–20 μsecs (Ref 57)

Bowden and his co-workers concentrated much of their efforts on the monovalent inorganic azides and derived an order of sensitivity to light initiation: $KN_3 < TlN_3 < AgN_3 < CuN_3$. Also reported was that Pb azide and cuprous azide may be expld by a high-intensity light flash, but required a lower minimum flash energy for ignition than Ag azide

The ionic azides can be sensitized or desensitized to light by the introduction of foreign anions (Refs 80 & 114) (Table 17). Metal particles such as Au (Fig 19) sensitize Ag azide while electron donors such as HgI_2 desensitize it. These results may be explained in terms of the electronic processes that occur in the solid during decompn. The metal particles act as electron traps and thus enhance decompn, while with HgI_2 the reverse occurs and the electron density is increased

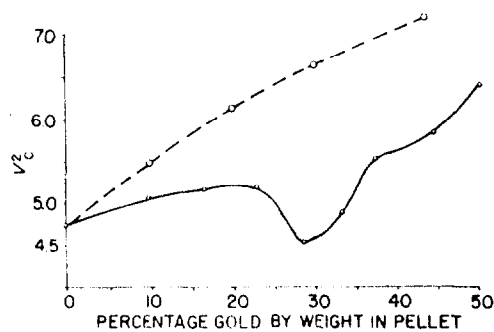

Fig 19 The sensitization of silver azide to light due to the effect of gold particles (Ref 80). The dotted line corresponds to ignition for equal intensities; the solid line shows the experimental curve. V_c is the charging voltage in kV; capacity, $8 \mu\text{F}$

The effect of crystal size on the critical light energy or initiation delay was reported by Bowden and Yoffe (Ref 57) for Ag azide and by Roth (Ref 132) for Pb azide. Each found that crystal size had no effect. Roth pursued this further and reported that the packing density range 1.6 to 3.2 gm/cc, and the particle size range 0.5 to 10 μ had no effect on the initiation

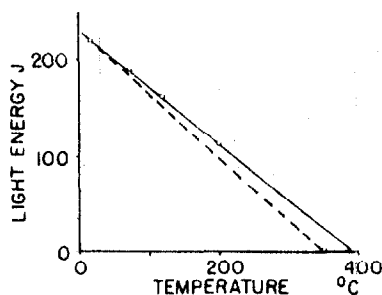

Fig 20 The relationship between light energy for ignition and temperature for lead azide (Ref 32). The solid line gives the experimental curve; the dotted line connects the value for the ignition energy at 20°C and the point on the temperature axis corresponding to the thermal ignition temperature

Table 17
Light-Flash Ignition Energies
for Azides and Mixtures (Ref 80)

Explosive	Critical flash ignition energy (J)
PbN ₆	28.8
PbN ₆ + 0.1% graphite	32.0
PbN ₆ + 0.35% graphite	34.0
PbN ₆ + 1.65% graphite	52.0
AgN ₃	48.0
AgN ₃ + 10% PbI ₂	62.0
AgN ₃ + 10% HgI ₂	72.0
TlN ₃	92.2
TlN ₃ + 7% Tl ₂ CN ₂	< 200

delay. Also, impurities of 15% Formvar (organic) and 1–4 minutes of sunshine did not affect the initiation delay

The effect of temp on the light energy required to initiate various expls was studied by Berchtold and Eggert (Ref 32) with Pb azide and Ag acetylide, and by Merckämper (Ref 36) with nitrogen iodide. Fig 20 shows that the relation is linear for Pb azide. The dotted line represents the curve from the "dark" ignition temp of 350° obtained by heating Pb azide for 30 secs in the absence of light. The number of data points are not known but the two curves are reasonably close. Eggert and his colleagues regarded this result as further evidence for the thermal initiation mechanism. Bowden, however, pointed out

that the heating rate was not considered, ie, for thermal ignition a delay of 30 secs was required, while in photo-initiation the delay may be in the order of microseconds

Other materials of interest which have been studied relative to the effects of light radiation are Ag nitride, Ag iodide, Pb azide, and Ag acetylide-Ag nitrate (SASN)

Ag nitride is a black material and consequently absorbs light over the whole visible spectral region (Ref 32). There is no evidence that Ag nitride is more sensitive to light of any particular wavelength, the minimum critical energy for ignition being identical for visible, ultraviolet or infrared radiation. Berchtold and Eggert found that the energy required to initiate is dependent on the duration of the incident flash with the equation

$$E = 8\sqrt{t}$$

where E is the energy of the incident light (J/cm²) for initiation and t the duration of the flash in seconds

With nitrogen iodide, Meerkämper (Ref 36) found the incident energy indirectly proportional to the time elapsing between the onset of the light flash and detonation. Therefore the relation is:

$$Et = \text{constant} = 1.35 \times 10^{-6} \text{ Jsec/cm}^2$$

Under concd ammonia solns nitrogen iodide cannot be ignited even with a very strong flash. In pure water local explosions occur, but without propagation due to the abstraction of heat. With the ammonia solns the inhibition is probably due both to cooling and to reaction with hydrogen iodide which lowers the heat liberated during the reaction

Pb styphnate and MF are two primary expls which can be initiated by light but which can show two modes of propagation. They either burn with a velocity of a few meters per sec or detonate. The min critical ignition energy for Pb styphnate monohydrate crystals covered with a quartz plate is 29 J (Ref 59). If a water filter is used the value is 31 J, showing that long infrared radiation plays little part in the initiation process; the temp rise being produced by absorption of blue or ultraviolet light emitted by the flash

The variation of the min ignition energy for Pb styphnate as a function of ambient temp was

determined to be a linear relationship (Fig 21) (Ref 56). As in Fig 20, extrapolation to zero light energy was done, but the value of about 480° is much higher than the "dark" ignition temp. With the 5-sec expln temp at 250° , the value of 480° for a time <10 μ secs is not unreasonable

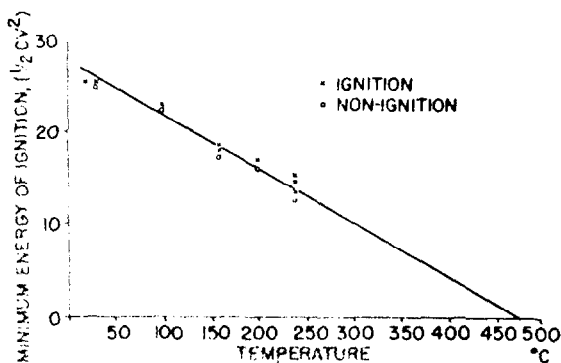

Fig 21 Variation of the Minimum Light Energy for Ignition of Lead Styphnate with Ambient Temperature (Ref 56)

Solid covalent organic azides and nitrates have not been expld by an intense light, but molten expls such as PETN can expld with sufficient light-energies. PETN ignites just above its mp if the energy of the flash is 480 J and a time duration of 20 μ secs. Prior to that, considerable decompn takes place in a thin surface layer. NG also decompn during irradiation with ultraviolet light. However, at the elevated temp of 100° it can be made to expld during a flash of 900 J. Khlevnoi et al (Ref 185) subjected NG powder with 1% lampblack to a light flux as a function of ignition time, ie, 167 J/cm^2 (40 cal/cm^2) for 30 secs. The same type of expt was conducted by Mikheev (Ref 84) with ballistite proplnt, also with 1% lampblack, with similar results

The use of spray-deposited Ag acetylide-Ag nitrate (SASN) demonstrated (Ref 202) that a detonation initiated at a point in the expl by a light from either a photographic flash bulb or a Xenon flash tube would propagate a length of a long strip. To achieve nearly simultaneous ignition, a source of light capable of imparting energy sufficient for initiation over a large surface within a very short time frame was employed successfully. This application has been

used to simulate impulse loading of structures and X-ray simulation of blow-off impulse on missiles (Refs 250-52 & 259)

The initiation of expln in condensed explosives by a laser beam has been reported by several investigators (Refs 160, 161, 168-70 & 182). Brish et al (Ref 168) used a neodymium laser in the Q-switched mode to initiate detonations in Pb azide and PETN. The expls were pressed in transparent plastic shells with a density of about 1 gm/cc. The laser output pulse had a power up to 10 MW and a length of 0.1 μ sec (energy 0.5 J) at a beam diameter of 15mm. The power density on the surface of the Pb azide reached 0.08 MW/mm^2 (energy 0.1 J), but the ignition delay varied from 10^{-8} to 10^{-4} secs, while the energy required remained constant (Ref 168). Above 10^{-4} secs, the energy increased with ignition delay (Ref 170). This effect was not observed for PETN, for which a much higher density was required

Vollrath (Ref 160) and d'Art (Ref 187) reported on the behavior of primary expls subjected to a pulsed-laser of 100 MW with neodymium-doped glass (10600\AA) emitting flashes 30 nanosecs wide. The primary expls were compressed into thin metal cups (6.5mm ID) at 1000 bars with a max energy of 3 Joules. With that energy diazodinitrophenol (DDNP) burns, K dinitrobenzofuroxan (KDNBF) deflagrates, and MF behaves erratically since it burns, deflagrates, or detonates. However, with Pb azide, Cd azide and Pb styphnate, consistent results were obtained. The data, which determined the average energy densities of the laser radiation defining the threshold at 0% and 100% functioning, is as follows:

	Average energy densities	
	No reaction (mJ/cm ²)	100% Initiation (mJ/cm ²)
Lead Azide	1.5	10
Cadmium azide	30	110
Lead styphnate	100	1200

Expts were also conducted using a ruby laser of 50 MW emitting 25 nanosecond flashes at 6943\AA . Vollrath reported that Pb. and Cd azides are less sensitive at 6943\AA than at 10600\AA , while Pb styphnate is more sensitive

At PicArsn Kessler (Ref 170) conducted expts with Q-switched and non-Q-switched ruby lasers

and found that initiation was dependent on the rate of energy application, and that expls activated by Q-switching had significantly shorter initiation times. At a distance of three feet, Pb styphnate is initiated with 0.25 J with an unfocused laser. With Pb azide, focusing was required and initiation began at 0.005 J in a focused area of .007 cm². Using a collimated laser beam system and .3 J, red safety matches were ignited at 80 ft and blue safety matches at 120 ft, showing the increased absorption of the red laser radiation by the blue surface. Dextrinated Pb azide was initiated at 250 ft

Brish et al (Ref 189) continued their expts with secondary expls including RDX and HMX, as well as Pb azide and PETN. With Pb azide the data indicates that over a broad interval of variation of the ignition lag (or initiation delay), approx from 10⁻⁸ to 10⁻⁴ secs, the energy required to expld the Pb azide is almost constant, above 10⁻⁴ secs it increases (see Meerkämper (Ref 36). This is not true for PETN

Expts have shown that the laser radiation density or flux does increase with the density of the pressed expl pellets

An evaluation was made by Brish (Ref 189) to determine the mechanism of initiation as a result of the action of laser radiation. Shock caused by the pressure of the light, electrical breakdown, photochemical initiation, and thermal initiation were the processes studied, and an analysis of the exptl results for Pb azide and PETN from the standpoint of those physical processes indicated that only the thermal theory of initiation can explain the data. In this case the light energy is absorbed by a layer of the expl and converted into shock-wave energy, which initiates the expls

Other investigators (Refs 161, 169, 183, 195, 204, 206, 207 & 213) have investigated the initiation of expls by laser radiation with the emphasis on secondary expls. With direct initiation of secondary expls, ie, by incorporating a fiber optic (Ref 225), primary expls become unnecessary, thus providing increased safety and reliability in expl trains

3 Radiation Effects on Propellants and Propulsion

Neutron Irradiation

In surveying the literature on the subject of

nuclear radiation effects on solid propellant material one finds that, although the effect of radiation is primarily one of ionization, the amount of work performed on proplnts with neutrons alone has been very minimal. The majority of the lab work has been done with reactor and gamma irradiations. To clarify it further, the reactor irradiations did not start until the early 1960's while the gamma irradiations were being conducted since 1950

a) Reactor Irradiations

Steady State

One of the first published reports on reactor-irradiated propellant materials was the work of Hennig et al (Ref 31) in 1953, who irradiated Na nitrate, K nitrate, and K chlorate in the Argonne Heavy Water Pile in vacuum and air. The evolution of gas, trapped oxygen and change in color of the crystals were recorded. The exptl thimble was used with the slow neutron flux about 10¹² n/cm²-sec with the fast flux about one-tenth of that for a period of 2-4 weeks. The γ -component was not given

In a program to develop a nuclear low altitude supersonic vehicle (LASV-N), off-the-shelf propellant materials were irradiated in excess of the design and test goal of 10¹⁶ n/cm² (E > 0.3 MeV) and 3 x 10⁷ R (Ref 142). BlkPdr, RDX-Hycar and HMX-Hycar were subjected to nuclear radiation levels ranging from 5 x 10¹⁵ to 8 x 10¹⁶ n/cm² and 10⁸ to 10⁹ R. The results indicated that none of these materials would meet the design specifications after sustaining the LASV-N anticipated doses

In a program for the Air Force, Frankford Ars (Refs 87 & 103) irradiated single base (M10), double base (M5) and composite (HES 5808.1) proplnts which were utilized in standard propellant actuated devices in high speed emergency aircraft escape systems. The proplnts, in equivalent volume cartridges, were exposed to an integrated dose of neutrons and gamma radiation in the range of 10¹³ to 10¹⁵ n/cm² and 10⁶ to 10⁸ R, respectively. BlkPdr was also irradiated. Results indicated that marked physical, chemical and ballistic changes occurred at the highest level

The practical value of a solid rocket propellant is largely determined by the amount of heat released during combustion to exhaust products. Coughlin and Tsukimura (Ref 177) conducted a

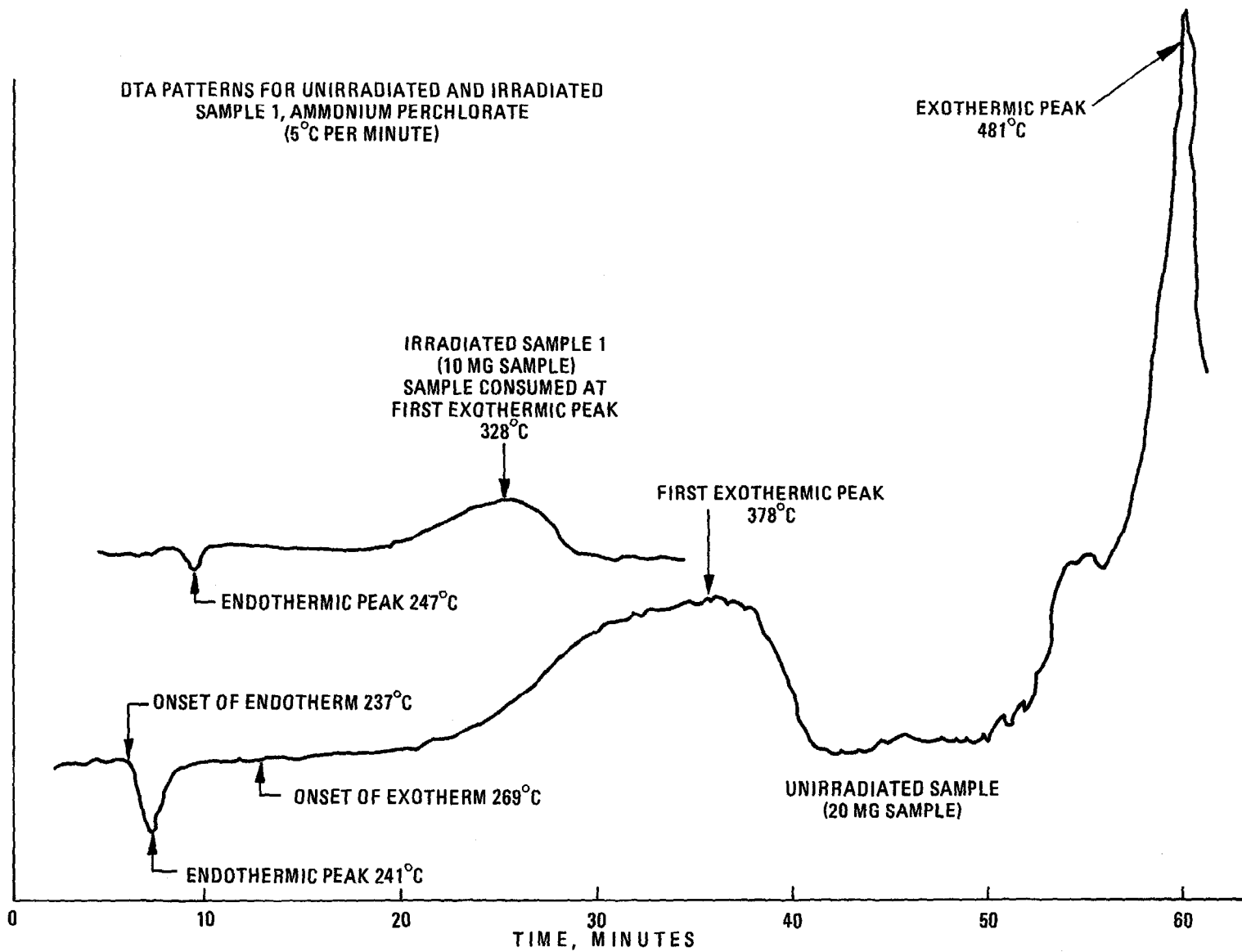

Fig 21 DTA of Ammonium Perchlorate Showing Effect of Reactor Irradiation (10^7 n/cm², 1.7×10^8 R) (Ref 177)

program to create permanent deformations in the lattice of a proplnt material, and then by calorimetric methods tried to demonstrate the amount of extra energy available as heat during combustion

Four samples of reagent grade amm perchlorate weighing five grams each were irradiated in the Aerojet-General Nuclear Industrial Reactor (AGNIR) for periods of 37, 78, 187 and 224 hours. Total radiation exposures ranged from 1.0×10^{17} to 6.1×10^{17} n/cm² (E > 1.0 MeV) and from 1.7×10^8 to 9.9×10^8 R

Sample decompns were found to be proportional to total radiation exposure. In the expt of longest duration, 36.5 weight percent of the irradiated sample decompd into gaseous decompn products and generated a gas pressure of 19.5 atmospheres in the sealed irradiation pressure vessel. Only 1.5 grams, or 30% of the original sample, was recovered in useable form

The crystalline samples recovered for analytical and calorimetric measurements all showed excessive radiation damage with extremely porous structures and acidic residues. The effect of the 10^{17} n/cm² and 1.7×10^8 R gamma is shown in the DTA thermogram in Fig 22. Measured heats of soln ranged from +68.04 cal/g for the unirradiated sample to a min of -34.70 cal/g for the sample of 187 hours exposure. Correspondingly derived values of apparent energy storage ranged from 13.02 cal/g for the 37 hour exposure to a max of 102.74 cal/g for the 187 hour exposure sample

Comparison of measured heats of soln with estimated heats of soln based on chemical analyses of the samples indicated that the derived values of apparent lattice energy could be accounted for on the basis of changes in chemical compn alone, particularly the accumulation of free perchloric acid in the irradiated samples

It is concluded that under the exptl conditions of this study in which the irradiated sample was continually exposed to water and other products of radiolytic decompn, no lattice energy was stored. The mechanism by which the initially induced lattice energy storage was lost is believed to be, not thermal annealing, but rather recrystallization due to contact with water formed by partial sample decompn

In the extensive study on the NERVA program, Avrami and Voreck (Ref 192) reported on

eleven proplnts covering a wide range of compds. In this program it was found that proplnts compounded from high-temp and radiation-stable expls and a plastic binder have a good radiation stability if the binder is also stable. A list of the composite proplnts showing the effects of reactor irradiation is shown in Table 18. The most radiation-stable proplnt tested in that program combined one of the best radiation resistant expls (DATB) with a binder. This was IB 7158 (75% DATB with 25% polystyrene-butadiene co-polymer) and it was subjected to a max total dose of 4.3×10^{17} n/cm² fast, 1.7×10^{18} n/cm² thermal and 4.5×10^9 R for a 10 hr exposure

Fluorocarbons, such as Viton, degrade the radiation stability of a proplnt compd, even though they have good thermal stability. The composite proplnts containing K perchlorate had high temp stability, but this applicability was limited by relatively poor radiation stability, as shown in Fig 22, due primarily to the high thermal-neutron cross section of chlorine (33.6 barns)

The radiation-stable expls lack the high oxygen content found in proplnt additives and therefore give rise to low specific impulses when used in proplnt compns. If this cannot be tolerated, the use of K nitrate as an oxidizer with a polystyrene-butadiene binder should result in a very radiation-stable proplnt because of its high radiation stability, as shown by the tests on BlkPdr (Ref 167)

Amm perchlorate (AP) in ANP-3095 proplnt has about the same radiation stability as K perchlorate, which indicates that the ClO₄ radical is the controlling factor in both compds. Although proplnts containing AP have higher specific impulses than those with K perchlorate, their temp stabilities are lower. If temps do not exceed 150°, ANP-3095 proplnt provides adequate radiation stability and a high specific impulse. NC, being very susceptible to radiation, limits the use of the conventional single-, double-, and triple-based gun proplnts, M-6, T-28, and T-36, to applications involving low temp and low radiation exposure. This is shown by the weight loss in Fig 23

Zakharov et al (Ref 188) reported on the effect of prior irradiation with X-rays, protons and neutrons on the thermal decompn of AP.

Table 18
Effects of Reactor Irradiation on Some Composite Propellants (Ref 192)

Irradiation time min	Total dosages ^a		Gamma R	Weight loss %	10% Wt loss on TGA °C	Vst@200°C Avg gas evol cc/g/hr	DTA Exotherm @20°C/min °C	DTA Endotherm @20°C/min °C	5-sec Expl temp °C	Strand Burning rate in/sec	Melting point °C
	Fast neutrons n/cm ²	Thermal neutrons n/cm ²									
A. IB7158 (75/25 DATB/PSB); see (a.) below											
0	—	—	—	—	290	0.49	340	277	387	0.741 ^b	277
60	5.04x10 ¹⁶	3.24x10 ¹⁷	4.2x10 ⁸	0.88(0.64)	265	10.13	345	278	383	0.735	278
60	4.30x10 ¹⁶	6.32x10 ¹⁷	4.6x10 ⁸	0.96(0.52)	272	2.96	344	275	368	—	275
120	8.06x10 ¹⁶	6.00x10 ¹⁷	8.0x10 ⁸	1.06(1.06)	270	6.88	335	273	378	0.806	273
600	43.00x10 ¹⁶	17.00x10 ¹⁷	45.0x10 ⁸	13.10(5.62)	259	11.03	318	265	284	—	265
B. PPLA (75/25 DATB/Viton A)											
0	—	—	—	—	290	0.68	353	278	388	0.242 ^c	278
60	5.0x10 ¹⁶	2.9x10 ¹⁷	4.0x10 ⁸	1.70(1.08)	271	4.68	351	273	277	0.063	273
60 ^d	4.7x10 ¹⁶	2.7x10 ¹⁷	4.7x10 ⁸	2.64(1.52)	263	3.04	350	274	267	0.067	274
121	9.4x10 ¹⁶	5.9x10 ¹⁷	8.0x10 ⁸	3.80(1.21)	237	7.03	343	273	366	0.095	273
216	16.8x10 ¹⁶	10.1x10 ¹⁷	16.6x10 ⁸	8.27(6.9)	224	11.00	333	270	313	0.067	270
C. AK-14 Mod I (KClO ₄ /PES)											
0	—	—	—	—	368	.008	495(398)	298	406	0.84 ^e	—
36	2.76x10 ¹⁶	2.0x10 ¹⁷	2.5x10 ⁸	0.254	—	3.92 ^f	487	295	313	—	—
60	5.40x10 ¹⁶	3.0x10 ¹⁷	4.2x10 ⁸	2.50(2.61)	311	6.43	490(375)	305	281	1.25	—
60	4.30x10 ¹⁶	2.5x10 ¹⁷	4.5x10 ⁸	1.24(1.29)	307	6.11	490(365)	295	271	1.14	—
120	10.00x10 ¹⁶	5.7x10 ¹⁷	8.4x10 ⁸	8.54(6.80)	307	3.08	475(435)	302	300	3.08	—
123	9.48x10 ¹⁶	6.6x10 ¹⁷	8.4x10 ⁸	8.05	—	0.62 ^g	468	298	319	—	—
(a.) 3.6 grams of powder and strand in capsule in KIWI-TNT (pulse)											
~1Msec	7.0x10 ¹³	2.4x10 ¹⁴	3.0x10 ⁶	0.067	—	0.22	475(398)	294	545	4.80 ^g	—
~1Msec	35.0x10 ¹³	17.0x10 ¹⁴	1.5x10 ⁷	—	—	0.24	490(383)	294	487	4.82	—

R 56

Table 18 (Cont'd)

Irradiation time min	Total dosages ^a		Gamma R	Weight loss %	10% Wt loss on TGA °C	Vst@200°C Avg gas evol cc/g/hr	DTA Exotherm @20°C/min °C	DTA Endotherm @20°C/min °C	5-sec Expl temp °C	Strand Burning rate in/sec	Melting point °C
	Fast neutrons n/cm ²	Thermal neutrons n/cm ²									
D. HES 6573 (KClO ₄ /Acrylic)											
0	—	—	—	—	331	0.465	352	293	408	1.54 ^e	—
120	9.36x10 ¹⁶	5.7x10 ¹⁷	8.4x10 ⁸	6.01	285	16.3	230 ^g	302	260	h	—
E. IB7169 (KClO ₄ /PS)											
0	—	—	—	6.01	397	0.38	435	292	593	0.95 ^e	—
120	9.36x10 ¹⁶	5.5x10 ¹⁷	8.4x10 ⁸	7.72 ^f	351	1.42	355 ^g	310 ^d	376	h	—
F. ANP 3095 (AP/Al/PV)											
0	—	—	—	—	—	0.15	260(327)	235	317	—	—
25	2.2x10 ¹⁶	1.1x10 ¹⁷	1.9x10 ⁸	1.00	—	—	—	—	—	—	—
128	9.0x10 ¹⁶	6.6x10 ¹⁷	7.9x10 ⁸	5.64	—	3.27	285(333)	233	159	—	—

^a Average reactor exposure rates: fast neutrons $\phi > 0.18$ MeV - 1.4×10^{13} n/cm²-sec; thermal neutron $\phi > 0.17$ ev - 8.6×10^{13} n/cm²-sec; gamma 4.0×10^8 R/hr (3.38×10^{10} ergs/gm(C)/hr gamma)

^b Strands burned at 35,000 psig

^c Strands burned at 1500 psig

^d Tested 112 days after irradiation

^e Strands burned at 1000 psig

^f VST @ 150°

^g Strands burned at 20,000 psig

^h Strands crumbled

**RADIATION STABILITY
(EXPOSURE TO PRODUCE 5% WT LOSS)**

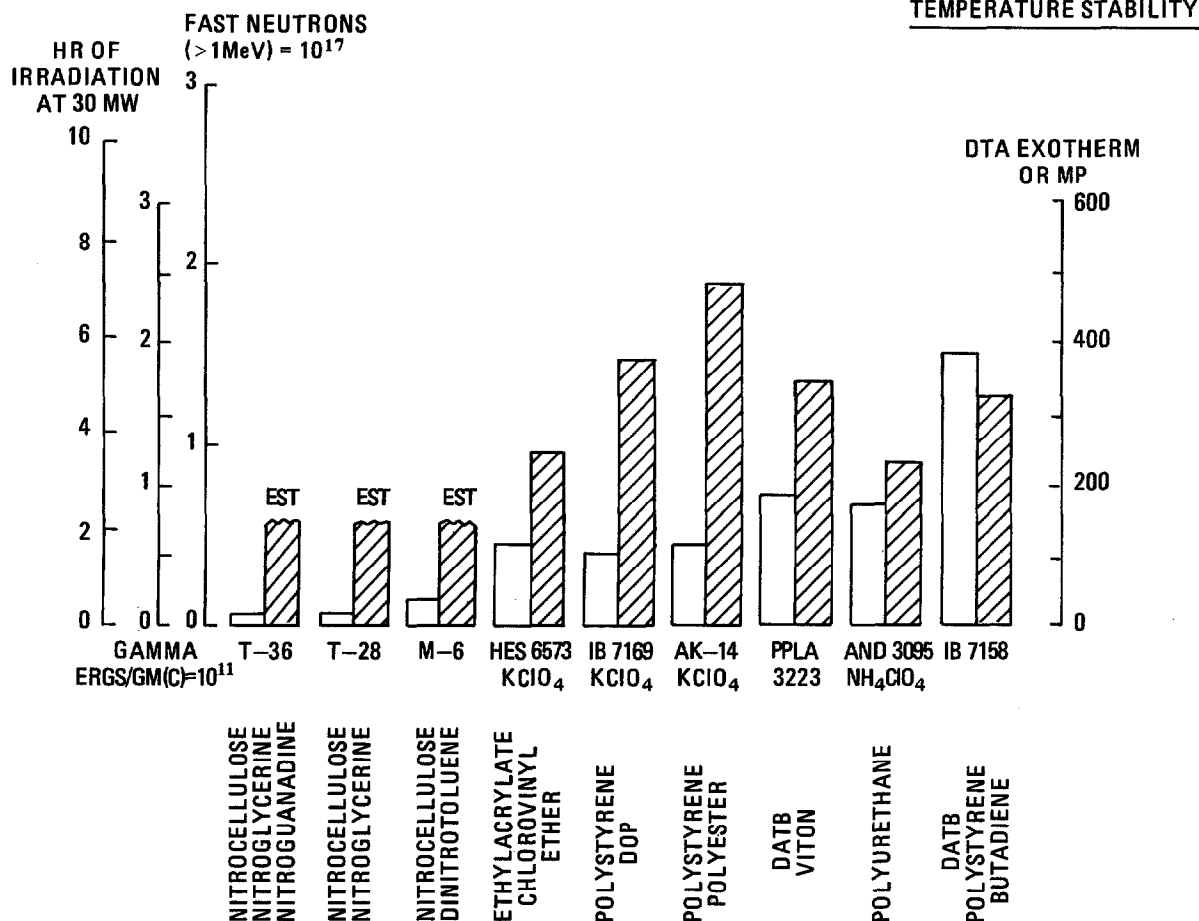

Fig 22 Relative Radiation Stability of Propellants (Ref 192)

The neutrons were obtained from the reactor ${}^4_9\text{B}^9(d,n){}_5\text{B}^{10}$ and the decompn was studied by DTA. An increase in the rate of decompn was observed by all the forms of radiation mentioned up to doses of 10^{19} eV/g ($1.14\text{R} = 6.24 \times 10^{13}$ eV/g). About 10^{20} eVg ($\sim 5 \times 10^7 \text{R}$) caused the salt to decomp before the modified transition ($\sim 235^\circ$). The conclusion was made that the acceleration of the decompn was due to the presence of radiolysis products

Levy, Herley and co-workers at Brookhaven National Laboratory have been studying the effects of X-ray, gamma rays and neutron radiations on AP (Refs 163, 208, 211, 224, 228, 240, 241, 244, 255 & 258). Neutron effects studies

were conducted on AP single crystals, powder, and 93/7 AP/Al powder. The mixts were in powder and pellet form with the particle size of the Al about 18 microns. Previous studies on radiation damage in AP produced by steady-state X-rays and gamma ray irradiation (this will be discussed in steady-state gamma irradiation of proplnts) were extended to include fission and 14 MeV neutron irradiations. Quantitative damage versus dose were obtained from thermal decompn studies. The latest measurements indicate that fission neutrons, gamma rays and X-rays produce roughly equivalent radiation damage effects. Neutron irradiations shorten the thermal decompn induction period, increase

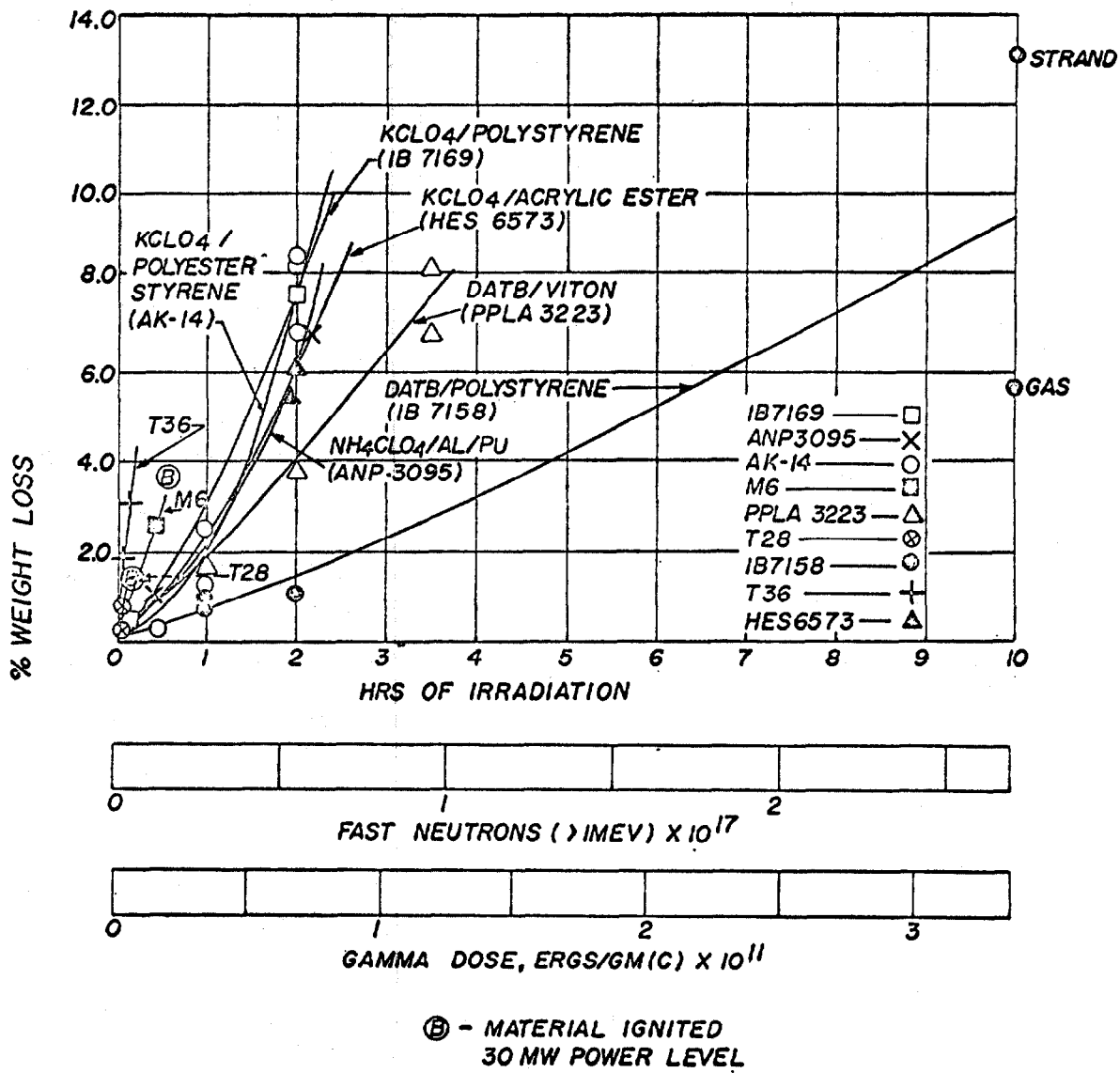

Fig 23 Weight Loss of Propellants as a Function of Reactor Irradiation (Ref 192)

the acceleratory period rate constant and increase slightly, or not at all, the decay period rate constants. However, one set of data exhibits effects about ten times the damage, on an equal energy deposition basis, to gamma-ray damage. This has not been resolved. Also data from 14 MeV neutron irradiation, at four flux levels, indicates that these particles produce copious radiation damage effects (fracturing and highly strained). Also data from pellets made of AP powder and from AP/Al mixts exposed to continuous gamma ray or fission neutron irradiations, or a neutron irradiation followed by a gamma ray irradiation, exhibit similar increases in the thermal decompn rate constants. The fission neutron fluences ranged from 5.0×10^{11} to 1.14×10^{12} n/cm² with a very small gamma component. The 14 MeV total dose ranged from 5.5×10^{13} to 2.0×10^{16} n/cm². For the mixts the total dose was 10^9 – 10^{10} n/cm²

Pulsed Reactor

A search of the literature has revealed that the number of pulsed reactor irradiations of proplnts is minimal when compared to the number to steady-state reactor and steady-state gamma irradiations

Among the first expts in which the effect of pulsed reactor radiation was attempted on any proplnt was the KIWI-TNT transient excursion test in the NERVA program (Refs 159 & 192). As reported by Avrami and Voreck (Ref 192), the only proplnt in that test was AK-14 Mod I which is a cast, fuel-oxidizer whose compn is 74% K perchlorate, 25% polyester-styrene copolymer (P-10 resin) and 1% carbon black. Two capsules were irradiated at two levels – the lower level at 7.0×10^{13} n/cm² fast, 2.4×10^{14} n/cm² thermal and 3×10^6 R gamma, and the higher level at 3.5×10^{14} n/cm² fast, 1.7×10^{15} n/cm² thermal and 1.5×10^7 R gamma – all in a pulse of about one millisecond. The tests conducted on the AK-14 Mod I proplnt did not show any significant changes although the 5-second expln temp results were not consistent with the control and steady-state results

A series of tests were conducted by the Ballistic Research Laboratory at the APRFR which ranged from developing techniques and methods of irradiating burning miniature rocket motors and strand burners from outside to inside the reactor core (in the "glory" hole) (Refs

215, 216, 220, 229, 234, 235, 237–39, 245 & 246). The neutron dose increased from 10^{12} n/cm² to 3×10^{14} n/cm² in the glory hole. SPRINT-type solid rocket proplnts containing NC, NG, AP, HMX and Al were irradiated without any effects in strand burner and motor burning configurations taking into consideration the safety features required for this type of expt

Hutchinson (Refs 230 & 242) used the same facility to irradiate a proplnt, ARCADENE 242A, which consists of 55.0% AP, 29.736% prepolymer HX-730, 5.0% oxamide, 1.0% catocene, 1.0% carbon black and other ingredients. Miniature operating motors with the proplnt were pulsed irradiated, about 50 μ secs in duration, in excess of 10^{14} n/cm². The mini-motors, operating at chamber pressures from 2500 to 300 psi, showed at the highest dose of 4.6×10^{14} n/cm² an average chamber pressure increase of 20%, which corresponds to a burn rate increase of about 7%. Ward and Rocchio (Refs 234, 238, 245 & 246) irradiated AP at 4×10^{14} n/cm² and the kinetics of vaporization were studied by isothermal thermogravimetry; the results indicate that there was no effect on the rate of vaporization which in turn implies that the combustion rate would not be affected. This is in contrast to previous results (Refs 224, 240 & 241) on the rate of the low temp decompn of AP, where various types of radiation shorten the induction period and increase the accelerating period. On this basis the indication is that neutron radiation will have no influence on the rate of combustion of pure AP or pre-irradiated AP incorporated into a composite proplnt. It also suggests that the increase in the burn rate observed by Hutchinson (Refs 230 & 242) is the result of neutron damage to the binder. However, based on the inconsistencies of similar materials irradiated at the same fluence in the same reactor, it appears that more expts will be needed to demonstrate conclusively whether neutron radiations can alter combustion properties of AP composite proplnts

b) **Gamma Irradiation of Propellants and Propulsion**

Steady-State

The amount of work performed on the gamma irradiation of proplnts has been voluminous starting with the Oak Ridge-PicArns

studies (Refs 26, 37, 51, 53 & 58) in the early 1950's on gamma effects on expls and proplnts

Pure NG decompd under gamma radiation at ambient temp and produced 11.5 ml of gas/gm after 5×10^7 R. The decompn gases corroded Hg, an action that was not observed with the other expls tested. The irradiated residue was very viscous, evolving fumes of nitrogen dioxide. After standing for 50 days, it became almost solid. No further work was conducted because of this severe deterioration

A double-base propellant, Ballistite (69.25 NC, 30.30 NG, 0.25% diphenylamine), evolved 2.8 ml of gas/gm after 3.4×10^7 R gamma exposure. The decompn rate of Ballistite increased very rapidly with the exposure rate. NG probably contributed to the poor radiation stability of this material

The M15 proplnt (54.7 NGu, 20.0 NC, 19.0 NG, 6.0 ethyl centralite and 0.3% eryolite) released 3.35 ml of gas/cm after an exposure of 5.4×10^7 R. Here also the chief source of gas evolution was probably NG. The rate of gas formation of the M15 proplnt did not increase as rapidly as that in Ballistite

From 1956 to 1960 a series of expts were conducted by the US Naval Propellant Plant, Indian Head, Md, to study the effects of Co^{60} gamma radiation on NC and double-base proplnts (Refs 43, 47, 55, 76, 77 & 85)

Dried uncolloided NC received $1-11 \times 10^6$ R at a gamma dose rate of 5.6×10^5 R/hr. The nitrogen content decreased only about 1% by weight. However, intrinsic viscosity, which is determined in solns of acetone, was reduced to one third of its initial value. This instability is typical of the cellulosic polymer and is attributed to bond breakage (Ref 47)

Strips of JPN proplnt, containing 51.4 weight percent NC, 42.9 NG, 3.23 diethyl phthalate, 1.25 K sulfate, 1.00 ethyl centralite, 0.2 carbon black, and 0.02 candelilla wax, were exposed to total doses of 1 to 5×10^6 R at a dose rate of 1.93×10^5 R/hr at Co^{60} sources at Brookhaven National Laboratory. Significant changes were observed in the viscosity of NC, the available centralite stabilizer, and the stability of the proplnt. Viscosity measurements indicated the degradation of the NC polymer chains. The highest dose sample was approx comparable in stability to a similar proplnt produced by an

accelerated aging treatment of 20 days at 80° . Although no changes occurred in the closed-bomb, strand-burning, and heat of expln tests, the tensile strength and elongation decreased as the dosage increased (Ref 43)

Owyang and Williams (Ref 55) subjected OGK double-base proplnt to Co^{60} gamma radiation to total doses up to 15×10^6 R. The tensile strength, elongation, and work to produce max stress all decreased with increase in dosage

Further irradiations were performed with the cast double-base proplnts ARP, ALL, and AHH, and the aluminized composite CDT (Refs 76, 77 & 85) at higher dosages (3.82×10^7 R) than OGK proplnt to provide further data on the extent of degradation. Gas evolved between $2.4-3.1 \times 10^7$ R causing blisters. At the max dosage marked deterioration occurred in the tensile strength, elongation, and work to produce max stress. By the Taliani test these materials had reached the end of their safe life

Opening a new approach to proplnt manufacture, Aerojet-General in 1958 demonstrated the curing of solid proplnts by gamma radiation. Carleton et al (Refs 65 & 81) showed that, by using a Co^{60} source giving a dose rate of about 1.4×10^5 R/hr, typical castable proplnts containing AP, AN and K perchlorate were cured at ambient temp. The advantages of the method are shorter cure times and elimination of temp changes during manufacture

A study of the gamma radiation effects on polysulfide proplnts (Refs 67 & 68) was undertaken at Thiokol Company in 1958 using two standard proplnts containing AP-polysulfide, Type TED-505, and AN-polysulfide, Type TEX-402. Gamma exposure of 5×10^6 R caused only small changes in physical properties and burning rates. At the 2.5×10^7 R level, the changes became quite apparent and increased rather rapidly with increasing dosage. After 7.5×10^7 R changes in density, stress, strain, modulus of elasticity and burning rate became quite significant. Also, in part of the program pure AP and AN crystals were irradiated to a total dose of 5.0×10^7 R, with no changes detected in the infrared spectra

As stated previously, the effect of radiation, be it neutrons, gammas, protons, etc, on the solid proplnt or liner materials, is primarily one of ionization, resulting in the production of

chemically active species, mostly free radicals and ions. These species can initiate a number of different types of chemical reactions in a material depending on the chemical structure of the material. In polymers the two general types of chemical changes are cross-linking and bond scission. Polymeric materials, such as those used in binders in proplnts and for Fiberglas wound cases have degradation thresholds in the range of 10^5 – 10^9 R

It should be noted that while irradiation leads to cross-linking in some polymers, it leads to chain-scission in others. Both of these effects may occur simultaneously but one generally predominates. Increased cross-linking leads to increased tensile strength and reduced elongation at break, decreased solubility, etc. Cross-linking ultimately leads to an extremely brittle and fragile substance with very little mechanical strength. Chain scission has the opposite effect of cross-linking. Chain-scission leads to a low molecular weight material with no mechanical strength. At sufficiently high doses both processes are deleterious

Haley (Ref 86) reported on the effect of gamma radiation in the chemical and physical properties of TP-H-8009 proplnt which consisted of AP/polybutadiene-acrylic acid/Al. This Minuteman proplnt is stable up to 2.5×10^7 R. In this dose range, no significant losses were observed. However, beyond this range, the proplnt was unable to survive the initial pressure buildup in a rocket engine; consequently ballistic failure occurred

Extensive cross-linking was indicated as being the principal reaction occurring within the PBAA vulcanizate at large dose levels, although there is some evidence that chain scission occurred to a small extent. The effects produced in the physical properties are irreversible and are dependent upon the total dose

Freeman et al (Ref 78) reported on the effect of X-rays and gamma rays on the chemical reactivity of AP with respect to thermal decompn. The effect was shown by DTA and TGA tests under ambient and reduced pressures. The low temp stages of reaction are affected by pre-irradiation. It was suggested that the increased reactivity was due to the presence of positive holes which would indicate an electron transfer

mechanism of decompn. The use of impurities such as Ag^+ , Cu^{++} and I^- seem to support this theory. Also it was found that the decompn of the gamma-irradiated samples is similar to that of X-ray irradiated AP. The samples were irradiated with the Brookhaven National Laboratory Co^{60} source at a rate of 1.0×10^6 R/hr for 1/2 hour and 24 hours

Allen et al (Ref 124) conducted a study on two proplnt formulations by using Co^{60} gamma rays to simulate the radiation effects which would be encountered in space. Polybutadiene-acrylic acid proplnt and polyurethane proplnt, based on toluene diisocyanate, were subjected to total gamma doses of 10^7 R in air and vacuum since an absorbed dose of 10^6 R/yr was accepted as the largest natural exposure which might be encountered in space. The effects on auto-ignition, burning rates and mechanical properties were studied. While some mechanical properties showed some real changes, they are not considered significant for an effect in performance. Other investigators (Refs 101 & 120) studied the Minuteman and Dyna Soar proplnts (TP-H-1011 and TP-11-1050), and stated that in most cases gamma dose levels of greater than 2×10^7 R are required to cause serious effects in proplnt properties. This agrees with Fink (Ref 90) who stated that with the threshold criteria for proplnts being gassing, the threshold range was 1.0×10^8 – 8×10^9 erg/g (c) (1.14×10^6 – 9.1×10^7 R)

Additional work was performed by Gardner (Refs 92 & 99) on proplnts for future missions in space. A PBAA AP/Al proplnt, an aluminized double-base proplnt, and a polyurethane-AP/Al proplnt were studied as a function of Co^{60} radiation, with a dose rate of 2.54×10^5 R/hr and total doses ranging up to 1.5×10^7 R. The effects were noted on tests with the burning rate, tensile stress, elongation modules and hardness of the three materials. The PBAA proplnt withstood 1.5×10^7 R. On the tensile strength, the double base and polyurethane decrease significantly at a dose of 4×10^6 R. On elongation, the double base decreased on stress at max strain after 10^6 R, while the polyurethane proplnt decreased on modulus and hardness after a dose of 10^6 R. Estimates of the radiation effects on polymers are listed in Table 19

Table 19
Estimates of Radiation Effects on Polymers
(Ref 99)

	Threshold dose, rad ^a	Usable dose, rad ^b
Polyurethane	10 ⁶	8x10 ⁶
Polyvinyl chloride	10 ⁷	10 ⁶
Polybutadiene-acrylic acid copolymer	10 ⁶	10 ⁷
Polysulfide rubber	5x10 ⁶	5x10 ⁶
Polysulfide rubber plus phenolic resins	10 ⁶	5x10 ⁷
Cellulose acetate	10 ⁶	10 ⁷

^a Lowest dose at which change in some physical property has been noted

^b Maximum dose at which materials will still function for limited applications

Odian et al (Refs 113, 133 & 150) showed that the deflagration rates of many composite AP solid proplnts were affected by gamma doses of 5×10^7 R. Two polysulfide-based proplnts (Thiokol TP-L-3014 and TP-L-3014a) showed rate decreases, polyurethane (Thiokol TP-6-3129), polyacrylate (Hercules HES-6420) and polyacrylonitrile (HES-6648) based proplnts showed increases, while hydrocarbon (Thiokol TP-H-3062) and cellulose acetate (Hercules HES-5808) proplnts showed no changes in deflagration rate. Since the composite proplnt formulations contain various additives besides the binder and oxidizer, an effort was made to determine the effect of radiation on the deflagration rates of binder and oxidizer separately and independent of additives

In a methane environment, with a total dose of 1×10^8 R the irradiation of AP results in an increase in the acceleration of its burning rate. With polystyrene, the rate decreases and mixts of AP/polystyrene in which the AP was irradiated, an increase did occur

Piantanida and Piazzi (Refs 100 & 115) conducted expts on expls and proplnts which had been subjected to γ -ray irradiation. Proplnts containing 0–7% diethylphenylurea and 0–5% Bu phthalate were irradiated with Co⁶⁰ gamma rays with total doses ranging from 3–15 x 10⁶ R with a dose rate of 10⁴ R/hr, 1 x 10⁶ R at 600

R/hr, and 10R with 180 day aging. The thermal stability was determined by the Taliani method, by which the time is measured for a standard volume of gas to evolve. In all cases the stability decreased. The effect varied inversely with the diethylphenylurea content. Proplnts containing this material turned green upon irradiation

The stability of NC and NG (Ref 115) was determined in comparison with that of PETN when irradiated with Co⁶⁰ gamma rays and the influence of stabilizing additives (ethyl centralite) on the stability was studied. Proplnt samples containing NC and NG (BST), NC and 35% dinitroglycol (DNG), and NG with 1,3, and 5% ethyl centralite were exposed to Co⁶⁰ at rates of 3×10^4 R/hr for total doses of 1–10 x 10⁶ R. The exposure varied from 33 to 330 hours. Stability after irradiation of unprotected proplnt (BST and DNG) was higher than that for PETN. The protective effects of ethyl centralite against thermal attack and gamma rays were demonstrated for proplnts containing at least 1% of ethyl centralite

Further expts were conducted on candidate proplnts for space environments. Horton (Ref 112) subjected a urethane-based proplnt, a polybutadiene-acrylic acid-acrylonitrile based proplnt, and a carboxyl-terminated polybutadiene based proplnt to 1.5×10^7 R, as well as to high and low temp and pressure. The data indicated that the urethane proplnt withstood the tests best. Scott et al (Ref 126) conducted tests on two polycarbutene solid proplnts which were irradiated to 10⁷ R and subjected to high vacuum exposure as a function of temp without much change

On the other hand, San Miguel and Duran (Ref 125) showed that the mechanical properties of polyurethane solid proplnt were degraded significantly by gamma irradiation dosages greater than 10⁶ R. The tests used to determine the effects were by swelling, torsion, uniaxial tension and multiaxial tension

Abel et al (Ref 136) conducted a study to determine the effects of gamma radiation on M1 single-base proplnt in order to assess limitations on its use in space vehicles or weapons exposed to radiation. Samples of M1 proplnt, which consists of 85% NC, 10% dinitrotoluene, 5% dibutylphthalate, and 1% diphenylamine, were exposed to 10⁵, 10⁶, and 10⁷ R of Co⁶⁰ gamma

rays. Although visible and chemical deterioration occurred, the burning rate was not affected. However, severe deterioration occurred at 5×10^8 R which was shown by severe blistering, swelling, and contraction, and embrittlement causing fractures

An interesting expt was conducted on proplnts by Flanagan and Gray (Ref 162), which differed from those which used gamma irradiation for curing, sterilization and environmental testing. In an attempt to separate binder-oxidizer interactions, composite solid proplnts containing preirradiated AP (2.5×10^7 R) were formulated and tested. Burning rates increased and the pressure exponent increased for polybutadiene proplnts, both metalized and un-

metalized, but the exponent decreased in the polysulfide formulation. However, the heats of explosion were reduced slightly with proplnts containing the irradiated AP

Herley, Levy and co-workers (Refs 208, 211, 224, 228, 240, 241, 244, 255 & 258) have subjected AP in all forms to various types of radiation. AP in small and large crystal form, powder, and powder-Al mixts have been exposed to gamma rays, X-rays, fast neutrons, and fast neutrons followed by a gamma-ray irradiation. In all cases the effects are determined by changes in the thermal decompn kinetics in the temp range of $193-238^\circ$. The various types of radiation on AP crystals, as determined from thermal decompn and optical and electron microscope

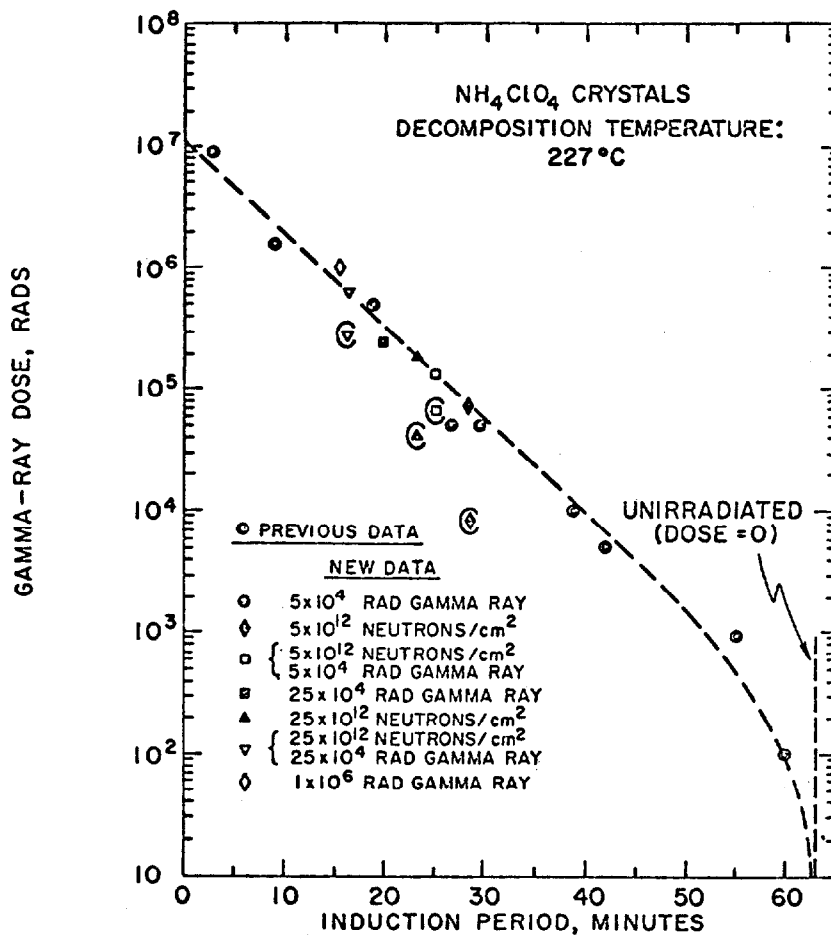

Fig 24 Induction Period vs Total Dose Data for Irradiated and Unirradiated Ammonium Perchlorate Single Crystals Thermally Decomposed at 227° (Ref 224)

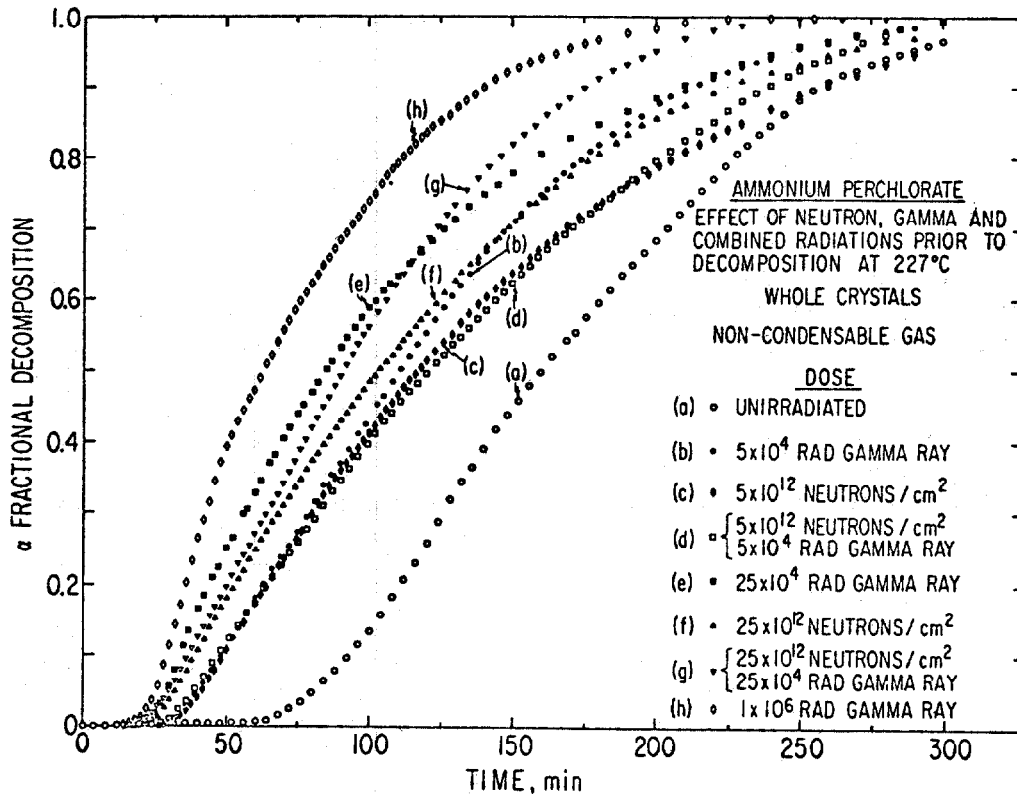

Fig 25 The Effects of Gamma-Ray ^{235}U Fission Spectrum Neutron, and Combined Gamma-Ray and Neutron Irradiation on Whole Crystals of Ammonium Perchlorate Thermally Decomposed at 227° (Ref 224)

studies all produce the following quantitative effects. As the dose is increased, the thermal induction period is shortened (Fig 24), the acceleratory period rate constant is increased and the decay period rate constants increase slightly or not at all, as shown in Fig 25. When the dose is in the region of 10^5 rad or larger the crystals begin to show indications of strain, voids are formed in the interior, and at slightly higher doses the crystals fracture on cleavage planes

Gamma-ray and X-ray induced changes increased with increasing dose and appeared to be independent of dose rate in the range 10^3 to 10^6 rad. This is an interesting result and could arise if all the radiation induced species are very short-lived. Also it suggests that the transition from dose rate independent to dose rate dependent behavior could occur quite abruptly as the dose rate is increased

Further work (Refs 244 & 255) on the thermal decompn of AP crystals and powders during gamma-ray irradiation brought forth the following effect. When previously unirradiated AP crystals are simultaneously heated and subjected to Co^{60} irradiation, the acceleratory and decay periods are altered, but not drastically. However, a marked decrease in the induction period was observed. The bursts of gas being evolved was a very interesting feature. In fact, the dose accumulated at the end of the induction period was about 30 times less than the dose required to achieve the same reduction of the sample as first irradiated and then thermally decompd. Thus, simultaneously heating and irradiating produced a large synergistic effect. The implication is that proplnts and pyrotechnics, especially those containing AP, may be sensitive to radiation during burning

New insights on the thermal decompn of large irradiated AP crystals (Ref 255) were obtained with crystals larger than 2 or 3mm. It seems that the Avrami-Erofeyev kinetics apply to the powder and small crystal forms of AP, but with large crystals the kinetics must be reexamined. First, the retentions are larger than 70% since the reaction is confined to the c-face and only part of the m-face of the crystal. Second, the decompn is surface-related. Below 2×10^4 R, irradiation does not produce any observable effects. Between 2×10^4 and 10^6 R, the crystals are transparent after irradiation but become translucent after heating. After 10^6 R irradiation the crystals appear milky but are opaque, at 2×10^7 R extensive pitting occurs, and after 5×10^7 R the crystals contain numerous voids

Pulsed Reactor Irradiation

A search of the literature has revealed that the amount of work related to the pulsed gamma-ray irradiation of proplnts and propulsion components has been minimal. Usually the gamma component in pulsed reactor irradiations are the values considered, but practically no work has been done on pulsed gamma-ray effects

d) Underground Testing (UGT) of Propellants and Propulsion

Most of the UGT expts with proplnts and propulsion components have been in an X-ray environment which actually is a mixt of X-rays and neutrons

Winnerling (Refs 62 & 76) exposed OIO and ARP double-base proplnts to radiation from a nuclear detonation placed at various distances from ground zero. The event was not identified but occurred prior to November 1957. No changes were found in the mechanical, burning or stability properties. A decrease was found in viscosity of NC in the OIO proplnt sample located closest to ground zero. Marciniak and Phillips (Ref 76) conducted steady-state gamma irradiations on ARP proplnt and found deleterious effects at 2.5×10^7 R

Woodruff (Ref 190) reported that a Minute-man II Stage III CY1-1 double-base proplnt had withstood two levels of nuclear radiation (type of radiation and which UGT not mentioned) at the Nevada Test Site. Refs were made to the gamma-ray levels on double-base proplnts

4 Radiation Effects on Pyrotechnics

Neutron Irradiation of Pyrotechnics

Previously the definition of pyrotechnics included igniters, best sources, squibs, delays, etc. A tendency has developed to include squibs and related items as electroexplosive devices. Some of the data on the radiation effects has already been included in the effects on expls and refs to them will be made accordingly

Steady-State Reactor Irradiation

In the program that Frankford Arsenal conducted for the Air Force, Skopp et al (Refs 87 & 103) subjected proplnt actuated devices to a space environment. BlkPdr, M72 percussion primers and the T14 ignition element were exposed to an integrated dose of neutrons and gammas in the range of 10^{13} – 10^{15} n/cm² and 10^6 – 10^8 R. These items were exposed as component parts of the proplnt cartridge. Results showed marked physical, chemical and ballistic changes that occurred at the highest flux level

Avrami and Voreck reported (Ref 192) on the steady-state reactor irradiation of the igniter materials, BlkPdr and ALCLLO. As shown in Table 4, BlkPdr (74% K nitrate/10.4% S/15.6% C) received a maximum exposure of 5.20×10^{17} n/cm² fast neutrons (>0.18 MeV), 3.20×10^{18} n/cm² thermal neutrons, and 4.22×10^9 R gamma. Based on weight loss, BlkPdr was the most radiation-stable of all the materials tested for the NERVA program. The only stipulation was that its behavior became erratic above the mp of sulfur (120°)

ALCLLO (64% K chlorate/35% Al/1% Ca stearate) is an inorganic hot-particle igniter mix which was subjected to a total dose of 9.4×10^{16} n/cm² fast neutrons (>0.18 MeV), 5.8×10^{17} n/cm² thermal neutrons, and 5.0×10^8 R gamma. Its temp stability is very good and at the highest exposure its weight loss was 5.8%

Pulsed Reactor Irradiation

In the KIWI-TNT test of the NERVA program, BlkPdr was the only igniter tested in a pulse environment (Ref 192). In a ~1 msec pulse, the max dose the BlkPdr was exposed to was 3.0×10^{14} n/cm² fast neutrons, 1.1×10^{15} n/cm² thermal neutrons and 1.5×10^7 R gamma. On the various tests conducted no adverse effects were evident

Gamma Irradiation of Pyrotechnics

Only two reports of consequence became

evident during the search for the gamma irradiation of pyrotechnics and both of these were performed in the steady-state mode

Roots and Phillips (Ref 91) irradiated three types of electric ignition elements with Co^{60} gamma rays to a total dose of 2.5×10^6 R, without any adverse effects in their performance

Lipscomb and Parrish (Ref 191) conducted a program to determine the Co^{60} radiation effects on the heat of fusion of Na nitrate and the Co^{60} radiation effects on the heat of combustion of Mg. With a dose rate of 6.25×10^5 R/hr and a total dose of 5.3×10^8 R, the heat of combustion of Mg increased by 5% to 10%. When the material was heated to 210–250°, the heat of combustion increased by 10–20%. The heat of fusion of Na nitrate was not affected by a dose of 2.0×10^8 R. Also, no measurable change was noted in the DTA of the irradiated sample

Underground Testing (UGT) of Pyrotechnics

The earliest UGT ref to pyrotechnic ammo was reported by Willsey (Ref 22), in which 12 each M48 trip flares had been exposed at Test Able in Operations Crossroad. Also, M111A2 fuzes which contained Teteryl pellets (Ref 20) were exposed. However, as with the rest of the reports on that program, the levels were not given, and although located at three different distances from ground zero none of the items were affected

5 Computational Methods

Various computer codes exist which are used to simulate nuclear weapons effects on various targets. Variations of codes on radiation transport, shielding and cross sections also can be considered. A directory of currently used codes was compiled by Martin, Reitz and Root (Ref 23), which for the most part is a rather complete tabulation of computer programs applied to the numerical simulation of nuclear weapon expls phenomenology and effects

6 Bibliography

In the area of radiation effects on expls and propnts, a good number of bibliographical reports are available to assist an investigator (Refs 48, 64, 66, 116, 117, 118, 119, 138, 139, 158, 171, 173, 174, 214, 218 & 228). Many of them include abstracts of each ref which describes the effects of the nuclear environment on the material under study

Refs: 1) G.H. Henderson, "α-Particles as Detonators", Nature **109**, 749 (1922) 2) H.H. Poole, "α-Particles as Detonators", Nature **110**, 148–49 (1922) 3) Ibid, PrRoySoc **17**, 93 (1922) 4) P. Gunther, L. Lepin & K. Andreev, ZElectrochem **36**, 218 (1930) 5) R.H. Müller & G.C. Brous, "The Decomposition of Sodium Azide by Controlled Electron Bombardment", JACS **53**, 2428 (1931) 6) W.E. Garner & A.S. Gomm, "The Thermal Decomposition and Detonation of Lead Azide Crystals", JCS 2123–34 (1931) 7) W. Roginski, PhysZSow **1**, 656 (1932) 8) R.H. Müller & G.C. Brous, "The Decomposition of Sodium Azide by Controlled Electron Bombardment and by Ultraviolet Light", JChemPhys **1**, 482–91 (1933) 9) H. Kallmann & W. Schrankler, "On the Initiation of Explosion by Ion and Electron Impact", Naturwiss **21**, 379–82 (1933) & AEC TR 5706 (1963) 10) H. Muraour, "Effect of Electron Impact Upon Lead Azide and Silver Acetylide—Theoretical Observations Upon the Thermal Decomposition of Explosives", Chim&Ind **30**, 39–40 (1933) 11) Ibid, "Action of α-Rays of Polonium, X-rays and Ultra-violet rays on Nitrogen Iodide and other Explosives", SocChimBullFr **53**, 612–13 (1933) 12) W.E. Garner & C.H. Moon, "The Acceleration of the Decomposition of Solids by the Emission from Radium", JCS 1398–1400 (1933) 13) E. Feenberg, "The Detonation of Nitrogen Iodide by Nuclear Fission", PhysRev **55**, 980–81 (1939) 14) M. Haissinsky & R.J. Walen, "On the Detonation of Nitrogen Iodide under the Action of α-Rays of Polonium", CR **208**, 2069 (1939) 15) P. Fabre, C. Magnor & H. Muraour, "Detonation of Nitrogen Iodide by Fragments of the Uranium Nucleus Bombarded by Neutrons", CR **209**, 436–39 (1939) 16) W.E. Garner & J. Maggs, "The Action of Ultraviolet Radiation on Barium and Strontium Azides", PrRoySoc **A172**, 299–314 (1939) 17) N.F. Mott, "On the Decomposition of Metallic Azides", PrRoySoc **A172**, 325–35 (1939) 18) P. Gunther, L. Lepin & K. Andreev, "Decomposition of Solid Barium Azide Under the Action of X-rays", KhimReferatZh No 10–11, 120–21 (1940) & CA **37**, 1271 (1943) 19) R.C. Grass, "Tests of Ordnance Materials Exposed to Atomic Bomb Detonation", PATR **1690** (1948) 20) C.G. Scheibner, "Examination and Test of Bomb

Written by L. AVRAMI

- Fuzes Exposed at Crossroads", PATR 1701 (1948) 21) W.A. Noyes, Jr, "Joint National Military Establishment—AEC Panel on Radiological Warfare", Rept TID-204, p 59 (1948) 22) S.L. Willsey, "Examination of Pyrotechnic Ammunition Exposed at Crossroads Project", PATR 1702 (1948) 23) C. Goodman, "Effects of Nuclear Radiations on Explosives", MassInst-Technol, Lexington Proj Rept No LP-147 (1948) 24) R.C. Grass & O.E. Sheffield, "Tests of Ordnance Material Exposed to Atomic Bomb Detonation", PATR 1707 (1948) 25) A.B. Schilling, "Examination of Artillery Ammunition Exposed to Test in Operation Crossroad", PATR 1712 (1949) 26) K.S. Warren & O. Sisman, "Effects of Nuclear Radiation on Explosives", Oak Ridge Natl Lab Repts CF-50-4-103 (April 1950); CF-50-8-54 (Aug 1950); and CF-50-12-109 (Dec 1950) 27) J.G.N. Thomas & F.C. Tompkins, "On the Decomposition of Metallic Azides", JChemPhys 20 (4), 662-66 (1952) 28) F.P. Bowden & K. Singh, "Size Effects in the Initiation and Growth of Explosion", Nature 172, 378-80 (1953) 29) H. Muraour & A. Ertand, "The Action of a Neutron Flux on Primary Explosives", CR 237, 700-02 (1953) 30) H.G. Heal, "The Decomposition of Crystalline Sodium Azide by X-Ray", CanJChem 31, 1153-63 (1953) 31) G. Hennig, R. Lees & M.S. Matheson, JChemPhys 21, 664 (1953) 32) J. Berchtold & J. Eggert, "On the Ignitibility of Explosives via High-Intensity Irradiation", Naturwiss 40, 55-56 (1953) 33) J. Eggert, "Behavior of Endothermic Compounds on Illumination with High Intensities of Light. III", InternConfPhoto, London (1953) & CA 47, 3734 (1953) 34) J. Berchtold, "Behavior of Silver Nitride Towards the Effects of High Intensities of Light, and Their Use for Producing Images", InternConfPhot, London (1953) 35) F.P. Bowden & K. Singh, "Irradiation of Explosives with High Speed Particles and the Influence of Crystal Size on Explosion", ProcRoySoc A227, 22-37 (1954) 36) B. Meerkämper, "On the Behavior of Nitrogen Tri-iodide During Exposure to Irradiation of Various Intensities", ZElectrochim 58, 387-416 (1954) 37) K.S. Warren, D.E. Seeger, C.F. Dieter & O. Sisman, "Effects of Gamma Radiation on Explosives" (written by H. Rosenwasser), Oak Ridge Natl Lab Rpt ORNL-1720 (1955) 38) J.M. Grocock & F.C. Tompkins, "The Decomposition of Solid Azides by Electron Bombardment", PrRoySoc A223, 267-82 (1954) 39) J. Sawkill, "Nucleation in Silver Azide: An Investigation by Electron Microscopy and Diffraction", PrRoySoc A229, 135-42 (1955) 40) J.S. Courtney-Pratt & G.T. Rogers, "Initiation of Explosion by Light and by Flying Fragments", Nature 175, 632-33 (1955) 41) Anon, "Initiation of Explosives by Radiant Energy or Energetic Particles", ArmourResFound Proj No A058, Contract DA44-009-ENG-2438, Final Rpt 29 (March 1956) (AD-106621) 42) J.M. Grocock & T.R. Phillips, "The Effect of High Energy X-Rays on the Thermal Detonation of Service Lead Azide", ARDE Rpt (B) 7/56 (1956) 43) A. Owyang & H. Rosenwasser, "The Effects of Gamma Radiation on JPN Propellant", NPP-MR-122, Naval Powd Factory, Indian Head, Md (1956) 44) J.G. Dodd, Univ of Arkansas, Final Rpt, Contract No DA-44-009-ENG-2439, ERDL, Ft Belvoir (Oct 1956) 45) R. Smolucowski, "Irradiation Effects in Materials", Molecular Engineering, MIT (Aug 1956) 46) G.J. Dienes & G.H. Vineyard, "Radiation Effects in Solids", Interscience (1957) 47) H. Rosenwasser & C.L. Whitman, "Effects of Gamma Radiation on Nitrocellulose", NPP-MR-128, Naval Powd Factory, Indian Head, Md (1957) 48) J.R. Holden, "Literature Survey on the Effects of Neutron and Electromagnetic Irradiation on Explosives", NAVORD 4448 (1957) (AD-127340) 49) J.E. Abel et al, "The Effect of Nuclear Radiation on Explosives and Related Materials", PATR 2398 (1957) 50) R.C. Ling, "Penetration of Explosives by Heavy Nuclear Particles", PATR 2393 (1957) 51) J.V.R. Kaufman, "The Effects of Nuclear Radiation on Explosives and Related Materials", Vol IV, 132-43, US Army Science Conf, West Point (1957) (AD-149431) 52) H.G. Heal, "Further Observations on the Decomposition of Solid Sodium Azide by X-Rays", TrFaradSoc 53, 210-17 (1957) 53) J.V.R. Kaufman, "The Effect of Nuclear Radiation on the M26 Primer and M19A2 Detonator", Proceedings of 1957 Electric Initiator Symp, Chapt XXXI, Franklin Inst (Sept 1957) 54) A.C. McLaren, PhD Thesis, Cambridge, 1957 (unpublished), data in F.P. Bowden & A.D. Yoffe, "Fast Re-

- actions in Solids", Butterworth, London (1958), 119 (Ref 56) 55) A. Owyang & R.W. Williams, "The Effects of Gamma Radiation on OGK Propellant", **NPP-MR-138**, Naval Powder Factory, Indian Head (1957) 56) F.P. Bowden & A.D. Yoffe, "Fast Reactions in Solids", Academic Press, NY (1958) 57) F.P. Bowden, "The Initiation of Explosion by Neutrons, α -Particles and Fission Products", **ProcRoySoc A246**, 216-19 (1958) 58) J.V.R. Kaufman, "The Effect of Nuclear Radiation on Explosives", **ProcRoySoc A246**, 219-25 (1958) 59) J.M. Groocock, "The Effect of High Energy X-rays and Pile Irradiation in the Thermal Decomposition and Thermal Explosion of α -Lead Azide", **ProcRoySoc A246**, 225-32 (1958) 60) J.K. Raney, "Neutron and Gamma Irradiation of Lead and Potassium Azides", **BullAmPhysSoc [2]**, **3**, 117 (1958) 61) T.B. Flanagan, "Effects of Nuclear Irradiation upon the Decomposition of Lead Styphnate Monohydrate", **Nature 181**, 42-43 (1958) 62) H.A. Winnerling, "Effect of High-Intensity Short Duration Nuclear Radiation on Cast Double-Base Solid Propellant", **ABL ResProg Reports**, 30 June-3 Nov (1957) & 1 Dec 1957-31 Jan (1958) 63) J.E. Abel et al, "Effects of Reactor and Gamma Ray Irradiation on the Sensitivity of Lead Azide" **PATR 2500** (1958) 64) F.E. Frost, "Effects of Nuclear Radiation on Explosives and Solid Propellants-A Bibliography", **UCRL 5322**, Univ of Calif Radiation Lab, Livermore (1958) 65) L.T. Carleton & J.P. Kispersky, "Effect of High Energy Radiation on Solid Composite Rocket Propellants", **WADC-TR-57-596**, Contract AF 33 (616)-3726, Aerojet General Corp, Azusa (1958) (AD-303729L) 66) Anon, "Radiation Effects-Methods and Data", **NARF-58-43T**, **FZK-9-134**, Contract AF 33 (600)-32054, General Dynamics-Convair, San Diego (1958) 67) Anon, "Gamma Irradiated Polysulfide Solid Composite Propellants", Rept **E58-58**, Contract AF 33 (606)-3971, Thiokol Chemical Co, Elkton (1958) (AD-301364) 68) J. Fugger, "Gamma Irradiated Polysulfide Solid Composite Propellants", Vol III, 14th **JANAF Mtg** (1958), 165-200 69) R.W. Dreyfus & P.W. Levy, "Preparation and Properties of Crystals of Potassium and Sodium Azide", **ProcRoySoc A246**, 233-40 (1958) 70) G. Todd & E. Parry, "Surface Hardness of Explosive Materials by Micro Hardness", **Nature 181**, 260-61 (1958) 71) V.V. Sviridov, **DoklAkadN, SSR 2**, 291 (1958) 72) J. Eggert, "The Initiation of Explosion by Light", **ProcRoySoc A246**, 240-47 (1958) 73) J.H.L. McAuslan, "Ignition of Explosives by Light", **ProcRoySoc A246**, 248-50 (1958) 74) J. Eggert, "The Ignition of Explosives by Radiation", **JPhysChem 63**, 11-15 (1959) 75) J.E. Mapes et al, "Effect of Gamma-Ray and Reactor Irradiations on Nitrocellulose-Bonded HMX", **PATR 2607** (1959) 76) W.J. Marciniak & T.D. Phillips, "Effect of Gamma Radiation from Cobalt 60 on the Mechanical Properties of AHH and ARP Double-Base Solid Propellants", **NPP-TMR-159**, Naval Powder Factory, Indian Head (1959) 77) Y.K. Roots & T.D. Phillips, "Oxygen Taliani Test of Gamma-Irradiated Propellants ARP, AHH, and CDT", **NPP-TMR-172**, Naval Proplnt Plant, Indian Head (1959) 78) E.S. Freeman et al, "The Effects of X-Ray and Gamma Ray Irradiation on the Thermal Decomposition of Ammonium Perchlorate in the Solid State", **JPhysChem 64**, 1727 (1960); also **PATR 2673** (1960) 79) G. Todd & E. Parry, "Radiation Induced Changes in α -Lead Azide", **Nature 186**, 543-44 (1960) 80) J.M. Groocock, "The Decomposition of Alpha-Lead Azide", 2nd **ONR Symp Deton** (1960) (AD-52144) 81) L.T. Carleton et al, "Effect of High- and Low-Intensity Radiation on Solid Composite Rocket Propellants", **Final Rpt 1794**, Contract AF 33(616)-5792, Aerojet-General Corp, Azusa (1960) (AD-316898) 82) S.K. Deb et al, "Ignition and Sensitized Reactions in the Explosive Inorganic Azide", 8th **Symp Combstn** (1962), 829-36 83) J.E. Mapes et al, "Effects of Gamma-Ray Irradiations on Five Plastic-Coated High Explosive Compositions", **TID-15426**, Brookhaven Natl Lab, Upton (1960) 84) M.M. Fein & E. O'Brien, "Development of Solid Propellants for Application in Extended Temperature and Space Environmental Conditions", **RMD-1147-F**, Contract AF 33(616)-6424, Thiokol Chem Corp, Denville (1960) (AD-318523) 85) Y.K. Roots & T.D. Phillips, "Effects of Gamma Radiation from Cobalt 60 on the Mechanical Properties of Solid Propellants ALL and CDT", **NPP-TMR-179**, Naval Proplnt Plant, Indian Head (1960) 86) K.J. Haley, "Radiation Effects on the

- Physical and Ballistic Properties of Minuteman Solid Propellant", Rept **AS60-Y002-02622**, Thiokol Chem Corp, Elkton (1960); also in Trans of 5th Symp on Ballistic Missile & Space Technol, Vol II (1960) (AD-323311) 87) G.S. Skopp, "Basic Investigation of the Operation of Propellant Actuated Devices in Space Environment, Phase II, A Theoretical Study", Rept **FA-R-1546**, Frankford Ars, Phila (1960) (AD-255205) 88) F.P. Bowden & H.M. Montagu-Pollock, "Slow Decomposition of Explosive Crystals and their Damage by Fission Fragments", Nature **191**, 556-59 (1961) 89) F.P. Bowden & L.T. Chadderton, "Molecular Disarray in a Crystal Lattice Produced by a Fission Fragment", Nature **192**, 31-34 (1961) 90) W.L. Fink, "Investigation of Radiation Effects Problems in Nuclear Heat Exchanger Rockets", Rept **GD-FZK-137**, Contract NAS 8-1609, General Dynamics, Fort Worth (1961) 91) Y.K. Roots & T.D. Phillips, "Effect of Gamma Radiation from a Cobalt-60 Source Upon the Sensitivity of Electric Ignition Elements MK2, MK4, and MK6", Rept **NPP-TMR-191**, Naval Proplnt Plant, Indian Head (1961) 92) R.E. Gardner, "Effects of Ionizing Radiation on Solid Rocket Motor Components", NASA Rept **TR-32-234** (1961) (AD-273824) 93) D.S. Billington & J.H. Crawford, Jr, "Radiation Damage in Solids", Princeton Univ Press (1961) 94) T.B. Flanagan, TransFaradSoc **57**, 797 (1961) 95) F.P. Bowden & A.D. Yoffe, "Explosion in Liquids and Solids", Endeavor, 125-36 (Oct 1962) 96) H.M. Montagu-Pollock, "Surface Decomposition of an Explosive Crystal", ProcRoySoc **A269**, 219-32 (1962) 97) F.P. Bowden & L.T. Chadderton, "Fission Fragment Damage to Crystal Lattices: Dislocation Formation", ProcRoySoc **A269**, 143-64 (1962) 98) M.J. Urizar et al, "The Effects of Nuclear Radiation on Organic Explosives", Explosivst **3**, 55 (1962); also Rept **LADC-4795, TID-12491**, Los Alamos Scientific Lab, Los Alamos (1960) 99) R.E. Gardner, "Effects of Ionizing Radiation on Solid Rocket Motor Components", JAmRocketSoc **32**, 1050 (1962) 100) E. Piantanida & M. Piazzi, "Behavior of Explosives Under the Action of Gamma Rays, II", PATM **1040** (1962) [Translation from La Chimica e l'Industria **43**, 1389 (1961)] 101) R.A. Biddle, "The Effects of Space Aging on Solid Composite Propellants", Bull of Combined Panel Mtg, 18th JANAF Panel on Analytical Chemistry of Solid Propellants, Thiokol Chem Corp, Elkton (1962), 23-38; also available as NASA **X63-10339** 102) B.V. Yerofeyev & V.V. Sviridov, "The Influence of Irradiation with X-Rays on the Kinetics of the Thermal Decomposition of Barium Azide", Institut Khimii AN BSSR, Nauchnykh Rabot **5**, 113-29 (1956); translated in PATN **FRL-TN-75** (1962) 103) G.S. Skopp et al, "Basic Investigation of the Operation of Propellant Activated Devices in Space Environment", **FA-R-1595**, Frankford Ars, Phila (1962) (AD-409083) 104) Anon, "Propellants for Electrical Propulsion Engines of the Contact or Bombardment Ion Type", **ASD TR-61-150**, Pt II, Contract AF 33(616)-7063, North Amer Aviation, Rocketdyne (1962) (AD-293913) 105) T.B. Flanagan, JPhysChem **66**, 416 (1962) 106) F.P. Bowden, "The Initiation and Growth of Explosion in the Condensed Phase", Proc 9th Intern Symp Combstn, Academic Press, NY (1963), 499-516 107) T.B. Flanagan, "The Effects of Reactor Irradiation Upon the Subsequent Thermal Decomposition of Lead Styphnate", JPhysChem **66**, 416 (1962) 108) R.O. Bolt & J.C. Carroll, Eds, "Radiation Effects in Organic Materials", Academic Press, NY (1963) 109) J. Cerny et al, "Range-Energy Relations for Protons and Alpha Particles in Various Explosives", Nature **198**, 371-72 (1963) 110) J. Jach, "Thermal Decomposition of Irradiated α -Lead Azide", TransFaradSoc **59**, 947 (1963) 111) Ibid, "Thermal Decomposition of Irradiated α -Lead Azide", **BNL-6032**, Brookhaven Natl Lab, Upton (1963) 112) J.G. Horton, "Exploration of Solid Propellant Characteristics Under Simulated Space Conditions", Proc 1963 Mtg Inst of Environmental Sciences (1963), 177-84 113) G. Odian et al, "Radiation-Induced Solid Propellant Decomposition", **RAI-314**, Contract AF 49 (638)-1125, Radiation Application, Inc, Long Island City (1963) 114) R. Blanchard, "Thermal Initiation of Explosives by Luminous Flashes", CR **256**, 2550-53 (1963) 115) E. Piantanida & M. Piazzi, "Behavior of Explosives Under Gamma Irradiation, (I) and (III)", PATM **1078** (1963) (AD-401473) [translation from La Chimica e L'Industria **42**, 1238 (1960) & **44**, 247 (1962)] 116) Anon, "Radiation Effects

- on Propellants-References", CPIA Publication No 15 (1963) 117) Anon, "Compilation of Nuclear, Pulsed, and Space Radiation Effects Projects", REIC Memorandum 11-C, Battelle Memorial Inst, Columbus (1963) (AD-338950) 118) H.M. Abbott, "Radiation Effects on Propellants, Explosives and Related Materials: An Annotated Bibliography (U)", Rpt No 6-90-63-54, Lockheed Missiles & Space Co, Sunnyvale (1963) (C) (AD-340240) 119) Anon, "Radiation Effects on Propellants-Additional References", CPIA Publication No 15A (1963) 120) R.M. Brownell et al, "Examination of Propellants for Use in Space Environments", CPIA Publication No 18, Bull of the Interagency Solid Propulsion Mtg, Vol II (1963), 467-95 121) J. Berberet, "The Effect of Nuclear Radiations of Explosive Solids", Det 4 Aeronautical Systems Div Tech Documentary Rept No ASD-TDR-63-893, AF Systems Command (1 Apr-1 July 1963) 122) S.S. Miller, "Survey of Radiation Effects on Propellants", CPIA Publication No 31 (1963) (AD-364628) 123) J.A. Berberet, "Radiation Effects on Explosives", ASD-TDR-63-33, General Electric Co-TEMPO, Santa Barbara (1963) 124) J.M. Allen et al, "Evaluation of Solid Propellants and Solid-Propellant Systems for Space Applications", BMI-1863-SR (NAS-8-1683), Battelle Memorial Inst, Columbus (1963) 125) A. San Miguel & E.N. Duran, "The Experimental and Theoretical Significances Associated with Irradiated Propellants", JPL-TR-32-518, Jet Propulsion Lab, Calif Inst of Technol, Pasadena (1963) 126) R. Scott et al, "Effect of Simulated Space Environment on Properties of Polycarbutene Solid Propellants", Final Rept LPC-RWO-3103-F-63, Lockheed Propulsion Co, Redlands (1963) 127) E.D. Laughran, unpublished work (1963-1969) 128) J. Cerny & J.V.R. Kaufman, "Consideration of Spherical Hot Spots Arising from P ion Capture in Explosives Using Thermal Initiation Theory", JChemPhys 40, 1736-44 (1964) 129) J.F. Mallay, H.J. Prask & J. Cerny, "Inadequacy of Thermal Initiation Theory in Interpreting the Results of Fission Fragment Irradiation of Explosives at Elevated Temperatures", Nature 203, 473-76 (1964) 130) A. Mackenzie & E.W. Dalrymple, "Burst Test Results Simplify Design of Irradiation Capsules for Explosive Materials", Nuclear 22 (2), 85-87 (1964) 131) E.G. Prout & D.J. Moore, "Thermal Decomposition of Barium Azide", Nature 203, 860-61 (1964) 132) J. Roth, "Initiation of Lead Azide by High Intensity Light", JChemPhys 41, 1929-36 (1964) 133) G. Odian et al, "Radiation-Induced Solid Propellant Decomposition", RA1-331, Radiation Applications, Inc, Long Island City (1964) (AD-604475) 134) T. Acker et al, "Effect of Radiation on Ammonium Perchlorate Propellants", AFOSR-65-1435, Radiation Applications, Inc, Long Island City (1964) (AD-622649) 135) J.E. Mapes et al, "Effects of Gamma-Ray and Reactor Irradiations on Impact Sensitivity of Small Arms Percussion Primers", PATR 3044 (1964) 136) J.E. Abel et al, "Effects of Gamma-Ray Irradiation on M1 Propellant", PATR 3114 (1964) (AD-349993) 137) A.K. Cornelius et al, "Space Environmental Studies-Volume I, Radiation of Propellants and Propellant/Seals", Rept AGC-2943-Vol I, Aerojet-General Corp, Sacramento (1964) (AD-356186) 138) Anon, "Radiation Effects Data Book", AGC-2277, Aerojet-General Corp, Sacramento (1964) 139) Anon, "Compilation of Nuclear, Pulsed, and Space Radiation Effects Projects", REIC Memorandum 14-C, Radiation Effects Information Center, Battelle Memorial Inst, Columbus (1964) (AD-354391) 140) J.A. Berberet, "Radiation Effects on Explosives, Rept ASD-TDR-64-52, General Electric Co-TEMPO, Santa Barbara (1964) 141) Ibid, "The Effects of Nuclear Radiation on Explosive Solids", Rept ATL-TDR-64-53, Ibid (1964) 142) Anon, "Engineering Investigation and Tests Which Further Substantiate System Feasibility and Provide Data to the Development of a Nuclear Low Altitude Supersonic Vehicle, Part II-Technical Information Vol 9", Tech Rept ASD-TR-64-91, NS-S-415, Ling-Temco-Vought, Inc, Dallas (1964) 143) J.F. Kircher & R.E. Bowman, Eds, "Effects of Radiation on Materials and Components", Reinhold, NY (1964) 144) V.V. Boldyrev & A.I. Skorik, "Thermal Decomposition of Silver and Barium Azides at Instant of X-Ray Irradiation", AN SSR, Doklady 156 (5), 1143-46 (1964) 145) P.W. Levy, "Use of Color Centers for Detection and Measurement of Defects", ASTM Special Tech Publ No 359 (1964) 146) O.I. Leipunskii et al, "The Propagation of Gamma Quanta in Matter"

- (translated by P. Basu, Pergamon Press, Oxford, Engl (1965) 147) L.T. Chadderton, "Radiation Damage in Crystals", Metheun & Co, London (1965) 148) H. Rosenwasser et al, "Radiation Induced Coloring of Sodium Azide", *JChemPhys* **24**, 184-90 (1965) 149) E.G. Prout & D.J. Moore, "Thermal Decomposition of Strontium Azide", *Nature* **205**, 1209-11 (1965)
- 150) Anon, "Radiation-Induced Solid Propellant Decomposition", **RAI-347**, Radiation Applications, Inc, Long Island City (1965) (AD-612536)
- 151) J.E. Mapes et al, "Physical Effects of Gamma Rays on Plastic-Bonded HMX and DATB Compositions-Group I", **PATR 3106** (1965) (AD-357351) 152) Ibid, **PATR 3107** (1965) (AD-357350) 153) J.E. Abel & P.W. Levy, "Effects of Ultraviolet Irradiation on the Sensitivity of Colloidal Lead Azide", **PATR 3174** (1965) 154) Anon, "Phase One of the Countermeasures Radiation Effects Program, Final Test Report", Rept **RN-S-0210**, Aerojet-General Corp, Sacramento (1965)
- 155) Anon, "Phase I-B of the Countermeasures Radiation Effects Program, Final Report", Rept **RN-S-0217**, Aerojet-General Corp, Sacramento (1965) 156) A. Mackenzie et al, "Design of Pressure Vessels for Confining Explosive", **PATM 1643** (1965) 157) M. Piazzi, "The Course of the Thermal Decomposition of Explosives Exposed to Gamma Radiation", *La Chimica e L'Industria* **47**, No 3, 276 (1965) [translated as Redstone Ars Rept **RSIC-466** (1965) (AD-469196L)] 158) B.A. Gilmour, "Radiation Effects on Propellants and Explosives: An Annotated Bibliography", **REIC Memorandum 28**, Battelle Memorial Inst, Columbus (1965) (AD-474256) 159) Anon, "Phase I-D (KIWI-TNT) of the Countermeasures Radiation Effects Program, Final Test Report", Rept **RN-S-0268**, Aerojet-General Corp, Sacramento (1965)
- 160) K. Vollrath, "Sur L'Amorçage des Explosifs Primaires à l'Aide de Faesceaux Laser" (On the Initiation of Primary Explosives with the Aid of a Laser Beam), Fr-Ger Inst of Saint-Louis Note **ISL 4/65**, Saint Louis, Fr (1965) 161) V.N. Velyunov & O.B. Sedonskii, "The Problem of Igniting Explosive Systems with Radiation Energy", *FizGyorVzr* **4**, 39-43 (1965)
- 162) J. Flanagan & J.C. Gray, "A Study of Composite Solid Propellants Containing Irradiated Ammonium Perchlorate", *JSpacecraft&Rockets* **3**, 135 (1966) 163) P.J. Herley & P.W. Levy, "Thermal Decomposition of Irradiated Orthorhombic Ammonium Perchlorate", *Nature*, 1287 (1966) 164) T.C. Castorina et al, "Radiation-Enhanced Surface Activity of Gamma HMX", **PATR 3282** (1966) 165) Anon, "Phase I-C of the Countermeasures Radiation Effects Program, Final Test Report", Rept **RN-S-280**, Aerojet-General Corp, Sacramento (1966) 166) J. Jach, "The Thermal Decomposition of Irradiated Materials", Rept No **2**, Contract NONR-4673(00), Task No NR 056-467, State Univ of NY, Stony Brook (1966) (AD-631997) 167) Ibid, "The Thermal Decomposition of Irradiated Materials, Studies in Radiation Effects", Vol **2**, G.J. Dienes, Ed, Gordon & Breach, NY (1966) (AD-631997) 168) A.A. Brish et al, "Initiation of Detonation in Condensed Explosives by Laser Emission", *FizGyorVzr* **2**, No 3, 132-33 (1966) 169) E.V. Konev & S.S. Khlevnoi, "Combustion of an Explosive in the Presence of Illumination", *Ibid* **4**, No 1, 33-41 (1966) 170) E.G. Kessler, "The Initiation of Explosives by Means of Laser Radiation", *EngSciencesLabInternal Rept ESL-IR-248*, PicArnsn, Dover (1966) 171) H.M. Abbott, "Radiation Effects on Solid Propellants: An Annotated Bibliography", Rept **LMSC-LS-66-17**, Lockheed Missiles & Space Co, Palo Alto (1966) (AD-487137) 172) J.A. Berberet, "Basic Effects Produced by Nuclear Radiations in Explosive Solids", Rept **TMP-49006, AFATL-TR-66-90**, General Electric Co-TEMPO, Santa Barbara (1966) (AD-375911) 173) H.M. Abbott, "Radiation Effects on Explosive and Shock Wave Studies: An Annotated Bibliography", Rept **LMSC-LS-66-24**, Lockheed Missiles & Space Co, Palo Alto (1966) (AD-801929) 174) M.E. Franklin, "Vulnerability of Nuclear Weapons: Bibliography and Indices", **NWEF 1003**, Naval Weapons Evaluation Facility, Albuquerque (1966) 175) V.C. Garrison, "Interim Report Weapon System 133B, Testing for Irradiation Effects", Rept **TAI-51-2-7, TWR-2303**, Thiokol Chemical Corp, Brigham City (1967) 176) Anon, "Phase I-A of the Countermeasures Radiation Effects Program, Final Test Report", Rept **RN-S-0368**, Aerojet-General Corp, Sacramento (1967) 177) J.P. Coughlin & R.R. Tsukimura, "Lattice Deformation Study", Final Report **1032-81F, AFRPL-**

- TR-67-297, Aerojet-General Corp, Sacramento (1967) 178) P.J. Herley & P.W. Levy, "Effects of X- and Γ -Ray Radiation on the Thermal Decomposition of Solid Orthorhombic Ammonium Perchlorate. I. Experimental and Results", *JChemPhys* **49**, 1493 (1968) 179) Ibid, "Ibid. II. Kinetics and Discussion", *JChemPhys* **49**, 1500 (1968) 180) T. Castorina et al, "Radiation Enhanced Surface Activity of an Ordnance Explosive, α -HMX", *IntJApplRad&Isotope* **19**, 495 (1968) 181) Y.A. Zakharov et al, "X-Ray Induced Decomposition of Single Crystals of PbN_6 ", *Kinetika i Kataliz* **9** (3), 679-81 (1968) 182) S.M. Ryabykh et al, "Radiolysis of Single Crystals of Lead Azide", *KhimVysokikhEnergii* **2** (4), 344-48 (1968) 183) A.N. Dremin & S.D. Savrev, "Detonation Initiation in a Liquid Explosive by a Light Pulse", *AN SSSR Doklady* **179** (3), 624-26 (1968) 184) V.F. Mikheev et al, "Ignition of a Ballistite Propellant by Light Radiation", *FizGorVzr* **4** (1), 3-9 (1968) 185) S.S. Khlevnoi & A.P. Karmykova, "Ignition of Nitroglycerin Powder by Light Radiation in a Cold Stream of Gas", *FizGorVzr* **4** (1), 122-24 (1968) 186) L. Avrami et al, "A Large Containment Capsule for Nuclear Reactor Irradiation of Explosive Materials", *PATR* **3673** (1968) 187) L. d'Ast, "Initiation des Explosifs d'Amoragage par Electron et par Photons", *Atelier de Construction de Tarbes, D.T.A.T., Fr* [Clearinghouse, US Dept of Commerce, **N69-13509** (1968)] 188) Yu.A. Zakharov et al, "Effect of Prior Irradiation in the Thermal Decomposition of Ammonium Perchlorate", *KhimVysoEnergii* **3**, 443 (1969) 189) A.A. Brish et al, "The Mechanism of Initiation of Condensed Explosives by Laser Initiation", *FizGorVzr* **4**, 475-80 (1969) 190) W.R. Woodruff, "Radiation Damage Evaluation Wing VI Minuteman Rocket Motor-Final Report", *Rept MTO 852-35*, Hercules, Inc, Magna (1969) (AD-849481) 191) C.A. Lipscomb & C.F. Parrish, "Physical Factors Influencing the Chemical Reactivity of Solid Materials-A Preliminary Investigation", *NAD-CR-RDTR-137*, Naval Ammo Depot, Crane (1969) 192) L. Avrami & W.E. Voreck, "A Determination of Reactor-Radiation-Resistant Explosives, Propellants and Related Materials", *PATR* **3782** (1969) (AD-506895L) 193) E.R. Johnson, "The Radiation Induced Decomposition of Inorganic Molecular Ions", *Gorden and Breach, NY* (1970) 194) W.E. Voreck, "Capsule for Irradiation of Explosives", *Nuclear Applications* **6**, 582-87 (1969) 195) M.J. Barbarisi & E.G. Kessler, "Initiation of Secondary Explosives by Means of Laser Radiation", *PATR* **3861** (1969) 196) S.M. Ryabykh et al, "Decomposition of AgN_3 Single Crystals Under X-Ray Radiation", *IzvVysKhim-Tekh* **13** (11), 1558-60 (1970) 197) Y.A. Zakharov & S.M. Ryabykh, "Change in the Radiation Stability of Lead Azide Using Additives", *IzvTomskPolitekhInst* **176**, 107-10 (1970) 198) Y.A. Zakharov et al, "Change in the Radiochemical Stability of PbN_6 Induced by Heterophase Additives", *IzvTomskPolitekhInstKir* **251**, 8-14 (1970) 199) R.H. Rowland & E.J. Martin, "A Guide to Nuclear Weapons Effects Literature", *DASIAC-SR-102*, General Electric Co-TEMPO, Santa Barbara (1970) 200) A.N. Oblivantsev et al, "Gamma Ray and Proton Radiolysis of Solid Inorganic Ionic Salts with Complex Anions", *IzvTomskPolitekhInst* **176**, 122-27 (1970) 201) P.V. Phung, "Initiation of Explosives by High-Energy Electrons", *JChemPhys* **53**, 2906-13 (1970) 202) A.B. Wenzal & W.E. Baker, "The Use of Light-Initiated Explosives for the Impulse Loading of Structures", *Proc Inst of Environmental Sciences, 16th Annual Tech Mtg* (1970), 142-50 203) C. Ribando et al, "The Effects of Reactor Irradiation on the Chemical Characteristics of Solid Explosives", *PATR* **3893** (1970) (AD-701786) 204) V.J. Menichelli & L.C. Yang, "Sensitivity of Explosives to Laser Energy", *TR* **32-174**, Jet Propulsion Lab, Pasadena (1970) 205) L. Avrami et al, "Effects of Gamma Radiation on Selected Fluoroexplosives", *PATR* **3942** (1970) (AD-509621) 206) V.J. Menichelli & L.C. Yang, "Direct Laser Initiation of Insensitive Explosives", *Proc 7th Symp Expls & Pyrots, III-2*, Franklin Inst Res Labs, Phila (1971), 1-8 207) L.C. Yang & V.J. Menichelli, "Detonation of High Explosives by a Q-Switch Ruby Laser", *ApplPhys-Ltrs* **19** (11), 473-75 (1971) 208) P.W. Levy & P.J. Herley, "Effects of Radiation on the Thermal Decomposition Induction Period in Ammonium Perchlorate and other Pseudo-stable Materials", *JChemPhys* **75**, 191 (1971) 209) V.V. Boldyrev, "Radiolysis of Crystalline

- Azide, Bromates and Nitrates", *International-JRadPhys&Chem* **3** (2), 155 (1971)
- 210) P.W. Levy et al, "Kinetics of Defect and Radiolytic Formation in Single Crystal Sodium Bromate Determined from Color Center Measurements", *JPhysChem* **76**, 3751 (1972)
- 211) P.J. Herley & P.W. Levy, "Quantitative Studies on Radiation-Induced Dislocations and the Decomposition Kinetics of Ammonium Perchlorate", *Proc 7th InternSymp on Reactivity of Solids*, J.S. Anderson et al, Eds, Chapman & Hall, London (1972), 387
- 212) A.B. Zimmerschied, "Debris Removal Installation Radiation Testing", Code Ident No **81205**, No **D2-19844-1**, The Boeing Co, Seattle (1972)
- 213) V.J. Menichelli & L.C. Yang, "Initiation of Insensitive Explosives by Laser Energy", Tech Rept **32-1557**, NASA-CR-126741, Jet Propulsion Lab, Pasadena (1972)
- 214) B.M. Dobratz, "Bibliography on Radiation Effects on Primary and Secondary Explosives and on Propellants", **UCID-16087**, LLL, Livermore (1972)
- 215) A.H. Kazi & J.L. Watson, "Nuclear Engineering Problems of a Burning Rocket Motor Neutron Irradiation", Rept No **BRL-MR-2217**, Ballistic Res Lab, Aberdeen Prov Grnd (1972) (AD-905550L)
- 216) H.N. Lewis et al, "Neutron Radiation Effects on Solid Propellant Burning", Rept No **BRL-MR-2274**, *Ibid* (1973) (AD-909326L)
- 217) F.A. Farber, "The Effect of a High Energy Electron Beam on Explosives", Master's Thesis (F224), Naval Postgraduate School, Monterey (1972) (AD-771527)
- 218) V. Plummer, "Bibliography on Gamma Radiation", Rept **MAC-LB-726-1**, McDonnell Aircraft Co, St Louis (1973) (AD-921738)
- 219) S.R. Kurowski, E.F. Hartman & J.E. Glover, unpublished work. Tests conducted Aug 1973. Private communication to L. Avrami, also reported in Ref 257
- 220) H.N. Lewis et al, "Neutron Radiation Effects on Sprint Type Solid Propellant Burning", Vol III, paper A2, Proceedings of 3rd Annual Meeting of Nuclear Survivability Working Group for Propulsion and Ordnance Systems, **DNA 2987P-3** (1973) (SRD), 255-70, (AD-528720), paper unclassified
- 221) R.J. Wood & A.B. Zimmerschied, "Debris System Ordnance Survivability", Vol I, paper 3.1, *Ibid*, **DNA 2987P-1** (1973) (SRD), 397-432, paper unclassified
- 222) L. Avrami et al, "Pulsed Neutron Effects on Spartan Ordnance and Explosives (U)", **PATR 4569** (SRD) (1973), (AD-530405)
- 223) L. Avrami et al, "Radiation-Induced Changes in Explosive Materials", **PATR 4602** (1973) (AD-775371)
- 224) P.J. Herley et al, "Effect of Fast Neutron, Gamma-ray and Combined Radiations on the Thermal Decomposition of Ammonium Perchlorate Single Crystals", *JChemPhys* **60**, 2340 (1974)
- 225) L.C. Yang et al, "Laser Initiation of Explosive Devices", *Natl Defense* (Jan-Feb 1974), 344-47
- 226) D.A. Wiegand, "Photoproduction of Disorder in $Pb(N_3)_2$ and TiN_3 ", *PhysRev B* **10**, 1241-47 (1974)
- 227) P.W. Levy, "Physical Principles of Thermoluminescence and Recent Developments in its Measurement", Rept **BNL-20210**, Brookhaven Natl Lab, Upton (1974)
- 228) H. Paitchel et al, "Sourcebook of Radiation Effects on Propellants, Explosives, and Pyrotechnics, Volume I", Rept **DNA 2881F-1**, Defense Nuclear Agency (1974) (AD-916941L)
- 229) A.W. Barrows et al, "Neutron Irradiation of Burning Propellant in the APRF Glory Hole", Rept **BRL-MR-2365**, Ballistic Res Labs, Aberdeen Proving Grnd (1974) (AD-919653L)
- 230) W.D. Hutchinson, "Neutron Effects on Arcadene 242A Propellant", Rept **MDC G5460**, McDonnell Douglas Astronautics Co-West, Huntington Beach (1974)
- 231) E. Martin et al, "Nuclear Weapons Effects Computer Code Directory", **DASIAC-SR-142**, DASA Information & Analysis Center, General Electric Co-TEMPO, Santa Barbara, Defense Nuclear Agency Rept **DNA 3540F** (1974)
- 232) L. Avrami et al, "Initiation of Lead Azide by Pulsed Electron Beam", *Proc of International Conf on Res in Primary Expls* (1975)
- 233) J.E. Glover, E.F. Hartman & co-workers at Sandia Labs, Albuquerque (private communications); noted in Ref 257
- 234) J.R. Ward et al, "Effect of Neutron Irradiation on Military Grade Ammonium Perchlorate", **BRL-MR-2448**, Ballistic Res Labs, Aberdeen Proving Grnd, Md (1975) (AD-B003210L)
- 235) C.W. Nelson & A.W. Barrows, "Short Lived Burn Rate Changes in Neutron Radiation Experiments", **BRL-MR-2475**, *Ibid* (1975) (AD-B003940L)
- 236) P.L. Morgan et al, "Bibliography on the Vulnerability of Nuclear Weapons, Nuclear Radiation Environment", Rept No **8300**, Naval Weapons Evaluation Facility, Albuquerque, Vol 7 (1975)
- 237) A.W. Barrows, Jr et al, "Short Lived Burn Rate Changes—Measurements

- and Effects", Vol 1, paper 2.4, Defense Nuclear Agency Rept **DNA-3557P-1**, pp 347-65, Proc 4th Symp, Nuclear Survivability of Propulsion and Ordnance Systems (1975) (SRD) (AD-C003279) (paper unclassified) 238) J.R. Ward et al, "Effect of Neutron Irradiation on Ammonium Perchlorate", Ibid, paper 2.5, pp 367-79 (1975) 239) A.H. Kazi et al, "Fast Neutron Pulse Irradiation Techniques for Ordnance Items and Burning Miniature Rocket Motors", Ibid, paper 3.1, pp 401-50 (1975) 240) R. Finn et al, "Recent Radiation Effect Studies on Ammonium Perchlorate. Part I: Thermal Decomposition Kinetics of Ammonium Perchlorate Single Crystals Following Irradiation with Gamma Rays and Fast Neutrons at Different Dose Rates", Ibid, paper 2.2a, pp 273-300 (1975) 241) P.J. Herley et al, "Recent Radiation Effect Studies on Ammonium Perchlorate. Part II: The Effect of Fast Neutron, Gamma Ray and Combined Radiation on the Thermal Decompositions of Ammonium Perchlorate Powder-Aluminum Particle Mixtures", Ibid, paper 2.2b, pp 301-15 (1975) 242) W.D. Hutchinson, "Neutron Effects on Solid Propellants", Ibid, paper 2.6, pp 281-99 (1975) 243) R.A. Benham & F.H. Mathews, "X-Ray Simulation with Light-Initiated Explosive", The Shock & Vibration Bulletin, No 45, Part 4 (1975) 244) G.E. Fuller & P.W. Levy, "Thermal Decomposition of Ammonium Perchlorate During Gamma-Ray Irradiation", Defense Nuclear Agency Rept **DNA-4032P-3**, Proc 5th Symp, Nuclear Survivability of Propulsion and Ordnance Systems, Vol III, paper 6.2 (1975) (paper unclassified) 245) J.R. Ward & J.J. Rocchio, "Effect of Neutron Radiation on the Rate of Ammonium Perchlorate Decomposition Reactions Involved in Combustion", Ibid, paper 6.4, pp 271-80 (1975) 246) Ibid, "Effect of Neutron Radiation on the Vaporization of Ammonium Perchlorate-A Combustion Related Process", **BRL-MR-2550**, Ballistic Res Labs, Aberdeen Proving Grnd (1975) (AD-B008322L) 247) L. Avrami et al, "Neutron Pulse Irradiation of Electroexplosive Devices", Defense Nuclear Agency Rept **DNA 4032P**, Vol 3, paper 5.4, pp 133-52, Proc 5th Symp, Nuclear Survivability of Propulsion and Ordnance Systems (1975) (SRD) (paper unclassified) 248) F.W. Davies et al, "The Hugoniot and Shock Initiation Threshold of Lead Azide", JChemPhys **64**, 2295 (1976) 249) V.J. Menichelli, "Effects of Nuclear Radiation and Elevated Temperature Storage on Electroexplosive Devices", JSpacecraft&Rockets **13**, 15 (1976) 250) R.A. Benham, "Simulation of X-Ray Blow-Off Impulse Loading on a Reentry Vehicle Aft End Using Light Initiated High Explosive", The Shock and Vibration Bulletin, No 46, Part 3 (1976), 183-89 251) R.A. Benham et al, "Application of Light Initiated Explosive for Simulating Blow-Off Impulse Effects on a Full Scale Reentry Vehicle", Ibid, No 47 (1976) 252) P.B. Higgins, "An Arc Source for Initiating Light Sensitive Explosives", Ibid, No 46 (1976), 191-96 253) L. Avrami & H.J. Jackson, "Effect of Long-Term Low-Level Gamma Radiation on Thermal Sensitivity of RDX/HMX Mixtures", PATR **4964** (1976) 254) L. Avrami et al, to be published; noted in Ref 257 255) P.J. Herley & P.W. Levy, "New Insights on the Thermal Decomposition of Ammonium Perchlorate from Studies on Very Large Single Crystals", Proc 8th Intern Symp on Reactivity of Solids, Gottenberg, Sweden (1976) 256) H.D. Fair & R.F. Walker, Edits, "Energetic Materials-1, Physics and Chemistry of the Inorganic Azides", Plenum Press, NY (1977) 257) L. Avrami & J. Haberman, "Sensitivity to Heat and Nuclear Radiation", in H.D. Fair & R.F. Walker, Edits, "Energetic Materials-2, Technology of the Inorganic Azides", Chapt 6, pp 199-247, Plenum Press, NY (1977) 258) P.W. Levy et al, "Formation of Color Centers in Ammonium Perchlorate by X-Ray Irradiation at Room Temperature", Radiation Effects **38**, 231-38 (1978) 259) F.H. Mathews, "A Computational Model Describing the Initiation of Silver Acetylide-Silver Nitrate Explosive by an Intense Light Source", The Shock and Vibration Bulletin (in press, 1979)

RADIATION GAUGING IN ENERGETIC MATERIALS

Radiation gauging pertains to the use of penetrating radiation, in particular as emitted from radionuclides or radioactive isotopes, for the measurement of particular properties of a material or system. Such properties may include density, thickness, mass, volume, composition, uniformity, etc. In addition to the use of nuclear radiation from radioisotopes instead of X-rays from machine generators, the other distinguishing difference from *Radiography* is that electronic detectors are employed instead of film to measure the transmitted or scattered radiation.

The primary advantages (Ref 5) of radioisotopic sources over machine sources of radiation are: 1) lower cost, 2) constant stable output, 3) elimination of maintenance and repair, and 4) they can be made very small, do not require a power source and are therefore portable and can be easily installed as part of an on-line process. These advantages must be weighed against the disadvantages of not being able to "turn off" the radioisotope source and of having no control over the source energy and intensity except for the initial choice. The use of electronic detectors such as G-M tubes, scintillation counters, nuclear diodes, etc, instead of film techniques offers two distinct advantages: 1) elimination of visual interpretation of film images with the accompanying human bias, and 2) the ease of coupling the electronic output signals to automatic electronic data processing equipment. The latter feature allows for a much greater degree of flexibility and sophistication in exploiting radiation gauging applications.

Of the radiations emitted from radioisotopes, we are concerned primarily with alpha (α), beta (β), gamma (γ) and neutron (n) in practical gauging applications. Because of their very low penetrability in most materials, α and β particles are of only limited interest, although there have been some applications of the latter to energetic materials as described later in this article. Gamma-rays have been used to the greatest extent because of their high penetration coupled with the ready availability of inexpensive radioisotopic sources at various energy levels. In more recent years, radioisotopic neutron sources

have been playing an increasingly important role in radiation gauging, in particular with measurements for organic materials containing hydrogen.

An excellent textbook reference discussing the general principles of radiation gauging has been prepared by Gardner and Ely (Ref 5). In this article, these principles will be reviewed briefly, and be followed by abstracts or summaries of published applications to energetic materials.

Charged Particle Gauging

The only charged particles used to any extent for radiogauging are alpha and beta particles, primarily because radioisotopic sources of these are readily available. To obtain other charged particles such as protons, deuterons, tritons and helium-3 nuclei, one must make use of machine sources such as accelerators. Alpha particles have been used least frequently for gauging because they have almost no ability to penetrate matter. A single sheet of writing paper will stop an alpha particle. As such, alpha sources are very difficult to encapsulate or contain and still allow the alpha radiation to be useful. The best technique at present is to incorporate the alpha emitter in a rare-earth glass matrix as microcapsules or microspheres. These ceramic microcapsules allow the alpha radiation to escape, but are themselves essentially chemically and physiologically inert, and are thus considered relatively safe in case of accidental internal ingestion by humans. Alpha-emitting radioisotopes which have been successfully encapsulated in this manner include polonium-210 (^{210}Po), plutonium-239 (^{239}Pu), and americium-241 (^{241}Am), with half-lives of 138 days, 24300 years and 458 years, respectively.

Because, as stated above, alpha particles are so easily absorbed by matter, their main uses in radiogauging have been to measure very thin film thickness and gas density, temp and pressure. Alpha particles lose their energy in matter primarily by ionization. The range of alpha particles in air, as a function of energy, can be estimated from the empirical expression (Ref 8):

$$R_{\alpha} = 1.24E - 2.62$$

where R_{α} = range in cm of air at 1 atm and 15°, and E = energy in MeV between 4–8MeV. Thus,

for the 5.5MeV alpha particle from ^{241}Am , approx 4cm of air is sufficient to absorb all of the energy by ionization. This high ionization potential of alpha particles in air (and gases in general) is the basis of the only important application of such radiation to energetic materials – namely as a *smoke detector* (Ref 19)

Beta particles are used extensively in radiogauging applications when measurements on small density thicknesses are desired. Density thickness is the product of density (g/cc) and thickness (cm) of a material and is usually expressed in units of g/cc. Beta particles are much more penetrating than alpha particles, but less penetrating than gamma rays, having a range of approx 1 mm in Al to 1000cm in air before losing all of their energy. The range of beta particles as a function of their energy can be approximated from the following two empirical expressions (Ref 8) where R = range in mg/cm² of any material and E = max range in MeV:

For $0.01 \leq E \leq 2.5 \text{ MeV}$, $R = 412E^{1.265 - 0.0954 \ln E}$
 For $E \geq 2.5 \text{ MeV}$, $R = 530E - 106$

The most common use of beta particles has been in the measurement of thickness of materials made in continuous sheets, eg, paper, plastics, and metal foils. Other important measurements include the packing density in cigarettes, the compn of hydrocarbon liquids, and the thickness of coatings on sheet materials by beta back-scatter

Gamma-Ray Gauging

Electromagnetic radiation from radioisotopes is the source of radiation that has been most extensively used in industrial and research type applications of radiogauges, and also for explosives technology. By selecting different radiation energies, one can obtain a source that will barely penetrate a few cm of air, several cm of metal, or, at the other extreme, a meter or so of concrete. Fig 1 is a sketch illustrating the generalized operation and components of a γ -ray gauge. It is seen that incident γ rays can be a) completely absorbed by, b) transmitted thru, or c) scattered out from a sample being measured. Both transmission and scattering of γ -rays have been and are being used in expls technology and their applications will be treated separately

Gamma-Ray Transmission

As illustrated in Fig 1, in a γ -ray transmission gauge the number of γ -rays from a source not absorbed by the sample is measured by an appropriate detector. The absorption process is exponential and is expressed by:

$$I = I_0 e^{-\mu \rho x} \quad (1)$$

where

I = radiation intensity with absorber x cm thick

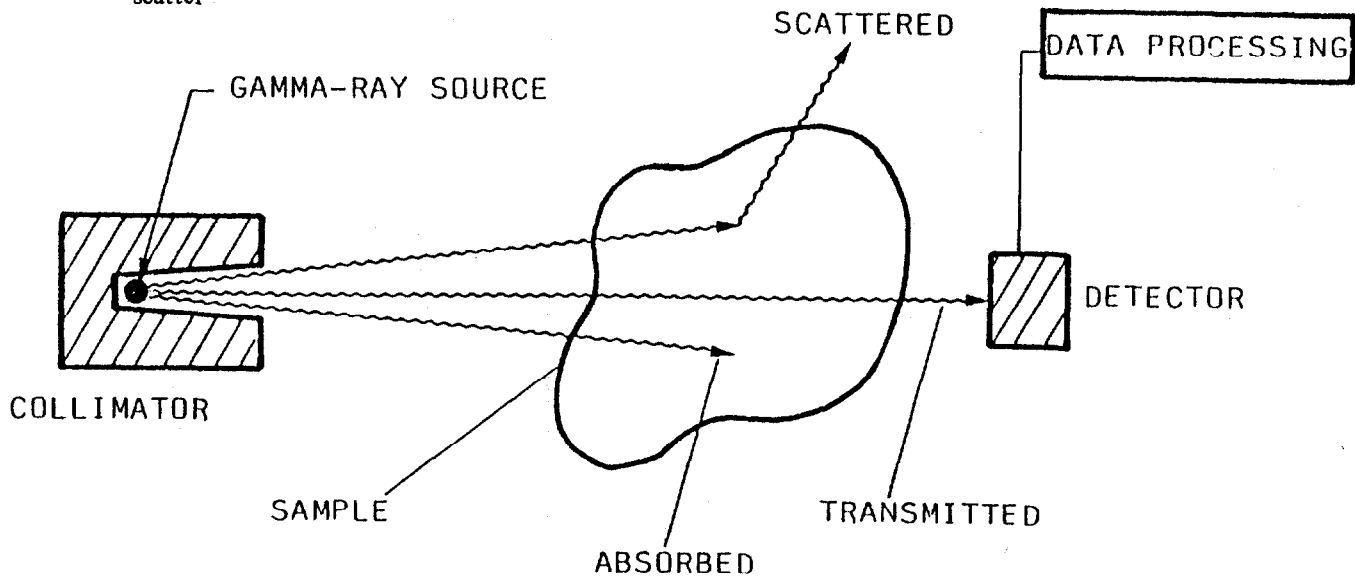

Fig 1 Generalized Concept of Gamma-Ray Gauging

and of density ρ grams/cc between source and detector

I_0 = radiation intensity with no absorber

μ = absorption coefficient of the particular γ -rays in units of cm^2/gram

B = buildup factor from scattered radiation

The factor B, in eq 1, refers to stray or scattered radiation that finds its way into the detector, and for transmission gauging this is generally undesirable since it decreases the signal-to-noise ratio ($B > 1$ when scattered radiation reaches the detector). The detection of this unwanted scattered radiation can usually be prevented either by collimating the source and detector arrangement, or by using γ -ray spectrometry to selectively detect only the unscattered radiation. Thus, for most γ -ray transmission gauging applications, $B=1$ and can be neglected

Referring to Fig 1, we have a radioactive source emitting γ -radiation of flux or intensity I_0 . In a transmission gauge, the material or item to be examined is interposed between the source and a gamma detector. The detector measures

the gamma flux I, which has passed thru the material and transposes it to a signal output proportional to I. Eq 1 tells us that if the density ρ is known, then one can measure the thickness x as a function of I. If the thickness is constant, one measures the density as a function of I

To obtain the optimum sensitivity in any given γ -ray transmission gauging application, the choice of the γ -ray energy is very important. Since most such applications are concerned with measuring for changes in density, the desired approach is to select a γ -ray energy which results in a large change in transmission (or absorption) for a small change in density. Since I and B are constants, eq (1) can be written as:

$$I = Ce^{-\mu\rho x}$$

Since ρ is the variable of interest, it is desired to know the change in I as ρ changes, and

$$\partial I / \partial \rho = -\mu x C e^{-\mu\rho x}$$

Differentiating with respect to μ ,

$$\frac{\partial(\partial I / \partial \rho)}{\partial \mu} = (x C e^{-\mu\rho x}) (\mu\rho x - 1)$$

Table 1
Commercially Available γ -ray Sources

Radionuclide	Symbol	Half-life	Principal γ -rays MeV	Intensity
Sodium-22	^{22}Na	2.62 y*	0.511 1.275	1.8 1.0
Cobalt-57	^{57}Co	270 d**	0.014 0.122	0.09 0.87
Cobalt-60	^{60}Co	5.26 y	1.173 1.332	1.0 1.0
Cadmium-109	^{109}Cd	453 d	0.014 0.088	— —
Barium-133	^{133}Ba	7.2 y	0.080 0.356	0.36 0.69
Cesium-137	^{137}Cs	30 y	0.662	0.85
Iridium-192	^{192}Ir	74.2 d	0.317 0.47	1.4 0.49
Americium-241	^{241}Am	458 y	0.060	0.36

Footnotes to Table 1:

* years

** days

$$\begin{aligned} \text{For optimum sensitivity, } \frac{\partial(\partial I/\partial \rho)}{\partial \mu} &= 0, \text{ and} \\ \mu \rho x - 1 &= 0 \\ \text{Thus, } \mu &= 1/\rho x \end{aligned} \quad (2)$$

μ is a constant for any material for a specific γ -ray energy and is either tabulated in the literature for many common materials or can be easily calcd for a material, such as an expl, from its atomic compn. Thus, the optimum γ -ray energy for a particular gauging application can be determined by first calculating the absorption coefficient, μ , from the density and thickness parameters, and then selecting a γ -emitting radionuclide with an energy most closely providing the desired value for μ . The more common γ -emitting radionuclides, commercially available as sources for gauging, are listed in Table 1. Included for each radioisotope is the nuclear half-life energies and intensities of the principal γ -ray emissions; intensities are expressed as fractions of γ -rays emitted of the particular energy for one disintegration or decay of the parent radionuclide

In Tables 2 and 3, the γ -ray absorption coefficients for individual elements needed to calculate μ values for most expl compds and compns are listed for the ranges 0.015–0.125MeV and 0.30–1.25MeV, respectively. Also included are other elements used in ammo such as in containers and shell walls. Specific energy values have been selected to coincide as closely as possible to γ -ray energies from the available radionuclides listed in Table 1, eg, 1.25MeV is the mean value for the two ^{60}Co γ -rays and 0.662MeV is the emission from ^{137}Cs . From the absorption coefficients for individual elements, total μ values can be calcd for compds or compns based on gram-molecular and formula wt proportions. These are tabulated for some common expls and compns in Tables 4 and 5 (Ref 12); also included are density values

It is seen that for expls that are all organic ie, contain only C, H, N and O, μ values are essentially independent of compn at γ -ray energies at 0.060MeV and higher. It is only at very low energies, such as 0.015MeV, that compn may significantly affect the absorption coefficient of organic expls. On the other hand, with expls containing heavier elements, in particular Pb and Hg, μ values are very significantly higher at the lower energies but become less so with higher

energies. At 1.25MeV, γ -ray absorption coefficients for all expls are of the same magnitude

As a simple example of how one would use Tables 1–5 for design of a γ -ray transmission gauge, let us select the best available radionuclide source to measure density changes in a cylinder of Comp B, 6cm in thickness. From eq (2), the γ -ray absorption coefficient for maximum sensitivity is $1/\rho x$ or $1/1.67(6) = 0.0998$. In Table 5 we find that for Comp B the γ -ray energy most closely related to this μ value is 0.40MeV and in Table 1 we note that the 0.356 γ -ray of ^{133}Ba will provide the most suitable source

With regard to the selection of the optimum source from the choices offered in Table 1, the question of the half-life must also sometimes be considered. This is because, for a given γ -ray emission rate, the physical size of the source is directly related to its half-life, ie, the longer the half-life, the larger the source. Thus, for the above example, if 7.2 y ^{133}Ba was unsuitable because of its physical size, then 74.2 d ^{192}Ir , with an average γ -ray energy of 0.36MeV, would be another choice

Gamma-Ray Scattering

Gamma-ray gauging or inspection using the photon scattering technique is based on the phenomenon that a portion of the γ -rays in the incident beam are scattered away from the beam by material in its path (see Fig 2). This interaction, known as Compton scattering, is the principal mode of interaction between γ -rays and target materials for energies between 200 keV and several MeV. The incident γ -ray is scattered by a free or loosely bound electron in the material. From the conservation of energy and momentum, the γ -ray imparts some of its energy to the electron and emerges from the interaction with less energy. The energy of the scattered γ -ray, E'_γ , is dependent upon the incident γ -ray energy E_γ and the scattering angle θ via the equation

$$E'_\gamma = E_\gamma [1 + \alpha(1 - \cos\theta)] \quad (3)$$

where $\alpha = E_\gamma/mc^2$ and $mc^2 = 511\text{keV}$, the electron rest mass energy. Thus, a small loss of energy is associated with a small angular deflection, while larger energy losses occur at larger deflection angles. The maximum energy loss occurs when

Table 2
 γ -Ray Absorption Coefficients for Elements, 0.015–0.125MeV
 cm^2/g

Element	At Wt	0.015	0.060	0.080	0.100	0.125
H	1.01	0.375	0.326	0.309	0.295	0.280
B	10.81	0.480	0.159	0.147	0.139	0.131
C	12.01	0.778	0.175	0.162	0.153	0.144
N	14.01	1.200	0.180	0.164	0.154	0.145
O	16.00	1.800	0.189	0.168	0.156	0.147
Al	26.98	7.910	0.268	0.197	0.169	0.154
S	32.06	15.60	0.395	0.252	0.201	0.176
Cl	35.45	17.40	0.438	0.270	0.206	0.177
K	39.10	25.60	0.549	0.317	0.231	0.194
Fe	55.85	58.90	1.21	0.599	0.372	0.284
Ni	58.71	71.1	1.48	0.720	0.440	0.330
Cu	63.54	76.7	1.56	0.757	0.459	0.341
Zr	91.22	19.90	3.67	1.710	0.958	0.668
Sn	118.70	46.5	6.58	3.00	1.65	1.122
Ba	137.40	63.9	8.42	3.84	2.16	1.459
Hg	200.60	177.0	4.65	2.27	5.51	3.690
Pb	207.20	117.0	3.55	1.66	5.47	3.695
U	238.03	63.9	6.96	3.35	1.91	2.34

Table 3
 γ -Ray Absorption Coefficients for Elements, 0.30–1.25MeV
 cm^2/g

Element	At Wt	0.30	0.40	0.50	0.66	1.25
H	1.01	0.212	0.189	0.173	0.152	0.115
B	10.81	0.0986	0.0883	0.0806	0.0710	0.0654
C	12.01	0.107	0.0953	0.0873	0.0767	0.0577
N	14.01	0.107	0.0955	0.0869	0.0766	0.0576
O	16.00	0.107	0.0957	0.0870	0.0758	0.0516
Al	26.98	0.104	0.0927	0.0844	0.0733	0.0570
S	32.06	0.109	0.0968	0.0879	0.0768	0.0540
Cl	35.45	0.105	0.0930	0.0844	0.0732	0.0540
K	39.10	0.108	0.0949	0.0858	0.0752	0.0540
Fe	55.85	0.110	0.0940	0.0841	0.0735	0.0543
Ni	58.71	0.115	0.0973	0.0866	0.0752	0.0557
Cu	63.54	0.112	0.0940	0.0834	0.0725	0.0533
Zr	91.22	0.131	0.102	0.0859	0.0723	0.0523
Sn	118.70	0.159	0.112	0.0914	0.0733	0.0518
Ba	137.40	0.186	0.124	0.0969	0.0763	0.0518
Hg	200.60	0.364	0.210	0.146	0.100	0.0580
Pb	207.20	0.378	0.220	0.152	0.107	0.0612
U	238.03	0.509	0.286	0.193	0.135	0.0615

Table 4
 γ -Ray Absorption Coefficients for Explosive Compounds and Compositions, 0.015–0.125MeV
cm²/g

Explosive	Density	0.015	0.060	0.080	0.100	0.125
	g/cc					
HMX	1.90	1.368	0.187	0.169	0.159	0.149
RDX	1.82	1.355	0.185	0.168	0.157	0.148
TNT	1.59	1.266	0.183	0.166	0.156	0.147
NC ^a	1.66	0.996	0.184	0.169	0.159	0.150
NG	1.59	1.480	0.186	0.168	0.157	0.147
Comp B (60/40) ^b	1.67	1.333	0.186	0.169	0.158	0.149
Amatol (80/20) ^c	1.46	1.470	0.191	0.173	0.161	0.152
Lead Azide	4.80	82.70	2.552	1.216	3.900	2.640
Lead Styphnate	3.02	75.10	2.40	1.220	3.516	2.460
Mercury Fulminate	4.00	123.9	2.92	1.630	3.890	2.617
Tritonal (80/20) ^d	1.70	2.61	0.202	0.174	0.156	0.149
KDBNF ^e	1.98	1.31	0.185	0.168	0.157	0.148
Delay Comp (Type 2) ^f	3.00	—	3.52	1.644	0.952	0.665
Black Pdr ^g	1.88	29.21	0.310	0.218	0.181	0.163

Footnotes to Table 4:

a - (C₁₂H₁₄N₆O₂)_n

b - RDX/TNT

c - NH₄NO₃/TNT

d - TNT/Al

e - KC₆H₄N₄O₆

f - 59% BaCrO₄, 14%

KClO₄, 9% Zr/Ni

(70/30) alloy, 17%

Zr/Ni (30/70) alloy

g - 74% KNO₃, 16% C, 10% S

Table 5
 γ -Ray Absorption Coefficients for Explosive Compounds and Compositions, 0.30–1.25MeV
cm²/g

Explosive*	Density	0.30	0.40	0.50	0.66	1.25
	g/cc					
HMX	1.90	0.110	0.0981	0.0894	0.0783	0.0566
RDX	1.82	0.109	0.0971	0.0885	0.0775	0.0560
TNT	1.59	0.108	0.0970	0.0884	0.0773	0.0550
NC	1.66	0.111	0.0992	0.0906	0.0796	0.0593
NG	1.59	0.108	0.0967	0.0880	0.0770	0.0545
Comp B (60/40)	1.67	0.110	0.0979	0.0892	0.0782	0.0565
Amatol (80/20)	1.46	0.112	0.0998	0.0908	0.0795	0.0568
Lead Azide	4.80	0.297	0.182	0.132	0.0970	0.0596
Lead Styphnate	3.02	0.278	0.174	0.128	0.0956	0.0598
Mercury Fulminate	4.00	0.285	0.174	0.127	0.0922	0.0566
Tritonal (80/20)	1.70	0.108	0.0966	0.0881	0.0770	0.0562
KDBNF	1.98	0.109	0.0972	0.0886	0.0776	0.0561
Delay Comp (Type 2)	3.00	0.134	0.103	0.0876	0.0734	0.0517
Black Pdr	1.88	0.108	0.0955	0.0868	0.0760	0.0541

*see footnotes under Table 4

photons are scattered 180° , directly back into the incident beam. The probability for a γ -ray to be scattered thru a particular angle is a clearly defined function of the incident beam energy and the angle. Also, for γ -ray energies in excess of about 0.1MeV, the number of scattered photons is independent of the material compn and depends almost entirely on the electron density of the scattering target. Since the electron density of a material is almost proportional to its actual density (mass per unit volume), in particular for materials with low atomic numbers such as expls, Compton scattering is very sensitive to density charges in such materials

Although γ -ray scattering has not been applied as universally as the transmission principle, there has still been significant use of the scattering approach to radiation gauging. Its most publicized application has been in the measurement of in-place soil density. Other industrial applications include the measurement of sheet metal thickness, the monitoring of fluid level, the measurement of material density, and the analysis of two-component materials. In the expls area, applications of γ -ray scattering gauging have included determination of charge weight in proplnt cartridges and measurement of voids and defects in cast-loaded artillery shells

Neutron Gauging

Neutron gauging makes use of the slowing down (moderation), scattering and attenuation of neutrons when they impinge on or collide with particular elements, especially hydrogen. This general technique has been used most extensively, in the past, on samples of very large or almost infinite size, eg, soil, concrete, coal, etc for the measurement of moisture or hydrogen content

The interaction of neutrons for the measurement of moisture or hydrogeneous content on relatively small size samples, of an order suitable for lab purposes or for in-plant process and quality control, has been the subject of only a few investigations (Ref 7). In the case of small sample size, the approach and necessary equipment are closely related to gamma-ray gauging and thus, when the source of radiation is neutrons, the technique can be appropriately referred to as neutron gauging

A simplified illustration of neutron gauging is shown in Fig 2. The essential components are an isotopic neutron source, the sample to be measured, a thermal neutron detector and appropriate nuclear counting instrumentation to record changes in thermal neutron count rates. Neutron gauging can be performed in two distinct modes. If a bare or unmoderated isotopic

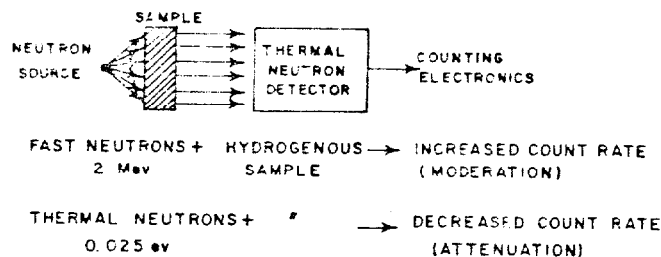

Fig 2 Simplified Illustration of Neutron Gauging

neutron source is used, the neutrons impinging on the sample will be essentially fast with an average energy of 2MeV or greater depending on the particular source. In this case, hydrogen in the sample will moderate or slow down a portion of the neutrons to thermal energies and the detector will show an increased count rate due to the sample. On the other hand, if the neutrons are first moderated, eg, by surrounding the bare source with sufficient paraffin or polyethylene, the majority of the neutrons diffusing into the sample will be thermalized. In this case, hydrogen in the sample will scatter the neutrons and the detector will show a decreased or attenuated count rate. In the idealized version of each type of gauge we assume a pure fast source of neutrons for the "moderation" mode, a pure thermal source for the attenuation mode, and for both modes a detector sensitive only to thermal neutrons. None of these ideal conditions is actually met in practice

The important properties of various elements to fast and thermal neutrons as they relate to neutron gauging are given in Table 6

The first five elements constitute organic compds and these are of most interest for neutron gauging applications to organic expls. The remaining elements are either common impurities (Na, Cl) or comprise the metal walls for the encasement of energetic materials, eg, cartridges and shells

Values in the third column of Table 6 are the

Table 6
Fast and Thermal Neutron Properties of Elements

Element	Mass No.	No of Collisions to Thermalize ^a	Density	Thermal Neutron Cross-sections, cm ⁻¹		
				Σ_s	Σ_a	Σ_t
H	1	18	1.00 ^b	30	0.2	30.2
C	12	115	1.00 ^b	0.2	0.0002	0.2
N	14	134	1.00 ^b	0.4	0.1	0.5
O	16	152	1.00 ^b	0.2	0.00001	0.2
S	32	297	1.00 ^b	0.02	0.01	0.03
Na	23	214	2.20 ^c	0.2	0.03	0.2
Al	27	253	2.70	0.1	0.01	0.1
Cl	35	325	2.20 ^c	0.6	1.3	1.9
Fe	56	520	7.86	0.9	0.2	1.1
Cu	64	587	8.92	0.6	0.3	0.9
Pb	207	1900	11.3	0.4	0.06	0.5

Footnotes to Table 6:

- a - From 2MeV to 0.025ev
 b - Assumed for organic compds
 c - Value for NaCl

approx number of collisions with the particular atom for a 2MeV neutron to be slowed down to thermal energy (0.025ev). For samples of small size or thickness, where absorption of thermalized neutrons can be neglected, this property is a measure of the relative moderating ability of different elements for fast neutrons. Thus the fractional loss in energy when a neutron collides with an atom is greatest for the hydrogen atom. Therefore, by passing a beam of fast neutrons thru a series of materials of varying hydrogen density (with all other parameters equal), a relationship should be observed between hydrogen content and measured thermal neutron intensity; this is the basis of a fast neutron moderation gauge

The density and thermal neutron cross-section values in Table 6 pertain to the thermal neutron attenuation gauging process. In this method, advantage is taken of the large thermal neutron scattering cross-section of hydrogen as compared to most other elements. In its simplest form, when a beam of thermal neutrons of intensity I_0 traverses a sample of thickness x , the intensity I of neutrons measured by a thermal neutron detector will be

$$I = I_0 e^{-\Sigma_t x}$$

where Σ_t is the total macroscopic cross-section ($\Sigma_s + \Sigma_a$, scattering plus absorption) per unit

volume of the sample for the incident neutrons

In computing the cross-sections for the first five elements, a density of 1.00 was arbitrarily assumed for organic compds. The total cross-section for hydrogen is at least 30 times greater than for any other element listed in Table 6. Thus, it is seen that in both fast or thermal neutron gauging applications, with materials comprised of the more common elements, variations in hydrogen content (or density) will result in the greatest effect on the original neutron signal. In practice it has been found (Ref 20) that fast neutron gauging is more sensitive in applications where the hydrogen content or density is to be measured in relatively larger samples, eg, moisture in bulk materials, whereas thermal neutron gauging is the preferred method for samples or objects of small dimensions, eg, determination of expl charge weight in sealed cartridges or primers

The most important component of a neutron gauge is the source of neutrons. Radioisotopic neutron sources are radioactive isotopes which either in combination with other stable elements or by their own decay emit neutrons. The attractiveness of these encapsulated sources is their small size and weight and complete absence of operational problems. Until about 1970 the most widely used of such sources has been an

intimate mixt of a light element such as beryllium with an intense alpha particle emitter such as polonium-210, radium-226, plutonium-238, plutonium-239 or americium-241. The nuclear reaction for the production of neutrons, generally termed an (α , n) reaction, is represented as:

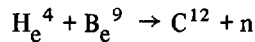

The neutrons produced are fast with average energies in the range of 3–5MeV

Practical, inexpensive, small-sized sources of this type can be obtained with neutron outputs up to $\sim 10^8$ per sec. Above these outputs, the (α ,n) sources start to lose the advantage of small physical size and in addition to the higher initial cost, the problem of heat dissipation from the capsules arises

Radioisotopes that decay by spontaneous fission with the direct accompanying release of neutrons are usually associated with the natural elements of uranium and thorium and the man-made element plutonium. However, the rate of decay of these elements by fission is so slow that it is only by incorporating them into large nuclear piles or chain reactors that they can be utilized as intense neutron sources. In the US Dept of Energy National Transplutonium Program, small quantities of elements heavier than plutonium are produced for basic research studies and to discover new elements with useful properties. One of these new elements, californium-252 (^{252}Cf), is unique in that it emits neutrons in copious quantities over a period of years by spontaneous fission

^{252}Cf is made by bombarding plutonium-239 (^{239}Pu) with neutrons in a very high intensity nuclear reactor. Elements of higher atomic number are built up by successive neutron captures. Thirteen successive neutrons must be added to each nucleus of ^{239}Pu to convert it to ^{252}Cf . The important nuclear properties of this new element are:

Effective half-life	2.65 years
Average neutron energy	2.35MeV
Neutron emission rate	2.34×10^{12} neutrons/sec/gram
Decay heat	38.5 watts/gram

Encapsulated ^{252}Cf neutron sources are currently available commercially in quantities ranging from 1 microgram to 20 milligrams — equivalent in neutron output from 2×10^6 to

4×10^{10} neutrons per sec

With the availability of small, relatively intense radioisotopic neutron sources, radiation gauging with neutrons has become an important technique in the inspection of energetic materials. Applications have included nondestructive measurement of moisture in expls, determination of charge weight and fill height in sealed ammo cartridges and in detection of concealed expls

Specific Applications of Radiation Gauging

Detection of Faults in Black Powder Safety Fuses (Ref 14)

During the mechanical loading of the fuse core, small sections more than 2mm long are sometimes not filled with BlkPdr due to malfunction of mechanical parts. These faults are only observed when they interrupt the propagation of the flame when the fuse is ignited. These undetected faults can cause safety problems to workers in the field and also considerable loss of time

The radiogauging technique consists of an encapsulated strontium-yttrium (^{90}Sr – ^{90}Y) source, emitting 2.27MeV beta particles, and an ion chamber at opposite ends of a collimator. The safety fuse travels thru the collimator perpendicular to the collimated beam of beta particles. The intensity of the beam that reaches the ion chamber increases when a faulty portion of the fuse cord passes thru the collimator between source and detector, and a higher current output is therefore generated in the chamber. This higher output current is compared to an external current equivalent to that produced when a faultless fuse passes thru. The strength of the ^{90}Sr – ^{90}Y source is approx 50 millicuries

Measurement of Blast Wave Density (Refs 3, 9 & 11)

The use of beta particle gauging is described for the measurement of blast wave density from the detonation of large charges of high expl on the surface, eg, 500-ton TNT spherical and hemispherical charges. The basic principle of the gauge is the measurement of the varying absorption of beta particles caused by density changes

between a radioactive source and a detector as a blast wave passes between them. The radioactive source detector unit, amplifier and power supplies were mounted in a rigid metal structure located at the blast site. The radioactive source was mounted flush on one of the inside walls of the structure and the detector unit was mounted directly opposite in the other inside wall, alongside a pressure gauge which monitored side-on pressure. These two wall surfaces were flat and parallel, 7.6cm apart, and aligned along a radial direction from ground zero, such that the shock wave propagating out from ground zero passed between the two surfaces and hence between the source and detector. Promethium-147, a pure beta emitter with a maximum energy of 0.23MeV and a half-life of 2.6 years, was selected as the optimum source and a plastic scintillator was used for the detector. The intensity or count rate of the beta particles at the scintillator was observed to be a function of the air density between the source and detector as the blast wave passed over the device. The gauge was calibrated by means of a round aluminum disc 0.9m in diam containing 20 circular holes into which were inserted various thicknesses of aluminum and mylar sheets, either singly or in combinations, to give the required real density

values. These ranged from 0 to 25mg/cm², which assuming a nominal air density of 8mg/cm² (air density in mg/cm³ x 7.6cm) gives a calibration range from ambient density up to four times ambient — a range sufficient for such measurements

Measurement of Solid Propellant Burning Rate (Refs 1, 2 & 4)

Researchers at Purdue University (Refs 2 & 4) have developed an exptl system for the direct and continuous measurement of solid rocket proplnt burning rates using γ -ray gauging. A sample of solid proplnt is bonded to a holder with an attached shaft which moves the proplnt sample within a two-dimensional rocket motor. The flat burning surface of the proplnt sample recedes normally as a servomechanism moves the proplnt in a direction opposite to the receding proplnt surface. The servomechanism operates in such a manner that the burning surface is maintained at a fixed position within the rocket motor; thus the direct measurement of the velocity of the shaft yields the burning rate

The servomechanism incorporates a radioactive isotope feedback transducer system for detecting the position of the burning surface.

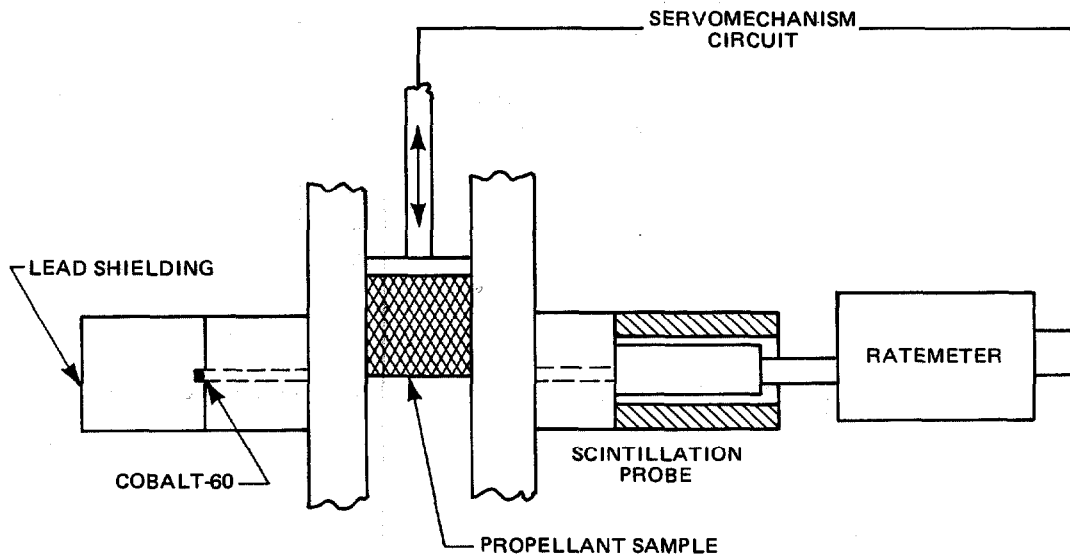

Fig 3 Gamma-Ray Feedback Transducer System for Propellant Burning Rate Measurement

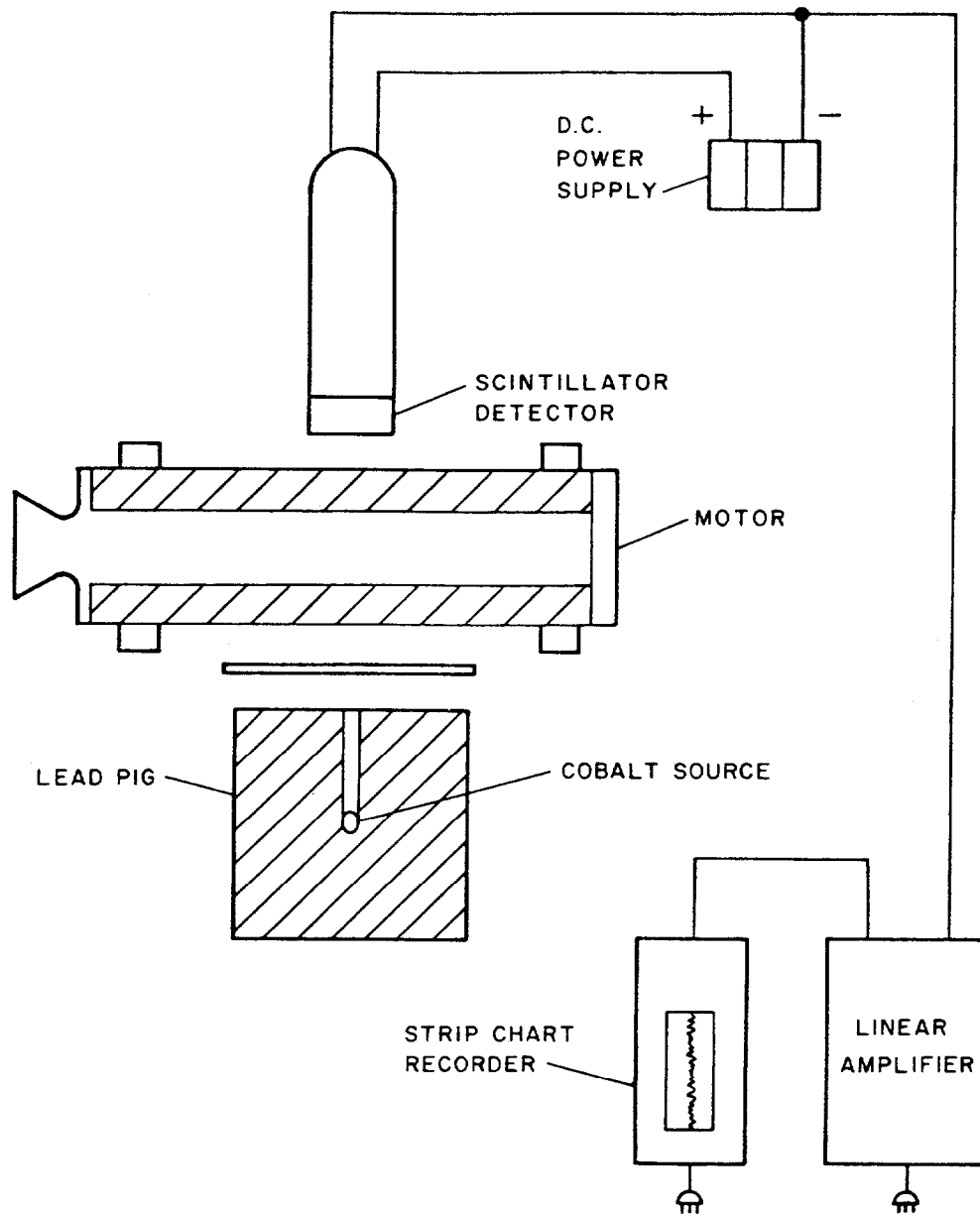

Fig 4 Gamma-Ray Transmission Gauge for Burning Rate Measurement in Rocket Motors

A collimated beam of γ -rays (Fig 3), provided by a shielded 2.5-curie source of Cobalt-60, is transmitted thru the rocket motor walls and is transformed into an electrical feedback signal by a γ -ray detector coupled to a linear rate meter. As the proplnt burns, the intensity of the collimated beam increases due to the difference in the density of the solid proplnt and its combination products. The intensity of the emitted collimated beam of γ -rays that strike the scintillation probe after passing thru the combustion chamber is a function of the density and thickness of the material thru which the γ -rays pass. Since the walls of the combustion chamber remain fixed, their attenuation is constant. The attenuation of the γ -rays by the combustion products of the sample may also be neglected since the attenuation of the γ -rays is chiefly a function of material density. Thus, the emitted beam intensity is a function only of the position of the proplnt sample because the motion of the proplnt provides a variable attenuation of the emitted energy

The γ -rays emitted by the source are collimated by a 1/8" diameter hole drilled thru a lead block (Fig 3). The collimated beam passes thru the rocket motor and strikes another collimator, 0.050" square, in the end of the lead shield housing the scintillation probe. The lead shield for the probe is provided to exclude background and scattered radiations which may lead to erroneous signals. The two collimators are different in diameter to allow for misalignment between the two collimating fixtures. The scintillation probe coupled with a linear rate meter provides a feedback signal by monitoring the intensity of the emerging γ -ray beam. Additional details on the design and operation of the servomechanism circuit and components, and for calibration of the system to give accurate burning rates are described in Refs 2 & 4

This measurement technique has been demonstrated to be an effective exptl system for measuring burning rates of solid rocket proplnts under conditions closely simulating actual rocket motor conditions. In addition, the servomechanism measurement technique possesses the following features: 1) the burning rate measurements are obtained directly, 2) the burning rate measurements are continuous allowing an instantaneous burning rate to be correlated with its

true motor chamber pressure, 3) the measurement technique does not influence the combustion gas flow field, and 4) the reduction of the burning rate data from the oscillogram is extremely simple and rapid

Another application of γ -ray transmission to the measurement of burning rate of rocket proplnts again uses ^{60}Co to monitor for mass flow within the motor during the combustion process under static firing conditions (Ref 1). The capsule containing the radioactive cobalt is housed in a lead cylinder, 11" long by 11" diam, in a bore drilled directly from the center of the top to a distance 5 1/2" into the cylindrical section. A removable lead plug was machined to provide additional shielding for personnel. During the tests, the lead cylinder is placed directly under the static firing facility, the lead plug is removed, and a steel barrier is placed between the cylinder and the rocket motor to protect the capsule in the event of a blow-up or misfire. The motors are placed longitudinally above the lead cylinder such that the collimated beam passes thru the barrel section of the motor at approx the center (Fig 4)

The radiation passing thru the motor is picked up by a scintillation detector and the signal is fed to a strip chart recorder thru associated electronics. The linear attenuation (or absorption) coefficient (μ) for any proplnt formulation can be determined exptly by the direct measurement of the decrease in the intensity of an attenuated beam of γ -radiation corresponding to the successive addition of incremental proplnt thicknesses placed in the path of the beam. By plotting the relative intensity (percent) of the attenuated beam on a log scale against the proplnt thickness on a linear scale, μ can be determined from eq (1) ($I = I_0 e^{-\mu\rho x}$)

For a grain with a circular cylindrical perforation, the burning rate is computed from the exptl data by differentiating eq (1) with respect to time, t:

$$\frac{dI}{dt} = -\mu\rho I_0 e^{-\mu\rho x} \frac{dx}{dt}$$

$$\frac{dx}{dt} = \frac{e^{\mu\rho x}}{\mu\rho I_0} \frac{dI}{dt}$$

$$r_b = -\frac{1}{2} \frac{dx}{dt} = \frac{e^{\mu\rho x}}{2\mu\rho I_0} \frac{dI}{dt} \quad (3)$$

where r_b = burning rate

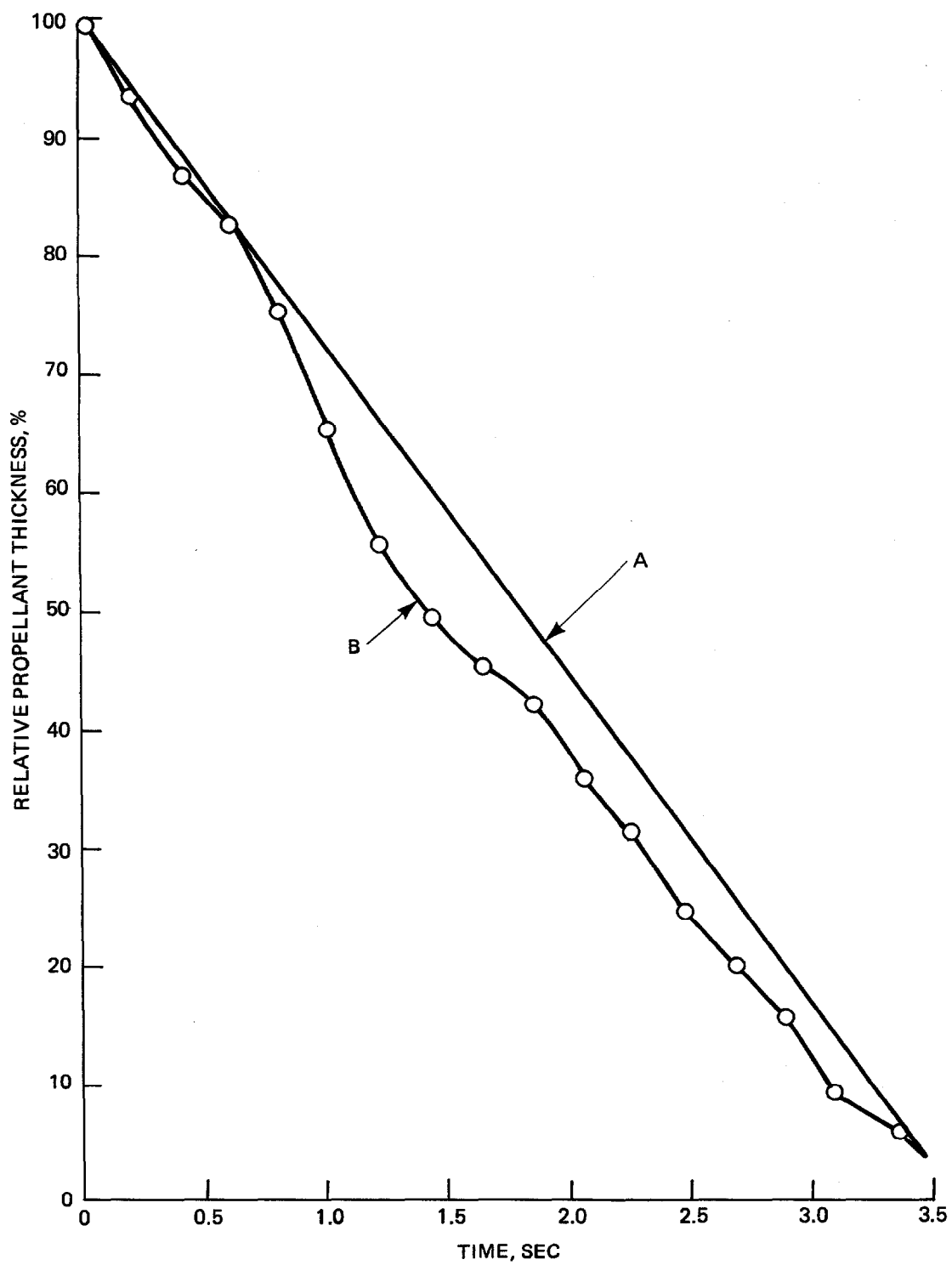

Fig 5 Relative Propellant Thickness vs Burning Time Using γ -Ray Transmission Gauge

A typical set of data from a static rocket motor firing is shown in Fig 5. Values for relative proplnt thickness as a function of time are obtained from the intensity readings on the strip chart recorder previously calibrated for the same proplnt compn. For any given time, the slope dI/dt can be substituted into eq (3) to calculate the burning rate

In Fig 5, curve B is the observed firing data; curve A is drawn for comparison purposes and would be the curve obtained from a constant burning rate over the same period of time. The plots of proplnt thickness vs time are indicative that the burning rate is not constant during burning time, but that variations do occur

Scanning γ -Ray Densitometer System for Detonators (Ref 10)

Two of the most important parameters determining detonator performance are the density and height of the expl increments. Typical detonators have three increments: an ignition mix (such as NOL-130), a booster (such as Pb Azide), and an output charge (such as RDX). Particularly in small detonators each increment is close to its critical density and height, and so relatively small variations can result in great changes in performance. At PicArnsn a scanning γ -ray densitometer was developed for studies on the

effects of dimension and density on performance, and also for possible use as a routine quality control test with the operation of mass production lines

The original prototype gauge was designed for testing M-55 detonators. In these units, the density of the Pb Azide layer is about 3.43g/cc, and the equivalent thickness is about 0.30cm. From the relationship for optimum sensitivity, $\mu\rho x = 1$, the optimum γ -ray energy would be 0.22MeV. Higher energies would be desirable for larger detonators, and lower ones for lower density components such as RDX

An iridium-192 (^{192}Ir) source with an energy peak at 0.317MeV was the available source closest to the desired energy. It was used in the form of a 1 mm x 1 mm foil mounted within a 1/4" outside diameter stainless steel tube (Fig 6). Major γ -ray peaks in the ^{192}Ir spectrum occur at 0.066, 0.317, 0.468 and 0.613MeV, with the most intense one at 0.317MeV. For this application, discriminators on the electronics were set to count only the 0.317MeV peak

Because of the small size of M-55 detonators, 0.146" x 0.142" (0.37 x 0.36cm), very fine collimation of the incident γ -rays is required to achieve the desired spatial resolution. To accomplish this a lead collimator with 0.002" high, 0.10" wide slit, and a scanning system was built

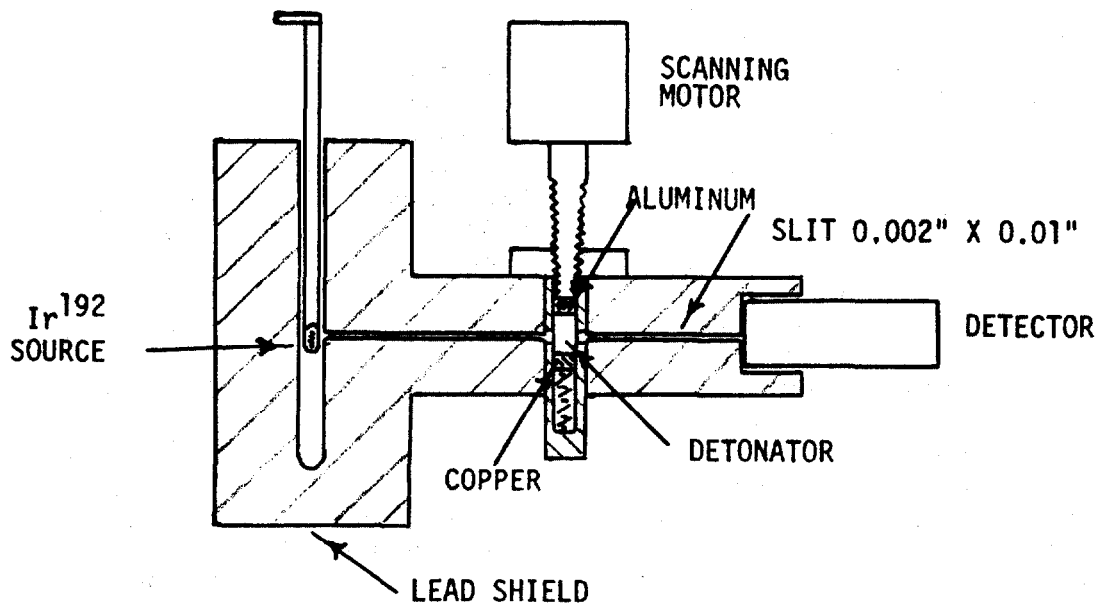

Fig 6 Sketch of γ -Ray Density Scanner

Duplicate Scans

M-55 Detonator

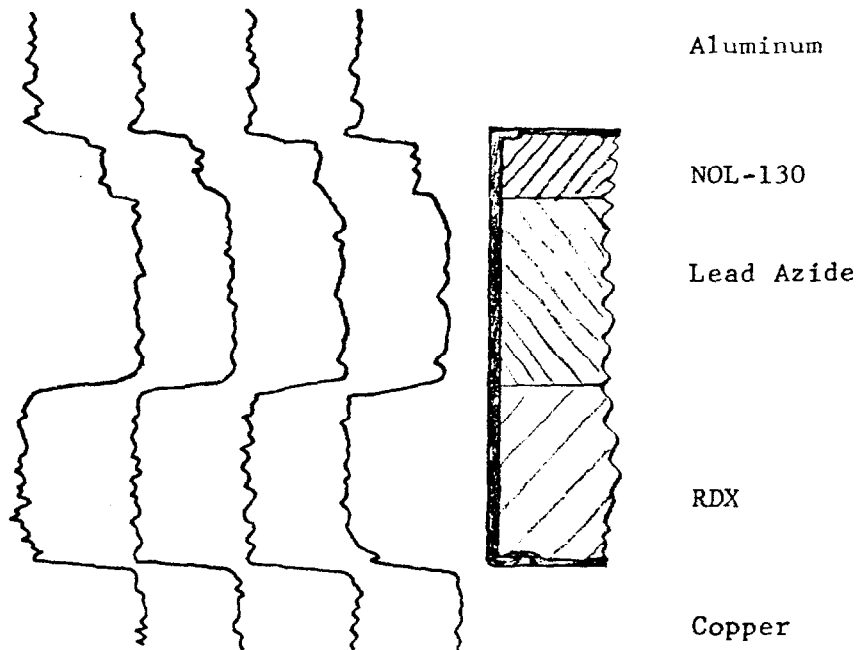

Fig 7 Typical γ -Ray Densitometer Scan of an M-55 Detonator

as shown in Fig 6. This allowed the source to be raised into position for measurement, or stored in its shipping pig when not in use. The scanning motor turned at such a rate that $1/32''$ ($0.03125''$) was traversed each minute; other scanning speeds could be used as required to obtain the desired counts/inch

The collimator design is a compromise between having a large enough thickness of lead to block the radiation not passing thru the sample, and positioning the sample close enough to the source to obtain a reasonable counting rate. With the 6" collimator length used, a counting ratio of 5:1 was obtained for a copper sample compared to background. Before scanning a detonator, correct positioning of the source was obtained by maximizing the transmitted gamma beam with the rate meter. The proper positioning of the source is of prime importance to avoid longer counting times as well as spectrum distorting effects from the decreased ratio of primary beam to background intensity. An adjustable screw and lock nut are used to hold the source in proper position during scanning

The detector unit was a 2" x 2" cesium iodide

scintillation assembly which gave the required sensitivity and resolution of energy peaks. With this detector, background was minimized and satisfactory measurements were obtained using a pulse height discriminator to count only the pulses in the range from 0.24 to 0.40MeV, which include the ^{192}Ir 0.317MeV peak

To improve accuracy, the background during measurements was calcd from counting rates on copper and aluminum standards with the beam in measuring position. Under these conditions, background was about 15% of the sample rate. A permanent record of the rates during detonator scans was made with a strip chart recorder connected to a nuclear rate meter; a more accurate record was also made of the counts per unit time with a high speed printer coupled to a multichannel analyzer

Typical scans of an M-55 detonator are reproduced in Fig 7, showing the rate meter plots corresponding to the γ -ray transmission profile thru the detonator. Starting with copper as a standard, a large increase in transmission is obtained as the beam transverses thru the RDX layer, and a corresponding decrease occurs thru

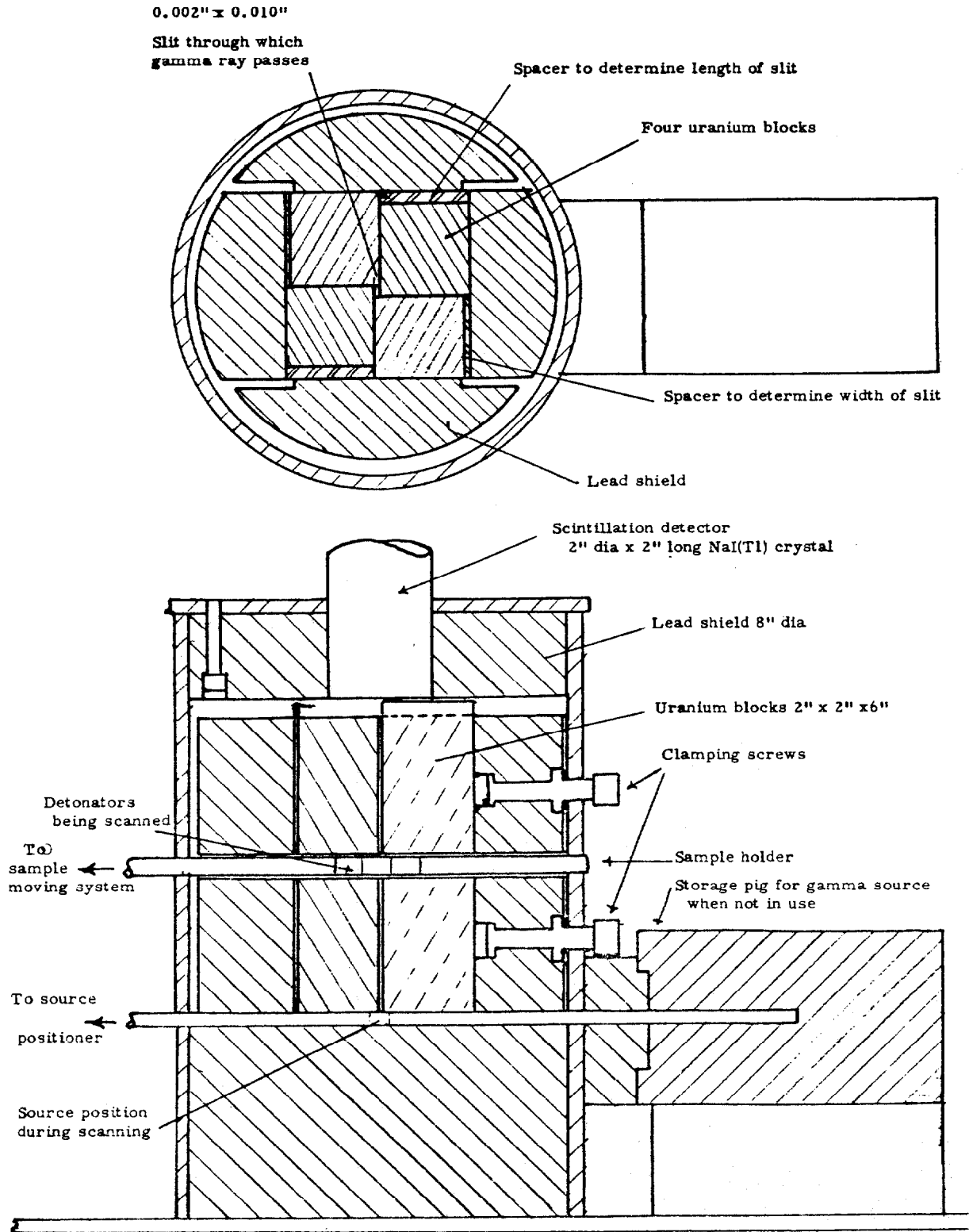

Fig 8 Improved γ -Ray Scanning Gauge for Detonators

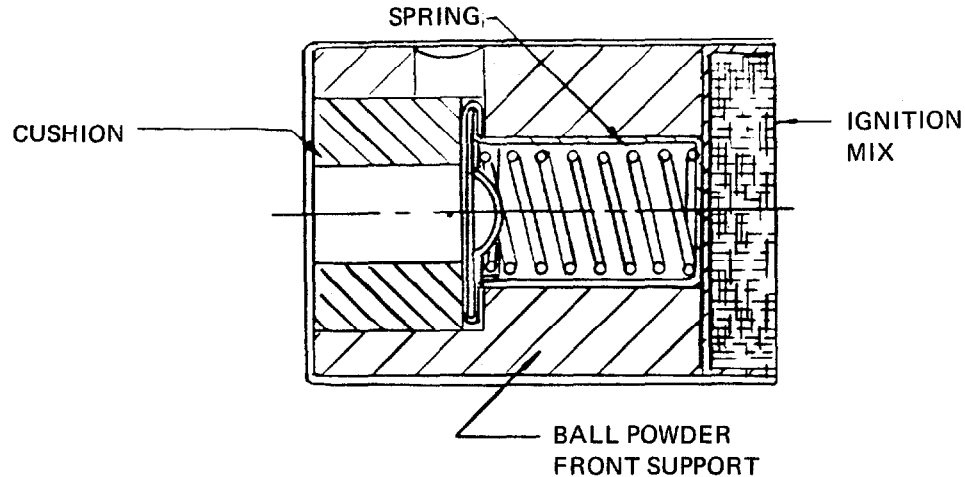

Fig 9 Electrical Ignition Element

the higher density Pb Azide layer. The interface between Pb Azide and NOL-130 is also apparent although these two materials are of almost equal density. For this particular unit, the NOL-130 layer is of slightly lower density than the Pb Azide. Transmission thru aluminum is used as a second standard

The distances between interfaces as read from the rate meter plots are used as a measurement of the thickness of each layer while the densities are calcd from the actual counts obtained on the high speed digital printer. Interface locations can be measured to an accuracy of $\pm 0.002''$ ($\pm 5\text{mm}$) and densities to a precision of $\pm 0.2\text{g/cc}$ for Pb Azide and NOL-130. From measurements made on large numbers of detonators, specifically loaded for this work, it was found that relatively large changes in column height and density for Pb Azide and NOL-130 occurred with small changes in loading pressure. The accurate control of loading pressure was emphasized from this work

For this prototype gauge, the errors observed in measured increment heights and densities are caused by: 1) sample rotation, 2) hysteresis of the recording system, 3) width of the slit, and 4) the statistical uncertainty of the nuclear counting. Samples could rotate, particularly while moving down, because they are moved thru the gamma ray beam by being pushed by the rotating end of a threaded rod screwed thru a fixed nut. Variations near the upper sides of

interfaces are caused by sample rotation because of uneven amounts of "upstand" in loading. Upstand is defined as the small quantity of expl extruded or trapped in the clearance between the punch and the cup which is left extending above the face produced by the flat end of the punch

To eliminate the deficiencies of the above gauge, an improved density scanner for routine measurements was designed at PicArns as follows:

- 1) A depleted uranium instead of lead collimator was used to increase signal-to-background ratio due to its higher density (19.0 vs 11.3)
- 2) Slit is adjustable for both width and thickness to optimize dimensions for each type of detonator. A narrower slit improves length resolution, but decreases counting rates and reduces accuracy of density measurements
- 3) Slit is vertical to prevent sagging due to its weight
- 4) Sample insertion and removal is facilitated by permitting horizontal movement
- 5) A line source (foil or wire) is provided to make use of a larger fraction of the available flux
- 6) By preventing sample rotation, accuracy of height measurements is improved when interfaces are not horizontal
- 7) Scans are made in opposite directions and averaged to compensate for hysteresis in the recording system
- 8) Because of the wide range of densities of interest, an additional isotope source was needed

to improve accuracy. For RDX and Tetryl, a lower intensity source such as ^{57}Co , which produces 0.014MeV and 0.122MeV gamma rays and has a half-life of 270 days, was selected

A diagram of the improved scanner is shown in Fig 8

Measurement of Homogeneity of Electrical Ignition Element Composition Mix Using a Gamma Ray Densitometer (Refs 17 & 18)

Chemical inhomogeneity was suspected as being a potential cause of misfires in electrical ignition elements used in large caliber ammo. A simple, inexpensive, nondestructive test technique was desired capable of ascertaining the compn of this mix in the assembled elements. The ignition mix is composed of four ingredients: KClO_3 40, PbSCN 32, C 1 and Egyptian lacquer 10%. A sketch of the ignition element is shown in Fig 9

To meet the requirements for inspection, a γ -ray transmission gauge was designed to measure the relative density of the ignition mix in each element (Fig 10). The gauge utilizes an ^{241}Am source emitting 0.060MeV γ -rays. A scanning window 0.250" x 0.050" was machined into the lead shielding to allow passage of the γ -ray beam into the area of the ignition element to be measured. Radiation not absorbed by the ignition mix is absorbed by the scintillation detector. The resultant signal from a 10-sec count is processed by the electronics and displayed on the scaler. From the testing of several hundred randomly selected samples loaded at an Army Ammunition Plant, it was determined that this densitometer provided the desired non-destructive test for measuring relative mix

density. In addition, it also performed the height of fill (cavitation depth) measurement in the same inspection operation

Detection of Base Separation in Artillery Shell by Gamma-Ray Transmission (Ref 15)

This reference discusses the feasibility of γ -ray transmission to inspect for base separation between the steel and the high expl casting in 175mm projectiles. The method consists of passing the section of the projectile containing the metal base-expl interface across a highly collimated beam of ^{60}Co γ -rays and measuring changes in transmission with a scintillation detector

A sketch of the gamma-ray gauge assembly with a projectile in place is shown in Fig 11. The gauge assembly is mounted on a specially designed table to support the weight of the necessary lead and concrete shielding. The adjustable elevator platform which supports the 175mm round at the center of the gauge is operated by a mechanical gear and screw arrangement. This allows the shell to be raised or lowered thru the gamma beam in small controlled increments. A micrometer dial affixed to the table measures the relative shell height position to the nearest thousandth of an inch. A large lead block positioned at one side of the "elevator" contains a hole in the top into which the radioactive cobalt-60 (^{60}Co) source can be placed. A micrometer screw is mounted on a movable 1/2"-wide lead block insert which enables the operator to open this lead block slit in one-thousandth of an inch increments for the cobalt-60 radiation beam to pass. On the opposite side of the shell, a similar large lead block is

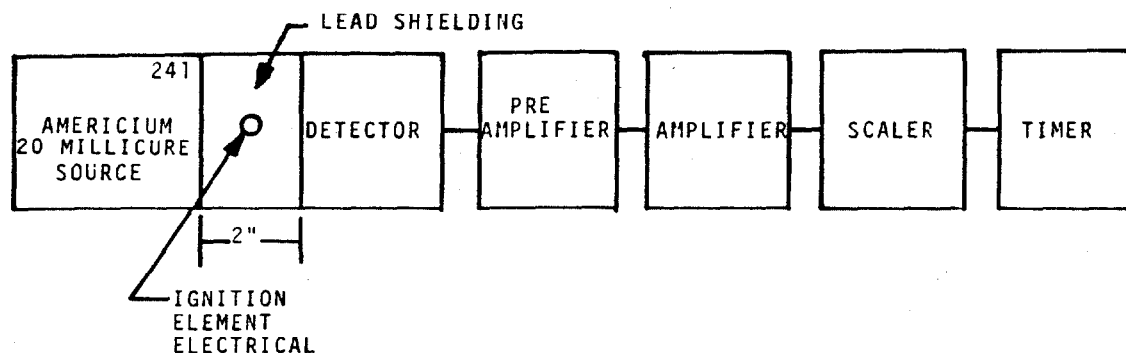
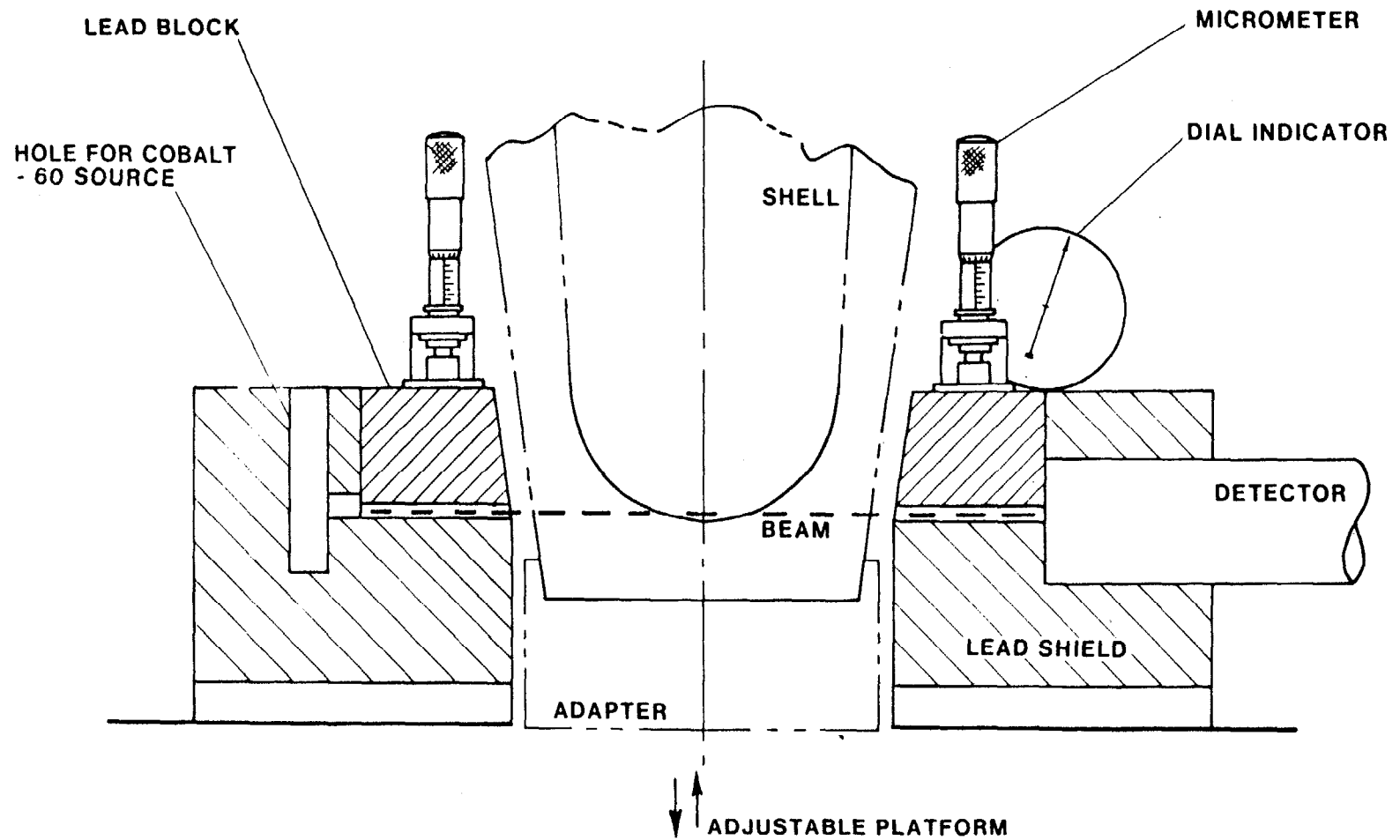

Fig 10 Block Diagram of γ -Ray Measuring Equipment



R 94

Fig 11 Sketch of γ -Ray Transmission Gauge for Base Separation Detector

mounted, with a hole machined into one end to house the detector. A similar micrometer screw and movable 3/4"-wide lead block slit arrangement allows the detector slit to also be operated in thousandths of an inch increments. The bases of the two slits are optically aligned so that the beam of radiation can pass thru to the detector

A 45-millicurie ^{60}Co source, stainless steel encapsulated, is bolted onto an adjustable plastic jig (not shown) for insertion into the "source hole" in the lead block. This allows the source to be precisely positioned in the slit for max radiation transmission. With the source in position an additional shield consisting of a combination of lead bricks and concrete blocks is placed around and under the assembly on the table to maintain a permissible level of radiation for the operator

The shell position indicator is placed so that the dial reading approximates 500 mils when the steel-expl interface is in the beam. Readings can then be taken up to 1/2" above and below this point. Expts showed that relative readings of 500 ± 150 mils were sufficient to obtain data

Conventional Nuclear Instrument Module (NIM) counting equipment is used to process the gamma-ray signal from the scintillation detector. This includes a preamplifier, linear amplifier, single-channel analyzer and a combination timer and digital scaler. Approx 900 volts used to bias the multiplier phototube of the detector are provided by a 3000-V power supply. The single-channel analyzer is set so that only signals above the 1.17MeV ^{60}Co energy peak are counted. This eliminates all low energy scatter from Compton γ -rays and lead X-rays. The shell is moved in increments of a few thousandths of an inch and a series of timed counts are taken at each position

With the above equipment, it was demonstrated exptly that a 30-mil (0.030") gap can be detected using rigidly controlled lab conditions with a mock projectile and an artificially induced separation. This technique was also tested with 100 fully loaded projectiles. The presence of an actual base separation was not positively identified in this very small sampling of shells. However, two projectiles showed abnormal gamma-ray scan profiles. Upon sectioning, these indicated the presence of anomalies at the base region. The method is concluded to be sufficiently sensitive to detect

base separation in artillery shell but requires further development to be adaptable to high speed production line inspection (see description of AIDECS below)

Explosives Detection by Dual-Energy Computerized Tomography (Ref 21)

Computerized tomography (CT) is the numerical reconstruction of a cross-sectional image of an object from a data set consisting of X-ray or γ -ray projections of that cross-section obtained at differing aspect angles. In medical diagnostic imaging, CT has enjoyed enormous success since its first commercial introduction in 1972, and it is now used routinely to visualize various organs in cross-section. This reference explores the potential of adapting the CT technique for expls detection, namely, to search the interiors of luggage or parcels for regions which have the characteristic properties of expls. Specifically, these properties would be densities, ρ , between 1.15 and 1.85g/cc and atomic numbers, Z , of approx 7. The object is to distinguish the signal from a concealed expl from signals of most commonly encountered materials with low Z values, eg, books, toiletries, plastics, etc, which have densities (ρ) less than 1. Actually, CT measures electron density rather than mass density and it is shown that in order to accomplish this purpose, it is necessary to perform CT at two different effective X-ray or γ -ray energies. A preliminary feasibility exptl study indicated that simulated expls in a test box (cast DNT and an Amm Nitrate, sugar and water mixt) could be readily distinguished from the other items in the box (shaving cream, cologne, book, wood, aluminum, water) by dual-energy CT techniques

Fig 12 is a conceptual sketch of what a CT expls detection system might look like. The objects to be examined are placed on a conveyor belt, 2 to 3 meters long, which passes between an X-ray source on one side and an array of column detectors on the other. The design speed for the conveyor is 30cm/sec. The column detectors are 60cm high with vertical slit collimators focused on the extended-anode X-ray source. Source and detector collimation will vary depending on the distance from the source to the detector, so that the spatial dispersion of the X-ray pencil beams thru the examined object will be the same for all projection angles

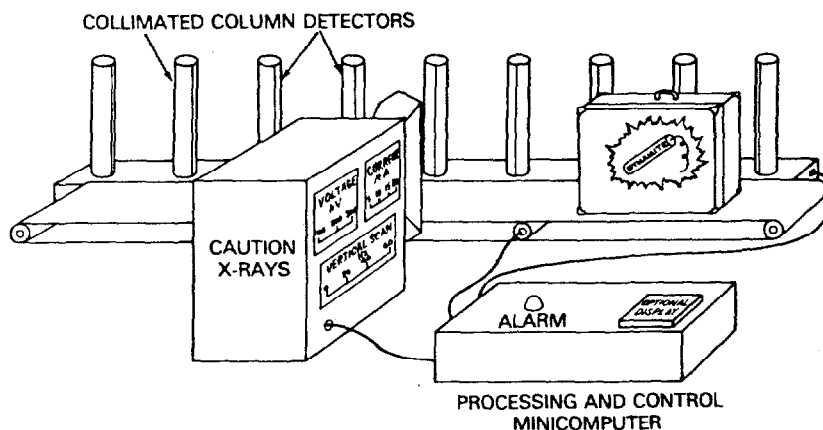

Fig 12 Conceptual Sketch of a CT Explosives Detector

As of this writing, a prototype system for the CT detection of expls in airline baggage was being designed

Measurement of the Quantity of Propellant in 40-mm Cartridge Cases with a γ -Ray Scattering Gauge (Ref 20)

The quantity of propellant in 40-mm cartridge cases must be controlled to ensure reliable weapon operation. The optimum time to measure the propellant quantity on the cartridge production line is after the propellant chamber is sealed. Conventional techniques, such as weighing or absorption radiography, are inadequate because metal tolerances mask the variations in propellant quantity

This report describes the construction and operation of an automated gauge designed to measure the quantity of propellant powder sealed within 40-mm cartridges at a production rate of one per second. The measurement technique employs the back-scattering of low energy gammas from ^{241}Am , a scintillation detector and digital electronics to process the radiation signal

The sensor consists of a tungsten probe, containing a collimated annular Americium source and a collimated detector, which is inserted into each cartridge case for a $\frac{1}{2}$ -sec measurement time. The americium source fits around the propellant chamber while the scintillation detector views the chamber from above. The collimation is designed to allow the detector to receive gammas scattered by the propellant and prevent detection of direct gamma rays or gamma rays

scattered by the metal case. The pulses from the detector are processed by all digital data processing electronics to produce a "go" or "no-go" signal. A mechanical system routes the cartridge from the assembly line into a rotating carousel, inserts the probe and sorts the cartridge either back onto the assembly line or into a reject tray, depending on the signal from the electronics, at a rate of one per second

The accept/reject decision level is set at 80% propellant fill, but due to the statistical nature of the nuclear signal source, cartridges with more or less than 80% propellant are accepted or rejected on a probability basis. The accept/reject requirements for this gauge are: 1) not more than one cartridge can be accepted out of one million tested at 55% fill, and 2) not more than one cartridge rejected out of 500 tested at 100% fill. A prototype gauge of the above design was tested at the Milan Army Ammunition Plant in Milan, Tennessee, and was shown to sort the cartridges as required

Automatic Inspection Device for Explosive Charge in Shells (AIDECS) (Ref 23)

Cracks or voids in the explosive fill of an artillery shell are hazardous because they have the potential of causing a premature explosion before the shell leaves the gun barrel. Shells are therefore inspected using X-ray film imaging techniques which are both relatively slow and expensive. In 1976, the US Army Armaments Research and Development Command (ARRADCOM) in conjunction with its prime contractor, the IRT

Corporation of San Diego, California, began the development of an automated radiation gauging inspection system for large caliber artillery shell intended to replace the X-ray technique. The system was named *AIDECS* for "Automatic Inspection Device for Explosive Charge in Shell" and is still in the process of test and development as of this writing. The ultimate objective is to produce a system capable of making accept/reject decisions on a production basis at a rate of about 1 minute per shell.

The operation of *AIDECS* is based on the Compton γ -ray scattering effect discussed previously in this article. It was stated that the amount of scattering depends on the material density and that it is possible to detect density changes by measuring the variations in the radiation scattered from different points in an object. In the case of HE-loaded artillery shell, these density changes serve to identify flaws

such as cracks or voids in the HE casting. This method of inspection is nondestructive, does not use film, and its speed depends on how rapidly an object can be scanned, and on the time required for data reduction and interpretation.

In the original engineering model of the *AIDECS* application, the radiation source is a group of 3 to 7 capsules containing ^{60}Co , with a total strength of up to 45,000 curies. Radiation from these sources is made to converge onto a point in space which constitutes the inspection point. This is done with a specially designed source collimator which forms a precisely defined γ -ray beam. Any matter placed at this point will scatter radiation in all directions, and it is this scattered radiation which is measured. Provision must be made to assure that the scattered radiation being measured is that originating only from the inspection point, and not radiation scattered from other points along the

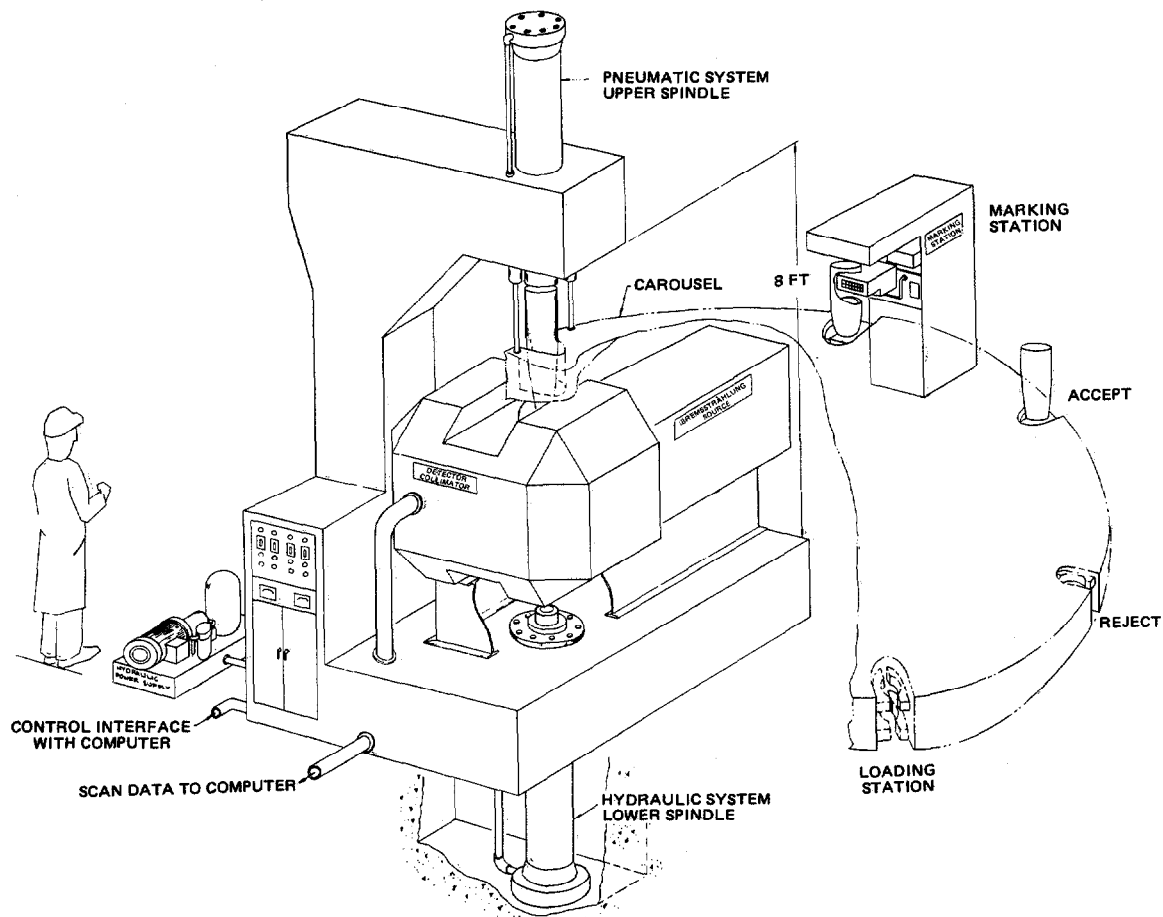

Fig 13 Drawing of Projected *AIDECS* System in Operation at a Loading Plant

path of the beam or from elsewhere. This selectivity is again accomplished with another specially designed collimator

In the first prototype engineering model of AIDECS the nominal inspection point mentioned above actually is an element of volume whose size is 3.18 x 3.18 x 7.62mm (0.13 x 0.13 x 0.30 inch). A shell undergoing inspection is moved so that every element of its total volume passes thru the nominal inspection point. This motion involves a rotation of the shell about its own longitudinal axis, a horizontal translation, and a vertical movement

Radiation scattered from the inspection point, after passing thru the detector collimator, impinges on scintillators which convert this incident radiation to visible light. The visible light, in turn, is sensed by an array of photomultiplier tubes that generate electrical outputs which are directed to computers for data reduction and analysis. These signals are proportional to the density of the HE in the shell

AIDECS utilizes 4 microcomputers in its normal operation. These serve to control all the movement of the shell, to collect and analyze the signals from all inspection points, and to make the accept/reject decisions. Many of these operations occur in parallel since the entire process, involving over 23000 inspection elements in a 105-mm projectile, is designed to be completed in about 1 minute

Fig 13 is a drawing depicting the operating configuration of a projected AIDECS in operation at a loading plant

In its ultimate form, AIDECS is intended to be an inspection device which will provide a high resolution, three-dimensional scan profile of an entire expl charge in an artillery shell. It is designed to perform a differential measurement which, with an appropriately small inspection volume element, will not only identify the presence of discontinuities in the expl (such as voids, cracks, annular rings, base separations and inclusions), but is also to provide data about their size, three-dimensional location and orientation

High Speed Automated Detection of Letter Bombs (Ref 22)

In response to the threat of letter bombs, perpetrated by international terrorists during

the early 1970's, an automated high speed letter bomb detector was developed, produced and tested under sponsorship of the US Postal Service and the Internal Revenue Service. The system is based on the use of γ -rays at two energy levels and of thermal neutrons which in combination allow for the differentiation of expls from paper in letter bombs

Two major characteristic differences between paper and expls are apparent from the compn data listed in Table 7: 1) expls contain smaller concns of hydrogen than paper, and 2) expls contain nitrogen, whereas paper does not. Differences in hydrogen content are detd by using the thermal-neutron beam transmission gauging technique. This method makes use of the very large scattering cross-section of hydrogen for thermal neutrons which is about 30cm^{-1} , depending on the state of chemical bonding. By contrast, carbon and oxygen have neutron scattering cross-sections which are lower by approx a factor of ten (Table 6). Thus, neutron attenuation for a thermal neutron beam transmitted thru a carbohydrate sample, such as paper or cardboard, is detd primarily by the amount of hydrogen present

Differences in weight are measured with γ -transmission gauging. If a γ -ray energy in a sufficiently low range is selected, the interaction mode between the γ -rays and the elemental constituents of explosives and paper listed in Table 7 is essentially limited to Compton scattering, which means that the γ -rays only interact with the target electrons and thus measure target density

Using basic exponential radiation attenuation concepts, this reference shows the development of the expression for determining the hydrogen concn in a piece of mail:

$$\frac{\rho_H}{\rho} = \text{constant} \frac{\ln(I_0/I)_{\text{neutron}}}{\ln(I_0/I)_{\gamma}} \quad (4)$$

where: I_0 = incident beam intensity
 I = transmitted intensity
 ρ = density of material
 ρ_H = density of hydrogen

Thus, it is essential to correct each piece of mail for bulk density in order to obtain a true signal for hydrogen density. For the particular case of relatively thin letters, eq (4) is an over-simplification and has to be modified by using two

Table 7
Comparison of Composition of Cellulose (C₆H₁₀O₅) with
that of Bond Paper and Some Common Explosives

Element	(Percent by Weight)					
	Cellulose	Bond Paper	TNT	RDX	TETRYL	PETN
Hydrogen	6.2	6.2 to 5.8	2.2	2.7	1.7	2.5
Carbon	44.4	44.2 to 41.3	37.0	16.2	29.2	18.9
Nitrogen	0.0	0.0	18.5	37.8	24.4	17.7
Oxygen	49.4	49.2 to 45.9	42.2	43.2	44.5	60.7
Metals and Rare Earths	0.0	0.5 to 7.0	0.0	0.0	0.0	0.0

different γ -rays of low energy in order to obtain an adequate correction for bulk density

The nuclear gauging system to detect for expls in letters sent by mail thus consists of three transmission gauges with appropriate signal acquisition electronics. The bulk density is detd with a dual energy γ -gauge and the hydrogen content with a thermal neutron gauge. ²⁴¹Am (0.060MeV energy) and ¹⁰⁹Cd (0.024MeV energy) are the sources used for the γ -gauge. Separate detectors are employed for each energy range. The neutron gauge has a ²⁵²Cf source embedded in a moderator with a beam aperture and a tritium-filled gas proportional counter as a neutron detector. Data from the three sensors are analyzed to determine hydrogen concn and also the ratio of high-Z vs low-Z elements. The two detectors for the dual energy γ -gauge are placed side by side in close proximity. They view the mail thru a first opening in the transport belt system, while the neutron sensor is placed "downstream" at a second opening. All three detectors scan the identical 3" high segment of each passing letter. The system is designed to determine the presence of expls in less than 100 milliseconds in letter mail. The first prototype tested maintained a false reject rate of 2 in 1000 while simultaneously detecting simulated letter bombs with close to 100% accuracy

Measurement of Low Concentrations of Moisture by Fast Neutron Gauging (Refs 7 & 13)

These papers describe the determination of moisture content in the 0-1 wt % range in bulk

samples of homogeneous energetic materials using fast neutron moderation. The major components of the gauge include a radioisotopic fast neutron source, a sample cell thru which the fast neutrons are directed, an efficient thermal neutron detector assembly, a neutron shield to surround the detector, and associated electronics to count the number or measure the intensity of pulses from the detector

A top cross-sectional sketch of the fast neutron gauge is shown in Fig 14. The sample is sandwiched between the neutron source capsule and the window of a shielded thermal neutron detector. The actual assembly includes either a 5 curie plutonium-beryllium capsule or a 4 microgram ²⁵²Cf capsule as the source of fast neutrons; the neutron output for each source is about 10⁷ neutrons/sec. The sample container

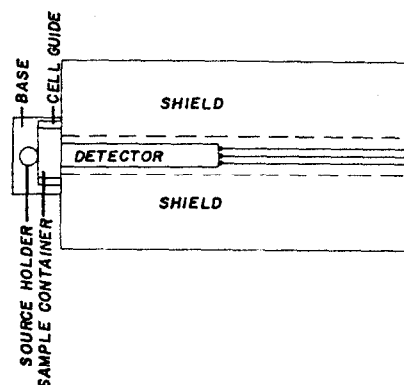

Fig 14 Top Cross-Section Sketch of Fast Neutron Gauging

is a rectangular 500cc aluminum cell. The borated polyethylene shield for the neutron detector contains a 3" diam longitudinal hole, lined with 1/16" thick cadmium. The front of the shield is also lined with cadmium with an appropriate window so that the detector "sees" essentially only those neutrons emanating from the sample. For this work, a lithium iodide scintillation detector was found to be the most efficient for measuring the thermal neutron signal

The determination of moisture by neutron techniques is of particular interest in compds and materials containing inherent hydrogen. Here it might be expected that sensitivity for moisture detection would be greatly decreased as compared to non-hydrogenous materials since in this type of measurement fast neutrons will not distinguish between hydrogen atoms bound as water from those bound in other molecules. However, the hydrogen density of water is generally greater than for most other hydrogenous molecules. Therefore, as long as one uses a

water-free hydrogenous material as a reference blank, the possibility of obtaining an increased thermal neutron response with increasing moisture content should theoretically exist

Using this fast neutron moderation technique, relative count rates vs % H_2O are shown in Fig 15 for four different powdered solids with sand included as a basis for comparison. The lowest exptl point on each curve represents the lowest "water content" at which an increase in count rate of at least 500 counts/min was obtained over the completely dry solid

For sand, K nitrate and BlkPdr, the lowest measurable moisture concn is 0.2 wt %. These three solids are hydrogen-free materials. Dry Amm nitrate, on the other hand, contains 5 wt % of inherent hydrogen. The fractional increase in hydrogen density with increasing amounts of moisture is therefore smaller than for the non-hydrogen containing solids, and this is borne out by the exptl data. Nevertheless, it is still possible to measure 0.3 wt % moisture in Amm nitrate by fast neutron gauging

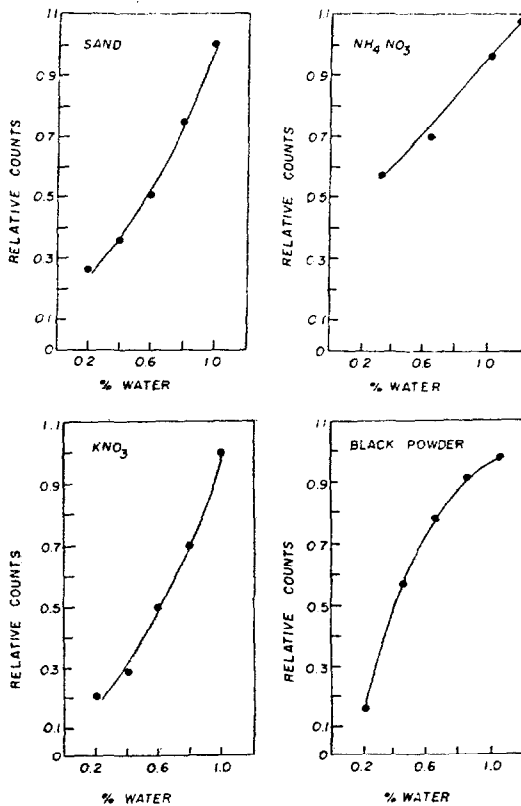

Fig 15 Relative Counts as a Function of Moisture Content for Powdered Materials by Fast Neutron Gauging

Determination of Charge Weight in Sealed Ammunition Items (Refs 13 & 16)

The high speed automatic inspection for the proper weight of expl and proplt charge can be a critical requirement in the munitions field. Gamma-ray gauging can be used for some items, but for many units the tolerances on metal case wall thickness will mask any γ -ray attenuation due to the hydrogenous charge. For such applications, neutron gauging is attractive because it is almost completely insensitive to small changes in metal wall thickness

At PicArsn, ^{252}Cf was evaluated for the "neutron weighing" of charges of energetic materials in small sealed ammo items. The weights of interest are from a few milligrams to about 30 grams per item of powdered hydrogenous material, with bulk density ranging from 0.6 to 1.6g/cc. Using a three microgram ^{252}Cf source, both fast neutron moderation and thermal neutron transmission were compared for charge weight measurement

Fast neutron moderation measurements were made with the gauge described above (Ref 13). A sketch of a thermal neutron transmission gauge is shown in Fig 16. It contains the same basic components as a fast neutron moderation gauge

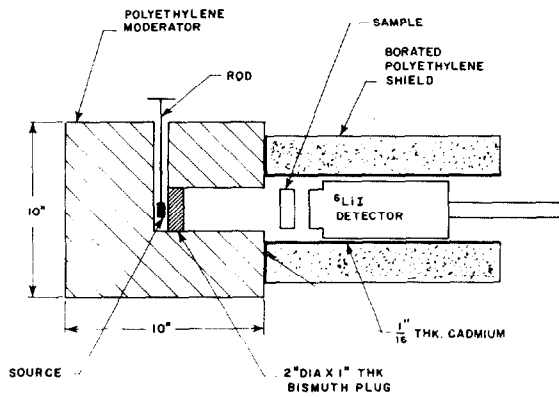

Fig 16 Sketch of Thermal Neutron Transmission Gauge for Measurement of Charge Weight

with the addition of a cylindrical polyethylene moderator to surround the radioisotopic neutron capsule for the production of thermal neutrons. The moderator contains a 2" diam by 5" long "beam hole", and a 1" thick bismuth plug serves to shield the primary fission gammas and to scatter some of the fast neutrons out of the beam.

Measurements were made on samples (9cc) of four different powdered materials by comparing the thermal neutron count rate from each to that from an empty sample cell (Table 8)

In fast neutron moderation, the count rate should increase with a hydrogenous sample between source and detector, whereas the reverse is expected for thermal neutron transmission. These measurements show that thermal neutron

transmission is considerably more sensitive as a technique for "neutron weighing" small hydrogenous charges in sealed items, particularly for materials of a lower hydrogen density than water

The variation of neutron count rate with charge weight by thermal neutron transmission is shown in Fig 17 for a brass cylinder (5cm long x 1.3cm diam x 0.8mm thick wall) with RDX as the charge (fill capacity, 10g). Each point represents a 10-sec count. Non-linearity of response at the top and bottom of the cylinder is due to

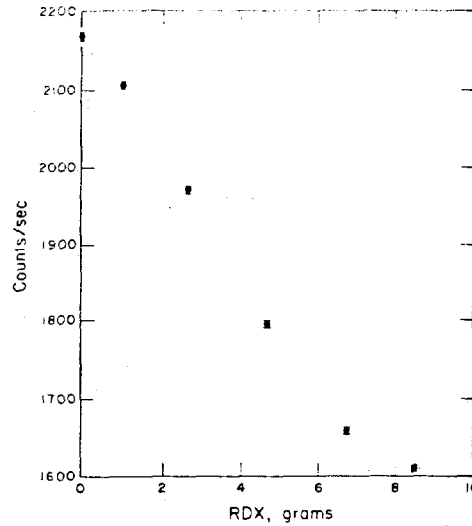

Fig 17 Measurement of Charge Weight of RDX in a Brass Cylinder by Thermal Neutron Gauging

Table 8
Fast Neutron Moderation and Thermal Neutron Transmission for Charge Weight Measurement

Charge ^a	Hydrogen Content, %	Bulk Density	Hydrogen Density	Increase in Count Rate by Fast Neutron Moderation, %	Decrease in Count Rate by Thermal Neutron Transmission, %
H ₂ O	11.1	1.000	0.111	18.8	33.8
RDX	2.7	1.144	0.031	4.3	27.1
TNT	2.2	0.878	0.019	2.5	18.2
M-9 Propellant	2.2	0.667	0.015	1.2	17.8

a - Each charge occupied a 9.0cc volume in the brass cylinder

"edge" effects since the active diameter of the lithium iodide detector is 3.8cm against the 5cm column height in the cylinder

Gauge response as a function of propellant weight is shown in Fig 18 for a 30-mm brass cartridge case (9.8cm long x 3.8cm diam x 0.8mm thick wall). Total propellant fill weight is approx 30g at a bulk density of 0.59g/cc. Again because of geometry, the gauge starts to respond when the propellant level reaches the bottom of the detector window. Until that point there is actually a slight increase in count rate due to increased moderation of fast neutrons after which the attenuation process becomes predominant

In another expt with the same cartridge case, a level gauge was simulated by viewing the top of the case with a 1.6mm thick cadmium filter containing a horizontal slit, 3.5cm x 1.3cm. Here the top of the case and the cadmium slit were aligned with the center of the detector window. The case was first filled with propellant grains to just below the bottom of the slit and successive 0.4-g increments of additional propellant were added (Table 9)

The ability to detect weight differences of the order of a fraction of a gram is excellent

In another application, the feasibility of measuring changes in percussion primer component weight in .50-cal primers was investigated using a

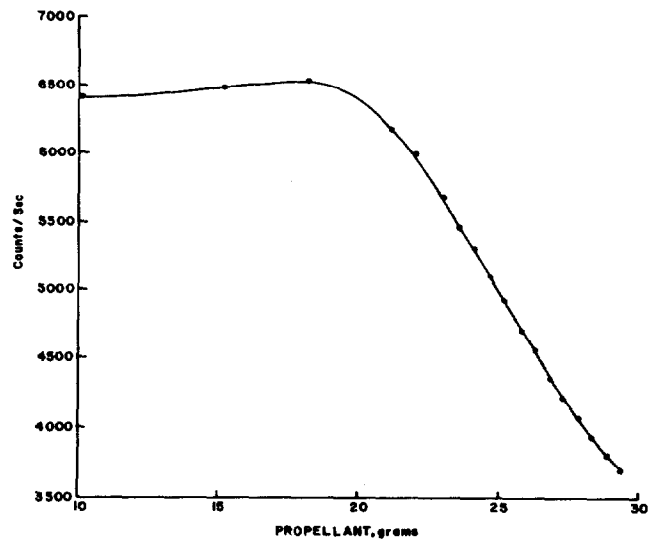

Fig 18 "Neutron Weighing" of Propellant in 30-mm Cartridge Case

1 microgram ^{252}Cf source and a thermal neutron gauge. The data in Fig 19 shows a 1.4 percent change in count rate per grain of primer mix. These results demonstrate that even very small items are amenable for "neutron weighing" applications

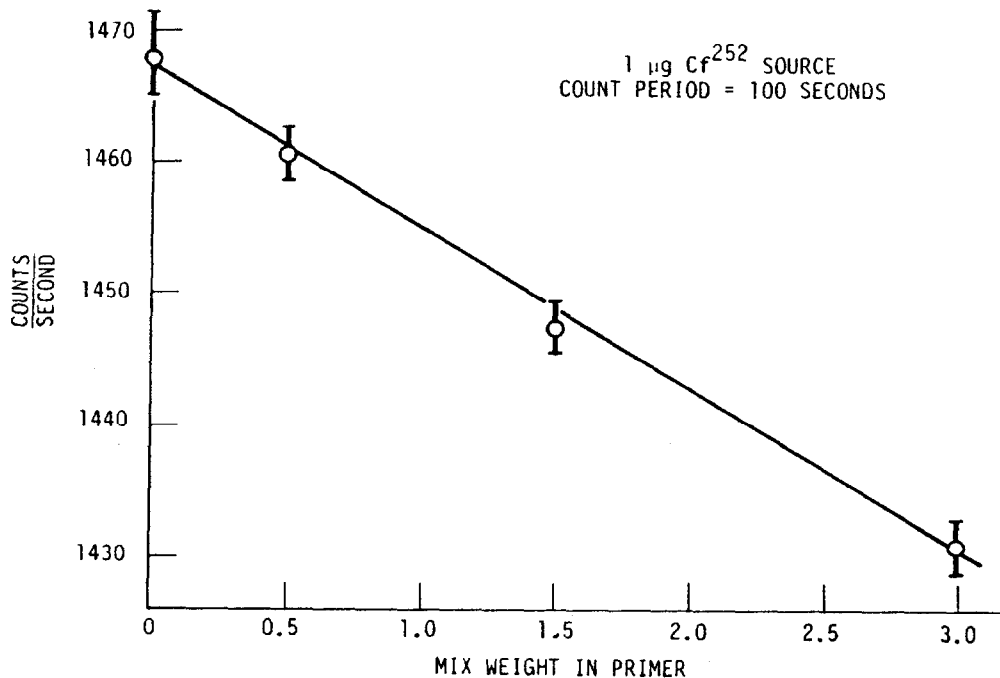

Fig 19 "Neutron Weighing" for Charge Weight in .50-Cal Percussion Primers

Table 9
Propellant Level Gauging with Neutrons

Propellant, Grams	Counts/sec *
26.7	2364±15
27.1	2347±15
27.5	2309±15
27.9	2256±15
28.3	2191±15
28.7	2125±15
28.1	2033±14
29.5	1958±14
29.9	1870±14

*Mean of five 10-sec counts $\pm 1\sigma$

The IRT Corp (Ref 22) demonstrated the feasibility of measuring expl mass per unit length in mild detonating fuze (MDF), ie, RDX in an aluminum sheath. The major advantage of using a thermal neutron gauge for this application is that accuracy is not significantly affected by nonconcentricities of the expl or variations in the thickness of the aluminum sheath

Written by **S. HELF**

Refs: 1) R.E. Monks, "Burning Rate Measurement by Radiographic Examination of Operating Hybrid Motors", NAVWEPS Report **8359** (NOTS TP **3252**), US Naval Ordnance Test Station, China Lake, Cal (1963) 2) J.R. Osborn & R.J. Burdick, "Continuous Measurement of the Burning Rates of Solid Rocket Propellants", Report No **I-64-3**, JPC 369, Jet Propulsion Center, Purdue University (1964) 3) W.A. Anson & J.M. Dewey, "Density Measurements in the Blast Wave from a Surface Burst 500-ton TNT Hemispherical Charge", Suffield Technical Paper No **305**, Suffield Experimental Station, Ralston, Alberta, Defense Research Board of Canada (1965) 4) J.R. Osborn, R.J. Burick & P.Y. Ho, "Techniques for the Continuous Measurement of Solid Propellant Burning Rates", Report No **F-66-3**, JPC 421, Jet Propulsion Center, Purdue University (1966) 5) R.P. Gardner & R.L. Ely, Jr, "Radioisotope Measurement Applications in Engineering", Reinhold, NY (1967) 6) J.R. Webster, "Nucleonic Cryogenic Propellant Gaging System", Final Technical Report **AFRPL-TR-69-145**, General Nucleonics Division, Tyco Laboratories (1969)

7) S. Semel & S. Helf, "Measurement of Low Concentrations of Moisture by Fast Neutron Moderation", *IntJApplRadiation&Isotopes* **20** (1969), 229 8) Anon, "Radiological Health Handbook", US Dept of Health, Education & Welfare (1970) 9) J.F. Ross, "A System and Procedures for Measuring Blast Wave Density in a 500-Ton TNT Surface Burst", Suffield Technical Note No **258**, Defense Research Establishment, Suffield, Ralston, Alberta, Canada (1971) 10) W.E. Voreck & J.W. McCahill, "Scanning Gamma Ray Densitometer System for Detonators", *PATR* **4239** (1971) 11) W.J. Fenrick & B.R. Campbell, "Canadian Blast Wave Density-Time Measurements on Event Dial Pack", Suffield Memorandum No **89/71**, Defense Research Establishment, Suffield, Ralston, Alberta, Canada (1972) 12) Unpublished data by I. Malish & D. Stein, ARRADCOM, Dover, NJ (1972) 13) S. Helf, "Neutron Gauging Using a Small ²⁵²Cf Source", Proceedings of the American Nuclear Society National Topical Meeting on Applications of Californium-252, CONF **720902**, (1972) (available from NTIS) 14) A. Sy Song & G. Durvaldo, *IntJApplRadiation&Isotopes* **26** (1975), 313 15) J. McCahill et al, "Detection of Base Separation in 175-mm Artillery Shell by Gamma-Ray Transmission", *PATR* **4852** (1975) 16) Anon, "Californium-252 Progress", No **19**, p 46 (Published by USDOE, PO Box A, Aiken, SC 29801 (1975) 17) L.G. Derrico, "Measurement of Electrical Ignition Element Composition Mix Using a Gamma Ray Densitometer", *PATR* **4887** (1976) 18) Ibid, "Technical Evaluation—Ignition Element Electrical Lot PSI-3-6", *PATR* **5007** (1976) 19) Anon, "Smoke Detectors", Consumer Reports (Oct 1976) 20) D.W. Blincow et al, "Automated M-9 Propellant Quantity Gage", Rpt **TR-0211**, General Nucleonics Division/Tyco, Pomona, Calif (1976) 21) F.L. Roder, "Preliminary Feasibility Investigation—Explosives Detection by Dual-Energy Computerized Tomography", The Aerospace Corporation, Washington, DC (1978) 22) H. Weber, "Application of Nuclear Gauging Techniques to the High Speed Automatic Detection of Letter Bombs", IRT Rpt **4617-007**, IRT Corp, PO Box 80817, San Diego, Calif (1978) 23) H. Weber et al, "Automated Inspection Device for Explosive Charge in Shells—AIDECS", IRT Rpt **8155-033**, IRT Corp, PO Box 80817, San Diego, Calif (1979)

RADIOACTIVE TRACERS
(USE IN ENERGETIC MATERIALS)

Radioactive isotopes have been used as elemental or molecular tracers in energetic materials and ammo technology from the time they became readily available as by-product materials from the US nuclear energy program. This section reviews 15 such practical applications since the early 1950's. The subject matter is presented in the form of either abstracts or summaries of individual publications and includes applications to proplnts, expls, pyrots and misc. The reader is referred to the original ref for more details on a particular application

Propellant Motion Studies in a 37mm Gun
(Ref 1)

The motion of a proplnt grain along a 37mm gun barrel was followed by tagging or "activating" a particular grain with a radioactive source and following its position by means of radiation detectors along the outside of the barrel. In order that the motion and burning characteristics of the activated proplnt grain not be altered appreciably by the introduction of the tracer, a very small source of high specific activity was imbedded in the center of a proplnt grain. The source was approx 80 millicuries of tantalum-182 sealed in a stainless steel sheath, overall diam about 0.2 cm, length about 0.8 cm. Tantalum-182 has a half-life of 115 days allowing its use in a number of expts and it emits X-rays of approx 1 MeV for relatively easy penetration of the gun barrel. The sealed source was imbedded in the center of a seven perforated No 5280 proplnt grain. The mass of the radioactive source was about 135mg and that of an average grain about 350mg for a total mass of an "activated grain" of approx 455mg

Two radiation detector stations were used along the gun with each station consisting of two units, one on each side of the barrel. A unit radiation detector was composed of two photomultiplier tubes immersed in a liq scintillator consisting of xylene saturated with terphenyl. The container for the soln was a 10 x 10 x 13cm aluminum-lined brass box fitted with appropriate electrical connections for the signals. These detectors provided the desired high count

rate capability (10^6 counts/sec) and high sensitivity required for these measurements

The motion of the "activated" grain, during the burning period, was studied as a function of primer charge, proplnt charge, and the initial position of the "activated grain" in the total proplnt charge. It was found that the initial position of the "activated" grain in the charge was the most important factor affecting its motion. The "activated" grain did not move very much (2.5cm or less) until after peak pressure was reached when the grain was placed near the breech end in the proplnt charge. When the "activated" grain was placed near the muzzle end of the charge, it moved approx 15cm before peak pressure was attained. The authors conclude that its motion indicated that a portion of the proplnt did complete its burning outside of the powder chamber, but the amt involved was not as much as is predicted in the "Lagrangian approximation" which assumes that the unburnt proplnt moves with the gas, the distribution of the solid along the bore being the same as the distribution of the gas

Study of Solid Rocket Propellant Mixing (Ref 5)

Reliable methods of applying radioactive tracer techniques to investigate mixing procedures used for castable composite polyurethane proplnts were developed on a pilot-plant scale and production scale. The composite proplnt before casting and curing is a viscous slurry containing finely divided cryst solids, 1 to 150 μ in particle size, consisting of oxidizer and additives, slurried in the liq binder. Knowing that reproducible ballistic performance and curing properties are dependent upon small amts of these additives, careful consideration must be given to ensure that these materials are uniformly dispersed. An organic binder, an iron chelate binder-curing agent, and a burning-rate modifier made of heavy-metal oxides were tagged with radioactive tracers. The miscible org liq, monoiodobenzene, tagged with iodine-131 was used as a binder monomer simulant; the metal chelate curing agent was tagged with iron-59 and the burning rate-modifier was simulated by silver carbonate tagged with silver-111. All of the above isotopes emit gamma radiation and the half-lives are 8.1, 7.6 and 45.1 days, respectively. The iron compd was used at a level of about

0.25 to 0.50 millicuries per 60 to 100 lbs of proplnt. The other tracers were used at about 1 millicurie per 100 lbs

The expts were conducted in stainless steel sigma-blade type mixers with proplnt mixing capacities of 60, 600 and 2000 lbs, respectively. Radioactivity measurements on samples taken from various locations in the batch at different mixing times were performed with a sodium iodide scintillation detector system

The time required to obtain a uniform dispersion of radioactive material gives a relatively good indication of the dispersion characteristics of either the solid or liq constituents. Studies with the radioactive-iodinated materials in the pilot plant established that varying the total solids content from 75 to 80 wt % had little effect on the time required to obtain a uniform dispersion of the fuel. In comparing 2 proplnts contg 75 and 78.5 wt % solids, respectively, in the production plant, the latter required at least 10 mins additional mixing over the 20 mins required for the 75 wt % solids compn for binder uniformity. The results of the studies obtained from the tests with the curing agent and the burning rate modifier showed that, regardless of the size of the mixer, the materials were incorporated into the proplnt slurry in 15 to 20 mins

Study of Inert-Carrier Propellant Mixing Process (Ref 9)

In the inert-carrier (or inert-diluent) proplnt mixing process an inert liq such as heptane is used to facilitate the blending of the solid ingredients prior to the loading of rocket motors. During the development of this process at the US Naval Propellant Plant, the problem of determining small amts of inert-carrier liq remaining in large amts of proplnt arose. This information was necessary to find whether the quantities remaining in the proplnt are sufficient to interfere with further processing and performance. Information was also needed on how to remove the inert carrier residues from the proplnt. To obtain this information, a radiochemical method, using carbon-14 tagged heptane, was used to study the inert-carrier mixing of single- and double-based proplnts

In the continuous mixing process all of the ingredients are carried to the mixer by the heptane. After mixing is achieved, the proplnt

flows to the decanter where the carrier heptane forms a second layer on top of the proplnt. The heptane is removed by decantation and the proplnt is vacuum cast into a mod or motor. For this study, as the continuous mixing process could not be duplicated in the laboratory, a batch mixing process was used. Radioactive heptane was mixed with the proplnt ingredients initially, using 1 millicurie of heptane-¹⁴C in 200ml of n-heptane. Proplnt samples were subsequently removed and their radioactivity determined by counting with an end-window GM detector system and comparing these counts with that of a standard containing a known amt of heptane-¹⁴C

Expts were conducted to measure heptane content after decanting, after evapn from proplnt surfaces under atm pressure and upon removal under vacuum. In general, it was found that the best conditions for the removal of heptane are (1) high mixing temp, (2) more than one decantation step, and (3) application of a good vacuum for several minutes on proplnt thickness of 0.4cm or less

Non-Destructive Test Method for Defects in Propellant Rocket Motors (Ref 11)

This ref pertains to a US patent for a non-destructive testing method and app for determining the presence of voids, cracks or discontinuities in solid substances by the use of radioactive gases as a tracer. Although developed specifically for use with large solid proplnt rocket motors, composed mainly of active ingredients such as ammonium perchlorate imbedded in an inert binder, the method is claimed to be applicable to other solids as well

The invention involves the use of *clathrate* crystals having a radioactive gas trapped therein. *Clathrates* are formed when substances such as hydroquinone are crystallized from a melt under very high pressure in the presence of rare gases such as argon, krypton and xenon. The molecules of hydroquinone form a cage to hold atoms of the rare gas. The *clathrates* can be powdered into grains the size of salt or sugar with the trapped gases remaining stable within the structure, leakage being on the order of ppm per day

If the trapped gas is radioactive with a high gamma-ray emission, such as krypton-79, which has a half-life of 34 hrs, the *clathrate* may then

be used to sense the presence of voids or discontinuities in a solid material such as a proplnt. The *clathrate* powder contg the krypton-79 is included in the mixt when fabricating a solid rocket proplnt. The added impurity caused by the *clathrate* has little or no effect on the performance of the proplnt itself. The quantity to be included is dependent on the chemical compn of the proplnt, the *clathrate* material used, the radioactive gas trapped within, and the pressure under which the *clathrate* crystal was fabricated. After the proplnt grain is formulated and fabricated, annealing of the grain at a temp of about 70°C releases negligible quantities of radioactive gas. Subsequent heating of the proplnt to 120°C will cause the *clathrate* molecular cage to break down and release the radioactive krypton. (The temp at which a *clathrate* powder will release its entrapped gas is a function of the cryst and molecular structure of the particular *clathrate* used). In the case of hydroquinone *clathrate*, 25.8 atm of krypton-79 can be trapped in one mole of the *clathrate* and subsequently released by heating. When released, the gas being under great pressure will expand into the voids or discontinuities in the grain. These voids or pockets of krypton-79 can then be sensed by any standard radiation detection instrument such as a scintillation detector, or by exposing a photographic film to the proplnt grain. By scanning

the proplnt grain, both inside and outside, it is possible to determine both the presence or absence of flaws or discontinuities, and by using triangulation techniques to determine the exact radial position of such defects

Radiotracer Propellant Gauge (Ref 13)

Fundamental requirements for any zero-gravity proplnt gauging system are accuracy, fast response, and high reliability under all space environmental conditions. A radiotracer proplnt gauge is described in this ref which meets the above requirements and provides significant advantages with many types of storable gaseous proplnt systems. The gauge is insensitive to proplnt tank shape, materials, and wall thickness, and can be easily installed, removed or transferred from one tank to another

The principle of the gauge is as follows: when the tank is full of proplnt, a small quantity of radioactive gas such as krypton-85 is injected into the ullage space, and the tank is pressurized. As the proplnt is consumed, the ullage space volume increases and the volume concn of the radioactive gas is decreased. This "dilution" of the gas is continuously measured, and the measured count rate, being proportional to the krypton-85 concn, is related to the proplnt remaining by a simple algebraic equation. To insure homogeneity, the gases can be mixed by a

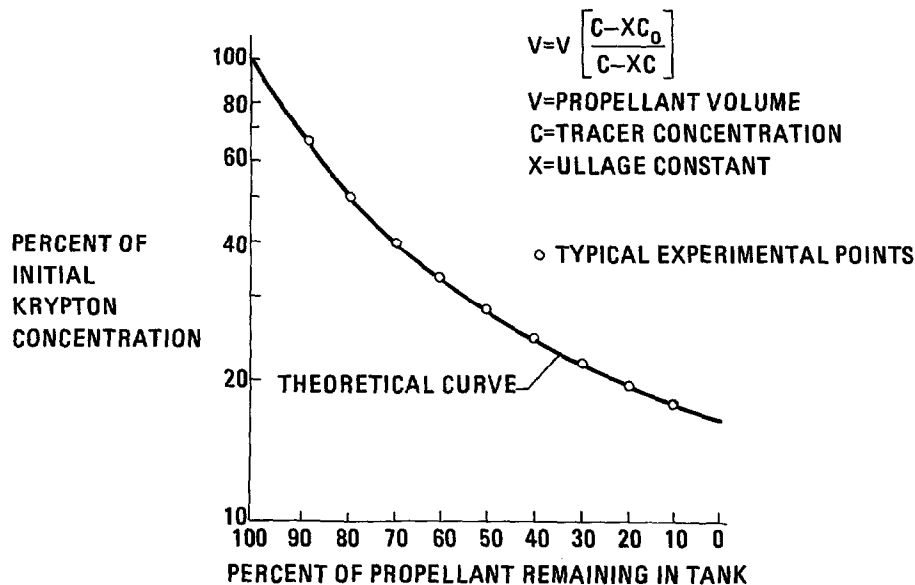

Fig 1 Typical Curve for Normalized Krypton Concentration vs Amount of Propellant in Tank

100 M204A2 hand grenade delay elements were prep'd by hand loading to various column heights (or total charge wts). A correlation was then observed between column height, radiation signal and burning time

These expts demonstrated that with each of the four batches of tagged delay compn, there was no significant change in measured burning time of loaded fuses until at least 20% of the column height (or charge wt) was missing. The count rate, however, decreased essentially linearly with column height. Therefore, in an automatic inspection process, with radioactive delay compn, the pass or fail criteria will depend on a measured difference in count rate of 20%. If we double the inspection safety factor, this pass or fail criterion can be set at a 10% count rate difference. Thus, for an inspection speed of one unit/sec, wherein a fully loaded delay column gives a count rate of 800/sec, a count rate of 720/sec or less will cause rejection

A secondary advantage of this technique is that by virtue of the radioactivity of the mixt, the uniformity of compn can be easily checked before loading by the random counting of a number of aliquots. Thus, loading of fuses need not be undertaken until such uniformity is first established

Monitoring of radiation levels during the manuf of large scale batches of delay powder demonstrated that no safety hazard exists. It should be noted that even if these plant scale batches were doubled to provide 27.2kg quantities, the radiation levels would still be less than the max allowable value

Adsorption from Solution of High Molecular Weight Compounds on the Surfaces of Powdered Explosives (Ref 7)

A radioactive tracer method was developed to quantitatively measure the adsorption of high molecular wt compds on the surfaces of powdered expls. Expts were conducted by allowing a pre-weighed amt of powdered expl to equilibrate with a fixed volume of radioactive adsorbate in an appropriate solvent. The expl must be either insoluble or of very low solubility in the solvent used. At equilibrium, an aliquot of supernatant soln is removed and its radioactivity is measured. The loss in radioactivity is a measure of the amt of adsorbate taken up by the expl. By varying the concn of adsorbate in the soln, an *adsorption isotherm* can be constructed relating amount adsorbed with solution concn

For these expts, adsorbate molecules were tagged with carbon-14 and liquid scintillation counting was used for radioactivity determination. Powdered expls included RDX, HMX and lead azide; high molecular wt compds as adsorbates tagged with carbon-14 included polymethylmethacrylate (PMM), stearyltrimethyl ammonium bromide (STAB), stearic acid and stearyl alcohol. Saturated adsorption was found to occur in most cases as demonstrated by a flattening out of the amt of adsorbed compd with increasing soln concn. The exptl results are summarized in Table 1 indicating the amt of adsorbed compd at saturation and the corresponding equilibrium soln concn at 25°C

The results demonstrate that the surfaces of organic expls, ie, RDX and HMX, are of relative-

Table 1
Adsorption of High M.W. Compounds on Powdered Explosives

<u>Explosive</u>	<u>Adsorbate</u>	<u>Solvent</u>	<u>Amt Adsorbed at Saturation mg/g</u>	<u>Equil Conc mg/ml</u>
RDX	PMM	Toluene	1.0	0.1
HMX	PMM	Toluene	1.0	0.1
HMX	STAB	H ₂ O	0.09	0.2
Lead Azide	Stearic acid	Benzene	14.0	2.0
Lead Azide	Stearic alcohol	Toluene	3.8	3.0
Lead Azide	STAB	H ₂ O	(8 mg/g adsorbed at 1.0 mg/ml concn)	

circulation fan

The gauge has proved equally accurate for constant pressure and blowdown systems, and can also be adapted to vented systems. A typical curve for normalized krypton concn vs the amt of proplnt remaining in the tank is shown in Fig 1. Also shown is the analytical relationship between tracer concn and proplnt remaining in the tank. Statistical error analyses showed the typical average gauging error thruout the entire range of proplnt expulsion to be less than $\pm .3\%$ with a one sigma deviation of less than $\pm .4\%$. This illustrates the consistency and reproducibility of this measurement technique

The major components of the system include a krypton gas injector assembly, a radiation detector assembly, detector electronics and a data processor. The heart of the system is the radiotracer detector assembly which uses semiconductor charged particle detectors to measure the relative concn of tracer gas in the ullage. Krypton-85 is considered the safest radioisotope for such use since there is virtually no bodily retention of this gas

Radioactive Tracers in Cratering Experiments with Comp C-4 (Ref 6)

The Plowshare Program was designed to study the use of nuclear expls for large-scale excavation. An important part of this program was concerned with the investigation of nuclear cratering phenomena. To gain information as to what may occur with nuclear explns, radioactive gold-198 and arsenic-76 were used to study fallout distribution in small-scale cratering expts employing 100g charges of Comp C-4 high expl. The division of the radioactivity between crater and fallout was investigated at varying depths of burial of the charge. The effects of wind and burial depth on the fallout pattern were determined and compared with one existing theory. An attempt was made to note the effect of differences in volatility of arsenic and gold on the fallout pattern

Inspection of Hand Grenade Fuse Delay Element By A Radioactive Tracer Technique (Ref 14)

In the manuf and quality control of M200 series hand grenade fuses, the proper length or total wt of the delay charge element is critical. This paper describes the results of some expts

on the use of radioactive tracers for the inspection of the total delay element in such fuses. The approach is based on the simple assumption that if the delay compn is uniformly radioactive, the intensity of a gamma-ray signal from each delay column would be a direct measure of total charge wt. The objective, of course, was to use the smallest quantity of radioactivity per item necessary for a given inspection rate to minimize radiation hazards

Type I zirconium-nickel alloy delay compn having a formulation 60/14/26 BaCrO₄/KClO₄/70-30 Zr-Ni was used for these expts. Two different radioactive tracers, 27-day chromium-51 and 2.1-year cesium-134, were employed. The first was added to the compn in the form of Ba⁵¹CrO₄ as a fractional percentage of total barium chromate, and the second tracer was included as ¹³⁴CsCl in ppm concn of the total mixt

The amt of radioactive tracer required per fuse for any desired inspection rate and accuracy can be estimated from nuclear counting statistics. An arbitrary inspection rate of one unit per sec was assumed, with the additional requirement that the charge wt be determined to $\pm 5\%$ (std error). This accuracy is more than sufficient to detect one missing increment out of four normally used to fill delay columns

The std deviation obtained in N total counts is $\pm\sqrt{N}$, and % error = $\pm\sqrt{N/N} \times 100 = \pm 100\sqrt{N}$. For a 5% error, $\sqrt{N}=20$ and $N=400$. Therefore, 400 counts are required from each radioactive fuse. In one sec interval, it is assumed that half the time will be required for counting and the other half for decision making (pass or fail). Therefore, the required count rate is 800 counts/sec. Taking into account the number of gamma-rays emitted per disintegration of each radioactive atom, the efficiency of the detector for sensing the gamma-rays, the attenuation factor of the fuse body for the radiation and the self-shielding factor of the delay column itself for the gamma-rays, it was estimated that for an inspection rate of one unit/sec, 0.62 microcuries of chromium-51 and 0.022 microcuries of cesium-134 were required per fuse

Two batches of delay compn were prepd with each tracer, one being a 2000g laboratory run and the other a 13.6kg plant batch to simulate actual production quantities. From each batch,

ly low energy and are thus weakly adsorbing as indicated by the small amts of adsorbates at saturation. Nevertheless, whatever adsorption does occur can be measured quantitatively and with very high sensitivity thru the use of the radiotracer technique. This technique is thus capable of measuring the efficiency of coating agents such as waxes on the surfaces of high expls

Lead azide, on the other hand, has a much greater capacity for adsorbing high molecular wt materials on its surface as evidenced by the greater amts of adsorbates at saturation. Complete saturation on lead azide surface was not achieved in the case of STAB because of the limited solubility of this quaternary ammonium salt in water

Adsorption of Carbon-14-Labeled STAB by HMX (Ref 10)

This paper is a follow-up of the previous study (Ref 7) whereby the adsorption of the carbon-14-labeled quaternary salt, stearyltrimethyl ammonium bromide (STAB), from soln by HMX was investigated in more detail. A solvent system for STAB, consisting of 90% water and 10% ethanol, yielded improved adsorption isotherms on 10-micron size powdered HMX. The data was shown to be quantitative and reproducible with a std deviation of 0.01mg

of STAB per gram of HMX. A typical adsorption isotherm is shown in Fig 2. Included is an isotherm performed on blank 2-dram vials to demonstrate that adsorption of STAB is truly on the HMX crystals rather than the glass. The isotherm for adsorption on HMX is considered to be typical of systems in which a low affinity surface interacts with a high affinity adsorbate. The plateau is considered to represent a saturation of the surface as a complete monolayer of adsorbed STAB molecules, but also including solvent molecules. Additional expts on the reversibility of the adsorption of STAB or HMX by successive dilutions of the equilibrium concn starting at the right end of the plateau and continuing to the left of the knee portion of the isotherm indicated that the reversibility definitely occurred. It was thus concluded that STAB is physically adsorbed onto HMX from the water-ethanol solvent mixt

Analysis of HMX/RDX Mixtures by Isotope Dilution (Ref 3)

A radioactive tracer method is described for the quantitative assay of HMX in mixts of HMX and RDX. The method is an isotope dilution technique in which a known amt of pure HMX, labeled with carbon-14, is added to the mixt, and the radioactivity of a fraction of

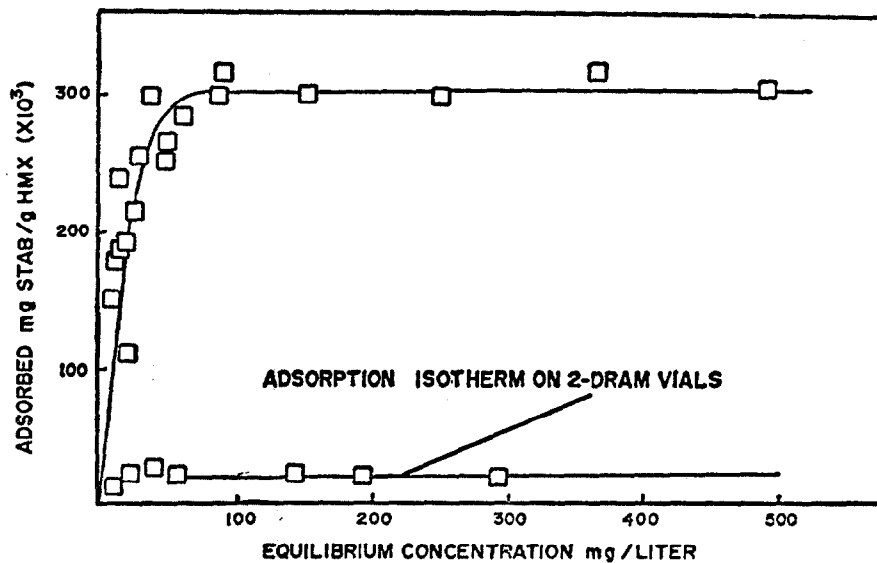

Fig 2 Adsorption Isotherm of Carbon-14 STAB on HMX in 90/10 Water-Ethanol at 30°C

pure HMX isolated from the mixt is determined. The HMX content is calcd from the reduction or dilution of the radioactivity of the isolated sample. This method is considered absolute since the HMX is determined directly and there is no interference from impurities

The isotope dilution technique makes possible the analysis of mixts in which complete separation of the components is very difficult or impossible, since it is only necessary to isolate a small amt (enough for radioassay) of each component in the pure form. The method is based on the principle that the change in initial specific activity (counts per minute per unit wt) of the tracer will be proportional to the amt of inactive form of the same compd in the mixt; that is, the change in counting rate of the original radioactive material is a function of the amt of dilution by the chemically equivalent inactive material

In practice, a known weight y of the pure compd of known specific activity S_o is added to the mixt contg the inactive form of the same compd. The labeled atoms must be firmly bound in the molecule and must not exchange with other components in the mixt. After the mixt is made homogeneous, a pure sample of the compd is isolated and its specific activity S_f is determined. The wt of the compd originally present, x , is then calcd from:

$$x = y (S_o/S_f - 1)$$

If the amt of radioactive material added is small compared to the amt of inactive compd present in the mixt, ie, $y \ll x$, the above formula reduces to:

$$x = y (S_o/S_f)$$

In this latter case, the labeled material must be of very high specific activity

In applying the isotope dilution method to the analysis of HMX/RDX mixts, an accurately weighed amt of carbon-14 labeled HMX of known specific activity (counts per min per g) is added to a known wt of the mixt. The mixt is made homogeneous by dissolving it in acetone. A small amt of pure HMX is then isolated from the mixt by fractional recrystallization from acetone. The specific activity of the pure HMX sample, both before and after dilution, is determined by either dissolving or suspending a known wt in a scintillator soln or gel and counting with a commercial liq scintillation counter.

Some typical isotope dilution assay data on HMX are shown in Table 2

Table 2
Isotope Dilution Analysis of HMX
in HMX/RDX Mixtures

<u>% HMX Added</u>	<u>% HMX Found</u>	<u>% Error</u>
92.5	92.3	-0.2
93.7	93.1	-0.6
95.2	95.7	+0.5
97.6	97.1	-0.6
98.1	98.9	+0.8
Average % Error		±0.5

Use of Radioactivated Metal Discs for Hypervelocity Fragment Erosion Studies (Ref 4)

The use of radioactivated discs of aluminum and steel to estimate fragment erosion in solid targets at very high velocities was found to be feasible. Activation of discs was accomplished by slow neutron irradiation in a nuclear reactor at a flux of 8×10^{12} neutrons per cm^2 per sec for 3 days for the aluminum discs (4g, 2.5cm diam x 0.3cm thick), and for 4 hrs for the steel discs (5g, 2.5cm diam x 0.15cm thick). Gamma-ray spectrometry indicated the presence of ^{59}Fe (half-life 46 days) and ^{51}Cr (half-life 28 days) in ratios 0.5 for aluminum and 1.3 for steel. The radioactivities in the aluminum arose solely from impurities, whereas in the steel they were contributed by the major component, iron, and only supplemented by the chromium impurity. The radioactivity was found by successive acid soln determinations to be distributed evenly in both metals

Exptl firings of the tagged discs with Comp B into polyurethane targets indicated that the mass of unrecovered fragments can be estimated by measuring the total radioactivity of the eroded portion left as a blackened material in the target. Aluminum fragments were found to erode to the extent of 10% and steel 2% at velocities in excess of 6000m/sec. A narrow pipe filled with foamed polyurethane was found to be the best medium for minimizing the dispersion of radioactivity. The ablation of the discs in air was measured by firing them thru a pipe and catching the eroded radioactive material on absorbing material lining the pipe

The Effects of Ultraviolet Light on TNT in Aqueous Solution (Ref 15)

TNT is a chemically resistant molecule which poses a potential pollution problem at expl and ammo production and demilitarization centers. It has been known for some time that a water soln of TNT, upon exposure to sunlight or artificial sources of UV light, undergoes a chemical conversion into products which impart a pink or reddish coloration to the water. This fact suggested that TNT is to some measure vulnerable to the action of UV light and could be degraded by it. This report describes studies to determine the effectiveness of UV light on the decompn of TNT under various conditions

Irradiation of satd aq solns of TNT in open containers for 24 hrs caused a visible change in the appearance of the solns and a drastic drop of TNT concn from 100ppm to 0.16ppm. Samples pulled at intervals indicated that the TNT concn consistently decreased with time. Photochemical conversion products of TNT were evident in samples taken after 3, 6 and 24 hrs of irradiation

Aq solns of 1,3,5 carbon-14 labeled TNT were irradiated in closed vessels for periods of 24, 72, 144 and 312 hrs. The radioactivity of the irradiated TNT, as determined by liq scintillation counting, decreased with increased time of exposure. Labeled CO₂ was found to be one of the photolytic products indicating that ring cleavage occurred. Unidentified volatile products of the reaction were trapped by activated charcoal. Most of the photochemically converted compds remaining in soln were found to be polar and unextractable with benzene or acetone

The data accumulated from the above expts demonstrated that UV light could be very instrumental in effecting a tremendous decrease in TNT concn in aq solns in open systems, and in the elimination of TNT and decompn products completely in closed systems. Originally, this study was designed to develop a pretreatment for aq TNT in order to render the expl more amenable to biodegration. However, the irradiation with UV light proved more effective than anticipated and is considered, by virtue of this investigation, as a complete treatment for aq TNT wastes

Radiometric Determination of Homogeneity of a Multicomponent Pyrotechnic Mixture (Ref 8)

This report describes a quantitative evaluation of the efficiency of blending a multicomponent pyrot compn in a muller-type Lancaster blender by tagging two of the three principal components with radioactive tracers. The pyrot mixt involved was of the following composition:

Barium nitrate	55.00%
Powdered magnesium	40.00%
Laminac	4.95%
Lupersol	0.025%
Nuodex	0.025%

Laminac is a polyester binder for the oxidizer-fuel combination while Lupersol and Nuodex are common accelerators used as setting and drying agents. The mixt can therefore be considered a two-phase system with the oxidizer and fuel ingredients (Barium nitrate/Mg) as the finely divided solid phase and the Laminac plus minor ingredients as the semi-fluid solid phase. The solid phase was tagged with barium-133 labeled barium nitrate; ¹³³Ba is a 0.36MeV γ -emitter with a half-life of 7.2 yrs. Tagging the polymeric phase proved more difficult. Since Nuodex is a mixt of naphthenic acid and its cobalt salts, the use of cobalt-60 (half-life 5.2 yrs, γ -energy 1.17, 133MeV) as a tracer was obvious. After some trial runs, a suitable batch of ⁶⁰Co-labeled Nuodex was prepared as part of the Laminac mixt. 1000g of the tagged pyrot mixt was prepd for the blending expt. Specific radioactivities for ¹³³Ba and ⁶⁰Co were 6.77×10^{-3} microcuries and 0.826 microcuries per g of mix, respectively. The mixt was placed in a muller-type Lancaster blender where the material rests on a rotating pan and the muller wheels, plows and scrapers are stationary. The muller wheels compress and spread the mixt while the plows and scrapers return it to the path of the wheels with each rotation of the pan. Samples of approx 400mg were taken at specific intervals from predetermined sectors of the pan. Each sample was given a sufficient time for the binder to dry prior to pulverizing and weighing two 200mg aliquots. They were then radioassayed with a single-channel gamma-ray spectrometer coupled to a well-type sodium iodide scintillation detector. Each sample was counted for both ¹³³Ba and ⁶⁰Co from the respective energy photopeak

It was found that 10 mins was required for the attainment of a homogeneous mixt and that this blending time could be determined accurately to within $\pm 3\%$. The fact that samples from four different sectors reached homogeneity within the 10-min period demonstrated the efficiency of the blender design. With prolonged mixing, there was an apparent tendency of the Laminac binder compn of the mixt to agglomerate

Radioactive Tracer Method for Detecting the Presence of Firing-Pin Supports in Fuze Assemblies (Ref 2)

A 100% inspection method is described for the detection of the presence of the firing-pin support in the sealed assembly of a post-detonating fuze head. The support cup is a vital part of the fuze head assembly in that it serves as a safety device, preventing the firing pin from coming in contact with the detonators during the normal course of rough handling before the shell on which the fuze is mounted is fired. The method consists of applying a radioactive silver marking to the support cups before assembly of the fuze head components and then detecting the presence of the radioactive cup in the assembled unit by means of a scintillation counter. Radioactive tagging of the cups (which are composed primarily of copper) is accomplished by plating silver-110 (half-life, 270 days) onto the cups by simple chemical displacement from a very dilute soln of silver ions. Approx 0.01 microcuries of ^{110}Ag is deposited on each cup

The method is simple in operation and by observing a few precautionary measures any radiation hazard is avoided. A minimum of specialized equipment is required and the entire process is relatively inexpensive

Recovery of Ammunition Items Using a Radio-tracer Technique (Ref 12)

A recovery technique is described for the location and retrieval of items of ammo being proof-tested in the field. Impetus for this work was prompted by the extreme difficulty often encountered in the recovery of small items during firing tests over rugged or difficult terrain. A reliable and rapid location system is often needed to a) recover or destroy live "duds" to eliminate expl hazards to personnel; b) recover

"duds" to determine reason for failure; c) recover classified components from uncontrolled areas for security reasons; and d) examine impact points for performance information

The basis of the method is to tag each item of ammo with a gamma-emitting radioactive tracer before firing, and then to locate the item with a sensitive radiation detector meter after it is projected. Scandium-46 (84-day half-life) was selected as the most suitable radiotracer for this purpose. The tracer is applied to the item to be tested as a sealed source in the form of a small adhesive tab. Although a specially designed scintillation detector is recommended for retrieval purposes, it was found that commercially available survey meters were also adequate. The method is 100% effective for the recovery of ammo items over a wide variety of terrain and environmental conditions. The overall procedure is simple and requires a minimum of radiation safety control. Data is presented in Table 3, giving max detection distances for the location of tagged items as a function of source strength in millicuries

Table 3
Maximum Detection Distances for Location of Scandium-46 Tagged Ammunition Items

Source Intensity, Millicuries	Detectable Distance, feet	
	Source on Surface	Source Under 3 in of Rocky Soil
0.1	19	7
0.2	29	8
0.3	33	11
0.5	39	15
1.0	54	19
2.0	76	22
3.0	94	23

Note: For additional information on use of radioactive tracers in energetic materials, see also "Nuclear Tracers in Explosives Chemistry" in Vol 8, N210-L to N219-L

Written by S. HELF

Refs: 1) R.H. Comer et al, "Propellant Motion Studies in a 37MM Gun Using a Radioactivated Powder Grain", BRL Memorandum Rpt No 1820 (1954) 2) S. Helf et al, "Development of an Inspection Method Using a Radioactive Tracer for Detecting the Firing Pin Support in PD Fuze

M48A3", PATR 2030 (1954) 3) F.S. Holahan et al, "Analysis of HMX/RDX Mixtures by Isotope Dilution and Spectrophotometric Procedures", PATR 2625 (1959) 4) S. Helf et al, "Use of Radioactivated Metal Discs for Hypervelocity Tracer Studies", PATR FRL-TR-11 (1960) 5) A.M. Hoffman, IEC 52 (1960), 781 6) M. Lindner et al, "Project YO-YO Radiochemical Measurements", UCRL-6998 (1962) 7) C.G. White et al, "The Surface Chemistry of Explosives", PATR 3008 (1962) 8) R.J. Graybush & T.C. Castorina, "Radiometric Determination of Homogeneity of a Multicomponent Pyrotechnic Mixture", PATR 3056 (1963) 9) P. Wilkness and A. Moghissi, "A Radiochemical Method for the Determination of Content and Removal of the Inert Carrier in an Inert Carrier Propellant Mixing Process", NAVWEPS RPT 8569, US Naval Propellant Plant, Indian Head, Md (1964) 10) J. Haberman and T.C. Castorina, AnalChem 36 (1964), 1917 11) M.L. Hanson & C.T. Brown, USP 3299269 (1967) 12) S. Helf & J.W. McCahill, "Recovery of Ammunition Items Using a Radioactive Tracer Technique", PATR 3489 (1967) 13) J.F. Wakeman & B. Burns, Instruments & Control Systems (March 1967), 95 14) S. Semel, M. Gilford & S. Helf, Materials Evaluation (1970), 246 15) C.L. Andrews & J.L. Osmon, "The Effects of Ultraviolet Light on TNT in Aqueous Solutions", Weapons Quality Engineering Center Rpt 75-197 (1975), Naval Weapons Support Center, Crane, Indiana

Radio Proximity or VT (Variable Time)

Fuze. See Vol 4, D918-R to D921-R

Radius of Rupture in Underground Blasts. See Vol 2, B182-R under "Blast Effects in Earth"

Radoubage des Poudres (Fr). Reworking of proplnts. When a proplnt is stored for long periods of time, or when it has been subjected to such adverse conditions as heat, moisture, smoke, etc, it undergoes changes which result in decreased stability, resulting in failure to pass required tests. In order to "rejuvenate" such proplnts the following method may be used: The proplnt grains are subjected to soaking

(*trempage*) for a short time in a cold concd alc soln of a stabilizer such as diphenylamine. Although this operation is similar to one called *lissage*, the purpose is different. While in *lissage* only surface treatment is desired, radoubage requires a deep penetration of the solvent and stabilizer into the grains in order to destroy the products of decompn such as nitric and nitrous acids, nitrogen oxides, etc

If it is desired to improve the progressivity of the proplnt, the radoubage may be combined with *lissage*. For this, a proplnt is subjected to *trempage* in a soln of diphenylamine in aq alc to which some camphor may be added

A short description of radoubage is given in Ref 1. Ref 2 describes the radoubage of deteriorated US proplnts left in France by American troops after the termination of WWII, rendering them suitable for use in the 155mm howitzer

Refs: 1) J. Fauveau & R. Delpy, MP 31, 165-66 (1949) 2) P. Touratier, MP 33, 404-11 (1951)

Rafale (Fr). A WWI expression describing the massed fire of 75mm guns loaded with shrapnel. The Fr 75mm gun, Model 1897, fired a 16-lb shrapnel shell contg 300 lead balls weighing 12g each

Ref: J. Quick, "Dictionary of Weapons and Military Terms", McGraw-Hill, NY (1973), 364

Raibun (Enka). See under Japanese Explosives, Ammunition and Weapons in Vol 7, J46-L

Raikō or Raisansuigin. See under Japanese Explosives, Ammunition and Weapons in Vol 7, J46-R

Railroad or Highway Fusee. A commercial low intensity (70-85 candlepower), slow burning rate (about 2 minutes/inch), red flare used for signaling or warning purposes. A US military version under the designation M72, *Railroad Warning Fusee: red 20 minutes* is about 16" in overall length with spike and cap. During burning, a prodigious molten and dropping-off residue is formed, part of which tends to form a

sintered scoria or chimney. The fusee is ignited by a safety-match-type "button". On top of the wooden plug that is part of the protective cap is a layer of match striker material protected by a water-resistant wrapper (Ref 2 & Ref 3, p 128)

A typical formulation of a good commercial item is given in Ref 3, p 362 as Sr nitrate 74, K perchlorate 6, sulfur 10, grease or wax 2-6, and sawdust or hardwood shavings 8-4%. Closely related formulations have been reported by Weingart (Ref 1)

As a commercial item, mass-produced by at least half a dozen US manufacturers, the fusee is a very inexpensive flare, but within limits, serviceable and well-functioning if protected from exposure to very high humidity for prolonged periods. Beside its use by truckers and brakemen as a warning light, it has military and semi-military applications such as in clandestine operations for the outlining of drop zones or landing strips (Ref 3, p 128)

Refs: 1) G.W. Weingart, "Pyrotechnics", 2nd Ed, Chemical Publishing Co, NY (1947, reprinted 1968) 2) Anon, "Specification for Red Railroad Fusees or Red Highway Fusees", Bureau of Explosives, Association of American Railroads, Edison, NJ (May 1, 1959) 3) Ellern (1968), 128 & 362

Railroad Torpedo. An impact-sensitive pyrotechnic mixt which, when interposed between a steel rail and the advancing action of a railroad engine wheel, will expld with a report loud enough to be heard in the engine cab above other background noises. A typical US formulation contains K chlorate 40, sulfur 16, sand (-60 mesh) 37, binder 5 and neutralizer 2% (Ref 6, p 376). Other formulations are given in Refs 1, 2, 3 & 4. The compn of choice is compressed in pellet form with a flat bottom and rounded top, and is wrapped in moisture-resistant paper. Sand particles glued to the bottom and a pair of Pb or Al straps hold the item firmly onto the rail, since the torpedo must not be dislodged in a severe rain or windstorm

Because these torpedoes are handled rather casually, it is imperative that their impact sensitivity not be excessive. In testing, a 25-lb drop-weight of a certain profile is used, which must not initiate the expl mixt when dropped from a height of 8" but must function (at least on the

second try) from 16". The sound level at a distance of 20' should be no less than 105dB. The torpedo must not disperse any damaging fragments (as evidence by its effect on a denim cloth at 3'), and conditions of water and heat resistance are detailed by commercial convention in Ref 5

Certain foreign railroad torpedoes are actuated by a primer and a BlkPdr charge confined in a metal capsule (Ref 6, p 182)

Refs: 1) F. Dutcher, USP 1421187 & USP 1421188 (1922) & CA 16, 2992 (1922) 2) L.A. Sherman, USP 2061854 (1936) & CA 31, 866 (1937) 3) R.A. Hunter, USP 2189398 (1940) & CA 34, 4272 (1940) 4) E. Azzarello, RevTecFerrovieItal 58, 159-62 (1940) & CA 38, 1367 (1944) 5) Anon, "Specifications for Standard Track Torpedoes", Bureau of Explosives, Association of American Railroads, Edison, NJ (Feb 1, 1949) 6) Ellern (1968), 182 & 376

Railway Mount (Railway Carriage). Mount for railway artillery. No longer in use by US armed forces, but still of interest for possible future application. Railway mounts are classified, according to the method of absorbing recoil energy, as *sliding mounts*, *rolling mounts*, and *platform mounts*. In the first two types there is no recoil system and the energy is absorbed by sliding or rolling with the brakes set. The platform mount is equipped with a recoil system and remains in place without movement

Ref: Anon, OrdTechTerm (1962), 246-R

Rakarok. See under Rack-a-rock in this Vol

Randalite. A mining expl patented in Fr in 1895 by Randale of the USA: Na nitrate 58-76, nitrophenol 34-16, and nitronaphthalene (resin, sulfur or charcoal) 8%

Ref: Daniel (1902), 669

Randanite. A kaolin-like variety of diatomaceous earth found at Randan, Auvergne, Fr. It has been used in lieu of kieselguhr in some Dynamites

Refs: 1) Daniel (1902), 669 2) Marshall 1 (1917), 360

Randites. Expls patented by Rand in Engl in 1892 contg, No 1: K chlorate 80, NB 20%; No 2: K chlorate 42.5, NB 15.0 and Mn dioxide 42.5%; No 3: K chlorate 51, NB 15 and inert material 34%

Refs: 1) Daniel (1902), 669 2) Giua, Trattato 6 (1959), 395

Raney Nickel [Raney Ni, Raney nickel catalyst or Raney's nickel catalyst (Refs 1, 2 & 2a)]. V porous small particles of Ni contg adsorbed H_2 to which is attributed several different structures, Ni_2H (Ref 6) and NiH_2 (Ref 7). Raney Ni particles range in size from 10 to 100Å and have large specific surface areas ($87m^2/g$ for Raney Ni type W-6). All forms of this alloy contain small percentages of Al which have been found to be essential for its catalytic action. For instance, the W-6 form contains 12.7% Al (Ref 4). The mat is a v dense greyish-blk powder or (cubic) cryst. Prepn is by fusing 50p Ni with 50p Al, pulverizing the alloy and dissolving out most of the Al with NaOH soln (Refs 1, 2 & 4). More current methods of prepn are given in Tucker (Ref 3)

The mat is pyrophoric and can be shock-ignited if enclosed in a glass bottle which ruptures on impact. Also, degassing of the catalyst by heat and vacuum releases H_2 which may expld (Ref 5). However H_2 can be safely removed from the catalyst by prolonged aeration of the w slurry. This process also eliminates the pyrophoricity of the alloy (Ref 4a)

Safe handling of Raney Ni requires an inert gas atm (Ref 5). It is usually stored at ambient press and temp under eth, ethanol, dioxane, methylcyclohexane or w (Ref 6)

The porous Ni particle, or skeleton, which is left by the preparative leaching process offers such an excellent adsorbitive surface for H_2 that the alloy is used as an economical means for the hydrogenation of alkenes to alkanes at low press (1 to 4 atm) and moderate temps (0 to 100°). A further use for Raney nickel's adsorbitive surface is in the desulfurization of organic compns in various processes (Ref 7)

For more information on nickel see under this title in Vol 8, N26-L

Refs: 1) M. Raney, USP 1628190 (1927) & CA 21, 2116 (1927) 2) Ibid, USP 1839974 (1928) & CA, not found 2a) Ibid, USP

1915473 (1933) & CA 27, 4361 (1933)
3) S.H. Tucker, JChemEduc 27, 489-93 (1950) & CA 45, 2432 (1951) 4) G. Brauer, Ed, "Handbook of Preparative Inorganic Chemistry", 2, 2nd Edn, Academic Press, NY (1965), 1625-30 4a) Ellern, Pyrotechnics (1968), 31
5) L. Bretherick, "Handbook of Reactive Chemical Hazards", CRC, Cleveland (1975), 134 & 900 6) Merck (1976), 1054, No 7917
7) N.L. Allinger et al, "Organic Chemistry", 2nd Edn, Worth, NY (1976), 289 & 479

Range (rg). 1) The capability of a rocket missile, guided missile, or the like that indicates how far it can fly or be projected; also, the capability of a gun, radar transmitter, etc, that indicates how far it can project a missile or radiate effective waves, or otherwise exert influence at a distance under given conditions; also, the capability of a place measured by the distance to which a missile, radar wave or the like can be projected from it, as in 'the range of a launching site'. 2) The measured or estimated distance between one object and another, especially as applied to the distance between a gun and its target, between a radar set and its object of interest, or between an aircraft and its base. 3) In bombing, the horizontal distance that a bomb travels after release to the moment of impact. 4) The factor of forward distance that a bomb or other missile travels after release, as distinguished from the factor of azimuth, as in 'the bomb is controlled in azimuth but not in range'. 5) An area set up for bombing practice, gunnery practice, or harmonization, as in 'bombing range'. 6) The capability of an aircraft that indicates how far it can fly under operating conditions from the moment of takeoff to the time when its fuel supply is exhausted. 7) To find the range of a target; to adjust a gun to the range of a target

Range Angle. The angle between the aircraft-target line and the vertical line from the aircraft to the ground at the instant a bomb is released. Also called 'dropping angle'

Range Calibration. Adjustment of a radar so that when 'on target' the radar set will indicate the correct range

Range Correction. Changes of firing data necessary to allow for deviations of range due to weather, materiel, or ammo

Range Correction Board. Device with which the correction to be applied to a gun is computed

mechanically. The correction that is obtained allows for all nonstandard conditions, such as variations in weather and ammo, and it is known as the 'ballistic correction'

Range Determination. Process of finding the distance between a gun and a target, usually by firing the gun, by estimating with the eye, by the use of a range finding instrument, or by plotting

Range Deviation. Distance by which a projectile strikes beyond, or short of, the target. It is the distance as measured along the gun-target line or along a line parallel to the gun-target line

Range Difference. The difference between the ranges from any two points to a third point; especially the difference between the ranges of a target from two different guns

Range Firing. A set of exptl firings conducted in order to obtain the data necessary to complete a firing table for a specific combination of gun and ammo. It is distinguished from other firings in that the primary purpose is to determine the positions of the bursts on impact, the times of flight, and their respective dispersion

Range Ladder. A naval term for a method of adjusting gunfire by firing successive volleys, starting with a range which is assuredly over or short and applying small, uniform range corrections to the successive volleys until the target is crossed

Refs: 1) Anon, *OrdTechTerm* (1962), 247
2) Anon, "Dictionary of United States Military Terms for Joint Usage", The Joint Chiefs of Staff, Washington, DC (1964), 118 & 230
3) J. Quick, "Dictionary of Weapons and Military Terms", McGraw-Hill, NY (1973), 366-67

Rankine-Hugoniot (R-H). See under Rankine-Hugoniot and Hugoniot Equations in Vol 4, D278-R to D281-R; Skidmore and Hart Equations of State, D291-R to D293-R; and Rankine-Hugoniot and Hugoniot Relations, D604-L ff

RAP-14. A Fr short-to medium-range unguided spin-stabilized ground-to-ground artillery rocket system. The launcher holds 21 rockets, and they may be fired singly or in salvos of 7, 14 or 21. The individual rockets are of 140mm cal and have a length of 200cm, a wt of 54kg, and a range of 16km. The original design of the

rocket incorporated a fragmentation warhead, but there is now available a new type of warhead which projects a large number of metal balls, and which is considered to be more effective than the fragmentation type. Incendiary, smoke, and illuminating heads can also be fitted

Refs: 1) J. Quick, "Dictionary of Weapons and Military Terms", McGraw-Hill, NY (1973), 367
2) R.T. Pretty, Ed, "Jane's Weapon Systems-1977", 8th Ed, Franklin Watts, NY (1976), 405-06

Rapier. A UK battlefield anti-aircraft missile system intended to provide low-altitude defense in both ground and seaborne roles. The system consists of a detection radar which spots incoming aircraft, an IFF device which discriminates between friendly and hostile aircraft, an optical tracker, and a housing for four missiles which are automatically aligned on the target. After an alert, the operator sees the target and follows it by manual tracking; when the target comes within range, the computer alerts the operator and he can then fire the missile. Deviations between the missile path (which carries rear flares) and the target is measured by the computer, which then relays commands to the missile in order to keep it on a collision course. The system, including the generator, is fitted into three small units which can be towed by a jeep-sized vehicle, the whole being air-droppable. Rapier is ineffective against supersonic aircraft, it can be operated by a single individual, and it can be mounted in armored personnel carriers
Refs: 1) E. Luttwak, "A Dictionary of Modern War", Harper & Row, NY (1971), 162
2) J. Quick, "Dictionary of Weapons and Military Terms", McGraw Hill, NY (1973), 367
3) R.T. Pretty, Ed, "Jane's Weapon Systems-1977", 8th Ed, Franklin Watts, NY (1976), 81-82

Rarefaction Effect. See under Blast Effects in Air in Vol 2, B180-R

Rarefaction (or Expansion) Wave. See in Vol 4, D500-R to D502-L

Raschig Weisspulver and Raschit. Types of inexpensive blasting expls patented by F. Raschig in 1911. One of the formulations consisted of Na nitrate 62 and "Zellpech" 32%; another of K nitrate 70 and Zellpech 30% (Zellpech is a pitch obtained by evapg the liquor from the sulfite cellulose industry) (Refs 1, 2, 3 & 5)

According to Davis (Ref 4), "Raschig's White Blasting Powder" was prepd by dissolving 65p of Na nitrate and 35p of Na cresolsulfonate together in w, running the soln in a thin stream onto a rotating, heated steel drum, whereby the w was evapd. The resulting crust was scraped off in the form of flakes, which were packed in w-proof paper cartridges

Refs: 1) F. Raschig, *AngChem* **25**, 1194-97 (1912) 2) *Ibid*, **SS 7**, 292 (1912)
3) Naoum, *Expls* (1927), 16 4) Davis (1943), 50 5) *PATR* **2510** (1958), Ger 155-56

RATO (Rocket Assisted Takeoff). 1) A takeoff assist by an auxiliary rocket unit or units. 2) The auxiliary rocket unit or group of units used in such a takeoff. **RATO** is preferred to **JATO** (jet assisted takeoff) (see Vol 7, J67) when applied to a takeoff assisted by a **RATO** unit
Refs: 1) Anon, *OrdTechTerm* (1962), 248-R 2) J. Quick, "Dictionary of Weapons and Military Terms", McGraw-Hill, NY (1973), 367

Rauchlose Pulver. A smokeless powd compn adopted by the Austr Imperial Govt in 1893. It was similar to the Brit Cordite of that era (see Vol 3, C532-L)
Ref: Thorpe **4** (1949), 518

Rave Explosive. An expl mixt, patented in Engl in 1859, was prepd by passing a current of chlorine (in excess) into an aq paste contg 20p of K carbonate, 30p of shredded straw, and 15p of powdered anthracite. Also see Vol 2, C206-L under Chlorate Explosives
Ref: Daniel (1902), 669

Rayon. A semisynthetic fiber existing in two coml forms. The first form is comprised of regenerated cellulose as well as mfd fibers consisting of regenerated cellulose in which sub-

stituents have replaced not more than 15% of the hydrogens of the hydroxyl groups. The second form of rayon, called *modified* rayon, is made primarily of regenerated cellulose and contains nonregenerated fiber forming material; viz, a fiber spun from viscose (see below) contg casein or some other protein (Ref 21). For information on cellulose see the article under this title in Vol 2, C95-R to C100-L

Rayon was first made by denitration of cellulose fibers (Chardonnet process). The cellulose was first reacted with a mixt of nitric and sulfuric acids to form NC. The prod was then dissolved in a mixt of eth and ethanol and spun into yarn by a "dry" spinning process. In some instances the yarn was denitrated by alkaline hydrosulfites, neutralized and then w washed and dried (Ref 9). See also under "Cellulose Nitration, Denitration" in Vol 2, C118-R to C119-R

Today rayon is made by either the *viscose* or the *cuprammonium* process. The latter process is based on Schweitzer's discovery in 1857 that it is possible to dissolve cellulose in cuprammonium hydroxide, the soln being due to the formation of a Cu-cellulose complex. The mfg procedure involves processing the cuprammonium soln by filtration and deaeration prior to pumping it thru holes in a spinneret into sl alkaline w which coagulates the Cu-cellulose soln into rayon filaments. The filaments are then stretched to the desired fineness (Ref 11). The viscose process is the most widely used because of its great versatility and low cost operation. In this multi-step mfg process a woodpulp cellulose is first reacted with an excess of NaOH soln to form alkali cellulose. This prod is then shredded to provide an adequate surface area for two sequential chemical reactions. The first is a thorough aging reaction with oxygen, and the second is a thorough xanthation reaction with CS₂. The resulting Na xanthate is then dissolved in dil NaOH to form a prod termed "viscose". The viscose is then prepd for spinning by filtering, deaeration and then ripening. Rayon fibers are subsequently produced by extrusion of the viscose soln thru a spinneret into a spin bath which is usually sulfuric acid, Na sulfite, Zn sulfate and trace quantities of surface-active agents. The coagulated filaments are then completely regenerated to cellulose by continued reaction with the acid of the bath.

The remaining steps of the process include desulfurization, bleaching, washing, application of lubricant, drying and packaging (Refs 6 & 11)

Rayon is one of the most important man-made fibers in prodn; it forms a large portion of the total world prodn of synthetic fibers (Refs 6, 9 & 11). Its mil uses include proplnt powder bag material (Refs 4a & 16), cartridge bag cloth (Refs 2 & 5), spacer and shock isolation inserts in proplnt charges for fixed and semi-fixed ammo (Refs 3 & 4), shock and blast resistant nozzle extension insulation material for rocket motor systems (Ref 19), parachute cloth for pyrots (Ref 1), a heat shield mat when carbonized for missiles (Refs 7, 8, 10, 12, 13, 14, 15, 18 & 20), and a small arms projectile absorbing material in soft body armor (Ref 17)

Refs: 1) H.S. Eroo, "Investigation of Domestic Woven Silk for Pyrotechnic Parachutes", PATR 791 (1937) 2) D.R. Cameron, "Develop a Substitute for Grade E Silk Cartridge Bag Cloth for Semi-Fixed Ammunition", PATR 1093 (1941) 3) R.M. Dennis, "Examination of Unfired 20mm AP Incendiary Complete Round of German Ammunition", PATR 1248 (1943) 4) J.P. Wardlaw, "Examination of Unfired Separate Loading Normal Propelling Charge for 10cm (100mm) K18 Guns, German (FMAM-441)", PATR 1443 (1944) 4a) V. Lindner, "Deterioration of Propelling Charges. Determination of Effect of Rayon, Silk and Cotton Cloth Storage at 65°C with NH Smokeless Cannon Powder, M1", PATR 1626 (1946) 5) I.G. Nadel & J.S. Musgrave, "Develop Substitute Cartridge Cloth Material", PATR 1916 (1953) 6) C.E. Schildknecht, "Polymer Processes . . .", Interscience, NY (1956) 7) J.A. Robertson, "Continuous High Strength Ceramic Fibers by Pyrolysis of Inorganic-Loaded Rayon: Silicon Carbide and Alumina", AFML-TR-67-409, Contract AF 33 (615)-3881, FMC, Princeton (1967) 8) J.V. Duffy, "Pyrolysis of Chlorosilane Treated Rayon", NOLTR-69-113 (1969) 9) Kirk & Othmer 17 (1968), 168-209 10) G.B. Langlois, "Methods to Produce High Modulus Graphite Yarn", AFML-TR-68-235, Contract F33615-67-C-1753, Hitco, Gordena (1968) 11) H.F. Mack, Ed, "Encyclopedia of Polymer Science and Technology", Interscience, NY (1969), 810-47 12) J.V. Duffy, "Pyrolysis of Rayon Treated with Bis-(Chlorodiphenylphosphine)-Dicarborane and Di-

meric Chlorophospha(III)-O-Carborane", NOLTR-70-1 (1970) 13) J.V. Larsen & T.G. Smith, "Carbon Fiber Structure", NOLTR-71-66 (1971) 14) H.M. Ezekiel, "High Strength, High Modulus Graphite Fibers", AFML-TR-70-100 (1971) 15) I.N. Ermolenko & R.N. Sviridova, "About the Forming of the Structure of Pyrolytic Carbonic Fibers", Rept No FTD-MT-24-79-71, Wright-Patterson AFB, Dayton (1971) 16) F.J. Hildebrant & M. Buxbaum, "Electrostatic Measurements on New Propellant Bag Materials under Low Relative Humidity Conditions: 152mm Weapon System", PATR 4490 (1973) 17) L.W. Metker et al, "A Method for Determining Backface Signatures of Soft Body Armors", APGEB-TR-75029 (1975) 18) R.J. Diefendorf & E.W. Tokarsky, "The Relationships of Structure to Properties in Graphite Fibers. Part III", AFML-TR-72-133-PT-3, Contract F33615-72-C-1422, Rensselaer Polytechnic Inst, Troy (1975) 19) A.T. Robinson, "Evaluation of Insulation Materials for Advanced Motor Systems", Rept No NWC-TP-5693 (1976) 20) J.R. Stetson & J.C. Schutzler, "Evaluation of Carbon-Carbon Composite Nostip Materials", AMMRCC-TR-76-34, Prototype Development Assocn, Santa Ana (1976) 21) CondChem-Dict (1977), 744

Addnl Refs (Limited Distribution): 1) F.V. Ludden, "Substitute for Silk in Pyrotechnic Parachutes", PATR 526 (1934) 2) L. Zapf, "Development of Substitutes for Grade C Silk Igniter Cloth and Silk Tape", PATR 1141 (1942) 3) Ibid, PATR 1205 (1942) 4) J.H. Robinson, "Development of Alternative Parachute for Ground Signals", PATR 1299 (1943) 5) S.A. Genden, "Investigation of the Relative Abrasion Resistance of Various Cartridge Cloths", PATR 1548 (1945) 6) W.R. Wechter, "Develop Substitute Cartridge Cloth Material", PATR 1721-1 (1949) 7) F.C. Bullock & J.C. Leslie, "Optimization of Material Composites for Consumable Meteorological Rocket Motor Cases. Volume II-Appendices", Rept No ABL-TR-68-18-Vol-2, DAAH01-67-C-1502, Hercules Inc, Cumberland (1968) 8) A. Rado, "Automated Manufacturing of Three Dimensional Cloth Howitzer Propelling Charge Bags Feasibility Study", Rept No R-3212, Contract DAAA21-71-C-0447, FMC Corp, Santa Clara (1971) 9) R. Bacon, "High Strength-High Modulus Carbon Fibers", AFML-TR-66-

334-PT-6, Contract F33615-70-C-1453, Union Carbide, Cleveland (1971) 10) J.K. Leg et al, "Thermal and Mechanical Properties of Advanced Heatshield Resinous (CP) and Carbonaceous (CC) Composites. Vol 1. Test Methods, Comparative Data, Recommended Inputs and Analysis", **AFML-TR-72-160-Vol-1**, Contract F33615-69-C-1796, SRI, Birmingham (1972) 11) J.-P. Picard, et al, "Fabric Reinforced Crosslinked Cellulose Nitrate Propellants for Recoilless Weapons", **PATM 2057** (1973)

Refs: 1) H. Brunswig, "Das Rauchlose Pulver", Berlin (1926), 6-7 2) P. Tavernier, **MP 2**, 244 (1950) 3) **PATR 2510** (1958), Ger 156

RDB Cordite. See under Cordite RDB in Vol 3, C532-L

Rayon, Nitration of. Same as cellulose nitration which is covered in Vol 2, C101-R to C103-L. The rayon prod of cellulose nitration is discussed under "Cellulose Nitrates . . ." in Vol 2, C100-L to C101-R. Variations in rayon nitration techniques are presented in the following addnl refs

Addnl Refs: 1) W.E. Roseveare & L. Poore, **IEC 45**, 2518-21 (1953) & **CA 48**, 3681 (1954) 2) W.G. Harland, **JTextileInst 45**, T678-91 (1954) & **CA 49**, 607-08 (1955) 3) S. Hayama, **JChemSocJap, IndChemSect 58**, 777-79 (1955) & **CA 50**, 9745 (1956) 4) S. Hayama, **JChemSocJap, IndChemSect 58**, 919-22 (1955) & **CA 50**, 12486 (1956) 5) *Ibid*, **KogyoKagakuZasshi 59**, 392-94 (1956) & **CA 51**, 10064 (1957) 6) T. Fujimura, **Seni-Gakkaishi 17**, 632-36 (1961) & **CA 55**, 21597 (1961)

RCP (Rottweiler Cellulose Pulver; Rottweil Cellulose Propellant). The first Ger gelatinized military smokeless propnt which was invented in 1883-1884 by C. Duttenhoffer independently of P. Vieille, who invented Poudre B (qv). The first RCP was prepd at the Rottweil Plant by nitrating partially carbonized wood (the same kind as was used for the prepn of brown powder, called Pulver C/82) by a method similar to that used in the prepn of Schultze's Powder (qv). The nitrated product was stabilized by boiling w, then dried and gelatinized by means of et acet. The gelatinized product was grained either in the form of small leaflets (Blattchenpulver) for use in rifles or in the form of strips (Streifenpulver) for use in cannons

RDX

RDX, currently listed as 1,3,5-trinitro-hexahydro-s-triazine in CA, was described under **Cyclotrimethylenetrinitramine** in Vol 3, C611-L to C626-L. The last ref in the Vol 3 article is dated 1964. Since that time, much new literature has been published on RDX, clearly indicating the need for updating the previous article. Furthermore, many of the expl props listed in the Vol 3 article were obsolete even at the time of its publication and need revision

The present article is limited almost exclusively to RDX and does not consider its mixts with other expls or with binders. Emphasis will be placed on the expl behavior of RDX. Its history, prepn, standard tests and uses have been adequately described in Vol 3. There is, however, an aspect of RDX manuf that has received considerable attention lately, namely disposal of RDX wastes. This work will be summarized and will include recent studies on RDX toxicity

The present article is divided into the following sections: I. Physical Properties (recent data); II. Thermal and Thermochemical Properties; III. Reactions of and Radiation Effects on RDX; IV. Characteristics of Steady Detonation; V. Initiation Behavior; VI. Deflagration-to-Detonation Transition (DDT) and Combustion; VII. Decomposition and Kinetics; VIII. Analytical Methods; IX. Waste Disposal; X. Toxicity; XI. RDX Detonators; XII. Military Specifications; and XIII. References. Major emphasis will be placed on Sections IV, V, and VI

I. Physical Properties.

In the past there was some confusion about the *crystal density* of RDX. Now there appears to be agreement that TMD (theoretical maximum density) for RDX is 1.82g/cc (Ref 58b). Unit cell dimension in Å are $a = 13.22$, $b = 11.61$, $c = 10.72$ and the structure is orthorhombic (Ref 58b)

More recently Choi & Prince (Ref 55) used neutron diffraction measurement to determine that RDX *crystallizes* in the orthorhombic space group Pbc_a. The molecule consists of alternate CH₂ and N-NO₂ groups in a puckered ring. The environment of the carbon atoms is essentially

tetrahedral, and the N-NO₂ groups are planar. The molecule possesses a plane of approx mirror symmetry perpendicular to the plane defined by the three carbon atoms. The thermal motion may be described by rigid-body motion of the ring and separate rigid-body motion of the nitro groups. Depolarized Rayleigh scattering, IR and Raman spectra and dipole moment measurements detd that RDX in soln has C₃ symmetry with some distortion associated with the NO₂ groups (Ref 40)

Miscellaneous techniques for growing RDX crystals are described in Ref 66

Hagan & Chaudri (Ref 110) obtained *fracture surface energies* for single crystal RDX of 0.11 Joules/m² and 0.07 Joules/m², respectively, for cleavage planes parallel and perpendicular to the extended diamond-like growth features of 10 x 5 x 2mm RDX crystals grown in DMF solns. They also detd the coeff of friction of RDX vs glass to be 0.35 and obtd approx values for its Young's modulus (1.8×10^{10} N/m²) and Poisson's ratio (0.22)

The *vapor pressure* p of RDX from 111 to 130°C is given by $\log p = 10.87 - (3850/T^{\circ}\text{K})$ (Ref 58b) and $p = 10^{-7}$ Torr at 48°C (Ref 25)

The *dipole moment* of RDX in highly polar solvents is approx 7D (Ref 33)

Iqbal et al (Ref 56) measured the transmission infrared and laser excited Raman spectra of polycrystalline RDX in the range of 40 to 4000/cm. To aid assignments in the spectral region of 400 to 4000/cm, the spectra of two types of N15-labeled samples and the soln spectra in different solvents were also recorded. From these data it was possible to assign many of the observed bands to intramolecular modes of the RDX molecule. The Raman-active lattice modes also were resolved and found to be comparable to the lattice mode frequencies in solid cyclohexane

Spectroscopic data (Ref 80) show that RDX *force constants* are similar to those of non-expl molecules. Thus the expl nature of RDX cannot be explained by the presence of weak bonds

Optical absorption measurements have confirmed the reports of earlier workers that the solid forms of the cyclic polynitramines known as RDX (and HMX) have a weak absorption band in the near ultraviolet which is not observed in spectra of the solvated compds. Fluor-

escence measurements on solid samples of these materials show a weak emission, the excitation spectrum of which corresponds to this absorption band. The fluorescence is not observed in the solvated compds. Phosphorescence measurements on the solids reveal a long-lived emission, the excitation spectrum again corresponding to the band observed in absorption and fluorescence excitation. The lifetime of this emission was found to be substantially increased by deuteration. The absorption and luminescence bands are attributed to charge-transfer self-complexation in the solid state. Charge-transfer singlet and triplet excited state energies are estimated (Ref 81)

The *sound velocity*, c_0 , of single crystal RDX is quoted in Ref 84 as 2.55km/sec. Extrapolation of Hugoniot data (see below) gives $c_0 = 2.87\text{km/sec}$ for RDX at 1.8g/cc (Ref 34). The writer (Ref 37) found that sound velocity of pressed RDX pellets varies with packing d , particle size, and temp as follows:

Average particle size (microns)	Density (g/cc)	Temp ($^{\circ}\text{C}$)	c_0 (km/sec)
17	1.64	25	2.80
17	1.58	180	2.45
5	1.54	25	2.3
18	1.54	25	1.0
60	1.54	25	1.4

It is likely that c_0 in these compacts is largely controlled by the degree of "bridging" between particles. The most "crumbly" pellets had the lowest sound velocity

Hugoniot data (see Vol 7, H179-L to H185-L) for unreacted expls is difficult to obtain. Data obtd by the writer (Ref 37) for 1.64g/cc RDX at 25 $^{\circ}\text{C}$ can be expressed as:

$$U = 1.93 + 0.67u \quad \text{for } 0.11 \leq u \leq 0.35$$

$$U = 0.70 + 4.11u \quad \text{for } 0.35 \leq u \leq 0.47$$

where U = shock velocity and u = particle velocity

For 1.58g/cc RDX at 180 $^{\circ}\text{C}$:

$$U = 0.71 + 4.2u \quad \text{for } 0.25 \leq u \leq 0.32$$

Varying RDX particle size for 1.54g/cc pressings did not change the Hugoniot, as shown in the tabulation below

All these data fit on a single Hugoniot curve

Ilyukhin et al (Ref 4) give

$$U = 2.87 + 1.61u \quad \text{for } 1.8\text{g/cc RDX}$$

Dremin et al (Ref 34) give

$$U = 0.4 + 2.00u \quad \text{for } 1.0\text{g/cc RDX}$$

They also list the following *Grueneisen constants*, γ :

v (cc/g)	γ
0.551	2.6
0.544	2.66
0.539	2.63

and $\gamma = vp_t/E_t$, where v = specific volume and p_t and E_t are the thermal components of pressure and energy

Erkman and Edwards (Ref 103) used $\gamma = 2.6$ and $c_0 = 2.87\text{km/sec}$ for voidless RDX to compute Hugoniot data for 1 g/cc RDX and obtd excellent agreement with the above exptl data of Dremin et al

Average particle size (microns)	P_0 (kbar)	U_0 (mm/ μ sec)	u (mm/ μ sec)	V (cc/g)
60	6.6	1.70	0.250	0.553
18	7.9	1.75	0.292	0.538
18	9.0	1.73	0.335	0.523
5	9.2	1.90	0.323	0.541
60	10.9	1.92	0.377	0.522
18	11.0	1.90	0.380	0.521
60	11.0	1.93	0.375	0.523
5	11.1	1.88	0.380	0.518
5	17.0	2.39	0.475	0.522
5	17.4	2.38	0.483	0.517
18	18.1	2.4	0.486	0.52
5	22.7	2.80	0.586	0.528

II. Thermal and Thermochemical Properties

Thermal conductivities and diffusivities and specific heats of RDX were measured in the range of 222 to 450°K (Ref 92). Unfortunately no data are given in CA and we were unable to obtain the original report. Licht (Ref 39a) gives the thermal conductivities at 1.26 and 1.53g/cc as 6.9×10^{-4} and 7.0×10^{-4} cgs units, respectively

The *specific heat* of RDX is 0.398cal/g·°C at 20°C and its variation with temp is shown in Fig 1 (Ref 58b)

The linear coeff of thermal expansion for single crystal RDX is shown as a function of temp and crystal orientation in Fig 2 (Ref 54)

Approx linear expansion coefficients obtained by the writer (unpublished data) for 1.63g/cc RDX pellets ranged from $(5-8.5) \times 10^{-5}$ cm/cm·°C for temps of 103 to 182°C

Hall (Ref 41) lists the *melting point* of RDX as 205.5°C which is 1.5°C higher than the value given in Ref 58b

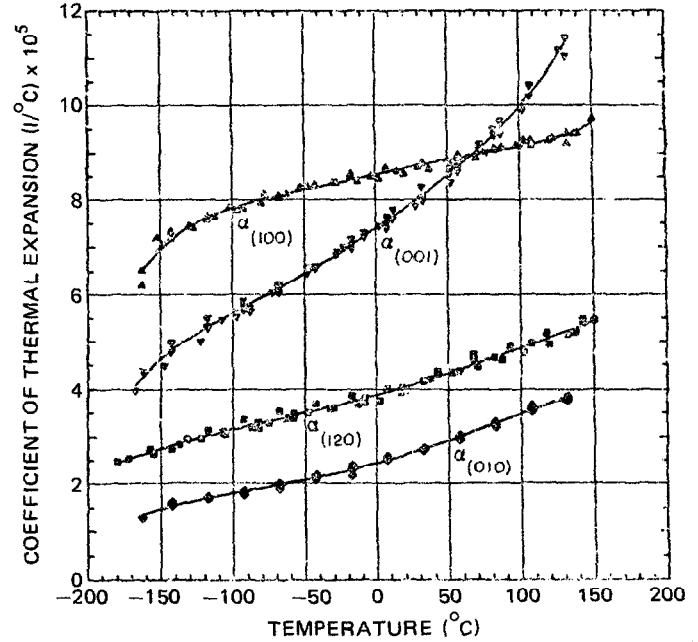

Fig 2 Linear Coefficients of RDX

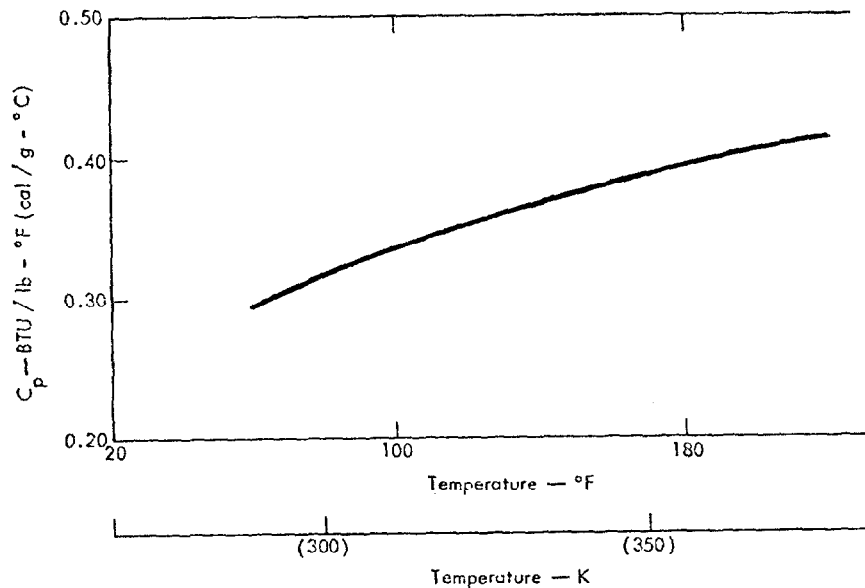

Fig 1 Specific heat C_p of RDX as a function of temperature. Conversion $1 \text{ BTU/lb}\cdot\text{°F} = 1 \text{ cal/g}\cdot\text{°C} = 4.184 \text{ kJ/kg}\cdot\text{K}$

Thermochemical data for RDX are given in Tables 1 & 3 on pp H41 and H44 of Encycl Vol 7. For convenience they are summarized below:

Standard heat of formation: +14.71kcal/mole
Heat of fusion (at 478.5°K): 8.5kcal/mole
 7.3kcal/mole
 (Ref 111)

Heat of vaporization: 26kcal/mole
Heat of sublimation: 31.1kcal/mole

Of the above values the heat of vaporization is probably the least trustworthy

N-N bond strength: 46kcal (Ref 120)
C-N bond strength: 60kcal (Ref 120)

III. Chemical Reactions of RDX and Radiation Effects on RDX.

Recent studies on the chemical reactions of RDX appear to be focussed on elucidation of its molecular structure and bond breakage or re-arrangement, rather than the formation of new RDX-like compds. The effects of high-energy radiation on RDX have also been examined

An extensive study by Stals (Ref 36a) has described the mass spectral fragmentation of RDX and HMX in terms of their metastable transitions, mass measurements and ionization efficiency curves. The ring migration of an NO₂ group is noted. The known interrelation between the thermal, photochemical and mass spectral fragmentation of RDX is rationalized in terms of the common bond strength inequality CN < NN < NO, which holds for its ground and lowest excited states, as well as the ground and first excited doublet state of its cation. The same rationale applies to s-N,N-dimethyl nitramine and alpha- and beta-HMX

A theoretical study by the same author suggests that RDX forms charge transfer complexes upon crystn which are unique because their charge transfer exciton band is of lower energy than the singlet exciton band of their molecular crystals. Static reactivity indices were used to predict the likely primary dissociative products obtainable from each excited state of secondary nitramines; theory predicts that the axial and equatorial nitramine groups of the polynitramines RDX, alpha- and beta-HMX, may possess quite novel selective decompn paths and hence give different primary dissociative products

According to Abel et al (Ref 119) the complexing behavior of energetic materials has begun to emerge as a subject of importance to those involved in the formulation of expl and proplnt compns. Casting, rheological, and detonation or burning props of compns can be affected by the incorporation, deliberately or accidentally, of complexes involving energetic compds. All too often the nature of the forces which bind the components of the complex is not understood, and cannot be exploited. A bibliography gathers together the known literature refs to complexes involving RDX, HMX, and TNT, as well as some related nitramines and nitroaromatics. Because there is belief that crystals of RDX and HMX are at least partially bound together by charge-transfer complexing forces, refs to the known cryst structures of some of the intermediates in RDX and HMX synthesis have been detd, and refs to these structures are also included

High-energy radiation has been used to study the decompn of RDX as well as its effects on changing the expl props of RDX

Stals (Ref 36a) found that the e.p.r. spectra of polycrystalline RDX, and its single crystals, when irradiated with gamma-radiation and 254nm light at 77–298°K, indicate that the NO₂ radical may be a primary photochemical product of RDX. Mass spectral analyses of the gaseous products suggested that N₂ and NO may also be primary photolysis products of RDX. The identity of these products was consistent with the theoretically predicted bond cleavage patterns of the axial and equatorial nitramine groups of RDX and HMX. A combination of theory and expt thus permitted the tentative assignment of the primary photochemical steps for polycrystalline RDX

Cherville (Ref 45) exposed both solid and dissolved RDX to γ -radiolysis. Radiolysis in the solid state showed a delayed decompn, resulting from the diffusion of NO₂ created and trapped during the irradiation. He concludes that RDX is a radiation-resistant expl

Similar results were obtbd by Avrami & Jackson (Ref 90) who subjected HMX, RDX, HMX/RDX mixts and Comp B to low level long-term Co60 gamma radiation (225R/hr for 90, 120, and 150 days). Differential thermal analysis, thermogravimetric analysis, weight loss detn, and vac stability, infrared spectrometry, impact sensi-

tivity and expln temp tests were used. It was found that the thermal stability and sensitivity of these expls were not adversely affected by the exposures

In a previous study, these authors (Ref 63) also used Co60- γ radiation of up to 10^9 R to determine that RDX is resistant to this radiation as gaged by post-radiation examination of wt loss, dimensional change, vac stability, DTA, TGA, infrared spectra, mp, impact sensy, expln temp and rates of deton

Cerny et al (Ref 8) used π mesons to irradiate RDX (and other expls). No explns or signs of thermal decompn were observed

IV. Characteristics of Steady Detonation.

A. Detonation Velocity.

The most readily measurable characteristic of a steady deton is D , its deton velocity. Thus it is not surprising that there is good agreement among published values of D . For example, at charge densities approaching TMD:

$D = 8754$ m/sec (Ref 6); $D = 8800$ m/sec (Ref 58b); and $D = 8800$ m/sec (Ref 3)

The dependence of D on the charge density, ρ , is given in Ref 58b as $D = 2560 + 3470\rho$ for $\rho > 1$ g/cc

In liq H_2 , 24mm diam 50/50 RDX/TNT charges of 1.68g/cc deton stably at a rate essentially equivalent to their room temp D (Ref 82). This is strong indication that 100% RDX charges will behave similarly

Addition of microporous urea greatly reduces RDX charge d . Such mixts deton stably down to $\rho = 0.05$ g/cc (Ref 48). Aleksandrov et al (Ref 19) measured the variation of D with charge diam d for coarse RDX at 1 g/cc. For $d = 18$ mm, $D = 5030$ m/sec; for $d = 22$ mm, $D = 5140$ m/sec; for $d = 30$ mm, $D = 5800$ m/sec; and for $d = 40$ mm, $D = 6000$ m/sec. In all cases the particle size of the RDX was 1.8mm

The deton vel of RDX and PETN monocrysts, along their different crystallographic axes, was investigated in Ref 43. Data obtd by rotating mirror camera recordings revealed a weak anisotropy of deton vel with cryst geometry

RDX, particle size of 1 to 1.6mm at 1 g/cc packing d , contd in cellophane tubes of around 15mm diam, exhibited a very narrow region of pseudo-stable low velocity detonation (LVD)

when initiated with a booster of $D = 2000$ m/sec (Ref 13). The LVD rate was also of the order of 2000m/sec. At diams above 15mm, LVD transformed into normal D as shown in Fig 3

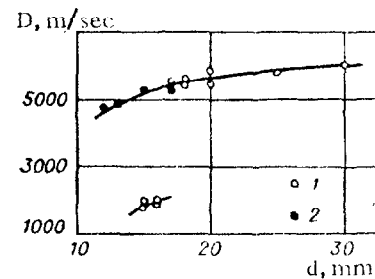

Fig 3 Steady-state detonation velocity of RDX ($\rho_0 = 1.0$ g/cm³, particle size 1.0–1.6mm) on charge diameter. 1) Weak initiator; 2) strong initiator

Krivchenko et al (Ref 50) studied the deton parameters of RDX mixed with a variety of liqs of different densities (ranging from acet at 0.79g/cc to bromoform at 2.81g/cc). Their results are summarized in Table 1

We see from Table 1 that the deton parameters for the filled systems are higher than those for RDX charges (of 0.3 to 0.5mm grains) at 1.03g/cc, approaching and sometimes exceeding the values of one or all of the deton parameters of pure RDX at $\rho_0 = 1.44$ g/cc (this d is approx equal to the avg d of the system). It should be noted that there is a sharp increase in the press of the filled system because of the simultaneous increases in the deton vel, the mass vel, and the avg charge d

The polytropic indices of the systems, Γ , vary from 2.9 to 3.75 with the different fillers; these values are slightly higher than those in pure RDX at the same pressures

The methods of obtaining τ and "a" are described in Subsection E below. As a rule, the chem-reaction times in the filled systems are shorter than those in 1 g/cc RDX charges without a filler, but longer than for charges of pure RDX at 1.44g/cc. With approx equal pressures for the RDX-filler and pure-RDX systems at $\rho_0 = 1.44$ g/cc, this result can be attributed to the lower avg temp in the reaction zones of the filled systems. Since the product Du is proportional to the heat of deton and thus related to

Table 1 (from Ref 50)
Detonation Parameters of RDX Mixed with Liquids of Different Densities

Filler	c, wt %	ρ_1 , g/cm ³	ρ_0 , g/cm ³	D, km/sec	u, km/sec	p, kbar	D.u, km ² /sec ²	τ , μ sec	a, mm	Γ
--	--	--	1.03	6.0	1.56	95.0	9.35	0.67	2.50	2.80
--	--	--	1.44	7.53	1.80	195.2	13.60	0.24	1.12	3.18
Paraffin	24.0	0.90	1.34	8.11	1.85	202.0	15.00	0.42	2.44	3.40
Acetone	24.5	0.79	1.35	6.92	1.62	153.0	11.20	0.48	2.37	3.30
Alcohol	25.0	0.81	1.36	7.15	1.80	176.0	12.85	0.48	2.34	3.00
Acetone solution	27.5	1.00	1.43	7.00	1.73	173.0	12.11	0.47	2.30	3.05
Water	27.5	1.00	1.43	7.60	1.60	174.0	12.15	0.45	2.52	3.75
64% NH ₄ NO ₃ solution	36.0	1.37	1.61	8.08	1.85	240.0	14.95	0.30	1.77	3.36
54% NH ₄ I solution	36.0	1.37	1.61	7.10	1.52	174.0	10.80	0.54	2.20	3.68
64% NH ₄ I solution	41.0	1.61	1.73	7.07	1.51	185.0	10.70	0.54	2.80	3.70
Mononitromethane	32.0	1.14	1.51	7.63	1.95	214.0	14.88	0.49	2.55	2.92
CCl ₄	38.0	1.51	1.68	7.05	1.75	210.0	12.30	0.72	3.50	3.02
Bromoform liquid	51.0	2.81	2.21	6.27	1.45	200.0	9.10	0.95	4.23	3.33
solid	52.0	2.85	2.25	6.15	1.47	202.0	9.05	0.75	3.30	3.17

Footnote to Table: Here ρ_1 and ρ_0 are the initial filler density and the density of the system, u = particle velocity, τ = chemical reaction time, a = reaction time zone width, and Γ = polytropic index

temp, it should correlate with τ . As seen in Table 1, there is a rough correspondence between Du and τ

Urbański (Ref 53) also studied the effect of addition of such non-solvent liqs as H₂O, C₇H₁₄, CHCl₃, iso-C₅H₁₁OH, glycerol, castor oil, o- and p-nitrotoluene, PhNH₂, and glycerol triacetate, on the deton rate of RDX. He also found that as liq content increased, the D vs % liq curve passes thru a max. Kegler (Ref 65) investigated the effect of the addition of w and aq solns of amm nitrate or hydroxide, hydrazine or nitric acid on the D of RDX. Unfortunately his data are unavailable to us

The writer (unpublished work) thru a semi-empirical approach developed the concept that the Gurney constant ($\sqrt{2E}$) of an expl is approx D/3. The Gurney constant for RDX is given in Ref 58a as 2930m/sec

B. CJ Pressures.

There is considerably more disagreement in the published values of CJ Pressures, P_{CJ}, for RDX than there is in published values of D. This is illustrated below:

Density, (g/cc)	P _{CJ} (kbar)	Ref
1.80	390	4
1.80	347	6
1.767	338	58b
1.755	366	2
1.63	284	10
1.59	287	2
1.44	196	50
1.40	213	2
1.20	152	2
1.00	104	2
1.03	95	50

Hollenberg's measurements (Ref 64) of P_{CJ} for RDX are not available to us and cannot be included in the above tabulation. Compared with the other data the P_{CJ}'s of Ref 2 appear to be too high

Kuznetsov and Shvedov (Ref 29) suggest an interpolation formula for the dependence of P_{CJ} on ρ_0 , namely

$$P_{CJ} = 22\rho_0 + \frac{85\rho_0^3 + 5\rho_0^2}{1 + 0.2\rho_0^2}$$

Their rather complex equation of state (EOS) for RDX deton products is given below (DP = detonation products):

$$p = p_0 + \frac{1}{v} \gamma (E - E_0 - \Delta)$$

$$p_0 = 15.4 \rho^3 - 12.6 \rho^2 \cdot 1000 \text{ atm}$$

$$E_0 = 0.77 \rho^2 - 1.26 \rho \text{ kJ/g}$$

$$\Delta = \frac{0.14 T \theta}{(\exp \theta - 1)} \left[1 - \frac{\theta \exp \theta}{\exp \theta - 1} \right] \text{ cal/mole}$$

$$\gamma = \frac{R \phi}{c_v^* + 0.3 R (\phi - 1)}$$

$$\theta = \frac{3200}{T}, \quad T = 10^3 \cdot T^*$$

$$\phi = 1 + \frac{2.7 \tau^4 + 15 \tau^2}{1 + 2.6 \tau^4}, \quad \tau = 0.72 \rho (T^*)^{-0.3}$$

$$T^* = 0.3 \frac{p - p_0}{p \phi}$$

$$c_v^* = \frac{1.76 R \theta^2 \exp \theta}{(\exp \theta - 1)^2} + 2.624 R$$

Here, v_1 , E_1 and v_* , E_* are the specific volume and specific internal energy for the starting state of the expl and for the state at the Chapman-Jouguet (C-J) points, respectively; p_* is the pressure at the C-J points; p , v , ρ , E and T are the press, specific volume, density, specific internal energy, and temp of the DP respectively; $Q(v_1)$ is the heat of expl; p_0 and E_0 are the elastic components of pressure and energy which depend only on density; γ is the Grüneisen constant of the DP;

$$\Delta \equiv \int_0^T (c_v/\mu) dT - c_v T/\mu;$$

$\phi = \phi(\rho, T)$ is a function entering into the expression for the thermal component of the pressure

$$p = p_0 + \phi(\rho, T) \frac{\rho R T}{\mu},$$

for an ideal gas with $p = 0$ and $\phi = 1$; c_v^* is the specific heat of the ideal gas mixt; and μ is the mw of the DP

According to this EOS, computed P_{CJ} (Ref 29) are as follows:

ρ_0 (g/cc)	P_{CJ} (kbar)
1.8	343
1.6	264
1.4	204
1.2	100
0.8	64

These computed values compare well with exptl P_{CJ} 's in the previous tabulation. Ref 29 also gives computed values for density, particle velocity (U), internal energy and temps at pressures greater than P_{CJ} . The following interpolation is proposed:

$$p = kU + 4U^2 + U^3$$

The coefficient k is a function of ρ_1 . In the range $\rho_1 = (1.2-1.8) \text{ g/cm}^3$, $k = 117\rho_1 - 71$ and $k = 96\rho_1 - 45$ at $\rho_1 = (0.7-1.2) \text{ g/cm}^3$. The same authors (Ref 19c) by numerical solution of $(dE)_s = pdp/\rho^2$, in conjunction with the above EOS, give tables of data for the isentropic expansion of the DP for RDX

C. Heat of Detonation.

The heat of detonation of RDX at $\rho_0 = 1.7 \text{ g/cc}$ was measured calorimetrically by Apin and Lebedev (Ref 1a) to be 1.51 kcal/g. More recently Vashchenko et al (Ref 42) found that addition of w to 1.14 g/cc RDX linearly increases its heat of deton up to a w content of 24%.

Indeed the heat of deton of the low d compacts with w approaches that of dry RDX at 1.7 g/cc. It is claimed that both chem analyses and thermochemical measurements point to the view that the presence of w strongly favors the "soot" reactions $2CO = CO_2 + C$ and $CO + H_2 = H_2O + C$ because of increase in pressure in the system under study. Both these reactions are highly exothermic

Similar conclusions were reached by Zygmunt (Ref 98)

D. Critical Diameters.

Apin & Stesik (Ref 1) show that the critical diameter, d_{cr} , for 1 g/cc RDX varies with RDX particle size, μ . For $\mu \approx 0.1 \text{ mm}$, particle size $d_{cr} \approx 2.5 \text{ mm}$; and for $\mu \approx 0.4 \text{ mm}$, $d_{cr} \approx 5 \text{ mm}$. Apin & Velina (Ref 19b) apparently studied the effect of ρ_0 and particle size on d_{cr} . Unfortunately their original article is unavailable to us. From the terribly uninformative and confusing CA article it appears that for large RDX grains, $d_{cr} = 19 \text{ mm}$, if $\mu < 4 \text{ mm}$ (ρ_0 not given; possibly CA should read " $\mu > 4 \text{ mm}$ "). D under these essentially unspecified conditions is $3/4 D_{ideal} = 4500 \text{ m/sec}$. Critical diameter passes thru a max with increase in μ , in both air and w -filled RDX compacts

Fine RDX ($\mu \approx 0.1 \text{ mm}$) 95/5 RDX/paraffin compacts at 1.05 g/cc were found to have $d_{cr} \approx 5 \text{ mm}$ (Ref 97). These were independent of paraf-

fin content up to 28%, the max content examined. However, with talc added to RDX, d_{cr} goes thru a max of about 9mm at 40% talc content

Afanas'ev & Bobolev (Ref 45b, p 99) quote d_{cr} for single crystal RDX as 7mm; this despite the well-established fact that d_{cr} decreases with ρ_0 for most expls

E. Reaction Zone Width.

Aleksandrov et al (Ref 19) used an electromagnetic technique to get particle velocity (u) vs time profiles. They conclude that the breaks observed in such profiles coincide with the Chapman-Jouguet point, ie, the time of the break corresponds to the chem reaction time in a detonation. The reaction zone width, a , is then

$$a = \tau(D - u)$$

For RDX crystals of 1.8mm particle size at 1 g/cc, they obtained the following:

d=charge diam (mm)	a=reaction zone width (mm)
18	3.2
22	2.9
30	2.9
40	2.5

These values are appreciably greater than those obtained from studies of the variation of D with charge diameter

A recent article (Ref 50; see Table 1 of Sub-section A above) lists $a=1.1$ mm for 1.44g/cc RDX. Addition of various liqs generally increases the reaction zone width, as shown in Table 1

F. Characteristics of RDX Detonation Products.

Volk (Ref 105) measured the fumes produced by the deton of RDX by gas chromatographic and chemiluminescence techniques. He identified H_2 , N_2 , CO_2 , CO , H_2O , CH_4 , C_2H_6 & C_2H_4 (chromatography) as well as NO and NO_2 (chemiluminescence) in the products. Shots were made in air and in argon. As little as 4% air in Ar markedly increased the NO content of the products

Kuznetsov et al (Ref 68) used Lennard-Jones potentials to compute the thermodynamic functions for most deton products over the range of 1500–4500°K for RDX at ρ_0 of 0.1 to 1 g/cc

Korotkov et al (Ref 52) compare computed shock wave pressure and deton gas expansion pressures (bubble pressures) with exptl values for the underwater expls of RDX and PETN

Yakushev and Dremine (Ref 86) claim that the observed electrical conductivities of RDX/TNT

(and other expl) detonation products are primarily due to ions formed by the dissociation of w and other products under the influence of the high temps and pressures existing during deton. In a later paper (Ref 87) these authors examined the electrical conductivity of the products of pressed cylindrical charges of RDX. They claim that such deton products will be conductive under the existing high pressure environment regardless of whether there is chem reaction. Ershov and coworkers (Refs 83 and 69), on the other hand, claim that the chem reaction zone in a deton can be correlated with the non-equilibrium ionization observed in deton products. They find (Ref 69) that the electrical conductivity of the deton products of RDX goes thru a max of 43 (ohm-m)^{-1} at 0.3mm behind the deton front. They advance three possible explanations for this observation: (1) high d ; (2) thermoionization; and (3) chem reaction. They claim that explanation (1) is untenable because d drops monotonically behind the detonation front. Similarly (2) is incorrect because conductivity due to thermoionization is expected to be 4–5 orders of magnitude less than the observed conductivity. Consequently it is claimed that chem reaction is the correct explanation

G. Detonation Light and Output Energy.

Blackburn & Seely (Ref 11) made a careful study of the light emerging from detong granular expls, one of which was 25 micron RDX. They found that pressed RDX charges in air or in methane gave very similar deton light. They also noted that the light intensity and the recorded line width decrease as the packing d of charge increases from 71 to 96 TMD. Based on these results and observations with other expls, Blackburn & Seely conclude that chem reaction or shocked interstitial gases have little bearing on deton light, which is likely to be produced by the expansion of deton products of one grain, and their stagnation against the next grain

Hershkowitz and Akst (Ref 101) studied means of improving the performance of composit expls contg Amm nitrate. In their study they detd the dents produced in witness plates by a confined column of RDX (9.65mm ID, 76.2mm long). For RDX at 1.72g/cc, dent depths averaged 3.53mm and ranged from 3.47 to 3.61mm

V. Initiation Behavior.

Various modes of initiation of expls were described in Vol 7, I106-L to I109-L. Some of these modes as they apply to RDX will be discussed below

A. Impact

This mode of initiation is described in detail in the article on *Impact Initiation* in Vol 7, I35-R to I55-R. In particular, refs to RDX are to be found on pp I41, 42, 50, 51, 52 & 54 of that article. For the sake of completeness, however, we quote below, from Ref 45b, the major criteria for the impact initiation of RDX:

critical unconfined charge thickness: 0.25mm

critical pressure: 7000kg/cm²

min impact force: 1.3×10^5 kg

The results of a recent study (Ref 62) on the effects of solid additives on the impact initiation of RDX are summarized in Table 2

Note that the best desensitizers have large values of specific heat. Conversely additives that are hard and/or have high melting points tend to sensitize RDX to impact. Liq additives are claimed to fill pores and thus reduce the incidence of hot spots. All of the above, and the observed effects of changing the heat conduction path between the impact app and the test sample, are claimed as support for the point of view that desensitization occurs via heat absorption from hot spots by additives or app

Studies at the Cavendish Labs in Cambridge (Refs 109 & 67b) suggest that mechanical props of an expl have important bearing on its initiation behavior. High speed photography was used to follow the processes preceding the impact and friction initiation of RDX and other expls. It was found that the sample may undergo plastic flow in bulk, show evidence of partial

Table 2
Physical Properties of Solid Additives and 50% Heights of RDX Compositions

Additive	Specific heat, cal/g/°C	Mp, °C	Heat of fusion, cal/g	Hardness, kg/mm ²	Particle-size range, μ	50% ht, cm
Graphite	0.17 ^a	3500 ^{a,b}	—	—	44–53	22
Sulfur	0.18 ^a	119 ^a	—	—	44–53	19
Lead acetate.3H ₂ O	0.18 ^c	—	—	—	53–177	22
Teflon	0.25 ^a	—	—	4.0	—	31
Fluorowax	—	—	—	—	177–350	28
Mylar	0.26 (25°C) ^d	250 ^e	17 ^d	25	53–105	19
Strontium chloride.6H ₂ O	0.27 ^c	—	—	—	53–105	32
Sodium acetate.3H ₂ O	0.34 ^f	—	—	—	53–105	35
Carbowax 1000	0.38 ^c	37–40 ^e	37 ^e	0.1	—	66
Carbowax 1540	0.38 ^c	43–46 ^e	37 ^e	0.25	105–210	48
Carbowax 4000	0.38 ^c	53–56 ^e	43 ^e	1.0	53–105	38
Carbowax 6000	0.38 ^c	60–63 ^e	46 ^e	3.5	105–210	31
Carbowax 20M	0.38 ^c	—	41 ^e	3.0	105–177	31
PAM 50	0.38 ^c	250 ^{e,g}	—	22	44–53	25
Biphenyl	0.38 ^a	71 ^a	30 ^a	1–2	177–350	40
Aerawax C	0.42 ^c	140 ^e	—	0.9	<44	21
—	—	—	—	—	44–53	52
—	—	—	—	—	105–210	39
Polyethylene (Dylan)	0.5 ^{a,h}	200 ^{e,i}	—	5.5	<44	21
Polyethylene (8416)	0.5 ^{a,h}	97–102 ^e	—	1.2	105–177	41
Polyethylene (8417)	0.5 ^{a,h}	88–90 ^e	—	0.6	105–177	47
Superla wax	0.7 ^{f,j}	75 ^e	—	0.5	53–105	112
—	—	—	—	—	53–105	130
—	—	—	—	—	177–350	111

^aWeast (1970); ^bSublimes; ^cCalculated by Kopp's rule; ^dSmith and Dole (1956); ^eData from manufacturer; ^fLange (1967); ^gDecomposes; ^hValue for high, medium, and low-density polyethylene; ⁱSoftening point; ^jValue for paraffin wax

melting, and even (with PETN) melt completely. Initiation, when it took place, always did so after break-up of the sample. In micro-particle impact experiments the possibility of localized plastic flow was assessed; flow caused by adiabatic shear was shown to be important during particle-impact initiation of some explosives.

The latter stages of the initiation of thin layers of explosive (RDX, PETN, Dina, etc), the usual condition in an impact test, are considered by Bobolev et al (Ref 24). The processes involved in producing an apparent LVD are described as follows:

"In the event of local initiation of a thin layer of explosive compressed between rigid surfaces, the process of development of explosion begins in the form of quite slow combustion. An important factor with a favorable influence on the development of the process is the fact that the charge was initiated in a closed volume. The gaseous decomposition products released during combustion sharply raise the pressure in the volume of reacted material. The increase in pressure causes the hot combustion products to penetrate into and ignite the material not affected by the decomposition reaction, which leads to a further increase in pressure and burning rate. In this stage, the development of the process is of the avalanche type and the flame propagation velocity rapidly increases to hundreds of meters per second. In this case, the combustion products, being in an enclosed volume, move away from the initiation center behind the accelerating flame front and, like a piston, are preceded by a compression wave. As the flame front accelerates, the amplitude of the compression wave increases. On reaching a sufficient intensity, this wave causes the deformation and destruction of the layer of explosive ahead of the flame front

The process of deformation of the explosive in the zone subjected to wave compression produces reaction centers similar to those formed when an explosive is subjected to mechanical stresses. The formation of centers in the compression wave is also the condition that determines the possibility of further development of the explosion. The development of centers leads to the formation of an ignition front which, in turn, becomes a source of additional reinforcement of the compression wave, compensat-

ing for its attenuation. Thus, when the velocity of the process becomes approximately constant and equal to 800–2000m/sec, a compression wave with a pressure sufficient to initiate a chemical reaction in the individual centers is propagated through the explosive

If an energy balance between the heat released in the wave and the heat losses is maintained, the process of propagation of the explosive reaction is stabilized. If the experimental conditions exclude the possibility of transformation of the above-mentioned configuration of the compression wave profile into a shock wave with a steep front, then, clearly, this regime will be stable over a certain length of the charge. There are a number of factors that affect the stability of low-velocity regimes. As follows from the experiments, one of these is a change of density along the length of the charge. Another possible factor is a change in the characteristics of the case, etc. In our opinion, incompleteness of the explosive reaction in the wave front has an important influence on stability"

Transformation of the apparent LVD into a stable detonation is envisioned as follows:

"These processes can easily be understood by considering the characteristics of the compression wave profile. When a wave with a gradually increasing pressure in the front encounters a medium of lower density (ie, with higher compressibility), the initial elements of the wave with lower pressure are propagated thru it at a low velocity, compacting it. The following high-pressure elements of the wave move thru the denser medium at a greater velocity, and so on. Thus, on passing from the compressed to the uncompressed zone, the steady-state low-velocity regime breaks down: the compression wave is rapidly (in 10–20 μ sec) transformed into a shock wave with a steep leading front and initiates normal detonation in the uncompressed layer of explosive, that is, if the pressure in the shock front is greater than the initiation pressure for the given explosive under these conditions. In fact, as noted above, the pressure in the front of a steady-state low-velocity regime entering a low-density uncompressed layer is of the order of 2–5kbar"

B. Heat

Stein (Ref 16) considered the factors involved in computing times to explosion of heated explosive

samples (including RDX). The most important data required in the calcn of time to expln for an expl subjected to an elevated temp is the kinetics of thermal decompn of the expl. In computing times to expln, activation energy, frequency factor, type of kinetic expression, and their interrelationships transcend in importance all other physical and chem props of the expl. Two mathematical models which describe heat conduction in an expl accompanied by simultaneous internal generation of heat from thermal decompn of the expl were studied. The boundary and initial conditions for one model were such that an infinite slab of expl of finite thickness, initially at a constant temp, was suddenly exposed to a constant temp on its lower surface while its upper surface was perfectly insulated. The other model was that of a semi-infinite solid initially at a constant temp which suddenly has its surface exposed to an elevated constant temp

Afanasenko & Danilenko (Ref 84) ignited liq-filled RDX samples by compression with elastic waves. The fillers used were w, CCl₄ and hexane. It is claimed that the compression wave heats the liq which then heats the RDX and ignition of the latter occurs on its surface

Hot wire ignition of RDX was studied by Klochkov & Manachinskii (Ref 67). They ignited RDX tablets, 10mm in diameter and 0.6mm thick, with metal wires heated by condenser discharge and measured ignition delays as a function of ambient pressure. For a Ni wire of 20 micron diameter and resistance of 0.9 ohms, with a 1 microF condenser, they obtained the following:

Ambient pressure (kg/cm ²)	Min Ignition voltage	Ignition delay (microsec)
1690	80	40 ± 1
6400	66	23 ± 1
12600	65	15 ± 1

With a 70 micron Mo wire at 1690kg/cm² the observed delay was 30 ± 2 microsec, and with a 20 micron W wire also at 1690kg/cm² the delay was 18 ± 3 microsec. For the former, the wire temp was estimated to be 2620°C and 3380°C for the latter. Clearly the ignition delay is not strongly dependent on wire temp

The effect of conducting and non-conducting additives on the spark initiation of RDX was

examined by Mel'nikov & Nikitin (Ref 51a). Combustible metal additives (Al, Mg, Zr) lower the min ignition energy. Other additives, (graphite, bronze and talc) increased ignition energy. Talc had the greatest desensitizing effect. The best sensitizer was Al powder, which decreased ignition energy about 60% when added to RDX in 1% amts

A 4000 volt discharge from a 1 microF condenser thru a 2-mil diam gold wire initiated high-order deton in RDX and other secondary expls. Build-up to deton under these conditions is slower for RDX than for PETN (Ref 15)

Low order explns in thin layers of PETN, RDX, DINA and Tetryl, compressed to 1200–1500kg/cm², were studied photographically. Hot spots were simulated in the expls by a 0.15mm diam heated resistance wire. Low-order explns propagated from these hot spots. The propagation rates for PETN, RDX, DINA, and Tetryl were 700–800, 700, 550, and 300 m/sec, respectively (Ref 14)

C. Lasers.

Lasers have been used to initiate deton in RDX. Three types of initiation mechanisms have been described (Ref 102): (1) instantaneous deton caused by a shock wave in a thin metallic film (deposited on the expl) with the shock wave generated by a Q-switched laser pulse; (2) instantaneous deton by direct interaction of a Q-switched laser pulse and the test expl; and (3) DDT produced by free-running laser pulses. Coarse RDX cannot be initiated, but milled RDX (particle size less than 40 microns) is readily initiated at various packing densities. The threshold fluences for the initiation of 1.18g/cc & 1.52g/cc milled RDX via mechanism (1) are 45.3J/cm² and 127.9J/cm², respectively. Detons are either essentially instantaneous or the sample burns without deton. For direct initiation [mechanism (2)], the threshold laser energy for 1.18g/cc RDX was 0.8J, or the same as in thin film initiation. However, deton was no longer "instantaneous" but required about 2 microsec for build-up. The 1.52g/cc RDX was initiated directly without delay (laser energy not given)

Low energy (less than 10 J) free-running mode lasers will not generate intense shock waves in films or expls. They can be used to initiate expls via the DDT route. RDX columns

2.5mm in diam and at least 25mm long exhibited deton when exposed for 560 microsec to a 4J neodymium laser, and for 240 microsec with a 5J ruby laser

Barbarisi & Kessler (Ref 26) examined the possibility of using ruby laser initiation in practical expl systems. The secondary expls examined included PETN, HMX, RDX and Tetryl. Most of the effort was devoted to a statistical evaluation of the initiation energy required for PETN. For the most part, powdered expls were used; however, a limited effort also was expended on large single crystals. The use of a light guide as a means of transporting energy was also examined. It was established that although a highly sensitive mixt can be detonated thru a light guide, the attenuation of the radiation is too great to make this method practical for secondary expls

D. Shock.

Shock initiation of expls will be treated in detail in a subsequent article in this Vol. However, many of the exptl investigations of shock initiation involve RDX and these will be presented below

Price and Liddiard, in their extensive study (Ref 17) of shock initiation in the "gap test" (see Vol 6, G13-R) give the following input shock press amplitudes for 50% thresholds (½ the tests were detons and ½ the tests were failures) for RDX in their SSGT (small scale gap test) set-up (5.1mm ID test expl columns, 38.1mm long, confined in 25.4mm OD brass tubes):

ρ_0 (g/cc)	% TMD	50% input shock pressure* (kbar)
1.56	86.5	9.8
1.63	90.5	11.2
1.72	95.3	13.8
1.73	96.0	17.1

*at the test expl interface of the inert gap barrier

The writer (Ref 37) used an instrumented gap test, in which 12.7 x 12.7mm cylindrical test samples were unconfined, to obtain Hugoniot data, shock sensitivity and build-up distances for RDX and other expls. For RDX the following results were obtained:

ρ_0 (g/cc)	Av particle size (μ)	Temp ($^{\circ}$ C)	50% threshold* (kbar)	Run-up distance** to detonation (mm)
1.64	17	25	15.2	7.6
1.58	17	180	7.8	9.3
1.54	5	25	15.0	9.5
1.54	18	25	8.8	6.5
1.54	60	25	9.0	12.5

*in the RDX at the barrier/RDX interface
**at the 50% threshold

Note the increase in shock sensitivity with increased ambient temp and decreasing ρ_0 . Further note the greater shock sensitivity of the coarser RDX vis-a-vis the finest RDX. It is difficult to compare these data with those of Ref 17 because the latter were obtained in a confined test geometry. Correction for the effect of confinement and conversion of the Ref 17 thresholds to input pressure in the RDX (rather than the given exit pressures in the barrier) are expected to bring both sets of data into better agreement

Scott (Ref 39) also examined the effect of particle size on shock sensitivity. He used a test arrangement similar to the SSGT of Ref 17. His results are presented in the form of output energy (dent in witness plate) vs input shock (exit pressures in the barrier) curves. His curve for RDX, Fig 4, agrees with the writer's observation that coarse RDX is easier to initiate by shock than fine RDX

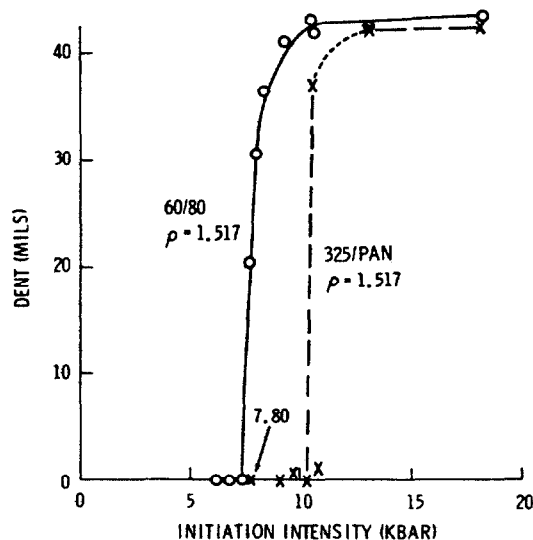

Fig 4 Output of RDX particle sizes (60/80 and 325/pan)

Ilyukhin & Pokhil (Ref 5) used plane wave shocks thru a brass barrier to initiate RDX. For RDX of ~ 0.1 mm particle size at 1.74g/cc the threshold shock was found to be 15kbar

A recent study by Dremin & Shvedov (Ref 99) examined the effect of gas additives on the shock initiation of RDX and TNT lightly pressed charges of $\rho_0 \sim 1$ g/cc. The nature of the gas or its partial press had no effect. They did find an interesting effect in all their observations, namely a break in the plot of barrier/expl interface velocity (u) vs time. Their summary plot for RDX is shown in Fig 5

At high input pressures (to the left of t_c in Fig 5) the expl behaves as if it were homogeneous and there is no particle size effect. At input pressures below 50kbar, reaction occurs at individual hot spots. The strong effect of particle size in this region is said to be due to the action of hot gases in the pores of the expl

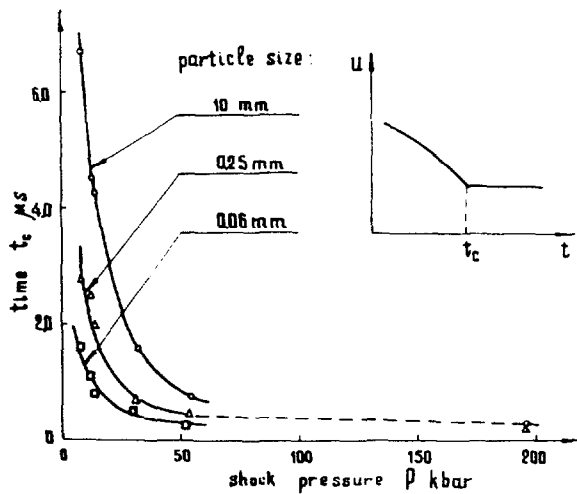

Fig 5

Longueville et al (Ref 100) used flyer plates to study the shock sensitivity of RDX (and other expls) as a function of shock amplitude and shock duration. Their results for RDX are shown in Fig 6

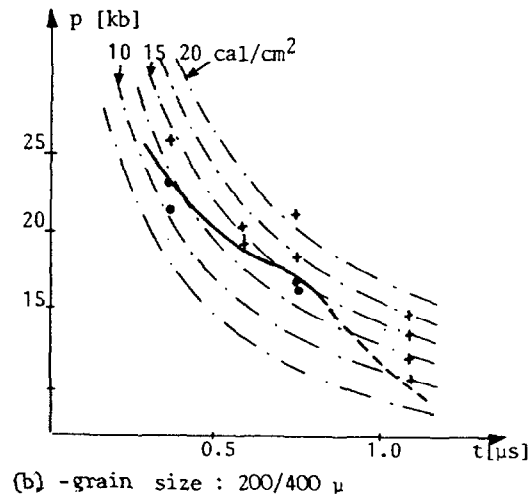
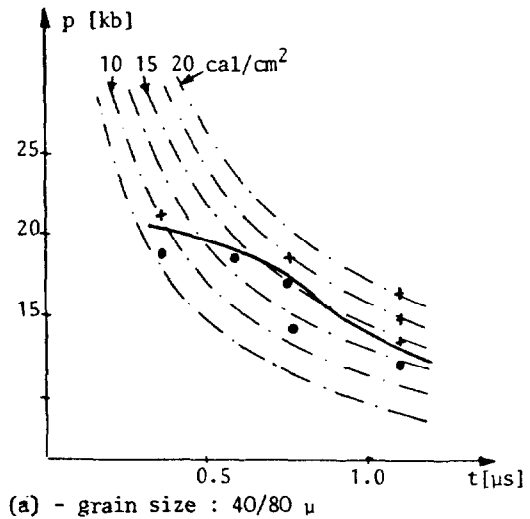

Fig 6 Sensitivity of Granular RDX

+ detonation • no detonation

The broken curves represent profiles of equal fluence, eg 10cal/cm², etc. The solid curves are drawn thru the exptl data and separate the region of detons and failures. Note that the effect of shock duration for the finer RDX is rather mild and becomes somewhat more pronounced for the coarser RDX

Aleksandrov et al (Ref 19) used the electro-magnetic method to obtain what they term reaction times τ as a function of input press P. For RDX of 1.8mm particle size at 1.0g/cc they obtained the following:

P (kbar)	τ (microsec)
44.3	0.82
59.8	0.80
84.3	0.75
95.0	0.67

At face value P appears to have very little influence on τ

Voskoboinikov et al (Refs 21 & 23) examined the shock initiation behavior of single crystal RDX. The threshold press was detd to be 170kbar, and the expln delay at that press was 1.0 microsec. A Grueneisen-type EOS was used to calculate the shock temp at the threshold to be 770°K

An interesting study by Schulz et al (Ref 78) used laser light in conjunction with a fast streak camera and Raman spectroscopy to follow the decompn of single crystal RDX at 150kbar input press. Four regions were distinguished: (1) induction period with no light emission; (2) continuous light emission, comparable to a blackbody, of 500–600 nanosec duration; (3) line spectra characteristic of the expl with a max at 700 nanosec; and (4) line spectra characteristic of the impurities present arising about 1200 nanosec after shock input

The main lines in (3) are associated with CN, N₂, NO₂ and CH. However NO₂ is definitely a primary decompn product which disappears via reaction with fuels to generate heat and light

Gas detonations were used to initiate low d pressings of RDX and other expls (Ref 19a). The initial gas pressure required to initiate RDX at 0.9g/cc, within 1 microsec, was 26 atm. At lower gas pressures the induction times increased, and at still lower pressures no detons were obtained. It was concluded that unconfined external gas detons will not initiate deton in a pile of RDX

Two studies describe the prepn of shock-sensitive RDX: A form of RDX with a shock sensitivity comparable with that of PETN has been produced by sublimation. However, the material is as insensitive to heat, impact, friction and static discharge as are the normal forms of RDX, and it has a similar storage life (Ref 47)

A British patent (Ref 36) claims that heating RDX for 6–48 hours at 140–80°C produces

imperfections which make it more shock-sensitive but cause no essential increase in its impact sensitivity

VI. Combustion and DDT.

Combustion of RDX was mainly studied by the Russians and is associated with the names of Belyaev and Andreev. There are also a number of important Russian investigations of DDT, although recently some definitive studies have been made at NOL and in France

A. Combustion Studies.

Belyaev et al (Ref 6a) detd press levels at which deton occurs during combustion of pressed charges of RDX, PETN and TNT. The test samples, in the form of rods 10mm in diam and of various degrees of porosity, were burned in a manometric bomb. Press vs time was recorded during burning. A sharp break in the curve occurs when combustion first penetrates the pores of the expl, but stable combustion occurs when the expl charge is protected from the burning surface by a fused zone. If the porosity, η , of the expl is greater than the thickness of the fused zone, burning can penetrate into the charge. For TNT, PETN and RDX with $\eta = 0.1$, this occurs at pressures of approx 800, 300 and 130 bars, respectively. For expls which do not melt, the gaseous reaction zone at the burning surface acts similarly to a fused zone

Andreev & Gorbunov (Ref 7a) also studied the stable and unstable combustion of RDX. They find that under otherwise comparable conditions charges of lower packing d burn less stably than higher d charges. This is illustrated in Fig 7, where P is the measured press at time τ . The average rate of combustion for curve 1 was 3.0cm/sec (at 150 atm). In general, fine grained RDX burns more stably than coarse grained RDX (see below)

Andreev & Chuiko (Ref 7) found that the combustion of granular RDX (and other secondary expls) is no different from that of cast or single crystal expls at low ambient pressures. Above a certain ambient press the combustion of granular expls becomes acceleratory, and its rate can be 10 to 100 times greater than that of "normal burning". This threshold press increase (with increase in packing d and decrease in particle size for many secondary expls, including RDX)

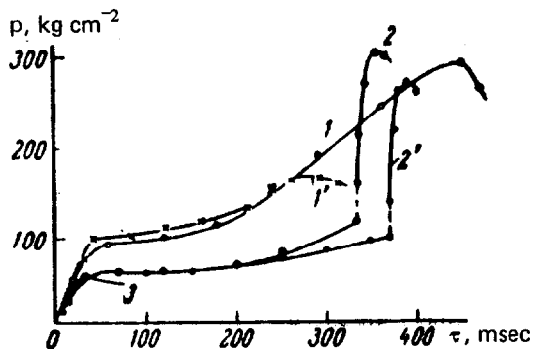

Fig 7 Effect of charge density on the stability of the normal burning of RDX. Relative charge d : 1) 0.98; 2) 0.93; specific resistance in arbitrary units: 2) 110; wt of charge: 1') 1.00g; 1) 2.00g; 2) and 2') 1.50g; 3) p - τ curve for the burning of the igniter alone (1.0g). The broken line represents the transition of the burning to detonation accompanied by fragmentation of the beaker

shows that a plot of $\log 1/\eta$ (where η is the gas permeability of the charge) is a linear function of charge d . Permeability increases as particle size increases

Similar results were obtained by Taylor (Ref 5b) who found that RDX of varying particle size burned in paper tubes had the following burning rates at 52 atm:

Particle size (microns)	Packing density (g/cc)	Burning rate (g/cm ² sec)
~5	1.07	1.66
~200	1.16	33.3

The following eqn for the stable burning of RDX is given in Ref 67c: $U_m = BP^n$ where U_m is the mass burning rate, P the ambient press and B and n are constants. For $1 \leq P \leq 1000$ atm, $B = 65.7 \times 10^{-3}$ g/cm²sec and $n = 0.835$. At 300 atm, $U_m = 7.6$ g/cm²sec

A recent study of the deflagration of RDX (Ref 107) presents the following model for the deflagration process: (1) partial decompn in the liq phase; (2) vaporization and gas phase decompn; (3) oxidation of products (particularly HCHO) by NO_2 . As system press increases, (1) and (3) become progressively more prominent. Although the reacting liq layer at high pressures is thin, its heat feedback into the still unreacted material increases

Temp and relative intensities of the combustion products detected as a function of height along an RDX flame are shown in Fig 8 (Ref 67d). Intense radiation from the OH radical is observed immediately next to the combustion surface of the RDX sample. The intensity of the radiation attains its max value at a distance of 0.1mm and varies slowly with further increase in height along the flame. Luminescence of the radicals C_2 , CN, and CH appears at a distance of 0.1–0.2mm from the combustion surface and increases markedly as the zone of max temp in the flame is approached

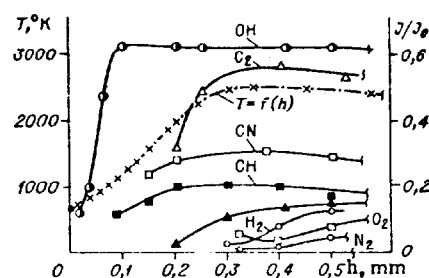

Fig 8 Distribution of temperature and relative intensities of OH, C_2 , CN, CH, H_2 , O_2 , and N_2 with height along an RDX flame, $p = 30$ atm

Dubnov et al (Ref 61) examined the mechanism of initiation and the development of combustion and deton of solid RDX and PETN subjected to shock waves. Effect of the compn of surrounding gas, of the deton velocity of the initiating shock wave and of the deton press and temp of the reflected shock wave on the combustion of the expl was studied. Effects of the d of the expl and of its surface roughness were also taken into account

B. DDT.

Modern studies (Refs 18, 28, 72, 73, 74 & 106) have stressed the importance of a *convective flame front* in establishing DDT in granular expls. A convective flame front is an ignition wave which is propagated by the passage of hot combustion gases thru the pores of the charge. The hot gases are forced into the pores because of confinement at the igniter end of the container. However, penetration of the gases into the charge does not result immediately in the formation of a convective flame front. The gases heat the pore walls and are consequently

cooled themselves. It is this *continuous* flow of gases which raises the temp of the pore walls until ignition in the pores occurs and produces what is now the head of the convective front

Belyaev et al (Ref 18) give critical pressures above which normal conductive (surface) burning changes into convective burning. For RDX at a d of 50kg/m^3 (?) (charge diam not given) the critical press decreased from about 200 bars to about 100 bars as the porosity = $1 - \rho / \text{TMD}$ increased from about 0.07 to 0.125. It is claimed that these pressures are much lower than those for TNT, PETN, etc because RDX is higher melting than these other expls

Obmenin et al (Ref 28) find an "LVD" regime in 500 micron RDX at a porosity of 0.02. In brass tubes the propagation rate is 700m/sec and in steel tubes it is 1600m/sec. These LVD values are much lower than those for PETN (see Vol 8, P113-R to P114-L)

A definitive study of convective burning and DDT has been made by Bernecker & Price (Refs 72, 73, 74 & 106). Their investigation of DDT in 91/9 RDX/wax was described in some detail in Sect VII of the article on *Propellants, Solid* in Vol 8 (P453-L to P456-L). Consequently below we only show their schematic representation for DDT for 91/9 RDX/wax (Fig 9)

More recently these authors extended their study to include 94/6 RDX/wax over the range of 70% to 97% TMD (Ref 106). DDT trends are similar to those of the 91/9 RDX/wax series but this mixt has a much shorter time range corresponding to its increased sensitivity. Data are also given for one waxed RDX and two waxed HMX series at fixed percent porosity (100 - % TMD). All mixts followed the physical model proposed for DDT of 91/9 RDX/wax. However, the series run at fixed % TMD and varying wax content showed strong correlations between the relative time to deton and the predetonation column length. No similar correlation appears at fixed compn and varying porosity

Afonina et al (Ref 35) studied DDT of RDX (and other expls) by using hot wire ignition on expls contd in sealed steel tubes that could withstand 5-12kbar of internal press. The RDX d was 1 to 1.2g/cc. (No other data in CA; original unavailable to us)

Calzia & Carabin (Ref 38) and Calzia (Ref 60) studied DDT in RDX using wire-probe and

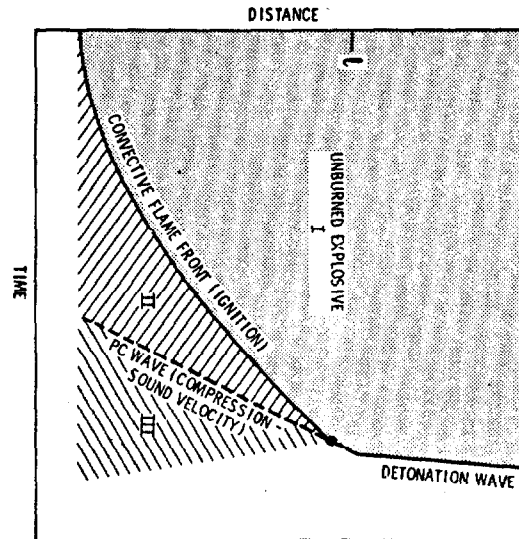

Fig 9 Proposed DDT mechanism for 91/9 RDX/wax granular charge. Regions: I. Undisturbed granular bed at initial compaction. II. Explosive burning to give linear increase of pressure with time; compaction occurs in most porous charges. III. Accelerated burning and pressure buildup to form precursor shock

streak camera techniques. In the first paper it was shown that deton begins ahead of the deflagration. The initial deton velocity exceeds stable D for the conditions of the expt. A detonation wave into the unreacted or partially reacted expl was also observed

In Ref 60 as in Ref 38 the container tubes had a small orifice (2.5-21mm in tubes 40mm ID). Orifice dimensions appear to have little effect on DDT. At constant $\rho = 1.15\text{g/cc}$, ℓ , the length of the pre-detonation zone increased from $4.5 \pm 1\text{cm}$ to $9 \pm 2\text{cm}$ as particle size decreased from 170 to 13 microns, eg, $\ell = 7 \pm 1\text{cm}$ at 45 microns and $\ell = 5.5 \pm 1\text{cm}$ at 120 microns. For constant particle size the effect of ρ was as follows:

ρ (g/cc)	ℓ (cm)
1.14	6 ± 1
1.19	6 ± 1
1.24	3 ± 0.5
1.33	6 ± 1
1.40	2 ± 0.5
1.50	3 ± 0.5

VII. Decomposition and Kinetics

Most of the thermal decomn studies of RDX were made over a temp range in which the RDX is initially in the solid state (except Ref 26a). Many of these studies were done by Batten in Australia and Cosgrove & Owen in England. The mechanism of these complex decomps is still largely in doubt. Furthermore, published values for the overall activation energy are highly discordant

Since the decomn of molten RDX is expected to be less complex than that of the solid it will be described first. Rauch & Fanelli (Ref 26a) examined molten RDX decomn over the temp range of 207–27°C by analyzing decomn products and the amt of RDX remaining as a function of heating time. They conclude that

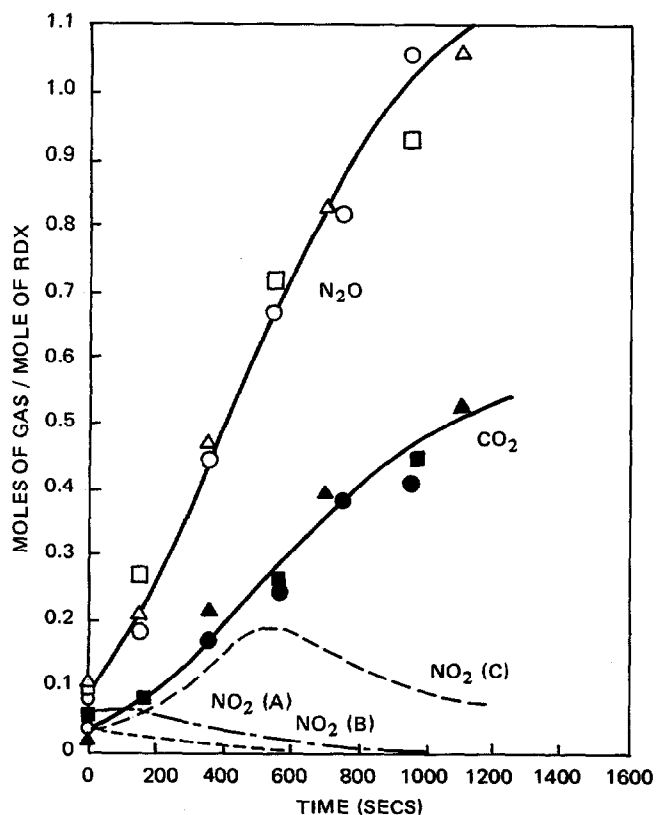

Fig 10 Concentration-time profiles of N_2O , CO_2 , and NO_2 for three reactor volumes. N_2O and CO_2 curves: o and •, 26ml; Δ and \blacktriangle , 100ml; \square and \blacksquare , 300ml. NO_2 curves: A, 26ml; B, 100ml; C, 300ml. Initial weight of RDX, 40mg. (See Fig 11 for data points of NO_2)

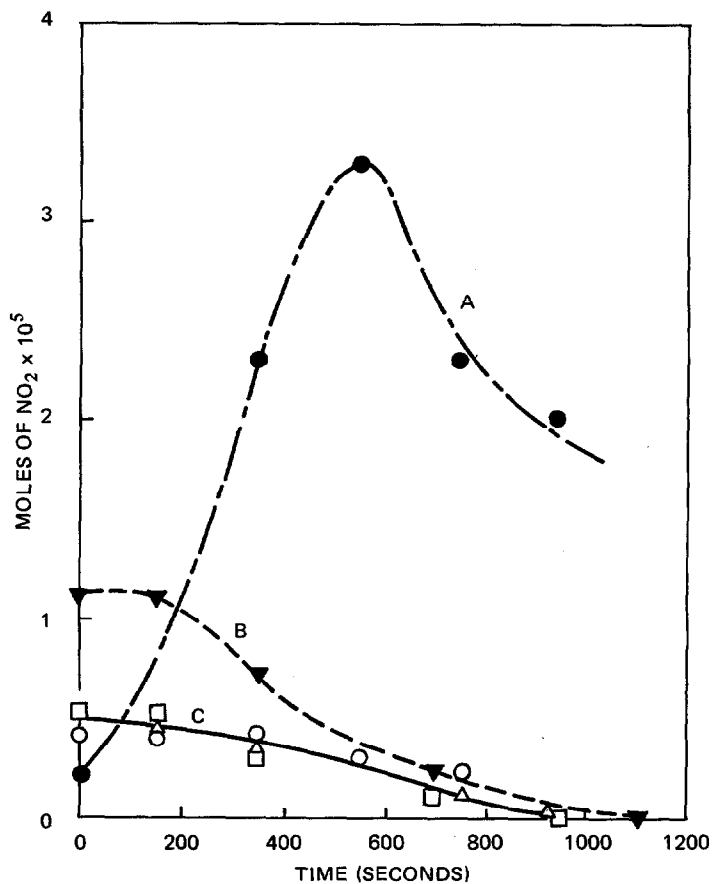

Fig 11 Concentration-time profiles of NO_2 for various initial weights of RDX and reactor volumes. Initial weights and volumes: A, 300ml, 40mg; B, 100ml, 40mg; C, 26ml, 12.5mg (o), 26mg (Δ), 41.0mg (\square)

the decomn is first order. The principal gaseous products are N_2O , NO , CH_2O , CO , CO_2 , H_2O , and HCN

Figure 10 presents the concn-time profiles at 212°C of three products for a constant initial wt of RDX in reactors of different volume. Figure 11 illustrates the data for the NO_2 in Fig 10 on an absolute basis and on an expanded ordinate scale. The profiles of the other gaseous products are not shown for the sake of clarity, but all follow the same general pattern as evidenced by N_2O and CO_2

Figs 10 and 11 show that NO_2 formation depends on reaction vessel volume, whereas CO_2 , N_2O (and other products) are formed

Table 3
Kinetic Data for the
Decomposition of RDX at 212°

Initial weight of RDX, mg	Reaction volume, ml	Rate constant, sec ⁻¹ x 10 ³
40.0	300	2.2 ± 0.2
40.0	100	2.1 ± 0.1
40.0	26	1.9 ± 0.2
26.0	26	1.7 ± 0.2
12.5	26	2.0 ± 0.1

independently of vessel volume. Kinetic data for the 212°C decompn are shown in Table 3

The results of Figs 10 & 11 and Table 3 are strong indications of a concurrent liq and gas phase reaction. Because the amt of RDX in the gas phase will be a function of the vapor press at that temp, on a per initial mole basis, products arising from a liq phase reaction should be independent of the initial weight and increase proportionately with reactor volume. N₂O and CO₂ clearly follow the former pattern and NO₂ the latter. The rate constants of Table 3 calcd by changes in the total amt of RDX are seen to be virtually unchanged within exptl error under the various conditions of initial wt and reactor volume. This invariance of the rate constant indicates that the gas phase decompn represents only a relatively small fraction of the total degradation process

It is obvious that NO₂ disappears via secondary reactions but the course of this disappearance is difficult to analyze because the vapor press of RDX probably decreases during the course of reaction due to the formation of nonvolatile products. Thus the direct dependence of the total amt of NO₂ produced on the reactor volume is not easily demonstrated

The kinetic parameters for the overall decompn are given as E = 48.7kcal/mole and Z = 1.9 x 10¹⁹sec⁻¹

Batten (Refs 30, 31, 32, 47 & 58) studied the decompn of solid RDX over the range of 170–97°C. In agreement with Ref 26a, the major gaseous products found were N₂O, H₂O, N₂, HCHO, CO₂, CO and NO and minor amts of NO₂ & HCN (Ref 32). A non-volatile residue (NVR) was identified as N-hydroxymethylformamide, HCON(OH)CH₃. Added NVR or

HCHO enhances initial decompn rate, while added NO₂ inhibits and NO has no effect (Refs 32 & 46). It is suggested that the decompn proceeds as follows:

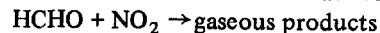
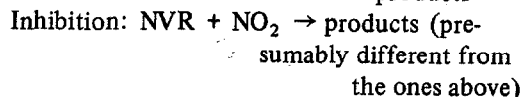
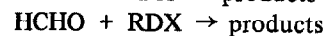
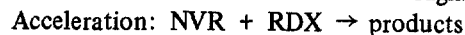
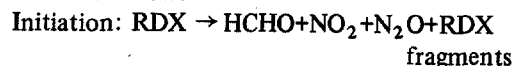

Oxygen has a mild inhibiting effect, probably because it reacts with NO to form NO₂. It is claimed that the N–N and C–N bond split in the RDX molecule account for all the observed products (Ref 46)

Sample geometry and whether the sample is spread or unspread affect decompn rates (Refs 30, 46 & 58), but grinding the sample or using sublimed RDX (to eliminate occluded solvents or gases) did not change the rate (Ref 58). The decompn appears to have a “memory effect”, ie, if heating is interrupted and the sample is cooled and then heating is resumed, the sample behaves as though there was no interruption in the heating (Ref 58). Pre-irradiation with uv light enhances subsequent thermal decompn (Ref 58)

It is claimed (Ref 31) that the above effects suggest that gaseous decompn products enhance the rate of decompn of solid RDX. In spread samples the activation energy is given as 63 kcal/mole (?) over the entire decompn range, whereas for unspread samples the activation energies for induction, acceleration and max rate regimes are claimed to be 49, 43 & 62 kcal/mole, respectively (Ref 30)

Investigators at ERDE (Refs 70, 71 & 112) reached somewhat different conclusions in their studies of the decompn of RDX below its melting point than those reached by Batten & co-workers. The two sets of studies agree that the initial amt of RDX has no effect on the decompn rate and that HCHO & hydroxymethylformamide increases the rate of decompn. The ERDE studies (Ref 71) also show (Table 4) that methylenediformamide or 1,3,5-Trinitrobenzene increase the rate of decompn

Table 4
The Effect of (a) Formaldehyde, (b) Hydroxymethyl formamide, (c) Methylene Difformamide
and (d) 1,3,5-Trinitrobenzene^a

Time mins	Additions mM	RDX reacted mM	Products								
			N ₂	N ₂ O	NO	CO ₂	CO	CH ₂ O	HCOOH	NH ₃	NO ₃
31		0.042	0.035	0.053	0.036	0.021	0.008	0.048	0.039	0.035	0.010
60		0.105	0.100	0.100	0.069	0.056	0.046	0.110	0.101	0.071	0.019
(a) Formaldehyde											
20	0.076	0.032	0.032	0.029	0.037	0.020	0.025	0.092	0.041	0.036	—
40	0.080	0.083	0.062	0.095	0.079	0.050	0.065	0.128	0.056	0.058	—
60	0.070	0.153	0.154	0.165	0.123	0.095	0.111	0.174	0.092	0.093	—
20	0.370	0.036	—	—	—	—	—	0.301	0.039	0.025	0.012
40	0.360	0.101	0.081	0.103	0.087	0.063	0.087	0.337	0.069	0.063	—
60	0.380	0.180	0.157	0.210	0.138	0.115	0.131	0.417	0.096	0.094	0.032
(b) Hydroxymethyl formamide											
21	0.180	0.110	0.115	0.139	0.065	0.068	0.037	0.284	0.185	0.200	0.018
30	0.145	0.140	0.158	0.169	0.081	0.078	0.041	0.253	0.162	0.149	—
40	0.168	0.204	0.210	0.262	0.109	0.101	0.095	0.358	0.226	0.244	0.025
(c) Methylene difformamide											
20½	0.115	0.172	—	—	—	—	—	0.262	0.242	0.281	0.027
30½	0.114	0.231	0.239	0.307	0.126	0.119	0.091	0.332	0.250	0.316	—
40	0.115	0.363	0.400	0.500	0.135	0.202	0.156	0.430	0.325	0.320	0.038
(d) 1,3,5-Trinitrobenzene											
30	0.050	0.140	0.135	0.154	0.100	0.058	0.045	0.088	0.052	0.057	—

^aTemperature 195°C. Initial RDX 0.900mM. Volume at reaction flask 150ml

Note that in the initial stages of decompn the effect of added HCHO is relatively small. The rate is directly proportional to the volume of the reaction vessel and is decreased by N₂ press and that of other gases such as N₂O, CO and CO₂ (Ref 70). Addition of NH₃ or MeNH₂ increases the decompn rate. Hydroxymethylformamide is claimed to react with RDX to form 2,3',4,5',6-pentanitrophenyl (Ref 112)

Cosgrove & Owen (Ref 70) propose that initial decompn occurs in the vapor phase. This explains the enhancing effect of reaction vessel volume and inhibiting effect of inert gas press which slows down diffusion of RDX vapor from RDX crystal surfaces, and may explain some of

the strange effects of spread vs unspread samples observed by Batten. The proposed scheme for the gas phase reactions is:

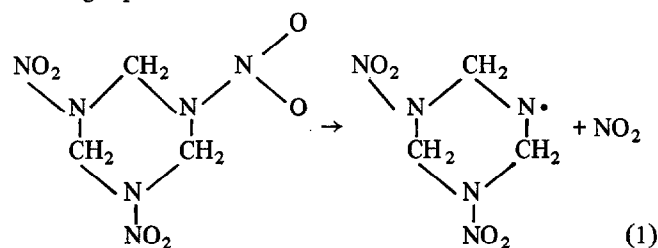

Evidence for this step is provided in Fig 11 which shows rapid production of NO₂ in the early phases of decompn of molten RDX, but is postulated to occur in the gas phase (Ref 26a)

The ring is then claimed to open and break up by the following (rather questionable) steps:

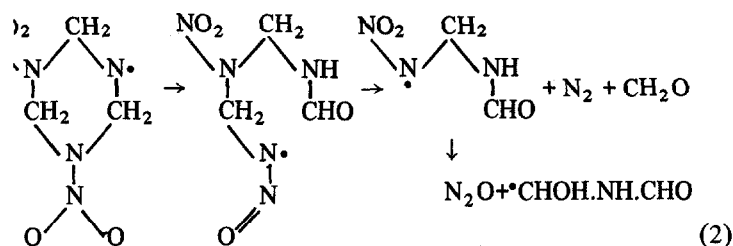

The $\cdot\text{CHOHNHCHO}$ radical (regardless of its route of origin) can abstract a proton to form hydroxymethylformamide or dimerize. The former is unstable at the temps used in the study and decomps according to:

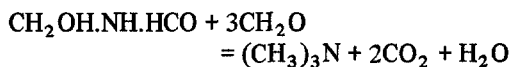

The NO_2 formed in the initial step is consumed largely in a reaction such as

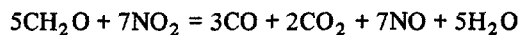

Cosgrove and Owen (Ref 71) believe that the rate increase produced by hydroxymethylformamide, methylenediformamide or Trinitrobenzene is primarily due to their acting as solvents for RDX, and is an accelerated decompn of the dissolved RDX. The nature of this acceleration is still in doubt (indeed there is doubt that the acceleration is due to soln of the RDX by the additives or direct reaction between RDX and the additives). They suggest the following equil reaction for the initial step of the decompn of RDX in soln:

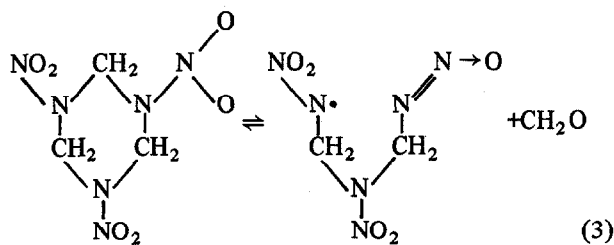

This writer finds this suggestion rather strange. First, the breaking of a C-N bond (or even worse of two C-N bonds) requires about 60kcal, whereas the breaking of a N-N bond (step 1) requires only 46kcal (Ref 120). It also seems that addition of HCHO should retard decompn

in the later stages of reaction [after step (3) is presumably operative because of the formation of hydroxymethylformamide or other product that dissolves RDX] which is just the opposite effect of that observed (see Table 4). Indeed it might be suggested that step (1) is an equil reaction and that added HCHO reacts with NO_2 and thus prevent the reverse reaction of step (1). Furthermore, curves B and C of Fig 11 are strongly suggestive of an equil concn of NO_2 , at least in the early stages of decompn

The rate enhancement (whatever its mechanism) by hydroxymethylformamide and other NVR certainly provides an explanation for the "memory" and pre-irradiation effects observed by Batten

However, there could also be an alternate rationale. Belyaeva et al (Ref 49) suggest that the decompn of crystalline RDX begins at crystal defects already present or temp induced (possibly also induced by pre-irradiation). Decompn leads to deformation of the crystal lattice and more defects. If decompn products cannot diffuse, they crack the crystal which leads to a suddenly increased evolution of gas. This model can explain the "memory" and pre-irradiation effects, but is incapable of explaining most of the observations of the Australian and English studies

The decompn of RDX was also studied by Kinard (Ref 57). Unfortunately only an abstract of this master's thesis was available and it provides little information

In an interesting study, Mel'nikov & Nikitin (Ref 51) subjected RDX to electrical sparks (rectangular pulses of about 1000 amps and 3 microseconds duration). Under these conditions, RDX expld in times of the order of one microsec. It is claimed that the activation energy for this process is 52.4kcal/mole and $QZ = 3.6 \times 10^{18}$ kcal/g sec, where Z is the Arrhenius frequency factor and Q is the heat of expln

Hall (Ref 41), using differential scanning calorimetry (DSC), claims an activation energy of 45.2kcal/mole for decompn in the range of 483-534°K, and a heat of reaction of 0.61 kcal/g

Kishore (Ref 111) gives the heat of decompn of RDX in the range of 480-500°K as ~ 0.54 kcal/g and an overall activation energy of 41 ± 2 kcal/mole. He claims that reaction order is

0.6 (?)

Rogers (Ref 74) also used DSC to determine $E = 47.1 \text{ kcal/mole}$ and $Z = 2.0 \times 10^{18} \text{ sec}^{-1}$. In an earlier study (Ref 5a), Rogers found that the time to expln (and obviously time for reaction) of RDX is considerably reduced by the addition of urea and less so by the addition of rosin. His results are shown in Fig 12

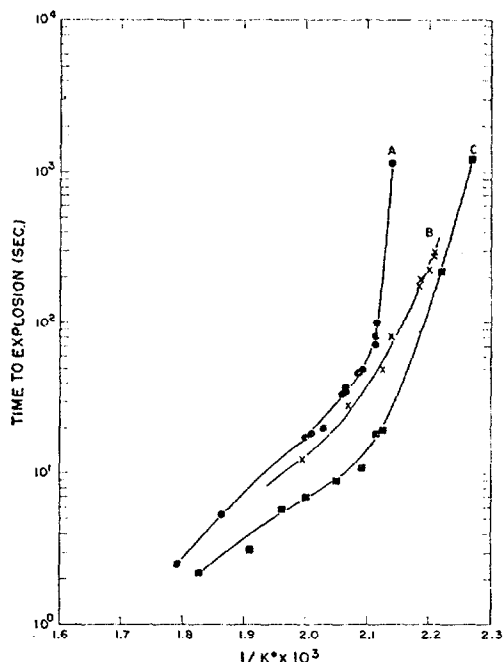

Fig 12 The systems RDX—rosin and RDX—urea
A. Production grade RDX
B. RDX with rosin, 50% by weight
C. RDX with urea, 20% by weight

Harris (Ref 91), using a differential thermal analysis (DTA) technique, gives an activation energy of 34000 cal/mole for RDX and an "autoignition" temp (apparently the ignition temp at the minimum rate of heating) of 197°C . The activation energies obtained by this method appear to be low

VIII. Analytical Methods.

Modern analytical methods for RDX tend to stress instrumental techniques such as mass spectrometry, chromatography and polarography in lieu of the traditional "wet-chemistry" methods. Also there is emphasis on micro methods

A chemical ionization mass spectrometry

method of analyzing RDX uses w as the reagent gas. It is claimed that this method is more effective than electron impact mass spectrometry or chemical ionization mass spectrometry using methane, ethane, or isobutane reagent gases (Ref 79a)

Gillis et al (Ref 79), using H_2 reagent gas in a chemical ionization mass spectrometry system, suggest that the RDX mass spectrum can be rationalized by the following scheme:

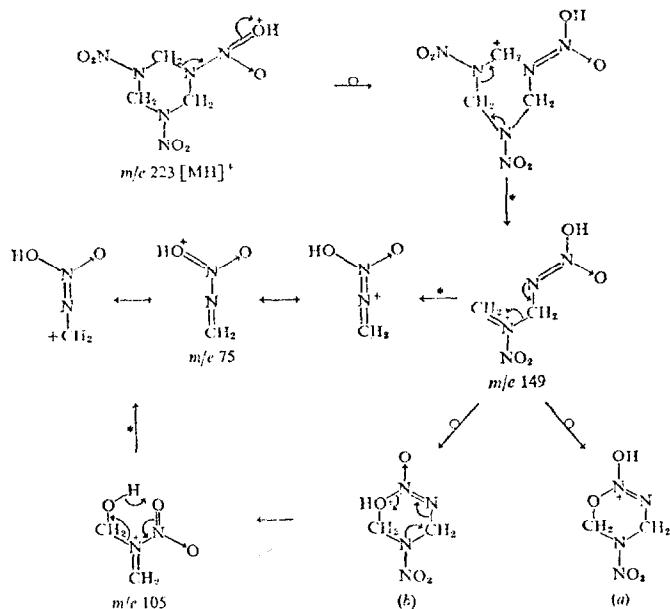

Rationalization of the $\text{CI}(\text{H}_2)$ Spectrum of 1,3,5-trinitro-1,3,5-triazacyclohexane (RDX)

A liq chromatographic method is claimed to detect as low as 0.01% RDX (Ref 89), and a gas chromatographic technique using polar liq columns is claimed to have an error limit of 6–8% and a detection limit (with a flame ionization detector) of 0.3 microgram (Ref 85)

A new polarographic analytical procedure that should prove useful in the direct analysis of RDX and HMX in admixts is described in Ref 88. This single-sweep technique is rapid and sensitive to about 50 parts-per-billion of either RDX or HMX alone or in admixt in natural w effluent. The method can also be used to analyze for HMX as an impurity in manufd RDX or for RDX that may be present in manufd HMX

Amas et al (Ref 27) have improved the conventional spot test for RDX to reduce interference by sugars and aldehydes. The prescrip-

tion for the improved test is as follows (I = RDX): Add 200mgs thymol-blue and 6 drops sulfuric acid to mg amts of sample, warm 5 mins at 100° and add 5–10ml EtOH. A rich blue soln confirmed I. Sugars and aldehydes gave a brown color and cyclotetramethylenetetranitramine (II) gave a pale blue-green color. I can be distinguished further from II by repeating the test at 150° so that I and II give blue and olive colors, respectively. I was the only compd commonly found in expl formulations which gave a blue color in the modified test

A semimicro spectrophotometric method is proposed for the detn of RDX and HMX whereby up to 1 mg of these compds is hydrolyzed by evaporating to dryness with 5ml of NaOH soln (2.5%), the salts are dissolved in 10 to 3 sulfuric acid, a soln of ferrous sulfate soln in 10 to 3 sulfuric acid is added, and the pink color is determined. The method is recommended for the detn of RDX and HMX in compns contg less than 20% of these compds (Ref 22)

An expl detection spray system has been developed which will detect expl residues on the exterior of letter and package bombs. The detection is thru the formation of colored reaction products using select spray reagents. Reagents were screened for shelf life and toxicity. The wavelength of absorbance and absorptivity of the reagent expl complex was detd. The spray reagent of choice capable of detecting 0.4 microgram of TNT is prepd by adding 5 grams of 1,3-diphenylacetone and 5ml of 20% tetracethylammonium hydroxide in methanol to 100ml of ethanol. RDX and Nitrate esters are detected at the 0.4 microgram level by spraying the substrate with a suspension of 10g of Zn dust in benzene, followed by a soln of 0.35g of procaine and 0.35g N,N-dimethyl-1-naphthylamine in 100ml of a 50/50 acetic acid/distd w mixt (Ref 108)

IX. Waste Disposal.

Current emphasis on ecological controls of the environment has prompted a number of studies of waste w disposal in RDX manuf (as well as in the manuf of other expls). The various approaches tried have been flocculation, microbiological and chemical degradation, filtration thru activated sludge, photolysis, and photolysis

with ozonation

A recent summary of the state of the art (Ref 95) has surveyed the military expls and proplnt manuf industry, covering both "GOGO" and "GOCO" facilities. Sources of wastewater, volumes, and pollutant constituents have been reported where such data existed. Treatment technology currently in use at the various installations has been described, including effectiveness of pollutant removal and secondary (air and solid) waste generation. Systems under development at these military installations have also been examined and evaluated in light of available information. The report consists of three volumes. Vol I presents general conclusions and recommendation and describes the industry's manuf operations. Vol II presents the bulk of the data concerning the wastewaters and the treatment systems now in place. Vol III reviews and summarizes data from the first two volumes and describes and evaluates the new treatment processes under development at this time

A study (Ref 116) was undertaken to determine the compatibility of polymer flocculating agents with expls present in waste waters at Army Ammunition Plants. These agents are used effectively for the removal of the suspended matter in aqueous media. As such, they could serve to remove colloidal suspensions of expls which clog the charcoal filters that are used to adsorb solubilized expls from waste water effluents. Before these flocculating agents can be accepted as standard items for the pre-treatment of waste water effluents at expls processing plants, their compatibility with expls in the dry state must be established. Of the flocculating agents, WT2600, CAT-FLOC, CAT-FLOC-T, and E-653, tested for their compatibility with RDX, TNT and Comp B, only E-653 was found to be acceptable. A possible mechanism is proposed for the reactivity of the polymer flocculating agents with expls

RDX had previously resisted degradation by microorganisms, until a microbial system containing a purple photosynthetic bacteria was found to degrade RDX. The hypothesis is advanced that the RDX molecule is not actually metabolized, but is reduced and modified as a result of the active electron transfer brought about by the anaerobic photosynthetic activity

of the organisms. This concept of indirect change may be applicable to other microbial processes in which similarly recalcitrant molecules could be modified and degraded (Ref 59)

RDX is chemically degraded by interaction with strongly basic ion-exchange resins (Ref 117). Lab and pilot scale tests with such a resin show no loss of efficiency after eight regeneration cycles. One cubic foot of resin was found capable of degrading and removing 99% of the RDX contd in 1300 gals of tap w before regeneration was required

A study was made at the Holston Army Ammunition Plant (HAAP) to determine the toxicity of five wastewaters associated with a pilot biological treatment plant. Manufg wastewaters from both Area A and Area B were mixed in a ratio of 1:9 by volume, respectively. This mixt was then treated by two biological systems — the 3A system which consisted of an activated sludge chamber, and the 6A system which contd both a trickling filter and an activated sludge chamber. Work performed at HAAP included on-site 96-hour static acute LC50 bio-assay tests using fathead minnows. Solns tested were Area A wastes, Area B wastes, the A + B mixt, the 3A system effluent, and the 6A system effluent. Quant analyses of RDX, HMX and TNT in the test waters were also conducted with each test. The overall results of the on-site bioassay tests indicate that biological treatment, either activated sludge or the combination trickling-filter-activated sludge does reduce the toxicity of the HAAP manufg wastewaters (Ref 115)

A flow apparatus for detroying 98% of the w-dissolved RDX at flow rates of 2500ℓ/min is described in Ref 114. The photolysis products include nitrogen gas, nitrous oxide gas, nitrate and nitrite ions, formaldehyde and ammonia. One intermediate product has been identified as 1-nitroso-3,5-dinitro-1,3,5-triazacyclohexane. The primary photochemical steps involved in the photolysis are postulated

Four bench-scale UV systems used in the treatment of aq expl solns have been investigated (Ref 113). Studies relating the effects of acet and H₂O₂ in the treatment are reviewed. Under given conditions, UV light (254nm) in conjunction with small concns of H₂O₂ results in the elimination of RDX and other expls from

their aq solns. No significant concns of any related conversion products were detected in the one hour photolysates

Jain (Ref 96) found that ozonization of RDX dissolved in w is enhanced by concurrent exposure to UV radiation. It is claimed that a flow system based on this combined photolysis-ozonolysis can provide a cost-effective method of RDX removal from munition industry waste waters

Smetana et al (Ref 118) used a scheme previously developed for eliminating TNT from "pink water" to show that combined photolysis-ozonolysis effectively degrades RDX in aq solns to gaseous products. The photolytically active region is in the UV at 254, 300 and 350nm wave lengths

X. Toxicity.

Several RDX toxicity studies have been completed in recent years. Most of these studied animal behavior and reactions when exposed to controlled amts of RDX

Ref 67a presents an annotated bibliography on the toxicity of RDX. It contains 20 refs thru 1972

Studies on toxicity of RDX on monkeys, dogs and rats were conducted at Litton Biogenetics, Inc (Refs 75, 76 & 93). The results for monkeys and dogs are summarized below:

Forty-two rhesus monkeys were exposed to daily doses of 10, 1, and 0.1mg/kg/day for 13 weeks. Five monkeys on the highest dose of RDX showed 12 instances of central nervous system disturbances, usually involving tonic convulsion. One of these monkeys was euthanized; the others recovered and survived the study. Except for frequent episodes of emesis, predominantly in the high dosage RDX group, no other clinical signs of toxicologic significance were observed. Lab testing revealed only scattered changes of no toxicologic significance. Histopathologic examination showed some increases in numbers of degenerate or necrotic megakaryocytes in bone marrow sections and increased amts of iron-positive material in liver cord cytoplasm, occurring in the high dosage groups of RDX. The toxicological importance of these two findings is uncertain (Ref 76)

Dogs given daily dosages of RDX of 0.1, 1

or 10mg/kg/day for 90 days developed no signs of toxicity other than temporary episodes of emesis to which a tolerance apparently developed. One medium level animal died for reasons unrelated to the study. Lab diagnostic procedures and both gross and microscopic postmortem examinations revealed no important differences from controls (Ref 75)

A study of the toxicology of RDX distribution and metabolism in the rat and miniature swine made at the Armed Forces Radiobiology Inst at Bethesda (Ref 94) appears to be still in progress. A preliminary report states that "RDX has caused convulsions in military field personnel ingesting it and in munition workers inhaling its dust during manuf. At least one fatality was attributed to RDX toxicity in an European munitions manufg plant. In this country, RDX has been dumped into open pits for disposal after demilitarization, and in some instances has contaminated surface and ground w. It is possible that humans might be exposed to RDX in potable w. This study, initiated at the request of the Naval Medical Research and Development Command, was intended to det the distribution, metabolism and excretion of RDX in lab animals and to estimate by inference the potential hazard to humans from RDX exposure"

A report on an Edgewood Arsenal study on the toxicology of RDX and HMX solns in dimethylsulfoxide, cyclohexanone and acetone states that a study of the toxicology of the expls RDX and HMX in acet, cyclohexanone, and pure and technical grade dimethylsulfoxide (DMSO) was initiated to establish whether there is any danger to plant personnel that handle such mixts. The report contains a review of the existing literature on each expl and on each solvent. It also describes tests that were conducted to establish the intravenous toxicity of the expls in DMSO, skin potential, and the ocular effects of the expls in each solvent. All of these tests were conducted on animals (Ref 77)

XI. RDX Detonators.

An EBW detonator using an RDX expl charge is described in Ref 12. Confined in 1/32 inch ID steel tubes and initiated by the expln of bridgewires 0.2 to 0.5 mils in diam, the

threshold energy for RDX at an "optimum" charge d was 25–30 millijoules. "Optimum" charge d depends on the ratio of bridgewire diam to charge diam. Functioning times of these detonators fired at 2–3.65kv varied between 1.9 to 3.0 microsecs

A low-voltage RDX electric detonator is described in Ref 44. The detonator consists essentially of a donor expl combustion chamber, an impactor disc, an air-gap and an acceptor expl column which provides for proper coupling of the following three critical processes: hot-wire initiation of a self-sustaining deflagration in a 'donor' secondary expl, release and acceleration of a metal impactor disc by confined product gases of the deflagration in the donor expl, and shock initiation-to-detonation of an acceptor secondary expl upon impact by the accelerated impactor disc. The design parameters controlling the critical processes are discussed

The reaction zone of a secondary expl can be subjected to an impulsive rise of pressure leading to deton within tens of microseconds by a technique termed ACP (augmented by collision pressure). This ACP method is claimed to have practical advantages of simplicity and reliability when compared with expl bridgewires and the known procedures for burning to deton. It has been applied to RDX (Ref 45a)

XII. Military Specification.

Military specs for *desensitized* RDX were not given in the Vol 3 article. The "Requirements" (Sect 3) of MIL-R-13742 (3 Nov 1954) are listed below:

Material. The desensitized RDX shall be a thoroughly homogeneous mixt of RDX, complying with Specification MIL-R-398, Type II, Class 1, incorporated with Grade 10 engine oil, complying with Specification MIL-L-2104, to form a light yellow granular mixt

Moisture. Max 0.10 percent

Composition. The proportions of RDX and engine oil in the desensitized RDX shall be as follows:

RDX - 96.0±0.5 percent

Engine oil - 4.0±0.5 percent

Acidity. Max 0.03 percent as acetic acid

Inorganic insoluble matter. Max 0.05 percent

Workmanship. The desensitized RDX shall be

free from foreign matter and visible impurities

The specifications for RDX, MIL-R-398C (22 Aug 1962) have been amended by MIL-R-398C (AR), amendment 4 (12 July 1977).

The major change consists of:

Test	Type I	Type II
Melting point (°C) min	200.0	190.0
Total acetone insoluble material, % max	0.05	0.05
Inorganic insoluble, %, max	0.03	0.03
Insoluble particles, retained on U.S. Standard Sieve No 60, number of particles	5	5
Acidity, %, max	0.05	0.02

Written by J. ROTH

Refs: 1) A.Ya. Apin & L.N. Stesik, in Sbornik "Fizika Vzryva", No 3, 87, Moscow (1955), quotes in Ref 45b 1a) A.Ya. Apin & Yu.A. Lebedev, DAN **114**, 819 (1957) 2) A.N. Dremin & P.F. Pokhil, DAN **128**, 998 (1959) 3) A.Ya. Apin & I.M. Voskoboinikov, Ibid **130**, 804 (1960) & CA **56**, 619 (1962) 4) V.S. Ilyukhin et al, Ibid **131**, 793 (1960) & CA **55**, 24013 (1961) 5) V.S. Ilyukhin & P.F. Pokhil, DAN **140**, 179 (1961) & CA **56**, 6229 (1962) 5a) R.N. Rogers, IEC ProdRes&Dev **1**, 169 (1962) 5b) J.W. Taylor, TransFaradSoc **58**, 561 (1962) & CA **57**, 8970 (1962) 6) C.L. Mader, LA **2900**, 14 (1963) & CA **59**, 8538 (1963) 6a) A.F. Belyaev et al, ZhPriklMekhan i TekhFiz **1963**, 117 & CA **60**, 6691 (1964) 7) K.K. Andreev & S.V. Chuiko, ZhFizKhim **37**, 1304 (1963) & CA **59**, 6190 (1963) 7a) K.K. Adreeev & V.V. Gorbunov, Ibid, 1958 (1963) & CA **59**, 15113 (1963) 8) J. Cerny & J.V.R. Kaufman, JChemPhys **40**, 1736 (1964) & CA **60**, 10467 (1964) 9) A.N. Dremin & K.K. Shvedov, ZhPriklMekhan i TekhFiz **1964**, 139 & CA **61**, 14456 (1964) 10) N.L. Coleburn, NOLTR **64-58** (1964); not found in CA 11) H.H. Blackburn & L.B. Seely, TransFaradSoc **61**, 537 (1965) 12) R. Stresau et al, 4th SympDeton, 449 (1965) 13) A.K. Parfenov & A.Ya. Apin, FizGorVzryva **1**, 109 (1965) & CA **63**, 17786 (1965) 14) V.K. Bobolev & A.V. Dubovik, ZhPriklMekhan i TekhFiz **1965**, 150 & CA **63**, 2840 (1965) 15) H.S. Leopold, NOLTR **65-127** (1965); not found in CA

16) F.P. Stein, PATR **3167** (1965) 17) D. Price & T.P. Liddiard, NOLTR **66-87** (1966) 18) A.F. Belyaev et al, FizGorVzryva **2**, 47 (1966) & CA not found 19) E.N. Aleksandrov et al, FizGorVzryva **3**, 471 & CA **69**, 45001 (1968) 19a) M.L. Weiss et al, Preprints ACS DivFuelChem **11**, 142 (1967) & CA **70**, 98410 (1970) 19b) A.Ya. Apin et al, Vzryvnoe-Delo **1967**, 5 & CA **69**, 4081 (1968) 19c) N.M. Kuznetsov & K.K. Shvedov, FizGorVzryva **3**, 203 (1967) & CA **68**, 4574 (1968) 20) I.A. Karpukhin et al, ZhFizKhim **42**, 39 (1968) & CA **68**, 88691 (1968) 20a) T.C. Castorina et al, PATR **3690** (1968) 21) I.M. Voskoboinikov et al, FizGorVzryva **4**, 45 (1968) & CA **69**, 78872 (1968) 22) G. Norwitz & M. Galan, Rept, FrankfordArns (1968) (AD-673 708) 23) I.M. Voskoboinikov et al, FizGorVzryva **5**, 471 (1969) & CA **72**, 123575 (1970) 24) V.K. Bobolev et al, Ibid **5**, 331 (1969) & CA **72**, 33883 (1970) 25) J.M. Rosen & C. Dickinson, NOLTR **69-67** (1967) & CA **70**, 98400 (1969) 26) M.J. Barbarisi & E.G. Kessler, PATR **3861** (1969) 26a) F.C. Rauch & A.J. Fanelli, JPhysChem **73**, 1604 (1969) 27) S.A.H. Amas & A.H. Yallop, Analyst (London) **94**, 828 (1969) & CA **71**, 103733 (1969) 28) A.V. Obmenin et al, FizGorVzryva **5**, 461 (1969) & CA **72**, 123574 (1970) 29) N.M. Kuznetsov & K.K. Shvedov, Ibid, 362 (1969) & CA **73**, 5588 (1971) 30) J.J. Batten & D.C. Murdie, AustralJChem **23**, 749 (1969) & CA **72**, 104347 (1970) 31) J.J. Batten & D.C. Murdie, Ibid, 737 (1969) & CA **72**, 104348 (1970) 32) J.J. Batten, Ibid **24**, 945 (1970) & CA **74**, 140632 (1971) 33) A. Weisbecker & A.M. Rouquie, CR Ser C **270**, 572 (1970) & CA **73**, 39823 (1970) 34) A.N. Dremin & K.K. Shvedov, FizGorVzryva **6**, 520 (1970) & CA **75**, 89716 (1971) 35) L.V. Afonina et al, VzryvnoeDelo **68**, 149 (1970) & CA **73**, 89713 (1970) 36) E.G.G. Whitbread, BrP 1197891 (1970) & CA **73**, 79085 (1970) 36a) J. Stals, TransFaradSoc **67**, 1739, 1756, 1768 (1970) & CA **75**, 43032 to 43034 (1971) 37) J. Roth, 5th SympDeton, 219 (1970) 38) J. Calzia & H. Carabin, Ibid, 231 (1970) 39) C.L. Scott, Ibid, 259 (1970) 39a) H.H. Licht, SympChemProblemsOfExplStability (Sweden) (1970), 177; not found in CA 40) M.T. Forel et al, JPhysChem **75**, 2056

- (1971) & CA 75, 62979 (1971) 41) P.G. Hall, *TransFaradSoc* 67, 556 (1971) & CA 74, 10382 (1971) 42) V.I. Vashchenko et al, *FizGorVzryva* 7, 429 (1971) & CA 77, 22440 (1972) 43) H.W. Koch & C. Barras, Rept **ISL-28/71-PT-1** (25 Aug 1971) 44) V.F. Lemley et al, S³ Rept 3 **SCR-851** (Nov 1971) 45) J. Cherville, *ComissEnergAT (FR) Rapp* (1971) & CA 75, 89713 (1971) 45a) A.J. Dedman & A.L. Lovecy, *Explosives* 3/4, 19 & 68 (1971) & CA 76, 156299 (1972) 45b) G.T. Afanas'ev & V.K. Bobolev, "Initiation of Solid Explosives by Impact", **TT70-5074**, NASA TTF-623 (1971) 46) J.J. Batten, *AustralJChem* 24, 2025 (1971) & CA 75, 153477 (1971) 47) J.J. Batten, *JApplChemBiotechnol* 21, 163 (1971) & CA 75, 65762 (1971) 48) V.S. Solov'ev et al, *GorVzryv Mater VSES Simp 3rd* (1972) & CA 78, 138465 (1973) 49) M.S. Belyaeva et al, *Ibid*, 785 & CA 78, 135414 (1973) 50) A.L. Krivchenko, *FizGorVzryva* 8, 463 (1972) & CA 78, 161668 (1973) 51) M.A. Mel'nikov & V.V. Nikitin, *Ibid*, 591 & CA 78, 161671 (1973) 51a) M.A. Mel'nikov & V.V. Nikitin, *Ibid* 485 & CA 78, 99950 (1973) 52) P.F. Korotkov et al, *Ibid*, 558 & CA 78, 99950 (1973) 53) T. Urbański, *JArchProcesovSpalania* 3, 117 (1972) & CA 78, 99944 (1973) 54) H.H. Cady, *JChemEngData* 17, 370 (1972) & CA 77, 80309 (1972) 55) C.S. Choi & E. Prince, *Acta-Crystallographica, Sect B* 28, 2857 (1972) & CA 77, 119358 (1972) 56) Z. Iqbal et al, *PATR* 4401 (1972) & CA 78, 130251 (1973) 57) M.K. Kinard, Master's Thesis, *NavPostgrad-School* (1972) & CA 78, 18433 (1973) 58) J.J. Batten, *AustralJChem* 25, 2337 (1972) & CA 78, 6081 (1973) 58a) J.E. Kennedy, *12thSympExplosEngDesign*, 109 (1972) 58b) B.M. Dobratz, "Properties of Chemical Explosives and Explosive Simulants", LLL, **UCRL-51319** (1972) 59) S. Giorgio, **NWC TP 5525** (1973) & CA 80, 56014 (1974) 60) J. Calzia, *CR Ser C*, 276, 1397 (1973) & CA 79, 33273 (1973) 61) A.I. Dubnov et al, *VzryvnoeDelo* 72, 29 (1973) & CA 82, 100891 (1975) 62) R.C. Bowers et al, *IEC Chem-ProdResDev* 12, 2 (1973) & CA 79, 21175 (1973) 63) L. Avrami et al, *PATR* 4602 (1973) & CA 81, 93589 (1974) 64) K. Hollenberg, *EinfuerungssympInstChem-Tech Untersuch* 1973, 272 & CA 82, 100897 (1975) 65) W. Kegler, *Ibid*, 314 & CA 82, 100899 (1975) 66) H.W. Koch, *Ibid*, 478 & CA 82, 100888 (1975) 67) I.S. Klochkov & N.D. Manachinskii, *FizGorVzryva* 9, 570 (1973) & CA 80, 49944 (1974) 67a) K.C. Miller, **TIP-73-168-1190** (1973) 67b) D. Tabor et al, *FinalReptContract DAJA 37-72-C-2584* (1973) 67c) B.N. Kodrikov, *FizGorVzryva* 9, 84 (1973) & CA 79, 21178 (1973) 67d) V.M. Mal'tsov, *Ibid*, 220 & CA 79, 81000 (1973) 68) N.M. Kuznetsov et al, *FizGorVzryva* 10, 791 (1974) & CA 83, 30463 (1975) 69) A.P. Ershov et al, *Ibid*, 864 & CA 83, 12943 (1975) 70) J.D. Cosgrove & A.J. Owen, *CombustFlame* 22, 13 (1974) & CA 80, 135481 (1974) 71) J.D. Cosgrove & A.J. Owen, *Ibid* 19 & CA 80, 110510 (1974) 72) R.R. Bernecker & D. Price, *Ibid*, 119 & CA 80, 110512 (1974) 73) R.R. Bernecker & D. Price, *Ibid*, 161 & CA 80, 110513 (1974) 74) R.N. Rogers, *Thermo-chimicaActa* 9, 444 (1974) & CA 81, 127319 (1974) 75) E.R. Hart, *FinalRept D1711L3, Contr N00014-73-C-0162* (1974) & CA 87, 16769 (1977) 76) Anon, *FinalRept D308281, N0014-73-C-0162* (1974) 77) B.P. McNamara, **EB-TR-73040** (1974) 78) C. Schulz, *8thProcSympExplosPyrotechn* (1974) & CA 82, 75129 (1975) 79) R.G. Gillis et al, *JOrgMassSpectrom* 9, 359 (1974) & CA 81, 77056 (1975) 79a) J. Yinon, *JBiomedMassSpectrom* 1, 393 (1974) & CA 86, 19143 (1977) 80) C. Trinquocoste, *JChim-PhysPhysChimBiol* 72, 689 (1975) & CA 83, 123649 (1975) 81) P.L. Marinkas, *PATR* 4840 (1975) & CA 86, 173768 (1977) 82) S.A. Bordzilovskii & S.A. Karakhanov, *FizGorVzryva* 11, 506 (1975) & CA 83, 118038 (1975) 83) A.P. Ershov, *Ibid*, 938 & CA 84, 138029 (1976) 84) A.N. Afanesenko & V.A. Danilenko, *Ibid*, 915 & CA 84, 138028 (1976) 85) L.K. Isaeva et al, *JZavodLab* 41, 540 (1975) & CA 83, 125880 (1975) 86) V.V. Yakushev & A.N. Dremin, *DAN* 221, 1143 (1975) & CA 83, 292 (1975) 87) A.G. Antipenko, *DAN* 225, 1086 (1975) & CA 84, 107980 (1976) 88) G.C. Whitnack, **NWC-TP-5898** (1976) 89) J.M. Poyet et al, *Analysis* 4, 53 (1976) & CA 84, 152882 (1976) 90) L. Avrami & H.J. Jackson, *PATR* 4964 (1976) & CA 87, 8168 (1977) 91) J. Harris, *Thermo-chimActa* 14, 183 (1976) & CA 84, 107975 (1976)

92) B.D. Faubion, Rept Contr EY-76-C-04-0487, Mason-Hangar Inc (1976) & CA **87**, 170032 (1977) 93) R.E. Hart, FinalRept, D2841K3, Contr N00014-73-C-0162 (1976) & CA **87**, 162402 (1977) 94) N.R. Schneider et al, **AFRRI-SR76-34** (1976) & CA **85**, 137385 (1976) 95) J. Patterson et al, FinalRept Grant EPA-R-802872 (1976) 96) K.K. Jain, Rept Contr DAAG53-75-C-0273 (1976) & CA **85**, 130070 (1976) 97) G.V. Dimza, FizGor-Vzryva **12**, 244 (1976) & CA **85**, 80485 (1976) 98) B. Zygmunt, BialWojskAkadTech **25**, 87 (1976) & CA **86**, 75478 (1977) 99) A.N. Dremine & K.K. Shvedov, 6thSympDeton, 29 (1976) 100) Y. deLongueville et al, Ibid, 105 101) J. Hershkowitz & I. Akst, Ibid, 439 102) L.C. Yang & V.J. Menichelli, Ibid, 612 103) J.O. Erkman & D.J. Edwards, Ibid, 766 104) J.M. Stillwell et al, FinalRept Contr DAMD 17-74-C-4123 (1977) & CA **88**, 41254 (1978) 105) F. Volk, Explosives **30**, 72 (1977) & CA **88**, 54423 (1977) 106) D. Price & R.R. Bernecker, NWS/WOL/TR-77-96 (1977) 107) M. Benreuvén et al, 16thSympCombust, 1223 (1977) & CA **87**, 154285 (1977) 108) R.E. Wynant, FinalRept Contr N00174-75-C-0277 (1977) 109) D. Tabor et al, FinalRept Contr DA-ERO-75-G-008 (1977) 110) J.T. Hagan & M.M. Chaudri, JMaterSci **12**, 1055 (1977) & CA **87**, 103972 (1977) 111) K. Kishore, Propell-Explos **2**, 78 (1977) & CA **88**, 39531 (1978) 112) D.F. Debenham & A.J. Owen, SympChem-ProblemsStabExplos **4**, 201 (1977) & CA **87**, 138049 (1977) 113) C.C. Andrews & J.L. Osmond, Rept WQEC/C-77-32 (1977) 114) D.A. Kubose & J.C. Hoffsommer, NSWC/WOL/TR-77-20 (1977) & CA **88**, 54713 (1978) 115) J.M. Stillwell et al, FinalRept Contr DAMD17-74-C-4123 (1977) & CA **88**, 41254 (1978) 116) T.C. Castorina et al, PATM **2224** (1977) & CA **87**, 72840 (1977) 117) J.C. Hoffsommer et al, **NSWC/WOL/TR-77-30** (1977); no CA ref found 118) A.F. Smetana & S. Bulusi, **ARLCD-TR-77039-Pt-2** (1977); no CA ref found 119) J.E. Abel et al, **ARLCD-SP-77005** (1977); no CA ref found 120) R. Shaw & F.E. Walker, JPhysChem **81**, 2527 (1977)

Reactivity Tests. See under Compatibility of Explosives with other Substances in Vol **3**, C461-L

Reciprocal Laying. Method of making the planes of fire of two guns parallel by pointing the guns in parallel direction. In reciprocal laying, the two guns sight on each other, then swing out thru supplementary angles to produce equal deflections from the base line connecting the two pieces

Ref: Anon, OrdTechTerm (1962), 250

Reclamation of Energetic Material Components from Ordnance Ammunition

The problem of what to do with outdated ammo to prevent both pollution and hazardous situations from occurring is an enormous one which dates back more than a century. At first glance two answers as to what to do with the energetic material components of the ammo become apparent, ie, complete disposal or partial disposal with some recycling. However, close examination of the facts reveals the problems associated with disposal. The various chemical constituents of the warhead, propellant or pyrot are not only explosively hazardous but are frequently of a toxic character. Disposal by dumping into the world's oceans (Refs 26, 27 & 33), incineration (Refs 25 thru 27 & 33) or detonation (Refs 24 & 33) have been shown to be not only dangerous but an addition to world pollution, and as such a persistent universal health hazard (Refs 23 thru 27, 29 & 31 thru 33). Further, the problem of pollution from *all* sources (mil and non mil) became so acute in the United States in the early 1970's that both Presidential Executive Orders and Congressional legislation required that federal and private facilities be set-up or converted to handle both pollution abatement and waste recycling. To this end all US Mil services (plus the AEC) launched or vigorously continued their efforts to develop safe, efficient and non-polluting methods of disposal or recycling of outdated ammo, in particular, their energetic material content

A review of these efforts illuminates the dimensions of the problem. It was found that certain chemical materials such as the relatively stable high expls and pyrots can be easily reclaimed and reloaded [*expl* refs (see Table 1) 1

Table 1
High Explosive Reclamation

Constituent-Composition	Explosive Recovery Technique	Refs
HBX from H-6 compn	A hot w jet erosion process removes the HBX from the warhead, then the w/expl mixt flows into a vac kettle where the w is removed. The dried expl is then dispensed thru a multiported dispenser to an endless steel belt where it solidifies and is broken into flakes as it flows off the belts. Remelting and compn adjustment to form new HBX types or H-6 is then easily performed	27
HMX from PBX 9404 compn	Preferential extrn of the binder with concd (70%) tech grade nitric acid by adding the acid to the PBX compn and heating the mixt to between 70 and 95° for several mins. After cooling to RT the excess acid is withdrawn. The extrn procedure is repeated until the HMX is free of the binder. The acid is then dild with w and the HMX collected by vac filtrn. Yield is 82.0 to 86.6%	26, 27 and 30
HMX from PBX compns developed after 1974	The binders which are incorporated in these post-1974 compns are selected for their heat sensy. For example, polypropylene-glycol-urethane can be degraded when heated to 160° for 10 hrs. The HMX can then be extracted with methylene chloride. See also in Vol.8 under "PBX" compns	31 and 32
RDX from RDX Compn A and RDX and TNT from RDX Compn B	Selective batch extrn of the wax in Compn A using benz in a soxhlet appar leaving the RDX. The TNT in Compn B is extracted either batchwise or continuously in soxhlet appar with benz subsequent to extrn of the wax with heptane. This procedure leaves the RDX intact	12
RDX plus 0.03% desensitizer from Compn A-3	The wax is removed (leaving the RDX) by selective solution using a batch process in which a benz-w azeotrope is continuously circulated thru an agitated Compn A-3/benz slurry	19
RDX from Compn B	Selective solution of TNT and desensitizer with benz in a closed system	16
RDX from Compn C-3	Selective solution of all but the RDX content of the compn is accomplished by agitation of a slurry of Compn C-3 and methanol (or acet) in a kettle	19
Tetryl from Tetryl-metal stearate mixt	Selective solution of the Tetryl by continuous acet extraction followed by w pptn to recover the Tetryl	11
Tetryl from Tetryl-stearic acid mixt	Reaction of the mixt with a dil soln of the Na bicarbonate or carbonate at 90°; cooling to RT and then washing the Tetryl with cold w. The Tetryl is then recryst from acet-w. Large pellets of the Tetryl-stearic acid mixt require pre-treatment with an acet soak	7 and 8
TNT from Amatol	The TNT is extracted with boiling w thru a stainless steel mesh thus removing dirt and metal impurities. After the molten TNT settles it is drawn off and rewashed with boiling w under agitation four times in a similar fashion. The TNT is then pptd in cold w or run directly into graining kettles for immediate reuse	9
TNT from 10/90 and 50/50 Pentolite	Selective solution of TNT with benz at 70° followed by cooling, filtering and evapn of the benz to obtain the TNT	10
TNT and Tetryl from Tetrytol 75/25	Selective solution of TNT using a xylene-heptane (50/50) mixt. This procedure recovers 90% of the Tetryl	13
TNT from warheads	Selective solution using xylene	6

thru 13, 16, 19, 22, 24 thru 27 & 30; *pyrots* (see Table 3) refs 15, 23, 29, 31, 32 & 34], but that solid *proplnts* (see Table 2) which may have a limited storage life, require significant degrees of processing before they can be recycled or converted to other prods (Refs 14, 17, 18, 20, 21, 23, 30 & 33)

As a side light on these efforts it was found that in many instances energetic material component recovery was not economically feasible. Indeed, in one instance Wichman et al (Ref 27) found that recovering the HMX in PBX 9404 (Table 1), which is 94% HMX (selling in 1972 (the publ date) at \$1.20/lb), would cost about \$3.60/lb. Since the storage and handling costs for HMX recovery from PBX 9404 were found to

be about the same as for disposal, it was concluded that this recovery process represented at least an alternative to pollution-free disposal. However, since this study the problem of energy conservation has become of paramount importance. Hence, as a counter-balance to the findings of Wichman et al, the excellent possibility of achieving significant energy and fuel savings thru recycling procedures, strongly favor the recycling of energetic materials rather than even the pollution-free disposal (or the wasting) of these materials

Perhaps one of the most important, interesting and intelligent conclusions which has been drawn from these efforts to lower pollution and save energy thru the recycling of ammo is that in order

Table 2
Propellant Reclamation

Constituent-Ammo Item or Composition	Propellant Constituent Recovery Technique	Refs
Ammonium Perchlorate (or other oxidizer) and fuel from binder	The oxidizer is usually w-soluble. The oxidizer extrn process is efficiently performed with the cooling w used to cool the proplnt grains during the shredding process. The oxidizer is then recryst and reused. The inert binder and metal fuel are further separated for the purpose of recovering the metal either before or after incineration	33
Contaminants from .50 cal ammo	The removal of contaminating igniter and tracer compns from .50 cal proplnt is performed by selective solution using a w spray from a fish-tail type of sprayer which emits the w at a 90° angle to the surface of the proplnt powder as it is vibrated on a Day Roball Gyrator screen	14
NC from deteriorated proplnts	Recovery of NC is performed by solution or dispersion under w, then careful molding to give a colloidal compn of NC	18
NC from single-base cannon powder contg DNT and DBP	Preferential solution of the DNT and DBP using an extrn process with a mixt of benz-w	17
NG from proplnts	A process of selective adsorption is used; ie, a benz soln of the various constituents of the compn are selectively adsorbed on mats such as Fullers earth, silicic acid, activated carbon, activated silicates, etc, followed by a desorption process	20
Reclamation of cured polysulfide-perchlorate proplnts	The waste cured proplnt is reduced to a small particle size by passing it thru a lab mill. It is then added to the extent of 20% of the total mixt to a normal mixt of proplnt. The waste proplnt re-liquefies to its precured state in the mixer by means of a molecular wt redistribution between the low mw liq polymer and the high mw solid polymer. The reaction is complete in about 10 mins	21

to have a safe, effective and efficient program of ammo recycling one must start with ammo that can be readily recycled. To this end, a new concept in ammo design has been evolved.

Ammo items (inclusive of expls, proplnts and/or pyrots) will be *designed and fabricated in such a manner as to be easily and safely recycled* (Refs 24 thru 27, 31 & 32)

The efforts made to-date to recover or recycle individual chemicals in each ammo component category; ie, expls, proplnts and pyrots are presented next:

Explosives. Preliminary removal of the HE charge from the mine, proj or shell usually involves the use of hot w or steam to liquefy the expl which is then separated from the w by gravity (Refs 1 thru 5), or contour drilling followed by high pressure w erosion to remove the HE residue (Ref 27). The new concept of ammo which can be readily recycled *by design*, however, has resulted in the prepackaging or encapsulation of the entire HE charge for easy and safe removal (Ref 24).

After sepn of the casing from the charge, Table 1 summarizes the various procedures which have been developed to recover the individual constituents of the charge

Solid ammo *propellants* are difficult to recycle as the smokeless base(s) (NC and/or NG) used in the ammo will deteriorate with age (Ref 27). Solid rocket proplnts in many instances can be recovered, as shown in Table 2. However, the polymeric binder used in solid rocket proplnts is a cross-linked mat which is insol in solvents,

making it impossible to remove the binder simply by solvent extrn. Furthermore, the finely divided metal and oxidizer particles are intimately coated with the binder, which is also impervious to w, making it impossible to remove a w-sol oxidizer from the metal and binder. This impediment in recycling calls for chemical cleavage of the binder linkage or the use of binder molecular structures which can be thermally degraded (Refs 27, 31 & 32). Liq proplnts, on the other hand, do not present much of a recycling problem. They usually consist of a fuel and an oxidizer which are both usually basic industrial chemicals that can be stored separately for an indefinite period of time (Ref 33). Hence, liq proplnts are always essentially "recovered" before actual use. See also "Liquid Propellants" in Vol 7, L34-R to L44-R

As can be seen from the data in Table 3, little work has been done on recycling the majority of *pyrotechnic* basic mats with the exception of the Mg and Na nitrate in illuminating flares and dyes in smoke compns. Current investigations consist of attempts to recover P from signal flares (Ref 27). However, the work to-date can be considered as a pilot activity which can be further developed and applied to other pyrot items and compns

Written by H. L. HERMAN

Table 3
Pyrotechnic Reclamation

Constituent-Composition	Pyrotechnic Constituent Recovery Technique	Refs
Dyes from Smoke Compns	Preferential solution with w leaves the dye plus other w insolubles for storage and later reuse in new units. The dyes can be further separated by extraction with a dil aq mineral acid such as HCl. If S is present in the dye it can be extracted with alkaline solutions.	15 and 34
Mg from flare compns	W is used to selectively dissolve Na nitrate and most of the binder material. The residual Mg is then dried and sieved. <i>Note:</i> In some instances the binder requires acet or similar solvents. Musselman (Ref 29) suggested component reuseage; viz, Mg as a fuel in other pyrot compns or for sale as scrap, Na nitrate (aq) as a fertilizer or for pyrot reuse, and the binders as land fill	23 and 29

- Refs:* 1) T.F. Knight, USP 1492922-3 (1924) & CA **18**, 2079 (1924) 2) G. Allison, USP 1492949 (1924) & CA, *Ibid* 3) R.H. Bots, USP 1492956-7 & -8 (1924) & CA, *Ibid* 4) M.M. Kostevitch, CoastArtyJ **65**, 373-81 (1926) & CA **21**, 325 (1927) 5) H.S. Deck & P.V. DiCosmo, USP 1958420 (1934) & CA **28**, 4602 (1934) 6) P. Varrato, "Test of Reworked TNT Obtained from Triton Chemical Corporation", PATR **1046** (1940) 7) E.F. Reese, "Develop Process for Reclamation of Tetryl Scrap Containing Stearic Acid", PATR **1131** (1941) 8) J.D. Hopper, *Ibid*, PATR **1137** (1941) 9) F.H. Vogel, "The Recovery of TNT from Amatol Scrap", PATR **1225** (1943) 10) F.R. Benson, "Develop Process for the Recovery of Explosive Scrap", PATR **1284** (1943) 11) *Ibid*, PATR **1287** (1943) 12) *Ibid*, PATR **1338** (1943) 13) F.R. Benson, *Ibid*, PATR **1418** (1944) 14) L.A. Fleck, "Reclamation of Smokeless Powder Obtained from Breakdown of Tracer Ammunition", PATR **1531** (1945) 15) A.M. Reeves, "Recovery of Dyes from Colored Smoke Mixes", CWS TDMR **1228** (1946) 16) M.C. Epton, "Development of Processes for Reworking RDX Compositions", PATR **1715** (1949) 17) D.A. Alderson et al, "Reclaiming Single-Base Smokeless Powder", USP 2642350 (1953) & CA **47**, 9016 (1953) 18) A.B. Garcia, "Stabilization of Nitrocellulose", SpanP 210044 (1953) & CA **49**, 3538 (1955) 19) A. Leschinsky, "Development of Processes for Recovering RDX from Compositions A-3 and C-3", PATR **2154** (1955) 20) W.A. Schmeling, "Reclamation of Nitrocellulose and Nitroglycerine from Scrap Double-Base Propellant", Prog Rept No **5**, Badger Ordn Works, Baraboo (1957) 21) D.R. Brown, "Reclaiming Waste Propellant of the Polysulfide-Perchlorate Type", Final Engrg Rept **RCS-ORDIX135**, OAC Proj No 55-117-BP-98, Thiokol Corp, Denville, Contract DA-11-173-ORD-200 (1958) 22) H. Freytag, "Zur Verordnung über Arbeitsstoffe aus delaborierter Munition", Explosivst **1961**, 12, 293-6 & CA, not found 23) K.A. Musselman, "Flare, Igniter and Pyrotechnic Disposal" in B.E. Douda, Coordinator, "Pyrotechnic Exploratory Development and Pollution Abatement Quarterly Reports" (Limited Dist), NAVAMMODEP **RDTR No 197** (1972), 71-6 24) L.A. Dickinson, "The Impact of Ecological Considerations on Ordnance Disposal", NAVE-ODFAC **TR-142** (1972) 25) F.I. Honea, et al, "Disposal of Waste or Excess High Explosives", **MHSMP-72-47**, USAEC, Mason & Hanger-Silas Mason Co, Inc, Amarillo, Contract DA-11-173-AMC-487 (A) (1972) 26) F.I. Honea & J. Wichmann, *Ibid*, **MHSMP-72-73**, *Ibid* 27) J. Wichmann et al, "Disposal of Waste or Excess High Explosives", **MHSMP-73-1**, USAEC, Mason & Hanger-Silas Mason Co, Inc, Amarillo, Contract DA-11-173-AMC-487 (A) (1972) 28) Anon, "Treatment and Disposal of High Energy Materials", Rept No NMAB-305, USGRDR7319, NTIS No C1445C4 Natl Mats Advisory Bd, Wash (1973) 29) K.A. Musselman, "Isolation and Disposal of Chemical Ingredients Utilized in Illuminating Flares", **RDTR 217**, NAVAMMODEP, Crane (1973) 30) E.E. Leake, "Recovery of HMX (Cyclotetramethylene Tetranitramine) from Scrap PBX-9404 High Explosive", Tech Rept No **219**, **MHSMB-37**, Mason & Hanger-Silas Mason Co, Burlington (1973) & CA **81**, 172455 (1974) 31) D.L. Ross et al, "Applications of Thermally Sensitive Binders as an Ordnance Disposal Method", Prog Rept No **2426-6**, SRI, Menlo Park, Contract No 00170730C-4329, Mod P00001 (1974) 32) D.G. Hendry et al, "Degradable Binders for Ordnance Disposal", Prog Rept No **3693**, SRI, Menlo Park, Contract No N00024-75-C-5007 (1974) 33) D.S. Gaarder et al, Eds, "Environmental Impact Considerations for Disposal of Propellants and Ingredients", CPIA Pub **260**, Johns Hopkins Univ, Laurel, Contract No 0017-72-C-4401 (1975) 34) J.E. Tanner, Jr, "Reclamation Methods for Organic Dye Smoke Composition", NWSC/CR/ **RDTR-50** (1977) *Addnl "limited distribution" Refs:* A) Bob Skinner, Jr, "Development of Cavitating Water Jet for Case Reclamation Facility", Rept No **NOS-IHSP-76-132** (1976) B) A.S. Tompa et al, "Utilization and Disposal of Solid Propellant and Explosive Wastes", Rept No **NSWC/WOL-TR-77-72** (1977)

Recoilless Rifles. They are, as their name implies, nonrecoiling weapons. Therefore, recoil mechanisms or sliding surfaces are not provided and heavy trails, spades, or other force resisting or compensating mechanisms are not required. For this reason, they can be transported more easily than heavier artillery. Elimination of the

recoil mechanism simplifies manuf, assembly, and maintenance of these weapons. The ammo components fired are similar to those fired from the normal recoiling type of artillery, their complete rounds being characterized by a perforated cartridge case. Low wt is a primary military characteristic of these weapons, thus making

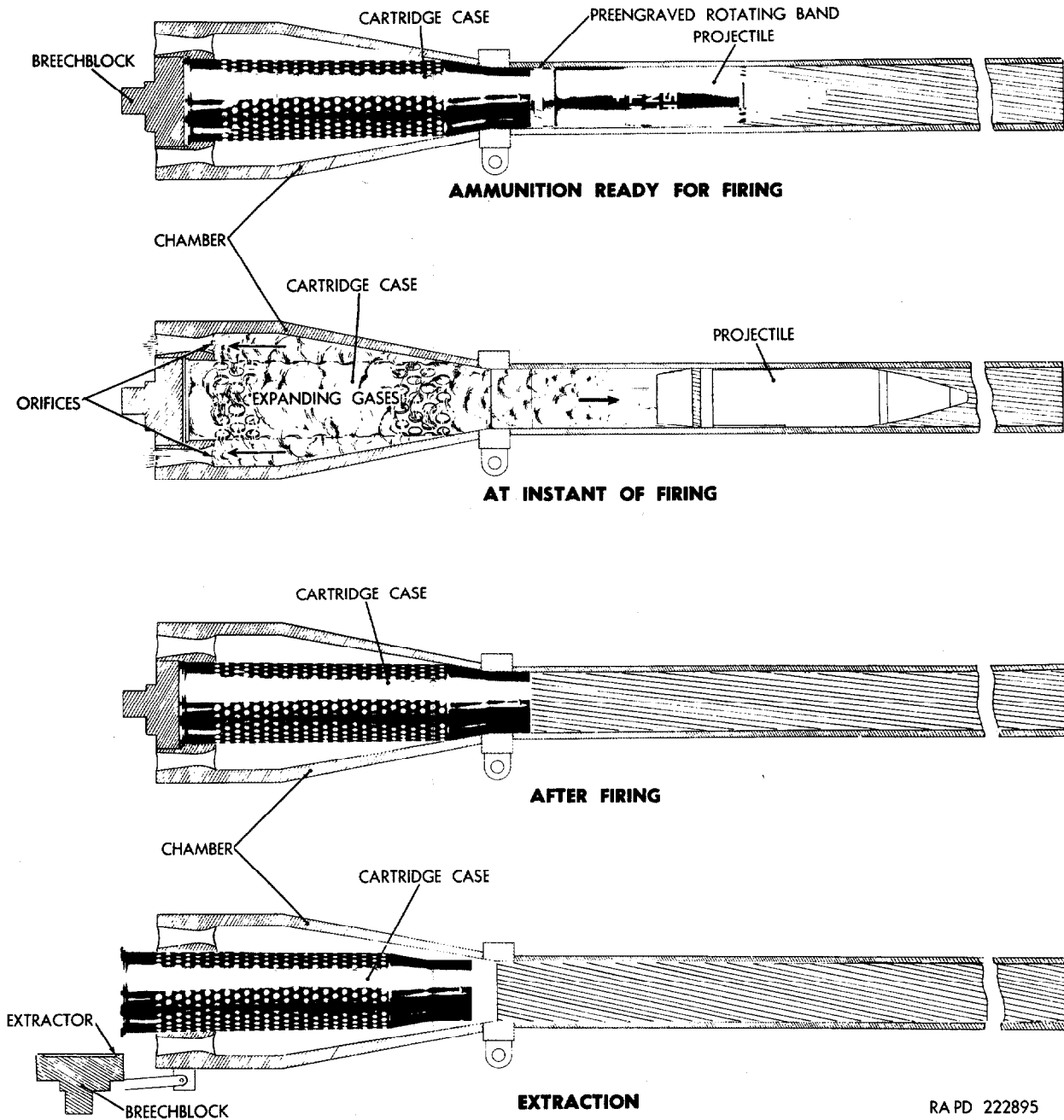

RA PD 222895

Fig 1 Principle of Recoilless Rifles

them particularly valuable as infantry and airborne weapons, especially where the combination of great mobility and large caliber are desired. Lack of recoil permits direct attachment of fire control equipment to the recoilless rifle, thus contributing to its overall accuracy

In the general design of recoilless rifles, vents or orifices are located in the rear of the chamber to carry off part of the propellant gases. These orifices are openings that pass thru the breechblock, thus providing an opening from the chamber to the atm behind the weapon. Unlike other weapons, the inside diameter of the chamber is considerably larger than the cartridge case; therefore, the complete round is suspended in the center of the chamber. Cartridge cases used in these rounds are perforated and the cases are lined with heavy moisture-resistant paper. The perforations allow escape of gas to the sides of the chamber and then to the rear of the gun thru the orifices. The projectiles used in these rounds are preengraved, that is, the rotating bands are cut to engage the rifled bore (Ref 1)

When the rifle is fired (Fig 1), part of the gas propels the projectile forward in the normal manner, and the remainder of the gas escapes thru the perforated cartridge case and thru the orifices to the rear of the weapon. The momentum of the gas escaping to the rear is controlled by the size of the orifices, thereby balancing and counteracting the forward momentum of the projectile and the propelling gases leaving the muzzle. Controlling the gas in this manner counteracts any motion in the weapon. The design of the vent and cartridge case and the quantity of propellant are important factors in maintaining this balance between forward and rearward momentums of the projectile and gases (Ref 1)

The effective range of recoilless weapons is much smaller than with full-recoil weapons. For calibers of about 100mm range, a recoilless rifle will have a max range of 1000–2000 yards, as opposed to a full-recoil gun range of about 25000 yards. But the ratio of weapon wts is also of the order of 1 to 20 even counting the wheeled mounts used with some recoilless rifles. Recoilless weapons are used whenever the range is secondary to the size of the shell delivered, and where high velocities are not required. They are in fact primarily intended for

anti-tank use, where their "hollow charge" HEAT shells penetrate armor without needing the kinetic energy required by conventional solid shot fired from full-recoil artillery (Ref 2)

The US 106mm recoilless rifle and two earlier US models which can be fired from the shoulder, the 75mm and 57mm, are widely used in the West; the Soviet B-11 107mm and the older B-10 82mm are equally popular in the East. Another widely used type is the one-man 84mm "Carl Gustav", manufd in Sweden and used by, among others, the Brit army. The largest recoilless weapon, the Brit 120mm "Wombat", is not widely used (Refs 2 & 3)

See also under "Recoilless Gun" in Vol 2, C28-R to C29-R

Refs: 1) Anon, "Principles of Artillery Weapons", TM9-3305-1 (1958), 167–68 2) E. Luttwak, "A Dictionary of Modern War", Harper & Row, NY (1971), 74–75 3) F.W.A. Hobart, Ed, "Jane's Infantry Weapons—1975", Franklin Watts, NY (1974), 756–59 (Swed), 782–83 (USSR), 786–88 (Brit) & 812–13 (USA)

Reddy Fox. A type of US Navy bangalore torpedo (see Vol 2, B16-R to B18-L) used for blowing up obstacles during landing operations in WWII. It consisted of a long length of pipe filled with expls

Ref: J. Quick, "Dictionary of Weapons and Military Terms", McGraw-Hill, NY (1973), 370

Redeye Guided Missile (MIM-43A). A US shoulder-fired guided missile system designed to provide combat units an effective defense against low-flying aircraft

The Redeye weapon consists of three major components — a launcher, missile, and launcher battery/coolant unit. The missile is sealed in the launcher and is not removed in the field except by firing. The launcher houses the missile and provides the controls and power and coolant channels necessary for target acquisition and firing. The launcher battery/coolant unit is inserted immediately before firing. The Redeye launcher consists of a launch tube, open sight assembly and gripstock. It provides the means of transporting, aiming and firing the missile,

and is discarded after the missile is fired. The launch tube is a cylinder containing the missile, in a constant low humidity environment. The front end seal is transparent to infra-red radiation to allow the missile to sense the target

The open sight assembly allows the operator to aim the weapon, track the target, estimate range and apply tangent elevation. The sight carries an audible and vibratory indicator to show that the missile seeker has acquired the target

The Redeye missile is supersonic, using passive infra-red homing and proportional navigation guidance. It contains a seeker section with an IR detector which converts the target IR radiation into an electrical signal which locks the seeker on the target and generates guidance commands for the missile during flight. The seeker tracks the IR source after the gyro is uncaged. The missile also houses controls and motor driven fins. One pair of fins is stationary during flight, and the other is moved in response to the signals from the seeker section. The missile battery is inert at ambient temps. When the trigger is pressed an electric squib ignites a thermite charge which melts the electrolyte to develop a 40 volt output within 0.5 sec. The fuse timer ignites the sustainer motor, arms the warhead and prepares it for detonation

The conventional HE warhead, when armed, can be detonated in one of three ways: (1) when it penetrates a metal object a firing pulse is generated; (2) when it decelerates on contact with a solid object; and (3) it destroys itself after 15 sec flight (Ref 2)

The Redeye missile length is 1.22m, diameter 70mm, and wt 13kg. It has no IFF (Identification-Friend or Foe) facility and target identification is carried out solely by the firer. Redeye can only effectively attack a jet from behind, and so contributes less than was hoped for in preventing an aircraft from pressing home its attack. Its successor, **Stinger** (qv), is intended to have an all aspect infra-red seeker (Refs 1, 2 & 3)

Operation. The operator sees the target and if he decides to engage, the following sequence occurs and must be completed within 30 secs. When the target is in range the safety and actuator device is operated. This activates the battery coolant unit and Freon gas flows to the seeker and expands to cool the IR detector unit

to 100°F which is its most efficient working temp. The sight is placed on the target and the IR radiation received is focused onto the detector cell. When sufficient energy is received to enable seeker tracking, an audible tone is generated and the gyro which has spun up to speed, is uncaged as soon as the uncaging switch is held down. The ejector motor fires and the exhausting gas impinges on the tail fins – which are still folded – and the missile spins at full rate inside the launcher. When the ejector produces a missile acceleration of 28g an inertial switch in the fuse timer closes and the fuse timer starts. The missile emerges from the launcher under the force of the ejector motor and coasts for about 7m until the sustainer motor fires (to protect the operator). The fuse arms the warhead 1.6 secs after the fuse timer starts, and simultaneously, the self destruction cycle is initiated. The seeker section detects any difference between the gyro line of sight and the source of IR energy. The tracking error signal is then used in a tracking servo-loop to reposition the seeker so that it is aimed at the target. The fins are moved by the control section activated by the seeker signals. When the target is struck the warhead is activated. If the target is missed, the self destruction circuit functions (Ref 2)

Development of the Redeye began in 1959 after a feasibility study in the previous year. A production contract was placed with the General Dynamics Corp, Pomona Division, Pomona, Calif, in 1964 and the delivery schedule was completed in 1970. The rocket motor was made by the Atlantic Research Corp (Refs 2 & 3). Redeye is used by the USMC as well as the US Army, and has also been supplied to the Australian and Swedish armed forces. It is employed in the forward battle area to protect combat troops against low-level aircraft. In the US Army the weapon is issued to Redeye teams, each made up of a gunner and assistant gunner. From 4 to 6 of these teams are assigned to a Redeye section at infantry battalion level (Ref 3)

Refs: 1) E. Luttwak, "A Dictionary of Modern War", Harper & Row, NY (1971), 163
 2) F.W.A. Hobart, Ed, "Jane's Infantry Weapons-1975", Franklin Watts, NY (1974), 805-06
 3) R.T. Pretty, Ed, "Jane's Weapon Systems-1977", Franklin Watts, NY (1976), 98

Red Fuming Nitric Acid. See under "Nitric Acid" in Vol 8, N89-L to N99-L, and under "Nitration", N40-R ff

Red Gum. See under "Gum-tree" in Vol 6, G187-L

Redoutable. Fr nuclear-powered ballistic-missile submarine. Launched in 1967 and due for completion in 1970, it is the first of a class of "third-generation" nuclear-delivery vehicles planned for the 1970's. They are patterned on the US Polaris submarine and are intended to carry 16 underwater-launched missiles designated MSBS (Mer-Sol Balistique Stratégique)
Ref: E. Luttwak, "A Dictionary of Modern War", Harper & Row, NY (1971), 135 & 163

Red Phosphorus. See under "Phosphorus (Red)" in Vol 8, P251-R to P253-L

Red Sod. A US repetitive expl device for soil displacement
Ref: J. Quick, "Dictionary of Weapons and Military Terms", McGraw-Hill, NY (1973), 370

Red Star. A Brit sporting powder introduced in 1906 contg NC (insol) 52.2, NC (sol) 25.5, metallic nitrates 10.5, nitro-hydrocarbons 7.0, vaseline 3.0 and moisture 1.8%
Ref: Marshall 3 (1932), 96

Red Top. A Brit infra-red homing air-to-air weapon for use against sub- and supersonic aircraft. All-altitude operation is possible against maneuvering targets and all-aspect attack capability is provided by its homing and guidance system. At one time referred to as Firestreak Mk IV, Red Top has a similar configuration and dimensions of the same order, but performance is considerably higher as a result of the application of advances in technology made since the start of Firestreak production

Missile dimensions are length 3.27m, diameter 22.2cm, and wing span 90.8cm. It has an un-

officially quoted speed of Mach 3, and a range of at least 12km. The warhead weighs about 68 lbs and is fitted with a proximity fuse
Refs: 1) E. Luttwak, "A Dictionary of Modern War", Harper & Row, NY (1971), 164 2) J. Quick, "Dictionary of Weapons and Military Terms", McGraw-Hill, NY (1973), 370 3) R.T. Pretty, Ed, "Jane's Weapon Systems-1977", Franklin Watts, NY (1976), 166

Redundancy. The existence of more than one means for accomplishing a given task, where all means must fail before there is an overall failure to the system. *Parallel redundancy* applies to systems where both means are working at the same time to accomplish the task, and either of the systems is capable of handling the job itself in case of failure of the other system. *Standby redundancy* applies to a system where there is an alternate means of accomplishing the task that is switched in by a malfunction-sensing device when the primary system fails
Ref: Anon, OrdTechTerm (1962), 251-52

Reefing Line Cutter. See under "Propellant Actuated Devices (PAD's)" in Vol 2, C71-R

Reflection and Refraction Methods. See under "Seismic Prospecting" in this Vol

Regensburger's Explosive. An expl patented in Ger in 1897, prep'd as follows: Molasses was heated with aq hydrogen, Na or Ba peroxides to destroy oxidizable impurities, and then allowed to stand for several hours until the evolution of gas ceased. This was followed by partial evap'n of the molasses, then mixing with 20-25% of mineral or animal oil, and heating the mixt with constant agitation until a density of 40-42 B \acute{e} was attained. With continuing agitation, the mass was cooled and then nitrated to produce an expl
Ref: Daniel (1902), 670

Register. 1) To adjust fire on a visible point, called a "checkpoint", and compute accurate

adjusted data so that firing data for later targets may be computed with reference to that check-point. 2) To adjust fire on several selected points in order that they may serve later as auxiliary targets

Ref: J. Quick, "Dictionary of Weapons and Military Terms", McGraw-Hill, NY (1973), 370

Regulus. A surface-to-surface jet-powered guided missile developed for the US Navy in the 1950's. It was equipped with a nuclear warhead and was launched from surfaced submarines or cruisers. It was essentially a pilotless aircraft with a range of about 500 miles. Designated RGM-6/15

Refs: 1) Anon, Ordn **38**, 753 (1954)

2) J. Quick, "Dictionary of Weapons and Military Terms", McGraw-Hill, NY (1973), 370

Reichen Powder. Same as "Melland Powder".

See in Vol **8**, M56-R

Ref: Daniel (1902), 670

Reid and Earle Explosive. Patented in Fr in 1896. It was prepd by mixing 1p of the product of nitration of linolein or ricinolein with 9p of NC

Ref: Daniel (1902), 670

Reinsdorf Explosion. The spent acid from the trinitration step in the manuf of TNT has been the cause of several disasters, although it had been considered safe to handle. The most noteworthy example of this occurred in the Reinsdorf factory in Ger in 1935. The hot spent acid flowed down to open iron tanks, where, as the liq cooled, a mixt of di- and tri-nitrotoluenes rose to the surface. It was skimmed off from time to time and transferred to a washing tank, where it was washed with w. On skimming, a rubber glove and a shelf left on the edge of the tank with some cotton wool on it, fell into the tank. The reaction between the spent acid and the rubber and cotton wool initiated violent decompn and fire. An attempt to extinguish the flames failed, and soon the nitro compds on the surface of the spent acid expld. The expln

and fire spread over several nearby tanks, then to the nitro compds in the washing tank. As a result the whole plant for the recovery of nitro compds was destroyed. In addition to this, the expln tore away the roofs of some nearby bldgs, among them drier bldgs located at a distance of about 660m. Parts of the tank thrown off by the expln into one of the driers detonated the TNT present, and in another they caused ignition of the load. Similar explns and fires spread to further bldgs of the TNT plant. Moreover, a neighboring NG plant also expld. This disastrous expln cost 82 lives, and in addition 104 persons were seriously and 700 were slightly injured
Refs: 1) Anon, SS **30**, 332 (1935) & CA **30**, 866 (1936) 2) Urbański **1** (1964), 391-92

Reintri. Ger or Swiss term for purified TNT with a mp of 80.0 to 80.6°

Ref: PATR **2510** (1958), Ger 206-L

Relais, Explosif pour (Fr). A booster expl mixt of 95/5 PETN/MNN, compressed to a d of 1.6g/cc, was used to det the vel of deton of EDDN (Ref 1). This mixt was called *Mélange NPMn 95/5* by Médard (Ref 2), who used it compressed to 1.6g/cc in 30mm diam cartridges having charge wts from 10-50g. He claimed that this mixt possesses the same initiating efficiency as straight PETN, but is easier to compress and does not break on handling as does straight PETN

Another booster expl, called "Relais d'acide picrique cristallisé" by Médard (Ref 2), consists of crystalline PA packed to a d of 1.10g/cc in kraft paper cylinders 30mm in diam contg a charge wt of from 10-50g

Refs: 1) A. LeRoux, MP **32**, 123 (1950)

2) L. Médard, MP**33**, 339 (1951)

Relay. An expl train component that provides the required expl energy to reliably initiate the next element in the train. Specifically applied to small charges that are initiated by a delay element and, in turn, cause the functioning of a detonator

The usual relay consists of an Al cup into which LA is pressed. Typical relays are shown in Fig 1

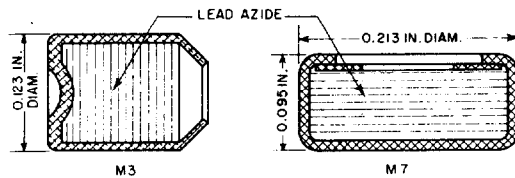

Fig 1 Typical Explosive Relays

In some relays, a sealing disk is crimped over the open end while in others, the end is left open, but the skirt left by partial filling is crimped to an angle. When such relays are inserted into delay elements and crimped in place, the crimp is compressed just sufficiently to result in a firm and snug fit

The input characteristics of relays are difficult to characterize in terms that are significant indications of performance under usual conditions. These items are usually initiated by the spit of a primer, the heat from a delay column, or other action of previous expl elements. The exact mechanism of initiation varies with the application. In some cases, the flame may ignite the expl; in others, either the impact or heat of solid particles or a shock wave may play important roles. No useful, quant results have been obtained with gap tests to det sensitivity of the items

Also see article on "Primers" in Vol 8, P372-L ff and under "Delay-Relay Element" in Vol 3, D54-L

Refs: 1) Anon, OrdTechTerm (1962), 253-R
2) Anon, "Explosives Series, Explosive Trains", EngrgDesHndbk, AMCP 706-179 (1974), 5-2, 5-3 & 5-8

REM. Röntgen Equivalent Man. A measure of the effects of radiation, other than gamma or X-rays, derived by multiplying the energy yield of the radiation by a ratio which expresses that radiation's effect on man

Ref: E. Luttwak, "A Dictionary of Modern War", Harper & Row, NY (1971), 164-R

Rendering Safe Procedure (RSP). The tools and methods employed against an expl device or munition designed to neutralize or otherwise make safe the fuzing system, so that it can be assumed safe for transportation and disposal.

Any method which could detonate or initiate the munition would not be considered a true rendering safe procedure in bomb disposal circles

Refs: 1) J. Stoffel, "Explosives and Homemade Bombs", Charles C. Thomas, Springfield (1972), 144-85 2) R.R. Lenz, "Explosives and Bomb Disposal Guide", Charles C. Thomas, Springfield (1973), 280

Rendite. An older Australian expl contg PA (max 20%), K nitrate, sulfur and woodmeal (with or without graphite)

Ref: Daniel (1902), 671

Renovation of Ammunition. The term, as used by the US Army, includes those maintenance operations necessary to restore to a serviceable condition an article which has deteriorated, been damaged, etc, and which cannot be made serviceable by current "reconditioning" operations (cleaning, repainting, remarking, and repacking). It usually involves the replacement of some deteriorated component such as adapter and booster, primer, propellant, or shell bursting charge. It may also include alterations in the original design, as for example, replacement of booster assemblies in HE separate-loaded projectiles which have become unserviceable due to deterioration by serviceable booster assemblies. This operation might also include reconditioning activities incidental to the completion of the renovation operation

The terms "rehabilitation" and "overhaul" have in the past been used synonymously with "renovation", but the latter term has been officially adopted for use

Renovation activities in many instances include "salvage" operations, wherein the resultant by products of the renovation operation are recovered for the purpose of future reworking to serviceability, or for processing to a point where they may be sold as scrap

The work involved in renovation requires the use of specialized equipment, as in operations for the defuzing and deboosting of shells, removing shell fillers, gaging, etc. Many of the operations are hazardous and require suitable barricading as well as compliance with safety

regulations

Refs: 1) Anon, "Ammunition Renovation", **TM 9-1905** (1948) 2) Anon, *OrdTechTerm* (1962), 254-R 3) Anon, "Care, Handling, Preservation and Destruction of Ammunition", **TM 9-1300-206** (1964)

Requa Battery. A .58 cal weapon developed in 1861 and used during the American Civil War. It featured 25 barrels arranged horizontally and designed to fire volleys. It required a crew of three and could be fired at the rate of 7 volleys, or 175 shots, per min. It had an effective range of 1300 yds. It was sometimes called a "covered-bridge" gun, since it could effectively break up any charge across a bridge (many of which, at the time, were wooden bridges with roofs and sidewalls)

Ref: J. Quick, "Dictionary of Weapons and Military Terms", McGraw-Hill, NY (1973), 371

Résidée. Fr name for compn termed "Oxidized Rosin" by Davis. Its prepn and uses are described under "Colophony—Starch Nitrated Mixture" in Vol 3, C404-L

Resin. Resins of either natural or synthetic origin are discussed in the following articles throuth the Encyclopedia: Vol 1: "Acrylic Acid and Derivatives" (A96-R to A97-R); "Adhesives" (A102-L to A103-R). Vol 2: "Bakelite" (B4-R); "Binder or Agglutinant" (B120-R); "Bonding Agents or Adhesives for Ordnance" (B242-L to B242-R); "Bomb, Plastic" (B225-L). Vol 3: "Colophony or Rosin" (C403-R to C404-L); "Commercial Plastics" (C460-L); "Composite Propellants" (C465-L to C474-L); "Coumarone-Indene Resins" (C550-L); "... Melamine . . ." (C589-L). Vol 6: "Formaldehyde Polymers" (F164-L to F165-L); "Gum(s)" (G186-L to G187-R). Vol 7: "Laminac 4116"

L3-R). Vol 8: "Melamine" (M55-R); "Paraformaldehyde" (P11-R); "Paraplex" (P12-L); Parlon (P14-R)

Refs: 1) Kirk & Othmer 17 (1968), 379-91 2) *CondChemDict* (1977), 749

Resina Explosiva (Span). (Résine explosible or Vixorite in Fr). An expl prepd by A. Pellier in 1886 by nitrating refined sugar with mixed nitric-sulfuric acids. It was a brown resinous material, mp ca 70°, with a compn between pentanitrosaccharose, $C_{12}H_{17}(NO_2)_5O_{11}$, and hexanitrosaccharose, $C_{12}H_{16}(NO_2)_6O_{11}$. It was a slightly weaker expl than guncotton

Note: The expl called Nitrosacarosa (Nitrosugar) contains about four nitrogroups, $C_{12}H_{18}(NO_2)_4O_{11}$

Refs: 1) Daniel (1902), 603 (under Pellier) & 672 (under Résine explosible) 2) Gody (1907), 397 3) Sancho (1941), 179

Resinates. Salts of the mixed resin acids found in rosin (Ref 7). See "Colophony or Rosin" in Vol 3, C403-R to C404-R. There is one salt of particular interest; viz, **Calcium Resinate** (or Limed Rosin). $Ca(C_{19}H_{29}COO)_2$; mw 643.10; OB to CO_2 -261.23%; light yel amorph powdr or lumps. Sol in mineral ac, amyl acetate, amyl alc, butyl acetate, eth, ligr and naphtha; insol in w. Prepn is either by boiling $Ca(OH)_2$ with rosin and filtering or by fusion of hydrated lime and melted rosin. The resinate is flammable and heats sponty (Refs 6 and 7). Its hygry is tabulated below as gain in mgs/g at RT after equil was established in static and vac desiccators (Ref 5)

Calcium resinate has been used in detonators with RDX in the form of a 50/50 mixt with graphite to the extent of 2% of the compn (Ref 2). In the invention of Clay and Sahlin (Ref 3), it comprises 7% of an igniter compn for tracer projs along with SrO_2 (78%), BaO_2 (4%), PbO_2

Time	65% RH		75% RH		86% RH		93% RH	
	Static	Vac	Static	Vac	Static	Vac	Static	Vac
24 hrs	14.0	8.3	11.5	14.1	25.4	19.0	27.1	23.4
1 wk	12.8	12.1	13.0	12.5	23.2	25.6	23.9	27.5
30 days	—	—	14.1	—	27.7	—	30.9	—

Table 1
Chemical and Physical Properties

	Type I	Type II
Calcium resinate content, percent ^a	56.0 min	77.0 min
Acid number ^b	64 max	33 max
Chloroform-insoluble matter, percent ^c	2.0 max	3.0 max
Water content, percent ^d	2.0 max	5.0 max
Flame test ^e	Yellow-red	Yellow-red
Granulation thru 60 (250 microns) sieve, percent ^f	none	75 min
Granulation thru 4 (100mm), percent ^g	90	

Footnotes to Table 1:

- a - as detd by titration with a std disodium-dihydrogen-ethylenediaminetetraacetate (Versenate) soln to a blue Eriochrome Black T indicator end pt
 b - by titration with a std NaOH soln to a phenolphthalein end pt
 c - detd gravimetric by loss in wt
 d - detd volumetrically by CCl₄ displacement of the w in the resinate sample during reflux
 e - quant detn of Ca content by the pure yel-red flame color with no green (from Ba)
 f - detd gravimetrically from the amt of sample remaining in the appropriate sieve nest and on the pan after processing by a RoTap machine for 10 mins at a rate of 300 ± 15 gyrations/min and 152 ± 10 taps of the striker/min
 g - detd gravimetrically as in "f"

(4%) and Ca silicide (7%). Its greatest use to date, however, is as a retardant fuel and binding agent in pyrots. It imparts a yel-red color to the burning pyrot compns and also acts as a waterproofing agent (Ref 5)

The USA mil spec (Ref 4) lists the following requirements for Type I (yel or brn amorph powdr) and Type II (yel-white amorph powdr) material (Table 1)

Refs: 1) Beil, not found 2) S. Fleischnick, "Development of Improved Detonators", PATR 1751 (1950) 3) F.B. Clay & R.A. Sahlin, USP 2709129 (1955) & CA 49, 14326 (1955) 4) Anon, "Calcium Resinate", MIL-C-20470A (Dec 1961) 5) Anon, EngrgDesHdbk, "Properties of Materials used in Pyrotechnic Compositions", AMCP 706-187 (Oct 1963) 6) H.F. Mark, Ed, "Encyclopedia of Polymer Science and Technology" 12, Interscience, NY (1969), 141-42 7) CondChemDict (1977), 748

Resins, Combustible. Compds corresponding to the formula RCX₂NO₂ (where R denotes H, alkyl, aryl or alkylol, and X stands for H or -CH₂OH). Prepn involves 1 to 3 moles of an aliphatic aldehyde, preferably formaldehyde, in an alkaline, neutral or acid medium. Typically,

1 mole of 1-nitropropane when heated at 50° for several hrs with 3 moles of 5 to 40% formaldehyde mixed with 1 mole of Amm hydroxide forms a viscous, yel, thermoplastic resin suitable for the gelatinization of NC. Mp, violent decompn on heating; d 1.2g/cc at 20/20°; ign temp 230°; visc 8000 poise at 20°; sol in aromatic nitro compds such as NG

Refs: 1) T. Urbański, USP 2419043 (1947) & CA 41, 4332 (1947) 2) Ibid, BritP 60101 (1948) & CA 42, 7571 (1948)

Resistance to Detonation of an Explosive. See under "Detonation (and Explosion), Resistance to" in Vol 4, D508-L to D510-L

Resolution. Class of Brit nuclear-powered ballistic missile submarine. Four Resolution class submarines, each equipped with 16 Polaris A3 missiles with multiple (but not MIRV) warheads, form the second generation of Brit strategic offensive forces. The missiles and some other parts are based on US components or designs, but the ship and the missile warheads are locally produced. The main external difference between these and the Polaris type submarines is in the

diving planes, set on the bow instead of on the superstructure, and the "whale"-type forward hull, similar to that of the first George Washington class of US fleet ballistic missile submarines
Ref: E. Luttwak, "A Dictionary of Modern War", Harper & Row, NY (1971), 164

Resonance Burning. A term applied to a type of unstable burning sometimes encountered in rocket motors. This condition is found most frequently with tubular charges where pressure peaks may be accompanied by break up of the proplnt grains. The central perforations of partially burned grains exhibiting resonance burning are found to have a rippled surface resembling a standing wave pattern

The occurrence of resonance burning appears to be closely related to the location of the stagnation point, the point of zero gas velocity within the grain perforation where the combustion gases flow outward in opposite directions. Resonance appears to be observed only when the charge geometry is such that the stagnation point occurs within the perforation of the grain. Empirically it has been found that resonance burning can be prevented by drilling radial holes in the grain, by placing a small non-combustible rod in the perforation, by the use of perforations of noncircular cross section, or by adding small quantities of finely-divided Al to the formulation. In each case a "quick-fix" has been accomplished, but no real explanation has been given for the phenomenon

A limited amt of study has been given to the mechanism of resonance burning. Since the rate of burning of most proplnts is a strong function of pressure and proplnt temp, a small fluctuation in pressure in the gas stream near the burning surface will cause a corresponding fluctuation in the burning rate at the adjacent surface. This will have the effect of reflecting the disturbance in an amplified form

Refs: 1) A.M. Ball, "Explosives Series—Solid Propellants, Part One", *EngrgDesHndbk*, **AMCP 706-175** (1964), 17 2) R.T. Holzmann, "Chemical Rockets and Flame and Explosives Technology", Marcel Dekker, NY (1969), 70–71

Resorcin, Dinitro (Ger). See under "Dinitro-derivatives of Dihydroxybenzene" in Vol 5, D1273-R to D1274-R

Resorcin, 2,4-Dinitroso (Ger) (2,4-Dinitroso-1,3-dihydroxybenzene or 2,4-Dinitrosoresorcinol, which rearranges to the tautomeric form, ie, Cyclohexene-(1)-tetron-(3,4,5,6)-dioxime-(3,5); Cyclohexene-(1)-dion-(4,6)-dioxime-(3,5)- or Dichinoyl-dioxime)

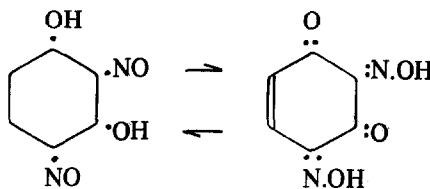

mw 168.12; N 16.67%; OB to CO₂ -95.17%; yel-grn to bronze plates; mp, turns brn at 140° and explds at 162–63°, 164–66° (separate values). Sol in ethanol, acet and w; v sl sol in boiling chl_f, petr eth and toluene. Prepn is by reacting resorcinol with a 50% aq soln comprised of a mixt of two gm equiv wts each of acetic acid and K nitrite at 0°. The reaction is allowed to proceed for a quarter of an hr, the mixt is poured into a 2 molar aq soln of sulfuric acid and, after one hr, the cryst ppt is filtered off. Re-crystn is from 50% aq ethanol as the monohydrate. The yield is 94.6%

The acid salts of this compd with heavy metals such as Pb and Ag and with alkaline earths such as Ba and Cd are termed *2,4-Dinitrosoresorcinates*. These compds were patented by Brün and Burdett (*Ref 2*) as ingredients of some priming and ign compns. The salts of Ba, Cd, Pb and Ag are prepd by dropwise addn of an aq soln of a w sol salt of the metal to a dil alkaline aq soln of 2,4-Dinitroso-resorcinol at 70°. The ppt is w-washed and air-dried. A typical compn including one of these salts (in quantities of from 1 to 15%) is: the acid or alkaline heavy metal Dinitrosoresorcinat 8, Lead Styphnat 40, Tetracene 2, Pb nitrate 30 and powdered glass 20%

Probable formulations and descriptions of these salts are: *Acid Barium Salt*, Ba(C₆H₃N₂O₄)₂; brn amorph mass; *Acid Cadmium Salt*, Cd(C₆H₃N₂O₄)₂ + H₂O, brn amorph mass; *Acid Lead Salt*, Pb(C₆H₃N₂O₄)₂, dk grn amorph mass; and

Acid Silver Salt, $\text{AgC}_6\text{H}_3\text{N}_2\text{O}_4$, dk grn hard mass

In another patent, Sakamaki (Ref 3) used the Ag or Pb salt in an elec deton device compn with 5% collodion as a binder

Refs: 1) Beil 7, 885, (490), [851] & {4732}
2) W. Brün & P.H. Burdett, USP 2350670 (1944) & CA, not found 3) T. Sakamaki, JapP 147(51) & CA 46, 11690 (1952)

Resorcin, Nitro (Ger). See under "Mononitro-dihydroxybenzene" in Vol 5, D1271-L

Resorcin, Tetranitro (Ger). See under "2,4,5,6-Tetranitroresorcinol" in Vol 5, D1288-R

Resorcin, Tetranitro, Äthyläther (Ger). See under "Monoethylether deriv" of "2,4,5,6-Tetranitroresorcinol" in Vol 5, D1288-R

Resorcinate, 2,4-Dinitroso Metal Salts. See under "Resorcin, 2,4-Dinitroso . . ." above

Resorcinate, Lead Dinitro. See under "Lead 2,4-Dinitroresorcinate (LDNR)" and "Lead 4,6-Dinitroresorcinate, Basic (LDNR, Basic)" in Vol 5, D1274-R to D1275-L and D1275-R to D1276-R. The normal lead salt is also listed under Ref "Ad163)" in Vol 4, D1052-R

Resorcinate, Lead Trinitro (Lead Styphnate). See under "Lead Styphnate, Basic" and "Lead Styphnate, Normal" in Vol 5, D1277-L to D1278-R and D1278-L to D1288-L. Other lead salts of trinitroresorcinol are listed as such on D1288-L of Vol 5

Resorcinate, 2,4,6-Trinitro, Lead Salt Containing Methyl Cellulose. See under Ref "Ad 157)" in Vol 4, D1050-R to D1051-L

Resorcinic Acid. A misnomenclature or misinterpretation of the Ger "Resorcin-carbonsäure" applied to Styphnic Acid (Ref) in the

prepn of Lead Styphnate. See under "2,4,6-Trinitro-1,3-dihydroxybenzene" in Vol 5, D1276-R to D1277-L

Ref: E. Von Herz, USP 1443328 (1923) & CA 17, 1551 (1923)

Resorcinol (1,3-Dihydroxybenzene). See under "Dihydroxybenzene and Derivatives" in Vol 5, D1270-R

Addnl Refs: 1) Anon, "Resorcinol", MIL-R-60864 (Dec 1967) 2) J.O. Doali, "The Quantitative Determination of Resorcinol in a Composite-Modified Double-Base Propellant Using High Performance Liquid Chromatography", BRL MR2685 (1976) (limited distribution)

Resorcinol, Derivatives of. See under "Dihydroxybenzene and Derivatives" in Vol 5, D1270-R to D1288-R

Resorcinol, 2,4-Dinitro, Di-Lead Chelate.

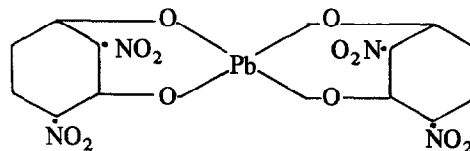

mw 318.19; N 9.55%; OB to CO_2 -100.57%; brn solid; mp, darkens at 137° . Prepn is by heating 2,4-dinitrosoresorcinol with lead acetate. It is v hygroscopic, ie, at 100% RH a wt gain of 10.5% is observed. The chelate has an expl temp of 135° (after 7 mins of heating); an ign temp of 225° (upon rapid heating); an impact sensy comparable to that of TNT; an International Heat Test at 75° of 0.7% wt loss; a power by BalMort of less than 50% of that of TNT; and a thermal stability at 100° of no explns in 300 mins

Refs: 1) Beil - not found 2) R. McGill et al, OSRD 830 (1942), 5

Resorcinol, 5-Methyl, 2,4-Dinitro (2,4-Dinitro-3,5-dioxy-1-methyl-benzene or 2,4-Dinitro Orcinol). $\text{CH}_3\cdot\text{C}_6\text{H}(\text{NO}_2)_2(\text{OH})_2$; mw 214.15; N 13.08%; OB to CO_2 -82.19%; yel leaflets

(from ethanol); mp 164.5°. V sol in eth, sol in hot benz. Prepn is by reacting dinitrosoresorcinol with cold concd nitric acid in a 1 to 4 ratio. The compd explds when heated rapidly
Ref: Beil 6, 890

Resorcinol, 5-Methyl, 2,4,6-Trinitro (2,4,6-Trinitro-3,5-dioxy-1-methyl benzene or *eso*-Trinitro-Orcinol). $(O_2N)_3C_6(OH)_2.CH_3$; mw 259.15; N 16.22%; OB to CO_2 -52.48%; yel ndles; mp 162°, at 163.5° it explds (weakly). V sol in hot w and hot benz. Prepn is by boiling 2,4,5,6-tetranitro-*m*-cresol in w for 7 hrs
Ref: Beil 6, 890

Resorcinol, Trinitro-di(β -nitroxy) Ethyl Ether.
 See under this title in Vol 5, D1288-L

Resorcinol, Trinitro, Explosibility of. See under "Trinitroderivatives of Dihydroxybenzene" in Vol 5, D1277-L

Resorcinol, Trinitro-, (bis) Triethyl Lead. See under "Bis (triethyl) Lead Styphnate" in Vol 2, B160-L
Addnl Ref: Beil 6, {4356}

β -Resorcyate, Lead (Lead-2,4-Dihydroxy benzoic acid). The salt exists in two forms: normal and basic. Both are used in proplnt compns to modify and/or stabilize the rate of proplnt burning (Refs 2, 3 & 4)

Normal (or Dibasic)
 $Pb[O(O)C.C_6H_3(OH)_2]_2$; mw 513.44; OB to CO_2 -77.91%; white powdr; transition pt 160° (loss of w of hydration, Ref 5) and 225°; decompn pt 290° (Ref 6). Sol in ethanol, dimethyl formamide, acet, tetrahydrofuran and dimethyl sulfoxide; sl sol in benz and w. According to Satriana (Ref 6) the dibasic salt is prepd in 92.5% yield by reacting Pb monoxide with β -resorcylic acid in a 1:3 molar ratio in 50% ethanol at RT for five hours under a current of air. The prod is filtered off, washed with ice cold 50% ethanol and oven dried at 100° to constant wt

The normal salt is used in NC proplnt formu-

lations such as those invented by Camp et al (Refs 2 & 3) and Ref 4. The latter contains NC (12.6% N) 48-50, NG 39.7-44.5, propyl di-N-adipate 0.4-3.7, 2-nitro-diphenylamine 2.0, cupric salicylate 2.0-2.5, cupric β -resorcyate 2.5-3.8, *Lead β -resorcyate* 2.0-2.5%, and candelilla wax 0.1 part by wt

A classified US Navy purchase description (Addnl Ref 1) exists for this compd, however, there is no US Mil Spec

Monobasic

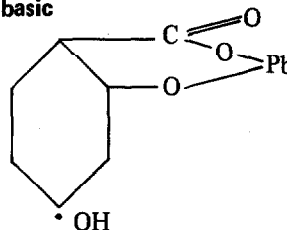

mw 359.31; OB to CO_2 -53.44%; white powdr; mp 225° (decompn). Insol in acet, benz, dimethyl formamide, dimethyl sulfoxide, ethanol and tetrahydrofuran. Again, according to Satriana (Ref 6) the monobasic salt is prepd in 89.5% yield by reacting Pb monoxide with beta resorcylic acid in a 1:2 molar ratio in abs ethanol at 60-70° for 1.5 hrs with constant stirring. The prod is filtered off while warm, washed twice with warm (60°) abs ethanol and then oven dried at 60° for several hrs

The monobasic salt is used in proplnt formulations such as those invented by Camp et al (Ref 3)

No US Mil Spec exists for this compd
Refs: 1) Beil - not found 2) A.T. Camp, USP 3088858 (1963) & CA 59, 6191 (1963) 3) A.T. Camp & F.G. Crescenzo, USP 3138499 (1964) & CA 61, 10528 (1964) 4) Anon, BritP 1168657 (1969) & CA 72, 57358 (1970) 5) D.R. Satriana, "Moisture Sorption of Lead Beta Resorcyate Salts", PATM 2022 (1971) 6) Ibid, "Preparation of Analytically Pure Mono-Dibasic Lead Beta Resorcyate", PATM 2021 (1971)

Addnl Refs: 1) Anon, "Purchase Description: Normal Lead Betaresorcyate", NASC WS1591 (C) 2) R.M. Abbot & N.S. Gelber, "Analysis of Lead and Copper Salts of Hydroxy-Substituted Benzoic Acids", PATR 4376 (1972) (Limited Distribution)

β -Resorcylic Acid. See under "Dihydroxybenzoic Acid and Derivatives" in Vol 5, D1288-R

β -Resorcylic Acid, 3,5-Dinitro. See under "3,5-Dinitro-2,4-dihydroxybenzoic Acid" in Vol 5, D1289-L

α -Resorcylic Acid, 4-Nitro. See under "Nitro-derivatives of Dihydroxybenzoic Acid" in Vol 5, D1289-L

β -Resorcylonitrile, 3,5-Dinitro. See under "2,4-Dihydroxybenzonitrile" in Vol 5, D1289-R

Resorzinat, Bleitritinitro- or Bleistypnmat (Swiss). Lead trinitroresorcinate (or styphnate). According to Stettbacher (Ref 1) it is prepd by adding Na carbonate followed by Pb nitrate to a boiling soln of styphnic acid. The prod is deep orange cryst; d 3.1g/cc

Refs: 1) A. Stettbacher, *SSB*, 1-6 & 21-7 (1937) (Prepn & properties of LSt) 2) Stettbacher (1948), 98

Resorzin, Trinitro- (Swiss), Styphninsäure or Oxypikrinsäure (Ger) (Trinitroresorcic, Styphnic or Oxypicric Acid). A compn manufd during WWII for mil purposes by the Schweiz Sprengstoff-Fabrik A-G, Dottikon

Ref: A. Stettbacher, Private communication (Dec 14, 1953)

Rest Proof. Brit terminology for functioning tests of ammo or its components carried out other than firing from a gun. Same as Static Test

Retene-3-Diazo-4-Oxide, 9-Nitro (1-Methyl-3-diazo-4-oxide-7-isopropyl-9-nitro-phenanthrene).

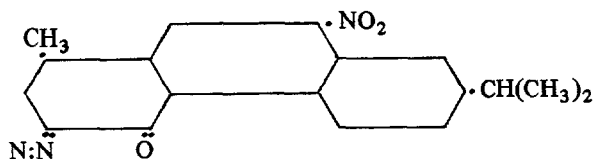

mw 321.36; N 13.08%; OB to CO₂ -199.15%; brick red cryst; mp, explds when heated. Sol in w. Prepn is by reacting a soln of 3-amino-4,9-dinitro retene in warm concd acetic acid with a soln of Na nitrite in concd sulfuric acid. The resulting ppt is washed first with acetic acid, then ethanol and then with eth

Refs: 1) Beil - not found 2) L. Sihlbom, *ActaChemScand* 4, 1554-59 (1950) & *CA* 45, 7093 (1951)

Retonation. A detonation which is delayed in developing, that is it does not start until the shock from a donor, thru a barrier, has proceeded for a distance known as "induction distance", and then the detonation goes not only forward into fresh material, but also backward in the shocked material

Ref: Anon, "Principles of Explosive Behavior", *EngrgDesHndbk*, AMCP 706-180 (1972), 12-15

Retonation Caused by the Reflection of Divergent Waves in Detonation. See Vol 4, D510-L

Retrofit (Retroactive Refit). A modification of equipment to incorporate changes made in later production of similar equipment. Retrofitting may be done in the factory or field

Ref: Anon, *OrdTechTerm* (1962), 256

Revolvers and Self-Loading Pistols. The pistol can be defined as a weapon designed to be fired using only one hand. It exists today in the form of the pistol revolver and the self-loading pistol. Of the two types the pistol revolver is the earlier and the self-loading pistol is, comparatively, a newcomer to the battlefield

Pistol Revolver.

The pistol followed the musket in adopting various forms of ignition that were evolved, developed and subsequently discarded for some new principle or application of an existing system, which offered savings in time or increased assurance of successful functioning.

The earliest pistols were single-barrel weapons; these were followed by cluster barrels - often referred to as *pepper boxes*. The first modern

revolver was probably that of E.H. Collier of Boston, Mass, who obtained an Engl patent in 1818 for a flintlock revolver which had a five-chambered cylinder. The most interesting part of the design was that the cylinder moved forward before the cock fell, and the front of the chamber fitted over the cone-shaped rear end of the barrel in a manner almost identical to that used in the Belg Nagant revolver adopted by the Russ Army in 1895. The method ensured that gas did not escape from the front of the cylinder and so dissipate energy that should have been forcing the bullet up the bore

The development of percussion ignition simplified the design of hand guns. In 1835 Samuel Colt took out an Engl patent for a revolving cylinder weapon with six chambers. A ratchet with six teeth was cut around the head of the cylinder, and as the firer retracted the hammer a metal "hand" rotated the cylinder 1/6th of a revolution (or 60 degrees), and it was then locked. The percussion caps were fitted over hollow nipples and a partition separated the nipples to prevent the flash from one setting off its neighbor

After initial setbacks Colt set up a production line at Hartford, Conn, and from 1853 to 1857 he also manufd single action revolvers in London

The single action revolver requires the firer to cock the hammer by hand between shots. A pull on the trigger releases the hammer which is rotated forward by its compressed spring

The double action pistol enables the firer firstly to cock the hammer and rotate the cylinder and then to release the hammer – all as a result of one long trigger pull. In most designs the weapon can also be thumb-cocked like a single action revolver. The first double action revolver of significance was produced by Beaumont in London in 1855. This could function as either a double action or single action revolver, and the idea was used in the Adams revolver which became the official Brit service revolver. Colt then gave up his Brit factory in 1857 and returned to the USA. His six-chambered percussion 1860 model in .44 cal was extensively used in the American Civil War and more than 200,000 were made

The pin fire revolver saw a brief popularity, and then the rim fire percussion cartridge was



Fig 1 Early Hand Weapons – Colt Cal .45 and .38 Revolvers

evolved by Flobert in Paris. Smith and Wesson, probably second only to Colt in the development of revolvers, bought up the patents held by Rollin White and became the only manufacturer in the USA able to drill the chamber thru to allow insertion of a metal cartridge from the rear

When their patents expired in 1869 a host of other manufacturers produced revolvers but Colt was the most successful, and the solid frame pistol known as the *Single Action Army* was bought in large numbers from the date of its introduction in 1873. This .45 cal revolver, using a metallic cartridge, was a direct descendent of the Colt Model 1860. This revolver had a top strap and spring loaded ejector (Fig 1)

In 1888, the US Navy adopted the Colt .38 revolver which introduced the swing out cylinder – giving the strength of the solid frame and quick loading and unloading (Fig 1), and its adoption by the US Army followed in 1892. The last model of this revolver was brought out in 1903, after the Philippine Insurrection revealed that the .38 failed to halt the Filipino natives before they killed or wounded American troops

The Brit Army adopted the Webley hinged frame in 1894. This had a stirrup-shaped lock which engaged over the barrel stop to produce a very rigid frame. Development of the revolver has subsequently produced no new principles but many small innovations

Self-Loading Pistols.

This type of weapon carries out all the stages of the cycle of operation, except that of firing, using energy which originates from the propellant charge. The trigger must be released and then pulled for each shot fired

The self-loading pistol became possible because of the development in ammo. The production of a strong case, capable of producing total obscuration as well as withstanding not only propellant pressure but the stress of extraction, was the first requirement. Next came the production of propellants able to burn away completely in the first inch or so of bullet travel and lastly the jacketed bullet, firmly crimped into a brass case, which could withstand the shock of loading

When such a cartridge was available the self-loading pistol followed as a matter of course and

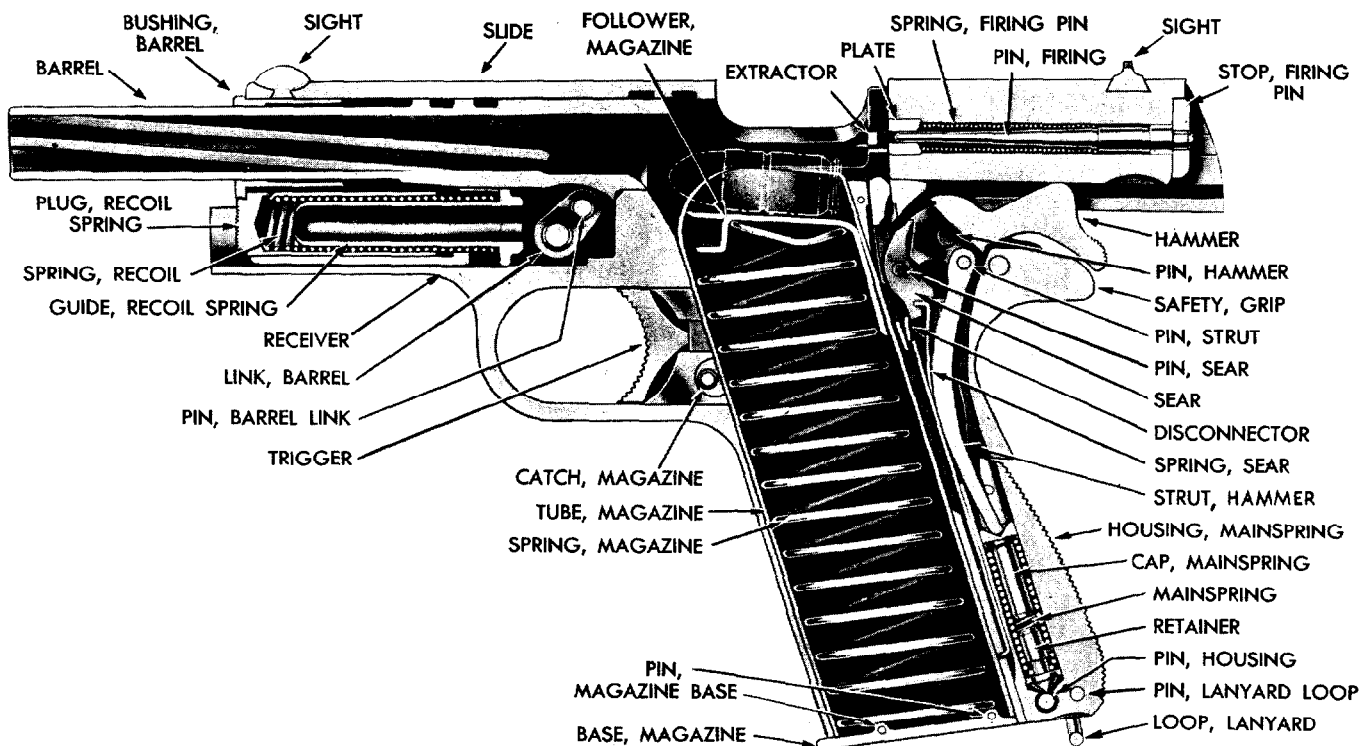

Fig 2 Sectional View of Pistol M1911A1

the first practical example is generally taken to be the Schönberger, made by the Austrian Arms Works at Steyr. This was charger loaded thru the top, like a magazine rifle, and the charger fell out of the bottom of the magazine when the last round was chambered

The Borchardt SL pistol of 1893 was the first pistol to be widely known and this was developed into the Luger which is still made by the Ger firm of Mauser. The cartridge Borchardt developed became the 7.63mm Mauser, which is essentially the same as the 7.62mm "P" ball used by the Soviets for many years in both pistols and sub-machine guns, and are still so employed by the satellite countries

The first Browning pistol was made for Fabrique Nationale d'Armée de Guerre, and a patent granted in 1899. From this start a wide variety of Browning designs have appeared. The current US Army military pistol — the Colt M1911A1 (Fig 2) — stems directly from Browning's early designs

Refs: 1) W.W. Greener, "The Gun and its Development", 9th Ed, Bonanza Books, NY (1910), 44–110, 524–39 2) Anon, "Small Arms Materiel and Associated Equipment", **TM9-2200** (1949) 3) Anon, "Fundamentals of Small Arms", **TM9-2205** (1952) 4) D.B. McLean, "U.S. Pistols and Revolvers", Normount Technical Publications, Wickenburg, Ariz (1966) 5) F.W.A. Hobart, "Jane's Infantry Weapons—1975", Franklin Watts, NY (1974), 34–118

Reworking of Explosives and Propellants. See under "Recovery and Recycling of Energetic Material from Ammunition" in this Vol

Rexite. A Brit permitted mining expl contg TNT 6.5–8.5, NG 6.5–8.5, AN 64–68, Na nitrate 13–16, woodmeal 3–5, and moisture 0.5–1.5%

Ref: Colver (1918), 249

Rex Powder. A Brit permitted mining expl contg NG 11.0–13.0, AN 58.0–61.0, woodmeal dried at 100° & Na chloride 18.5–20.5%

Refs: 1) Daniel (1902), 392 & 681 2) Naoúm, NG (1928), 444

Reynolds Powder. A white powder which ignited more easily than BlkPdr. It consisted of "chlorate of cotton" 75 and "sulfoarea", $CS(NH_2)_2$, 25%. The latter component was obtained as a by-product in the fabrication of illuminating gas. See also under "Chlorate Explosives" in Vol 2, C206-L

Ref: Daniel (1902), 681

RF Energy, Effect on Weapon Systems. Ref 1 discusses how to protect expls and related items against electrical hazards. The components used for control, timing, sensing, initiation, and other functions in most of the modern weapon systems are electrical in nature. Power to operate the systems is supplied from electric sources, and the expl components which are used to perform a multitude of functions are electroexplosive devices (EED's) (see Vol 5, E63 ff), which are electrically initiated. While many advantages have been gained by the use of these systems, EED's are susceptible to malfunction and degradation as a result of spurious electric signals if the systems and components are not properly protected

The combined natural and man-made environment which can serve as a source of these spurious signals is at an all-time high and is still increasing. As a result, the engineer designing a weapon system must not only consider the effects of such natural phenomena as lightning and electrostatic charge, but also man-made electrical sources such as unwanted circuit transients and radio frequency originating from communication equipment, radars, transmitters associated with weapon systems, and nuclear expls. System effects produced by these electrical environments can vary from partial failures of components resulting in changes in their characteristics so that they no longer function properly at their design levels, to complete "dudding" of components resulting in a failure to operate under any conditions. In the case of the EED it is possible to have premature initiation, frequently resulting in cataclysmic failure of the system. Furthermore, failures may be produced by spurious signals appearing in portions of the components not considered part of the normal path

Refs: 1) Anon, EngrgDesHndbk, "Hardening

Weapon Systems Against RF Energy", **AMCP 706-235** (1972) 2) G. Cohn, Ed, Expls & Pyrots 9 (9), Sept 1976 (Review of Ref 1)

Rhamnose (L-Rhamnose, 6-Deoxy-l-mannose, L-Mannomethylose or Isoldulcitol).

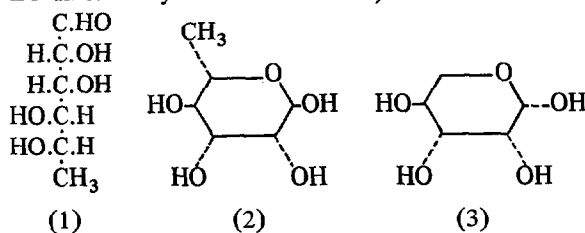

The compd exists in nature as a tautomeric mixt of two forms; α and β . Structure (1) represents the mixt while structure (2) is α and structure (3) represents the β isomer; $\text{C}_6\text{H}_{12}\text{O}_5$; mw 164.16; white crystals; mp 101° (α -form from ethanol), the α -form converts partially to the β -form on heating, the β -form melts at $114-16^\circ$ (other values detd for the β -form are $123.5-124.5^\circ$ and $127-129^\circ$); bp 105° at 2mm (α -form which subl); d 1.4708 g/cc at $20/4^\circ$ (α -form). Both of the forms and the mixt are v sol in methanol and w; sol in ethanol; the β -form is sol in hot acet

The racemic mixt occurs free in poison sumac and is combined in the form of glycosides of many plants. It can be prepd by boiling xanthorhamnin with dil sulfuric acid, filtering off the solids formed and saturating the filtrate with Ba carbonate so as to form a syrup from which the l-rhamnose crystallizes. The prod is purified by extraction with ethanol and recrystn (Ref 2). The α -form is obt'd from the racemic mixt by crystn from a hot ethanol soln. The β -form is prepd by heating α -rhamnose monohydrate on a steam bath and then crystg it from an anhyd acet and ethanol mixt (Refs 4 & 5)

Refs: 1) Beil 1, 870, (439) & (4261) 2) Ibid 31, 65 3) ChemRubHdb (1975), C-486 4) Merck (1976), 1060; No 7963 5) Cond-ChemDict (1976), 752

There are two rhamnose nitrates of interest which are presented below:

L-Rhamnose Trinitrate. $\text{C}_6\text{H}_9\text{O}_5(\text{NO}_2)_3$; mw 299.18; N 14.05%; OB to CO_2 -29.41%; amor solid; mp below 100° . V sol in ethanol; insol in w. Prepn is by adding l-rhamnose to a nitric-

sulfuric acid mixt. The compd explds when struck with a hammer

Ref: Beil 31, 70

L-Rhamnose Tetranitrate. $\text{C}_6\text{H}_8\text{O}_5(\text{NO}_2)_4$; mw 344.18; N 16.28%; OB to CO_2 -13.95%; coarse rod-like cryst (from ethanol or acet acid); mp 135° (vigorous decompn). V sol in acet, acetic acid and methyl alc. Prepn is by dropwise addn of concd sulfuric acid to a soln of l-rhamnose in concd nitric acid at 0°

Ref: Beil 31, 70

Rheinbote (Ger for Rhine Messenger). An unguided three stage and booster surface-to-surface missile, developed in 1943 by the Rheinmetall-Borsig Co under the direction of Klein and Vüllers. It contained 45 lbs of HE, used 1287 lbs of a solid DEGDN proplnt, was provided with a six-finned booster, and could be launched from a stationary or mobile ramp. The total wt of the rocket was 3781 lbs, and overall length 37.4 ft. Its max range, using a 65° elevation launch angle, was 136 miles, and velocity with the final stage was 5380ft/sec

Refs: 1) K.W. Gatlan, "Development of the Guided Missile", Flight Publication, London (1952), 55 & 122-23 2) W. Dornberger, "V-2", Viking, NY (1954), 248

Rheinische Dynamit. A Dynamite patented in 1874 consisting of NG (contg 2-3% of dissolved hydrocarbons such as naphthalene) 75, washed and dried kieselguhr 23, and chalk 2%

Ref: Daniel (1902), 682

Rheintochter (Ger for Daughter of the Rhine). A type of guided missile used against England during WWII. Several models were known, such as R-1, R-2 and R-3

Refs: 1) Anon, ArmyOrdn 31, 28 (1946) 2) A. Ducrocq, "Les Armes Secrètes Allemandes", Paris (1947), 89-90 & 96-98 3) Anon, **TM9-1985-2** (1953), 226-29

Rhexite. An expl proposed by Diller at the end of the last century and manuf'd in Austria and Hungary. Its compn was NG 64-67, Na nitrate

18, woodmeal 4-7, and partially decompd wood 11%. Its properties were: d 1.54g/cc, Trauzl test value 385cc; OB -11%; and Pb block crushing value 20mm

Refs: 1) Daniel (1902), 683 2) Naoúm, NG (1928), 284

Rhonit. Swiss plastic HE manufd at Gamsen. Its compn is identical to that of **Argonit** (see Vol 1, A480-R)

Ref: Private communication from Dr. A. Stettbacher, Zurich, to Dr. B.T. Fedoroff, 23 Aug 1958

Ricinolein (Glycerintriricinoleate or Triricinolein). $\{CH_3 \cdot [CH_2]_5 \cdot CH(OH) \cdot CH_2 \cdot CH:CH[CH_2]_7 \cdot CO.O\}_3 C_3 H_5$; mw 933.04; colorl, neutral oil; d 0.9618g/cc at 29°; RI 1.4763 at 29°. V sol in benz, chl and eth; v sl sol in ethanol, methanol, ligr and CS₂. Prepn is by heating K ricinoleate with glycerin trichlorohydrin in a stream of hydrogen

Ref: Beil 3, 388, (139), [259] & {711}

Note: For information on *ricinoleic acid*, see Vol 2, C87-R to C88-R under "Castor Oil, Hydrogenated" and "Castor Oil, Nitrated"

Ricinolein Nitrate (or Nitricinolein). Obtd by nitration of ricinolein and used with NC (1/9 p) as an expl component

Refs: 1) Beil, not found 2) Daniel (1902), 670

Ricker and Spence Powders. Blasting expls based on K chlorate patented in Engl in 1862 by Ricker and Spence. Other ingredients could include K, Na or Pb nitrates, charcoal, algae (partly calcined), Na bicarbonate, wheat flour, pulverized bark and dried coffee residues

See also under this title in Vol 2, C206-L
Ref: Daniel (1902), 683

Rickmers' Explosives. A mixture of myrobalans (dried fruits of Terminalia contg 30% tannin) with oxidizers such as Amm perchlorate, AN, K nitrate, etc. A typical formulation contained myrobalans 36, Amm perchlorate 36, K nitrate 28%, with a small amt of a binder such as agar-agar

Refs: 1) W. Rickmers, USP 896325 (1908) & CA 2, 3283 (1908) 2) Ibid, BritP 10510 (1907) & CA 3, 839 (1909)

RIDE. Acronym for **RDX-Insensitive-Demolition-Explosive**. A US plastic high expl developed at PicArns subsequent to WWII consisting of:

RDX (Specification Material), %	77.0
Barium Nitrate (100% thru 120 mesh sieve, Specification Material), %	15.0
Uni-Temp Grease, %	5.8
Polyisobutylene (mw 120,000), %	2.2

Its sensitivity, stability and performance properties are detailed below:

Density, g/cc.	1.49
Explosion Temp, °C.	285
	(to smoke in 5.0 secs, no expln or flash)

Hygroscopicity (90% RH, 30°).

% Gain in wt in 75 hrs	0.02
------------------------	------

Pendulum Friction Test, Steel Shoe.

Number of trials	10
Unaffected	10

100°C Heat Test.

% Loss in 1st 48 hrs	0.07
% Loss in 2nd 48 hrs	0.05
Explosion in 100 hrs	none

Plate Dent Test.

Block (Engineer Corps Special Blasting Cap used for initiation), dent, inches	0.089
---	-------

Cylinder (35g Tetryl Booster plus Engineer Corps Special Blasting Cap used for initiation), dent, inches	0.197
--	-------

Rate of Detonation, m/sec.	6850
----------------------------	------

Rifle Bullet Impact Test.

Number Trials	5
Partial Detonation	0
Burned	1
Unaffected	4

Impact Test, 2kg wt.

PicArns App, inches	15
---------------------	----

Sand Test.

Sand Crushed, g	47.1
Min Det Charge:	
Tetryl, g	0.10
LA, g	0.20

Specification Deton Test (JAN-C-427).

Number Trials	5
---------------	---

Number Failures	0
Entry Diameter, mm	2.73
Exit Diameter, mm	1.92
<i>120° Vacuum Stability Test.</i>	
CC gas in 40 hrs	0.73

Among the principle plastic US high expls developed during WWII were RDX Composition C-3 (see Vol 3, C484-L to C488-R), RIPE (qv in this Vol) and PEP-3 (qv in Vol 8). While all were of satisfactory chemical and thermal stability, none possessed the important property of remaining essentially unchanged in physical characteristics over a range of temps from -65°F to $+169^{\circ}\text{F}$. None remained plastic at -65°F . RDX Composition C-3 and PEP-3 exuded badly at only slightly elevated temps, while exudation in the case of RIPE was not as marked. In all cases of exudation, the residue was generally more sensitive than the initial expl

An extensive study of the physical and chemical stability, sensitivity and compatibility characteristics of these expls was made at Pic-Arsn. As a result of this study, it was concluded that none of these expls possessed sufficiently promising characteristics to warrant attempt at improvement by simple modification

It was realized that work should be undertaken to develop an improved plastic high expl. Several score of exptl plastic expl compns were prepd and studied using RDX as the sole expl ingredient, together with different inert materials as binders. RIDE was indicated to be generally superior to Composition C-3. It could be molded at -65°F and did not exude at $+169^{\circ}\text{F}$. It was thermally stable and insensitive to friction, impact and rifle bullet fire. Tests indicated that it performed as well at -65°F as at normal atm temp. However, its brisance (as measured by Plate Dent Tests) was indicated to be less than that of Composition C-3, but greater than that of RIPE. It was concluded that RIDE was indicated to be a suitable replacement for Composition C-3

Ref: L.H. Eriksen & R.C. Grass, "Plastic Explosives — Development of an RDX Plastic Explosive of the C-3 Type", PATR 1713 (1949)

Rifle. The main personal weapon of the infantry, which fires a small-diameter elongated bullet thru a rifled barrel, propelled by smokeless

powder held in a metal cartridge

The first record of an infantry gun appears about 1364. It was known as a *cannon-lock* because it was in all aspects a small cannon mounted on a stave and was carried by a single soldier. The word "lock" refers to the means of ignition and here a burning ember, and later on a slow match, was applied to a touch-hole at the rear in the same way as to a cannon of the time

It was not until the end of the 15th century that the *match-lock* appeared. With this type of weapon the iron barrel was attached to a wooden stock that rested on the firer's chest and the burning slow match was held in an S-shaped holder with the lower end acting as a trigger. Pulling the trigger lowered the smouldering match into the powder priming and this set off the main proplnt charge. This type of weapon is often called an *arquebus* (see Vol 1, A488-L). It produced a very slow rate of fire. Before re-loading, the burning match had to be removed from the serpentine and the powder could then be measured out and poured into the muzzle. The over charge wad was then inserted followed by the ball, and another retaining wad. The ram rod was then used to consolidate these elements and the priming pan replenished with gunpowder and protected, in many guns, by placing a cover over it. The match was replaced in the serpentine and all was ready for another shot

The situation improved with the introduction of the *wheel-lock* (Fig 1), which produced its own fire by mechanical action, in the early 16th century. This name was used because of the prominent wheel which was rotated to produce fire. In addition to the wheel, the mechanism consisted essentially of the cock, the mainspring, and the sear. The wheel was serrated to provide a rough surface. The cock was a clamp which held a small piece of iron pyrites. Iron pyrites is a mineral which, when rubbed against a roughened piece of metal, will produce sparks

For firing the weapon, the wheel was would by a large key or wrench. Winding of the wheel placed the main spring under stress, in which position it was retained as the sear fell into a small hole in the side of the wheel. After placing the main charge and the bullet in the barrel of the gun, a small amount of powder was poured into the priming pan over the wheel and the cock

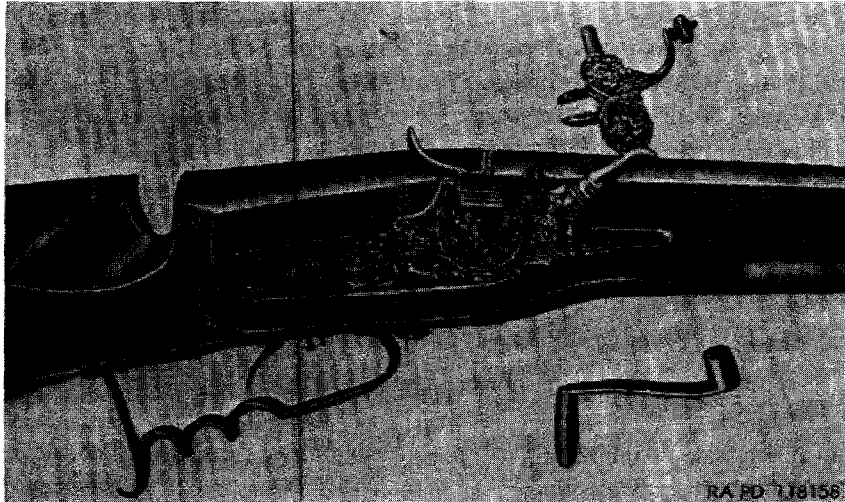

Fig 1 Mechanism of a Wheel Lock and Key for Winding It

was let down to bear against the wheel. When the sear was withdrawn from the wheel by pressing on the trigger, the wheel rotated rapidly and, because it rubbed against the pyrites, a shower of sparks was produced. The space around the wheel was filled with priming powder which caught fire from the sparks and, in turn, ignited the main charge in the gun. This type of lock was very heavy and its military use was confined mostly to wall guns. It was also used for sporting purposes but did not find favor in this application because of its weight and the time required for it to ignite the charge

At this early period of its history, the shoulder rifle was already composed of all fundamental elements necessary to aim and fire it. The list of these three elements is still used as a figure of speech to express a complete package – lock, stock, and barrel

Although development and use of the wheel lock continued until the middle of the 17th century, there was great need for a weapon which would be lighter and more reliable in action. This need led to the development of a gun lock in which the fire was produced by striking two substances together, rather than by rubbing them. This type of lock is commonly known as a *flintlock*; historically, several steps in its development can be pointed out. An early type was known as a snaphance or snaphaunce. In this weapon, the pyrites was replaced by a flint and the action was constructed so that,

when the trigger was pulled, the flint struck against a sloping piece of iron, known as the frizzen, causing a shower of sparks to fall against the powder in the pan. With this type of action, it was necessary to open the pan cover and to cock the hammer by hand before firing

At some time before the year 1700, a method was found of combining the pan cover and the frizzen into an assembly called the battery. The battery was constructed to cover the pan before firing, thus protecting the priming powder from rain or fog and requiring only one motion, that of cocking the hammer, to make the piece ready to fire. When the trigger of the flintlock was pulled, the striking action of the flint against the battery opened it and at the same time directed the shower of sparks into the priming powder. This type of lock was so reliable that it was adopted and used with a few changes in Brit military muskets from the early 18th century until approx 1850, at which time it was superseded by the percussion lock. It is sometimes stated that the Brit Army used the same musket thruout this entire period. This statement is, however, incorrect as at least three different types of standard muskets, using very similar types of flintlock mechanisms, can be distinguished

While efforts were made to improve the firing mechanism of the gun, development work was also being carried out to improve accuracy and reliability. A bullet fired from a smooth bored

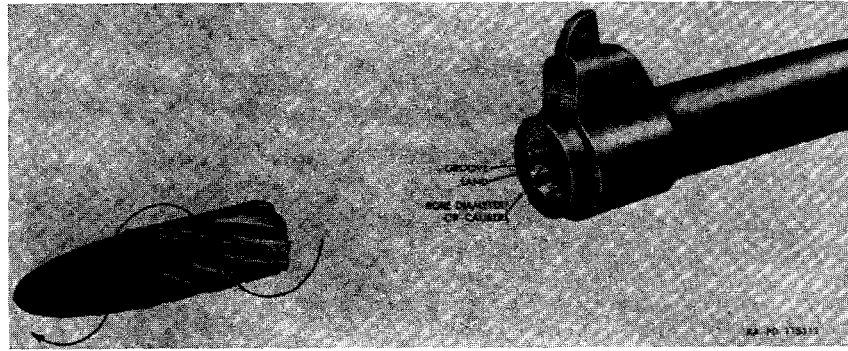

Fig 2 Bullet Spun by Rifling

gun rebounds from side to side of the barrel during its passage, and the direction of its final flight is largely determined by the side of the barrel which it struck last before leaving it. Attempts were made to control the phenomenon by bending the barrel slightly at the muzzle, assuring that the bullet would always strike the same side, but this method was inaccurate, as the bullet would "roll along" in its flight rather than "spin"

It was found thru experience that the accuracy of firing could be controlled by rotating the bullet as it was fired. German, Italian, and Swiss gunsmiths, in the 16th century, had discovered that they could engrave shallow grooves, called rifling, in the bore of the barrel. These grooves twisted from one end of the barrel to the other. If the bullet was such a tight fit that it would be forced into the grooves while passing thru the barrel, then it would spin about the axis of the barrel during flight, as shown in Fig 2, and the weapon would be relatively accurate

At the time of the invention of rifling, there were several practical difficulties against its general adoption. Principal among these were corrosion and clogging of the bore caused by powder fouling. After gunpowder is burned, the solid residue which adheres to the gun barrel offers a good place for the accumulation of moisture and consequent corrosion. To overcome this difficulty, it was necessary to make the rifling grooves so deep that the bullet did not fit the bore tightly and, as a result, a large amount of gas was lost by leakage or "blow by" around it

The more progressive military forces adopted rifled weapons because they were more accurate

than unrifled ones. The rifled weapons were also adopted for hunting and sporting. During the American Revolution, the American rifles proved superior to the Brit unrifled muskets. The Brit tried to overcome this superiority by employing Ger Jagers (hunters) who were armed with rifles

The 19th century has been called "The Golden Age of Science". Like many other fields of scientific and technical development, weapons were greatly improved and changed during these 100 years. Many problems which had beset designers and soldiers alike were successfully solved. First of these was the problem of satisfactory ignition of the powder charge under adverse conditions. The first big advance in this direction was the development of a percussion primer by Rev Alexander J. Forsyth in 1807. His discovery of a fulminating mixt which would produce fire when struck by a hammer was revolutionary in that it represented the first appearance of a chemical method of ignition but it was not until 32 years later, in 1839, that the first percussion rifle was adopted as a military weapon in Great Britain. The first US percussion musket was made about 1842

The problem of improving accuracy was more difficult and was not successfully solved until the middle of the century. Earlier, in the 18th century, an improvement known as the Baker rifle had been made. This gun used a spherical bullet, cast with a band or belt extending completely around it. The rifle had two rifling grooves. The bullet was rammed down the barrel from the muzzle, with the band engaged in the two grooves of the rifling. By this means, it was possible to use a bullet small enough to be

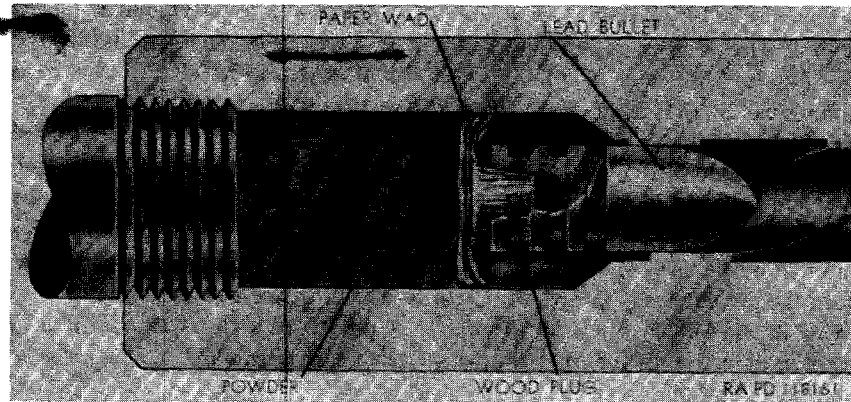

Fig 3 Expanding Bullet as Loaded in Gun

easily rammed down the barrel and yet of a good fit in the rifling grooves. This method was only partially successful because gradual accumulation of powder fouling in the grooves and bore soon closed them and made it impossible to insert additional bullets. Subsequent improvements were made by designing the chamber smaller than the bore or by providing an obstruction against which the bullet could be forced by means of the loading mallet or ramrod. This development was initiated by Captain Delvigne in 1826 and was brought to a successful conclusion by Captain Minie of the Fr Army in 1850. Minie's inventions consisted of placing a small conical wooden plug in the hollow base of an elongated lead bullet (Fig 3). The bullet was forced down the bore and came to rest on the powder charge. The pressure of the gas expanded the bullet so that, when it was driven out by the burning gunpowder, it was rotated by the grooves of the rifling. This invention enabled the bullets to be made considerably smaller than the bore so that a larger amount of powder fouling could accumulate before cleaning of the gun was absolutely necessary to permit further use

The muzzle loading rifle always had one serious drawback for military purposes. When loading it, the soldier was required to extend his right arm fully, often exposing it to enemy fire. The problem of designing a successful breech loading gun was complicated by the high pressures required and the necessity for sealing these pressures by a mechanism which would be simple to operate and easy to manuf. This development was not satisfactorily achieved

until after the invention of the brass cartridge case, although a considerable measure of success was obtained by Christian Sharps, who made a slidingblock action which operated with a paper cartridge case. The performance of Sharps' rifle would have been unsatisfactory had it not been for his manufg methods, many years in advance of his time, which made it possible to manuf all the parts to extremely small tolerances. The development of the *needle gun* by Dreyse in Prussia, about 1848, was a significant step in the development of breech loading firearms. This gun was so named because of the long needle-shaped firing pin which was thrust entirely thru the powder charge to strike and ignite the primer placed at the front end of the charge near the bullet

The bolt-action principle was rapidly adopted by many nations at the end of the 19th century. Outstanding military weapons of this type are the Mauser and Springfield rifles, brought to a high state of perfection in the early years of the 20th century and since used thruout the world

The beginning of the 20th century was marked by the final development of standard service rifles of the US cal .30 M1903 bolt action type. At that time, many nations were armed with weapons of similar design. Each weighed about 9 lbs, had a barrel 24 inches long, and was a bolt action breech loader. A large number were made in cal 7.92mm (0.312 inch), but they ranged in size down to 7mm (0.256 inch)

In 1912, Colonel Mondragon, in Mexico, developed an automatic rifle which was rather heavy but functioned in a satisfactory manner,

and was subsequently adopted by the Ger Army and used during WWI. However, most nations entered WWII with bolt action rifles. The US Army had the Garand (cal .30 M1) which was a gas operated 8-shot SL rifle and this led the way. The Russians had the Simonov and Tokarev SL rifles. The 7.62mm Tokarev was made in quantity but was not very successful. The Ger developed a semi-automatic rifle in 1941 and later in the war produced the revolutionary concept of the *Assault Rifle* (MP43 and MP44), but most of the Ger armies were equipped with the Mauser bolt action rifle developed in 1898

After WWII, both the Brit and Russ took up the idea of an automatic rifle firing a reduced-power bullet, on the assumption that 500 yds was the max range that the infantry could actually use and that anything more powerful than an "intermediate" cartridge was wasted in a personal hand-held weapon. The Brit developed EM-2, a general multipurpose rifle with a short .28 inch 120 grain cartridge to go with it. This had to be abandoned when the NATO standard 7.62mm cartridge was imposed for rifles. The US later adopted a tiny 0.223 inch cartridge of only 55 grains which produces high muzzle velocity (3300 fps vs 2800 for the NATO cartridge) and a low total muzzle energy (1328 ft lbs vs 2150). A variety of weapons were developed by the designers of the 0.223 inch cartridge, but eventually the M16 rifle was adopted. It permits accurate hand-held fire at up to 500 yds, while in a tripod-mounted medium machine gun version the cartridge is effective up to 800 yds. This is less than full rifle power but just as good for most uses, and the Vietnam war led to the gradual shift of the US Army and Marines to the new, small, light and ultra-fast bullet

Note: See also under "History of Development of Military Detonators, Igniters, Primers and of Other Initiating Devices" in Vol 4, D753-R to D756-L

Refs: 1) W.W. Greener, "The Gun And Its Development", 9th Ed, Bonanza Books, NY (1910), 701-27 2) J.R. Newman, "The Tools of War", Doubleday, Doran, NY (1943), 32-51 3) Anon, "Fundamentals of Small Arms", TM9-2205 (1952), 3-17 4) E. Luttwak, "A Dictionary of Modern War", Harper & Row, NY (1971), 165-66 5) F.W.A. Hobart, Ed, "Jane's Infantry Weapons-1975", Franklin Watts, NY (1974), 178-354

Rifle Bullet Impact Sensitivity (Rifle Bullet Impact Test). See under "Bullet Tests" in Vol 2, B332-L to B340-R

Rifleite. A completely gelatinized smokeless powder first manufd in 1890 in Engl by the Smokeless Powder Co, Ltd, Barwick. It was in the form of flakes. A variety was also introduced for use in shot-guns and was called Shot-Gun Rifleite; this was a 37-grain gelatinized dense powder

Table 1
Rifleite Formulations

	Shot-Gun Rifleite	For .303 Cal Rifle
<i>Date of Introduction</i>	1894	1890
Nitrocellulose, insol, %	76.0	1.7
Nitrocellulose, sol, %	18.9	82.5
Nitro-compound, %	3.5	14.8
Moisture, %	1.6	1.0

The NC was prepd from lignin
Refs: 1) Daniel (1902), 685 2) Marshall, Dict (1920), 81

Rifle Powder of Muraour (Fr). A cool burning proplnt consisting of collodion cotton (N 11.7%) 67, DEGDN 22, sym centralite 9 and K sulfate 2%

Ref: Stettbacher (1948), 44

Rifling. The helical grooves cut in the bore of a rifled gun tube, beginning at the front face of the gun chamber and extending to the muzzle; also, the operation of forming the grooves in the gun tube. The purpose of rifling is to impart spin to the projectile; if the spin is fast enough, the projectile will be gyroscopically stable and will travel approx nose first. It also prevents the escape of proplnt gas around the projectile (as was always observed in smooth-bore weapons), thus increasing the range

Engagement of the projectile with the rifling is generally accomplished by use of a *rotating band* on projectiles greater than about 0.60 inch in diameter, and on smaller projectiles, by providing a soft bullet or, if a hard cored pro-

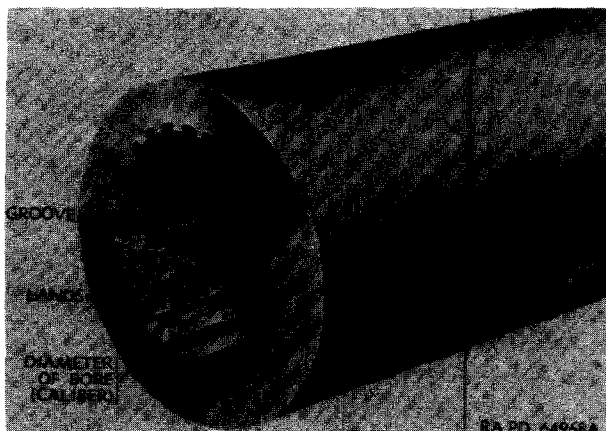

Fig 1 Rifling Details

jectile is necessary, by the use of a relatively soft jacket

The gun bore diameter is determined by the ridges between the rifling grooves. These ridges are referred to collectively as the *lands*, and the sides of the lands are called *edges* (Fig 1)

When the projectile or bullet starts to move under the force exerted by the propellant gases the rotating band or jacket is *engraved* by the rifling which forms a reverse replica in the band or jacket. This *engraving* is accomplished partly by cutting and partly by forming. The metal from the band or jacket projecting into the groove prevents the escape of gas past the projectile

In *recoilless ammunition* the force required to accomplish engraving of the band would interfere with accomplishment of the recoilless feature, and the projectiles for this ammo are *preengraved*; that is, the grooves corresponding to the rifling are made in the rotating band at the time of manufacture. Provision is made to insure that the projectile will be inserted in the recoilless rifle in proper relationship to the rifling

The *twist of rifling* is the reciprocal of the *lead of rifling*; it is expressed as the number of calibers of length in which the helix makes one complete turn; eg, 1 turn in 40 calibers or 1/40. The *inclination* of the rifling is the tangent of the *angle of rifling*, which is the angle between the axis of the bore and the edge of a land; the inclination is π times the lead

In *uniform twist*, the degree of twist is constant from the origin of rifling to the muzzle. In *increasing twist*, the degree of twist increases

from zero or some small value, for example, 1 turn in 50 calibers at the origin, to a sharper twist at the muzzle, such as 1 turn in 25 calibers. The rate of increase may be uniform or become more rapid

Refs: 1) E. McFarland, "Textbook of Ordnance and Gunnery", J. Wiley, NY (1932) 2) Hayes (1938), 194–200 3) Anon, "Principles of Artillery Weapons", TM9-3305-1 (1956), 27–28 4) Anon, OrdnTechTerm (1962), 257–58

Rimfire Cartridge. A small arms cartridge having the primer mixt in the rim of the cartridge case base. The name comes from the method of firing which is by use of an eccentric striker which crushes the primer mixt between the case walls and the rim, thus igniting it and the propellant. Rimfire cartridges were developed in the early to middle 1850's. *Centerfire* cartridges, in forms similar to those we are now familiar with, were introduced during the American Civil War period. It was not until 1866, however, that a separate primer centerfire cartridge which could be reloaded was standardized for the US Army

Refs: 1) Ohart (1946), 79 2) Anon, OrdnTechTerm (1962), 258-R 3) Anon, EngrgDes-Hndbk, "Elements of Armament Engineering, Part Three, Weapon Systems and Components", AMCP 706-108 (1963), 11-3 4) S. Fordham, "High Explosives and Propellants", Pergamon Press, NY (1966), 199–200

Rinkenbach, William H. (1894–1965). American chemist specializing in explosives; holder of numerous patents on explosives and chemical processes. Worked for the DuPont Co, the US Bureau of Mines and Picatinny Arsenal, Dover, NJ. Author of section on explosives in Kirk & Othmer's, "Encyclopedia of Chemical Technology"

Refs: 1) Marquis', "Who's Who in America", 33, Chicago (1964–65), 1684 2) Anon, The Morning Call, Allentown (June 30, 1965) 3) Anon, The Newark News (July 2, 1965)

Riot Control, Chemical Agents for. Irritants, which affect the mucous membranes of the eyes and the respiratory system, are used in riot control to disperse crowds. Chloroacetophenone

(CN) (Ref 2, pp 33–34) has long been an effective tear gas (lacrimator) and lends itself to dissemination by heat when mixed with sugar, K chlorate, K bicarbonate, and diatomaceous earth as in the *M7A1 Tear (CN) Hand Grenade* (Ref 1, p 34). The effect of CN can be enhanced and prolonged by mixing with the vomiting and sneezing agent (sternutator) diphenylamino-chloroarsine or Adamsite (DM) (Ref 2, p 32), as used in the *M6 Irritant Hand Grenade, CN-DM*. In this application, smokeless powder is employed as the heat and propellant source, and MgO as a diluent (Ref 1, p 31)

These agents have been replaced by the compound o-chlorobenzalmalononitrile (CS) (Ref 2, p 37), as in the *M7A3 Tear Hand Grenade, CS*. Because of its sensitivity to decomposition, this material is mixed with sugar and a little wax and w, compressed in pellet form, coated with sugar syrup, and dried. The pellets are then embedded in a modified chlorate/sugar compound. In another procedure, the powdered CS is enclosed in gelatin capsules, which are admixed to the same or a similar heat powder combination

Irritants can also be dispersed by explosion force, as in the plastic (to avoid lethal fragments) baseball-sized *M25 Riot Hand Grenades* (Ref 1, p 36) which are filled with CN or CS

The above-mentioned agents, while unpleasant in even minute concentration and extremely distressing in larger doses, generally leave no lasting after-effects. Soon after removal from the contaminated atmosphere, recovery from the effects of CS is prompt and complete. But as little as 1 mg of CS per cubic meter of air will irritate the eye. This is less than one-thousandth and perhaps as little as one ten-thousandth of the threshold value for chlorine or sulfur dioxide (Ref 3)

Refs: 1) Anon, "Ground Chemical Munitions", **TM3-300** (1956) 2) Anon, "Military Chemistry and Chemical Agents", **TM3-215** (1963) 3) Ellern (1968), 161–62

RIPE. A plastic demolition explosion consisting of a mechanical mixture of RDX (85%) and Gulf Crown E Oil (15%), developed at Picard during WWII

Its sensitivity, stability and performance properties are detailed below:

Density, g/cc (hand tamped) 1.37

<i>Explosion Temp, °C.</i>	Decomps, no value obtained
<i>Hygroscopicity (90% RH, 30°)</i>	
% Gain in wt in 200 hrs	0.04
<i>Impact Sensitivity (2 kg wt)</i>	
BuMines app, 20mg sample, cm	53
PicArns app, 85mg sample, inches	13
<i>Friction Pendulum Test</i>	
Steel Shoe	Unaffected
Fiber Shoe	Unaffected
<i>100°C Heat Test</i>	
% Loss in 1st 48 hrs	0.03
% Loss in 2nd 48 hrs	0.04
Explosion in 100 hrs	None
<i>Ballistic Mortar (% TNT)</i>	118
<i>Detonation Rate</i>	
Confinement	None
Condition	Hand tamped
Charge Diameter, inch	1.0
Density, g/cc	1.37
Rate, m/second	7390
<i>Rifle Bullet Impact Test</i>	
Number of trials	5
Unaffected	5
<i>Vacuum Stability Test</i>	
cc/40 hrs at	
100°C	0.34
120°C	0.56
<i>Sand Test, 200gm</i>	
Sand crushed, gm (TNT=44.1)	40.1
<i>Plate Dent Test</i>	
Brisance, % TNT	85
<i>Exudation</i>	
At 85°C in 30 hrs	None
At 95°C in 48 hrs	None
At 105°C in 48 hrs	Exudes
<i>Note:</i> See commentary on RIPE under article on "RIPE" in this Vol	
<i>Refs:</i> 1) S. Livingston, "Properties of Explosives RIPE, PIPE and PEP-3" PATR 1517 (1945)	
2) S. Livingston & S. Fleischnick, "Plastic Explosives—Comprehensive Study of the Plastic Explosives RIPE, PEP-3 and Composition C-3", PATR 1695 (1948) 3) L.H. Eriksen & R.C. Grass, "Development of an RDX Plastic Explosive of the C-3 Type", PATR 1713 (1949)	
4) Anon, <i>EngrgDesHndbk</i> , "Explosives Series, Properties of Explosives of Military Interest", AMCP 706-177 (1971), 318–19	

Ripping Ammonal. A Brit Ammonal which passed the Woolwich test. It consisted of AN 84–87, Al 7–9, charcoal 2–3, K bichromate 3–4, and moisture 0–1%

Note: See under "Ammonal" in Vol 1, A287-L to A293-L

Ref: Marshall 1 (1917), 393

Rippite. A Brit permitted expl contg NG 59.5–62.5, NC 3.5–4.5, K nitrate 18.0–20.0, woodmeal 3.5–5.5, amm oxalate 9.0–11.0, and castor oil (0.5–1.5%)

Refs: 1) Marshall, Dict (1920), 81 2) Naoúm, NG (1928), 409

Riplene. See under "Boyd Powders" in Vol 2, B259-L

Rivets, Explosive. See under "Explosive Rivets or Other Fastening Devices" in Vol 6, E442-R to E445-L

RLG Powder (Rifled Large Grain). Brit large grain BlkPdr used at the end of the 19th century in rifled ordnance

Refs: 1) Cundill (1889) 2) Daniel (1902), 686 3) Marshall, Dict (1920), 80

Robandis Powder (Brise-rocs in Fr). An early Fr blasting expl contg K nitrate 55.6, Na nitrate 15.7, sulfur 11.9, spent tannin bark or sawdust 11.9, charcoal 3.9 and Na chloride 1.0%

Ref: Daniel (1902), 686

Robert's Powder. An expl patented in Engl in 1873, prepd by blending slightly wetted (with w-glycerin) K chlorate, sugar, and K ferrocyanide, and left in the form of a paste, thus markedly reducing its handling hazard

Note: See under "Chlorate Explosives" in Vol 2, C206-L

Ref: Daniel (1902), 686

Robertson, Sir Robert (1869–1949). Brit scientist, an expert of world-wide repute in the field of expls. His many contributions are detailed in the ref

Ref: R.C. Farmer, JCS 1950, 434–40 (Obituary) & CA 44, 7101 (1950)

Robin Hood Powder Company. An American company located in St Albans, Vermont, which patented [BritP 14525 (1901)] one of the first proplnts not to contain either NC or NG. The compn was Amm picrate 33.5, K picrate 15.5, Ba nitrate 39.5, woodmeal 9.5, wheat flour 1.2, K ferrocyanide 0.5, and lampblack 0.25%

Refs: 1) Daniel (1902), 686–87 (gives detailed method of prepn) 2) VanGelder & Schlatter (1927), 920–22

Robins, Benjamin (1707–1751). Brit mathematician and Engineer-General of the East India Co, considered to be the founder of the modern science of interior ballistics (Ref 3). He found that gunpowder produced "a permanent elastic fluid" of a volume 244 times that of the original powder, and was the first to notice that a cold barrel sensibly diminished the force of the powder. In 1742 he invented a ballistic pendulum, and with it he determined the velocity of a musket ball 0.25 inches in diameter with a charge of "35 hundred-weight" to be 2400ft/sec (Ref 1). His researches were recorded in his book, "New Principles of Gunnery", published in 1742

Refs: 1) VanGelder & Schlatter (1927), 19 2) Cranz, Vol 3 (1927), 40 3) J. Corner, "Theory of the Interior Ballistics of Guns", J. Wiley, NY (1950), 14, 18 & 87

Roburites. A type of permissible coal mine expl patented by Roth in Ger about 1886. The earliest type consisted of AN 90 and dinitrochlorobenzene 10%. It was claimed by the inventor that a nitrated chloro-compd gives a higher vel of deton and greater power than the corresponding nitro-hydrocarbon. The above Roburite was sensitive to friction; when ignited with a flame or spark it burned without expld. The compositions and some properties of three Ger Roburites are given in Table 1 (Ref 5)

Table 1
German Roburites

Components and Properties	Designation		
	I	II	III
Ammonium nitrate, %	87.5	71.5	55.0
Potassium nitrate, %	—	5.0	9.5
Potassium permanganate, %	0.5	0.5	0.5
Ammonium sulfate, %	5.0	—	—
m-Dinitrobenzene, %	7.0	—	—
TNT, %	—	12.0	12.0
Flour, %	—	6.0	6.0
Sodium chloride, %	—	5.0	7.0
Ammonium chloride, %	—	—	5.0
Magnesite, %	—	—	5.0
Trauzl test, cc	—	325	257

Roburites were also manufd in Engl by the Roburite Explosives Co, Ltd, who had the following formulation on the old permitted list: AN 88, dinitrobenzene 11 and chlor-naphthalene 1%. The following compn passed the Rotherham test and was on the permitted list: AN 61, TNT 16 and Na chloride 23%. Its limit charge was 18 oz, and its power (by swing of BalPend) was 2.86 inches (Ref 4)

Refs: 1) Daniel (1902), 687 2) Marshall 1 (1917), 391 3) Colver (1918), 141 4) Marshall, Dict (1920), 82-83 5) PATR 2510 (1958), Ger 160

Roca's Explosives. See under "Lithoclastites" in Vol 7, L45-L

Roca's Fuse. Safety fuse, patented in 1887 in Fr, prepd by impregnating vegetable fibers with solns of nitrates, chlorates, etc, and then drying them

Ref: Daniel (1902), 691

Rock Breakage Using Explosives. See under "Explosive Performance, Comparison of Two Methods for Its Evaluation" in Vol 6, E424-R to E429-R

Rocket. An unmanned self-propelled vehicle, with or without a warhead, designed to travel

above the surface of the earth and whose trajectory or course, while in flight, cannot be controlled. Excludes guided missile and other vehicles whose trajectory or course, while in flight, can be controlled remotely, or by homing systems, or by inertial and/or programmed guidance from within

A rocket is a missile which is propelled by the reaction of a discharging jet of gas from the burning of a charge of proplnt within the rocket. A military rocket consists essentially of a head, fuze, and a motor. The head comprises the element necessary to produce the desired effect at the target, usually an expl or chemical filler. The fuze provides means of initiating the expln of the head at the time and circumstances desired. The motor comprises the elements necessary to propel the rocket, including the proplnt charge, nozzle or nozzles, and means of igniting the proplnt. Stabilization is accomplished either by fins attached to the motor (fin type) or, in the case of multiple nozzle rockets, by so locating the nozzle that the rocket is rotated in flight (spin type)

In order that a rocket may be launched on a definite trajectory, a device called a launcher is required. Aside from providing means for initiating ignition of the rocket proplnt, the launcher is required only to aim the rocket. Consequently, rocket launchers may be so light and portable that they are wheel-mounted or motorized, aircraft-mounted, or, in the case of the bazooka, designed to be carried about by a man. They utilize rails, posts, tubes, or other devices to both carry and guide the rocket. Thus, rockets can be fired from aircraft and from ground areas inaccessible to conventional artillery

The employment of rocketry is more economical than that of artillery against light, and in some instances, heavy targets at relatively short ranges. A further advantage of the use of rockets lies in the fact that the forces of setback are relatively small but spread over a comparatively long period of acceleration, thus permitting the use of light-case projectiles of higher capacity and less expensive construction than artillery shell of similar caliber, and the use of fuzes of less rugged construction. A rocket is relatively inexpensive, easily launched, and economical as to use of personnel

A disadvantage of rockets, as compared with

conventional artillery rounds, is that operating personnel and flammable material must be protected from the rearward blast of hot gas, fragments of proplnt, wiring, and nozzle closures

Rockets are classified according to purpose as service, practice, drill or subcaliber. Service rockets are used for effect in combat; practice rockets are used for training and target practice; drill rockets are used for training and handling; subcaliber rockets are smaller rockets designed for practice purposes and for reasons of economy, and are fired from standard launchers with the aid of a subcaliber launcher inserted in the bore

Rockets are classified according to the filler as high explosive, chemical, and inert. High explosive rockets contain a filler of high explosive for blast, fragmentation, mining, or demolition effect. The high explosive antitank (HEAT) rocket, which contains a filler consisting of a shaped charge of Composition B or other high explosive, is used for penetration of armored targets

Chemical rockets contain a chemical agent and a burster or an igniter to disperse or ignite the agent at the target. The chemical agent may be a gas for producing a toxic or harassing effect, a smoke producer for screening or signaling, an incendiary, or a combination of these

The head of rockets which are intended for target practice are completely inert and fuzed with inert (dummy) fuzes; the motor contains the same propelling charge and igniter as the service rocket. Drill rockets, intended for training in service of the piece, are completely inert — both head and motor

Refs: 1) Anon, "Rockets", **TM9-1950** (1958)
2) Anon, *OrdTechTerm* (1962), 259 3) R.T. Holzmann, "Chemical Rockets and Flame and Explosives Technology", Marcel Dekker, NY (1969) 4) F.W.A. Hobart, Ed, "Jane's Infantry Weapons—1975", Franklin Watts, NY (1974), 807—08 (Rocket Launcher, 3.5-inch M20), 808—10 (66mm HEAT Rocket, M72, M72A & M72A2), 811 (M71A1 & M71A2 Training Device)

Rocket-Assisted Projectiles (RAP). In common with many European countries, the USA is devoting much effort to the development of rocket-assisted projectiles for tube artillery

In general, these developments relate to unguided projectiles, although some attention has been given to laser guidance systems for such rounds. A difficulty in developing the rocket-assisted rounds has been that of achieving sufficient accuracy, and a laser guidance technique would obviously assist in overcoming this. On the other hand, the greatly increased cost of the guided over the unguided round makes it desirable to explore the possibilities of unguided rounds thoroughly before abandoning them in favor of guided missiles

A further difficulty is the loss of payload resulting from the incorporation of a rocket motor in the projectile. In parallel with the development of the RAP rounds, therefore, there is also a program aimed at increasing the effectiveness of the reduced payload by the use of new materials and processes in the construction of the warheads

The rocket motors in the projectiles must be designed to withstand very large stresses. Mean acceleration in guns currently in service are typically about 5000g for a 105mm howitzer and about 20000g for a high-velocity tank gun, with 30000 to 40000g in sight for the next generation of the latter. RAP rounds for field artillery may thus have to withstand chamber pressures in the order of 3000kg/cm³, acceleration in the order of 18000g and rotation rates up to 17000rev/min

Two US RAP rounds, the 105mm M548 and the 155mm M549 are currently at the operational stage; following them is the 203mm projectile and there may be others. Practical development and operational considerations suggest that such rounds should be in the range of calibers extending from 40mm to 203mm

RAP projects are controlled by, and much of the work is carried out at ARRADCOM, Dover, NJ

Ref: R.T. Pretty, Ed, "Jane's Weapon Systems—1977", Franklin Watts, NY (1976), 399

Rocket Fuels and Propellants. See under "Liquid Propellants" in Vol 6, L34-R to L44-R, and "Propellants, Solid" in Vol 8, P402-L ff

Rocket Launchers. See under "Rockets" in this

Vol, and under "Cannon, Rocket Launcher or Rocket Projector" in Vol 2, C28-R

Rockeye. A US Navy general-purpose anti-armor cluster bomb designed for use against heavy tanks, trucks, and flak sites. It weighs 500 lbs and has a mechanical time fuze which dispenses bomblets at a selected time, dispensing them over a wide area

Refs: 1) J. Quick, "Dictionary of Weapons and Military Terms", McGraw-Hill, NY (1973), 376
2) R.T. Pretty, Ed, "Jane's Weapon Systems—1977", 8th Ed, Franklin Watts, NY (1976), 479

Rodman, Thomas Jefferson (1815–1871). An American who was graduated from West Point (1841) and was appointed to serve in various Arsenals where his expts in the manuf of guns soon brought him into prominence. His method of casting guns on a hollow core, the metal being cooled by a stream of w, was adopted in 1847

Rodman published "Properties of Metals for Cannon and Qualities of Cannon Powder" in Boston in 1861. In his expts with the 15-inch gun that bears his name he developed the "principle of special powders", ie, that there is a certain definite relation between the size, form and d of a powder that would give the best powder for a given gun; in other words, a powder that would give the highest velocity for a given pressure. In carrying out this idea, he first developed the "Mammoth" powder consisting of large grains compressed to high d "to render it impermeable to gases under the pressure in the gun", which was adopted for the 15-inch gun in 1861, and later, the so-called cake cartridge. These cake cartridges were perforated discs of compressed gunpowder of a diameter equal to the caliber of the gun, and from 1 to 2 inches thick. Rodman showed mathematically that at the beginning such discs presented the minimum free surface to combustion, but as the powder burned, there was a constant enlargement of the perforations, whereby the surface exposed to combustion was constantly increased as the volume of the chamber increased due to the travel of the projectile in the bore, in consequence of which the pressure developed more gradually and was more

uniformly distributed along the bore than the granulated powders hitherto employed

Sarrau (qv) later showed that this is true for BlkPdr only as long as the pressure in the gun is below a certain critical point above which the powder does not continue to burn progressively, but is ignited thruout its mass, no matter what its original d

Rodman's work is important, nevertheless, because the prismatic form powder grains of which he later built up his charges, owing to difficulties in the manuf of the cake cartridges, was adopted by all the leading nations in the world, and because his reasoning was later successfully applied to brown prismatic and to proplnt powder which is still being used in the form of perforated cylinders

The Civil War interfered with further work by Rodman, and after the war he was ordered to a post where it was impossible for him to continue his expts. However, a Russian military commission which visited the US during the Civil War was so impressed by Rodman's accomplishments that, on their recommendations, the manuf of Rodman's powder was undertaken in Russia on an extensive scale and from there it soon spread to other countries

Rodman was brevetted Brigadier-General in 1865 and promoted to the permanent rank of Lieutenant-Colonel four years before his death in 1871

Refs: 1) Van Gelder & Schlatter (1927), 23–24
2) Hayes (1938), 7 3) Pérez Ara (1945), 143 & 173 4) Anon, "Civil War Ordnance", AmOrdnAssocnHndbk (1962) 5) F.B. Pollard, "Aerospace Ordnance Handbook", Prentice-Hall, Englewood Cliffs (1966), 8–9

Rodman Guns. Muzzle-loading cast-iron smooth-bore guns of several large calibers used in the US service during and after the Civil War. The 20-inch version (of which only two were cast) weighed about 117000 lbs and fired a cast-iron shot weighing about 0.5 ton

Ref: J. Quick, "Dictionary of Weapons and Military Terms", McGraw-Hill, NY (1973), 376

Roger Powder. Blasting expl patented in Engl in 1870, contg 45% K chlorate plus materials

such as bark of cascarilla, rubber in soln, etc
Note: See also under "Chlorate Explosives" in Vol 2, C206-L

Ref: Daniel (1902), 691

Rohtri. Ger and Swiss designation for crude TNT (mp 76–78°)

Ref: PATR 2510 (1958), Ger 169-R

Roland. A surface-to-air missile for protection against low-level air attack. Built by Euromissile, Paris, Fr, this missile has a length of 2.40m, a wt of 63kg, a cruising speed of approx Mach 1.6, and a range of 500 to 6500m

Ref: R.T. Pretty, Ed, "Jane's Weapon Systems, 8th Ed—1977", Franklin Watts, NY (1976), 72–73 (Roland I and II), 103 (Marine Roland II Shipborne), & 856 (Roland IIS)

Romite. Blasting expl invented by Sjöberg about 1886 contg AN 48.8, K chlorate 38.3, naphthalene or paraffin 12.3, and moisture 0.6%. It was fairly insensitive to friction or shock, but was very unstable (Ref 1). Ref 2 states that it was used by Italy in WWII as a bursting charge in land mines

Refs: 1) Daniel (1902), 691 2) Anon, "Handbook of Foreign Explosives", FSTC 381-5042, US Army Foreign Science & Technology Center (1965), 346

Romocki's Powder. Two propmts with this name are described in the ref: 1) A progressive burning powder patented in Ger in 1889, prepd by treating compressed NC grains with alkalies. As a result, the layers closest to the surface of the grains are slower burning than those near the core; 2) A smokeless powder, patented in Ger in 1896, prepd by simultaneous pptn of NC and an aromatic nitrocompd from soln. For example, a mixt of 3p of NC and 1p of DNB were dissolved in ethyl acetate, and then pptd by adding a stream of w. The resulting ppt was collected, w-washed to remove the bulk of the solvent, shaped into grains and dried

Ref: Daniel (1902), 692

Romperit 1 (Romperite 1). A Ger WWII mining expl contg AN 86, NG with Nitroglycol 10, and Al and other ingredients 4%

Refs: 1) F. Weichelt, "Handbuch der Gewerblichen Sprengtechnik", C. Marhold, Halle/Saale (1953), 37 2) PATR2510 (1958), Ger 169 3) Anon, "Handbook of Foreign Explosives", FSTC 381-5042, US Army Foreign Science & Technology Center (1965), 291

Rompe-roca. A Cuban expl similar in compn to Rack-a-rock (qv)

Ref: Pérez Ara (1945), 233

Ronsalite. A safety mining expl patented by Pieper in 1894 in Engl. It was prepd by mixing AN 91 and mononitronaphthalene 9% in the presence of a vol solvent such as alc

Ref: Daniel (1902), 631 & 692

Roos' Explosives. Blasting expls, patented in Engl and Belg in 1899, consisted of oxidizers such as K or Na nitrates, and nitrated aromatics such as benz, toluene or naphthalene

Ref: Daniel (1902), 692

Roseburg, Oregon Explosion. A truck contg 2 tons of Dynamite and 4.5 tons of a blasting agent, trade-named "Car-Prill" (a mixt of prilled AN, ground nut shells and Diesel oil), expld with great violence and devastated the downtown section of Roseburg, Oregon on August 7, 1959. The expln, which was probably initiated by the intense heat from a nearby fire, killed 13 persons and injured more than 125 others. Property damage exceeded 9 million dollars with most of the loss sustained in areas adjacent to and including the principal business district of the city. A crater 52 ft in diameter and 20 ft deep gave mute evidence to the force of the blast. Most of the buildings in the immediate 12 blocks were completely destroyed. Hundreds of other buildings in the community suffered extensive damage over a 50-block area, and glass breakage was reported as far as 9 miles from the expln. Tremors were reported as far away as 17 miles

This hazardous cargo was being transported

by an expls manufacturer from his plant in Tenino, Washington, and was to be delivered to customers in the vicinity of Roseburg. The truck and its load of 6.5 tons of expl products had been parked en route, for the night, on a city street, just a few feet from a building-materials warehouse, which subsequently caught fire. The fire department was fighting the warehouse building fire when, in a matter of *less than 10 minutes*, the disastrous expln occurred

It is interesting to note that an incident which, in some respects, parallels the Roseburg fire and expln occurred in the isolated property of a coal company in Unionville, Ohio. On April 3, 1959, a truck transporting a cargo consisting of 4 tons of blasting agent (AN-fuel oil mixt), 150 lbs of 60% high-velocity gelatin Dynamite and about 2000 ft of detonating fuse, accidentally caught fire due to the tarpaulin contacting the hot exhaust pipe of the motor. The operator and all persons in the area promptly withdrew to a safe location. The truck and its contents burned in an open field for almost *2 hours*, when it expld with great violence. No one was injured, but the expln completely destroyed the truck and made a large crater, 40 ft in diameter and 20 ft deep

Ref: Anon, "The Roseburg, Oregon, Fire, Explosion and Conflagration", Natl Board of Fire Underwriters, NY (1959)

Rosenthal's Explosive. A mine safety expl, patented in Engl in 1898, contg AN 80, TNT 17, and Mn dioxide 3%. To this could be added 2% rosin

Ref: Daniel (1902), 693

Roseocobaltiammine Chlorate. See in Vol 1, A279 in Table C as entry "Co 14, Aquapentaminecobalt (III) Chlorate Monohydrate"

Roseocobaltiammine Perchlorate. See in Vol 1, A279 in Table C as entry "Co 15, Aquapentamine cobalt (III) Perchlorate Monohydrate"

Roseocompounds. A series of red cobalt amines, many of which are expl, of the type

$[\text{Co}(\text{NH}_3)_5]^{+2 \text{ or } +3}$. See in Vol 1, under "Ammine or Ammoniate and Coordination", A276-L to A286-R

Refs: 1) Hackh's (1944), 743 2) CondChem-Dict (1971), 216

Rosette Grain. See under "Cannon Propellant or Cannon Powder" in Vol 2, C30-R to C31-L

Rosin. See under "Colophony or Rosin", "Colophony, Nitrated" and "Colophony-Starch Nitrated Mixture" in Vol 3, C403R to C404-R

Ross and Cairney Explosive. Mining expl patented in Engl and Fr in 1899–1900. Prepd by cold mixing K chlorate (75p), charcoal (6p), Mn dioxide (6p) and paraffin wax (9p), then heating and adding molten vaseline (4p) and thoroughly blending the ingredients

Note: See also under "Chlorate Explosives" in Vol 2, C206-L

Ref: Daniel (1902), 693

Rosslin Giant Powder. A BlkPdr contg some K chlorate as partial replacement for K nitrate
Ref: Marshall 1 (1917), 385

Rosslyn's Blastite. See under "Blastite" in Vol 2, B214-R

Rosslyn Powders. Several smokeless powders patented in Engl in 1894–1895. One was prepd by treating nitrated tissue paper with K or Ba nitrate, starch and vaseline, previously dissolved in some volatile material such as benz. The resulting sheet was cut into strips of desired size and dried

Another powder was prepd by treating NC with NG and AN

Ref: Daniel (1902), 694

Rotary Drums. See in Vol 5, D1556-L to D1560-R under, "Drums, Rotary (Rotating) for Blending (Mixing) of Explosives and their

Components", "Drums, Rotary (Rotating) for Drying", "Drums, Rotary (Rotating) for Filtering", "Drums, Rotary (Rotating) for Flaking", and "Drums, Rotary (Rotating) for Testing Packaging of Ammunition"

Rotating Band. A cylindrical ring of comparatively soft metal, or similar substance. It may also be of steel pressed into a knurled or roughened grooves near the base of a projectile (or attached to the base of a projectile, as in the 4.2-inch mortar). The rotating band affords a closure for the projectile in the forcing cone of the weapon in separate-loading projectiles and centers the rear end of the projectile in the bore of the weapon. In fixed ammunition, the rotating band may not seat in the forcing cone until the instant of initial movement upon firing. As the projectile moves forward, the rotating band is engraved by the lands of the bore. Metal displaced during the engraving process flows into annular relief grooves (cannelures) cut in the rotating band. In the case of 4.2-inch mortar projectiles, the rotating band is bell shaped; it is expanded into the grooves of the mortar rifling by pressure of the propellant gases on a pressure plate. Since the rifling of the weapon is helical, engagement with the band imparts rotation to the moving projectile. The rotating band also provides obturation. It prevents escape of the propellant gases forward of the projectile by completely filling the grooves of the rifling

In the case of recoilless rifle projectiles, the rotating band is *preengraved*, with the band fitted to the projectile and containing grooves to fit the rifling of the weapon. The grooves are formed as part of the manufacture of the projectile

A *welded overlay* rotating band is formed on a projectile by depositing molten metal by welding techniques followed by machining to the required contour. This avoids weakening the projectile wall as would occur in machining the band seat deep enough to maintain a swaged band, and also reduces the possibility of band loss

Note: See also under "Rifling" in this Vol

Refs: 1) Anon, *OrdnTechTerm* (1962), 35

2) Anon, *EngrgDesHndbk*, "Ammunition Series, Section 1, Artillery Ammunition-General",

AMCP 706-244 (1963) 3) Anon, "Ammuni-

tion, General", **TM9-1300-200** (1969), 4-3 to 4-4

Rotating Drum Camera. See under "Cameras, High-Speed Photographic" in Vol 2, C14-L, and "Chronographs and Other Devices Used for Measuring Detonation Velocities of Explosives" in Vol 3, C311-L

Roth, W.A. Patented in 1886 in Fr the use of PA (up to 60%) in mixts with AN and drying oils. The resulting plastic mass was loaded into plastic cartridges, and waterproofed by means of a soln of solid hydrocarbons in turpentine. In the same year, he also patented the prepn of expls by treating tar either 1) successively with nitric acid and chlorine, or 2) a mixt of nitric and hydrochloric acids, or 3) a mixt of nitric acid and Na chloride, or 4) Na nitrate and hydrochloric acid

Ref: Daniel (1902), 694

Rotherham Test. See under "Coal Mining Explosives, Testing for Permissibility" in Vol 3, C372-L

Rotten. Patented in Engl in 1892 the following expl mixts: **No 1:** AN 77.2, naphthalene 6.2, tar oil 6.2, and varnish 10.4%; **No 2:** K picrate 38.8, anthracene 38.8, tar oil 6.9, and varnish 15.5%

Ref: Daniel (1902), 695

Rotter Impact Test. See under "Impact, Initiation of Explosion By" in Vol 7, I37-L ff

Rouge (Red) Dynamite. Contained 66–68% NG absorbed on a mineral called tripoli or tripolite (essentially ferric oxide)

Ref: Daniel (1902), 695

RPC/12 (Röhrenpulver für Canonen, 1912). One of the earliest solventless proplnts, used during WWI by the Ger Army and Navy. It was prepd

by incorporating 70p of NC (N=11.7%) with 25p of NG and 5p of centralite, and was suitable for use in large caliber guns

Ref: P. Tavernier, MP 32, 253 (1950)

R-Salt (R-Salz). See under "Cyclotrimethylene-trinitrosamine; Hexahydro-1,3,5-trinitroso-s-triazine; 1,3,5-Trinitroso-1,3,5-triazocyclohexane and R-Salt" in Vol 3, C630-R to C633-L

R.S.P. Gel (Brit). An antipersonnel incendiary mixt consisting of ordinary gasoline 76.1, crepe rubber 4.1, white P 15.0, CS₂ 2.8 and sawdust 2.0%. It was prepd by adding a nearly satd soln of white P in CS₂ to a rubber-gasoline soln. The P was pptd in finely divided condition and sawdust was added to prevent the P from settling out

Ref: C.M. Cawley et al, JInstPetroleum 34, 90-108 (1948) & CA 42, 3961 (1948)

Rubber Bonded Explosives. See under "PBX" in Vol 8, P60-L to P77-L

Rubidium and Derivatives

Rubidium. Rb; at wt 85.4678; at no 37; a soft, silvery-white metal, the second most electropositive and alkaline element; mp 38.89°; bp 688°; d 1.5324g/cc (solid at 20°), 1.475g/cc (liq at 38.5°); valence 1, 2, 3, 4 (Ref 1). Sol in liq ammonia, some aliphatic amines, tetrahydrofuran, ethylene glycol, dimethyl ether, methyl polyethers and w. The reaction of Rb with w is so violent that the released H₂ is spontaneously ignited. Rb is found in minerals such as pollucite, carnallite, leucite, zinnwaldite and lepidolite. Prepn is by redn of Rb chloride with Ca. Quant prepn of Rb is by mixing Rb chromate with Zr powd in a ratio of 1/4p by wt, compressing the mixt into rods and heating under vac in a quartz tube to 1000°. Mirror-like deposits of Rb are formed on the colder parts of the tube. The metal is pyrophoric, igniting spontaneously and violently in air, in halogens, with Hg and with w. It is kept under a dry mineral oil or in a vac or inert atm

Seventeen isotopes of Rb are known. One isotope, Rb-87 is present in natural Rb (approx 28%) and it is a beta emitter with a half-life of 5×10^{11} years. Hence, ordinary Rb is radioactive enough to expose a photographic film in 30 to 60 days

A current mil use for Rb-87 is in a portable clock and frequency std (Refs 4, 5 & 7). Also, incandescent Rb vap is used for battlefield night-vision in the form of near IR spectrum arc lamps (Ref 6)

Refs: 1) Gmelin, Syst No 24 (1937), 1, 23, 45-47 2) G. Brauer, Ed, "Handbook of Preparative Organic Chemistry", 1, 2nd Ed, Academic Press, NY (1963), 957-58 3) F.A. Cotton & G. Wilkinson, "Advanced Inorganic Chemistry . . .", Interscience, NY (1966), 418 4) M.P.R. Thomsen et al, "Improved Rubidium Vapor Cells for Frequency Standards", Rept No 7366-F, Melpar Inc, Fall Church, Contract DAAB07-67-C-0535 (1968) 5) Ibid, Rept No 7336-1 (1968) 6) C.S. Fox, "Absolute Spectral Distribution of Cesium and Rubidium Arc Lamps", Rept No NVL-6 (1969) 7) C.E. Searles & E. Simon, "Performance Characteristics of Portable Atomic Rubidium Clock and Frequency Standard", R&DTR ECOM-3339 (1970) 8) ChemRubHdb (1978), B-44

Rubidium Acetylides. See in Vol 1, A79-L under "Monorubidium Acetylide . . ." and "Dirubidium Acetylide or Rubidium Carbide"

Rubidium Azide. See in Vol 1, A596-R to A597-R

Addnl Ref: D.L. Foster et al, "The Growth and Characterization of Potassium and Rubidium Azide Single Crystals", Clemson Univ, S. Carolina, Contract DA-ARO-D-31-124-72-G120 (1975)

Rubidium Dinitrobenzofuroxane (RbDNBF). Violet crysts; d 2.208g/cc. According to Anzalone et al (Ref 2), some of the characteristics of RbDNBF are: an expln temp of 225°; a Q_C of 1931cal/g; a hygroscopicity at 30° of 0.62% wt gain at a RH of 75% and a 1.77% wt gain at a RH of 90%; an impact sensy of 3 inches on a

0.009g sample using a 2kg wt in a PicArns machine (MF=2 inches with a 0.03g sample) and, using the same sample wts, 7 inches by impacting with a 1 lb wt (MF=3 inches)

The K and Ag salts of dinitrobenzofuroxane are to be found in Vol 2, B68-L to B69-L under "Benzofuroxan and Derivatives"

Refs: 1) Beil, not found 2) A.M. Anzalone et al, "Characteristics of Explosive Substances for Application in Ammunition", PATR 2179 (1955)

Rubidium Hydride. RbH; mw 86.4757; white ndls; mp 300° (decompn); d 2.59g/cc. Sol in fused salts such as NaCl and in molten Rb. Prepn is by reacting H₂ with Rb vapor at 700° or above. It undergoes spontaneous ign with F and Cl. Reaction with w is extremely violent
Refs: 1) Gmelin, Syst No 24 (1937), 103-04 2) D.T. Hurd, "An Introduction to the Chemistry of the Hydrides", J. Wiley, NY (1952), 37-38 3) G. Brauer, Ed, "Handbook of Preparative Inorganic Chemistry", 1, 2nd Ed, Academic Press, NY (1963), 971-74 4) ChemRubHdb (1978), B-152

Rubidium Silicide. RbSi; mw 113.5; small dark crystals; bp 180-200° (high vac). Prepn is by reaction of Rb with Si (4:1) under Ar in a heated closed iron bomb. The prod req 3 to 4 days to distill under high vac. RbSi ignites explosively on contact with w or dil acids
Refs: 1) Gmelin, Syst No 24 (1937), 232 2) G. Brauer, Ed, "Handbook of Preparative Inorganic Chemistry", 1, 2nd Ed, Academic Press, NY (1963), 989-91

Run-Down Method. A statistical testing procedure developed at Frankford Arsenal, Philadelphia (Ref 1) which produces a more complete frequency and probability of reaction curve than the Bruceton, up-and-down, or staircase methods (see under "Impact, Initiation of Explosion by" in Vol 7, I36-R to I37-L). Although a larger number of tests is used than in the latter procedures, the method makes possible a better evaluation of the distribution of the population. Starting at a level expected to be between 0%

and 100% reaction levels, 20-25 tests are made at each of several levels above and below the starting level until the 0% and 100% levels are reached. The increments between the levels normally are equal to, or less than the expected standard deviation. A cumulative probability curve is then plotted from the results of the entire test which is considered to be the frequency distribution of the population (Ref 3)

Refs: 1) C.W. Churchman, "Statistical Manual, Methods of Making Experimental Inferences", Pittman Dunn Laboratories, Frankford Arsenal, Philadelphia (1951) 2) K.O. Brauer, "Handbook of Pyrotechnics", Chemical Publishing Co, NY (1974), 330-32 3) L. Avrami & R. Hutchinson, "The Sensitivity to Impact and Friction" in H.D. Fair & R.F. Walker, Eds, "Energetic Materials 2 - Technology of the Inorganic Azides", Plenum, NY (1977), 122

Ruptol B. A Belg mining expl developed and manufd in Belg consisting of AN 74.5, NG 10, DNT 4, woodflour 6.5 and NaCl 5%
Ref: Anon, "Handbook of Foreign Explosives", FSTC 381-5042, US Army Foreign Science and Technology Center (1965), 155 & 196

Russelite. A Brit permitted mining expl contg NG 40.0-42.0, NC 1.75-2.75, K nitrate 24.0-26.0, Amm oxalate 22.0-24.0, woodmeal 3.0-5.0, and chalk 0.5%
Ref: Naoúm, NG (1928), 409

Russian Coal Mining Explosives. See under "Coal Mining Explosives, Nonpermissible" in Vol 3, C441-L, and "Coal Mining Explosives, Permissible" in Vol 3, C454-L
Addnl Ref: B.D. Rossi and Z.G. Pozdnyakov, "Commercial Explosives and Initiators - A Handbook". Translation of "Promyshlennye Vzrychatyye Veshchestva i Sredstva Vzryvaniya - Spravochnik", Nedra Press, Moscow (1971), US Foreign Science and Technology Center (1973), AD 786785

RUSSIAN EXPLOSIVES AND RELATED ITEMS

A good description of the Russian explosives used during WWII is given by A.E. Pereverzev, [Trudy Leningradskago Tekhnologicheskago Instituta im Leningrad Soveta 1946, No 12, 46-48 & CA 44, 6626-27 (1950)], who reports that no essentially new high explosives were used as bursting charges in shells or other ammunition. Most improvements came from compounding previously known explosives in various mixtures, and in improved techniques for loading such charges

The principal aromatic explosives used are TNT, Picric Acid, Hexanitrodiphenylamine, Dinitrophenol, Tetryl, Dinitronaphthalene & Trinitro-m-xylene (alone or in mixts with AN and/or other substances). The principal aliphatic explosives used are PETN, RDX & Nitroguanidine. Since PETN & RDX are too sensitive to be used alone as a bursting charge, they are phlegmatized (desensitized) with wax, TNT or other coating to render them less sensitive to mechanical shock. Aluminum powder is also added to some explosive mixts or nitrocomps to give added explosive force in the bursting charge

Some captured Russian ammo, examined at PicArSn, revealed a two-layer, separate loaded type of bursting charge, novel from the Amer point of view. For example, the 76.2-mm Armor-Piercing HE Shell contained a less sensitive **Nose Charge** of "Baronal" (barium nitrate 39%, TNT 15% & Al 46%); and a more sensitive **Base Charge** of "PTX-1" (RDX 72%, TNT 16% & Tetryl 12%). The effectiveness of these combined charges is not reported

This description is based principally on PATR 2145 (1955) by B.T. Fedoroff et al, listed as Ref 33 at the end of this Section, and on the 1965 report by O.E. Sheffield, listed here as Ref 88a. The information on EXPLOSIVES is brought up to about 1970 from two recent books, that of B.D. Rossi & Z.G. Pozdnykov (1971) with Engl translation, listed here as Ref 112, and of A.G. Gorst (1972), listed here as Ref 114

Following are Russian Explosives and Related Items listed alphabetically

LIST OF
RUSSIAN EXPLOSIVES AND RELATED ITEMS

A or AT. Abbrn for Amatol

A-IX-2. An expl mixt of RDX (Gheksoghen) 73, Al (powd) 23 & wax 4%. Used for filling some projectiles

Refs: 1) Anon, "Soviet Projectiles Identification Guide", TM 30-240 (1953), 6 2) PATR 2145 (1955), Rus 1

ACVV. Abbrn for Ammiachnaya Celitra Vzryvchatyie Veshchestva, described in Gorst (1972), 140-44 (Ref 114)

Akvanity (Akvanites). Several types have been industrially tested and listed in Ref 112 (1971) giving their props but not their exact comps. Generally they are either *plastic* or *slurry* (water-filled) expls

Plastic Akvanites No 2 and No 16, have in contrast to Dynamites, a plasticizing base consisting of an aqueous soln of K nitrate, thickened to a gel-like consistency, in which AN and other constituents (such as combustibles) are also partially dissolved. Their liquid phase at normal temp is about 20-25%, of which 5-7% is water (Ref 112, pp 74-75)

Slurry-type Akvanite 3L (where L stands for l'yonshchiysya-pourable), uses as a base a thickened aq soln of AN, making up 45% of the liq phase. Other ingredients are as in Dynamites. Akvanite 3L has a liq-viscous consistency and therefore is suitable for charging descending blastholes and drillholes by the method of casting or by compression under water (Ref 112, pp 74-75)

Explosive and other props of Akvanites are given in Table 20 on p 74 of the ref, as follows:
Density, g/cc: 1.4 for No 2; 1.3 for No 16; & 1.4 for 3L

Brisance: 20mm for No 2; 18mm for No 16; 20mm for 3L, by Lead Compression Test

Efficiency (Robotosposobnost') by Trauzl Test: 380cc, 360cc & 450cc, respectively

Akvatoly (Akvatols). Several types are described in Ref 112 (1971) of which Akvatol 65/35 and *Akvatol M-15* (where M stands for Metallized) have granulated AN incorporated as the oxidizer. The role of the combustible and sensitizer is flaked TNT (Trotil or Tol in Russ), whose content in the first compn varies within 27 to 30%, while in the second, 21–22% with respect to the slurry compn. The *Akvatol M-15* contains 12.5–13.2% coarse Al powd. The thickening agent used in several grades of the Akvatols is the Na salt of carboxymethylcellulose (CMC), although it can be replaced by gel-forming agents such as guar, with binding additives such as borax or polyacrylamide powd. Technical grade CMC is used in the amt of 2.5–3.5% in Akvatol 65/35, while M-15 uses 1.0–1.5%. The water content of Akvatol slurries must not exceed 13–25% by wt

On p34 of Ref 112 is listed, without giving its compn, a gelled *Akvatol MG*, used for breaking hard rocks

Akvatols are usually prepd at plants and shipped in the form of anhydrous friable mixts, packed in paper bags for water addn at the site of use. They can also be shipped in ready-to-use water-filled slurries (Ref 112, pp 47–49)

A Table on p 49 of the ref gives explosive and other properties of which we list:

Density (Plotnost'), g/cc: 1.4–1.45 for 65/35 and 1.35–1.40 for M-15

Efficiency by Trauzl Test: 330–50cc & 465–85cc, respectively

Detonation Rate in km/sec: 4.8–5.5 & 4.8–5.8, respectively

Brisance: 25–28 & 30–34mm of compressed lead for a sample placed in a steel shell, when initiated by 10g of TNT

R.N. Solntseva et al describe in Ref 96 a chemically stable Al-contg Akvatol

Almatrity (Almatrits). A series of commercial expls developed in 1925 at the Univ of Moscow. They consisted of chlorates and perchlorates together with organic combustible materials. They were claimed to be as stable and less sensitive to friction than Cheddites (see Vol 2, C155-L to C164-R)

Following are formulations and some properties of Almatrits contg chlorates:

Kaliimatrit No 55: K chlorate 80 and combustibles (consisting of rosin 65, paraffin 30 & vaseline 5%) 12%. Density 1.15g/cc; Brisance by Compression of Lead Cylinder 10.2mm vs 18.0mm for TNT

Natriimatrit No 19: Na chlorate 90 and combustibles (consisting of paraffin 92.5, vaseline 5.0 & rosin 2.5%) 10.0%; Density 1.40g/cc; and Brisance 14.0mm

Ammonalmatrit No 98: Amm chlorate 89 and combustibles (consisting of rosin 65, paraffin 27 & vaselines 8%) 11%. Density 1.17g/cc and Brisance 16.2mm

Refs: 1) E. Spital'sky & E. Krause, SS 20, 103–07, 119–23 & 133–35 (1925) 2) PATR 2145 (1955), Rus 1 3) Ref 117a (1960), A140-L

Aluminized Explosives. Accdg to investigations conducted in Russia by Ratner and others, the incorporation of Al in expl compns has the following effects:

a) Large quantities of Al (such as 20%) raise the blast effect but do not increase the brisance. This may be due to the fact that Al oxide which forms during the reaction is volatile at the temp of expln, and volatilization takes up some of the heat

b) Smaller quantities of Al (such as 5–10%) raise the brisance of the expl if the heat of expln of the straight expl in question is around 1000cal/g

For more details, see:

Refs: 1) S.B. Ratner & Ya.B. Khariton, ZhFiz-Khim 20, 221–22 (1946) & CA 40, 5919 (1946) (Volatilization of Al oxide in the detonation wave) 2) S.B. Ratner, GornyiZhur 121 (5), 21–25 (1947) & CA 42, 4347 (1948) (Properties of Al-contg expls)

Alyumatoly (Alumatols). Combinations of AN, TNT & Al. They originated in Great Britain during WWI and later were used in France. Their compns were given in Ref 117a, A141-R & A142-L

In Ref 112, p 34, it is stated that Russian Alyumatol is a granulated, waterproof expl used in open cut work for breaking very hard rocks. Its compn is not given

Alyumit No 1 (Alumit No 1). A Russian commercial expl used during and after WWII contg AN 80, TNT 12 & Al 12%. Its properties were: Density 0.95–1.05g/cc; and Brisance by Lead Block Compression Test 16mm vs 16–17mm for TNT. It is undoubtedly one of the Alumats (Ref 88a, p 390)

Alyumotol. Accdg to Ref 112, p 39 this is a granulated melt of TNT (Tol) and Aluminum

Amatol. According to Blinov, Vol 1 (1948), p 19, two Amatols were used in Russia for military purposes: Amm nitrate/TNT 50/50 and Amm nitrate/TNT 80/20. Properties of the 80/20 Amatol: vel of detonation 5300m/sec; heat of explosion 970cal/g; temp of explosion 2890°; gas volume at NTP 896 l/kg. Being fairly insensitive, it required a large booster, or even an auxiliary booster. The following may be cited as examples of the uses of Amatol: a) **107mm HE Shell** contained 2.2 lbs of 80/20 Amatol and required a large booster; b) **120mm Mortar Shell** contained 3.5 lbs of 80/20 Amatol and used a booster of Tetryl and an auxiliary booster of PA; and c) **122mm HE Howitzer Shell** contained 7.6 lbs of 80/20 Amatol, a Tetryl booster and an auxiliary booster of about 3/4 lb of TNT

According to J.E. Capell, (private communication) among the Amatol contg weapons examined recently at PicArns were the following: d) **82mm Mortar Shell** contd 86.8/13.2 and 79/21 Amatols; e) **76.2mm Shell** contained 77.3/22.7 Amatol; and f) **107mm Mortar Shell** contd 80.7/19.3 Amatol

Ammasol. A permissible expl used prior to 1947: AN 54, TNT 12 & salt (NaCl) 34%. It is considered in Ref 112, p 6 as a modified Ammonit. Another compn contd AN 59, TNT 9 & salt 32%.

Note: This is evidently an incorrect spelling of *Ammosol* (qv)

Ammiachnaya ili Ammoniynaya Celitra. See Ammonium Nitrate abbrd as AN

Ammiachaya Celitra, Vodo-oostoychivaya Marki ZV. See under Ammonium Nitrate

Ammokasily or Ammonxyly. Non-permissible mining expls consisted of AN and TNX (Trinitroxylyene) (Ksilil, in Russ) with or w/o Al. Blinov [Ref 15, Vol 2 (1949)] gives two mixts which could also be used for military purposes: a) AN 82 & TNX 18%, and b) AN 82, TNX 12 & Al 6%. Detonation Velocity of b) was 5300 m/sec (see also Ref 117a, p 286-R)

Ammonaly (Ammonals). The original Ammonal was patented in 1900 by G. Roth and consisted of AN & Al powd, with or w/o charcoal. In later mixts the charcoal was replaced by TNT. They are defined in Ref 112, p 33 as Ammonites in which, in addn to other ingredients, Al is present

Russian WWII mixts, listed in Ref 117a, p A292 and in Blinov [Ref 15, Vol 1 (1948), p 19] were: a) AN 82, TNT 12 & Al (powd) 6%, and b) AN 80 & Al (coarser grains) 20%. Properties of b) were: Density 1.0–1.3g/cc, Brisance by Lead Compressor Test 15.5–22mm, and Trauzl Test 520cc

In Ref 112 are listed: p 5 – Ammonal used before 1930: AN 86, TNT 9 & Al 5%; pp 35 & 56–63 – *Ammonal Skal'nyi* (for breaking rocks) No 3 (no compn given; properties given); and *Ammonal Vodoustoychevyi* (water-resisting) which is a steel-gray finely pulverulent powd contg AN (water-resisting) 80.5, TNT 15 & Al powd 4.5% (p 63). Properties: Density 0.95–1.10g/cc; Brisance by Lead Compression Test 17.5mm; and Trauzl Test 420cc (pp 56 & 58 of Ref 112)

Ammonalmatrit. See under Almatrity

Ammoniynaya Selitra. See Ammiachnaya Selitra

Ammonity (Ammonits). AN expls invented in 1884 by Favier and used in many European countries, especially Russia, for industrial and military purposes. Their description is given in [Ref 117a (1960), pp A305-R to A310-L with numerous refs]. More recent description of Ammonits are given in Ref 112 (1971), pp 5–7, 33–39, 52–68 & 91–101 and by Gorst in

Ref 114, pp 142–43 (Table)

Russian Ammonits listed in Ref 117a, p A308-R and in Ref 88a, pp 391–92 include: a) AN 88 & TNT 12% (listed as *No 2*); b) AN 73, K nitrate 15 & TNT 12%; c) AN 77.6, TNT 18.4 & woodmeal 4%; d) AN 54.5 to 57.5, TNT 8.5 to 9.5, pine bark (finely ground) 2.5 to 3.5 & NaCl 31 to 33%; e) AN 59.5 to 62.5, TNX 9.5 to 10.5, pine bark 2.5 to 3.5 & NaCl 25 to 27%; f) A granulated mixt of AN 79 & TNT 21%. Listed as *Ammonit No 6* with a density 1.0–1.15g/cc; Brisance by Lead Block Compression Test 14mm vs 16–17mm for TNT; Trauzl Value 360cc vs 285cc for TNT. The same mixt, pressed to a density of 1.25–1.35g/cc, gave Brisance 20mm, Trauzl Test 360cc and Detonation Velocity 3800m/sec vs 6900 for TNT. Extensively used for blasting purposes; g) AN 81, TNT 14 & pine bark powd 5%. Listed as *Ammonit No 7* with a density 1.0–1.1g/cc; Brisance 13mm; Trauzl Test 320cc; and Deton Vel 4070 m/sec. Used for blasting; h) *Ammonit No 8*, listed by V.A. Assonov in *GornyiZhurnal* **126** (7), 25–28 (1952), is intended for use in sulfur mines. It is also listed in CA **47**, 319–20 (1953) without giving its compn. It contd Amm chloride, Na sulfate decahydrate or aq agar-agar jelly as flame extenuators. NaCl proved to be ineffective in such mines

A more extensive list of modern Russian industrial *Ammonits* is given in Ref 112. It includes, as listed by pages:

p 5 – lists the following Ammonits used betw 1932 & 1936: *No 2T* – contd AN with 12% TNT; *No 2K* – AN & 12% TNX; *No 3T* – AN & 14% TNT with TNX; *No 3TM* – AN & 13% TNT oil

p 6 – lists *Ammonit No 1* as the first safety (anti firedamp) coal mining expl. It contd 10% TNT and 10% common salt (NaCl). It had Brisance 12–14mm, Deton Vel 3.0–3.5km/sec (3000–3500m/sec), and Fugacity 360–380cc (It was measured by Trauzl Test and was referred to as “Heaving Action”; our terminology was “Power” or “Strength”)

p 6 – *Ammonit No 1* was replaced after 1947 by *Ammonit 3/1*, which contd 9% TNT and 32% salt, and also by *Ammasol* (qv)

p 7 – During and after WWII, *Safety Ammonit No 1* contd 20% salt & 10% TNT. For operations involving coal and rock-blasting

Ammonits AP-1 and *AP-2* were developed. They contd 14–15% TNT and 15–19% flame quenching agent. The difficulty with these, as well as with Ammonits Nos 6, 7, 8, etc, was caking of the AN, lack of water-resistance, and insufficient strength. Problems of water resistance and the partial caking tendency of AN expls were resolved with the development in 1956–1959 of water-resistant AN, Grade **ZhV**

p 7 – Based on the above nitrate, the waterproof *Ammonits No6-ZhV* and *No 7-ZhV* were developed. Their compns and props are given on pp 61–62 as follows: AN 79 & 81.5, respectively; TNT 21 & 16 and woodmeal 0% & 2.5%; Density 1.1 & 1.0g/cc; Brisance 14 & 13mm; and Trauzl Test Value 360 & 350cc

pp 7 & 36 – In about 1960, the rock-oriented (*skal’nyi* in Russ), *Ammonits PZhV-20*, *AP-4ZhV* and *AP-5ZhV* were developed. Their compns and props given on p 95 are: AN (waterproof) 64, 68 & 70, respectively, TNT 16, 17 & 18 and flame inhibitor 20, 15 & 12%. Densities 1.1, 1.1 & 1.1g/cc; Brisance 13, 13 & 14mm; and Trauzl Test Values 265, 285 & 300cc

p 33 of Ref 112 – Ammonits are defined as AN mixts of powdered structure in which TNT (Trotil or Tol, in Russ) or other aromatic nitro compd are used as the explosive sensitizer and the fuel. In the grain-granulated form they are known as *Zernogranulity*

p 34 – *Ammonit Skal’nyi No 1*, used in the pressed state for blasting hard rocks in open or underground works. Its props are given on p 56: Density 1.0g/cc; Brisance 18mm; & Trauzl Test Value 450cc. Its compn is not given in Ref 112

p 34 – *Ammonit V-3, Shnekovannyi* (Worm-conveyor packed) for use in flooded drillholes

p 34 – *Ammonits No 9-ZhV & No 10-ZhV*, powdery, waterproof mixts used for blasting soft or medium hardness rocks. Their compns & some props are given on p 52 of Ref 112.

Compns: AN (waterproof) 87 & 85, respectively; TNT 5 & 8 and woodmeal 8 & 7%. Brisance 10 & 11mm; and Trauzl Test Value 300 & 300cc

p 36 – *Ammonit Sernyi No 1-ZhV*, for use in sulfur mines. Its compn & props are on p 91: AN (waterproof) 52.0, TNT 11.5, woodmeal 1.5, low-freezing mixt of nitroesters 5.0, and flame inhibitor 30%. Density 1.0g/cc; Brisance 11mm; & Trauzl Test 200cc

p 36 — *Ammonit Neftyanyo No 3-ZhV*, for use in mines contg petroleum vapors. Compn & props given on p 91: AN 52.5, TNT 7.0, Ca stearate 1.5, flame inhibitor 30 & nitroesters 9% with added collodion cotton 0.3 & soda 0.2%. Density 1.2g/cc; Brisance 12mm; and Trauzl Test Value 230cc

p 36 — *Ammonit T-19*, a safety (predokhranitel'nyi) expl used in fiery mines. Its compn & props given on p 95: AN (waterproof) 61, TNT 19 & flame inhibitor 20%. Density 1.1g/cc; Brisance 14mm; & Trauzl Test 265cc

p 36 — Cartridges for *Ammonit* slurries in PVP-1-U (polyethylene) shells. Its illustration (Fig 2) and description is shown on p 108 of Ref 112. On the same page is shown in Fig 3 the Resite-salt shell for **MGPP-50** cartridges. It is described on p 110

p 36 — *Shashki* (Demolition Charges) *Skal'nago Ammonita* are compressed charges which serve as intermediate initiators for detonating nearly insensitive expls

Ammonit-Goudronit. A coal-mining expl consisting of AN & tar (goudron). It is mentioned in N.A. Shilling's book (Ref 11, p 106), **PATR 2145** (Ref 33, p Russ 3), and in Ref 88a, p 392, without revealing its compn, but giving its props as follows: Brisance by Lead Block Compression Test 13mm; Trauzl Test Value 300–40cc; Detonation Velocity 4000m/sec; Heat of Combustion at C_v 813cal/g; and Temperature of Explosion 2400°K (see also Ref 117a, p A310-L)

Ammonit Predokhranitel'nyi (Safety Ammonit). Accdg to Ref 88a, p 392, this current, commercial mining expl consists of AN 68, TNT 10, powd pine bark (or oil cake) 2 & NaCl 20%. It has a density of 1.0–1.05g/cc; Brisance by LBCT 11mm (vs 16–17mm for TNT); Trauzl Test Value 240cc (vs 285 for TNT); and Detonation Velocity 2870m/sec (vs 6900 for TNT at d 1.59g/cc)

Ammonit V-3 v Poroshke (in powder). Contd: AN (not waterproof) 82.0, TNT 16.5, asfal'tit 1.0 & paraffin 0.5%. Brisance 14mm; & Trauzl Test Value 360cc (Ref 112, p 52)

AMMONIUM NITRATE (AN) (Azotnokislyi Ammonii, Ammiachnaya or Ammoniynaya Celitra), NH_4NO_3 . A detailed description of its preparation, properties, uses and analytical procedures are given in Vol 1 of the Encyclopedia, listed here as Ref 117a, pp A311 to A379. It is used extensively as an oxidizing agent in military and industrial explosive mixts

Accdg to Rossi & Pozdnyakov (Ref 112, p 7), the Russians developed a successful water-resistant AN designated **Mark ZhV**, in 1956–1959, which became the main source of starting material for powdered-type explosives. Based on this nitrate, *Ammonity No 6-ZhV* & *No 7-ZhV* began to be manufd, along with *Ammonits PZhV-20*, *AP-4ZhV*, *AP-5ZhV* and others. Other expls using ZhV celitra were Ammonal, Igdanit and Zernogranulit

The water resisting AN, **Mark ZhV** is called *Ammiachnaya Celitra Marki ZhV* in Russia, where Zh stands for Zhelezo (Rus for iron) and V for Vodo-oostoychivaya (Rus for water-resisting). In order to diminish the hygroscopicity of AN, its aqueous soln is treated with a small quantity of iron sulfate (sernokisloye zhelezo in Rus) before evaporation of the water. The resulting grains of AN are then treated with a mixt of fatty acids & paraffin in 1:1 proportion. The so-treated AN is also called *ozhelezennaya celitra* [Gorst (1972), p 141 (Ref 114)]

Not all Rus AN explosive compns contain water-resisting AN. Many contain plain grained (granulated), prilled or crystalline AN, prepd probably similarly to the methods described in Ref 117a, p A314-R

The following Russian expl mixts were based on AN: Akvanity, Akvatoly, Almatrit (Ammon), Alymatoly, Alyumit No 1, Amatoly, Ammoksil, Ammonaly, Ammonity, Ammonit-Goudronit, Ammonit Predokhranitel'nyi, and others

Ammonium Nitrate as a Straight Explosive. Accdg to investigations conducted in Russia, the use of straight AN as an explosive was not justified. It proved to be more advantageous to use mixts of it with combustible materials, which also serve as sensitizers. For example, a mixt of AN with 10% powd pine bark gave a Trauzl Block Test Value of 300cc as compared with 225cc for straight AN. Still better results

are obt'd if the bark is replaced with TNT or other aromatic nitro compd

Refs: 1) G.A. Abinder & K.K. Andreev, Gornyi-Zhur **1939** (7), 42-43 & CA **34**, 8283 (1940)
2) A.G. Horst, *Ibid* **1939** (7), 43-45 & CA **34**, 8283 (1940)

Note: Some other investigators, such as V.A. Assonov & B.D. Rossi, GornyiZhur **1939** (7), 38-41 & CA **34**, 8283 (1940) claimed that there is some advantage in using straight AN as an explosive in open pit mining

Ammonpek. Accdg to Blinov, Vol 2 (Ref 15), it is a mixt of AN 95 with coal tar pitch (pek) 5%. It was used in mining as a substitute for Ammonit Goudronit. It was known for its low sensitivity to impact and initiation (Ref 88a, p 393 & Ref 117a, p A362-L)

Ammontol. A castable HE mixt of AN 50, TNT 38 & TNX (Ksilil, in Rus) 12%. Used for loading some projectiles (Ref 88a, p 393). Blinov (Ref 15, Vol 2, pp 64-65) calls it *Russian Mixture* (Russkaya Smes') while Gorst (Ref 40, p 99) gives the following formulation for *Russkaya Smes'*: PA (Picric Acid) 51.5 & DNN (Dinitronaphthalene) 48.5%, with no AN. *Russkaya Smes'* is not listed in the 1972 edition of Gorst (Ref 114) (see also Ref 117a, p A383-L)

Ammonxyl. See Ammoksil

Ammosol. Spelled *Ammasol* in Ref 112, p 5, is a permissible expl proposed in 1937 by C.I. Rudakovskii and listed in Ref 58, p 113. It consisted of AN 56, TNT 12 & NaCl 32%. Its Heat of Expln is 625cal/g, and temp developed on expln is 2180°

AT. Abbrn for Amatol

Azid Svintsa (Lead Azide, LA), PbN_6 . A detailed description is given in Vol 1 of the Encycl (Ref 117a, pp A545 to A587). Prepn and uses of LA in Russia during and after WWII are described by Blinov, Vol 1 (1948), p 19 (Ref 15); Gorst

(1957), p 108 (Ref 40); Rossi & Poznyakov (1971), p 180 (Ref 112); and Gorst (1972), p 100 (Ref 114)

LA has been used in detonator caps (when phlegmatized by 1-2% paraffin), either straight or in conjunction with Lead Styphnate (LSt) (Stifnat Svints or Teneres) (TNRS) (Trinitroresorcinol) placed in two distinct layers. This LA-LSt combination, known as *Azidotenerosovaya Smes'*, practically replaced MF (Mercuric Fulminate) (*Gremoochaya Rtut'*, in Rus). This because LA has the following advantages over MF: it is less sensitive to impact and friction; less readily dead-pressed; cannot be rendered insensitive to initiation by the presence of water; and possesses better stability in storage (Ref 33, p Rus 10-R and Ref 114, p 100)

Azotnaya Kislota (Nitric Acid, NA), HNO_3 . In the method used before WWII, NA was prep'd by heating Na nitrate (Chile saltpeter) with sulfuric acid, while the current method consists of oxidation of anhydrous ammonia in the presence of catalyst (Pt gauze)

A very detailed description of manuf & props, but no uses, is given in V.I. Atroshchenko & S.I. Karghin, "Tekhnologhiya Azotnoy Kisloty" (Technology of Nitric Acid), Gos-NauchTekhn-IzdatKhimLiterat, Moscow (1949)

Azotnokislyi Ammonii. See AMMONIUM NITRATE

Bel-aya Smes' (White Mixture). An older percussion compn which consisted of MF (Mercuric Fulminate) 80-85 & K chlorate 20-15% (Ref 11, p 144) and (Ref 33, p Rus 3-L)

Belyi Fosfor (White Phosphorus, WP). Was used in pyrotechnic and incendiary compns

Belity (Bellites) are commercial blasting and mining expls consisting of AN and MNB (Mononitrobenzene), which was later replaced by DNB (Dinitrobenzene). Shilling (Ref 11, pp 97-98) listed the following compns: a) AN 35 &

DNB 65%; b) AN 87 & DNB 13%; and c) AN 80, TNX (Trinitroxylyene) 12 & DNB 8%

Accdg to Ref 88a, p 394, Belity were extensively used in the Russian coal mining industry

Col M.M. Kostevich listed compn: AN 83 & DNB 17% used during WWI by the Russians for loading bombs and grenades (Ref 117b, p B33-L)

Berdanka (Berdan Rifle). Accdg to the late Col M.M. Kostevich, it was a 10.6 or 10.8mm one-shot breechloading rifle with a bolt system magazine developed in the 1870's by American General Berdan and adopted (after being rejected by the US Govt) by the Russian Imperial Govt for the regular troops. The weapon proved to be so successful that it was used for many years. Although it was replaced in the Regular Army at the beginning of 1891 by the 5-cartridge magazine rifle, called *trékhlíneynaya vintovka* (three line rifle), the "berdanka" was used by irregular troops and "opolcheniye" (Civil Home Guards) as late as WWI, and probably to this day for sporting purposes. The cavalry model of the berdanka was used for training in military schools (Kadetskiye Korpoossa – Corps of Cadets) (Ref 33, p A3-L & Ref 117b, p B101-R)

Bertolletovaya Sol' or Khlorat Potassiya (Potassium Chlorate), $KClO_3$. Described in Vol 2 of the Encycl, under Chlorates (Ref 117b, pp C190-R to C197-L). Russian chlorate expls are described by Gorst (Ref 114, p 144). Chlorates are used in Initiating Compositions, such as Gremoochiya Smes'. It was also used in HE mixts such as $KClO_3$ 80 & DNT 20% described in Gorny, Zhur 116 (12), 47–48 (1940)

Bezopasniye Vzryvchatyiye Veshchestva. Safety Explosives. They include expls safe to handle and transport. In some publications they are called "safe to use in coal mines", but for such expls (called in the USA "permissible" and in GtBritain "permitted") a special term "predokhranitel'nyiye (protected) VV exists. An older term was "grisoutnyiye VV" from the French word "grisou" which means "firedamp" (mixture of

methane with air)

Most of these expls are based on AN (Ammonium Nitrate) as an oxidizer and carbon compds as a fuel. As a "flame repressor", common salt (NaCl) has been used

BLACK POWDER or GUNPOWDER. (BlkPdr, Chörnyi Porokh ili Dymnyi (Smoke) Porokh). A detailed description of BlkPdrs is given in Vol 2 of the Encycl (Ref 117b, pp B145-R to B179-R). Russian BlkPdrs of WWII are described by Blinov, Vol 1, pp 20 & 181 and Vol 2, p 76 (Ref 15)

Two principal BlkPdrs were used during WWII for military purposes: melkozernisty (small grains, 1mm) and kroopnozernisty (large grains, 5–10mm), also known as artilleriyskii. They were used in some Igniter and Delay Compositions and as a burster (ejector) charge in some projectiles, such as Shrapnel, Incendiary, Illuminating and Leaflets for Propaganda

Following are the compns of typical Russian BlkPdrs:

	KNO_3	Sulfur	Charcoal
Military	75	10	15%
Fuse Pdr	78	12	10%
Blasting (a)	75-84	8-10	8-15%
Blasting (b)	66.6	16.7	16.7%
Tubular	60-75	13-37	4-7%
Sulfurless	80	—	20%
Sporting (a)	74-78	8-10	14-16%
Sporting (b)	80	8	12%

Accdg to E.E. Sancho, "Quimica de los Explosivos", Aguado, Madrid (1941), p 261, two compns were manufd at Okhtenskii Zavod at St. Petersburg: Type A: KNO_3 78.40, sulfur 2.01 & charcoal 19.59% and Type B: KNO_3 75.21, sulfur 4.08 & charcoal 20.71% (Ref 33, p Russ 3 & Ref 88a, p 395)

Brizantnyiye ili Drobyshchiye VV. (Brisant or Crushing Explosives). Accdg to the classification given by Gorst (Ref 114, pp 22–23), these expls belong to Group II and are also known as Vtorichnyiye VV or Secondary Explosives. They correspond to American High Explosives (HE)

To Group I belong Initsiiyoooyoushchiye (ili Pervichnyiye) VV – Initiating (or Primary)

Explosives

To Group III belong *Metatel'nyiye VV* (Launching Expls) ili *Porokha* (Propellants)

Buryi i Shokoladnyi Porokh (Brown & Chocolate Powder). General description of Brown Powders (BrnPdrs) is given under **BLACK POWDER** Modifications in Vol 2 of the Encycl (Ref 117b, p B173). Russian Brown Powder was similar in compn to Russian BlkPdr, except that the charcoal was brown because it was only partially carbonized to the extent of a carbon content of 70–75%. This was called *Buryi Porokh*. It was slower burning than BlkPdr. Still slower was the *Shokoladnyi Porokh* which contd charcoal with a 52–54% carbon content

Some Brown Pdrs were used in Delay Compositions (*Sostavy Zamednemago Deystviya*), and for Time Rings of Fuzes (*Distantсионnyiye Kol'ts a Snaryadnoy Troobki*). The compns of such BrnPdrs were: a) Brown coal 4, K nitrate 59 & sulfur 37%; velocity of burning 3mm/sec; b) Brown coal 6, K nitrate 67 & sulfur 27%; velocity of burning 3.8mm/sec; and c) Brown coal 7, K nitrate 76 & sulfur 17%; velocity of burning 3.4mm/sec (Ref 88a, p 394)

Camphorated Blasting Gelatin (*Gremoochii Studen's Kamforoy*). Blasting Gelatin made safe to handle by incorporating some camphor, as in a compn contg NG 90, Collodion Cotton 7 & camphor 3%. This was used as a filler for some bombs and trench mortar shells by the Russian Army as late as WWI

Ref: Ph. Naoum, "Nitroglycerine", Williams & Wilkins, Baltimore (1928), pp 11 & 310

Cilatvor or Silatvor. From the Russian word *cila* (*sila*), which means "force", and *tvorit*, which means "to create". Accdg to J. Daniel, "Dictionnaire des Matières Explosives", Dunod, Paris, p 716, *Silatvor* was an expl mixt based on nitrated non-resinous sawdust. It resembled *Schultze's Pulver (qv)* and was tried in 1886–1887 as a bursting charge in shells and torpedoes to replace BlkPdr. It proved not to be safe to use as a bursting charge because it detonated prematurely. It could not be used as a proplnt

because it was too quick-burning [Col M.M. Kostevich, private communication, Buenos Aires, Argentina (1955)]

Decoppering Composition (*Protivo-omednitel', Razmednitel'*). Accdg to Blinov (Ref 15, Vol 5) many Russian artillery rounds used lead wire coils placed between the proplnt charge and the projectile. Sn or alloys of Pb-Sb or Pb-Zn were also used. It was believed that on firing a round the particles of Pb or its alloy fused with a deposit of Cu (or gilding metal) from the rotating band in the gun barrel. The resulting alloy was rather brittle and could be more readily discharged on subsequent firings than deposits of straight Cu or gilding metal (Ref 33, p Rus 4-L) (See also under *Prossal'nik*)

Detonity (Detonites). Powdery w-resistant expl compns used in hard rock blasting. The following are listed in Ref 112, pp 69 & 71:

Designation	6A	10A	15A-10
Low-freezing org nitrates, %	6.0	10.0	14.7
AN (w-resistant ZhV), %	78.0	76.0	74.0
TNT, %	11.0	8.0	—
Al (powder), %	5.3	5.2	10.0
Ca stearate, %	0.7	0.7	1.0
Collodion cotton, %	—	0.1	0.3
Soda (added above 100%)	0.2	0.2	0.2
Density, g/cc	1.1	1.1	1.1
Brisance, Pb compression, mm	17	17	18
Detonation Velocity, m/sec	4000	4200	4300

Note: See also Ref 114, p 142

Dinaftalit (Dinaphthalite) **Vodo-oostoichivyi** (Water resistant). According to Gorst (Ref 114, p 142), it is an expl mixt consisting of AN 88.0, DNN (Dinitronaphthalene) 11.6, and paraffin 0.4%. Its d is 1.0 to 1.15g/cc; brisance by Pb compression test 15mm; and Trauzl Test Value 320cc. Ref 88a states that it was used as a bursting charge in shells as well as in commercial blasting

Dinitrobenzol (Dinitrobenzene, DNB). Described in Vol 2 of the Encycl, B46-L to B47-R. DNB was

prepd in Russia by the nitration of benzene and purified by treating it with alk Na sulfite at a temp of 65°. The yield of the commercial product was 87%, mp 88–89°, d 1.5g/cc, and cast d 1.45g/cc. A detailed method of prepn is given in Ref 1. As the cost of DNB in Russia was lower than that of TNT, it was used quite extensively, either straight (for cast-loading shells) or in a mixt with other substances, such as PA, AN, etc. See also under Belity and K-1 Splav
 Refs: 1) Shilling (1946), p 97 2) Blinov 2 (1949) 3) Gorst (1972), p 139

Dinitronaftalin (Dinitronaphthalene, DNN). Described in Vol 8 of the Encycl, N9-L to N12-L. Russian commercial DNN is a mixt of several isomers. As its explosive properties are very weak and it has an oxygen deficiency, DNN cannot be used alone. It can, however, be used in admixtures with other expls or oxidizers, eg, in Schneiderite (AN 88, DNN 12%), or Frantsuzskaya Smes' (PA 80, DNN 20%). A demolition charge examined at PicArns consisted of about 92 TNT and 8% DNN (Ref 3)
 Refs: 1) Shilling (1946), p 101 2) Blinov 2 (1949) 3) E.F. Reese, Private Communication 4) Gorst (1972), p 139

Donar Vzryvchatoye Veshchestvo. See under Fielder Explosive in Vol 6 of Encycl, p F20-R

Dynamites (Dinamity). Following are the principal types of Dynamites used in Russia:
 a) **Gremuchii Studen'** (Blasting Gelatin): NG 87–93 & Collodion Cotton 13–7%;
 b) **Plasticheskii Dinamit** (Plastic Dynamite): NG 62–83, collodion cotton 3–6, K or Na nitrate 27–29, and woodmeal 8–2%;
 c) **Grisutin**: NG gelatinized by Collodion Cotton 12–30 and AN 88–70% with an absorbent such as limestone, sawdust, etc, added (Ref 15, Vol 2)

According to Ref 112, p 35, the Russians also used to some extent a plastic 62% Dynamite contg AN for blasting hard rock formations

See also under Dynamite in Vol 5 of Encycl, p 1584 ff

Dynamons (Dinamony). A detailed description is given in Vol 5 of the Encycl, pp D1742-R to D1743-R

The following additional Dinamony are mentioned in Ref 112, p 61: Dinamony AM-8 and AM-10, contg respectively: AN 89 & 87.7, paraffin 8 & 10, and mineral oil 3 & 2.3%. Their densities were 1.0g/cc; Brisance 13 & 14mm; and Trauzl Test Values 400 & 420cc

Explosives (Vzryvchatyye Veshchestva) Used during WWII. A short description of such expls was given by A.E. Pereverzev, Trudy Leningrad Inst, 1946, No 12, pp 47–68 & CA 44, 6626 (1950). He classified them as follows:
 a) TNT (Trotil) was the main component, constituting 40 to 50% of the total HE used;
 b) Aromatic nitrocompds other than TNT, of which the principal were: Picric Acid, Hexanitrodiphenylamine, Tetryl, Dinitrophenol, Dinitronaphthalene, and Trinitro-m-xylene (whether alone, or in mixts with AN and other substances);
 c) Aliphatic nitrated compds of which the principal were: PETN, RDX and NGu. Inasmuch as PETN and RDX are too sensitive to be used alone for filling projectiles, they were phlegmatized with wax, TNT, etc, to render them less sensitive to mechanical action. NGu was used in Russia as both a HE and proplnt component; and
 d) Expls used as components of single and double-bse proplnts such as NC, NG, Nitroglycols, etc

Gheksoghen (Hexogen, Cyclonite, RDX). See under Cyclotrimethylenetrinitramine in Vol 3 of the Encycl, pp C611-L to C630-L, and under RDX in this Vol. It was prepd in Russia during WWII by the nitration of urotropin (hexamethylene-tetramine), a material synthesized by Butlerov in 1859

Straight RDX was used in some detonators, detonating fuzes and boosters (promezhutochnyye detonary), and RDX phlegmatized with wax was used for filling some small caliber projectiles. A more extensive use of RDX was in mixts with other expls, such as TNT (to make RDX castable), and with Al, AN, etc. In admixtures with TNT and Tetryl it was used in: RDX/TNT/Tetryl –71.9/16.4/11.7% for filling 76.2mm APHE shells. Its admixture with Al and a binder (such

as RDX 75.1, Al 20.8, binder 4.1%) was used as a bursting charge in 25mm HE shell. A similar admixture, RDX 74.5, Al 22.3, binder 3.2% was used in 85mm antiaircraft (Zenitnyi) shell, and another, RDX 73.9, Al 21.4 and binder 4.7% was used in the 45mm APHE-T shell. It is possible that the last 3 mixts were intended to have the same compn

Refs: 1) Anon, PB Rept 11544 (1945)
2) Shilling (1946), 92 3) Blinov, Vol 2 (1949)
4) F. Pristera et al, PACLR 132066 (1951)
5) C. Ribaud et al, PACLR 51-7-574 (1951)
6) J. Campisi et al, PACLR 51-7-951 (1951)

Grammonal A-8. Granulated Ammonal with an increased Al content (8%). It is classified as being among the most powerful expls intended for underground use in breaking hard rocks (Ref 112, p 83). Its props are described in detail on pp 80–81, but no compn is given. **Grammonal A-45** is listed on p 34 of Ref 12 as a granular, w-resistant AN expl for open pit blasting of hard rock. Its compn is not given. It is also described in Ref 99

Granulity (Granulites). Granulated mining expls. The compns and props of the following formulations are given in Ref 112, pp 85–86:

Components, Granulites:	AC-8	AC-4	C-2	M
AN, granulated, %	89.0	91.8	92.8	94.5
Al, powdered, %	8.0	4.0	—	—
Woodmeal, %	—	—	3.0	—
Mineral oil, %	3.0	4.2	4.2	5.5
Density, g/cc	not given			
Brisance,				
by Pb compression, mm	24	22	15	18
Detonation Velocity, m/sec	3000	2600	2400	2500
Trauzl Test Value, cc	410	390	320	320

Granulites are used for blasting rocks of various degrees of hardness

Granulotol. Listed in Ref 112, p 34 as a granular, w-resistant AN expl used for hard rock blasting in open pit mining. No compn is given. On p 139 of the ref, the name **Granilotol** is used for granulated TNT

Gremoochaya Rtoof' (Fulminate of Mercury, Mercuric Fulminate, MF). Prepd in the same manner as described in Vol 5 of the Encycl, pp F217-L to F220-R. It was used in initiating compns, usually contg K chlorate and Sb sulfide, but has been gradually replaced by Pb Azide and Pb Styphnate

Refs: 1) Blinov, Vol 1 (1948), p 16 2) Gorst (1972), p 90

Gremochii Studen' (Blasting Gelatin). Same as Blasting Gelatin, described in Vol 2 of the Encycl, pp B211-R to B212-L

Gromoboy (Thunderer). A powerful expl consisting of AN 72.5 and Amm Picrate 27.5%, proposed in 1886 by I.M. Chell'tsov for loading shells and naval mines. See Vol 6 of the Encycl, p G145-L

Igdanit. A blasting expl contg AN 95–97 and Diesel oil 5–3%, combined *in situ* just before use. It was reported that Igdanit has better characteristics than Ammonit (qv)

In Ref 112 the compn of Igdanit is given on p 85 as AN (granulated) 94.5–94.0 and Diesel fuel 5.5–6.0%. Properties, given on p 86, include: Brisance by Pb Compression, 15–20mm; Detonation Velocity, 2200 to 2700m/sec; and Trauzl Test Value, 320–330cc. On p 35 of Ref 112, it is stated that Igdanit is used for blasting dry, medium hardness rock formations
Ref: W.S. Khablov, PromStroit (Industrial Construction) 39 (4), 55–56 (1961) & CA 55, 20433 (1961); Ibid, Explosivst 1964, p 47

K-1 or K-2 Splav. See in Vol 7 of the Encycl, p K1-L

Kapsiul' Detonary, Kapsuil' Vosplamenitel'. See in Vol 7 of the Encycl, p K2-L

Kcilil (Ksilil). See in Vol 7 of the Encycl, p K19-L

Khlopchatoboomazhnyi Porokh. Same as Guncotton, described in Vol 2 of the Encycl, pp C106-R to C108-R, and in this Section under Nitrocellulose

Kollokcilin, Kolloksilin or Kollodion. A term applied to NC with a 11–12% N content. Same as Collodion Cotton, described in Vol 2 of the Encycl, pp C100-L to C105-L, and in this Section under Nitrocellulose

Mansit. An expl mixt consisting of AN 72, Amm Picrate 23 and petroleum asphalt 5%
Ref: Blinov, Vol 2 (1948)

Mazut or Masutt. See in Vol 8 of the Encycl, p M47-R

Melinit ili Pikrinovaya Kislota (Picric Acid, PA, 2,4,6-Trinitrophenol). See under Picric Acid in Vol 8 of the Encycl for a detailed description of prepn and props

The manuf of PA in Russia started about 1896 to replace compressed Guncotton used at that time as a bursting charge. The replacement was not yet completed when the manuf of TNT commenced (about 1907). When WWI began, the Russians had three types of bursting charges: compressed NC, PA and TNT. Straight PA was used during WWII to a limited extent for loading some shells, bombs, older types of boosters, and as a base charge in some detonators

Note: Although the Russians used some PA-loaded shells during the Russo-Japanese War of 1904–1905, they were not as effective as the Japanese shells. This was due to the fact that the Japanese used cast PA prepd by a special method developed by Capt Shimose (called Shimozation), which gave bursting charges of higher density than the PA-loaded Russian shells
Refs: 1) Shilling (1946), pp 85 & 90
2) Blinov, Vol 1 (1948), pp 17 & 18

Miporit. A permissible expl (Predokhranitel'noye VV) for use in very gaseous coal mines (Ref

112, p 36). Its compn is given on p 95: AN (waterproofed) 65, TNT 15, flame inhibitor 18, and Mipora (foamed urea-formaldehyde resin) 2%. Its props, listed on pp 95, 96 and 100, include: Density of cartridges 0.85–1.0, Brisance 13mm, Detonation Velocity 3500m/sec, and Trauzl Test Value 265cc

Nitrocellulose (Nitrokletchatka, Nitrotselulosa, NC). NC manufd in Russia may be divided into **Piroksilins** and **Kolloksilins**

Piroksilins, which are NC's with a N content of 12% or more, may be divided into Piroksilin No 1, NC with a N content of 13 to 13.5%, practically insol in eth-alc, and Piroksilin No 2, NC with a N content of 12.05 to 12.4%, and sol in eth-alc to the extent of 45%. Piroksilins have been used for the prepn of smokeless proplnts (bez dymnyye porokha), but formerly they were also used in compressed form as HE's for loading shells, torpedoes, etc, as well as in Dynamites

Kolloksilins or Colloxylines are NC's with a N content of 11.5 to 12%, completely sol in eth-alc and methanol. Used in the prepn of Dynamites, celluloid lacquers, etc

See also under Cellulose Nitrates or Nitrocelluloses in Vol 2 of the Encycl, p C100-L ff
Refs: 1) Shilling (1946), p 163 2) Blinov, Vol 2 (1949), p 17 3) Gorst (1972), p 146 ff

Nitroglitserin (Nitroglycerol, NG). Its prepn, props and uses are described in Vol 6 of the Encycl, p G98-R ff

Okto ghen (Octogen or HMX). Designation for Cyclotetramethylenetetranitramine, described in Vol 3 of the Encycl, pp C605-R to C610-R. Its beta form is described on pp C606-R to C609-R

Ref 88a, p 402, states that in addition to its normal use as a component of powerful HE's, Octogen and other high energy expls plus an expl plasticizer are incorporated, in place of NG in proplnt casting solvents and other rocket fuels. Octogen has also been added to upgrade the performance of double-base proplnts [see Gorst (1972), p 138, listed as Ref 114]

Pikrat Ammoniya, ili Pikrinovokislyi Ammonii (Ammonium Picrate, Explosive D, Dunnite). See in Vol 8 of the Encycl, pp P276-R to P279-L. It was used in Mansit (qv)

Pikrinovaya Kislota (Picric Acid). See under Picric Acid in Vol 8 of the Encycl, and Melinit above

Plamyagacitel' (Flame Extinguisher). The Russians used essentially the same materials described in Vol 6 of the Encycl under Flash-Reducing (or Antiflash) Agents (pp F96-L to F98-R), and Flash Reduction in German Projectiles and Propellants (pp F99-L to F100-L)

Pobedit VP-4. A permissible expl for use in methane contg mines: AN (w-resistant) 65.5, a mixt of low-freezing organic nitrates such as NG and Nitroglycol 9.0, TNT 12.0, flame extinguisher 12.0, and woodmeal 1.5%; with added Collodion Cotton 0.13, Ca stearate 0.1, and soda 0.1%. Its d is 1.15g/cc, Brisance by Pb compression 15mm, Detonation Velocity 4000m/sec, and Trauzl Test Value (Rabotosposobnost') 330cc. Several other Pobedites are known (Ref 112, pp 36, 91 & 93)

Promezhutochnyi Detonator (Intermediate Detonator). Russian term for a booster. As in the USA, Tetryl was chiefly used before and during WWII, although some PA was also used. Some straight RDX and PETN boosters came into use during WWII (M.M. Kostevich, Private Communication, Buenos Aires, Argentina, 1955)

Prossal'nik (Lubricating Gasket, Bore Lubricator). In order to increase the life of a gun barrel during firing, the Russians designed a special lubricating device called "prossal'nik" which they occasionally used. It was claimed that propnt gases caused the lubricator to disintegrate and the lubricant to be splattered inside the bore, thus depositing a protective insulating coating on the bore surface

Bore lubricators were tried in separate loaded

rounds for 107mm and 122mm guns with a full charge. The device consisted of a cardboard obturator, cardboard covers (between which was placed a thick ring consisting of a mixt of red Pb, ceresin, and vaseline) and a gasket. Bore lubricators were usually mounted on the boat tail (or base) of the projectile during loading (Refs 1 & 3)

It was claimed by the Russians that the use of "prossal'nik" increased the life of the gun (Ref 1), but according to US sources (Ref 2), the use of bore lubrication decreased the muzzle velocity. When oil was used as a lubricant, the muzzle velocity of the first round was practically the same as in the gun previously cleaned and dried, but velocities of the 2nd, 3rd, etc rounds were appreciably lower. After firing a number of rounds (number not stated) the muzzle velocity started to climb back to that obtained when firing was conducted in a gun not previously lubricated (Ref 2)

According to Capell (Ref 3) other countries evaluated bore lubricants and concluded that they had no great value

Refs: 1) Blinov, Vol 4 (1947), p 67; Vol 5 (1949), p 163 2) Anon, Combat Forces Journal (USA), Vol 4, No 8, p 40 (1954) 3) J.E. Capell, PATR 2033 (1954) & private communication

Ruskii Koktel (Russian Cocktail). An incendiary liq used against tanks during WWII, contg about 80p of K chlorate and 20p of Nitrobenzene, Nitrotoluene or Nitroxylyene. The mixt ignited when touched with a drop of concd sulfuric acid. Stettbacher calcd the heat generated as 1182kcal/kg accdg to the reaction:

$$25\text{KClO}_3 + 6\text{C}_6\text{H}_5\text{NO}_2 \rightarrow 36\text{CO}_2 + 15\text{H}_2\text{O} + 25\text{KCl} + 6\text{N}$$
 Ref: A. Stettbacher, Protar 10, 160 (1944)

Ruskii Splav (Russian alloy or fusion). An expl mixt used for charging mines, bombs and shells: PA 51.5 and DNN 48.5% (Ref 11, p 90)

Selectite No 1 (Celegtit No 1). A granulated, friable, w-resistant AN expl, sensitized with a 10% low mp mixt of nitro esters. It is classified as a selectively detonating safety expl, and is

used in dangerous coal mines and for special applications. Its props are given as: Density 1.1g/cc; Brisance 6 to 10mm; Detonation Velocity ca 1900m/sec; and Trauzl Test Value ca 230cc (Ref 112, pp 34, 102, 104 & 107)

Shaped Charge (Konoolytivnyi ili Broneprozhigayoushchii Zaryad). A detailed description of the Shaped Charge is given in Vol 4 of the Encycl under Munroe-Neumann Effect, pp D442-L to D454-L

Accdg to Ref 112, p 112, several types of Russian commercial shaped charges are produced for use in open-pit mining. They differ in size, weight, and sometimes in the type of expl used. Charges are usually prepd from cast or pressed TNT, and less often from Tetryl, Pentolite or phlegmatized RDX. The external surfaces of the charges are coated with a protective of varnish or paraffin to make them waterproof and to increase safety in handling. They can also be used for under-water blasting

An illustration of one such charge, given as Fig 4 on p 113 of Ref 112 is shown below:

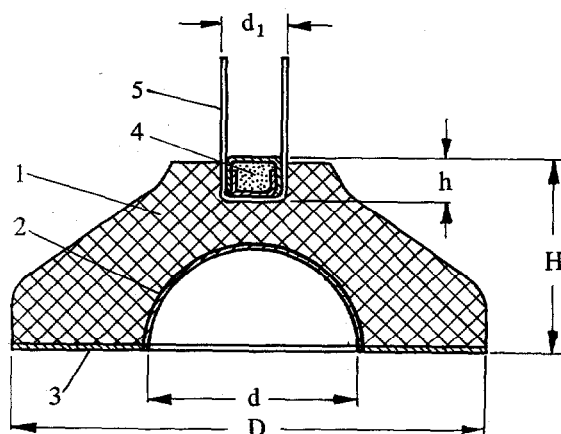

- 1 - Explosive Charge
- 2 & 3 - Steel lining
- 4 - Load of intermediate detonator in shell
- 5 - Aluminum staple

Fig 4 External Charge of the ZKP Type (weighing up to 400 grams) with a spherical shaped recess for secondary blasting (from Ref 112)

An intermediate detonator is provided for initiation of the charge with a detonator fuse contg pressed Tetryl or Pentolite. A table on p 114 contains a listing of commercial shaped charges used for blasting with dimensions for D, d, d_1 , H and h

Shaski. Demolition and intermediate detonator charges consisting of cast or pressed HE. Ref 112, pp 34 & 116 describes the following shaski: T-400 (400g TNT); Sh-200 (200g TNT); Sh-400 (400g TNT); TG-500 [Trotil-Gheksoghen (TNT-RDX) 400g]; Tet-150 (150g Tetryl); and PT-150 (150g Pentolite). As intermediate detonators they are employed for initiating granulated and slurry expls. Some shaski consist of compressed Ammonit (see under Ammonity)

Note: The term *Shaska* can also mean *pot*, such as Dymovaya Shaska (smoke pot)

Slurry Explosives, Aqueous (Nodonapolnennyiye Vzryvchatyiy Veshchestva). Accdg to Rossi & Pozdnyakov (Ref 112, pp 46-47), slurry AN expl mixts are types of commercial expls developed and introduced in Russia in the early 1960's. They consist of expl suspensions in which the liq phase is a satd aq soln of AN (sometimes with other nitrates), thickened by adding special high polymers to the desired consistency, and in which particulates of TNT, Al, non-expl combustibles such as powdered coal, etc, are suspended. In consistency they resemble thick concrete, but their mass is more coherent and stringy. The water in the formulations render them mobile, free-flowing or plastic highly dense masses, which during the charging of drillholes readily fills the entire volume and permits them to approximate the loading density of the suspension. The water content, in addition, strongly phlegmatizes the expl, making it practically insensitive to mechanical action and only weakly sensitive to the expl impulse

In the transformation of the aq phase of the suspension thru the use of special thickening agents into a gel-like state, the expl becomes water resistant

The distinguishing feature of slurry expls are: a) high density and volumetric concn of energy (greater by a factor of 1.5 to 2.0 than

for powdered expls), as well as a high rate of energy release which provides – assuming that the blasting cavity is well-filled – the required blasting effect; b) high water-resistance, making it possible to load bore-holes of any degree of inundation; and c) relatively low cost

Among the slurry expls used in Russia are the free-flowing Akvatols 65/35 and M-15, and a gel-like MG, the latter two being metallized. The following properties of the above Akvatols are given in Ref 112, pp 49–50

Akvatol	65/35	M-15	MG
Density, g/cc	1.4-1.45	1.35-1.4	1.35-1.4
Brisance by Pb Compression Test, mm	25-28	30-34	Not Listed
Detonation Velocity, m/sec	5500	5800	5500
Trauzl Test Value, cc	350	400	520

Stifnat Svintsa ili Teneres (Lead Styphnate, Lead Trinitroresorcinate, LSt). See in Vol 5 of the Encycl, p D1277-L ff

It has been used in some Russian Detonators as a separate layer over LA, but not mixed with it as was done in the USA. LSt is much easier to initiate than LA by means of spark, heat or flame. It does not react with metals, while LA reacts with Cu (Ref 15, p 16)

The properties of LSt are given in Ref 112, p 180 under *Teneres*, and in Ref 114, p 101, under *Trinitroresorcinate Svintsa (TRRS)*

TEN. Russian designation for Pentaerythritol Tetranitrate, PETN, or Pentrit. A detailed description is given in Vol 8 of the Encycl, pp P86-R to P121-R

In Russia it was manufd by the nitration of PE, either by straight nitric acid (94%) or by mixed nitric-sulfuric acid. Straight compressed PETN was used for the manuf of "Cordeau Detonants" (detonating fuses) or as a base charge in some detonators. For example, the detonator for the 30mm incendiary shell contd 0.48g PETN as a base charge and 0.23g of a primary charge consisting of 96% Pb Azide and 4% tetracene. In the phlegmatized state, desensitized with wax, it was used for loading special ammo. There is no indication that PETN was used as

the bursting charge in projectiles, even though in Germany phlegmatized PETN nearly replaced TNT for loading small caliber antiaircraft shells and antitank grenades

Belyaev (Ref 3) detd the bp of PETN to be 270° at 15–20mm Hg, and its ΔH_{evap} as 23kcal/mole

Refs: 1) Shilling (1946), p 95 2) Blinov, Vol 1 (1948), p 19 3) A.F. Belyaev, JPhys-Chem (Russia) 22, 91–101 (1948) & CA 42, 5227 (1948) 4) F. Pristera et al, PACLR 132065-b (1951) 5) Rossi and Pozdnyakov (1971), p 180 (listed as Ref 112) 6) Gorst (1972), pp 131–32 (listed as Ref 114)

Tetratsin (Tetracene). Used as a substitute for MF in some priming compns for percussion caps (chiefly mixed with LSt). One such mixt, known as "Nakol'naya smes'" (needle action compn), consisted of Tetracene, LSt, Ba nitrate and Sb sulfide; it was used in M-1 detonators

Refs: 1) Shilling (1946), pp 144–47 2) Blinov, Vol 2 (1949) 3) Gorst (1972), p 101

Tetril (Tetryl). Its manuf was begun in Russia in 1910 at the Shlissel'burgskii Zavod (Shlisselburg factory) by the action of sulfuric-nitric acids on dimethylaniline. It was used during WWI and WWII in compressed form as a base charge in detonators, boosters and in some detonating fuses. A detailed description of the Russian method of prepn is given in Ref 1

Refs: 1) Shilling (1946), p 90 2) Blinov, Vol 2 (1949) 3) Gorst (1972), pp 136–37

Tetrytoly (Tetrytols). Blends of Tetryl and TNT in various proportions

Tetrytol-Cyclonite Explosive. Prepd by melting Tetrytol and adding Cyclonite to the melt so that the resulting compn contained Tetryl 11.7, TNT 16.4 and Cyclonite 71.9%. This mixt was cast loaded into 76.2mm APHE shell

Ref: Anon, PB Rept 11544 (1945)

Note: The knowledge that employing ternary mixts of expls resulted in greater power and

higher brisance than available with *binary* mixts was gleaned by the analysis at PicArnsn of Russian 76.2mm APHE shells. The knowledge gained lead to the production in the USA of a ternary castable formulation named **PTX-1**, contg Tetryl 50, RDX 30 and TNT 20% (Ref 88a, p 409)

Trotil ili Tol (Trinitrotoluene, TNT). The first TNT plant was built in Russia in about 1907, but it took several years before compressed gun-cotton and Melinit, used for filling most projectiles, were completely replaced by TNT. Straight cast TNT has been used as a bursting charge in shells, hand grenades, and in demolition charges. It was also used in mixts with oxidizers, other expls, and powdered metals such as Al. The following are examples of such mixts: Amatols, Ammonal, K-Splav, L-Splav, Cyclotols (TNT/RDX—80/20, 60/40 and 50/50%), mixt with RDX and Tetryl (TNT 16.4, RDX 71.9, Tetryl 11.7%), mixt of TNT with Ba nitrate and Al (TNT 14.7, sulfur 0.3, Al 46.1, Ba nitrate 38.9%), etc. A mixt of TNT 60 and K nitrate 40% was used in some hand grenades

Accdg to Rossi and Pozdnyakov (Ref 112, p 39) Trotil in granulated form is called *Granulotol*, while its granulated melt with Al is referred to as *Alymotol*

Refs: 1) A.B. Shilling, *PATR 1497* (1945) 2) Shilling (1946), pp 79–85 & 95 3) Anon, "Allied and Enemy Explosives", Aberdeen Proving Ground (1946) 4) Blinov, Vol 1 (1948), p 17 5) Gorst (1972), pp 133–35

Uglenity ili Ooglenity (Uglenits). Coal mining expls allowing greater safety of operation in firedamp and coal dust environments. The following compns are listed by Rossi and Poznyakov (1971) (Ref 112):

pp 102–105 — *Uglenit E6* is an AN based expl; a friable powder oily to the touch. It is classified as an ion-exchange safety expl because its compn includes an exchange salt pair, NaNO_3 and NH_4Cl , and a small amount of KCl as a supplementary flame inhibitor. It is sensitized with a low melting mixt of nitroesters (14%), and waterproofed with Ca stearate. Its d is 1.1–

1.25g/cc; Brisance by Pb compression test, 7mm; and Trauzl Test value, 130cc

p 106 — *Uglenit No 6* is a nitroester—AN expl, permitted for permanent use in mines of all categories as well as in strata that are hazardous because of sudden gas eruptions. Its compn and props are not given

pp 102 & 106 — *Uglenit No 5* is an AN based expl; a friable powder oily to the touch. It contains a mixt of low melting nitroesters as sensitizer, and is permitted for use in coal mines. Its d is 1.1–1.35g/cc; Brisance by Pb compression test, 4mm; and Trauzl Test value, 50–90cc

pp 102 & 111 — *Uglenit No 7* is an AN based expl permitted for coal blasting with blasthole charges in mines of all gas and dust danger categories. Its compn is not given, but its props are: d 1.1–1.3g/cc; Brisance by Pb compression test, 3m; and Trauzl Test value, 80cc

VV (written in the Russian alphabet as **BB**). Abbr for *Vzryvchatyye Veshchestva*, which means Explosive Substances or Explosives

Zernogranoolity. AN based granulated water-resistant expl mixts for blasting rock of moderate hardness and for hard rock in flooded faces (Ref 112, p 37). Properties, but no exact compn of *Zernogranoolit 79/21* are given on pp 80–81 for the expl mixed hot: Brisance by Pb compression test, 22mm; and Trauzl Test value, 370cc. Corresponding values for the cold mixed expl are slightly lower, 20mm and 365cc, respectively

Properties, but no compns for *Zernogranulits 50/50-B* and *30/70-B* are given on pp 41–43: d 1.35 and 1.35g/cc; Brisance by Pb compression test, 23 and 24mm; and Trauzl Test values, 340 and 330cc, respectively

Gorst (Ref 114, p 142) gives the following compn for *Zernogranulit 30/70*: AN (granulated) 30 and TNT (flaked) 70%

Zhirov's Explosives. Several expl mixts based on Tetryl were proposed by N.F. Zhirov: (1) Tetryl 100p and Amm perchlorate 150p are moistened with a mixt of NH_4OH and acet, ground, mixed and dried; (2) Tetryl 100p and

K perchlorate 120p are treated as above
 Ref: N.F. Zhirov, RussP 4283 & 4284 (1927)
 & CA 22, 4821 (1928)

Written by B. T. FEDOROFF

**References for Russian Explosives and
 Related Items**

- 1) M. Sukharevskii & F. Pershakov, "Kurs Teorii Vzryvchatykh Veshchestv" (Course of Theory of Explosives), Gosizdat, Moscow (1932)
- 2) N.A. Sokolov, "Teoriya Vzryvchatykh Veshchestv (Theory of Explosives), ONTI, Moscow (1937)
- 3) A.G. Gorst, "Khimiya i Tekhnologiya Nitrosoyediniy" (Chemistry and Technology of Nitrocompounds), Oboronghiz, Moscow (1940)
- 5) N.A. Shilling, "Kurs Dymnykh Porokhov" (Course of Smoke Propellants), Oboronghiz, Moscow (1940)
- 6) G.K. Klimenko, "Metody Ispytaniya Porokhov" (Methods of Testing Propellants), Oboronghiz, Moscow (1941)
- 7) P.F. Bubnov & I.P. Sukhov "Sredstva Initsirovaniya" (Means of Initiation), Oboronghiz, Moscow (1945)
- 8) I.P. Karpov, "Sredstva Initsirovaniya" (Means of Initiation), Oboronghiz, Moscow (1945)
- 9) Anon, "Russian Military Dictionary", US War Department Technical Manual **TM30-544** (1945); US Government Printing Office, Washington, DC, reprinted in 1955
- 10) Anon, "Allied and Enemy Explosives", Aberdeen Proving Ground, Maryland (1946)
- 11) N.A. Shilling, "Vzryvchatyie Veshchestva i Boyepripassy" (Explosives and Ammunition), Oboronghiz, Moscow (1946)
- 12) L.A. Gallahan, "Russian-English Technical and Chemical Dictionary", Wiley, NY (1947)
- 13) Ya.B. Zel'dovich et al, "Kurs Teorii Goreniiya Detonatsii i Vzryva" (Course in the Theory of Combustion, Detonation and Explosion), Moskovskii Mekhanicheskii Institut, 2 Vols (1947)
- 14) A.I. Gol'dbinder & K.K. Andreev, "Antigriseutnyie Vzryvchatyie Veshchestva" (Permissible Explosives), Ugletekhizdat, Moscow (1947)
- 15) A.D. Blinov, "Kurs Artillerii" (Artillery Course), Voenizdat, Moscow, 12 Vols (1948-1950). Vol 1 (1948) describes Explosives and Ammunition; Available from Library of Congress, Washington, DC
- 16) B. Kubalov et al, "Vzryvnoye Delo Nauchno-Tekhnicheskoye Gornoye Obschestvo, Sbornik (Explosives Industry Scientific-Technical Mining Society Collection), No 43 (1949) (280 pp)
- (Historical description of the development of the explosives industry in Russia)
- 17) M.E. Serebriakov, "Kurs Vnutrenney Ballistiki" (Course of Interior Ballistics), Oboronghiz, Moscow (1949); Abbreviated English Translation by Dr V.A. Nekrassoff, formerly of Aberdeen Proving Ground, Maryland
- 18) R. Marsh, "How Good is Soviet Ordnance?", Ordnance **35**, 75-81 (1951) (Discusses Russian Ordnance as judged by weapons captured during the Korean War of 1950-1953)
- 19) G.M. Chinn, "The Machine Gun", Bureau of Ordnance, US Navy, Washington, DC; Vol 1 (1951) & Vol 2 (1953)
- 20) Anon, "Soviet Projectile Identification Guide", US Dept of the Army Technical Manual **TM30-240** (1953)
- 21) Anon, "German Explosive Ordnance (Projectiles and Projectile Fuzes)", US Dept of the Army Technical Manual **TM9-1985-3** (1953); pages 426-31, 482, 510, 511 & 518 (Russian Artillery Ammunition captured by the Germans during WWII)
- 22) G. Underhill, "New Soviet Arms", Ordnance **38**, 231-37 (1953)
- 23) Anon, "Materiel in the Hands or Possibly Available to the Communist Forces in the Far East", Headquarters US Armed Forces Far East Military Intelligence Section, 2nd Edition (1953)
- 24) Anon, "Foreign Military Weapons and Equipment", US Dept of the Army Pamphlet **30-14-1**, Vol X, "Ammunition" (1953)
- 25) Anon, "Examination of Service Ammunition for Soviet MIG-15 Aircraft Guns", Air Technical Intelligence Center Report **TR-AE-26**, Wright-Patterson Air Force Base, Ohio (1953)
- 26) L.V. Dubnov, "Predokhranitel'nyie Vzryvchatyie Veshchestva v Gornoy Promyshlennosti" (Safety Explosives in the Mining Industry), Ugletekhizdat, Moscow (1953)
- 27) A.A. Shidlovskii, "Osnovy Pirotekhniki" (Fundamentals of Pyrotechnics), Oboronghiz, Moscow (1954); New Edition of 1964 is Ref 86
- 28) Anon, "Inventory of Russian Items", Aberdeen Proving Ground, Maryland (1954)
- 29) Anon, "Manual for the Identification of Shells and Shell Fragments", US Armed Forces Far East (1954)
- 30) T. Urbański, "Chemia i Technologia Materialow Wybuchowich", Warszawa, Vols 1, 2 & 3 (1954) (English translation is listed as Ref 88)
- 31) G.M. Norwitz, "Compilation of Data on the Propellant and Explosive Ingredients of Foreign Ammunition 7.62 to 37mm, Examined at

- Frankford Arsenal During 1952–1953”, Frankford Arsenal Project **TB3-0025** (1954)
- 32) M.A. Budnikov et al, “Vzryvchatyiye Veshchestva i Porokha” (Explosives and Propellants), Oboronghiz, Moscow (1955) 33) B.T. Fedoroff et al, “Dictionary of Russian Ammunition and Weapons”, Picatinny Arsenal Technical Report PATR **2145** (1955) 34) Anon, “Glossary of Soviet Military Terminology, English-Russian and Russian-English”, US Dept of the Army Technical Manual **TM-30-544**, Washington, DC (1955) 35) Ya.B. Zel’dovich & A.C. Kompaneets, “Teoriya Detonatsii” (Theory of Detonation), Gostekhizdat, Moscow (1955); Engl transl, listed as Ref 68
- 36) Anon, “Use and Installation of Boobytraps”, US Dept of the Army Field Manual **FM 5-31** (1956), pp 151–53 (Russian Boobytraps)
- 37) K.K. Andreev, “Vzryv i Vzryvchatyiye Veshchestva” (Explosion and Explosives), Voenizdat, Moscow (1956); Engl translation **OTIS 30-60**, Aberdeen Proving Ground, Maryland 38) S.F. Vaskovskii, “Prakticheskoye Rukovodstvo po Obrashcheniyu s Vzryvchatymi Materialami” (Instructions for Handling Explosive Materials), GosCheologTekhIzdat, Moscow (1957) 39) N.E. Yaremenko & B.Ya. Svetlov, “Teoriya i Teknologhiya Promyshlennykh Vzryvchatykh Veshchestv” (Theory and Technology of Industrial Explosives), PromStroyIzdat, Moscow (1957) 40) A.G. Gorst, “Porokha i Vzryvchatyiy Veshchestva” (Propellants and Explosives), GosIzdatOboronProm, Moscow (1957). New edn 1972 41) Anon, “Glossary of Soviet Military and Related Abbreviations”, US Dept of the Army Technical Manual **TM 30-546** (1957) 42) Anon, “Identification Handbook Soviet Ordnance Equipment”, US Dept of the Army Office of Assistant Chief of Staff **G-2** (1957) 43) G. Underhill, “The New Soviet Weapons”, Ordnance **42**, 57–61 (1957) 44) Anon, “Soviet Engineer Intelligence Study”, **EIS 119**, US Dept of the Army, Office of Chief of Engineers, Washington, DC (1957) 45) Anon, “Analysis of High Explosive and Propellant Samples Obtained from Captured Soviet and Communist Chinese Ammunition”, Central Intelligence Agency Report **00-T-3050004** (1957) 46) Anon, “Engineer Equipment Soviet Bloc, Group IX”, Great Britain War Office **MI-10** (1957) 47) H.A. Aaronson, “Propellant and Explosive Ingredients of Foreign Ammunition Examined at Picatinny Arsenal During 1956”, PicArnsTechRept PATR **2468** (1957) (Covers PicArns Memorandum Repts: 106, 111, 112, 113, 114, 120, 126, 127, 128, 129, 130, 131, 132 and others on Russian Ammunition) 48) K.K. Andreev, “Termicheskoye Razlozheniye i Goreniye Vzryvchatykh Veshchestv” (Thermal Decomposition and Burning of Explosives), GosEnergIzdat, Moscow (1957) 49) Anon, “Soviet Naval Guns, Ammunition and Fire Control”, Office of Naval Intelligence **ONT-27-IA**, US Dept of the Navy, Washington, 25, DC (1958) 50) Anon, “Soviet Military Symbols”, US Dept of the Army Tech Manual **TM 30-547** (1958) 51) B.T. Fedoroff et al, “Dictionary of Explosives, Ammunition and Weapons (German Section)”, PATR **2510** (1958) [Russian Ammunition and Weapons captured by the Germans during WWII are listed on p Ger 72-R (10 types of 76.2mm Shells) and on p Ger 247 (four types of 76.2mm Cannon)] 52) A.D. Yakhontov et al, “Oksilikiviy” (Oxyliquits), Metalurghizdat, Moscow (1958) 53) V.A. Assonov et al, “Spravochnik po Promyshlennym Vzryvchatym Materialam” (Handbook of Industrial Explosive Materials), Ugletekhizdat, Moscow (1958) 54) V.M. Buzinov & V.P. Savelov, “Ango-Russkii Artileriyiskii Slovar’ ” (English-Russian Artillery Dictionary), Voenizdat, Moscow (1959) 55) A.A. Vovk, “Improving the Quality of Mining Explosives”, Ugol’ Ukrainy (Coal of Ukraine), **No 12**, Kiev (1959) [US Joint Publications Research Service Translation **JPRS-3264**. Office of Technical Services **60-31/64** (1960)] 56) L.G. Bolkovitinov, “On the Theory of the Initiation of an Explosion by Falling Weight Tests”, *Doklady AkadNauk* **125** (3), 572–73 (1959) [Technical Information and Library Services Translation **TIL/T.5038**, British Ministry of Aviation, London (1959)] 57) F.A. Baum, P.P. Stanyukovich & B.I. Shekhter, “Fizika Vzryva” (Physics of Explosions), GosFiz-MatIzdat, Moscow (1959) 58) M.K. Bandurin & L.G. Rukin, “Sbornik Zadach po Teorii Vzryvchatykh Veshchestv” (Collection of Problems on the Theory of Explosives), GosIzdatOboronProm, Moscow (1959) 59) V.A. Assonov et al, “Spravochnik po Borovzryvnym Rabotam” (Handbook on Blasting Operations),

- GosGorTekhIzdat, Moscow (1960) 60) G.P. Demidyuk et al, "Investigation and Development of the Simplest Granulated Explosives", in the Collection "Vzryvnoye Delo" (Blasting Practice), No 44/1, GosGorTekhIzdat, Moscow (1960) 61) W.H.B. Smith & J.E. Smith, "Small Arms of the World", Stackpole, Harrisburg, Pennsylvania (1960), pp 566-601 62) B.S. Ilyukhin et al, "Measurement of the Shock Adiabatic Curves for Cast TNT Crystalline RDX and Nitromethane", Doklady Akad. Nauk 131 (4), 793-96 (1960) [Technical Information Library Services Translation TIL/T.5186, British Ministry of Aviation, London (1961)] 63) R.P. Antonelli, "Encyclopedia of Explosives", Ordnance Technical Intelligence Agency, Ordnance Liaison Group, Durham, North Carolina (1960) 64) G.I. Pokrovskii, "Vzryv i Jego Primeneniye" (The Explosion and Its Utilization), Moscow (1960) [Translation JPRS 5946, Office of Technical Services 60-41692, US Dept of Commerce, Washington, DC (1960)] 65) B.Ya. Svetlov et al, "Granulated Explosives for Charging Flooded Drillholes in Open-Pit Operations", in Collection "Vzryvnoye Delo", No 44/1, GosGorTekhIzdat, Moscow (1960) 66) K.K. Andreev & A.F. Belyaev, "Teoriya Vzryvchatykh Veshchestv" (Theory of Explosives), Oboronghiz, Moscow (1960) 66a) D.C. Avanesson, "Praktikum po Fiziko Khimicheskim Ispytaniyam VV" (Phisico-Chemical Tests of Explosives), Oboronghiz, Moscow (1960) 67) E.O. Mindeli & D.I. Adamidze, Breakage of Coal with High Pressure Compressed Air", in Collection "Vzryvnoye Delo", No 49/2, Moscow (1960) 68) Ya.B. Zel'dovich & A.S. Kompaneets, "Theory of Detonation", Academic Press, NY (1960) (Transln of the Russian Edition of 1955 listed here as Ref 35) 69) Anon, "Infantry Weapons and Mortars, Soviet Bloc Group III", British War Office MI-10 (1960) 70) Ye.Yu. Orlova, "Khimiya i Tekhnologhiya Brizantnykh Vzryvchatykh Veshchestv" (Chemistry and Technology of High Explosives), Oboronghiz, Moscow (1960) [Translation of Technical Documents Liaison Office MCL 844/1 & 2, WP-AFB, Ohio (1961)] 71) N.V. Kurov & U.M. Dolzhinskii, "Osnovy Proyektirovaniya Porokhovykh Raketnykh Snaryadov" (Fundamentals for Designing Solid Propellant Rocket Shells), Oboronghiz, Moscow (1961) 72) Ya.M. Paushkin, "Khimiya Reaktivnykh Topliv" (Chemistry of Reactive Fuels), Oboronghiz, Moscow (1961) 73) Anon, "Explosives and Fuses Used in Mining in the USSR", Central Intelligence Report CSLT3/699340 (1961) 74) V.V. Adushkin & A.P. Sukhotin, "Disruption of a Solid Medium by an Explosion" and B.D. Khristoforov, "Parameters of a Shock Wave and Gas Bubble in an Underwater Explosion of Charges of PETN and Lead Azide of Different Density", ZhPrikl-Mekhan i TekhnFiziki 1961, No 4, pp 99-101 & 118-27 [Joint Intelligence Bureau, Division of Scientific Intelligence Transln No 791, British Ministry of Defense (1962)] 75) M.E. Serebryakov, "Vnutrennyaya Ballistika Stvol'nykh System i Porokhovykh Raket" (Interior Ballistics of Gunbarrel Systems and Solid Propellant Rockets), Oboronghiz, Moscow (1962) 76) L.V. Dubnov, "Current Status and Prospects for Advances in Explosives for the Coal Industry", in the Collection "Vzryvnoye Delo", No 49/6, GosGorTekhIzdat, Moscow (1962) 76a) B. Belkovski & G. Dyakov, "Vzryvny Veshchestva" (Explosives), Published in Bulgarian by Tekhnika, Sofia (1962) 77) Z.G. Pozdnyakov, "Ammonium Nitrate Granulated Commercial Explosives of Plant Manufacturing Granulites and Zernogranulites", in the Collection "Vzryvnoye Delo", No 49/6 (1962) 77a) L.G. Pavlovskii et al, "Commercial Tests of the Detonites 6A, 10A and 15A", in Collection "Vzryvnoye Delo", No 49/6 (1962) 78) K.K. Andreev et al, "Teoriya Vzryvchatykh Veshchestv, Sbornik Statey" (Theory of Explosives, Collection of Papers), Oboronghiz, Moscow (1963) 79) V.A. Assonov, "Vzryvchatyie Veshchestva i Ikh Primeneniye v Gornoy Promyshlennosti" (Explosives and Their Application in the Mining Industry), GosGorTekhIzdat, Moscow (1963) 80) V.Ya. Svetlov, "Characteristics of the Explosive Transformation of Aluminum Containing Explosives", in Collection "Vzryvnoye Delo" No 52/9 (1963) 81) A.I. Gol'binder, "Laboratornyie Raboty po Kursu Teorii VV" (Laboratory Work in the Theory of Explosives), RosVuzIzdat, Moscow (1963) 82) Anon, "Sino-Soviet Bloc Explosive and Propellant Research", US Army Foreign Science and Technology Center Report 381-4002 (1963) 83) Anon, "Soviet Russia Strategic Survey" (A

- Bibliography), US Dept of the Army Pamphlet 20-64 (1963); pp 60-98 (Sources of Military Power) and 98-113 (Military Power) 84) I.T. Kolesnichenko, "Experience in the Use of the Explosive E-6 in Donbass Mines", in Collection "Vzryvnoye Delo" No 55/12 (1964) 85) A.I. Silant'yev, "Tverdiye Raketnyye Topliva" (Solid Rocket Fuels), Voenizdat, Moscow (1964) 86) A.A. Shidlovskii, "Osnovy Pirotekhniki" (Foundations of Pyrotechnics), Mashinostroyeniye, Moscow (1964), 2nd Edition of Ref 27 87) M.A. Neiverth, "Soviet Research on Liquid Explosives in the Last Decade", US Army Foreign Science and Technology Center Report, Washington, DC (1964) 88) T. Urbański, "Chemistry and Technology of Explosives", Translated from Polish, listed here as Ref 30. Vol 1, Macmillan, NY (1964); Vol 2, Pergamon Press, Oxford, England (1965) and Vol 3, Pergamon Press, Oxford, England (1967) 88a) O.E. Sheffield, "Handbook of Foreign Explosives", US Army Foreign Science and Technology Center, Munitions Bldg, Washington, DC, 20315 (1965), pp 388-428 88b) K.K. Andreev, "Termicheskoye Razlozheniye i Goreniye Vzryvchatykh Veshchestv" (Thermal Decomposition and Burning of Explosives), Nauka, Moscow (1966) 89) B.Ya. Svetlov & N.Ye. Yaremenko, "Teoriya i Svoystva Promyshlennyykh Vzryvchatykh Veshchestv" (Theory and Properties of Commercial Explosives), "Nedra" Press, Moscow (1966) 90) B.D. Rossi, "Yadovityye Gazy pri Podzemnykh Rabotakh" (Toxic Gases in Underground Blasting), "Nedra" Press, Moscow (1966) 91) L.F. Dubnov & N.S. Bakharevich, "Review of the Array of Safety Explosives in the Principal Coal-Extracting Countries", in the Collection "Vzryvnoye Delo", No 60/17, GosGorTekhIzdat, Moscow (1966) 92) N.S. Bakharevich et al, "Investigation and Testing of New Safety Explosives", Ibid, No 60/17 (1966) 93) N.S. Bakharevich et al, "Low-Deflagrating Safety Explosives", Ibid, No 60/17 (1966) 94) V.F. Starokozhev et al, "Investigation of Selectively Detonating Safety Explosives", Ibid, No 63/20 (1967) 95) V.I. Zenin & B.I. Vaynshtein, "Laboratory Method of Determining the Stability of Detonation of Explosives Intended for Group Blasting with Delay in Mines", Ibid, No 63/20 (1967) 96) R.N. Solntseva et al, "Chemically Stable Aluminum-Containing Akvatol", Ibid, No 63/20 (1967) 97) G.P. Demidyuk & B.D. Rossi, "Development of the Simplest Explosives", Ibid, No 65/22 (1968) 98) M.F. Drukovaniye et al, "Sovershenstvovaniye Burovzryvchatykh Rabot na Zhelezorudnykh Kar'yerakh" (Perfection in Blasting Operations in Iron-Containing Open-cast Pits), "Nedra" Press, Moscow (1968) 99) V.S. Gavrilov et al, "Commercial Tests of the Water-Resistant Metallized Grammond A-45", Gornyi Zhurnal, No 12 (1968) 100) D.M. Brunnikov & V.E. Khorev, "Vzryvchatyye Veshchestva, Sredstva Vzryvaniya i Mekhanizmydlya Zaryazhaniya Shpurov i Skvazhin, Primenyayemyye pri Podzemnoy Razrabotke Rndnykh Mestorozhdeniy" (Explosives Initiators, and Mechanisms for Charging Blastholes and Drillholes Used in Underground Working of Ore Deposits), TsNIItsvetmet-informatsia, Moscow (1968) 101) Anon, "Yedinyye Pravila Bezopasnosti pri Vzryvnykh Rabotakh" (Unified Regulations on Safety in Blasting Operations), "Nedra" Press, Moscow (1968) 102) H. Ellern, "Military and Civilian Pyrotechnics", Chemical Pbg Co, NY (1968) 103) M.V. Dobrovolskii, "Zhidkostnyye Raketnyye Dvigateli" (Liquid Fuel Rocket Motors), Mashinostroyeniye, Moscow (1968) 104) R.E. Sorkin, "Gas Dynamics and Thermodynamics of Solid Propellant Rockets", Translated from the Russian, Davey, Hartford, Connecticut (1969) 105) R.S. Akhmatova et al, "Russian-English Dictionary", IzdSovietEncycl, Moscow (1969), 50000 terms, 759 pp 106) Z.G. Pozdnyakov & L.M. Glazunova, "New Kinds of Granulated Explosives", Nauchnotekhnicheskii Bulletin: "Tsvetnaya Metallurghiya", No 5, Moscow (1969) 107) Z.G. Pozdnyakov & D.S. Kutuzov, "Vodonapolnennyye VV, Ikh Svoystva i Opyt Primeneniya" (Slurry Explosives, Their Properties and Experience in Their Use), TsNIItsvetmetinformatiya, Moscow (1969) 108) A.Ye. Azarkovich & A.P. Tikhimirov, "Sovremennyye Promyshlennyye VV, Ikh Otsenka i Usloviya Ratsional'nago Primeneniya na Kar'yerakh" (Modern Commercial Explosives, Their Evaluation and Conditions for Their Rational Use in Open-cast Pits), Ibid (1969) 109) B.D. Rossi & V.A. Usachev, "Opredeleniye Kolichestva Yadovitykh Gazov Obrazuyoushchikhsya pri Vzryvchatom

Prevrashchenii VV i Laboratornykh Usloviyakh" (Determining the Amount of Toxic Gases Formed in the Explosive Transformation of Explosives in Laboratory Conditions), "Nedra" Press, Moscow (1970) 110) Z.G. Pozdnyakov, "Eliminating Caking of Ammonium Nitrate Explosives", in the Collection "Vzryvnoye Delo", No 45/2, GosGorTekhIzdat, Moscow (1970) 111) V.K. Müller, "English-Russian Dictionary", IzdatSovietEncycl (1970), 70000 terms, 92 pp 112) B.D. Rossi & Z. Pozdnyakov, "Promyshlennyye Vzryvchatyye Veshchestva i Sredstva Vzryvaniya-Spravuchnik" (Commercial Explosives and Initiators—A Handbook), "Nedra" Press, Moscow (1971), 176 pp, English Translation by Leo Kanner Associates (AC) for the US Army Foreign Science and Technology Center at Charlottesville, Virginia, 22901, No AD-786785 (1973), 211 typewritten pages. Obtainable from NTIS, US Dept of Commerce, Springfield, Virginia, 22151 for \$7.25 113) A.I. Chervukhin, Editor, "Russian-English Technical Dictionary", Voenizdat, Moscow (1971), 80000 terms, 1080 pp 114) A.G. Gorst, "Porokha i Vzryvchatyye Veshchestva", (Propellants and Explosives), Izdat Mashinostroyeniye, Moscow (1972). New edition of 1957 book listed as Ref 40 115) Coll, "Spanish-Russian Military Dictionary", Voenizdat, Moscow (1973), 45000 terms, 960 pp 116) Coll, "Gornoye Delo, Tekhnologhicheskii Slovar' " (Mining Business, Technological Dictionary), "Nedra" Press, Moscow (1974), 520 pp with Alphabetical Index 117) B.T. Fedoroff & O.E. Sheffield, "Encyclopedia of Explosives

and Related Items", PicArsnTechReport PATR 2700, Dover, NJ 07801:

- | | |
|------------------------------|---|
| a) Vol 1 (1960) – AD-257-189 | } Order from
NTIS, PO Box 1553,
Springfield, Virginia
22151 at \$37.50
each Vol and \$40.00
for foreign buyers |
| b) Vol 2 (1962) – AD-422-747 | |
| c) Vol 3 (1966) – AD-653-029 | |
| d) Vol 4 (1969) – AD-745-472 | |
| e) Vol 5 (1972) – AD-768-063 | |
| f) Vol 6 (1974) – AD-011-845 | |
| g) Vol 7 (1975) – AD-019-502 | |
| h) Vol 8 (1978) – | |

Ruthenium Tetroxide. RuO_4 ; mw 165.07; yel rhomb ndles which have the odor of nitric oxide or ozone; mp 25.5° , bp 108° (decompn); d 3.29g/cc at 21° . V sol in CCl_4 ; sol in acids, alkalies, bromine, ethanol (*caution!*) and liq SO_2 ; sl sol in w. Prepn is by fusing a mixt of Ru, KMnO_4 and KOH (1/2/20 by wt); decomposing the hot ruthenate with dil sulfuric acid and then steam-distg off the tetroxide under a blanket of carbon dioxide

Ru tetroxide reacts explosively with organic compds such as ethanol, filter fibers, etc. Hence, handling and storage of the tetroxide requires perfectly clean equipment

The compd is v irritating to the intestinal tract and eyes

- Refs: 1) Gmelin, Syst No 63 (1938), 27 & Ibid, Suppl (1970), 240–47 2) G. Brauer, Ed, "Handbook of Preparative Inorganic Chemistry", 2, 2nd Edn, Academic Press, NY (1965), 1599–1600 3) Merck (1976), 1075, No 8060 4) ChemRubHdb (1978), B-153

S

S1 and S2. Ger underwater expls used extensively during WWII. Their compns were TNT 60, Hexanitrodiphenylamine 24, Al powder 16%, and TNT 67, Hexanitrodiphenylamine 8, Al powder 25%, respectively

Note: See under "Underwater Explosives" in Vol 10

Refs: 1) Stettbacher (1933), 396–401 2) Ibid (1948), 135–40 3) R.H. Cole, "Underwater Explosions", Princeton Univ Press, Princeton (1948), 147–424 4) PATR 2510 (1958), 212

S.1 (Dynamite). Same as Dynamite No 1 (European name for Guhr-dynamite contg NG 75 and kieselguhr 25%) to which not over 3% Na carbonate was added. A similar product was manufd in Engl between 1883 and 1886, called EC Dynamite

Note: See Vol 5, D1742-L and E4-R

Ref: Daniel (1902), 234 & 698

Sabot. A Fr word for wooden shoes worn by peasants in Fr, Belg, and neighboring countries. In a military sense, however, the term has been applied to the "shoe" carrier used to launch various aerodynamic shapes and subcaliber projectiles at hypervelocity speeds

The invention of the tank in WWI inevitably led to the development of weapons that would

pierce its armor plating. Early anti-tank gun projectiles achieved their effect by punching a hole in the armor, relying on their mass and velocity for penetration. This is called the "kinetic energy" (KE) attack, KE being the ability of a moving body to carry out work. An important point is that the energy is proportional to the mass of the projectile, but also proportional to the velocity squared. Thus, doubling the mass of the projectile doubles the KE, but doubling the velocity increases the KE fourfold

To obtain the maximum effect the KE must be applied to the smallest possible area of the target, and this means a long thin projectile with a maximum mass and minimum diameter, moving as fast as possible. The long, thin, heavy projectile is ideally suited to maintain its velocity as it passes thru the air, but inside the gun barrel the maximum muzzle velocity is achieved by having the largest possible diameter shell which will give the biggest base area for the gas pressure to act on (Fig 1)

Thus, there is a contradiction in requirement — maximum diameter inside the barrel, minimum diameter while the shell travels thru the air and strikes the target. This contradiction was resolved in the late 1940's with the development of an APDS (armor-piercing, discarding-sabot) round. In the APDS shell there is a central core of small diameter made of tungsten carbide, a strong material of

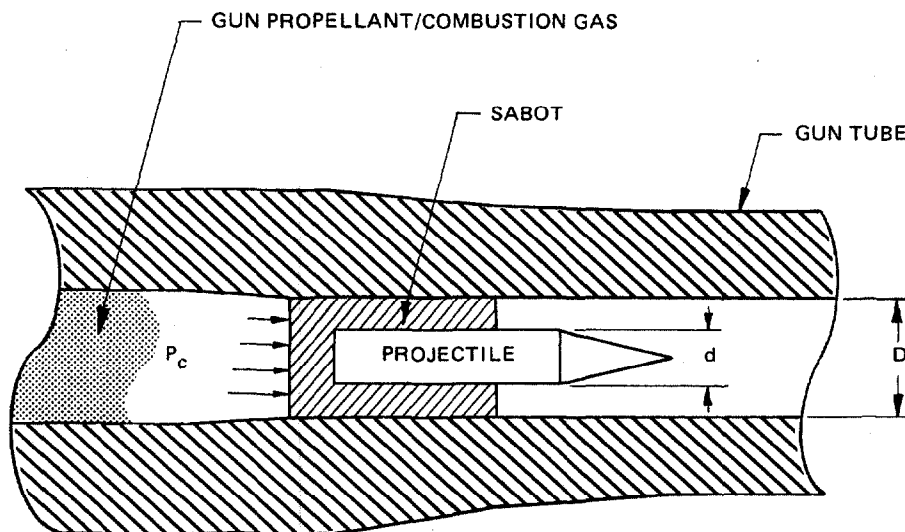

Fig 1 Sabot in Gun Tube

very high density. This is surrounded by a light magnesium alloy sleeve, or sabot, which produces a large diameter when the shell is loaded. The force of the firing breaks the sabot into sections, but the confinement of the barrel holds it together until it reaches the muzzle. The sabot then separates from the core which proceeds towards the target. Thus, at impact there is a large KE contained in a small diameter solid shot, and this produces an extremely effective attack on armor (Ref 18, pp 48-50)

In addition to being a projectile carrier, a sabot also may be designed to reinforce structurally or to protect the projectile under the high pressure, temperature, and acceleration environment in the gun bore. To satisfy its main function as a projectile carrier, the sabot not only must remain intact during bore travel, but also must serve as a gas seal. Even minute leakage of propellant gas around or thru a sabot structure is inimical because of the intense erosive power of the gas flow

Sabot Applications.

Sabot projectile applications can be grouped into two categories based upon the configuration and function of the projectile. The first group is characterized by high density, high ballistic coefficient projectiles designed for maximum impact KE, and terminal ballistic effects. Of outstanding importance in this group are KE penetrator rounds designed for defeat of medium and heavy armor. Literature review and initial analysis indicate that these configurations have been developed to a relatively high degree of sophistication on the basis of qualitative design procedures and an extensive background of experimental evaluation testing. Within this group, there are basically three different types of sabot projectiles: (1) spin-stabilized projectile with a cup sabot, (2) aerodynamically stabilized* projectile with a cup sabot, and (3) aerodynamically stabilized* projectile with ring sabot

A second group of sabot projectiles is characterized by medium- and low-density projectiles that may be gun-launched for many uses. Applications for this group include aeroballistic testing of a wide variety of aerodynamic models using light gas-gun techniques, weapon systems employing high expl and shaped charge warhead configuration, gun-boosted rockets, and a variety

of tactical and research projectiles including flares, chaff, probes, electronic packages and liquid payloads. Research studies show that fluid sabot buoyancy support techniques can provide significant structural design advantages for relatively low-density gun-launched structures. Projectile support during launch acceleration provided by the buoyancy and pressure distribution effect of the fluid can result in significant reductions in strength and weight requirements. Such projectiles, without fluid support, would be exposed to destructive acceleration loads during gun launch. Functional and design limitations imposed on buoyancy-supported projectiles are controlled primarily by configurational requirements, density, fluid compressibility, and hydrodynamic effects (Ref 17, p 1-6)

History of Sabot Use.

The Canadians were among the first to apply the potentialities of sabot-launched projectiles. The success they achieved by 1949 in the development of an APDS (armor-piercing, discarding-sabot) shot for a 20-lb cannon encouraged the USA to launch into the development of a 76mm HVAPDS (hypervelocity, armor-piercing, discarding-sabot) shot in competition with the T66 rigid shot previously under development. The expl version of this 76mm HVAPDS shot was designated the T145. It subsequently was redesignated as the M331 when accepted for use by the US Army

Until 1953, sabots were made of metal, primarily Al and Mg alloys because of their high strength-to-weight ratios. Sabot discard was achieved by designing the sabot so that when it was in the launch tube the centrifugal forces associated with spinning the sabot and projectile would expand the sabot out against the launch tube but would not fracture it. When the sabot and projectile emerged from the launch tube, removal of the radial restraint caused the sabot to disintegrate under the centrifugal loading (Ref 17, p 1-12)

In 1953, the advantages of plastic sabots were recognized and the development of a plastic version of the T145 sabot projectile, designated T89, was begun. This sabot projectile was highly successful and later became part of the M88 cartridge. Advantages of plastic sabots (Ref 1) include: (1) their strength is

* Fins or flared aft sections

adequate for many applications, (2) they cost less because they are easier to manuf, (3) they do not require critical materials, (4) they do not create as much wear on the launch tube, and (5) they break into less lethal pieces

The first plastic sabots were made of glass-fiber filled diallylphthalate sheathed in nylon and they included metal reinforcements whenever it was felt necessary to redistribute the stresses. The nylon sheath was necessitated by the abrasive nature of glass-filled materials. Nylon also is used for rotating bands on projectiles and on metal sabots. Other plastics used for the structural portions of sabots include polypropylenes, polycarbonates, celluloses, epoxies and phenolics. Polyethylene, neoprene, and silicone rubbers are used for seals and obturators

The US began development of a series of high L/D (length-to-diameter) fin-stabilized, high-density, KE penetrators in 1951. This type projectile sometimes is called an "arrow" projectile and is typified by the T320 and T208 shot series (Refs 2 & 11). Because of the high L/D ratio, the traditional cup or push sabot was inadequate and ring or push-pull sabots were developed. This type of sabot wraps around the central or forward section of the projectile, and partially pulls, partially pushes the projectile thru the launch tube. To transfer acceleration forces from the sabot to the projectile, a series of buttress-shaped, annular grooves are made on both the projectile body and mating sabot surface. These grooves interlock when the sabot and projectile are assembled. Because this type of projectile usually is fired from smoothbore guns*, centrifugal forces cannot be relied upon for separation. Ring sabots, therefore, are usually made in several segments and incorporate air scoops or bevels on the forward end of each segment so that aerodynamic forces and stored strain energy tend to peel or petal the sabot segments away from the projectile

The aft end of both ring and cup sabots also are scooped out, permitting the high gas pressures generated by the burning powder to assist in sealing against gas leakage

It also should be observed that the annular grooves on the projectile body increase its drag

*Rifled barrels have been used but it is anticipated that there is sufficient slippage between the sabot and the projectile that the latter will not develop significant spin

coefficient and, therefore, are objectionable. Aircraft Armaments, Inc. (AAI) has developed a friction-type, ring sabot and demonstrated its use in both small (cal .22) and large (152mm) caliber weapons (Refs 3 & 10)

Two serious disadvantages exist with the fin-stabilized, "arrow" projectile and ring sabot combination: (1) both the launch tube-sabot and the sabot-projectile interfaces must be sealed against gas leakage and the destructive erosion associated with gas leakage, and (2) the fins of the projectile are exposed to high temp gases during both the launch and flight portions of operation. The latter results in extreme fin ablation which is extremely undesirable. To overcome these difficulties, a series of delta-finned projectiles was developed that can be launched from a modified cup sabot (Ref 4). The modified cup sabot consists of a base plate upon which the weight of the projectile rests and four to six circumferentially spaced radial supports to position the projectile in the launch tube

The possibility of employing gun-launched rockets and space vehicles as a means of obtaining improved performance at reduced cost has not gone unnoticed. The **SPRINT** high-speed interceptor missile is a typical example of a high-performance ejection-launched rocket. It uses a modified cup sabot. Studies also indicate the feasibility of launching space vehicles 14' in diameter using a mass-restrained atomic-powered cannon (Ref 5)

In 1964, in connection with Project **HARP** (Joint United States-Canadian High Altitude Research Program), interest was expressed in launches of high-performance rockets from guns of up to 16" in bore diameter (Refs 6, 7, 8, 9 & 12). In a typical high-performance rocket motor, axial accelerations of order only 10 or 10² g can be tolerated before axial buckling causes catastrophic failure. In 1964, Lockheed Propulsion Company and Ballistic Research Laboratories (BRL) cooperated to demonstrate survivability of high-performance rocket vehicles at $\sim 10^4$ gravities acceleration in 3" to 5" bore sizes. The support technique used has been termed "fluid buoyancy support" and consists, in essence, of neutral flotation of the structure

in a gun tube, from which the rocket-containing fluid slug is expelled as a unit (Refs 14, 15 & 16)
Refs: 1) L.C. MacAllister, "On the Use of Plastic Sabots for Free Flight Testing", BRL Memorandum Rpt **MR-782** (1954) 2) E.W. Bailey, "Development of Shot, APFSDS, 90/40-mm T320 for 90mm Smoothbore Guns", APG Rpt **TA1-1475** (1957) 3) Anon, "Development of a Special Type Small Arms Cartridge (Sabot Supported) (U)", Report **ER-1414**, Aircraft Armaments, Inc (1958) (Confidential Report) 4) E. Hutchital, "Development of Delta Wing Armor Penetrating Shot (U)", Rpt 2, Electro Mechanical Research Co (Sept 1958); Ibid, Rpt **11** (March 1960); Ibid, "Design and Development of Low-Drag, High-Energy, Armor-Penetrating Projectiles (U)", Rpts **16 & 31** (March 1961) and Rpts **30 & 31** (October 1962) (Confidential Reports) 5) Anon, "Feasibility Study of a GASP Launch Payload Vehicle (U)", Rpt **RAD-SR-26-60-54**, AVCO Corp (1960) (Confidential Report) 6) G.V. Bull, "Development of Gun Launched Vertical Probes for Upper Atmosphere Studies", Canadian Aeronautics and Space Journal **10**, 236-47 (1964); Ibid, "Project HARP", Ordn **LII**, 482-86 (1968) 7) J.A. Brown & S.T. Marks, "High Altitude Gun Probe Systems for Meteorological Measurements", The Meteorological Rocket Network, IRIG Document **111-64**, (Feb 1965), pp 211-21 8) G.V. Bull, D. Lyster & G.V. Parkinson, "Orbital and High Altitude Probing Potential of Gun-Launched Rockets", Rpt **SRI-H-R-13**, Space Research Institute, McGill University (1966) 9) F.W. Eyre, "The Development of Large Bore Gun Launched Rockets", Canadian Aeronautics and Space Journal **12**, 143-49 (1966) 10) W.L. Black, "Design and Fabrication of APDS Shot (U)", Rpt **ER-4341**, Aircraft Armaments, Inc (1966) (Confidential Report) 11) S.J. Doherty, "Sabot Materials and Designs for High Velocity Kinetic-Energy Artillery Ammunition", ARMA **TR 67-11** (1967) (Confidential Report) 12) F.M. Groundwater, "The Development of Gun Launched Rockets", Rps **SRI-H-R-6**, Space Research Institute, McGill Univ (1968) 13) C.H. Murphy & G.V. Bull, "Aerospace Application of Gun Launched Projectiles and Rockets", Rpt **SRI-R-24**, Space Research Institute, McGill Univ (1968); Ibid, "Gun Launched Missiles for Upper Atmosphere Research",

AIAA Preprint No **64-18** (1964) 14) D.E. Cantey, "Gun Launch of Rocket Vehicles by Fluid Support Techniques", 3rd ICRPG/AIAA Solid Propulsion Conf, Atlantic City (4-6 June 1968) 15) D.E. Cantey, "RS-RAP Feasibility Demonstration, Phase I, Final Technical Report (U)", Rpt **953-F**, Lockheed Propulsion Co (1968) (Confidential Report) 16) D.E. Cantey & F. Saam, "F-RAP Feasibility Demonstration, Phase I (U)", Rpt **962-F**, Lockheed Propulsion Co (1968) (Confidential Report) 17) Anon, Engrg Des Hndbk, "Sabot Technology Engineering", **AMCP 706-445** (1972) 18) C. Chant, Ed, "How Weapons Work", Henry Regnery Co, Chicago (1976)

SABRE Method. Acronym for Simulated Approach to Bayesian Reliability Evaluation. An advanced approach to designing a reliability test program developed at PicArns, the objective of which was to design a test program of minimum sample size for artillery fired atomic projectiles. Called the SABRE method, the program uses mathematical modeling, Monte Carlo simulation techniques, and Bayesian statistics. It is a sophisticated system devised to test items that cannot be tested because of their atomic nature. The aim is to determine the risk factor and to predict what will happen when the projectile is fired

Economy of testing is gained thru the reduced sample sizes resulting from the integration of all available data. The users and developers risks are estimated thru the use of operating characteristics curves, which take into account how far the projectile has to go, the kill factor and the like

Reliability growth of a system is then analyzed. A model of the lowest level at which failure can be detected is developed, and results of the tests are analyzed to determine causes of failures. Current cumulative reliability estimates are computed and estimates of reliability and confidence are plotted. This analytical approach to economy testing, risk analyses and reliability growth makes SABRE a valuable tool for use in designing reliability test programs

Ref: A.J. Heyderman, "The SABRE Method: Designing a Reliability Test Program for an Artillery Fired Atomic Projectile (AFAP)", **PATR 4775** (1975)

Sabulita (Sabulites). See under "Spanish Commercial Explosives of Nonpermissible Type" in Vol 3, C442-L

Saccharose and its Nitrated Derivatives. See under "Sugars" in this Vol

Sachets Antilueurs (Fr, Anti flash Bags). See under "Argol" in Vol 1, A480-L

SADARM. Acronym for Sense and Destroy Armor. A new submunition system under development at ARRADCOM, Dover, NJ that can detect and destroy enemy tanks in massed formation. SADARM, contg a "fire and forget" antiarmor artillery projectile with self-contained target-seeking munitions, offers an antiarmor capability that has not been known before

SADARM submunitions are designed to be delivered by any of the artillery weapons already in use, making it a low cost system. The submunitions are packaged in a standard artillery projectile, and is stored, handled, loaded and fired exactly like the artillery rounds now in the field

Each submunition is equipped with a vortex ring parachute, a sensor, a processor, a warhead, a power supply, and a safe and arm mechanism. External guidance and control are not needed. Illumination of the target is not required, and the system can penetrate cloud cover or ground fog

The sequence of operations is as follows: Azimuth and range to the target are determined. The primary fuze is set and the correct amount of propellant charge is loaded into the gun to deliver the round to the area above the target. Launch setback activates the safe and arm device. As the projectile continues on its ballistic path, the pre-set primary fuze initiates when the round passes into the desired delivery area. Primary fuze initiation causes an expl pusher charge to eject the three submunitions from the aft end of the round, which continues on its trajectory. After ejection, a de-spin mechanism slows the speed to allow for parachute deployment. Once de-spin occurs, the vortex ring parachute is deployed, initiating

power supply turn-on and stabilizing the submunition to a steady drop velocity of 30 ft per sec and a rotation rate of about four revolutions per sec. The parachute's shroud lines are attached to the submunition canister in such a way that the canister maintains a 30° angle (to vertical) as it descends. This gives the sensor greater scanning coverage, and the submunition the ground coverage desired for use against multiple targets. When the sensor detects a target, it fires the armor-penetrating warhead

The SADARM system is thought to be unique because it uses a passive mm wave radiometric sensor in a high spin mode at low altitude — for the first time ever in a munition; it uses a vortex ring parachute that maintains a constant spin rate and drop velocity, and is exceptionally stable; and it delivers a long-standoff fragment warhead with armor-penetrating capability
Ref: Anon, ARRADCOM Voice (Oct 17, 1977), 7

Safeguard. US anti-ballistic missile (ABM) system proposed by the Nixon administration as a replacement for the Sentinel program first announced in September 1967. The Safeguard proposal involved the deployment, at up to 12 sites, of long and short range ABM missiles to provide a limited defense in depth against incoming ballistic or fractional-orbital bombardment missiles. Whereas the original proposals were for a comprehensive defense system giving substantial protection both to the civilian population and to the deterrent forces, Safeguard had more limited aims. Emphasis was placed on the protection of the Minuteman sites, and only light overall protection of the population would have been provided even when all sites had been completed

Safeguard incorporates two types of ABM defense called *area defense* and *terminal defense*. The area defense system is capable of intercepting ICBMs (coming over the Poles), SLBMs (from the oceans), and FOBs (fractional orbital bombardment systems) above the atmosphere at ranges of several hundred kilometers, and hence can protect large areas of the country, hundreds of kilometers across. A large, long-range radar, called Perimeter Acquisition Radar (PAR) detects and accurately tracks missiles at ranges of 1500–4000km. Based upon informa-

tion from the PAR, a long-range missile (Spartan) carrying a warhead in the megaton range with a lethal radius of many kilometers is launched to intercept the incoming missile. A smaller radar, called the Missile Site Radar (MSR), is located at the Spartan launch site and is used to steer the Spartan interceptor close to the incoming missile

Assuming some enemy penetration of the area defense system, the Safeguard design contained a second line of defense that would go into action after the effects of enemy confusion devices (chaff, metallic balloons, etc) had been dissipated. Since only a few seconds would then remain before impact, however, this second line — terminal defense — would have to employ a small and very fast interceptor missile, the Sprint. It operates in conjunction with the MSR, which sorts out the confusion devices as the missiles come into the atmosphere, and guides the Sprint to destroy the enemy missile with its low kiloton-range warhead

The Safeguard ABM system was declared operational on 1 October 1975, but the following day funding was drastically cut, and shortly thereafter Congress directed the US Army to deactivate the system

Refs: 1) E. Luttwak, "A Dictionary of Modern War", Harper & Row, NY (1971), 168–69
2) R.T. Pretty, Ed, "Jane's Weapon Systems—1977", Franklin Watts Inc, NY (1976), 28–31, 551 & 552

"Safety" Blasting Powders. Expls, also known under the names of *Carbazotine* and *Inexplosible Cahuc*, patented in Engl and Fr between 1873 and 1877. Some were manufd in Engl as late as 1897. They contained K nitrate 56 to 70, sulfur 14 to 12, lampblack 3 to 5, sawdust or tanbark dust 27 to 13, and iron sulfate 5 to 2%

In Fr, Soulage at Toulouse manufd the following mixt: K nitrate, and/or Na or Ca nitrates 52.9 to 54.3, tanbark and/or sawdust 13.2 to 15.2, sulfur 13.2 to 14.2, lampblack 14.9 to 9.8, and iron sulfate 5.8 to 6.5%

Ref: Daniel (1902), 760–61

"Safety Compound". A composite powder, consisting of K chlorate and gambier (a yellowish

resinlike astringent material derived from a Malayan woody vine, *Uncaria Gambir*), was sold after the Civil War in the oil fields of Pennsylvania for shooting wells. It was superseded by NG based expls. General H.L. Abbot, who tested it for underwater blasting applications at Willet Point, NY in 1876–77, stated that "for work under water the quickness of this powder renders it much superior to gunpowder"

Ref: VanGelder & Schlatter (1927), 28

Safety Dynamites (Ger). See under Sicherheitsdynamite in this Vol

"Safety Explosives". Expls consisting of metal cyanides (optionally of a complex nature) and salts of nitrous acid. Examples are $K_4Fe(CN)_6$ 47 and Na nitrite 53%; $Hg(CN)_2$ 73 and Na nitrite 27%; and NaCN 28 and Ba nitrate 72%
Ref: K. Eiter et al, AustrianP 176784 (1953) & CA 48, 1004 (1958)

"Safety" Gunpowder. A mixt of K chlorate and glycerine, presented before the Brit military authorities in 1888. It was not found acceptable because the ingredients partially separated in storage, resulting in an overly sensitive mixt
Ref: Daniel (1902), 760

Safety in the Energetic Materials Field

Introduction

In this article are reviewed problems associated with the safe handling of hazardous devices and materials of interest, primarily for military applications. The subject matter will be examined from the point of view of hazard prevention, of hazard assessment and of damage control. Naturally, as most such systems present some hazard, the problem becomes one of quantifying the magnitude of the risk. Hence one can describe the subject of safety as a discipline defining the degree of hazard, which determines the precautions required for avoidance of hazards and one which determines the adequacy of protection for personnel and facili-

ties. The complexity of the associated problems is increased by the recognized differences between the hazard responses and effects of expls, propmts and pyrots. Safety concerns permeate all aspects of the ordnance field. Data on hazards are diffused thruout an enormous body of literature so that this article can do little more than provide a guide to the current sources of information, with particular emphasis on the US experience. Certain large areas which are of concern to the safety engineer have been treated only cursorily. Among these are the handling and testing of liq and cryogenic propmts, the prepn of single and double base propmts, the manuf of munitions and the industrial manuf of expls because the particulars are largely a matter of technology which has been adequately treated in specific refs (Refs 20 & 58; Encycl, Vol 8, M41-L, N40-R & N56-R)

Laboratory Safety

We shall consider here a lab scale of operation to be one which deals with hazardous materials in quantities of less than 1 kg. The damage potential is therefore not a great one with respect to structures, but it will be appreciable for the exposed personnel. The hazard arises from the (presumed) unfamiliarity with developmental formulations and compds as well as from the handling of hazardous chemicals as these would be found in any laboratory operation, and which is due to the ignition of the formulation by static discharge or friction, producing a fireball and flying fragments. Death and injury are caused in a large majority of instances by burns (Ref 9), fragment impact and lung damage. Often the expln obliterates the information which could have told of the causes. In these instances the very costly method of replicating the test conditions must be resorted to until the reasons for the accident are understood and the hazardous condition is corrected (Ref 17)

Often laboratory accidents go unreported simply because serious damage was limited to the test facilities. We must therefore assume that hazardous lab conditions are, in fact, common, and that continued vigilance by the worker himself coupled with unrelenting surveillance will remain to be the best preventative. Because of the multiplicity of the causes for accidents, a discussion of lab safety practices must neces-

sarily contain a list of "do's" and "dont's"
Do Not Work Alone

Exptl or hazardous work should only be performed when two persons are present, although each person should have a separate work area assigned in order to avoid the danger of both being injured by the same accident

Do Not Smoke

Quite properly, the prohibition of matches and open flames is a universal one in expls handling labs. Most facilities have separate rest areas for the personnel which feature oversized cigarette lighters which discourage their being pocketed. Moreover, smoking should not be permitted while personnel is wearing protective clothing which is contaminated with flammable dust

Use Safety Shields

On an industrial scale, operations are commonly carried out by remote control (Ref 10) and the considerations of quantity-distance (Ref 48) and barrier design (Refs 13 & 75) apply. On a lab scale, remote weighing, mixing and pressing are usually not practical, and the protection of personnel must take the form of shielding for eyes, face and hands, as well as thru protection for the hair and the choice of suitable clothing. H. Ellern (Ref 6) remarks on the fact that self-interest is not a sufficient motivation for experienced workers to accept the requisite encumbrances of safety glasses, gloves and safety shields and that, therefore, no choice must be given to the individual regarding this matter. Complete eye shields, while desirable, are often foregone in order to make the minimum protection of ordinary safety glasses enforceable

Rubber or plastic gloves are recommended for work with acidic or caustic reagents, but these must not be worn when handling flammable materials because they melt and stick to the damaged skin. Ellern (Ref 6) prefers for pyrot work suede leather gloves which must be washed after use to prevent the impregnation with flammable or toxic matter. These are easily cleaned in lukewarm water while on one's hand. A rinse after the final soaping is omitted in order to keep the gloves flexible after drying

This author favors face shields when handling hazardous liquids, and always a suitable confinement for expansive hair styles. Stationary shields are

preferred when work is performed while seated at a work bench or when the equipment is situated in a hood. Full length shields and forced ventilation are a necessity when failure of the test might cause flying debris, a fireball or sprayed liquids. Safety showers are a necessity while safety blankets are of questionable value

Be Conscious of Fire Hazards

This article is not the appropriate place to discuss fire fighting except to remind the reader that for certain materials special fire fighting agents must be provided. W and aq cupric sulfate solns are recommended for phosphorus fires. Reactive metals must not be mixed with chlorinated hydrocarbons, instead hydrocarbons should be used for storage and degreasing. Special carbonaceous powders are marketed for smothering burning alkali metals. Proplnt and expls fires can be deluged with w, provided always that the material is not confined

Ground Your Facilities

To minimize the risk of electrostatic discharge, materials, personnel and facilities should be grounded. The source of the static charge is often the packing material unless special precautions are taken in its selection, glass bottles and jars as well as polyethylene containers are to be avoided for the pouring and shaking of dielectric liquids and powders. Pointed spatulas, particularly when these are used to scrape or dislodge dry components, are frequently found to be the cause of mishaps. Some powdered materials are best handled when moistened with w or alc (except for certain metal powders, see section on Hazardous Compounds and Systems). Work tables and floors should be covered with a grounded conductor of which a rubber based formulation (Velostat) is preferred over the use of sheet metal

Wear Protective Garments

Personnel should wear shoes with conductive soles and be grounded with the appropriate wrist and ankle straps. In an emergency, a grounded alligator clip fastened to a metallic watch band may be substituted. As a further precaution, materials should, where possible, be stored in metallic or conductive rubber containers in metal cabinets. Nylon garments should not be worn in view of their tendency to accumulate static charges. Fireproof metallized

fabrics are on the market but these induce clumsiness and are uncomfortable so that they tend to be avoided. Cotton remains the best material, especially if fireproofed. Ellern (Ref 6) recommends wool as a fabric. Polyesters have the nasty tendency to melt when hot, causing them to adhere to burnt skin. Protective garments may become impregnated with flammable materials and regular laundering should be part of the safety routine

Practice Humidity Control

This author does not favor the use of static charge meters because their use is subject to operator diligence. It is a safer procedure to avoid the conditions which promote static charge accumulation as a matter of routine. Low ambient humidity is the chief contributing factor in the accumulation of hazardous static charges. In many desert areas (which seem to be favorites for ordnance work), the daytime ambient humidity is below 20% and in temperate regions, winter-time air, and indoor air, has likewise a low humidity. For this reason, also, air conditioned air, in the absence of artificial humidification, should be strictly controlled. In order to maintain a relatively safe humidity above 50% RH, the use of evaporative coolers is helpful in a desert environment. The matter of humidity control in pyrot processing plants was recently considered by Avrami et al (Refs 55 & 56)

Miscellaneous Laboratory Hazards

Advance planning for the possibility of an accident will greatly minimize the consequences. A common hazard is found when a bench scale operation is scaled up when this scale-up occurs in an overutilized laboratory area. Solvents in small and large quantities may be found in the immediate vicinity and batches of oxidizers, expls and similar hazardous ingredients may be present where they may be exposed to ignition by one or more mechanisms. Often other personnel are present within the structure not knowing of the potentially hazardous operations which are conducted in their immediate vicinity. Exits and walk-ways may be blocked by materials, equipment or personnel in transit. While there is no safe expl, proplnt or pyrot material, familiarity does breed complacency. We are reminded of a recent expl of a BlkPdr replica plant (Ref 80) which resulted in the loss of life and the destruction of the plant. Nevertheless,

Title XI, Public Law 91-452 permits the individual antique firearms fancier to store without a license up to 50 lbs (23 kg) of BlkPdr in his home or car

Material Handling Hazards

Certain materials are a special source of hazard and their handling should be reviewed periodically

Hydrocarbon solvents, their flammability notwithstanding, are the only acceptable degreasing agents for alkali metals which are known to react explosively with chlorinated hydrocarbons such as carbon tetrachloride. This special care in the selection of wetting agents should be exercised when ball milling operations are undertaken

Most oxidizers are hazardous only when mixed with fuels. Mixts of chlorates with carbonaceous matter deserve special caution because the gaseous reaction products coupled with the exothermal decompn of chlorates cause a particularly rapid rate of flame propagation. A similar measure of care is deserved by mono-propylnts such as nitrate esters, hydrazine and organic nitro compds

Mixts of ammonium compds with chlorates may undergo an exchange reaction to form amm chlorate which is known to expld at moderate temps. No mixts of chlorates and sulfur should be prepd either wet or dry unless Na bicarbonate is added as a phlegmatizer. Red P and chlorate mixts, being the most sensitive of all pyrot systems, should only be mixed after both components are thoroughly wetted with w (Ref 6, p 51)

Water must never be used to blend mixts containing Zn, Al or Mg, nor should it be used with Ti or Zr powder unless w is in at least twentyfold excess by vol. Wet slurries, formed by settled Zr, are particularly dangerous if they are "dug out" without excess w. Water wetted metal powders have expl props when initiated with a detonator (Ref 30)

Amm nitrate (AN) is sensitized by carbonaceous matter and by metal powders. Classic is the Texas City expl of 1947 in which a 1% wax anticaking coating caused fertilizer grade AN to detonate when it was ignited (Ref 14). Today, diatomaceous earth or a similar inert material is used as anticaking material

The danger of dust explns is ever present when fuels are present in finely divided form.

Of particular concern is the handling of Zr powder which, when free of hydride, is pyrophoric in air. Wet Zr powder, when dried in vacuo, may ignite when again exposed to air. Some of the principal recurring explns take place in BlkPdr mills, and even newly developed continuous processes do not seem to be immune to this problem (Ref 66)

Toxic Hazards

The expls and pyrot industries have an abundance of toxicological hazards which are becoming to an increasing extent identified. Isocyanate curing agents can cause serious allergic reactions in sensitive individuals. Nitrate esters cause severe headaches in low concns, although personnel has been known to become addicted to these vapors causing severe withdrawal symptoms when they are denied access to them (Ref 25). Organic dyes and chromic oxides as used in pyrot smokes and signals, as well as in gasless reaction mixts, are rightly suspected of being carcinogenic. Metal chlorides, found in combustion products, are known to cause pulmonary edema upon hydrolysis in the lung tissue. Heavy metal ions of Ba and Pb can bring on chronic impairment of liver and kidney functions

Toxic hazards never seem as acute as other hazards in the ordnance industries, and the prevailing habits of cleanliness and orderliness go a long way toward their amelioration. The current emphasis on the maintenance of environmental standards have placed additional requirements on the control of effluent gas and liq process streams. The care now being exercised is evidenced by new analytical techniques for the detection of trace contaminants such as the presence of TNT and other aromatic nitrates in the soil and in the ground w (Ref 43). New techniques of detoxification have been developed using microwave plasma oxidation of aromatic compds, heavy metal compns and chemical warfare agents (Refs 65 & 81)

Table 1 is a brief listing of the toxicological properties of selected expls (Ref 18, p 3.1)

The US Navy has also investigated the use of biodegradation for the disposal of TNT containing rinse w ("pink water") (Ref 41). Likewise, the combined disposal in stabilization ponds of monomethyl hydrazine, nitrate and nitrite salts and nitrogen tetroxide waste liquors

Table 1
Toxicological Properties of Selected Explosives

Explosive	Health Hazard	Protective Measures
HMX RDX	Generally considered non-toxic Can cause convulsions resembling epileptic seizures	Proper ventilation will reduce inhalation hazard
Diethylene Glycol Dinitrate (DEGDN) Nitroglycerin (NG) Triethylene Glycol Dinitrate (TEGDN)	Aliphatic nitrates may cause dilation of blood vessels, headaches, reduced blood pressure and cyanosis; symptoms are aggravated by alcoholic beverages, absorption both thru skin and by inhalation	Proper ventilation, protective gloves, post skin absorption warning. Wash exposed skin with soap and water, not with organic solvents. Headaches appear at vapor concns below 0.2 ppm
Dinitro Toluene Trinitro Toluene	Dermatitis in sensitive individuals. Exposure to dust may irritate mucous membranes	Post skin absorption warning, max permissible concn in air 1.5 mg/m ³
Diphenyl Guanidine	Toxicology has not been investigated, but structure and high solubility in aq media is suggestive of carcinogenic properties	Protective clothing and gloves. Avoid ingestion
Lead Azide	Less toxic than Sodium Azide due to its lower solubility. Source of toxicity is the azide ion which may cause lowered blood pressure, vertigo, nausea and collapse. Cumulative damage to kidneys and spleen, may bring on fatal convulsions	Avoid ingestion, threshold tolerance value not known
Mercury Fulminate	Poisoning has symptoms of mercury poisoning. At low levels causes dermatitis and irritation of the mucous membranes	Avoid all routes of exposure. Tolerance level below 0.01 mg/m ³
Nitrocellulose	No toxic hazard, decomps to form nitrogen oxides	Use adequate ventilation

has recently been studied (Ref 73). The entire subject of biodegradation of toxic organic matter is currently a subject of great controversy, and no final consensus on its suitability for the disposal of expls wastes, which now are most commonly destroyed by open pit incineration

Prepare a Work Plan

Lastly, and perhaps most importantly, should be mentioned the advisability of preparing a work plan prior to the commencement of any hazardous activity in which the objectives and the step-by-step procedures are clearly described. In this manner the safety practices of inexperienced personnel can be supervised, and if an accident should occur, the procedure can be replicated with a minimum of uncertainty

Industrial Safety

Storage and Transport

The Dept of Transportation has combined the shipping regulations which used to be separately administered by the US Coast Guard (Title 46, CFR Part 146) and the Federal Aviation Regulations (Title 14, CFR Part 103) (Ref 46). The new regulation provides for a uniform vehicle placarding and documentation system. They replace rail express criteria with a hazard assessment for aircraft operation, and uniform criteria for all shipping modes have been established. The list of hazardous materials has been completely revised and improved directions for their use have been included. The use of prescribed colors for labels is now mandatory (Ref 46)

Sources of Safety Statistics

A useful source of data on the safety record of the transportation of expls is the Office of Hazardous Materials News, Office of the Secretary, Department of Transportation, Washington, DC. A European collection of data on industry connected accidents is said to have been collected by Dr Karl Trautzi (Ref 44). The Department of Defense Explosives Safety Board has issued two series of publications (Ref 26). The first are the proceedings of the Annual Explosives Safety Seminars. The second publication series are the abstracts of expl accidents. These reports are submitted voluntarily by both government and industry and are complete with descriptions of causes, damage and casualties. Incidents related to the Fireworks industry are reported annually in the Fire Journal (Ref 64)

Unauthorized Use of Explosives

A particular hazard originates in the unauthorized and criminal use of expls. In order to facilitate the tracing of the source of the illegally used expls, the US Bureau of Alcohol, Tobacco and Firearms has instituted a system of "tagging" expls at the time of manuf. This tagging is accomplished by the admixture of coded microparticles (Ref 63) in concns as low as 10 ppm which identify the expl, the manufacturer and the time of manuf. The tags survive detonation and can be spotted in the debris under fluorescent light for recovery with a magnet. The bureau can then trace the expl to the last point of legal sale. All thefts and losses of expl material should therefore be reported. The microtaggants are inert plastic flakes which under a microscope resemble multicolored layercakes. A given sequence of colors can be used as a code for information on the origin of the material. With 170 million possible patterns, this method can be used a long time without repeating a sequence (Ref 62)

Another problem is the detection of expls in a closed container such as a package, suitcase or aircraft baggage compartment prior to the expln. In addition to the use of trained dogs, chromatography has been investigated for this purpose (Ref 27). The presence of Dynamite in a baggage cubicle can be identified, under favorable circumstances, within about a minute. The technique requires the lowering of the

ambient pressure in the vicinity of the containers and sampling the resulting gas mixt. The applicability of chromatography to the identification of expls with low vapor pressure is questionable. The neutron activation method for detecting such expls was discussed earlier (Vol 8, N198-L ff) and found to be of doubtful value as well

Quantity - Distance Concepts

Prior to the turn of the century little was known about the theoretical and practical aspects of detonations. An empirical study of the collective experience by a joint military and railroad personnel committee had led by 1914 to the compilation of the American Table of Distances to which a table for the separation of magazines from public highways was added. This Table provided for incremental increases in distances with increasing amounts of expls, up to 250000 kg. In spite of these regulations, major disasters occurred in the transport and storage of expls and ammo. Well documented is the Lake Denmark Disaster of 10 July 1926 in which a fire following a lightning discharge initiated a magazine containing 335000 kg of expls which in turn set off others until a significant fraction of the Navy's emergency mobilization potential was wiped out - a total of 1.6 million kg of expls with a high loss in lives and injuries (Vol 6, E374-R to E377-R). This accident resulted in a further refinement of the Tables with particular emphasis on reducing further the risk to inhabited areas which join on expls storage facilities. Congress directed that the Secretaries of War and of the Navy appoint a Board which was to administer the proper dispersal of hazardous supplies. The Tables were revised after WWII in recognition of the availability of improved munitions and of the data gathered in additional accidental expls. The format of the Tables was most recently changed to conform with the United Nations safety standards for ammo and expls (Ref 47). Deliberations of the Safety Board are published regularly (Ref 26)

Quantity-Distance (QD) regulations are reduced to tables for the various classes of expls which make it possible for many people to use them without the necessity of full knowledge of the underlying theory. At present these Tables (Refs 16, 47 & 48) still employ English units even though current specifications are

Table 2
Comparison of Safety Classifications

Commodities	SCG	New Classification (Ref 47)	DOT Classification (Ref 46)	Old Military Hazards Class (Ref 16)
Initiating explosives	A	1.1	A	7
Detonators and initiating devices	B	1.1, 1.2 or 1.4	A or C	3, 4, 5, 6, 7
Bulk propellants, propellant charges, devices containing propellants with and without means of ignition	C	1.1, 1.2, 1.3 or 1.4	A, B or C	1, 2, 3, 4, 5, 6, 7
Black powder, HE and HE ammo with and without means of initiation and propelling charge	D	1.1 or 1.2	A	3, 4, 5, 6, 7
HE ammo without its means of initiation with a propelling charge	E	1.1 or 1.2	A	3, 4, 5, 6, 7
HE ammo with its own means of initiation with or without a propelling charge	F	1.1 or 1.2	A	3, 4, 5, 6, 7
Fireworks and illuminating incendiary smoke or tear producing ammo other than ammo activated by air or water	G	1.1, 1.2, 1.3 or 1.4	A, B or C	1, 2, 3, 4, 5, 6, 7
Ammo contg both explosives and WP or other pyrophoric material	H	1.2 or 1.3	A or B	2, 3, 4, 5, 6
Ammo contg both explosives and flammable liquids or gel filler	J	1.3	B	2
Ammo contg both explosives and toxic chemical agent	K	1.2	A	3, 4, 5, 6
Other ammo, requiring separate storage	L	1.1, 1.2, 1.3 or 1.4	A, B or C	1, 2, 3, 4, 5, 6, 7
Ammo which presents no significant hazards	S	4 or none	C or exempt	N/A

metric

The United Nations safety standards for ammo and expls have been accepted by the US Government and these will certainly be imposed

on the contractors as well. The UN system of classification of hazardous materials consists of nine classes of commodities of which expls, propnts and pyrot mixts are listed as Class 1.

Table 3
American Table of Distances for Storage of Class 1.1 Explosives
 (Adapted for Metric Units from DOD 5141.4S, March 1976)

Kilograms		Distance in Meters when Storage is Barricaded		
Over	Not Over	Inhabited Building	Public Traffic Route	Separation between Magazines ($6W^{1/3}$)
—	25	58	35	7
25	50	63	38	8
50	75	67	40	9
75	100	74	44	10
100	150	86	52	12
150	200	98	58	14
200	300	110	66	16
300	400	120	72	18
400	500	130	78	19
500	750	150	88	22
750	1000	162	96	24
1000	2000	205	120	30
2000	3000	230	140	35
3000	4000	250	150	38
4000	5000	272	165	41
5000	7500	320	190	47
7500	10000	350	210	51
10000	20000	450	270	64
20000	30000	530	315	74
30000	40000	580	350	81
40000	50000	640	380	86
50000	75000	740	440	100
75000	100000	820	500	110
100000	200000	1080	640	140

The various separations as used for the old QD classes have not been changed, but new storage compatibility groups (SCG) are used with the new system. Table 2 compares the SCG with the old DOT and the old military hazard classifications. Table 3 was excerpted from the UN safety standards and lists QD values in metric units.

Another way of expressing QD values is to state them as the cube root of the expl wt because certain detonation phenomena scale according to a cube root law. One of these is the instantaneous peak overpressure with distance (Ref 11). Damage can be related to overpressure by the cube root law except with respect to damage within inhabited structures and with respect to flying debris, for both of which a square root law is more nearly correct.

D.E. Jarrett (Ref 12) describes the United Kingdom practices in these matters, while Treumann (Ref 77) discusses classification according to safety hazards in the German Federal Republic.

The protection standards for QD relationships depend on the type of structure and the type of barricade. The factor indicating the distance to be provided is called the "K" or the risk factor. The assignment of numerical values for K was likewise reviewed by Jarrett (Ref 12).

Design of Barricades

In designing effective blast protection, one must consider the type of expln. The time-pressure curves for high order detonations differ from those for flammable gas explns in the rate of rise and decay, as sketched in Fig 1 and 2 for comparable time scales, but in which the

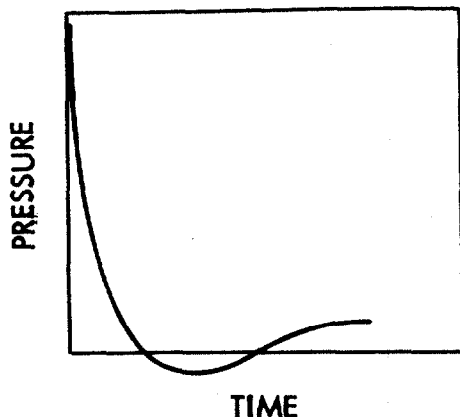

Fig 1 Schematic Pressure-Time Curve for High Order Detonation

pressure axes differ by many orders of magnitude. Hence the distinguishing feature is that the pressure rise time for a high order detonation is measured in microseconds compared with a millisecond time frame for the pressure rise from a low order expln

The effect of overpressure on the surface of a structure depends on its natural frequency. For a detonation wave the incident shock wave will be reflected at a higher level, followed by a rarefaction wave. The magnitudes of the resulting multiplication factors are presented in Ref 5 which should be consulted for further discussion of this and related subjects. Flammable gas explns do not normally give rise to amplified reflection waves. A more recent discussion on the characterization and evaluation of accidental explns was published by Strehlow and Baker (Ref 44a)

The characteristics of the two types of pressure histories which are shown in Figs 1 and 2 are also critical to the provision of effective venting. Traditional practice has been to provide a frangible wall or ceiling in expls storage or handling room in the expectation that "blow-out" would result in a reduction of the max pressure on the walls of the structure. The max pressure due to a shock driven detonation wave on the wall of a structure is a function of the amount of the expl and the distance from the wall. From Fig 1 we see that the max pressure is reached virtually instantaneously and no amount of venting will change the max pressure.

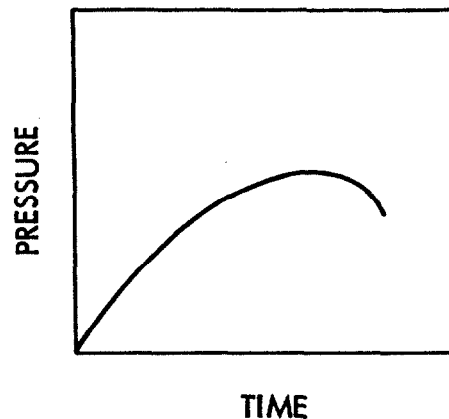

Fig 2 Schematic Pressure-Time Curve for Deflagration

Venting the shock does permit the pressure to decay and thus limit the time that the structure is stressed. A flammable gas explosion, on the other hand, can be vented as seen from Fig 2

The building of barricades is traditionally one of constructing (in the order of decreasing effectiveness) earth barricades, single revetted barricades, double revetted barricades and reinforced concrete walls. Their effectiveness has recently been called into question because large explns produce blast waves which flow over and around a barricade while shock fronts can re-form and so travel around corners. There are no recognized design procedures for barricades, prompting at least one author to recommend that "facilities should be sited without barricades until an adequate research program can develop proper design methods" (Ref 13). The results of more recent studies have been published by Katsanis and Thresher (Ref 75)

It appears that hunters have taken to using the 'O' in expls signs for target practice. A new safety rule requires that signs be no longer posted on the magazines themselves but be so positioned that a bullet fired thru them will not strike the magazine (Ref 42)

Specific Hazards

Hazardous Compounds and Systems

Much of the material presented in this section was obtained from the Feltman Research Laboratories Safety Manual (Ref 50). The information is meant as a guide toward the hazard assessment of unfamiliar systems

Table 4
Molecular Structure as a Guide to Hazard Assessment (Ref 50)

Group 1 – Radicals which Confer Explosive Properties (Plosophores)	
A. High Potential Energy Groups	
-ONO ₂	nitrate
-NH-NO ₂	primary nitramine
-NF ₂	fluoramino
=N-NO ₂	secondary nitramine
R-NO ₂	aliphatic nitro compound
Ar-NO ₂	aromatic nitro compound
Inorganic salts	perchlorates, chlorates, nitrates, bromates, chlorites and iodates
B. Relatively Low Potential Energy Groups	
-N ₃	azide
-NO	nitroso
-N=N-	diazo
-N=N-S-N=N-	diazo sulfide
-O-O-	peroxide
=N-X	halamines (X=F, Cl, Br, I)
-C=XC-	acetylenes
-O-O-O-	ozonides
Group 2 – Radicals which Enhance Potential Energy	
-CN	nitrile
=N-OH	oxime
-O-	ether

The Role of Thermochemistry in Hazard Assessment

Any compd or mixt whose heat of formation is smaller by 500 J/g (or more) than the sum of the heats of formation of its reaction products must be regarded with suspicion and handled with more than usual care. The hazards involved in working with a potentially expl system are directly proportional to the amount and to the rate of energy release. Because the reaction kinetics cannot be predicted, the propensity of a new system for expl reaction must be determined. The sensitivity of the system can be evaluated by means of impact, friction, shock and electrostatic discharge. Appropriate methods are reviewed in the Experimental and Hazard Assessment section of this article. Sensitivity to heat or elevated temp may be evaluated by use of differential thermal analysis (DTA)

or thermogravimetric analysis (TGA)

The Role of Molecular Structure Analysis in Hazard Assessment

The molecular structure of a compd can serve as a guide for the prediction of the degree of hazard. Certain groups when present in a molecule can either confer or enhance expl properties and may increase sensitivity. For the radicals listed in Table 4 the tendency to promote detonation diminishes in passing from group 1 to group 2

The mixing of Group 1A radicals in a molecule may have effects other than those expected from additivity alone. For example, nitrates are acid sensitive and are also sensitive to strongly basic groups. Thus a molecule is immediately suspect if it contains a nitrate group and either (1) a primary nitramine, primary aliphatic nitro, phenolic OH, carboxyl or other acid group, or

(2) amino, hydrazine, basic ammonia or similar basic group. In general, the potential hazard of a molecule increases with the number of radicals and especially with their variety. This is also true when an electronegative element such as chlorine or fluorine is present on the same atom as a Group 1 radical. Thus the combination $-\text{NCINO}_2$ has been found to be particularly unstable and sensitive. In the case of organic salts the hazard increases with the acid radical as follows: nitrates, perchlorates, iodates, bromates and chlorates (most hazardous). At elevated temps, however, bromates are sometimes much less stable than chlorates. Chlorites are difficult to classify, but the lower oxyacids of chlorine are quite reactive and chlorites should be considered dangerous especially when in contact with organic matter

In Group 1B are listed radicals which will make a molecule both unstable and exceedingly sensitive to impact. Many of the compds containing such groups are too dangerous to handle. The presence of groups with specific acid ($-\text{NHNO}_2$, $-\text{COOH}$), base ($-\text{NHNH}-$), oxidizing ($-\text{ClO}_3$), reducing ($-\text{NO}$), or similar group characteristics should also be noted. In general, these usually increase sensitivity and decrease stability. The presence of phenolic groups may lead to expl metal salt formation, while under certain conditions ether and carbonyl groups may form dangerous peroxides. Mixts of organic materials with inorganic salts of Group 1B acids are quite hazardous and may be sensitive to friction and impact. The acids themselves are infinitely more reactive than the salts and their formation, even from salt mixts, often leads to explns. In order to phlegmatize such mixts, fine Na bicarbonate or chalk should be added

The compatibility of various metals with expls was tabulated in an earlier Encyclopedia volume (Vol 8, M63-R to M65-L)

The Role of Oxygen Balance in Hazard Analysis

The oxygen balance (OB) is a measure of the amount of oxygen in a C-H-N-O expl required to oxidize the expln products. The OB may be reported either on the basis of oxidation to carbon monoxide or to the dioxide (Ref 23). As the OB approaches zero, the sensitivity of the expl increases and its stability decreases. Examples of OB values were tabulated in an earlier

Encyclopedia volume (Vol 8, O57-R to O62-L). The problem of chlorinated expls was also handled. There it was emphasized that, whereas the OB may be a qualitative guide in relating the energetics of the expln to the structure of the expl, there is no consistent, universally valid correlation between the heat of expln and the OB

Example: Calculate the OB of HMX, mw 296,

- (a) to form carbon monoxide



There is sufficient oxygen to oxidize the products completely, and therefore the oxygen balance is said to be zero

- (b) to form carbon dioxide

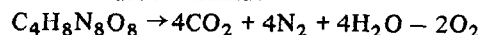

Two moles of oxygen, or 64 g/g mole of HMX are required to complete the reaction, and therefore the OB is negative by $-64/296 = -21.6\%$

Evaluation of New Explosives and Explosive Mixtures

Types of Explosives

Expls are normally classified into three categories, based on their use in munitions, as primary, booster and main charge expls. The primary expl is the most sensitive to initiation and is used to initiate the functioning sequence. The booster expl is intermediate in sensitivity and is more readily initiated than the main charge. When in doubt about the classification of an expl, it should always be treated as a primary or initiating expl until tests have clearly defined its properties as being otherwise. This classification scheme has greatest validity when applied to pure expl compds. When dealing with expl mixts deviations will almost certainly occur

Evaluation of Explosive Compounds for Laboratory Handling

A visual inspection of the structural formula of the compd - if that information is available - and a calcn of the oxygen balance will provide an initial clue concerning the probable hazard. Before more than 1 gram of a new expl is handled, it is advisable that the following sequence of tests be performed, in the order given:

- 1) Match Flame Test
- 2) Differential Thermal Analysis (DTA); see Vol 5, D1255-R to D1256-R
- 3) Thermogravimetric Analysis (TGA)

- 4) Impact Sensitivity; see Vol 7, I35-R to I55-R
- 5) Friction Sensitivity; see Vol 1, XIII and Vol 6, F204-L to F206-L
- 6) Electrostatic Sensitivity; see Vol 1, XXII
- 7) Explosion Temperature; see Vol 4, D583-L to D589-L

These tests are designed to determine whether the compd can be handled at all, and if so, with what care

The sensitivity of a compd must be determined first. Not more than one gram of a solvent wet or dissolved expl should be prepd because even this amount, if detonated in glass equipment is sufficient to kill an unprotected person. Furthermore, if groups such as the azido, diazo, $-N(Cl)NO_2$ are involved (See Table 4), the initial sample amount should be limited to 0.2 or 0.3 gram, and adequate safety precautions taken. It is advisable to keep the initial quantities wet and to remove and dry the small quantities required for each test — usually only a few milligrams

The match test is a qualitative but useful guide to the sensitivity of new compds. For this test, approx 10 milligrams of the compd is placed on the tip of a wooden handled spatula having a blade about an inch long, and the spatula is balanced over the edge of a suitable surface with the blade hanging over the edge. A small flame from a match held with a pair of tongs is then held below the blade about 2 cm from the sample. If the sample burns with flashing or if a detonation occurs, the material should be handled as an expl. Never heat any substance in a closed container

Based on the result of the match test, a DTA and TGA should be run on milligram quantities to determine their thermal stability. Steep exotherms should be taken as indications of expl hazards

The impact sensitivity should be performed on one of the customary impact testers, using again milligram quantities of the material. Bureau of Mines values of 20 or less, or Ball Drop values of the order of 100 cm or less, or PicArsn Impact Test values of 15 cm or less, all indicate that the expl be treated as a primary expl, in the class of Pb Azide or Mercury Fulminate. Such substances should be stored wet in

conductive rubber containers and the quantities should be kept small

Evaluation of Explosive Mixtures

Compns consisting of a standard expl and inert additives have properties which are essentially those of the expl. Before preparing sizable amounts of an expl mixt, a sample must be subjected to the previously described sensitivity tests. The results will give a reasonably reliable basis for deciding whether an exptl expl compn should be further evaluated

Igniters and First Fires

Igniter powders are energetic materials which can react with destructive force. Under confinement reaction is rapid and the hazard is increased from both the increased pressure and possible fragments which may result from bursting of the container. Igniter powders must burn and also have a very low brisance. These conditions limit such mixts to combinations of fuels and oxidants such as perchlorates, chlorates, nitrates, permanganates, oxides or peroxides mixed with sulfur, charcoal or aromatic compds such as naphthalene or oil

Batches ranging from 1 to 1.5g should be prepd for a preliminary evaluation of properties, as follows. All components except the oxygen carrier are placed on a conductive mat behind a barricade and mixed with a non-metallic spatula. Gloves should be worn to protect the hands. The oxygen carrier is then added, and the mixing is continued as before except that the mix is turned over with a spatula rather than being rubbed. Mixing is continued until the compn appears uniform to the eye, after which it is transferred to a conductive rubber container

If the preliminary compn is sufficiently insensitive to impact and if it has satisfactorily low brisance, the next step is to prepare a lab batch of the expl. This lot is blended by intimately mixing in a mortar, using a wooden or other non-metallic pestle, as in general metallic or porcelain pestles should be avoided. The oxygen carrier should always be added last. If a material that inherently carries a static charge is used, it should be premixed with 2–3% of one of the inorganic components that does not build up a static charge. For example, sulfur carries a static charge, and in the ordinary BlkPdr compn it is premixed with 2–3% K nitrate before it is incorporated into the main

mixt. The presence of the inorganic salt facilitates the draining of the static charge. The prepn of such test lots should always be done by remote control and personnel should not be allowed in the room while the mixer is in operation

Pressing operations must be conducted on a barricaded and grounded press, usually in a steel mold with a steel plunger using bronze plates between the plunger surfaces, for which non-sparking stainless steel is preferred. The side of the mold and the sides of the bronze plates should be cleaned before each pressing

Igniter powders should be screened in a well-ventilated area equipped with an expl proof suction fan. Due to the flammability and expl nature of the fine dust from igniter powders, no electric motors, hot plates, or other electrical equipment should be operated near the powder being screened. For drying operations, steam heat is preferred over electrical ovens

In summary, the following are the important points concerning safety in the prepn of igniter powders: 1) Do not use metallic mixing tools; 2) If foreign material is observed in the compn before or during mixing, the batch should be destroyed by wetting with appropriate solvents, for even if large contaminants could be removed, one must always assume that the mix also contains finer particles that cannot be seen; 3) Compns should not be mixed dry; 4) Igniter powders should not be ground. When crushing of the powders is required, use a wooden or conductive pestle. Work with min quantities; 5) Screw cap or glass stoppered bottles should not be used; and 6) Precautions to avoid the build-up of static charges should be strictly observed

Primary Explosive Compositions

Primary expls are the most sensitive of all chemical components in military ammo and hence the most hazardous to handle. Furthermore, single component primary expls are frequently too hazardous to handle and mixts are often used. Before the components of such a mixt are blended, the sensitivity, stability and compatibility must be tested. Reactivity increases with decreasing particle size and increasing intimacy of contact. Because primary expls are so sensitive, not more than 0.5g should be prepd initially. If a compd forms a filter

cake when being filtered, the cake should be broken up gently by means of a rubber policeman or wooden spatula with proper precautions in the form of shields and gloves. Filter cakes which cannot be broken up in this manner should be dissolved, recrystallized or reprecipitated to obtain a solid in a more tractable form. Sensitive materials should be sieved wet. For all operations conductive rubber is the preferred material for containment, followed by stainless steel, while glassware and porcelain should be avoided

In prepg the mixts, the fuels and inert materials should be blended first, after which the oxidizer can be added. Initiating agents are added last, with the usual precautions followed: grounded personnel, relative humidity above 60%, and use of barricaded, remote controlled equipment. The high sensitivity of primary expls must be kept in mind when they are being transported. Small samples, of less than one gram, should be packaged in "non-propagating" containers. These are so made that if one sample explodes, the shock will not initiate the others. Wet samples may be transported in larger quantities. Spontaneous detonation of primers has been reported (Ref 34), although the mechanism has not been established convincingly

Pyrotechnic Compositions

Pyrotechnic compns are normally mixts of finely powdered materials which, when ignited, will react and evolve a considerable amount of light, heat and smoke. Various organic binders and color intensifiers may be included in the mixts. The heat of reaction of a pyrot mixt may vary from 0.8 to 1 KJ/g and temps of 1000 to 3500° may result. More fatalities are experienced because of the effects of heat and flame than because of shock overpressure (Ref 9)

Pyrot compns vary widely with respect to their sensitivity and stability and may be very sensitive to impact, static discharge and friction. The main constituents in these compns are: 1) oxidizing agents such as chlorates, perchlorates, peroxides, nitrates, oxides, and chromates; 2) fuels such as powdered metals, silicon, sulfur and boron; and 3) organic binders and color intensifiers. Mixts contg one or more of the above substances and an oxidizing agent form pyrot compns which are likely to be sensitive to impact and friction. Decreasing particle

size of the fuel and addition of sulfur or red phosphorus generally increases sensitivity. Safety concerns of certain metallic ingredients were discussed under Material Handling Hazards

Electrical Detonators

It is neither difficult nor infrequent for an individual to accumulate 10 millijoule or more of electrostatic energy on his person. This is considerably above the threshold for initiation of a sensitive detonator. It is essential, therefore, to follow the safety procedures described below

If electric detonators are obtained without a device for shorting the metal case to the lead wires, they are to be removed from their containers and immediately wrapped with aluminum foil. Personnel, equipment, and the detonator itself must be grounded during the handling of items whose lead wires are not shorted to each other or to the metal case

RF Energy, Weapons and Lightning Hazards

The combined natural and man-made environment can be hazardous to expl devices and requires that the effects of lightning and of electrostatic discharges be considered as well as that of unwanted circuit transients such as RF energy originating from communications equipment, radar transmitters and nuclear events. System effects can vary from partial to complete dudding as well as to the premature initiation of certain types of EEDs. The many specifications relating to the RF environment have been combined into a handbook (Ref 28). Lightning poses a specific threat to certain types of ordnance devices, and the initiation hazard of detonators has been considered when these are handled in an electric storm (Ref 49)

The Handling of Nitroglycerin

The manuf of Nitroglycerin (NG) and of other nitrate esters has been described elsewhere (Refs 7 & 18), as well as in earlier volumes of this Encyclopedia (Vol 6, G99-R ff & Vol 8, N56-R ff). The principle concern in the handling of NG is the control of temp and of pH (Vol 8, N72). Spilled or contaminated material which is not suitable for use is absorbed in sawdust or fuller's earth, and burned in a remote facility. The hazardous material must remain segregated from other trash and handled only by trained personnel (Ref 50)

Biophysical Effects

Until WWII the primary interest in military

expls was in their function as fragment generators, whereas the lethal effects from blast waves were of lesser importance and which were not understood in a quantitative and theoretical sense. As the ability to deliver larger quantities of expls improved, so did the ability to damage structures and personnel from blast overpressure

Overpressure effects on structures were examined in connection with the construction of barriers and in the compilation of quantity-distance tables earlier in this article. With respect to the biophysical effects, primary blast pathology is seen in the pulmonary system. This is very much due to the violent implosion of the body wall along with the internal pressure variations which follow the initial shock front. The high mortality among initial survivors is a measure of the lack of effective therapy for the injured. Indirect blast effects include the injuries caused by the impact of projectiles and fragments and by the consequences of whole body displacement, and the contact with thermal radiation and the ingestion of toxic materials. The biomedical criteria for the primary blast effects on humans are presented in Fig 3. The problem of calculating the magnitudes of the blast overpressures for various types of expls as a function of their quantity and the distance from the source as well as the initial fragment velocities, has been presented with the assistance of nomograms and the tabulation of expls characteristics (Ref 11)

Safety Hazards of Solid Propellants

One of the major problems associated with advanced solid proplnts is their susceptibility to detonation. Motors containing such proplnts must necessarily be considered to be high expl devices and as such they must be treated with attendant restrictions in handling, storage and transportation

A commonly accepted hypothesis utilized in explaining this tendency toward detonation in solid proplnts is the grain deflagration or surface combustion mechanism. Processes which enhance internal surface formation such as internal gas evolution and creep induced strains can be expected also to increase the tendency toward deflagration to detonation transition (DDT). The DDT phenomenon in solid proplnts was examined in some detail in Encycl Vol 4. It is believed that the build-up of internal pressures

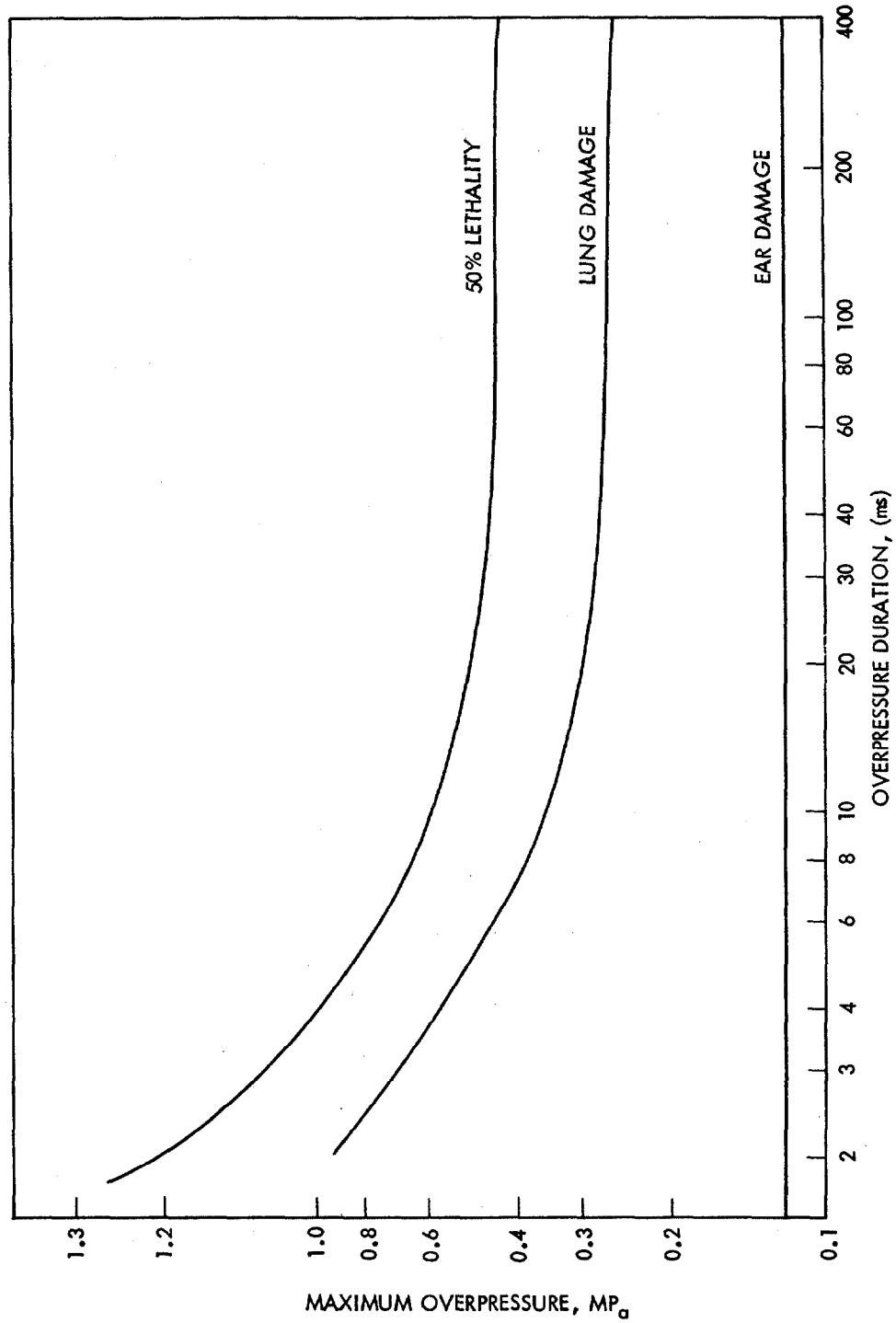

Fig 3 Biomedical Criteria for Primary Blast Effects on Humans
 (D.R. Richmond et al, "The Relationship between Selected Blast Wave Parameters and the Response of Mammals Exposed to Air Blast", See Ref 8, pp 103-121)

during burning can readily result in the formation of a shock wave. This DDT mechanism is believed valid for both homogeneous expls such as PETN, double base proplnts and modified composite proplnts. While DDT is not completely understood (Ref 71), it is commonly associated with mechanical failure of the proplnt. Internal shear failure, shear failure at the proplnt/casing interface, and tensile microfracturing due to frangibility are evidence of a potential problem. This increase in internal surface may be gradual, as due to age induced partial decomn, or sudden as due to pressurization upon ignition. Of particular concern is the presence of weakly bonded oxidizer particles such as HMX or Amm Perchlorate which act as crack starters under tensile stress. These cracks nucleate by debonding. When the proplnt is suddenly stressed, these cracks are believed to grow at size dependent velocities until they coalesce to form fragments. During this process the internal surface to volume ratio increases abruptly. For instance, a recent study (Ref 71) showed that in a highly loaded modified composite proplnt tensile stresses of a few hundred MPa with a duration of 1 μ sec produced about 2000m² of new surface per cubic meter of proplnt

If these findings are correct, then the oxidizer particle size and the solids loading fraction are a measure of the size and the concn of microcracks. Consequently much effort has been devoted to the development of new techniques for the study of microporosity. Earlier studies depended on X-ray examination, a method which does not flag a potential problem until cracks have grown to macroscopic size. Most recently (Ref 70) ultrasonic damage measurements have been performed in uniaxial compression and shear tests. A quantitative model has been developed which has shown that estimates of the size of the vacuoles arising from the dewetting of simulated composite proplnts are in excellent agreement with independent microscopic evidence. Time dependent void growth at constant strain has also been observed by ultrasonic techniques

In addition to the above microcracking phenomena, the avoidance of brittleness is a major concern in the formulation of proplnts. Brittleness and frangibility is enhanced by high

solids loading and by low temp

At one time it was believed (Ref 3) that detonability was detd by the burning rate. It must be understood clearly that high order detonation is a bulk phenomenon and not one governed by the classic proplnt burning theories. The tendency to detonate is a characteristic intrinsic with each formulation which must be studied in shock environments as it is found in a card gap or flyer plate test (see later in this article) or Susan and Wenograd tests (Ref 19)

Likewise, density is not a useful measure of the detonability of a proplnt except perhaps to the extent that low density formulations may be porous. A more valid measure of the safe-life of proplnts is the depletion with time of stabilizers such as the nitroamines which are found in double base proplnts or the loss of the plasticizer. Such determinations can now be performed routinely in a quantitative fashion by means of liq chromatography

Nuclear Radiation Hazard

α , β , γ radiation, pulsed electron beams and fast and slow neutrons have been used to determine the effect of nuclear events on expls and proplnts. While the radiolytic effects depend greatly on the material in question, no initiations have been observed due to radiation effects alone, even in primary expls. The radiolytic effects correlate with the absorbed energy and give rise to gas evolution, weight loss, density changes, etc. The subject of radiation effects on Azides and secondary expls was most recently reviewed by Avrami and Haberman (Ref 60) and on proplnts by Avrami, Loughran and Wahlberg (Ref 69). Furthermore, the general subject is reviewed in the article on Radiation Effects on Explosives in this Vol of the Encycl

Application of Computer Programming to Hazard Analysis

Much effort is being invested on the development of computer programs for the prediction of initiation thresholds of expls and proplnts but none to date are satisfactory because of the lack of a clear threshold criterion. Shock induced mechanical failure (spall) has been correlated with stress and time by varying the thickness of the flyer plates. Likewise Walker and Wasley (Ref 15) have attempted to use a P^2t criterion (where P is the scalar shock pressure

as measured by a transducer and t is the pulse-width). For a test of the Walker and Wasley criterion see Refs 35 & 51. An alternate criterion (Ref 31) attempts to use the temp-time product because adiabatic compression by means of shock waves brings about large temp spikes which, if sustained, are sure to cause ignition. This analysis requires an assumption regarding the partition of the compression energy into thermal energy and potential energy

Given a model, the analysis can be performed mathematically. A finite element computer code (Ref 38) for the analysis of finite or infinitesimal strains is now available, modified (Ref 68) to account for shock induced stresses, temp rise (by the assumption of a constant Grueneisen parameter), heat generated by the decompn of the expl and transient heat transfer. Later in this article we report an empirical treatment of proplnt initiation data (Fig 4). Analytically obtained data are in fair agreement with exptl results so that further effort along these lines appears justified (Ref 68)

The mathematical formulation of a unified initiation theory and its computerized implementation have been reported (Refs 39 & 40)

Experimental Hazard Assessment

Exptl hazard assessment depends on generally accepted tests and test devices. Many of these were reviewed in the front section of Vol 1 of this Encycl. Abroad, the European Commission for the Standardization of the Tests of Explosives is continuing the efforts toward the development of an improved state of the art, and its efforts are periodically documented in "Propellants and Explosives" (Refs 61 & 72)

Thermoanalytical Techniques

Major advances have taken place in the last decade in the development of commercially available testing equipment which has greatly improved the quality and reduced the cost of exptl hazard assessment. Quantitative data now permit routine kinetic and mechanistic studies of expl and proplnt reactions. Parenthetically should be mentioned the significant changes which have taken place in gas and liq chromatography which allow the separation of unstable expl process intermediates and reaction products. The identification of such reactive fractions is made possible by on-line mass spectrometers

and fourier transform spectrophotometers, while the acquisition and storage of digitalized data output has made possible vastly improved data bases for further refinements in theoretical analysis. Whereas these techniques are not thermoanalytical, they can be of significant value in some aspects of hazard assessment. The exptl tools described below are the principle ones in a preliminary study of hazardous materials

Differential Thermal Analysis (DTA)

The differential thermal analysis of reactive materials was discussed earlier (Vol 5, D1255-R to D1256-R) which featured also a comprehensive bibliography of theoretical studies. Recent technical advances have made possible the extension of temp ranges to 2400° (Ref 78). At the same time the range of sample size has been expanded so that hazardous materials can now be examined with ease and safety. DTA remains a powerful technique for study of condensed phase reactions at very high temps such as those encountered in pyrots, ceramics and metallurgy. Improvements in differential scanning calorimetry (DSC) have largely superceded the use of DTA for the study of combustion processes. For the application of DTA to hazard analysis, see below

Differential Scanning Calorimetry (DSC)

The currently preferred method for the study of gas forming reactions as function of temp is DSC. Here the specimen and the ref sample are heated at programmed heating rates (in controlled atms, if desired) while the differential energy input to the specimens is recorded. Hence the pen movement is directly proportional to the heat capacity while the area under the curve represents the enthalpy change. New equipment is now on the market which can operate up to 1200° (Ref 79) and which is therefore adequate for expl and proplnt studies. Limitations on the use of DSC for kinetics studies of expls will be discussed under the entry "Thermochemistry" in this Vol

The use of either DTA or DSC in hazards analysis requires much caution. The position of the maxima in the exotherms depends on the heating rate. The absence of spurious peaks is not necessarily proof of compatibility of untried systems when these are stored for long durations at ambient temps. The greatest value of DSC is as a screening tool for the detection of unus-

pected reactions in new mixts and for the observation of abruptly lowered initiation temps which may be a warning of dangerous kinetic or mechanistic effects. No insight into detonation sensitivity is obtained, which requires special tests in a simulated shock environment, because detonation mechanisms differ from those of a thermal decompn, see later under Threshold Initiation Studies. A particularly powerful technique for the detection of slight changes in materials properties consists of running the variably formulated test specimen against an equal amount of material for which stability data have been obtained previously. The differential data record affords an extraordinarily sensitive measure of changes in decompn temp, induction period and reaction rate

Thermogravimetric Analysis (TGA)

By observing the rate of mass loss, insight into thermally induced reactions can be obtained. Particularly powerful for this purpose is the use of TGA in conjunction with DSC. By this technique phase changes can be distinguished from decompns and condensed phase reactions. The obtaining of slopes of decompn curves is termed Differential Gravimetric Analysis (DGA), which is an option now commonly a part of commercial equipment. The DGA curves resemble DSC curves so that an analysis of the peak-temp relationships yield important insights into the reaction mechanism. One manufacturer is marketing an app which performs both DTA and TGA on the same specimen (Ref 79). Further research using simultaneous thermoanalytical methods should produce a better understanding of hazard assessment problems, as well as answer questions on reaction mechanisms, kinetics and the role of additives, catalysts and inhibitors

Thermal Stability Tests

Self-Heating Determinations

The tendency of expls to self-heat is an important indication of a serious stability problem. Studies of this phenomenon are performed by maintaining progressively larger regular shapes of the expl or the proplnt (for example, right cylinders, cubes or spheres) at elevated temps until deflagration occurs (Refs 19 & 82). The progress of the self-heating is followed with inserted thermocouples. The critical sizes at

ambient temps can be obtained by extrapolation

In order to relate the critical size of the expl to its storage temp, an analytical solution is also available, provided that kinetic and thermal transport data are known (see below). All extrapolations of high temp data to storage temp data are subject to great uncertainty (Ref 32) which has contributed at times to a lively debate regarding the safe-life prediction of large solid proplnt motors

Kinetic data, whether they are obtained classically from isothermal decompn studies or by DSC, can be used to calculate the critical temp at which any size of an expl can self-heat to expln. The heat-balance problem has been examined by Frank-Kamenetskii (Ref 1) and by Zinn and Mader (Ref 4). The resulting relationship between kinetic and geometric factors is as follows:

$$\frac{E}{T_m} = R \ln \left[\frac{a^2 \rho Q Z E}{T_m^2 \lambda \zeta R} \right] \quad (1)$$

where:

- R is the gas constant
- a is the radius or half thickness of the shape
- ρ is the density
- Q is the heat of reaction
- Z is the pre-exponential factor
- E is the activation energy
- λ is the thermal conductivity
- ζ is the shape factor, 0.88 for infinite slabs, 2.00 for cylinders and 3.32 for spheres

Since the early work of Kissinger (Ref 2) much work has gone into the improvement of the study of the kinetics of decompn. Table 5 lists the data of Rogers (Ref 45), and additional values can be found in Vol 7, K11. Equation (1) suggests that one should be able to vary the size of the shape at will, whereas in our experience the assumption of a size independent decompn rate is not justified. Most expls decomp by an autocatalytic mechanism, particularly at the upper temp limits so that in these cases thermoanalytically obtained kinetic data are not trustworthy

In the way of illustration, the activation energy for mass transport is typically 35–40 kJ/mole, whereas the activation energy for expls and proplnts decompn is above 100 kJ/mole.

Table 5
Illustrative Kinetic, Thermal and Geometric Parameters (Ref 45)

Explosive	Parameters for Equation (1) in Text						
	T_m °K, Exp	a cm	ρ g/cm ⁻³	Q J/g ⁻¹	Z sec ⁻¹	E kJ mol ⁻¹	$\lambda \times 10^4$ J cm sec ⁻¹ °C ⁻¹
HMX	526–528	0.033	1.81	2000	5×10^{19}	220	29
RDX	488–490	0.035	1.72	2000	2.02×10^{18}	197	10
TNT	560–562	0.038	1.57	1300	2.51×10^{11}	144	21
PETN	473–476	0.034	1.74	1300	6.3×10^{19}	197	25
TATB	604–606	0.033	1.84	2600	3.18×10^{19}	250	42
DATB	593–596	0.035	1.74	1300	1.17×10^{15}	194	25
BTF	521–524	0.033	1.81	2600	4.11×10^{12}	156	21
NQ	473–477	0.039	1.63	2000	2.84×10^7	87.5	21
PATO	553–555	0.037	1.70	2000	1.51×10^{10}	135	13
HNS	593–594	0.037	1.65	2000	1.53×10^9	127	21

Therefore, at low temps mass and heat transport dominates the rate process, while at higher temps the decompn rate of the expl is rate determining so that extrapolation to large sizes or long storage times may in fact not be valid

Also, the assumption of homogeneity and the absence of competing thermal processes such as phase changes or polymerization is implicit in the derivation of Equation (1). Therefore, self-heating predictions do not apply to the destructive effect which results from high local concns of reactive components such as may be found in proplnt blending operations. The only known test method for assessing the hazard is to formulate deliberately such mal-mixts and to test for an exothermic effect using DSC or DTA (Ref 82)

Wenograd Test

The Wenograd test is designed to determine the expln temp under adiabatic conditions. This test is believed to be a close approximation to one in which a proplnt or expl is initiated by impact. It is performed by resistance heating of the expl material which is contained in a small diam stainless steel tube. The energy is furnished by a capacitive discharge which triggers an oscilloscope trace of the emf. From the circuit design, a tube temp is calculated. Response

times are said to be in the order of $20 \mu\text{secs}$ (Ref 19)

Taliani Test

The Taliani test is designed to determine the temp sensitivity of hazardous materials when these are stored for prolonged times. It is useful as a sensitivity criterion for double base and single base proplnts. The test is performed by enclosing approx 1 g of sample in a purged system (see Vol 1, XXV) at 1 atm N₂ at a constant elevated temp. The pressure change and rate of pressure change are plotted at regular time intervals. The application of the Taliani test in hazard analysis is limited to comparative studies with similar materials for which prior experience exists

Vacuum Stability Tests

Vacuum stability tests and other types of standard heat tests differ from the Taliani test in that they are performed in closed systems which are initially evacuated (see Vol 1, XXVI). Weight losses or quantities of gas evolved are reported for certain fixed temps over standard time intervals. These tests are empirical in that the results have meaning only in comparison with those obtained on substances whose stability is known. The hazard analysis of a new product or of a new production lot consists

therefore of comparative data on the vacuum stability. See also Ref 21 and Vol 7, H32-R to H34-L

Threshold Initiation Studies

Impact and Friction Tests

Impact and friction tests have been described earlier (Vol 1, XIII & XVII; Vol 4, D304-R; and Vol 7, I35-R to I55-R)

The reader is urged to read "Initiation of Explosives by Impact" in Vol 7, I35-R ff of this Encycl. Whereas that article dealt principally with the testing of expls, we shall want to include proplnts in the discussion. There is probably no subject in hazards analysis which is so actively studied as the role of impact, shock and thermal effects on the safety of expls and proplnts and which is as poorly understood. We have alluded to this incomplete state of theoretical development in the section of this article on Application of Computer Programming

to Hazard Analysis and found a lack of a way to partition compressive energy into thermal and potential energy. The classic way is thru the Grueneisen-type equation of state:

$$\gamma = V \left[\frac{\partial P}{\partial E} \right]_V \quad (2)$$

The Grueneisen parameter is not necessarily constant (except initially, at zero pressure), but decreases with increasing compression. The EOS for this process is not known for the shocked state, even for a homogeneous expl, much less for such a heterogeneous mixt as a solid proplnt

The response of composite proplnts to impact was studied phenomenologically by B. Brown (Ref 22). He divided the response into fracture, ignition and detonation regimes. The ignition velocity was found to be only a function of proplnt mass. His data are shown in Fig 4 to which the results of a more recent study were added (Ref 68). He also found that the yield

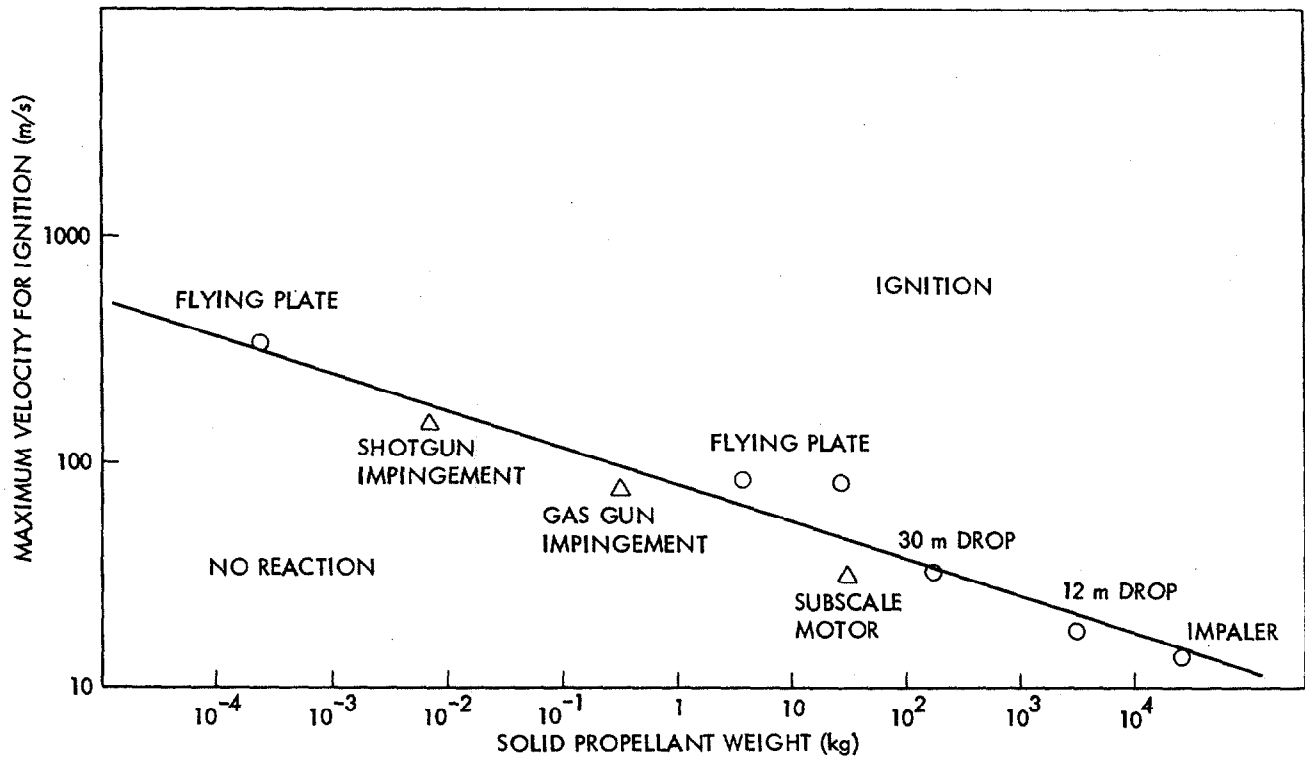

Fig 4 Ignition of Composite Solid Propellants by Impact

○ Ref 22 - △ Ref 68

increases with mass so that in fact a train or truck crash involving solid proplnts or a missile fallback constitute a large but unexplored hazard
Shock Initiation of Hazardous Materials

An attempt to obtain a relationship between the enthalpy at ignition (as estimated from a synthesized EOS) and the impact velocity at ignition was made for pyrot mixts by Hardt and Martinson (Ref 37). The reader is directed to the article on shock initiation in this Vol of the Encycl for a more detailed analysis. Two specific shock initiation tests, the Susan Test and the Card Gap Test, are referenced below. An excellent review of the shock physics of expls is found in one of the Engineering Design Handbooks (Ref 29). A predictive initiation model remains an elusive goal, but one under continuing study (Ref 52). A very careful measurement of the Hugoniot and shock initiation threshold of Pb Azide was made by Davies et al (Ref 53). This study is significant because it provides insight into the requirements of an initiation model. Characteristics of primary expls that account for their action as primaries were identified (Ref 74) by correlating their physical and chem properties with their molecular structures. This goal has been attained in a qualitative sense

Susan Test

The object of the Susan Test is to compare the relative sensitivity of proplnts and expls under conditions of impact. It is performed by impacting a confined specimen at high velocities onto a steel plate. The driver is a 3-inch gun which imparts velocities ranging from 30 to 40m/s to the projectile. The results in terms of the kinetic energy of the projectile required for initiation are only of empirical value for reasons stated above (Ref 18, pp 2-20)

Card Gap Test

The card gap test is one of the important tests that has been accepted by the explosives industry to distinguish between a material classified as mass detonating, Military Class 1.1, and a material classified as a fire hazard only, Military Class 1.3 (Ref 47). The card gap test has been described in earlier sections (Vol 6, G13-R ff), as have other tests on detonation and explosion criteria (Vol 4, D299-R ff)

Electrostatic Sensitivity Tests

There is no standard electrostatic sensitivity test equipment but the basic components of any

app are the same in that they include a high voltage power supply, a capacitive charging circuit, a triggering circuit, an electrode assembly and an electrostatic voltmeter. Two methods are commonly used to measure the minimum energy for initiation: the fixed gap and the approaching electrode methods

In the fixed gap method two electrodes (having either a needle plane, a sphere plane or a parallel plane configuration) are placed a fixed distance apart, although the distances are not standardized. The storage capacitor, charged to the desired voltage, is discharged by means of a fast electronic switch. The resulting spark energy becomes then the measure of the threshold energy for initiation

There is no switch in the approaching electrode method. The gap between the electrodes is successively narrowed until discharge takes place at the applied voltage

In either test, the applied voltage and the capacitance are used to compute the threshold energy:

$$E = 1/2 CV^2 \quad (3)$$

It is not possible to learn the discharge energy directly from a current-voltage record across the gap because the electrical properties of the plasma cannot be described accurately (Ref 36). Moreover, the circuit constants differ for each app. For high impedance systems, the discharge efficiency (ie, the spark or discharge energy as compared with the total energy stored in the circuit) is only in the order of 10-14% (Ref 59). If contact between electrodes is permitted, contact discharge can occur at voltages which are very much lower than those found in the gap discharge. This contact voltage is the primary cause of concern in the handling of primary expls for which initiation energies as low as 1.5×10^{-6} J are reported (Ref 59). Primary expls present an additional source of hazard in having their sensitivity affected by the magnitude of the electric field. The dielectric breakdown potential for Pb Azide is reported to be as low as 30 KV/cm, if the electrode contacts the expl. The reader is directed to H.D. Fair's and R.F. Walker's work on energetic materials (Ref 58) for a current and exhaustive appraisal of this subject. A safety film pointing out the hazards and the control of static electricity has also been prepared (Ref 24)

A special type of an electrostatic discharge test is one which seeks to determine dust explosibility (Ref 18, pp 2-13). This author has never seen any data which proves this test to be of any particular value in establishing a threshold initiation level of certain pyrot powders such as flash compns and their ingredients such as metallic Zr powder

Control of static charge build-up can be aided by the use of conductive rubber gloves, soles, flooring and containers. A well-known brand of conductive rubber products is Velostat

A study of static charge build-up on the human body in an arctic environment and how it might affect initiation of primers was reported recently (Ref 57). For an earlier discussion of charge build-up on humans see Ref 33. Operations are considered hazardous when the electrostatic energy potential during the suspected operation exceeds the threshold initiation level for the hazardous material. The human body can constitute a hazard when the material can be initiated by a discharge of less than 0.015 J, as is the case with primary expls

The measure of the electrostatic sensitivity of electro-expl devices was reviewed earlier (Vol 5, E83-R to E84-L). The threshold response of materials to an electrostatic charge is the "no initiation" energy. It is compared with the electrostatic energy which might be encountered during manufg, handling or deployment. "Rad-haz determinations" are made for the measurement of an RF field response and "electrostatic discharge human spark tests" attempt to establish the susceptibility of the energetic material to initiation when it is subjected to the electrostatic discharge generated by humans. As we have seen, this concern is especially acute when handling primers and it is the impetus for the continuing efforts to perfect safer initiators

Written by A. P. HARDT

Lockheed Missiles and Space Co, Inc

Refs: 1) D.A. Frank-Kamenetskii, *ActaPhysiochemUSSR* 10 (1939), 365 2) M.E. Kissinger, *AnalChem* 29, (11), (1957), 1702 3) H.L. Partridge, "Safety Hazards of Rocket Propellants", Report **DB-TR-13-58**, PicArnsn, Nov 1958 4) J. Zinn & C.L. Mader, *JAppPhys* 31 (1960), 323 5) Anon, "Principles and

Practices for Design of Hardened Structures" **AFSWC-TRP-62-138**, Air Force Special Weapons Center, Kirtland AFB, NM (1962) 6) H. Ellern, "Military and Civilian Pyrotechnics", Chemical Publishing Co, NY (1967) 7) T. Urbański, "Chemistry and Technology of Explosives", Vol 2, Pergamon Press, NY (1965), 62-125 8) E. Cohen, Ed, "Prevention of and Protection Against Accidental Explosion of Munitions, Fuels and Other Hazardous Mixtures", *Annals of the NY Academy of Sciences*, 152, Art 1, pp 1-913 (Oct 1968) 9) J.E. Settles, "Deficiencies in the Testing and Classification of Dangerous Materials", See Ref 8, pp 199-205 10) H.G. Johnson, "Designing Remote Control Shelters for Personnel Safety", See Ref 8, pp 585-598 11) J. Petes, "Blast and Fragmentation Characteristics", See Ref 8, pp 283-316. Also see *ChemRev* 59 (5), (1959), 801-825 12) D.E. Jarrett, "Derivation of the British Explosives Safety Distances", See Ref 8, pp 18-35 13) H.L. Callaghan, "Practical Problems in the Designing and Siting of Explosive Facilities", Ref 8, pp 61-74 14) M.A. Cook, *IEC* 60, (7) (July 1968), 44-55 15) E.E. Walker & R.J. Wasley, "Critical Energy for Shock Initiation of Heterogeneous Explosives", *Explosivst* (1), (1969), 9-13 16) Anon, AMC Regulation "Safety Manual", **AMCR 385-100** (April 1970), updated Jan 1977 17) Anon, "XMS 248 Igniter Failure" (Film), Cornell Laboratories 18) Anon, "Chemical Rocket/Propellant Hazards", **CPIA No 194** (1970), 2-13 19) *Ibid*, pp 2-3, 2-4, 2-5; also see J. Wenograd, *TrFaradSoc* 57, 1612 (1961) 20) *Ibid*, p 3-1 21) H.T. Simmons, Jr, "The Vacuum Thermal Stability Test for Explosives", US Naval Ord Lab, Report **NOLTR-70-142** (1970), AD 718806 22) B. Brown, "The Proper Hazard Classification of Solid Propellants", Paper presented at the Specialist Session on Rocket Motor Safety, 26th JANNAF Meeting, Washington, DC (1970) 23) Anon, "Properties of Explosives of Military Interest", *EngrgDesHndbk*, **AMCP 706-177** (1971), AD 764340 24) Anon, "Static Electricity" (Film), Catalogue No J 10110, Am Gas Association, Inc, 605 Third Ave, NY, NY, 10016 (1971) 25) Anon, *TIME* (July 12, 1971), 41 26) Anon, "DDESB Explosive Accident / Incident Abstracts from 1967-1971", AD 660020, AD 673013, AD 854894, AD 873145 & AD 746166

- (for a listing of the Proceedings of the Annual Explosives Safety Seminars see Table 6) 27) W.D. Kilpatrick, "Plasma Chromatography (Trademark) and Dynamite Vapor Detection", Contract DOT-FA 71-WA-2491, The Franklin GNO Corp, West Palm Beach, Florida (1971) 28) Anon, Engrg-DesHndbk, "Hardening Weapons Systems Against R.F. Energy", **AMCP 706-235** (1972), AD 894910 29) Anon, EngrgDesHndbk, "Principles of Explosive Behavior", **AMCP 706-180**(1972), AD 900260 30) A.A. Shidlovskii, "Principles of Pyrotechnics", Moscow (1973), Translation AD-A001-859 (1974), 196 31) H. Krier et al, "An Ignition Model for Solid Propellants", **TR-AAE73-9**, Aeronautical and Astronautical Engineering Department, University of Illinois (1973) 32) R. Stenson, "Prediction of the Crack Lives of Solid Propellants Due to Gas Accumulation", **AIAA Paper 73-1173**, Las Vegas, Nev (1973) 33) Proceedings of the 8th Symposium on Explosives and Pyrotechnics, The Franklin Institute, Los Angeles (Feb 1974) 34) E. Demberg, "Spontaneous Detonation of Initiators", See Ref 33, paper No 36 35) R.J. Wasley & F.E. Walker, "Critical Energy for Shock Initiation of Fuze Train Explosives", See Ref 33, paper No 18 36) A.P. Hardt et al, "Early Stages in Wire Explosions, II. Resistance Calculations", See Ref 33, paper No 45 37) A.P. Hardt & R.H. Martinson, "Initiation of Pyrotechnic Mixtures by Shock", Ref 33, paper No 53 38) S.W. Key, "HONDO - A Finite Element Computer Program for the Large Detonation Dynamic Response of Axisymmetric Solids", **SLA-74-0039** (1974) 39) H.H. Bradley, Jr, "A Unified Theory of Solid Propellant Ignition", Part I, Development of a Mathematical Model, **NWC TP 5618**, Naval Weapons Center, China Lake, CA (1974) 40) Ibid, "A Unified Theory of Solid Propellant Ignition", Part II, Computer Program, **NWC TP-5618**, Naval Weapons Center, China Lake, CA (1974) 41) G. Cohn, Ed, *Expls&Pyrots* 7, (9) (Sept 1974) 42) Ibid, (11) (Nov 1974) 43) D.F. Goerlitz & L.M. Law, "Gas Chromatographic Method for the Analysis of TNT and RDX Explosives Contaminating Water and Soil Core Material", US Department of Interior Geological Survey Open File Report **75-182** (May 1975) 44) Karl Trautzi, "International Exchange of Experience on Industry Connected Accidents of the Explosives Industries", Swiss Explosives Works, Ltd, 5605 Dottikon, Switzerland 44a) R.A. Strehlow & W.E. Baker, "The Characterization and Evaluation of Accidental Explosions", *Prog Energy Combust Sci*, Vol 2, 27-60 (1976) 45) R.N. Rogers, *Thermo-chimicaActa* 11 (1975), 131-139 46) Anon, *Federal Register* 41, (74), 15972-16131 (April 1976). Order as Publication of Docket HM-103/112, Amendments (Part II) from the Supt of Doc, Gov't Printing Office, Washington, DC 47) Anon, "DOD Ammunition and Explosives Safety Standards", Publication **DOD 5154.4S** (Mar 1976) 48) Anon, "Quantity-Distance Standards for Manufacture, Handling and Storage of Mass Detonating Explosives and Ammunition", **DOD Directive 4145.17** 49) D. Bodoroff, "Lightning Hazard to Explosives", *The Explosives Engineer* (1), Hercules Inc, Wilmington, Del (1976) 50) Anon, "Feltman Research Laboratories Safety Manual", **ARRADCOM**, Dover, NJ (1976) 51) P. Howe et al, "Shock Initiation and the Critical Energy Concepts", *Proceedings of the Sixth Symposium (International) on Detonation*, Coronado, CA (Aug 1976), 11-19; also see pp 82-94 for a full discussion of the P^2t concept 52) Y. de Longueville et al, "Initiation of Several Condensed Explosives by a Given Duration Shock-wave", see Ref 51, pp 105-114 53) F.W. Davies et al, "The Hugoniot and Shock Initiation Threshold of Lead Azide", *JChemPhys* 64, (6), 2295-2302 (1976) 54) *Proceedings of the 9th Symposium on Explosives and Pyrotechnics*, The Franklin Institute, Philadelphia, PA (Aug 1976) 55) L. Avrami, C. Davey & F.R. Taylor, "Early Detection of Potential Hazards in Pyrotechnic Processing Plants", Ref 54 56) C.T. Davey, "Methods for Monitoring Initiation Sources Generated in Pyrotechnic Processing Equipment", AD A030754 (Sept 1976) 57) C.T. Davey, "Electrostatics and the Arctic Environment", Ref 54, No 17; also see: "Human Static Machine as Related to Explosive Safety", Ref 33, paper No 29 58) H.D. Fair & R.F. Walker, Eds, "Energetic Materials", Vols 1 & 2, Plenum Press, NY (1977) 59) M.S. Kirshenbaum, "Electrostatic Sensitivity", see Ref 58, Vol 2, pp 166-198 60) L. Avrami & J. Haberman, "Sensitivity to Heat and Nuclear Radiation", see Ref 58, pp

199-247 61) H. Ahrens, "International Study Group for the Standardization of the Methods of Testing Explosives", *Propellants and Explosives* 2 (1977), 1-3 and 7-20
 62) Anon, *Business Week* (Aug 15, 1977), 44C-44D. Also see: ATF News Release FY 77, Dept of the Treasury, Washington, DC, 20226
 63) F.M. Ryan & R.C. Miller, "Phosphor Identification Method", USP 4013490 (1977)
 64) Anon, *American Pyrotechnist* 10, (3), 810-812 (1977) 65) L.J. Bailin, "Detoxification of Navy Red Dye Composition by Microwave Plasma", Environmental Research Lab, Environmental Protection Agency, Cincinnati, Ohio (1977) 66) K. Loevold, Nitedals Krudtvaerk, Norway, Private Communication 67) E.E. Gilbert, "Recovery of Organic Values from TNT Purification Waste Water", *Propellants and Explosives*, (2) (1977), 118-125 68) L.K. Baxter, "Motor Impact Ignition Level Program", Hercules-Thiokol Report 5A015-A2A00HJT-OJI (1978) 69) L. Avrami, E.D. Loughran & C. Wahlberg, "Neutron and Gamma Effects Vulnerability Study to Rocket Propulsion Energetic Materials", ARLCD-TR-78015, AFRPL-TR-77-77 & AD E400153, (1978) (not used in the write-up of this article) 70) R.H. Martinson, J.L. Bellin & R.W. Holsinger, "Damage Assessment in Filled Polymers by Ultrasonics", Paper Presented at the 15th Joint Meeting of the JANNAF Service Life Subcommittee, Monterey, CA (April 1978) 71) W.J. Murri, Y. Horie & D.R. Curran, "Fracture and Fragmentation of High Energy Propellant", SRI International Report (1978) 72) EXTEST International Study Group for the Standardization of the Methods of Testing Explosives, 7th Meeting EXTEST 76, Dalari, Sweden (June 1976), reviewed in *Propellants and Explosives* 3 (1978), 1-8 73) B.C. Cohenaur, "Disposal of Hypergolic Propellants", NASA-CR-147911 (1977) & CA 88, 91788 (1978) 74) C.M. Tarrer et al, SRI Report AD A044714 (1977) & CA 88, 123385 (1978) 75) D.J. Katsanis & R.G. Thresher, "Suppressive Shielding of Explosive Facilities", Proceedings of the Sixth International Pyrotechnic Seminar, Univ of Denver (July 1978), 273-303 77) H. Treumann, "Classification of Pyrotechnic Compositions According to their Safety Hazards", see Ref 75, pp 599-614 78) Thermoanalyzer 1,

TG-DTG-DTA-T-P, Mettler Instrument Corporation, Company Brochure 79) TA 2000 C, Thermoanalyzer for Simultaneous TG-DSC, Mettler Instrument Corporation, Company Brochure 80) G. Cohn, Ed, *Expls&Pyrots* 10, (4), (Apr 1977) 81) L.J. Bailin et al, "Development of Microwave Plasma Detoxification Process for Hazardous Wastes", *EnvironmSci&Tech* 12 (1978), 673 82) D.E. Pennington, T. Man & B. Persons, "Rocket Hazard Summary: Safety Classification Handling Experience and Application to Space Shuttle Payload", NASA Cr 145185 (1977) 83) Table 6 below

Table 6
 Department of Defense Explosives Safety Board (DDESB)
 Proceedings of the Annual Explosives Safety Seminars

Seminar	Year	AD No	Seminar	Year	AD No
1	1959	135 188	11	1969	862 868L Vol I
2	1960	332 709	-	-	861 893L Vol II
3	1961	332 711	12	1970	716 790
4	1962	332 710	13	1971	890 544L
5	1963	346 196	14	1972	758 990
6	1964	456 999	15	1973	775 580 Vol I
7	1965	368 108	-	-	775 660 Vol II
8	1966	801 103	16	1974	A007 557 Vol I
9	1967	824 044	-	-	A007 566 Vol II
10	1968	846 612	17	1976	A036 015 Vol I
			-	-	A036 016 Vol II

"Safety Jelly". A Ger permissible Dynamite contg NG 32.25, collodion cotton 1.25, jelly (glue-dextrin-glycerin) 9.60, rye flour 18.00, AN 22.60, Na nitrate 10.80, and K chloride 5.50%

Ref: Naoúm, NG (1928), 407

"Safety Nitro" Powder. An older American Dynamite contg NG 69.0, Na nitrate 18.0, and wood pulp 13.0%

Ref: Naoúm, NG (1928), 284

Safety Pin. A device designed to fit the mechanism of a fuze and to remain with it thruout transportation. Presence of the safety device prevents arming or functioning of the fuze, and

the device is intended to be removed by the user just prior to employment. A *safety wire* is a wire set into the body of a fuze to lock all movable parts into safe positions so that the fuze will not be set off accidentally. It is pulled out just before firing. In some cases it is called "safety pin"

Ref: Anon, OrdnTechTerm (1962), 264-L

Sagger. NATO code-name for a Russ anti-tank missile, also known by the US alphanumeric designation **AT-3**, which is currently extensively deployed in Europe and elsewhere. In its man-portable version, the missile is carried into action in a Fiberglas case in which the warhead is separated from the motor. The lid of the case forms a base for launching the missile which has a launch rail on the underside of the motor section. The two parts are taken out of the case and the front legs of the rail on the motor section are slotted into the lid so that there is a small angle of elevation. This is done to ensure that the missile enters the operator's field of view when launched. The warhead (HEAT, piezo-electric fuze) is then clipped to the body. The missile is aligned on the target or the center of the primary arc, and the launcher is strapped to stakes driven into the ground. The leads from four missiles are connected to a control box which incorporates a periscopic sight and a control stick

If the target is less than 1000m away, the operator does not use the sight but guides the missile to the target by eye. If the target is further away (missile range 500–3000m), he sights the missile to a line above the target and then controls it thru the 10X magnification periscopic sight

The method of guidance is line of sight command, and the corrections are transmitted thru a multi-core cable fed out from the missile. The missile has two solid proplnt motors, the front annular motor being a booster. The rear motor controls the missile thru two jetavator nozzles at the rear which swivel according to the commands transmitted thru the wire. Four plastic fins provide for roll stabilization

The HEAT warhead can penetrate 400mm+ of tank armor

Ref: D.A.R. Archer, Ed, "Jane's Infantry Weapons—1977", 3rd Ed, Franklin Watts, NY (1977), 610–11

Sainfoin Nitrate (Nitrated Sainfoin). An expl prepd in Fr by the nitration of dry sainfoin (a perennial plant, *Onobrychis Sativa*, cultivated in Europe for forage). By combining nitrosainfoin with rosin, ozocerite, collodion cotton, glycerin, and charcoal or soot, a mixt suitable for use as a proplnt was obtained

Ref: Daniel (1902), 570 & 773

Saint Helen's Powder (Brit). An Ammonal (see Vol 1, A287-L to A293-L) which passed the Woolwich test. It contained AN 92–95, Al 2–3, TNT 3–5, and moisture 0–1%

Ref: Marshall 1 (1917), 393

Saint Marc Powder (Brit). A smokeless powder, similar to that of Vieille (qv), which made its appearance in Engl and Fr in 1892. It was in the form of semi-transparent tablets of greenish-blue color, measuring 10 x 4mm

Ref: Daniel (1902), 699

Salicylaldehyde and Derivatives. See under "Hydroxybenzaldehyde and Derivatives" in Vol 7, H233-R

Salicylic Acid and Derivatives. See under "Hydroxybenzoic Acid and Derivatives" in Vol 7, H236-L to H238-L. Addns to this entry are:

Under "... *Ortho or Salicylic Acid* ...", the USA military specification (Ref) contains the following chemical requirements:

Table 1
Salicylic Acid Specification Requirements

Requirement	Percent by Weight	Method of Test
Assay (as HO.C ₆ H ₄ .CO ₂ H)	99.5%, min	a
Maximum impurities		
Solubility in alcohol	To pass test	b
Residue on ignition	0.020	c
Chloride (Cl)	0.002	d
Sulfate (SO ₄)	0.005	e
Heavy Metals (as Pb)	0.0005	f
Iron (Fe)	0.0003	g
Substances darkened by sulfuric acid	To pass test	h

- a – By titration with 0.1 normal NaOH to a phenolphthalein end pt
 b – By obtg a clear soln
 c – Gravimetrically as percent of sample
 d – By comparison to a turbidimetric std. Turbidity of the sample must be less than that of the std
 e – By comparison to a turbidimetric std. Turbidity of the sample must be less than that of the std
 f – By comparison with a turbidimetric std. The sulfide turbidity of the sample must be less than the std
 g – By comparison of the red color of a ferric ammonium sulfate soln with that of a K ferric thiocyanate soln obtd from the acidified residue of an ignited salicylic acid sample. The red color of the sample soln must be lighter than that of the std soln
 h – By soln of a salicylic acid sample in 96% sulfuric acid. The color of this soln must be lighter than pale yel

Ref: Anon, "Salicylic Acid, Reagent", MIL-S-11320A (Cml C) (June 1959)

Presented next are two metallic salts of salicylic acid which were developed for use as burning rate modifiers in double-base rocket proplnts. For more information on metallic salts such as these, refer to Vol 8 under "Propellants, Solid; VI Chemical Characteristics and Performance", P430

Basic Copper Salicylate (Monobasic Copper Salicylate). According to Satriana (Ref 2), X-ray spectroscopic studies indicate the following possible structural formulas:

- 1) C₆H₄(OH).C(O).O.Cu.O.(O)C.(OH) C₆H₄.Cu(OH)₂;
- 2) C₆H₄(CO₂):Cu.H₂O;
- 3) C₆H₄(OH).C(O).O.Cu.OH; mw (?); light to dark grn crysts; mp, three TGA peaks are found: 145°, 175° and 275° (decompn). V sol in w,

sol in hot concd acetic ac; v sl sol in methanol; insol in ethanol, ether and cold acetic ac. Prepn is by reacting basic Cu carbonate with salicylic acid in a 1 to 2.2 molar ratio. The reaction media is an aq soln of ethanol (33%). The reaction is accomplished in five hrs at 50–60° with stirring. The pptd prod is filtered off, washed with a 33% ethanol/w soln and then dried at 50°. The yield is 94.18% based on the amt of basic Cu carbonate used in the reaction. The salt has been used as a ballistic modifier in proplnts on a developmental basis similar to dibasic Pb-β-resorcylate

Refs: 1) Beil 10, 59, (25) & [33] 2) D.R. Satriana, "Preparation of Analytically Pure Monobasic Copper Salicylate", PATR 2023 (1971)

Addnl Refs (Limited Distribution): A) R.M. Abbott & N.M. Lizst, "A Broad Spectrum Polarographic Method for the Estimation of

Metallic Components of Propellants and Related Items", PATR 1788 (1967) B) R.G. Wetton, "Technical Status Report Rocket Propellants Program Propellants Laboratory", PATM 1964 (1970) C) R.M. Abbott & N.S. Gelber, "Analysis of Lead and Copper Salts of Hydroxy-Substituted Benzoic Acids", PATR 4376 (1972)

Lead Salicylate. $\text{Pb}[\text{O}(\text{O})\text{C}_6\text{H}_4(\text{OH})_2 \cdot \text{H}_2\text{O}$; mw 483.46; soft creamy white crystals; d 2.3g/cc; RI 1.78. Sol in ethanol, hot w and glycols and glycol ethers such as diethylene glycol mono-phenylether, diethylene glycol mono-3-heptylether and diethylene glycol mono-2-ethylhexylether (Refs 4 & 7). Prepn is by reacting salicylic acid with aq Pb acetate (Ref 6). The compd is combustible. It is used primarily as a burning rate modifier in double-base rocket proplnts. Addn of about 2.5% of Pb salicylate to many formulations produces a mesa or plateau burning rate effect which results in a pressure plateau (Refs 2 & 3)

The requirements of the US armed forces are covered by a military specification (Ref 1a) which contains the following criteria: (1) form — soft crystals; (2) color — white; (3) Pb as Pb sulfate, 43.0% min; (4) salicylate by Na thio-sulfate titration of iodine liberated in a reaction involving an excess of Br not used to initially brominate the salicylic acid sample, 55.4% min; (5) volatile matter, loss in wt, 0.25% max; (6) granulation — 99.90% min shall pass thru US standard sieve No 325 (45 microns); and (7) workmanship — no foreign or extraneous material shall be present

Ref 7 considers Pb Salicylate "... probably toxic ..."

Refs: 1) Beil 10, [34] 1a) Anon, "Lead Salicylate", MIL-L-13788 (1954) 2) J.E. Ranier & J.M. Swotinsky, "Development of a Medium Burning Rate (0.45m/sec) Mesa-Type Rocket Propellant — T-19 Propellant", PATR 1992 (1954) 3) B.J. Kondrot, "Investigation of the Use of Phthalocyanines as Ballistic Modifiers in Mesa Type Double-Base Propellant Formulations", PATR 2040 (1954) 4) F.S. Holahan et al, "Research on Rocket Propellant-Cast Double Base-Non Explosive Plasticizers which are Solvents for Lead Salicylate", PATR

2144 (1955) 5) A.R. Lusardi et al, "Description of Procedure Used for Manufacture of Engineering Test/Service Test Quantities of XM33 Propellant Grains for the 105mm XM548 Rocket Assisted Projectile", PATR 3723 (1968) 6) Kirk & Othmer 17 (1968) 7) CondChem-Dict (1977), 507

Addnl Refs (Limited Distribution): A) A.T. Camp, "Research, Development and Large-Scale Application of Temperature-Independent Double-Base Propellants: A Brief Survey and History", IHSP 68-14 (1968) B) R.M. Abbott & N.S. Gelber, "Analysis of Lead and Copper Salts of Hydroxy-Substituted Benzoic Acids", PATR 4376 (1972)

Salicylic Acid-Diazoniumhydroxide-(5).

$\text{HO}(\text{N}::\text{N})\text{N}_2\text{C}_6\text{H}_3(\text{OH})\text{C}(\text{O})\text{OH}$; mw 182.14; N 15.38%; OB to CO_2 -114.20%; nearly colorl ndles, crystals with 1 H_2O are prisms; mp 145° (decompn), explds at 155° . Prepn is by reacting 5-Diazo Salicylic Acid (see below) with hydrogen chloride in ethanol

Ref: Beil 16, 553

5-Diazo-Salicylic Acid. $(\text{N}_2::)\text{C}_6\text{H}_3(\text{O})\text{C}(\text{O})\text{OH}$; mw 164.13; N 17.07%; OB to CO_2 -126.73%; yel powder; mp, explds at 155° . V sol in hot w and Na carbonate soln; v sl sol in organic solvents. Prepn is by reacting nitric acid with an ethanolic soln of 5-amino-salicylic hydrochloride. The yield is then hydrolyzed with Na carbonate soln, decolorized with charcoal and recrystd from acetic acid

Ref: Beil 16, 553

Following are two addnl salts of 3,5-dinitro-salicylic acid, erroneously called "... 3,5-Dinitro-4-Hydroxybenzoic Acid ..." in Vol 7, H237-R:

Barium 3,5-Dinitrosalicylate (3,5-Dinitro-2-Hydroxybenzoic Acid, Barium Salt).

$\text{BaC}_7\text{H}_2\text{O}_7\text{N}_2 \cdot 3\text{H}_2\text{O}$; mw 417.50; N 6.71%; OB to CO_2 -38.32%; yel ndles; mp 300° (ignites). V sol in hot w. Prepn is by reacting an aq soln of Ba carbonate with 3,5-dinitro salicylic acid

The Ba salt has an impact sensy of 20cm

(complete detonation) and sliding-rod test results of 5 detonations/5 trials at angles of 45° and 75° (Ref 2)

Dipotassium 3,5-Dinitrosalicylate (3,5-Dinitro-2-Hydroxybenzoic Acid, Dipotassium Salt).

$K_2C_7H_2O_7N_2 \cdot H_2O$; mw 322.33; N 8.69%; OB to CO_2 -39.71%; dark red ndles; mp 280° (ignites). Sol in hot w and hot aq ethanol. Prepn is by reacting 2 moles of concd aq KOH with one mole of 3,5-dinitrosalicylic acid

The Dipotassium salt has an impact sensy of 40cm (complete detonation) and sliding-rod test results of no detonations/all trials at angles of 45° and 75° (Ref 2)

Refs: 1) Beil 10, 122 & {207} 2) M.I. Fauth, "Salts of 3-Nitro-, 5-Nitro- and 3,5-Dinitrosalicylic Acids", NPF MR 137 (1957)

Two other salicylates of interest can be found in Vol 6 under "Ethylsalicylate and Derivatives"; **Trinitroethyl Salicylate** (E329-R) and **Trinitroethyl-3,5-dinitro-Salicylate** (E330-L)

Salite. An expl patented by Bergenstrom in 1878 contg about 65% NG and 35% urea nitrate
Ref: Daniel (1902), 699

Salted Weapon. A nuclear weapon which has, in addition to its normal components, certain elements or isotopes which capture neutrons at the time of the expln and produce radioactive products over and above the usual radioactive weapon debris

Ref: J. Quick, "Dictionary of Weapons and Military Terms", McGraw-Hill, NY (1973), 383

Salvage of Ammunition. The term "salvage", as used in a military sense, includes those operations necessary to disassemble or break-down ammunition and its components so as to recover from them all materials or components which are or may be made serviceable, or which have a money value as scrap

See also under "Renovation of Ammunition" and "Reclamation of Energetic Material Components from Ordnance Ammunition" in this Vol

Salvo, Project. A US project originated in 1952, and an important factor in the appreciation of the current search for a more effective rifle cartridge. Approaching the basic problem of how, when, where and why infantry suffered casualties, an exhaustive analysis of a large number of casualty reports was conducted. This study influenced thought both on weapon and ammo design and on infantry tactics. The random nature of hits on human targets that was shown by the analysis led to the conclusion that hits were as often as not the result of unaimed fire. It was also widely accepted that, for each bullet hitting a target, considerable expenditure of ammo had taken place. All this cast doubts upon the traditional belief in the need for a high precision rifle, since the precision inherent in most military rifles was, apparently, rarely used effectively, and certainly not beyond a few hundred meters or so. The investigation concluded that an infantry weapon capable of dispersing its shots would neutralize human error, and significantly increase the hit ratio out to normal max infantry fighting ranges of 300 to 400 meters. This concept was contrary to the then current program for a high velocity, long range, selective fire, self-loading rifle, using a full power large caliber conventional cartridge. Nevertheless, the Salvo project went ahead, the project specification requiring that a) for each trigger pull a salvo of small, high velocity projectiles be fired; b) the projectiles describe a circular pattern on the target; c) all the projectiles be lethal at 400 meters; and d) the salvo have enough projectiles to secure at least one hit on a man-sized target at ranges up to 400 meters

The Salvo program covered cartridges up to .30 caliber, fired from weapons designed to give dispersed shots, fired in rapid succession or simultaneously. Dispersion was achieved in a variety of ways: by multi-barrelled weapons, by single barrelled weapons with muzzle adaptors, and by cartridges firing more than one projectile

Included in the Salvo project were single flechette and multi-flechette cartridges, as well as flechette "shot" cartridges

In 1962, the Salvo project was halted and in the same year was superseded by Salvo Squeeze-bore (see below)

Ref: D.H.R. Archer, Ed, "Jane's Infantry Weapons-1977", Franklin Watts, NY (1977), 370

Salvo Squeezebore (SSB). See "Salvo, Project" above

SSB bullets were cone shaped, hollow projectiles, in tandem, head-to-tail, usually enclosed in plastic, and held in the case neck. These cartridges were fired thru tapered barrels, the tapering being achieved in different ways. The barrel could be of normal type with the front portion merging into a smooth bored tapered section. A refinement on this was to have a further cylindrical rifled portion forward of the tapered portion. The third method, and the one bestowing most flexibility on the rifle, was that in which the tapered portion was a removable extension that could be screwed onto any weapon, thereby giving SSB capability to that weapon

The reducing caliber, or tapered barrel, caused the cone shaped, hollow metal bullets to be swaged into a longer form, in the reduced caliber, the cross-sectional area of the bullet being reduced to about one quarter of its original value in the process. It was found that only a little of the velocity of the bullets was lost in the swaging process, but it was found that the front bullets travelled faster than those following, a fact that could be compensated for by increasing the wt of the front bullet

Between 2 and 8 bullets per cartridge were successfully fired under trial conditions, although in fully developed ammo the number usually ranged between 3 and 5. Depending on the requirement, the SSB ammo offered a fair amount of choice. A greater number of bullets of light wt gave a shorter lethal range but a greater hit probability. Fewer but heavier bullets gave increased range, while for very long range a single squeezebore bullet could be used

Initial faults to do with excessive bullet dispersion and the fragility of the forward bullet in automatic feeding weapons were overcome by 1965, as was the problem of excess wear on the tapered portion of the barrel

Salvo Squeezebore was first publicly tested in 1962, when .50 to .30 caliber (.50 caliber bullets swaged in firing down to .30 caliber) and .50 to .15 caliber cartridges were successfully fired. Over the next five years a number of other SSB cartridges were developed. In 1967, the US Navy, who were responsible for riverline operations in support of the Army in Vietnam, invested in .50 to .30 cal ammo and used SSB

machine guns in such operations. The SSB ammo gave .50 caliber machine guns, with a normal rate of fire of 600 rounds/min, a capability of 3000 shots/min

Representative SSB cartridges had the following make-up: a) .50 to .30 caliber cartridge, with 5 projectiles each weighing 140 grains (9 gms); the velocity of the front bullet was 930 m/sec; b) .30 to .15 caliber cartridge with 3 bullets each weighing 20 grains (1.3 gms); the velocity of the front bullet was 1220m/sec; and c) .45 to .38 caliber pistol (Colt) with 3 bullets each weighing 80 grains (5.2 gms)

Salvo Squeezebore was overshadowed by the SPIW Flechette (qv) program, and was eventually replaced by it

Ref: D.H.R. Archer, Ed, "Jane's Infantry Weapons-1977", Franklin Watts, NY (1977), 370-71

SAL-X Powder Mixtures. Mixts of sulfur and aluminum. Work on these mixts was undertaken during WWII during the development of the M-69 Incendiary Bomb. One lb of a mixt contg 75% Al, compressed at 10000psi with a Tetryl burster, was stated to yield an expl pressure some 30% greater than an equal wt of TNT. The concn of SO₂ resulting from the functioning of some SAL-X mixts resulted in marked antipersonnel effects

Ref: A.E. Gaul & L. Finkelstein, "History of R&D in the CWS in WWII", Vol 18, Pt 3 (Jan 1952), 103

Samsonites (Brit). Permitted expls used prior to and subsequent to WWI: NG 57-60, collodion cotton 3-4, K nitrate 17-19, woodmeal 5-7, amm oxalate 12.5-14.5, and moisture 0 to 1.5%. The compn used in 1928 (Samsonite No 3) contained NG 51.5, collodion cotton 3, amido compd 0.3, Na nitrate 10, Na chloride 10, and borax 25.2%. Its limit charge was 24 oz; BalPend swing 2.42"

Refs: 1) Marshall 1 (1917), 374 2) Ibid 3 (1932), 109

"Sand Bullets". In order to eliminate damage to heavy equipment dropped by parachute, a num-

ber of deceleration devices were developed in the USA during WWII which were capable of bringing the load to an almost complete stop just prior to hitting the ground. This device consisted of a U-shaped tube containing sand filler in each leg and an expl charge in the bent portion. In use, the charge was expld several feet above the ground, the "sand bullets" being fired downward causing a strong recoil upward against the load

Another equally effective device was a so-called "bare charge" unit, in which a small expl charge was placed between the parachute and the load. This was detonated when the load was several feet above the ground, with the resultant shock wave striking the interior surface of the inflated parachute, causing an upward pressure sufficient to markedly slow the descent rate prior to landing

Ref: Anon, ArOrdn 31, No 159 (Nov-Dec 1946), 222

Sand Test. See under "Sand Test or Sand Crushing Test" in Vol 1, XXI to XXII; "Brisance or Shattering Effect" in Vol 2, B265-L to B297-L; "Brisance-Detonation Velocity Relationship" in Vol 2, B297-L to B299-L; and "Brisance Test Methods" in Vol 2, B299-L to B300-R

Sanlaville and Laigant Powder. An older chlorate expl contg K chlorate 28.8, K or Na nitrate 16.4, K or Na bisulfate 20.7, charcoal 28.8 and glycerin 5.3%

See refs under "Chlorate Explosives" in Vol 2, C206-L

Sapojnikoff, Aleksei Vassilievich (1868-1935). Russian scientist and educator, considered to be a pioneer in the chemistry of expl materials. He was born in Siberia, and received his early education with the Corps of Cadets in Omsk and afterwards at the Michael Artillery School and Michael Ordnance Academy in Petrograd. Sapojnikoff was appointed professor of chemistry at the Michael Ordnance Academy in 1899 and held that post up to his arrest by Soviet authorities in 1931, which was followed by exile to Siberia and premature death in 1935

His outstanding researches were on the

chemistry of expls, and dated from the beginning of the present century up to WWI. Sapojnikoff was not satisfied with the empirical knowledge of the nitration of cellulose and thought that a study of the physico-chemical conditions in the mixed acids used for nitration would throw some light on the question. He therefore measured the vapor pressures of mixts of sulfuric acid, nitric acid, and w and showed the conditions under which all the w is attached to the sulfuric acid and the nitric acid left free, and also when further addition of sulfuric acid removed the w from the nitric acid, with formation of nitrogen pentoxide. From this work, he went on to study the relation between the nitrating capacity of mixed acids on cellulose and their vapor pressures. Sapojnikoff was considered by many of his contemporaries to be the "father" of the theory of nitration of cellulose

Refs: 1) Anon, Nature (April 25, 1931)
2) W. Macnab, Nature (May 2, 1931), 1-2
3) H. Brunswig, SS 30, 328-32 (1935) (obituary and biography)

SAW. Acronym for the US Squad Automatic Weapon project which ran from 1972 to 1975. It involved the development of weapons and ammo of nominal 6.15mm cal with a view to providing a light automatic weapon capable of engaging targets out to 1000m or so, but not capable of performing the mounted machine gun function of providing sustained fire at significantly greater ranges

More than one basic 6mm ammo case design was developed in the course of SAW trials. Case materials used were brass, Al and steel, and the best known cartridge to evolve was the XM732. This design had a 45mm case length, and a long, high sectional density bullet weighing 106 grains (6.87g) and having a muzzle velocity of 762m/sec

In the automatic weapon competition, a number of units were entered, some originating in the USA and some from FN in Belg and Heckler and Koch in West Ger. Three US entries took part in the trials, which were completed in 1974. They were the Maremont XM233, the Philco-Ford XM234 and an entry from Rodman Laboratory, Rock Island Arsenal. Following the successful completion of the trials, when the contest-

ants were reduced to the US Rodman entry and the FN Minimi, the project was shelved until the conclusion of the 1977–1979 NATO small-arms trials

Ref: D.H.R. Archer, Ed, "Jane's Infantry Weapons—1977", Franklin Watts, NY (1977), 247–49 & 372–73

Saxifragine (Poudre de mine de Wynants). Fr blasting powder of the 1860's contg Ba nitrate 76, charcoal 22, and K nitrate 2%

Ref: Gody (1907), 171

Saxonites. Safety expls manufd in Engl prior to and after WWII by Nobel's Explosive Co, Ltd at Ardeer, Ayrshire. One of its varieties was prepd by mixing 27p of amm oxalate with 73p of the following mixt: NG 58, K nitrate 25.5, NC 3.5, woodflour 6, lime 0.5 and moisture 6.5%. This expl was placed on the "special list" which allowed its use in the most dangerous coal mines. Requirements for expls on this list were more rigorous than for "permitted explosives"

Saxonites were packaged in parchment paper cartridges and initiated by a detonator not weaker than a No 6 (contg 1 g of a compn consisting of MF 80 and K chlorate 20%)

Refs: 1) Daniel (1902), 701 2) Marshall 1 (1917), 374 3) Naoúm, NG (1928), 409 4) Urbański 3 (1967), 404

Sayers' Explosives. A series of blasting expls patented by J. Sayers et al in 1911. Their compns are given below:

Formulation No	<u>1</u>	<u>2</u>	<u>3</u>	<u>4</u>	<u>5</u>
NG, %	23.8	18.9	17.2	16.0	15.8
NC, %	1.6	1.3	1.3	1.2	—
K chlorate, %	—	—	60.3	—	—
K perchlorate, %	52.4	58.7	—	—	—
Amm nitrate, %	—	—	—	70.0	—
K nitrate, %	—	—	—	—	41.0
MNN, %	1.1	0.9	1.2	1.1	1.1
DNT, %	3.3	2.6	3.6	3.3	3.8
TNT, %	5.8	4.6	6.4	5.9	5.8
Woodmeal, %	12.0	9.5	10.0	2.5	32.0
Mg carbonate, %	—	0.5	—	—	0.5
Graphite, %	—	3.0	—	—	—

Ref: J. Sayers, W.A. Wilson & J. Thorburn, USP's 995187, 995373, 995344, 995375 & 995376 (1911) & CA 5, 2724–25 (1911)

Scabbing. Breaking off of fragments from the inside of a wall of hard material resulting from the impact of kinetic energy ammo or the functioning of chemical energy ammo on the outside wall (Ref 1)

A recent example of chemical energy ammo utilizing this principle are so-called **HESH (High Explosive Squash Head)** rounds. In this type of round, a large quantity of plastic HE is carried in a shell. When it strikes armor plate, the HE filling "mushrooms" on the armor face, and a base fuze detonates it. This system does not go thru the plate — the shock wave from the detonation is transmitted thru it. When it reaches the far side it is reflected back, which overstresses the metal on the inside of the plate so that a large "scab", often several feet across, is detached. This whirls around inside the tank at high velocity causing casualties and damage. The thickness of plate attacked by a HESH projectile is proportional to its caliber. To produce a good scab on a modern tank, a caliber of about 120mm is required (Ref 2)

Refs: 1) Anon, OrdTechTerm (1962), 265 & 283 2) C. Chant, Ed, "How Weapons Work", Henry Regnery Co, Chicago (1976), 50

SC Cordite. See under "Cordite SC" in Vol 3, C532-R

Schäffer Powder. Blasting powder patented in Engl in 1863 and 1866 contg K and Na nitrates, sulfur, charcoal and Seignette's salt (K-Na tartrate)

Ref: Daniel (1902), 702

Schatzmann Plastic Safety Explosives. A process was patented in 1909 by Dr P. Schatzmann which covered the manuf of expls formed by dissolving NG in nitro-compds or mixts of aromatic compds (for example, DNT and TNT), the mp of the solvent not exceeding 15°. The mixt was phlegmatized, and collodion cotton and

oxidizing agents incorporated by kneading
Refs: 1) P. Schatzmann, SwissP 48097 (1909)
 2) Colver (1938), 731

Scheelite. Incendiary agent used to some extent during WWI. It consisted of 1 p hexamethylenetetramine and 2p Na peroxide. When ignited with sulfuric acid it reacted very rapidly in the open, generating considerable heat and flames. When confined it explds

Refs: 1) A.M. Prentiss, "Chemicals in War", McGraw Hill, NY (1937) 2) Anon, "Incendiary Weapons", MIT Press, Cambridge, Mass (1975), 89

Schindler Powder. Chlorate expl patented in Engl in 1893 contg K chlorate 60, pulverized anthracite 25, and sugar 15%. See also under "Chlorate Explosives" in Vol 2, C206-L

Ref: Daniel (1902), 703

Schiesswolle 8. See under "Hexamite" in Vol 7, H85-L

Schist Oil. The nitration of schist and similar oils can be conducted with mixed nitric (1-3p) and sulfuric acids (2-3p), using 300-330p of mix per 100p of oil. The temp is kept at about 20° during the addition, after which it is raised to 40-70°

Ref: F. Gehre, BritP 342 (1908) & CA 3, 1593 (1909)

Schlieren Method. See under "Cameras, High-Speed Photographic" in Vol 2, C15-R to C16-L

Schlüsselburgit. A Rus pre-WWI coal mining expl contg NG (gelatinized with collodion cotton) 12, AN 54, glycerin 4, vegetable meal 6, Na chloride 20, and talcum 5%

Ref: Anon, SS 12, 410 (1917)

Schmid, Arnold (1903-1930). Austrian engineer who invented a process for the continuous nitra-

tion of glycerin and other liqs to form liq expls such as NG, NGc, DEGDN, etc (Ref 1). The process involves not only continuous nitration, but also continuous separation and washing of the product. A novel idea introduced by Schmid was a nitrator made of acid-resistant steel fitted for mechanical stirring. His method was further improved on and developed by Joseph Meissner (Ref 2). A distinctive feature of the improved method consists of the extensive use of metering devices and rotameters

See also under "Continuous Methods for Manufacturing Explosives" in Vol 3, C501-R to C504-L

Refs: 1) A. Schmid, SS 22, 169 & 201 (1927)
 2) A. Schmid & J. Meissner, BritPats 284700, 284701 to 299384 (1927) 3) A. Hoenig, SS 25, 403-04 (1930) (obituary) 4) Stettbacher (1948), 60 5) Ibid, Explosivst (1959), 68-71
 6) Urbański 2 (1965), 99-106 (details of Schmid and Schmid-Meissner process)

Schnebelin (or Schnebelite) Powder. See under "Chlorate Explosives" in Vol 2, C206-L

Schnebelin-Boileau Powder. See under "Chlorate Explosives" in Vol 2, C206-L

Schneiderite (Fr). See under "Explosif Sc" in Vol 6, E364-L. Fr mil expls with the designations N2TN, NDTN, NT, NTN and NX are modifications of Schneiderite

Addnl Refs: 1) Urbański 1 (1964), 423
 2) Ibid 3 (1967), 260

Schneider Ordnance. Ordnance originally manufd in the Schneider works in Fr, and used at times in US, Fr, Rus and Jap armies. The Schneider recoil system employed a hydro-pneumatic principle without a floating piston
Ref: Anon, OrdnTechTerm (1962), 266-L

Schönbein, C.F. (1779-1868). Swiss scientist who was the first to prepare NC which was expl (1846). He investigated how various organic and inorganic substances, among them cotton,

sugar, etc, behave when treated with nitric acid in the presence of sulfuric acid. He paid special attention to the properties of the product obtained from cotton, which he named *guncotton* in order to emphasize the possibility of using it as gunpowder. Schönbein's important contribution was that he indicated the practicability of the large-scale application of NC as an expl
 Refs: 1) C.F. Schönbein, USP 4874 (1846); BritP 11407 (1846) (in the name of J. Taylor)
 2) T. Urbański, MAF 13, 827-29 (1934)
 3) Urbański 2 (1965), 214

Schöneweg, M. Patented in Fr the concept of adding oxalic acid and oxalates to gelatinized NC or expl compns, in order to prevent the formation of hot flames as well as to improve their stability (Ref 1)

Schöneweg was also the first to photograph the flames produced at the moment of an expln in order to judge the safety of an expl for use in gaseous mines (Ref 2)
 Refs: 1) M. Schöneweg, FrP 183380 (1887)
 2) Daniel (1902), 704

Schuler Powder. See under "Chlorate Explosives" in Vol 2, C206-L

Schulhof and Quirin. Patented in Fr in 1884 a proplnt prepd by compressing pulped NC into grains followed by coating with collodion
 Ref: Daniel (1902), 706

Schückher. Patented in Fr, Engl and Ger (1889-1890) a series of smokeless powders consisting of Nitrostarch (called xyloidine), mineral salts (such as K nitrate or chlorate), picrates, charcoal and organic substances. A typical compn contained Nitrostarch 50, K nitrate 40, and benz 10%, the latter ingredient being evapd after blending

Schückher also patented (1890) a method for the prepn of Nitrostarch which consisted of dissolving dried and pulverized starch in nitric acid, and pouring the soln into mixed nitric-sulfuric acid. After washing and drying, the Nitrostarch was stabilized by the addition of aniline

See also under "Chlorate Explosives" in Vol 2, C206-L

Ref: Daniel (1902), 704-05

Schultz and Gehre Explosives. G. Schultz and F. Gehre of Munich patented in Engl and the USA (1905-1906) a safety expl based on nitrated solvent naphtha, which consisted chiefly of the trinitro compds of mesitylene and pseudocumol. This was mixed with oxidizers, and in certain cases with finely pulverized Fe or Cu. A typical compn was AN 76, K nitrate 10, nitro compd 10, K perchlorate 2, and resin 2%
 Refs: 1) G. Schultz & F. Gehre, BritP 5687 (1905); USP 894707 (1906) 2) Colver (1938), 686

Schultze's Explosives and Powders. Schultze, an artillery captain in the Ger army, in 1867 patented a series of proplnts based on Nitrolignin (nitrated woodmeal or sawdust). The "smokeless powders" antedated by at least 20 years colloidal smokeless powders developed independently by P. Vieille in Fr and M. Dutton-hoffer. Two examples of Schultze's powders are given by Daniel (Ref, p 707) as follows:

Nitrolignin (insol), %	23.36	32.66
Nitrolignin (sol), %	24.83	27.71
Lignin (unnnitrated), %	13.14	1.63
Ba and K nitrates, %	32.35	27.62
Na nitrate, %	—	2.47
Paraffin, %	3.65	4.20
Moisture, %	2.67	3.71

The Nitrolignin was prepd by mixed nitric-sulfuric acid nitration of woodpulp, followed by washing with hot and cold w, pulping in colanders, and boiling with w until all acid was eliminated. After squeezing out the bulk of the w, the Nitrolignin was blended with the above ingredients and grained by passing thru a sieve. After drying in a current of hot air, the grains were hardened by treatment with volatile solvents in a rotating drum, and the remaining solvent removed by evapn

Schultze, in 1886, also patented expls suitable for use in mines, as well as proplnts, all contg nitrated tars, resins or turpentine. Following are some examples:

	Mining Explosive	Propellants	
		Sporting	Carbine
Nitrated tars, resins or turpentine, %	10	7.3	2.2
Pyroxylin, %	10	42.4	62.4
Ba nitrate, %	—	44.8	23.6
K nitrate, %	70	5.5	9.6
Sulfur, %	10	—	2.2

See also under "Dualines" in Vol 5, D1566-L
Refs: 1) Daniel (1902), D1566-L 2) Urbański
 3 (1967), 528-29, 640

Schwab Powder. An older Austrian rifle proplnt consisting of solid grains (0.75mm OD) of NC coated with graphite. The charge was 2.75g; muzzle velocity 600m/sec with a bullet weighing 15.8g; press 1300 atms
Ref: Daniel (1902), 709

Schwartz, H. In 1894 patented a mining expl consisting of a two compartment metallic cartridge containing separately compressed ammonia and chlorine. By means of a mechanical device, or a small charge of expl, the partition was broken and the two gases combined with expl violence to form ammonium chloride (Ref 1)

Schwartz also patented a Dynamite containing 58 to 70p of NG absorbed on 42 to 30p of a mixt of plaster and sawdust (Ref 1), and a blasting powder consisting of K nitrate 56, Na nitrate 18, sulfur 10, and charcoal 16% (Ref 2)
Refs: 1) Daniel (1902), 709 2) Pepin Le-halleur (1935), 287

"Schwarzer" Explosives. The properties of "Schwarzer" expl mixts, consisting of Nitrobenzene 9.23%, nitric acid 30.77%, and the remainder either Guanidine nitrate or Nitroguanidine were detd. Mixts with Guanidine nitrate had at best low brisance, while those with Nitroguanidine had a brisance index of about 1.1 as compared to 1.0 for TNT. However, these mixts were all strongly acid, attacked brass and iron, were very hygroscopic, appreciably volatile at room temp and very volatile at 100°. Because of these characteristics the mixts were

considered unsuitable for mil use

Ref: H. Aaronson, "Suitability of Schwarzer Explosive for Military Use", PATR 1423 (1944)

SC Propellant. See under "Cordite SC" in Vol 3, C532-R

SD NÉO (Fr). Abbrev for solventless proplnt (sans dissolvant) based on diethyleneglycol-dinitrate

SD Ngl (Fr). Abbrev for solventless proplnt based on NG

SDO (Synthetic Drying Oil). A commercial polymer of acetylene (such as SDO-80) which was evaluated as an incendiary mixt component during WWII. A typical mixt contg 1 p of SDO-80 was mixed with 2p of Na nitrate, and the material was exposed to the air with occasional stirring until it had absorbed sufficient oxygen (about 64% of its wt) to form a sticky brown-colored gel. The gel, when ignited, gave a burn time of brief duration and little incendiary value. It was considered to be about 1/10 as effective as a Mg bomb and 1/5 as effective as a "gum" incendiary mixt of that era. Its performance was comparable to that of thermite
Refs: 1) L.F. Fieser, OSRD 173 (1941)
 2) M.S. Kharash & F.H. Westheimer, "Development of SDO as an Incendiary Material, Particularly as a Hand Incendiary", OSRD 677 (1942)

Sear. a) An item so designed as to retain the firing mechanism of a gun in the cocked position. b) A variety of lockwork in the firing mechanism of a proplnt actuated device which prevents motion of the firing pin until released
Ref: Anon, OrdTechTerm (1962), 266-R

Seaweed. A highly expl material is obtained by mixing powdered seaweed 20, Amm nitrate 71.7, NG 8 and collodion cotton 0.3%
Ref: T. Watanabe, JapP 176113 (1948) & CA 45, 4930 (1951)

Sebacic Acid and Derivatives

Sebacic Acid (Decanedioic acid or 1,8-Octanedicarboxylic acid). $\text{HO}(\text{O})\text{C}(\text{CH}_2)_8\text{C}(\text{O})\text{OH}$; mw 202.24; monoc prismatic tablets or flts (from acet and petr eth); mp 134.5° (subl); bp 294.5° ; d 1.207g/cc at $20/4^\circ$; RI 1.422 at 134° . V sol in ethanol, esters and ketones; sol in w; v sl sol in eth. CA Registry No [111-20-6]. Prepn is by heating castor oil with NaOH and passing the Na sebacate soln produced thru a sorbent comprised of carbonized CaSiO_3 or Ca-Mg hydrosilicate (Refs 1, 6 & 7)

Sebacic acid is used as part of the fuel matrix in polyamide based solid propnlts (Ref 3) and polyurethane-Amm perchlorate solid propnlts (Refs 3a, 4 & 5)

The lead salt, *Lead Sebacate*; $\text{PbC}_{10}\text{H}_{16}\text{O}_4$; mw 407.42; an amorph ppt insol in cold w and sl sol in hot w, is recommended for use in pyrot white smoke generating formulations (Ref 2) Refs: 1) Beil 2, 718, (293), [608], [1803] & (2078) 2) J. DeMent, "Halogen Smoke Compositions", USP 2995526 (1961), 12 & CA 55, 25100 (1961) 3) R.D. Thomas et al, "Polyamide-Based Solid Propellants", USP 3162559 (1964) & CA 62, 7579 (1965) 3a) H.R. Lubwitz et al, "Polyurethane Elastomers", USP 3370996 (1968) & CA 68, 80090 (1968) 4) D.L. Granatstein & W.H. Leverne, "Nonreinforcing Filler-Elastomer System. I. Experiments Based on Model Systems", JAppl PolymSci 1974, 18 (1), 1-20 & CA 80, 109562 (1974) 5) A.J. Hammond & H.R. Lobowitz, "Castable Polyurethane Composite Propellants", USP 3791892 (1974) & CA 81 79920 (1974) 6) Merck (1976), 1090 (No 8167) 7) A.A. Kruglikov et al, "Sebacic Acid", USSRP 335933 (1976) & CA 84, 121178 (1976)

Addnl Refs (Limited Distribution): 1) R.D. Shoultz, "Synthesis and Evaluation of N-F Monomers and Plasticizers", Rohm & Haas Co RATR S-164, Huntsville, Contract DAAH 01-68-C-0632 (1968) 2) B.D. Lehman, "Investigation of Compositions to Improve Low Temperature Mechanical Properties of Mortar Increment Containers", PATM 2072 (1973)

Sebacic Acid Diazide. $\text{N}_3\text{CO}[\text{CH}_2]_8\text{CO.N}_3$; mw 252.32; N 33.31%; OB to CO_2 -164.87%; white floc mass; mp $33-34^\circ$. V sol in eth; sol in ethanol; insol in w. Prepn is by reacting

sebacic acid dihydrazide hydrochloride with a cold aq soln of Na nitrite. The diazide decomps on standing. It puffs off weakly when heated Ref: Beil 2, 720

Sebacic Acid Esters

Dibutylsebacate (DBS). See under this title in Vol 5, D1199-R to D1200-L and the following *Addnl Refs*: 1) A.C. Scurlock, "Thixotropic Propellants", USP 3095334 & CA 59, 7311 (1963) 2) R.Hauser & W.F. Rumpel, "Reaction of Organic Materials with Liquid Oxygen", AdvanCryogEngrg 8, 242-50 (1962) & CA 59, 12584 (1963) 3) C.L. Adams, "No Set - A Monopropellant: Preliminary Evaluation", NAVOR IHMR 70-127 (1970) 4) S. Krishnan & T.K. Bose, "Theoretical Performance of Poly (Vinyl Chloride) Plastisol Propellants, Comparative Study", JSpacecRockets 1975, 12 (3), 187-89 & CA 84, 33343 (1976)

Dimethyl Sebacate (DMeSeb). See in Vol 5, D1372-L & R, under this title

Diocetyl Sebacate. See under the title of "Di(2-ethylhexyl) sebacate or Diocetyl Sebacate (DOS)" in Vol 5, D1237-L, and under the title of "Diocetyl Sebacate (DOS)" also in Vol 5, D1402-L to D1403-L. Also, the following *Addnl Refs*: 1) C.J. Barr & H.R. Weisbrod, "Solid-Propellant Fuel Binder", USP 3138502 (1964) & CA 61, 10527 (1965) 2) S. Krishnan & T.K. Bose, JSpacecRockets 1975, 12 (3), 187-89 & CA 84, 33343 (1976)

Sebastines (Swed). A series of Dynamites, invented by A. Boechman of Stockholm in the 1870's, utilizing porous charcoal capable of absorbing up to ten times its wt of NG. A typical formulation contained NG 68, porous charcoal 20, and saltpeter 12%. A so-called *Nysebastine* (New Sebastine) contained NG 45, porous charcoal 30, and saltpeter 25%. Another variation was obtained by mixing 50p of NG with 50p of an absorbent consisting of porous charcoal, NC, Pb peroxide, Na bicarbonate, and dextrin or paraffin Refs: 1) Daniel (1902), 709 2) Gody (1907), 357

Sébert Chronograph. See under Ref 10 in Vol 3, C317-L under "Chronographs"

Sebomite. See under "Chlorate Explosives" in Vol 2, C206-L

Second Problem of Ballistics. Same as gyroscopic movement of projectiles. See under this title in Vol 6, G197-R

Secondary Blasting. In quarrying operations it is invariably necessary to blast rock chunks and boulders to facilitate shovel operations and to break the oversize material down sufficiently to feed into a crusher. This operation is known as *secondary blasting*. Other miscellaneous blasting in a quarry are usually placed in this same category, such as *toe shooting* and *seam shooting*, regardless of whether such shots are fired separately or with the primary blast. Toe shooting involves the use of small diameter holes for removing ledge or high bottom remaining after the main shot is cleaned up. Seam shooting consists of taking down loose or overhanging chunks remaining in a dangerous position up in the quarry face

Secondary blasting may be done either by *blockholing* or *mud-capping*. With the blockholing method a small hole is drilled in a chunk, usually with a hand held air hammer, and is loaded with just enough Dynamite to give the desired fragmentation. In mud-capping, the charge is set in a depression on the boulder and covered with a thick plaster of wet clay to confine it

Refs: 1) Blaster's Hndbk (1969), 347-50
2) C.E. Gregory, "Explosives for North American Engineers", Trans Tech Publication, Cleveland (1973), 263

Secondary Ethers of Polyhydric Alcohols.

Compds such as the secondary butyl eth of glycidol, bp 52° at 14mm; α,α' -disecundary-butyl dieth of glycerol, bp 115° at 14mm; and the secondary amyl eth of glycidol, bp 74° at 16mm, are solvents for NC. In a patd procedure for the manuf of these secondary ethers,

Evans & Bullard (Ref) proposed that these solvents be used as "... reagents in the manuf of explosives ..."

Ref: T.W. Evans & E.F. Bullard, "Secondary Ethers of Polyhydric Alcohols", USP 2197467 (1940) & CA 34, 5572 (1940)

Secondary High Explosives. A high expl which is relatively insensitive to heat and shock and is usually initiated by a primary high explosive. It requires a relatively long distance and time to build up from a deflagration to detonation, and will not propagate in extremely small diameter columns. Secondary high explosives are used for boosters and bursting charges. For addnl information see under "High Explosives (HE)" in Vol 7, H96

Ref: Anon, OrdnTechTerm (1962), 267-L

Securit. See under "Hexanitrodiethylurea" in Vol 5, D1255-L

Securites. Mining expls patented in 1886 and thereafter by Schöneweg of Ger and manufd in Engl and Ger during the 1890's

The original Securites contained, No 1: K nitrate 75 and DNB (Dinitrobenzene) 25%; and No 2: K nitrate 77.7, DNB 19.4, and amm oxalate 2.9%. Later Securites manufd in Engl contained, No 1: K nitrate 84.25 and m-DNB 15.75%; and No 2: K nitrate 81.8, m-DNB 15.2 and amm oxalate 5.00%

A Ger plant, Vereinigte Köln-Rottweiler Pulverfabriken, manufd the following expl, which was also called Securite: AN 37, K nitrate 34 and m-DNB 29%. A so-called Compressed Securite contained K and Ba nitrates 18.90, m-DNB 70.45 and NC 10.65%

Other varieties of Securites were "Denaby Powders" (see Vol 3, D63-L) and "Flameless Securites" (see Vol 6, F50-L)

Ref: Daniel (1902), 710-12

Sedorolite Primary Mixture. A chlorate based expl based on Sb sulfide and sulfur. See refs under "Chlorate Explosives" in Vol 2, C206-R

Seismic Prospecting. Seismic prospecting depends upon the fact that the earth has been segregated by geological processes into layers of varying density and elastic behavior. The purpose of seismic prospecting is to detect irregularities in the layering, such as faults and folds, which may serve as reservoirs for the accumulation of oil and gas. A sudden shock, such as that caused by an expln, sends out seismic energy in all directions. This energy is divided when it reaches the boundaries of geological formations of different acoustic impedances (the density multiplied by the sound velocity). Some of the energy returns to the surface, where it is detected by sensitive instruments. When these instruments are placed near the source, so as to record the energy traveling in an essentially vertical path, the technique is known as the *reflection method*. When the instruments are extended over large distances from the source, as compared to the depths of interest, the technique is known as the *refraction method*. In this case, the seismic energy is propagated over an essentially horizontal path in a high velocity material overlain by lower velocity materials

The vibrations returning to the surface are picked up by extremely sensitive electro-mechanical devices called geophones. These instruments convert the ground motion into electricity, which is amplified and recorded by an oscillograph and a magnetic tape recorder. The oscillogram permits an immediate inspection to determine if the shot was properly recorded. The magnetic tape record is subsequently analyzed at a data processing center where geological maps are prepared (Ref 1, pp 351-52)

In order to initiate these shock waves, special purpose expls have been developed to provide a high degree of reliability, high strength, and excellent water-resistance. To aid in charging deep holes, seismic expls can be provided with cardboard tubes or threaded cans which can be coupled together to form a continuous charge (Ref 1, pp 358-66; Ref 2, pp 48, 52, 64, 65 & 208, and Vol 5, D1607)

Refs: 1) Blasters' Hndbk (1969) 2) C.E. Gregory, "Explosives for North American Engineers", Trans Tech Publications, Cleveland (1973)

Selection of Commercial Explosives and Blasting Agents [From R.A. Dick, "Factors in Selecting and Applying Commercial Explosives and Blasting Agents", USBurMines IC8405 (1968)]

Despite the abundance of available information on blasting techniques, the consumer still finds it difficult to evaluate commercial expls on the basis of the literature. Most of it is filled with information which is of no immediate use to the man in the field such as the drilling and blasting foreman. Although Blasters' Handbooks (such as that of the DuPont Co) and data sheets published by explosives manufacturers are useful with products manufd by a particular company, they cannot apply to other manufacturers of expls (about 20 of them in the USA) because most of the expls are marketed by trade-name, without including their compns. Another difficulty consists of a lack of uniform standards for measuring and describing expl properties and the use of ill-defined properties, such as "strength", which can be either "weight strength" or "cartridge strength"

The ref seeks to acquaint the reader with the great variety of commercial expls and blasting agents available, their advantages and disadvantages, and their general areas of application

The following expl compns used in blasting operations are listed in the ref giving their compn, strength (weight and cartridge), detonation velocity, density, water resistance and fume class. For some, detonation pressure is also given

Since these expls are described elsewhere in the Encycl, they are listed below without detailed descriptions:

1) **Straight Nitroglycerin Dynamites** (Ref, pp 12-13), with weight and cartridge strengths of 20 to 60%, d 1.3 to 1.4g/cc, and deton velocities of 9000 to 19000 fps. They are described in Vol 5 of the Encycl under "Dynamite". Because of their poor fume qualities, they are unsuitable for use in poorly ventilated spaces. The 60% variety is sometimes packaged in special heavy-duty cartridges for use in under-water work. The 50% variety, known as "Ditching Dynamite" because of its use in ditch digging, is mentioned in Vol 1, A113-R. Its high sensitivity to detona-

tion is particularly advantageous in ditching operations, where sympathetic detonation eliminates the need to use a cap or detonating fuze with each individual charge, if the charges are spaced closely enough

Being rather expensive, Straight Nitroglycerin Dynamites have gradually been replaced by "Ammonia Dynamites", described in Vol 5 under "Dynamite" and in Vol 1, A355 to A356

2) **High Density Ammonia Dynamites**, commonly known as **Extra Dynamites**, with weight strengths of 20 to 60%, cartridge strengths of 15 to 52%, d 1.3g/cc, and deton velocities of 8000 to 12500 fps. They are described in Vol 1, A355 and Vol 5 under "Dynamites". They can be used for quarrying (where the rock is not extremely hard and water conditions are not severe), stripping, and in well-ventilated underground mines. Another common use is as an agricultural expl for blasting stumps and breaking boulders (Ref, p 14)

3) **Low Density Ammonia Dynamites** are subdivided into a low velocity (6300 to 8100 fps) and a high velocity (8300 to 11000 fps) series. Both series have weight strengths of 65%, cartridge strengths of 20 to 50%, and d of 0.8 to 1.2g/cc. Volume for volume, these Dynamites are the lowest cost cartridge expls available. Because of their slow heaving action, the low velocity series is restricted to relatively soft materials such as gypsum, clay, or salt. The cartridges are paraffin-sprayed for waterproofing (Ref, pp 14-15 and Vol 5 under "Dynamite")

4) **Blasting Gelatin**, also known as **Oil Well Explosive**. A formulation contg NG 91.0, NC 7.9, antacid 0.9 and moisture 0.2% is described: weight strength percent 100, cartridge strength percent 90, d 1.3g/cc, and deton velocity 25000-26000 fps. It is especially well adapted for underwater use, or in deep wells where high heads of water are encountered, but it is otherwise seldom used because of its high price (Ref, p 16, and Vol 2, B211-R to B212-L)

5) **Straight Gelatins**. These are dense, plastic-textured expls consisting of NG (or other expl oils) 20.2 to 49.6%, gelatinized with NC, Na nitrate, carbonaceous fuel, antacid, and sometimes sulfur. They are manufd in weight strengths of 20 to 90% with corresponding cartridge strengths of 30 to 80%, and confined deton velocities of 11000 to 23000 fps. Their unconfined velocities are much lower. High velo-

city Straight Gelatins are particularly useful as seismic expls as well as for deep well and underwater work (Ref, pp 16-17 and Vol 5, D1607)

6) **Ammonia Gelatins**, also known as **Special Gelatins** or **Gelatins Extra** are Straight Gelatins with a portion of the NG and Na nitrate replaced by AN. Their weight strengths are 30 to 80%, corresponding to cartridge strengths of 35 to 72%; d 1.3 to 1.6g/cc, and deton velocities of 14000 to 20000 fps. Because of Ammonia Gelatins good fume ratings, they are suitable for underground work (Ref, pp 17-18; in Vol 1, A367-R to A368; in Vol 5, under "Dynamite")

7) **Semigelatins** (Ref, pp 18-19 and in Vol 5 under "Dynamite")

8) **Military Explosives Used in Industrial Operations**: TNT, PETN, RDX, Pentolite, Compositions B, C-3 and C-4 (Ref, pp 22-23)

9) **Permissible Explosives** (Ref, p 26; in Vol 3, C444-R to C459-R; in Vol 5 under "Dynamite")

10) **Liquid Oxygen Explosives (LOX)** (Ref, pp 26-27)

11) **Black Powder** (Ref, p 27 and in Vol 2, B165-R to B179-R)

12) **Blasting Agents or Nitrocarbonitrates** (Ref, pp 19-21; in Vol 2 under "Blasting Explosives", B202-L to B211-R; in Vol 8 under "Nitro-Carbonitrate (NCN) Blasting Agents")

Blasting Agents may be subdivided into *Dry Blasting Agents* and *Slurry Blasting Agents*. Because of their insensitivity, all of them should be detonated by a charge of HE, such as Extra Dynamite, Composition B or Pentolite, which serve as Primer and Booster charges. Although Dry Blasting Agents were patented in Sweden in 1867 and were commercially developed in the USA as a *canned* product in 1935, it was not until the mid-1950's with the development of **AN-FO** (Ammonium Nitrate-Fuel Oil) that their full potential was realized. AN-FO began replacing Dynamites and Gelatins in many applications. Then, in the early 1960's the denser Slurry Blasting Agents were developed and began to make further inroads on Dynamite and Gelatin usage, and also replaced Dry Blasting Agents in many areas. If present trends continue, slurries will eventually dominate the blasting field, with dry agents remaining in use in some softer rock formations. Dynamites and Gelatins will be used mostly in smaller operations

and as primers for Blasting Agents (Ref, pp 19-20)

12a) **Dry Blasting Agents** consist of granular or prilled AN and a carbonaceous fuel. In some formulations powdered aluminum or ferrosilicon are incorporated. The most widely used dry agent, known as **AN-FO**, is a mixture of AN prills and fuel oil. When a properly balanced AN-FO mixture detonates, the following reaction occurs:

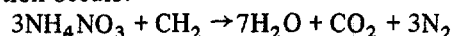

The fuel oil is not precisely CH_2 , but this is sufficiently accurate to characterize the reaction. The right side of the equation contains only the desirable gases of deton, although in practice some CO and NO_2 are always formed. From the left side of the equation one can calculate the percentage of ingredients in an oxygen-balanced AN-FO to be 94.5% AN and 5.5% fuel oil, but in actual practice the proportions are 94 & 6%. The additional fuel oil is added so that a sufficient amount is intimately combined with AN to assure an efficient chemical reaction. As they are not cap sensitive, they must be initiated by a high velocity HE, such as 75% Ammonia Gelatin, Composition B or Pentolite. Inadequate priming imparts a low initial deton velocity to a Blasting Agent and in extreme cases the reaction will die out and cause a misfire. HE boosters are sometimes spaced along a bore-

hole to assure propagation thruout the borehole. In charge diameters of 6 inches or more, Dry Blasting Agents attain, when confined, deton velocities of more than 12000 fps, but in diameters near 1 inch the velocity is reduced to about one-half this value. Advantages of these Dry Blasting Agents are their safety in transportation, storage and handling, as well as their ease of loading and low price. When used in the free-flowing form, they have great advantage over cartridge expls because they completely fill the borehole without leaving voids. This direct coupling to the walls of the borehole assures a more efficient use of expl energy than can be obtd with cartridge expls. In case of wet holes, the water may be pumped out and a plastic liner inserted to serve as a container for the agent. When properly oxygen balanced, the fume qualities of Dry Blasting Agents permit their use underground. At one time they were packaged in metal cans. Although "canned explosives" (as they were known) had unlimited water resistance, they lose the advantages of loading ease and of direct coupling to the walls of boreholes.

Although the sp gr of Dry Blasting Agents varies from 0.5 to greater than 1.0g/cc, the sp gr of AN-FO varies from 0.75 to 0.95g/cc, depending on the density and particle size of the AN. Table 1 shows how the confined deton velocity and the loading density of AN-FO vary with

Table 1
Confined Detonation Velocity and Borehole Loading Density of AN-FO

Borehole Diameter, inches	Confined Velocity, fps	Loading Density, lbs/ft of borehole
1.5	7000 - 9000	0.6 - 0.7
2.0	8500 - 9900	1.1 - 1.3
3.0	10000 - 10800	2.5 - 3.0
4.0	11000 - 11800	4.4 - 5.2
5.0	11500 - 12500	6.9 - 8.2
6.0	12000 - 12800	9.9 - 11.7
7.0	12300 - 13100	13.3 - 15.8
8.0	12500 - 13300	17.6 - 20.8
9.0	12800 - 13500	22.0 - 26.8
10.0	13000 - 13500	27.2 - 32.6
11.0	13200 - 13500	33.0 - 39.4
12.0	13300 - 13500	39.6 - 46.8

borehole diam. Pneumatic loading results in higher deton velocities and higher loading densities, particularly in small (1- to 2-inch) boreholes (Ref, pp 20-21)

12b) **Slurry Blasting Agents** are the most recent development in the Blasting Agent field. They contain AN (part of which is in an aqueous soln) and a non-explosive sensitizer or fuel, such as powdered carbon, sulfur or aluminum. This mixture is thickened and gelled with a gum, such as guar gum, to give the slurry considerable water resistance. These mixtures are not cap sensitive, but they can be made sensitive by incorporating some HE's, such as TNT. In these cases the mixtures must be classified as *Slurry Blasting Explosives* instead of *Slurry Blasting Agents*. Some Blasting Explosives contg TNT are not cap sensitive

Like Dry Blasting Agents, Slurry Blasting Agents require adequate priming with high velocity expls to attain their proper deton velocities, and often require boosters of HE's spaced along the borehole to assure complete deton. The deton velocities of slurries, betw 1000 & 18000 fps, vary with the sensitizers and other ingredients used; also with charge diameter, degree of confinement, and density. The deton vel of a slurry, however, is not as dependent on charge diameter as is that of a Dry Blasting Agent. The sp gr of slurries varies from 1.05 to 1.6g/cc and their consistency ranges from fluid near 100°F to rigid at freezing temps. The use of slurries results in the same advantageous direct borehole coupling as Dry Blasting Agents, as well as a higher deton vel and a higher density. Thus, more energy can be loaded into a given volume of borehole. The consequent marked saving on drilling costs realized by the use of smaller diam boreholes and larger burden and spacing dimensions will often more than offset the higher cost per pound of slurry. The introduction of finely powdered Al as a sensitizer in slurries greatly increases the heat of expln, which, of course, means greater energy release. Aluminized slurries have been used for extremely hard rock with excellent results

The term *slurry boosting* involves the use of a Slurry and a Dry Blasting Agent simultaneously in the same borehole, with the bulk of the charge being dry agent. Charges of slurry loaded at regular intervals in the borehole will increase the

deton pressure of the total charge and improve fragmentation. In another application of "slurry boosting", the slurry is placed in an area where fragmentation is difficult to achieve. A combination of Blasting Agents will often give better overall operational economy than straight Slurry Agent or Dry Agent (Ref, pp 21-22)

Note: See refs on "Dynamites and Their Substitutes" in Vol 5, D1614-L to D1616-R and D1651-L to D1722-R

Properties of Commercial Explosives and Blasting Agents [From R.A. Dick, "Factors in Selecting and Applying Commercial Explosives and Blasting Agents", USBurMines IC8405 (1968)]

Strength. This term is used as a measure of the energy content of an explosive and the work it is capable of doing. In practice, however, the term is inaccurate and misleading, because it is not a true measure of an explosive's ability to perform work. The two strength ratings commonly used commercially are *weight strength* (which compares expls on a wt basis), and *cartridge or bulk strength* (which compares expls on a volume basis). Strengths are commonly expressed as a percentage, with Straight Nitrolycerin Dynamite as the standard. The relation betw the wt and cartridge strengths of a given expl depends on its density. When the sp gr is 1.4g/cc with resulting *cartridge count* (number of 1½x8-inch cartridges in a 50 pound box) near 100, the two strengths are equal. When the sp gr is less than 1.4g/cc (cartridge count greater than 100), the cartridge strength is less than the wt strength; the reverse is true for sp gravities greater than 1.4g/cc. The cartridge count is roughly 140 divided by the sp gr. Neither of the strengths can serve as a good basis on which to choose an explosive (Ref, pp 3-6) (See also Vol 4 of Encycl, under "Detonation (and Explosion) Power, Available Energy and Strength", on pp D476 to D479; and Vol 5, under "Dynamite")

Detonation Velocity is the most important property to consider when rating an explosive. It may be expressed as either confined or as unconfined. Experimental procedures for detn of velocity are described in Vol 4, D629 to D640. The confined velocities for blasting expls vary from 5000 to 25000 fps. For blasting in hard rock, high-velocity expls with inherent high

shattering effects are preferable, whereas in softer rock, low-velocity expls with a *heaving* action may give satisfactory results at a lower cost (Ref, p 6)

Density of an expl can be expressed in terms of sp gr or cartridge count. Sp gr is the ratio of the density of the expl to the density of water under std conditions. Cartridge count, as previously stated, is approx equal to 140 divided by the sp gr. The sp gr of commercial expls ranges from 0.6 to 1.7g/cc with corresponding cartridge counts 232 to 83. High-density expls are required for difficult blasting conditions or where fine fragmentation is needed, whereas low-density expls are useful in the production of lump coal, riprap or other coarse product. For underwater work the density of expls must be higher than 1.0g/cc with a corresponding cartridge count lower than 140, so that they will sink in water (Ref, p 7). Various methods for the determination of density are described in Vol 3, D64-R to D83-R

Detonation Pressure, which is a function of the deton velocity and density of an expl, is a measure of the pressure in the deton wave. Because the amplitude of the stress pulse produced in rock on explosion is related to the deton pressure, the property is an important characteristic of an explosive. The reflection of this stress pulse at a free face is an important mechanism in rock breakage, particularly in hard rock. Although the relationship of deton vel and density to deton pressure is somewhat complex, and depends on the ingredients of an expl, the following approximation is one of several that can be used:

$$P = 4.18 \times 10^{-7} dC^2 / (1 + 0.80d),$$

where: P = Detonation pressure, kbar

(1 kbar = 14504 psi)

d = Specific gravity and

C = Detonation velocity, fps

This empirical formula is not given in Vol 4 of the Encycl, pp D483 to D492

A nomograph in Fig 3, p 8 of the ref (not reproduced here) shows that deton pressure is more dependent on deton vel than on specific gravity. Detonation pressures of commercial expls range from 10 to over 140 kbar and high deton pressure is preferable when blasting hard, dense rock, whereas with softer rock a lower pressure is sufficient (Ref, pp 7-8)

Water Resistance of an expl is a measure of its ability to withstand exposure to water without deteriorating or losing sensitivity to initiation. If a borehole contains water and the time between loading and firing is short, an expl with a water resistance rating of "good" (such as high density Dynamites) can be used. If the exposure is prolonged or if the water is percolating in the borehole, an expl with water resistance of "very good" to "excellent" (such as Gelatin Dynamites) is required. Expls with "poor" water-resistance (such as low-density Dynamites) should only be used in dry boreholes or wet boreholes with a plastic lining. The emission of brown nitrogen oxide fumes observed during blasting often means that the expl has deteriorated from exposure to water, prior to initiation (Ref, p 9)

Fume Class of an expl indicates the nature and quantities of poisonous gases (such as carbon monoxide and nitrogen oxides) formed in addition to carbon dioxide, water vapor and nitrogen always formed on expln of commercial expls. Expl mixts with zero or positive oxygen balance to CO₂ produce much smaller amts of fumes and they are given "better fume ratings". For open work, fumes are not an important factor, but for confined spaces or underground work, expls with "bad fume ratings" should be avoided. The fume rating of a cartridge expl is based on the assumption that the expl will be detonated in its cartridge (Ref, p 9)

Criteria for Selecting an Explosive.

For every given blasting job there is an explosive or blasting agent that will perform the best. To select the most suitable expl or blasting agent, the blaster must define the physical conditions of material to be blasted, such as hardness and density of the rock, geological features, moisture conditions, and available ventilation. He must also define the desired degree of fragmentation and height and displacement of muck-pile. Knowing these factors, he can decide which expl properties are important in his particular situation

In hard, dense rock such as taconite or granite, a high-velocity explosive or blasting agent (such as Gelatin Dynamite or Slurry Blasting Agent) will provide the shattering action needed for maximum fragmentation, although in practice

AN-FO is often used because of its very low cost. A dense expl is also preferable because it permits maximum utilization of each foot of borehole drilled. In hard rock, where drilling costs are high, this economic factor is of particular importance

In softer rock formation, a slower, lower density Blasting Agent, such as AN-FO or a low density Ammonia Dynamite will usually give satisfactory results. An expl contg a high percentage of AN, with its characteristic large volume of gas production and low cost, will often give better muckpile displacement in soft rock than a high-velocity expl. Low-velocity expls are also preferable when a coarse product is desired, as in coal mines

The blaster should avoid the use of expls or of dry blasting agents of poor water resistance when working under wet conditions unless external protection such as a plastic borehole liner is provided. Such liners are recommended primarily for use in vertical holes in open-cut work where the expl or blasting agent is poured into the borehole. When pneumatic loading is used, the plastic increases the hazard of static electricity. More toxic fumes are also generated when plastic liners are used. The Fume class of an expl is an important consideration in underground or tunnel work or wherever ventilation is limited

Other factors such as the cost of loading and firing and the cost of the expl itself, as well as safety considerations, must also be taken into account. The choice of expl affects not only the cost and efficiency of the blasting program but also the economics of the drilling, loading, hauling and crushing programs. This is particularly true of blasting in hard rock where the use of a more expensive expl is required (Ref, pp 9-10)

Ref: R.A. Dick, "Factors in Selecting and Applying Commercial Explosives and Blasting Agents", USBurMines Information Circular **IC8405** (1968) [30 pp and 22 refs; for sale by the Superintendent of Documents, US Govt Printing Office, Washington, DC 20402]

Addnl Ref: R.A. Dick, "The Impact of Blasting Agents and Slurries on Explosives Technology", USBurMines **IC8560** (1972)

Sélénitique (poudre) (Fr). Mixture of NG and plaster of Paris

Ref: Daniel (1902), 712

Selenium. Se; aw 78.96; at no 34; valences 2, 4, 6; six stable isotopes: 74 (0.87%), 76 (9.02%), 77 (7.58%), 78 (23.52%), 80 (49.82%), 82 (9.19%); artificial radioactive isotopes: 70-73, 75, 79, 81, 83-85 and 87; mw (Se_8) 631.68; amor red powdr becoming black on standing and cryst on heating; mp 170-217°; bp 685°; d (cryst form) 4.8g/cc at 20/4°. Sol in concd nitric acid, eth and above mp in common alkalies. The ordn preferred variety of Se is the monoclinic or Se_8 (Ref 4). Se_8 has two modifications, α and β , which are formed together when amor Se is refluxed for 2 hrs in CS_2 (2g/l). The soln is evapd slowly at RT. The two modifications formed can be sepd under a microscope. Amor red Se is prepd by redn of H_2SeO_3 with SO_2 gas. Thus, SO_2 is passed at 15-20° thru strongly acidified (with concd HCl) aq H_2SeO_3 soln. The finely powdered Se ppt is then washed free of Cl^- and SO_4^{2-} ions and dried in a vac desiccator over $CaCl_2$. CA Registry No [7782-49-2]

Selenium is used in delay and igniter compns as a fuel. A typical Hercules Corp compn is Ba peroxide 78% and Se 22% (Ref 2). It has been used successfully in trace amounts in single base (NC) proplnts with DPA as a flash reducing agent (Ref 3) and in pyrot smoke compns as a fuel along with Pb chromate (25%) and Mg (25%). In some smokes as much as 65% Se is used (Refs 4 & 5). Ellern (Ref 6, p 386) gives the following formulations for detonator delays:

Composition No	193	194	195
BaO ₂ , %	80-84	40	70
Se, %	20-16	20	-
Te, %	-	40	30
Rated burning time, sec/inch	3.6-4.0	9.0	4.4

Selenium when added to incendiary formulations, produces an oxide smoke which can cause lung oedema when inhaled (Ref 8). Toxicity, low; dust or fumes causes serious irritation of respiratory tract (Ref 7)

Refs: 1) Gmelin, Syst Nr 10, Teil A, Lfg 1 (1942), 76-80, 95-100, 283-84 and Lfg 2 (1950),

293 pp 2) R.W. Schorf, "Investigation of Hercules Non-gaseous Powder for Use in 21 Second Time Fuze", PATR 598 (1935) 3) C.G. Dunkle, "Study Toward Reducing the Smoke Effects from Flash Eliminating Agents", PATR 705 (1936) 4) D. Hart, "Development of Smoke Composition for the Fuze, Chemical, Mine, AT, Practice, T20", PATR 1596 (1946) 5) J. DeMent, USP 2995526 (1961), 18 & CA 55, 25100 (1961) 6) Ellern, "Pyrotechnics" (1968), 209, 284, 322 & 386 7) Sax (1968), 1085 8) Anon, "Incendiary Weapons", The MIT Press, Cambridge, Mass (1975), 195-96 9) Merck (1976), 1091 (No 8179)

Selenium Nitride. See in Vol 8, N101-R

Self-Destruction (SD). A term descriptive of an event which occurs from fuze or tracer action without outside stimulus, when provided for in the design, by which the fuze or tracer effects projectile or missile destruction, after flight to a range greater than that of the target. Self-destruction (also called "self-destroying") items are also employed in several types of anti-aircraft ammo where impact of unexploded projectiles or missiles would occur in friendly areas Ref: Anon, OrdnTechTerm (1962), 268-L

Semicarbazide and Its Salts

Semicarbazide (Aminourea, Carbamylhydrazine or Hydrazine carboxamide). $\text{NH}_2\cdot\text{NH}\cdot\text{CO}\cdot\text{NH}_2$; mw 75.07; colorl prisms; mp 96° ; d 1.484g/cc at 4° . V sol in w; sol in ethanol. Prepn is by electrolytic redn of nitrourea in sulfuric acid. The base is then obtd by reaction of the semicarbazide sulfate with liq ammonia. CA Registry No [57-56-7]. See also in Vol 2, C45-L, under "Carbazide" for a definition of semicarbazide

Semicarbazide forms salts which are either expl or, as in the case of the hydrochloride, are used in proplnt compns

Semicarbazide Chlorate. $\text{CH}_5\text{ON}_3\cdot\text{HClO}_3$; mw 159.53; N 26.35%; OB to CO_2 -10.03%; mp, explds at RT in the dry state. Prepn as de-

scribed by Datta and Choudhury (Ref 4) consists of treating less than 1 g of semicarbazide hydrochloride (see below) with Ag chlorate. The soln is then allowed to evaporate to dryness at RT in a vac desiccator. The appearance of the first crystals of the solid prod results in a v violent expln. Hence, the chlorate is v unstable in the dry state

Semicarbazide Hydrochloride (Amidourea hydrochloride). $\text{CH}_5\text{ON}_3\cdot\text{HCl}$; mw 111.52; N 37.69%; OB to CO_2 -57.39%; colorl prisms or snow-white crystals; mp 173° , $175-77^\circ$ (sep values, decompn). V sol in w; sol in dil ethanol; insol in absol ethanol and eth. Prepn is by electrolytic redn of nitrourea with cathodes of Cu, Ni, Pb and Hg in hydrochloric acid soln (Refs 1 & 7). CA Registry No [563-41-7]. The hydrochloride is used in rubber-Amm perchlorate solid proplnts in amounts of from 0.1 to 10% as a burning rate depressant. At 300psi chamber press the hydrochloride is reported to effect a 31% depression in the burning rate (Ref 6)

Semicarbazide Nitrate. $\text{CH}_5\text{ON}_3\cdot\text{HNO}_3$; mw 138.09; N 40.58%; OB to CO_2 -23.17%; colorl plates; mp 123° (decompn). V sol in w. Prepn is by evapn at 40° of a mixt of the semicarbazide with dil nitric acid. The nitrate puffs off on rapid heating (Refs 1, p 100; 2 & 3)

Semicarbazide Perchlorate. $\text{CH}_5\text{ON}_3\cdot\text{HClO}_4$; mw 159.53; N 26.35%; OB to CO_2 0%; colorl cryst; mp 278° (explds). Prepn is by reacting the semicarbazide with concd perchloric acid (Ref 5)

Refs: 1) Beil 3, 98, (47), [80] & {187} 2) T. Curtius & K. Heidenreich, Ber 27, 56 (1894) 3) Ibid, JPraktChem 52, (2), 465 (1895) 4) R.L. Datta & J.K. Choudhury, JACS 38, 2737 (1916) & CA 11, 336 (1917) 5) R.L. Datta & N.R. Chatterjee, JCS 115, 1010 (1919) & CA 14, 226 (1920) 6) G.D. Sammons, "Composite Propellants Containing a Burning-Rate Depressant", USP 3026672 (1962) & CA 56, 14521 (1962) 7) Merck (1976), 1093 (No 8191) 8) CondChemDict (1977), 769 9) ChemRubHdb (1978), C-495

Semiconductor Explosive Initiator. By replacing the conventional metallic wire with a semicon-

ductor cryst of selected shape and electrical characteristics, an initiator with the following desirable features is claimed: 1) fire-no fire voltages can be detd within a few percent, giving max protection from spurious signals; 2) the expl force of the cryst is sufficient to deton PETN or RDX directly without a primer charge; 3) the device can be nondestructively tested without fear of deton; 4) the speed of response is greater than wire devices; 5) the radar sensitivity is a factor of 8 less than wire devices; and 6) a wide range of electrical parameters is possible allowing for low voltage high performance initiation

These features are achieved by using a single cryst with the characteristics of increasing resistivity with applied current up to a "turnover point", where the resistivity drops sharply. The cryst disintegrates releasing a shock wave igniting the expl

Refs: 1) L.E. Hollander, USP 3366055 (1968)
2) G. Cohn, Ed, *Expls&Pyrots* 9 (5) (1976)

Semifixed Ammunition. Ammo in which the cartridge case is not permanently fixed to the projectile, so that the zone charge (qv) within the cartridge case can be adjusted to obtain the desired range. It is loaded into the weapon as a unit

See also under "Ammunition: Complete Round of" in Vol 1, A385-L
Ref: Anon, *OrdnTechTerm* (1962), 269-L

Semi-Gelatine Explosives. A type of "hybrid" expl designed to bridge the gap between high-density ammonia Dynamites and ammonia (or extra) gelatines. It is a good general-purpose cartridge HE with considerable economic advantages, suitable for use underground (Ref 2) (Also see "Blasting Gelatin" in Vol 2, B211-R; "Gelatin (Explosive)" in Vol 6, G44-R; and "Gelatine Dynamites" in Vol 6, G48-L to G50-R)

The strength of NG powder expls (NG, a combustible material such as sawdust, AN, sometimes Na nitrate) is limited to about 80% of Blasting Gelatine, and its d to approx 1 g/cc. To achieve greater concns of energy it is necessary to increase the NG to an extent such that it can no longer be absorbed by the ingredients of

the powder expls. When this stage is reached, NC must be added to the NG to prevent exudation from the expl cartridges. This leads to the *semi-gelatine* type of expl which forms a rather indistinct class between the powders and the gelatines. The true powder expls contain no NC and, therefore, can only be made at relatively low densities, and are also susceptible to the action of w. The true gelatine expls, on the other hand, have a continuous phase of gelled NG and, therefore, have a high d and are relatively unaffected by w for appreciable lengths of time. Semi-gelatine expls can be made with proportions of NG from 10-30% and with properties which range over the extreme limits between powders and gelatines

The choice of compn of a semi-gelatine depends ultimately on two requirements, namely, the strength required and the resistance to w needed for the particular application. For economic reasons the lowest NG content which satisfies both these requirements is always chosen

With mixts of AN and ordinary combustibles, the highest weight strength which can readily be achieved is about 85% of Blasting Gelatine. To obtain high bulk strength it is, therefore, necessary to increase the d to the max possible. In practice, the max d usefully achieved is about 1.25g/cc, and this with relatively dense combustibles means a NG content of 15-20%. If either the AN or the combustible available is not of high d, increased quantities of NG may be necessary. As with powder expls, Al may be added to give extra power, although this is not necessarily economic

An expl designed as above would give very satisfactory results for many purposes when used in dry or almost dry conditions. Underground, however, boreholes are frequently very wet and in work above ground running water is often encountered. Semi-gelatine expls can be considerably improved in their w resistance by adding one or other of certain well known waterproofing agents (carboxymethylcellulose, starches, or natural gums) (Ref 1)

The trade names of semi-gelatine expls produced by various North American manufacturers are listed below (Ref 2):

<u>Manufacturer</u>	<u>Trade Names</u>
Apache Powder Co	Amogel
Atlas Chemical Industries Inc	Gelodyn
Canadian Industries Ltd	Dygel, Cilgel
E.I. DuPont deNemours & Co, Inc	Gelex
Gulf Oil Co (US)	Semi Gelatin
Hercules Inc	Gelamite
Independent Explosives Co of Pa	Mighty Gel

Refs: 1) S. Fordham, "High Explosives and Propellants", Pergamon Press, NY (1966), 56-57 2) C.E. Gregory, "Explosives for North American Engineers", Trans Tech Publications, Cleveland (1973), 45-46 & 51

Semipyrophoric Metals. A patented mfg process which converts metals such as Fe, Co, Ni, Cu, etc, in the form of their oxides or oxalates to a semipyrophoric form which ignites in air between 100° and 350°. The process is such that a completely pyrophoric form is *not* obtd. The prepn procedure may vary in several ways: a) a metal (oxide) compd is converted to the pyrophoric condition as a lower oxide which is then converted into the semipyrophoric condition by slow exposure to air or dil O₂ or by treatment with an O₂-free gas, or b) by introducing a pyrophoric lower oxide into an organic liq, ie, methanol, eth, aldehydes or esters and either evapg the liq or working up the suspension into a semipyrophoric compn

Examples of the variation of process "a" from the refs include: 1) semipyrophoric FeO is obtd by heating ferrous oxalate to 390-410° for 10-11 mins in a tube in which air has been replaced by N₂ and then cooling; 2) semipyrophoric FeO can also be produced by reducing ferrous oxalate in a stream of H₂ at 400° for 1 hr

See also "Pyrophoric Incendiary Agents" in Vol 8, P502-L to P504-R

Refs: 1) O. Wyss, "Semipyrophoric Metals", GerP 595069 (1934) & CA 29, 1252 (1935) 2) A. Schmid, "Semipyrophoric Iron", USP 2096009 (1938) & CA 32, 104 (1938) 3) O.F. Wyss, "Semipyrophoric Metal Oxides and Compositions", BritP 502965 (1939) & CA 33, 7501 (1939) 4) A. Schmid, "Semipyrophoric Iron", USP 2207879 (1940) & CA 34, 7840 (1940)

Simple Plunger. A centrifugal plunger, named for the inventor, which operates to maintain a fuze in a safe condition until centrifugal force unlocks and moves the firing pin into the armed position

Ref: Anon, OrdnTechTerm (1962), 269-R

Sengite. A South African rock blasting expl consisting of guncotton, Na nitrate and a considerable amt of moisture. It was so insensitive as to require a Gelignite or TNT booster

Ref: J.P. Udal, SAfricanJInds 1, 988-89 (1918) & CA 12, 2442 (1918)

Sensibilité à l'amorce (Fr). See under "Essais d'Explosifs" in Vol 5, E140-L

Sensibilité au choc du mouton (Fr). See under "Essais d'Explosifs" in Vol 5, E139-L

Sensibilité à la friction (Fr). See under "Essai à la friction" in Vol 5, E136-L

Sensibilité à l'inflammation (Fr). See under "Combustion en tas conique" in Vol 5, E138-R

Sensibilité à l'onde explosive (Fr). See under "Transmission de la détonation à distance" in Vol 5, E140-L

Sensitiveness or Sensitivity of Explosives. See under "Initiation" in Vol 7, I106-L to I109-L

Sentinel. A US anti-ballistic missile (ABM) system program proposed in 1967 and replaced by the **Safeguard** (qv) program. Both were based on the same components, but whereas Sentinel was primarily oriented against a 'Chinese' attack (only ICBMs, coming over the North Pole) against 25 selected US cities, Safeguard was intended to provide an all-round defense primarily to defend the Minuteman (qv) silos and bomber bases of US deterrent forces as well as the

Washington command centers. Safeguard also offered a 'thin' area defense capability against a small or unsophisticated 'Chinese' ICBM strike
Ref: E. Luttwak, "A Dictionary of Modern War", Harper & Row, NY (1971), 174-L

Separated Ammunition. Ammo characterized by the arrangement of the propelling charge and the projectile for loading into a gun. The propelling charge, contained in a primed cartridge case that is sealed with a closing plug, and the projectile, are loaded into the gun in one operation. Separated ammo is used when the ammo is too large to handle as fixed ammo. See also under "Ammunition and Weapons or Arms" in Vol 1, A385-L

Ref: Anon, OrdTechTerm (1962), 270-L

Separate Loading Ammunition. Ammo in which the projectile, propellant charge (bag loaded), and primer are handled and loaded separately into the gun. No cartridge case is utilized. See also under "Ammunition and Weapons or Arms" in Vol 1, A385-L

Ref: Anon, OrdTechTerm (1962), 270-L

Séranine (Swed). Expl patented in 1867 by E.A. Bjökmann contg NG 18.12, AN 72.46, purified sawdust or charcoal 8.70, and benz or creosote 0.72% (Refs 2 & 3). The same term is applied by Cundill (Ref 1) and Guia (Ref 4) to all Dynamites contg NG and K chlorate
Refs: 1) J.P. Cundill, MP 6, 94 (1893)
 2) Daniel (1902), 713 3) R. Escalles, SS 1, 456 (1906) 4) Guia, Trattato 6 (1959), 400

Sergeant. A US field artillery ballistic missile, capable of carrying either a nuclear or a HE warhead, and intended to provide missile support to a corps or field army. A second-generation system, it replaced the Corporal missile in 1961, and among the improvements were inertial guidance and solid propellant propulsion. These features reduced the amount of ground handling equipment required by the system and resulted in a shorter reaction time than that of the command-guided liquid-fueled Corporal

The missile is composed of four major sections, the warhead, guidance, rocket motor and control unit. These are assembled just before firing and are transported to the firing position in special sealed containers. The guidance system is immune to known countermeasures

The Sergeant's military designation is MGM/29A; its length is 10.5m, diameter 79cm, launch wt 4536kg, speed supersonic, and range 45 to 140km

Refs: 1) E. Luttwak, "A Dictionary of Modern War", Harper & Row, NY (1971), 174

2) J. Quick, "Dictionary of Weapons and Military Terms", McGraw-Hill, NY (1973), 393

3) R.T. Pretty, Ed, "Jane's Weapon Systems—1977", Franklin Watts, NY (1976), 53–54

Serpentine Powder. BlkPdr ground dry to a flourlike compn. At about the middle of the fifteenth century it was supplanted by *corned powder* (See also under "Black Powder or Gunpowder" in Vol 2, B169-L)

Ref: J. Quick, "Dictionary of Weapons and Military Terms", McGraw-Hill, NY (1973), 394

Service Ammunition. Ammo intended for combat, rather than for training purposes

Ref: Anon, OrdnTechTerm (1962), 270-L

Service des Poudres et Saltpêtres (Fr). See under "Commission des Substances Explosives" in Vol 3, C460-L

Service Life. Use age of the unit at the time of retirement. See also under "Life of Guns" in Vol 7, L14-L

Ref: Anon, "Dictionary of United States Army Terms", AR310-25, C1 (1977), 247-L

Service Velocity. The muzzle velocity established as the velocity to be attained by a projectile of standard wt, under standard conditions of temp, when fired from a new gun of the designated type. Range tables are computed on the basis of this velocity

Ref: Anon, OrdnTechTerm (1962), 270-R

Servomechanisms. Servomechanisms are part of a broad class of systems that operate on the principle of feedback. In a feedback control system, the output (response) signal is made to conform with the input (command) signal by feeding back to the input a signal that is a function of the output for the purpose of comparison. Should an error exist, a corrective action is automatically initiated to reduce the error toward zero. Thus, thru feedback, output and input signals are made to conform essentially with each other

In practice, the output signal of a feedback control system may be an electrical quantity such as a voltage or current, or any one of a variety of physical quantities such as a linear or angular displacement; velocity, pressure, or temp. Similarly, the input signal may take any one of these forms. Moreover, in many applications, input signals belong to one of these types, and the output to another. Suitable transducers or measuring devices must then be used. It is also common to find multiple feedback paths or loops in complicated feedback control systems. In these systems, the over-all system performance as characterized by stability, speed of response, or accuracy can be enhanced by feeding back signals from various points within the system to other points for comparison and initiation of correction signals at the comparison points

At present, there is no standard definition of a servomechanism. Some engineers prefer to classify any system with a feedback loop as a servomechanism. According to this interpretation, an electronic amplifier with negative feedback is a servo. More frequently, however, the term servomechanism is reserved for a feedback control system containing a mechanical quantity. Thus, the IRE defines a servomechanism as "a feedback control system in which one or more of the system signals represents mechanical motion". Some would restrict the definition further by applying the term only to a special class of feedback control system in which the output is a mechanical position

Servomechanisms are an important part of nearly every piece of modern mechanized Army equipment. They are used to automatically position gun mounts, missile launchers, and radar antennas. They aid in the control of the flight paths of jet-propelled rockets and ballistic

missiles, and play an important role in the navigational systems of those vehicles. As instrument servos, they permit remote monitoring of physical and electrical quantities and facilitate mathematical operations in computers.

No single set of electrical and physical requirements can be stated for servomechanisms intended for these diverse military applications. The characteristics of each servomechanism are determined by the function it is to perform, by the characteristics of the other devices and equipments with which it is associated, and by the environment to which it is subjected. It will often be found that two or more servo-system configurations will meet a given set of performance specifications. Final choice of a system may then be determined by such factors as ability of the system to meet environmental specifications, availability of components, simplicity, reliability, ease of maintenance, ease of manufacture, and cost

Refs: 1) Anon, "Servomechanisms, Section 1, Theory", **AMCP 706-136** (1965) 2) Anon, "Servomechanisms, Section 2, Measurement and Signal Converters", **AMCP 706-137** (1965) 3) Anon, "Servomechanisms, Section 3, Amplification", **AMCP 706-138** (1965) 4) Anon, "Servomechanisms, Section 4, Power Elements and System Design", **AMCP 706-139** (1965)

Setback Acceleration. Setback is the relative rearward force of component parts in a projectile, missile, or fuze undergoing forward acceleration during its firing or launching. This tendency to move is caused by the setback force, the rearward force of inertia that is created by the forward acceleration of the projectile or missile. The force is directly proportional to the acceleration and mass of the parts being accelerated

Table 1 lists some typical magnitudes of acceleration to which weapons are subjected in the course of their use. More specific data are usually available to the designer of components for a particular application. Effects of these accelerations on inert components may be computed by conventional applied mechanics (Ref 7). Failure of mechanical components as a result of acceleration-induced stresses may, of course, result in the application of impact of sufficient

magnitude to initiate an expl charge. Some types of expl charge, including shaped charges for example, are strongly dependent upon both configuration and point of initiation for their effectiveness. The expl material is part of the structure which maintains such configuration

Table 1
Values of Acceleration in Ammunition

Ammunition and Condition of Exposure	Typical Peak Acceleration, g	Direction
Projectile setback when fired in gun	50,000	Axial
Projectile piercing armor	-150,000	Axial or Oblique
Projectile loaded into automatic gun	-1,000	Axial
Projectile loaded into artillery	10,000	Transverse
Rocket or missile, normal launch	100	Axial
Rocket or missile, gun launched	30,000	Axial
Missile steering	40	Transverse
Missile flight vibration	10	Random
Mine water entry	-2,500	Axial

Note: Forward acceleration is conventionally assigned a positive value

Typical setback accelerations experienced by projectiles are of the order of 30,000 times that of gravity (Ref 8). The acceleration increases from zero to its max value (see Fig 1) in a few milliseconds

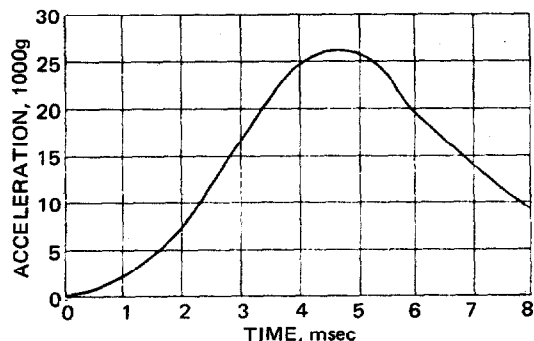

Fig 1 Typical Time-acceleration Curve for Projectile While in Gun

In addition to this very specific acceleration that causes setback, there are several other accelerations of similar magnitude to which this discussion applies. The axial force in the direction opposite to setback has been designated as *setforward*. It is the forward force of inertia that is created when a projectile, missile, or bomb decelerates. Deceleration occurs on water entry and target impact. Setforward also occurs when projectiles are rammed into an automatic weapon. Present point-detonating, time, and proximity fuzes will withstand about 1000 g setforward. While weapon designers would like to double or triple the ram velocity, present fuzes cannot survive this force (Ref 8)

A sideways acceleration occurs because of the practical inability to achieve perfect alignment between projectile and gun axis prior to firing. Therefore, upon firing, a sideways force results as the projectile aligns itself with the bore. For example, the 175mm field gun and the 120mm tank gun have such high lateral forces that fuze ogives have broken off. Hence, special fuzes had to be provided. These forces have not been measured or calculated to date. In air-gun and drop tests, damage was simulated by accelerations greater than 10000 g. Worn gun tubes also produce greater than normal sideways acceleration; the word describing this motion is *balloting*

To simulate the conditions experienced by the filler of a projectile during acceleration in a gun, the apparatus shown in Fig 2 (Ref 1) was developed. By the action of the propellant, a pressure pulse is transmitted to an expl specimen thru the piston system that closely resembles setback. The criterion for each expl tested is the max pressure at which the expl cannot be initiated, when at an initial temp of 125°F, in 25 or more trials. Setback sensitivity data so obtained for various expls are listed below:

Explosive	Setback Critical Pressure, k psi (from Ref 4)
Composition B	87.5
Cyclotol, 60/40	76.6
Octol, 75/25	82.0
TNT	86.0
Tritonal, 80/20	87.0

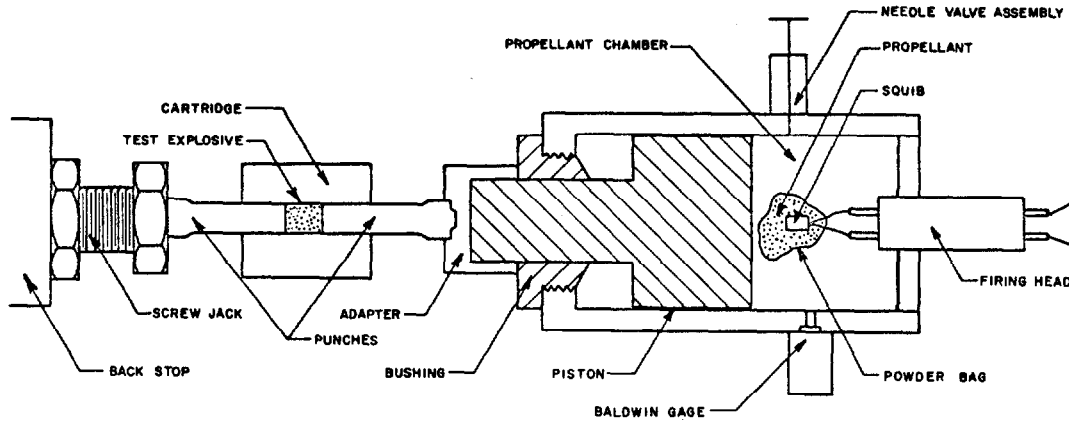

Fig 2 Apparatus Which Simulates Setback Pressure

The Setback Mechanism. The duration of the setback acceleration period is long compared with the transit time for a compression wave in the material, but short compared with the time required for significant heat transfer. Thus the compression that results may be considered to be essentially adiabatic. As soon as the physical mechanism of setback is understood to be adiabatic compression, it becomes clear how explosives can be initiated by setback. Hot spots are caused by the adiabatic compression of minute air spaces within the explosive (See also under "Hot Spots" in Vol 7, H170 ff)

The adiabatic compression of the air results in a build-up of high temps. The temps reached can be approximated by treating the air as an ideal gas

$$\frac{T_2}{T_1} = \left[\frac{P_2}{P_1} \right]^{(\gamma-1)/\gamma}$$

where:

T_2 = final temperature, °K

T_1 = initial temperature, °K

P_2 = final pressure, psi

P_1 = initial pressure, psi

γ = ratio of specific heats, dimensionless
(1.4 for air)

Even at comparatively low setback pressures, some of the temps so calculated are considerably above the 5-sec expln temp of common expls, see Table 2 (Ref 2)

While the temp reached by the compressed air is high, the total heat available in the thin layer of compressed air is minute. Hence, a minimum base separation must be present at

any given pressure to initiate an expl. The separation of the charge from the projectile was simulated by separation of a plunger from the specimen in a test apparatus. Critical setback pressures are substantially reduced as the separation is increased (see Table 3, Ref 2)

Table 2
Temperatures Reached by Air
When Compressed Adiabatically

Setback Pressure, psi	Temperature, °F
1,000	1,480
2,000	1,910
5,000	2,620
10,000	3,330
20,000	4,120
50,000	5,490
100,000	6,800

Table 3
Critical Setback Pressures of Explosives
of Various Base Separations

Explosive	Pressure, psi*		
	No Separation	1/16 inch Separation	1/8 inch Separation
Composition B	87,500	32,000	11,200
Cyclotol 75/25	82,000†	31,500	—
TNT	86,000	37,000	19,500
Tritonal 80/20	87,000	—	—

*Maximum setback pressure at which explosive cannot be initiated at 125°F in 25 or more shots

†Extrapolated 0% point

If the expl is considered to behave as a fluid, the pressure at the base of the charge cavity is essentially the weight of a column of expl of unit area and length equal to that of the expl charge, multiplied by the acceleration

$$P = 0.036\rho aL, \text{ psi}$$

where:

P = pressure at base of charge cavity, psi

ρ = density of expl charge, g/cm³

a = acceleration, number of g's

L = length of expl charge, inches

In a typical projectile with an expl charge of Composition B ($\rho = 1.7\text{g/cc}$), 10 inches long, the pressure at 30000 g's would come to about 18300psi. Since this pressure is several times the 2200 to 3000psi compressive strength for Composition B, the assumption of fluid behavior is quite valid

The setback initiation pressure drops linearly with increasing temp to zero at the cook-off temp. This increase in sensitivity with increasing temp can raise the probability of bore pre-matures where projectiles are left in hot gun chambers for appreciable periods before firing

Findings that cavities such as bubbles, incidental to the casting process, and grit inclusions can cause substantial reduction in critical setback pressures have resulted in the following suggested provisions in projectile loading standards (Refs 3, 5 & 6): 1) no cavities should be permitted at the interface of expl charge and inside base of the projectile; 2) no cavity should be permitted in the expl charge close to its base; 3) no grit should be permitted in the projectile; and 4) no projectile with deep gouges on the interior surface at the base area should be accepted

Refs: 1) L. Jablansky, "Laboratory Scale Test Device to Determine Sensitivity of Explosives to Initiation by Setback Pressure", PATR 2235 (1955) 2) R.L. Wagner & M.E. Pollack, "Development of an Impact Sensitivity Test for Cast and Pressed Explosives", PATR 2290 (1956) 3) L. Jablansky, "Factors Affecting Sensitivity of Composition B to Setback", PATR 2433 (1957) 4) R.W. Heinemann & R.T. Schimmel, "Sensitivity of Explosives to Setback Pressure", PATR 2572 (1958) 5) S.D. Stein, "Proposed Shell Loading Standards Based on a Statistical Study of Setback Sensitivities", ExplsDevSect Rept 63, FREL, Picatinny Arsenal (May 1959)

6) 3rd ONRSympDeton, Rept ACR-52 (1960)
7) Anon, EngrgDesHndbk, "Ammunition Series, Fuzes", AMCP 706-210 (1969) 8) Anon, EngrgDesHndbk, "Ammunition Series, Section 4, Design for Projection", AMCP 706-247 (1970)

Setting Ring. Part of a mechanical fuze setter that takes hold of a fixed ring on the fuze of a projectile. It then rotates the entire projectile except for a small ring, or setting element, in the fuze. This setting element is kept from turning by the adjusting ring in the fuze setter just long enough to make the desired change in the setting of the fuze

Ref: Anon, OrdnTechTerm (1962), 271-R

Settling Rounds. Rounds fired at varying angles of elevation to seat the spade and base plate of a gun mount firmly in the ground

Ref: Anon, OrdnTechTerm (1962), 271-R

Sevranites. Fr plastic explosives developed in 1946 to offset an acute shortage of NG and Dynamites. For details see under "Cheddites or Streetites" in Vol 2, C159-R (text and Table 5)

Sévrán-Livry, Explosif de. Fr blasting expl prepd by thoroughly blending 60p of AN and 40p of NC in 24p of w. After drying at 60°, the mixt was loaded into paraffined paper cartridges and sealed to protect from moisture
Ref: Daniel (1902), 714

SEX (or QDX). See under "QDX" in this Vol and in Vol 1, A49-R to A50-L

Shadow (Silhouette) Method in Ballistics. See under "Cameras, High-Speed Photographic" in Vol 2, C16-L

Shaped Charge Effect. See under "Detonation, Munroe-Neumann Effect (or Shaped Charge Effect) and Lined-Cavity Effect In" in Vol 4, D442-R to D454-L

Addnl Information from Ref 4:

"The lined shaped charge is one of the most effective means for the defeat of armor in terms of the ratio of thickness penetrated to diameter of round. Much information is available on the design of shaped charges (Refs 1 & 3). Operation is as follows. At the detonation front, the metal liner is deflected inward. Converging symmetrically toward the centerline, the metal is deflected along this line. The slug of metal which accumulates at the center is squeezed by the continuing convergence to such high pressures that part of it emerges in a jet, like toothpaste from a tube

Because the theory of shaped charges is based on a number of simplifying assumptions and because of unavoidable variations introduced during manufacture and loading, a large part of design and development of shaped charges has been empirical. The following rules of thumb on the design of shaped charges, are consistent with the theory although they might not be quantitatively predictable: 1) the optimum cone (included) angle, for most purposes, is about 42 deg; 2) maximum penetration is obtained with a stand-off distance between charge and target of 2 to 6 cal; 3) the cone liner material that seems to have the best combination of properties is soft copper, although mild steel and aluminum have been used to advantage; 4) optimum cone liner thickness is about 0.03 cal for copper; 5) detonation pressure seems to be the most important property of an explosive affecting shaped charge performance; 6) in spin-stabilized projectiles, the centrifugal forces are sufficient to impair shaped charge performance significantly. This may be counter-balanced, at least to some extent by use of fluted and trumpet shaped liners; 7) as the cone angle becomes larger, the velocity of the jet decreases and that of the slug increases. Shallow shaped charges in which the slug is the effective output are referred to as Misznay-Schardin charges. They are used extensively in land mines; 8) as the cone angle becomes smaller the velocity of the jet becomes higher and its mass becomes smaller until, for a tube, they approach infinity and zero, respectively; and 9) although penetrations by shaped charges in armor plate as high as 11 cal have been observed in the laboratory, the limit for practical ammunition is closer to four or five

cone diameters

For information on shaped charge scaling, see Ref 2"

Refs: 1) Anon, "Transactions of Symposium on Shaped Charges", BRL Rept 985, Aberdeen Prov Grnd (May 22-24, 1956) 2) O.A. Klamer, "Shaped Charge Scaling", PATM 1383 (1964) 3) Anon, EngrgDesHndbk, "Ammunition Series, Design for Terminal Effects (U)", AMCP 706-245 (1974) (Confid) 4) Anon, EngrgDesHndbk, "Explosives Series, Explosive Trains", AMCP 706-179 (1974), 3-17 to 3-18

Sharp and Smith Powder. Expl patented in Engl in 1866 contg K nitrate, chlorate, ferricyanide, carbonate and S. See refs under "Chlorate Explosives" in Vol 2, C206-R

Shattering Effect. See under "Brisance or Shattering Effect" in Vol 2, B265-L to B300-R

Shear Pin. 1) a pin or wire provided in a fuze design to hold parts in a fixed relationship until forces are exerted on one or more of the parts which cause shearing of the pin or wire. The shearing is usually accomplished by setback or set forward (impact) forces. The shear member may be augmented during transportation by an additional safety device; 2) in a proplnt actuated device, a locking member which is released by shearing — called "shearing pin" in this sense; 3) in a power train, such as a winch, any pin, as thru a gear and shaft, which is designed to fail at a predetermined force in order to protect a mechanism

Ref: Anon, OrdnTechTerm (1962), 272-L

Sheathed Explosives. See under "Commercial or Industrial Explosives" in Vol 3, C450-R to C459-R, "Low Energy Detonating Cord (LEDC)" in Vol 7, L58-L and "Primacord" in Vol 8, P372-L

Sheet Explosives. See under "Detasheet Flexible Sheet Explosives" in Vol 3, D99-L to D101-L, and "Flexible Explosives" in Vol 6, F107-L

Shelf Life. The total period of time, beginning with the date of manuf/cure/assembly that an item may remain in the combined wholesale (including manufacturer) and retail storage system and still remain suitable for issue to, and use by the end user. Shelf life is not to be confused with *service life* (qv) which is a measurement of anticipated total in-use time
Ref: Anon, "Dictionary of United States Army Terms", AR310-25, C1 (1977)

Shell. See under "Ammunition and Weapons or Arms" in Vol 1, A383-L to A391-L, and "Projectiles" in Vol 8, P391-R to P396-R

Shell Filling or Loading. See under "Loading and Fabrication of Explosives" in Vol 7, L46-L to L57-L

Shell Fragmentation. See subjects from "Fragmentation" thru "Fragment Velocity Measurements" in Vol 6, F180-L to F182-L

Shellac. See under "Gum Lac or Shellac" in Vol 6, G187-L

Shellite. Brit WWII expl, same as US 70/30 Tridite (qv), contg 70% PA and 30% 2,6-Dinitrophenol (DNPh). It was used to cast load AP (armor piercing) bombs and shells. Its properties were: yellow cream colored solid; d 1.62g/cc; mp 83°; ballistic strength, 91% TNT; brisance, 38.5g sand crushed vs 43.0g for TNT; expl temp, 300-15°; impact sensitivity, PicArns app with 2kg wt, 14" vs 14" for TNT; rifle bullet impact, 0 to 20% detonations from impact of .30 cal bullet fired from a 90' distance; stability, compatibility of metals, sol and toxicity, same as PA (Ref 1)

Ref 2 lists a formulation contg 53.0% PA, 41.0% DNPh and 6.0% picramide as Shellite. Mp 77°, d 1.56g/cc at 78.2°. The ref states that its "crystallization velocity" was small, permitting cast loaded charges to be obtained practically without cavities

Refs: 1) All&EnExpls (1946), 100 2) A.N.

Campbell et al, CanJRes 25B, No 3, 211-15 (1947) & CA 41, 7220 (1947)

Shillelagh (SMGM-51A). US lightweight close-support army guided weapon system intended primarily for use in a ground-to-ground role but suitable also for air-to-surface launching from helicopters. It is a direct-fire missile which can be carried by a variety of land vehicles ranging from armored reconnaissance vehicles to main battle tanks

The Shillelagh is powered by a solid fuel rocket motor and controlled by hot gas jet reaction. The warhead is an Octol (see Vol 8, O6-R to O17-L) HEAT (shaped) charged. The missile length is 1.14m, diameter 152mm, and launch wt 27kg

Shillelagh is capable of high accuracy against both stationary and moving targets. The missile is fired from a 152mm dual-purpose gun and missile launcher which can also fire conventional ammo. It is fired by a gunner, who guides the missile to its target using an infra-red command guidance system. He points the cross hairs at the target and follows the target during the missile flight to the point of impact. A missile tracker associated with the gunner's telescope measures the deviation of the missile's flight path from the line of sight, and the resultant signals are converted into commands that are transmitted by the infra-red transmitter to the missile receiver. Here the commands are translated into actuation signals for the jet reaction flight controls. The missile is fitted with flip-out fins which open when it leaves the launcher
Refs: 1) E. Luttwak, "A Dictionary of Modern War", Harper & Row, NY (1971), 176-L
 2) R.T. Pretty, Ed, "Jane's Weapon Systems-1977", Franklin Watts, NY (1976), 44-45

Shimose or Shimoza. Japanese term for Picric Acid, named in honor of Captain I. Shimose, who developed a method for casting PA into shells at the beginning of the century. These shells were successfully used during the Russo-Japanese War, at which time the Russian shells contained pressed NC contg about 18% moisture. Also see "Picric Acid" in Vol 8, P285-R to P295-L

Refs: 1) Anon, MAF 12, 1036 (1933)
 2) J. Quick, "Dictionary of Weapons and Military Terms", McGraw-Hill, NY (1973), 449 (under "Trinitrophenol")

Shipping Commercial Explosives. In the US the safe transport of hazardous materials is the responsibility of the shipper. Shipping regulations are complex and a qualified shipper is needed to cope with them. The shipper must be properly licensed in all states and countries involved. It has become expedient to pack and label hazardous materials to protect life, property and the cargo itself. All cargo must be properly blocked and braced during shipment; for some hazard classes, the vehicle must be placarded and inspected. Mixed shipments in the same vehicle must be compatible. In case of an accident on any mode of shipping, Form F5800 must be filed with the Dept of Transportation when the incident involves death or serious injury, \$50,000 property damage, or continuing danger (Refs 1 & 2)

Some considerations for specific modes of shipping follow:

By Rail. Railroad shipment of hazardous materials is covered in Dept of Transportation Tariff No 23 (Ref 3)

By Truck. Motor vehicle shipment of hazardous materials is covered in Dept of Transportation Tariff No 11 (Ref 4). Motor vehicle shipment is more complex than rail shipment. A train is made up of many cars watched over by an engineer in front and caboose personnel behind. The engineer is in voice communication with the tower; the railroad controls traffic over its route and provides trained inspectors. In contrast, each truck is an independent unit. It has no control over traffic on the public highway and the driver must cope with any situation which may arise. Hence, drivers of hazardous materials are given careful training and detailed instructions, and the vehicle is carefully inspected for safety (lights, brakes, etc) and compliance with local laws (wt limit, etc)

By Ship. All water shipment is regulated by the Coast Guard (Ref 5). There are many restrictions to the transport of hazardous materials by ship that must be taken into account. Some dangerous articles are not permitted on passenger-

carrying vessels. Also, many ports do not permit the anchorage of vessels carrying dangerous articles. The Army Corps of Engineers has therefore established suitably isolated expls anchorages at various ports

By Air. Aircraft shipment of hazardous materials is covered by Dept of Transportation Tariff No 6D (Ref 6). As in ship transportation, dangerous cargo is prohibited on passenger-carrying craft

Refs: 1) G. Cohn, Ed, Expls&Pyrots 4, No 8 (Aug 1971) 2) Ibid 5, No 1 (Jan 1972)

3) **Tariff 23**, "Regulations for Transportation of Explosives and Other Dangerous Articles by Land and Water in Rail Freight Service and by Motor Vehicle (Highway) and Water, Including Specifications for Shipping Containers", Agent T.C. George, 2 Pennsylvania Plaza, New York, NY 10001 4) **Tariff 11**, "Regulations for Transportation of Explosives and Other Dangerous Articles by Motor, Rails, and Water, Including Specifications for Shipping Containers", Agent F.G. Freund, American Trucking Assn, Inc, 1616 P St, NW, Washington, DC 20036 5) **CG 108**, "Rules and Regulations for Military Explosives and Hazardous Munitions", US Coast Guard, 400 7th St, NW, Washington, DC 20591 6) **Tariff 6-D**, "Official Air Transport Restricted Articles Tariff", C.C. Squire, Airline Tariff Publishers, Inc, Agent, 1825 K St, NW, Washington, DC 20006

Shock Phenomena. See topics in Vol 4, D515-R to D547-L

Shock Sensitivity of Explosives

I Introduction

There is some confusion about what is meant by *Shock Sensitivity*. In this article we will define shock sensitivity as the reaction of *condensed* expls in time frames of microseconds to shocks whose amplitude is generally in the kilobar range. Furthermore, *shocks* are defined as steep-fronted compression waves that propagate at supersonic velocities in the medium that they traverse. Thus the article will be limited primarily to consideration of the effects of explosively generated shocks

on either liq or solid expls. Missile impact phenomena will not be considered unless missile impact is at velocities high enough to generate strong shocks in the impacted expl. Similarly LVD (low velocity detonation) phenomena will be excluded even though they depend on shock effects for their propagation

In what follows frequent reference will be made to *acceptors* and *donors*. Acceptors are test samples of the expl subjected to shocks and donors are the shock generating systems. Unless otherwise specified, liq expls and single crystals of solid expl will be considered as *homogeneous* materials, and all "poured", pressed or cast solid expls will be considered as *heterogenous* materials. As will become apparent, there are pronounced differences in the shock behavior of homogeneous and heterogenous expls

If one recalls that a detonation is a chemically-supported shock it becomes obvious why consideration of shock effects is so important in the design of reliable initiation systems for military as well as commercial applications. Indeed almost all initiation schemes rely on the shock produced by a *primer-booster* combination to detonate the *main charge* of an expl device. An initiation system that generates too weak or too brief a shock in the main charge of a bomb will result in a dud, or in a misfire if this system is applied to a commercial blasting charge

The understanding of shock phenomena in expls is also very important from a safety point of view. It is the prime consideration in avoiding *sympathetic detonation*, ie, the detonation of nearby *acceptors* by the *accidental* detonation of a *donor*. On the other hand, controlled sympathetic detonation is sometimes desirable, eg, in blasting ditches or trenches in wet ground by initiating one charge conventionally and having the shock from this charge propagate thru the ground to initiate a neighboring charge which then initiates its neighbor and so on

In the next section we will present a brief review of shock phenomena. Section III will describe exptl methods of determining shock sensitivity. Factors affecting shock sensitivity will be discussed in Section IV. Representative shock sensitivity data will be presented in Section V. Sections VI and VII will consider the mechanisms of shock initiation for homogeneous

and heterogenous expls, respectively. Section VIII will contain a brief description of the effects of shocks on deflagration phenomena. References, primarily to modern literature, will be given in Section IX

II Review of Shock Phenomena

An idealized plane shock is characterized by its propagation velocity U , particle velocity u , density ρ (or specific volume which is $1/\rho$), peak pressure P , and the internal energy E and temp T immediately behind the shock front. As discussed in Vol 7, H179, the Hugoniot equations (or more correctly Rankine-Hugoniot), the simultaneous measurement of any two of the above variables is sufficient to determine all the rest provided conditions ahead of the shock (u_0, P_0, ρ_0, E_0 & T_0) are known. Thus, for mathematical convenience but closely approximated in reality, the shock abruptly divides virginal (unshocked) material from shocked (compressed) material. For the reader's convenience, because we will refer to them frequently, this is illustrated in two graphs taken from the above Vol 7 article. They show the transmission of a shock from one material to another (script S's are shocks and script R's are rarefactions)

All of the above was based on continuum hydrodynamics and is strictly applicable only to shocks in perfectly homogenous media. For heterogenous media, with which we will be mostly concerned in this article, the Hugoniot relationships can at best describe only the gross macroscopic behavior of shocked heterogenous expls. Furthermore, these relations presume that there is no chemical reaction at the front of the shock in an expl medium. This may not always be true for powerful shocks in low density granular expls

Shock impedance is the product $\rho_0 U$ and graphically it is represented by the slopes of the broken lines in Figs 1 & 2. Note that in Fig 1 the reflected wave is a rarefaction rather than a shock

As will be shown in the next section, in many exptl determinations of shock sensitivity the input shock travels thru an inert medium (barrier) before it enters the test sample. In some of the early studies of shock sensitivity of expls, shocks were characterized by their propagation velocity U in the inert barrier (Ref 2). As will be shown

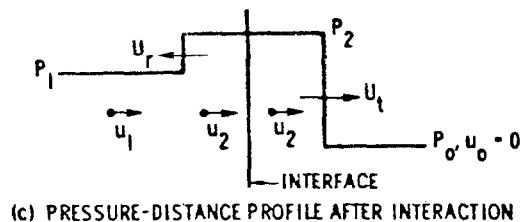
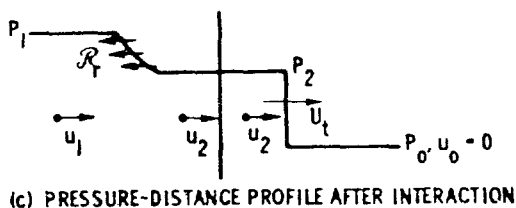
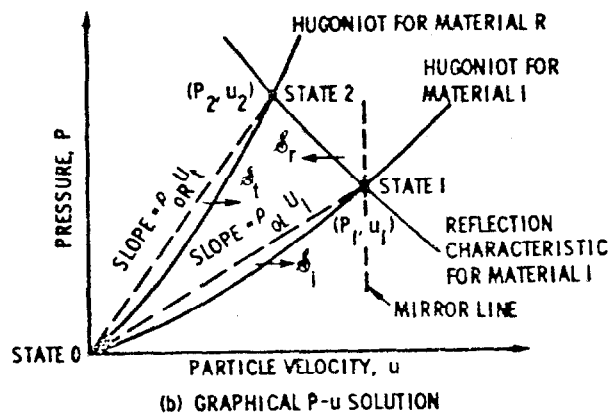
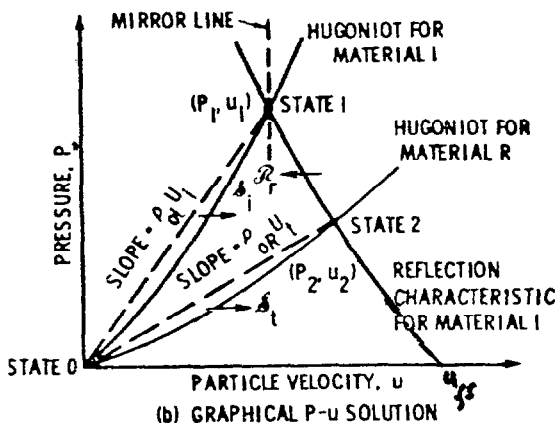
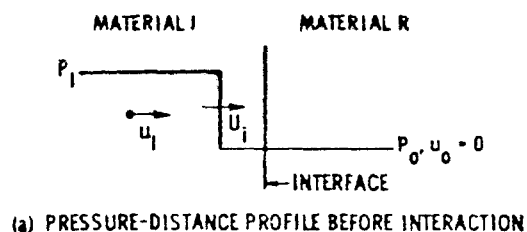
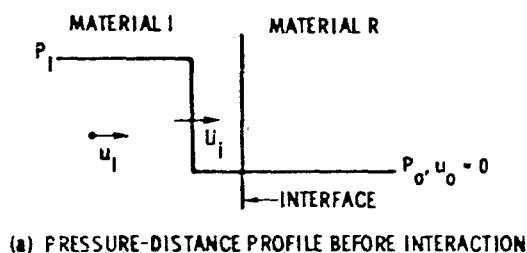

Fig 1 Transmission of a plane shock wave into a material of lower impedance

Fig 2 Transmission of a plane shock wave into a material of higher impedance

below, this is not a satisfactory method of describing shock properties. Much of the recent literature characterizes shocks by their peak pressure P , which is a more satisfactory approach than that of the early studies. An important factor not generally considered until comparatively recently is the duration of the shock. In many of the studies, input shock were not

wide "square waves", ie, the pressure of the shock decayed rapidly from its peak value at the shock front. Since the primary action of the input shock is to induce chemical reaction in the test expl, it is intuitively obvious that shock duration can be an important parameter in its ability to initiate the test expl

In many shock sensitivity studies, input shock

characteristics were determined only in the inert barrier. Examination of Figs 1 & 2 clearly shows that shock characteristics change as the shock passes from one material into a different material. Since these studies addressed the shock sensitivity of expls, the pertinent shock parameters are those in the tested expl, and not those in the barrier thru which the shock enters the expl. However, further examination of Figs 1 & 2 reveals that shock parameters in one medium can be used to determine shock parameters in another medium if the Hugoniot of both media are known

As an example, suppose P_1 (in Fig 2) represents the shock pressure in the inert barrier at the boundary between the barrier and the test expl. If the Hugoniot curve of the barrier is the lower curve in Fig 2, the shock about to enter the expl is characterized by P_1, u_1 . Now if the upper curve in Fig 2 represents the test expl, its intersection (at P_2, u_2) with the mirror-image of the lower curve drawn thru the point P_1, u_1 (as shown in Fig 2) then gives the shock state in the expl at its boundary with the barrier. It is not necessary to know the complete Hugoniot curve of the expl to obtain the shock state in the expl at the barrier/expl boundary. If the shock velocity U_t in the expl at its boundary with the barrier is measured, then the intersection of the reflected shock characteristic (as in the example above) with the *Rayleigh* line of slope $\rho_{0R} U_t$ (upper dashed line in Fig 2) gives the shock state in the expl at the barrier/expl boundary

Perusal of Figs 1 & 2 shows why the early shock sensitivity studies that measured only U_i were inadequate, since they provide no information as to the point on the line of slope $\rho_{0i} U_i$ about which the "mirror line" should be drawn. Thus the shock state in the expl remains unknown even if U_t is determined. Knowing U_i, U_t , the initial densities of both media and either P_1 or u_1 , one can obtain approx values of P_2, u_2 by reflecting a line of slope $\rho_{0i} U_i$ thru a point determined by either P_1 or u_1 on the *Rayleigh* line of the incident shock. The reason that this procedure gives only approximate values is that $P-u$ plots are curved and not linear

Some additional information about interpretation of shock sensitivity expts can be gleaned from study of qualitative P vs u curves such as

those in Figs 1 & 2. In shock sensitivity expts it is common practice to attach a metal witness plate to the explosive sample. Most metals have a higher shock impedance (ρU) than the expl. Thus, in accordance with Fig 2, interaction of the incident shock (in the expl) with the witness plate can send a reflected shock back into the expl. This can affect the initiation of the expl, since initiation generally occurs after some time delay after the input shock enters the expl and some distance into the expl from the barrier/expl boundary. Conversely, if the incident shock enters a medium of lower shock impedance (eg, air) as it exits from the test expl, a rarefaction is sent back into the expl. Such a rarefaction can quench incipient initiation of the expl. Rarefaction and reflected shocks can also arise at the periphery of the expl sample. Peripheral rarefactions in a "thin" expl test sample can prevent initiation. Conversely, metal confinement of the sample can generate reflected shocks which complicate interpretation of test results

In recent years, "flyer plate" shock sensitivity tests have begun to be used extensively. Basically these tests consist of propelling a thin plate against the expl sample. The variables in this test are plate velocity, plate material and plate thickness. The shock phenomena involved in the flyer plate expts are sketched in Fig 1. The plate velocity at impact is u_{fs} , the so-called free surface velocity. The intersection of the reflected characteristics of the shock Hugoniot of the plate material (drawn upwards from u_{fs}) with the $P-u$ curve of the expl then gives the shock state in the expl at the impacted expl surface (P_2, u_2 in the example)

The advantage of this flyer plate method is that shock duration τ_s can be controlled by varying plate thickness, namely $\tau_s \approx 2h/U_s$, where h is plate thickness and U_s is the shock velocity in the plate

We will postpone consideration of the effects of shock duration on shock sensitivity until we have described shock sensitivity tests (Section III) and take up this subject in Section IV

III Experimental Methods

Basically the determination of the shock sensitivity of an expl consists of subjecting the test expl to a controlled shock and observing the

behavior of the shocked sample. There are a variety of methods of doing this. The most common shock sensitivity tests are described below:

A. Gap Test

Probably the most frequently used shock sensitivity test is the so-called *gap test*, in which the shock generated by a standard donor is attenuated in an inert barrier before it enters the test expl (acceptor). Shock strength is varied by varying the thickness of the inert barrier, and results of the test are gaged by terminal observation of the effects of the acceptor on the witness plate or block on which it is placed

A test assembly used in many studies at NOL and elsewhere is shown in Fig 3 (taken from Ref 16). In this illustration the acceptor is a propint

A miniaturized version of the gap test, also developed at NOL and called SSGT (small scale gap test) is shown in Fig 4. Note the heavily confined donor and acceptor

For semi-quantitative data, results of both these tests can be simply reported as thickness

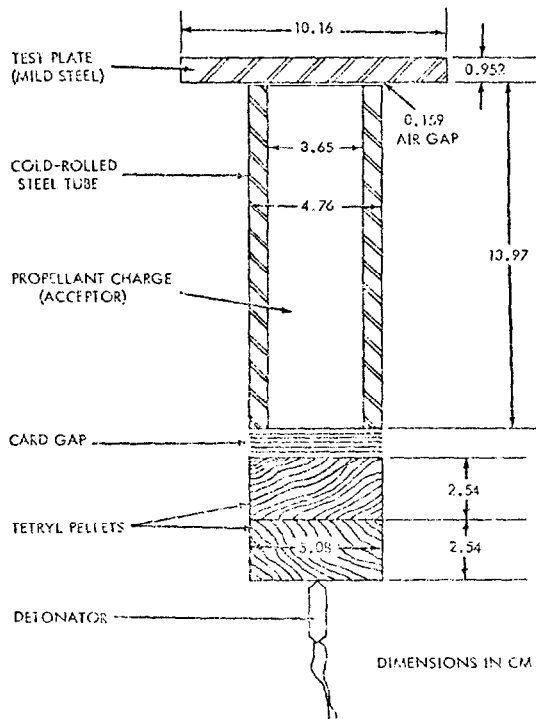

Fig 3 Charge Assembly and Dimensions for NOL Standardized Gap Test

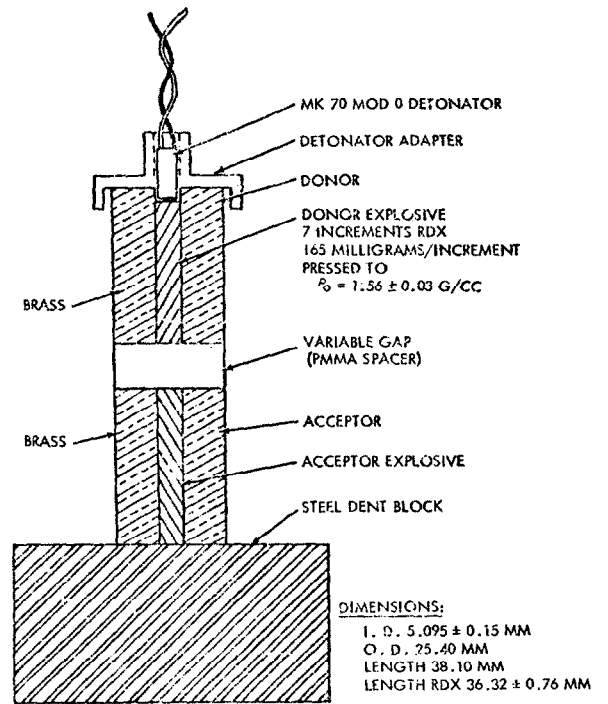

Fig 4 The Complete SSGT Setup

of inert barrier (gap) for a pre-determined "go-no-go" criterion. Almost universally this criterion is the 50% threshold, ie, the barrier thickness at which 1/2 of the trials are shots ("go's") and 1/2 of the trials are failures ("no-go's"). The Bruceton "up-and-down" method (see Vol 7, 136-37) is generally used to concentrate measurements near the threshold. In any given test set-up, results are usually very reproducible

To put gap test results on a more absolute basis (so that comparisons can hopefully be made between various forms of the gap test as well as with other shock sensitivity tests) it is necessary to calibrate the donor-gap system so that shock strengths are known as a function of barrier thickness. Details of calibration procedures are found in Refs 4 & 20a. If the shock Hugoniot of the unreacted test expl is known, the input shock in the test sample at the sample/barrier interface can be determined as discussed in Section II (Figs 1 & 2)

The writer (Refs 20a & 32) adapted a gap test used at LASL to the test scheme shown in Fig 5. This "instrumented gap test" has the ad-

vantage of providing data not only for the determination of the 50% threshold, but, as will be shown later, information on run-up distance to detonation in the test sample. Another desirable feature of this system is the use of a photocell to monitor the shock (or detonation) emerging from the acceptor and entering a thin air gap,

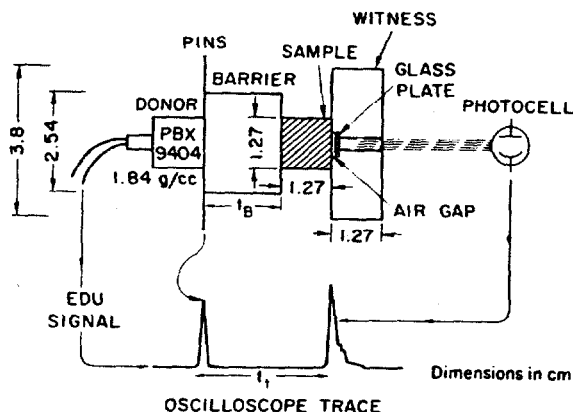

Fig 5 Schematic Cross Section of the Gap Test

as shown in Fig 5. This shock, if sufficiently strong, generates a very bright flash of light in the air gap. In a "no-go" test the emerging shock produces little or no air flash. The start of this light pulse determines the time at which a shock or detonation exits from the test sample. The amplitude of the light pulse helps to determine whether the sample has indeed detonated. An additional detonation criterion is of course provided by a dent in the witness plate

B. Wedge Shots

This technique was developed at LASL and has been widely used elsewhere. It is illustrated schematically in Fig 6 (taken from Ref 4). A plane-wave lens initiates a plane detonation in a Baratol "donor" and the shock from the donor is attenuated in a metal barrier ("driver") before it enters the bottom of a wedge-shaped test sample. The slanted face of the wedge is covered by a light-reflecting layer which reflects the light from an argon flash bomb into a streak camera. As the shock moves up the wedge it cuts off the light reflection, thus producing camera records such as the one shown schematically in Fig 7

As seen in Fig 7, a wedge shot record provides direct information on the velocity of the

input shock and the time and distance at which transition to detonation takes place

An actual streak camera record and its relationship to wedge geometry is shown in Fig 8 (Refs 20a & 32). The wire image and its displacement provide a measure of the free surface velocity of the brass "driver". From this measurement, the known Hugoniot of the driver, the initial shock velocity in the test expl and its unshocked density, one can obtain the input pressure and particle velocity in the test expl at the expl/barrier interface by methods described in Section II. In our studies (Refs 20a & 32) the wedges were sufficiently reflective so that a reflecting film on the wedge was not necessary. Rarefactions from wedge free surfaces can complicate interpretation of wedge shot records. Proper choice of wedge angles can minimize this problem. The choice of wedge angle is addressed in Appendix D of Ref 20a

In summary, wedge shots, though expensive and time-consuming, will provide direct data on the shock input into the test expl and a distance-time record of the shock and its transition to detonation in the test expl. As an added bonus each wedge shot also gives one point (P & u) on the shock Hugoniot of the acceptor expl

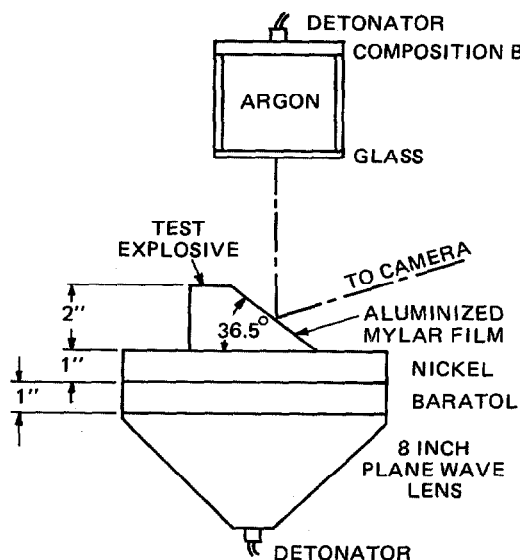

Fig 6 Schematic Diagram of the LASL Wedge Slant System (Ref 4)

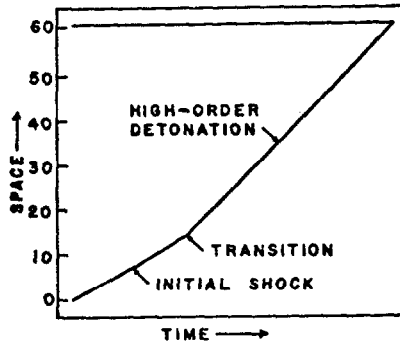

Fig 7 Schematic Representation of a Streak Camera Record of a Wedge Shot (Ref 4)

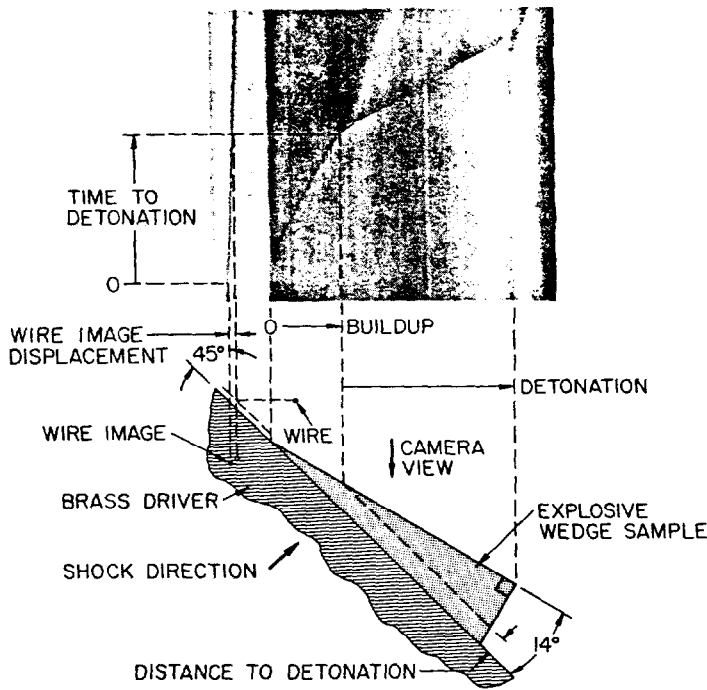

Fig 8 Streak Camera Record from Wedge Shot. Schematic drawing shows relationship between wedge geometry and camera record

C. Flyer Plate Tests

In recent years the flyer plate technique of determining shock sensitivity has become very popular (eg, Refs 11, 30, 37, 51, 55, 59, 60, 61, 64, 65 & 66). It has the distinct advantage of delivering a plane-wave rectangular pulse of known duration to the test expl. Also the amplitude and duration of these shocks can be varied over a wide range

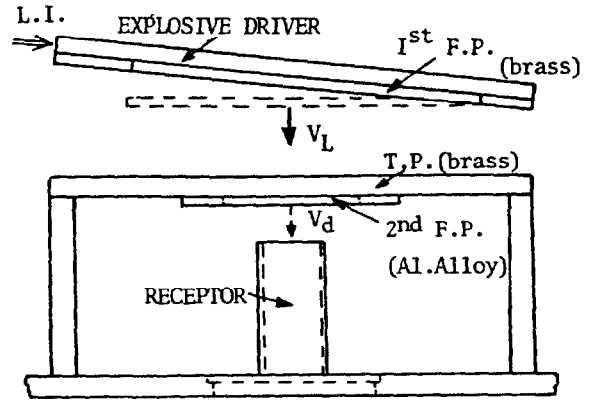

Fig 9 Two Stages Set-up for the Study of Granular Explosive
 F.P. = flyer plate
 T.P. = momentum transfer plate
 L.I. = line initiator

The method of propelling flyer plates by donor expls is illustrated in Fig 9 (Ref 55). The system shown uses a two-stage flyer plate arrangement to obtain "low" impact velocities

Fig 10 (Ref 55) shows the principle of generating rectangular pulses with one-stage flyer plates. The diagram at left shows the shock reverberations in the flyer plate and the diagrams at right show the P-u history and pulse shape respectively

Fig 11 (Ref 55) gives the P-u histories for one-stage brass or Al alloy flyers and for the two-stage brass-Al alloy combination

Most of the very recent studies used "gas guns" to propel flyer plates. An example of a gas gun is shown schematically in Fig 12 (Ref 59). In this illustration the impacting surface of a flyer plate is in a quartz pressure transducer

Wackerle et al (Ref 51) combined the gas gun-flyer technique with wedge-type acceptors as shown in Fig 13 and the resulting streak camera record in Fig 14

A flyer plate technique applicable to "gap tests" is used at Lawrence Livermore Laboratory. In this technique metal foils "exploded" by the high energy discharge of a capacitor bank are used to propel plastic flyers. It is illustrated in Fig 15 (Ref 57)

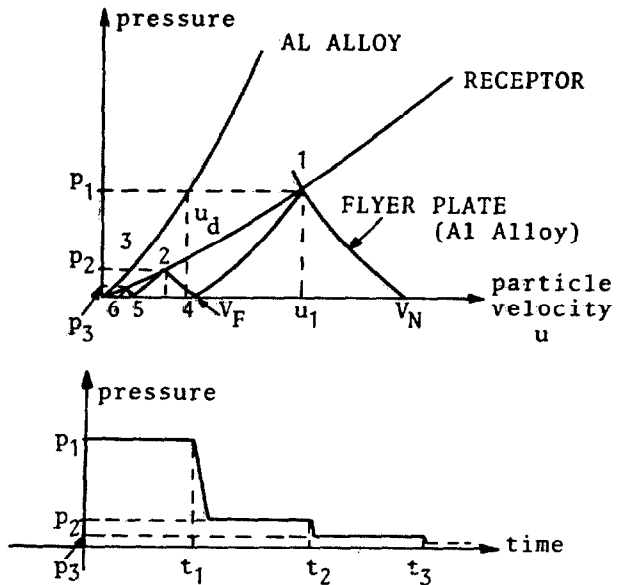
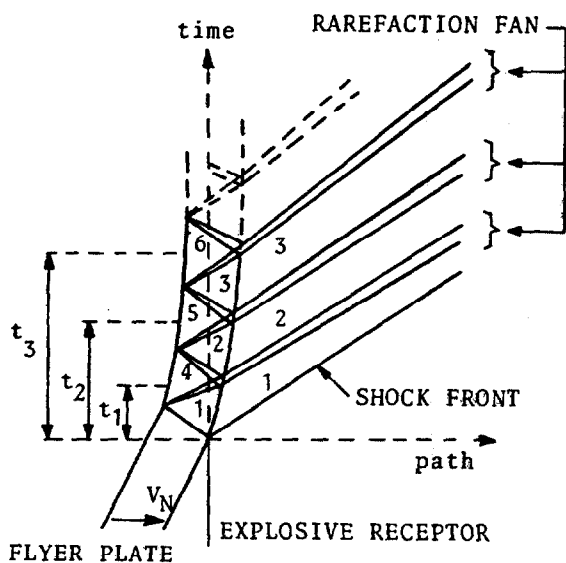

Fig 10 Principle of Generation of Rectangular Pressure Pulses

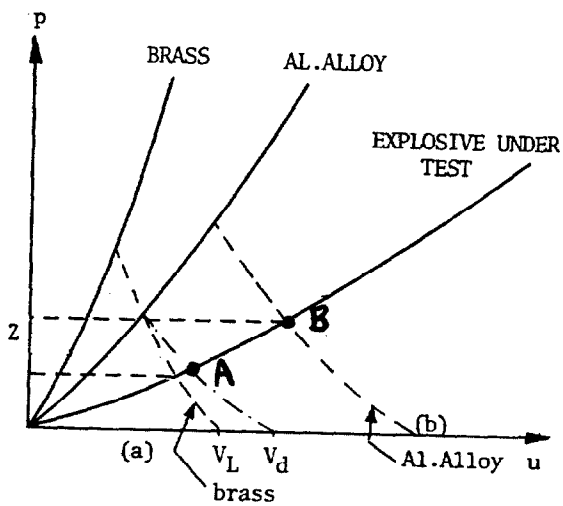

Fig 11 Principle of the Two-Stages Set-Up
Z = Zone of pressures to be explored

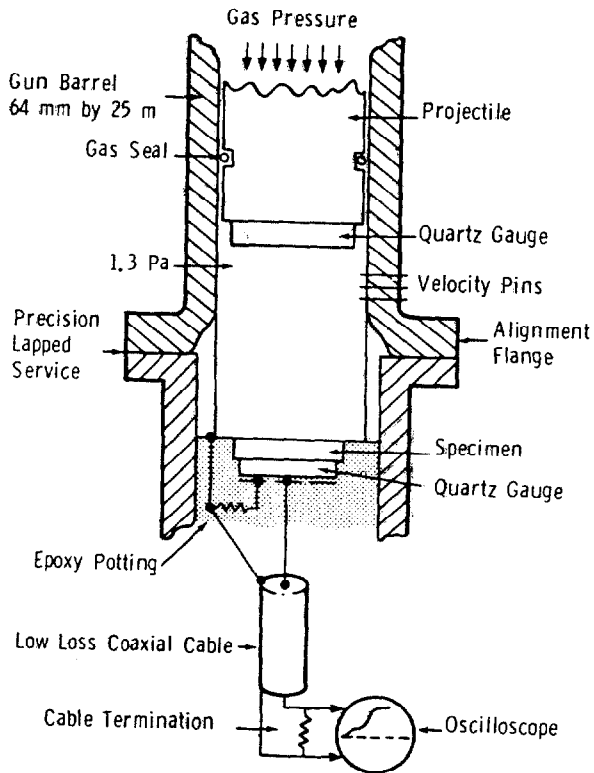

Fig 12 Schematic Diagram of a Gas Gun-Flyer Plate System

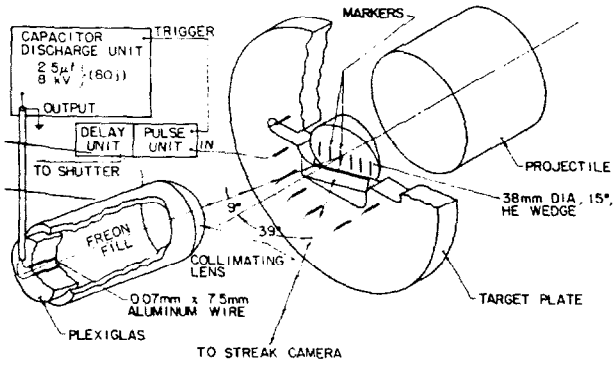

Fig 13 Explosive Wedge Experiment

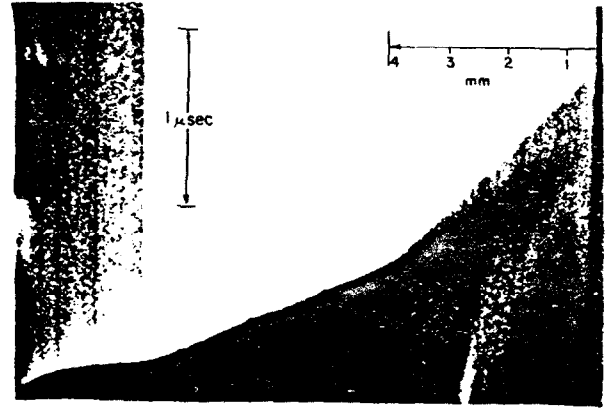

Fig 14 Typical streak-camera record from an explosive wedge experiment. Time increases downward and the upper scale shows the distance of the shock from the impact face. The slope of the trace at right is proportional to the shock velocity during buildup to detonation

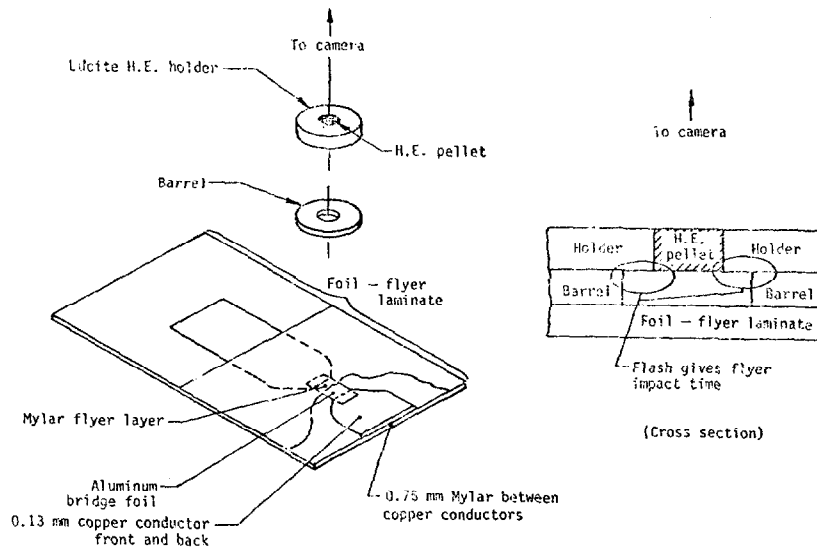

Fig 15 Schematic diagram of the system used for initiation studies. The foil-flyer laminate is connected to an appropriate capacitor bank and the barrel and HE holder are clamped directly over the foil. When the foil explodes it drives the flyer down the barrel to impact the sample. The cross-sectional view shows how the flash produced by flyer impact can be viewed around the sample

D. Laser Beam Initiation

Focused pulsed laser beams are absorbed in very thin layers of most materials (particularly metals) and can thus generate high temps very rapidly in very narrow zones. This process will readily produce powerful shocks in the absorbing material. A good summary of the shock initiation of expls with shocks generated by Q-switched lasers is given by Yang & Menichelli (Ref 56). Expls studied were PETN, RDX, Tetryl and HNS. Two modes of shock generation were used: 1) Generation of shocks in a thin metal film in contact with the test expl; 2) Direct absorption of the laser energy by the expl and consequent in situ shock generation

Typical conditions of mode 1) expts are: Use of a Q-switched laser of 25 nanosec duration and max energy of 4 joules in a 1.43cm diam beam; Al film about 1000Å thick on the expl side of the window of the expl container; expl columns 1 to 4mm diam and at least 20mm long

For PETN or RDX of less than 40 micron particle size, initiations were obtained within 0.5 microsec of pulse exposure and detonation (either steady or overdriven) started very close to the metal film. Approx fluence thresholds are as follows: PETN at 1.58g/cc, 35.6 J/cm²; RDX at 1.18g/cc, 45.3 J/cm²; and RDX at 1.52g/cc, 127.9 J/cm². It was found that for essentially instantaneous initiation, fluence threshold did not vary with laser pulse duration. Indeed what is observed in these expts is either essentially instantaneous detonation or burning. No build-up of the shock and run-up to detonation (such as is the usual case in conventional shock sensitivity expts) is observed. No steady detonation was observed with "coarse" (> 100 micron) PETN or RDX. Fine RDX at 1.64g/cc also failed to detonate. Low density fine HNS or Dipam could not be initiated in these expts. Low density fine Tetryl exhibited a curious "super detonation" which needs confirmation and further study

Results of the direct initiation of expls by laser beams are much less reproducible than those described above. This mode is presumably a combination of shock initiation and direct heating of the expl by the plasma produced within it by the absorbed laser energy. The latter will be strongly dependent on crystal imperfections and impurities. Consequently the direct initiation of expls by lasers is not a good

method of studying shock sensitivity

E. Miscellaneous Methods

Bartels (Ref 39) has described a gap-test which he claims is applicable to measuring the shock sensitivity of expls as well as potentially explodable pyrot compns. This test differs from the NOL SSGT (Fig 4) in that confinement of the acceptor is much reduced and w is used as the inert barrier. Instead of a witness plate Bartels used an Al "witness-rod"

Avrami et al (Ref 46) used an electrode beam app (Physics International Mod 738 Pulserad) to rapidly heat a slab of Al. The shock thus generated by rapid energy deposition was transmitted into pressed pellets of KDNBF (K dinitrobenzofuroxan). With shocks of about 0.2 microsec duration and a pellet thickness of 0.25 inch the initiation threshold measured was about 18 kbar

F. Threshold Criteria

Characterization of the input shock state in the expl has been discussed in Section II as well as in this Section. In principle the input shock for a pre-determined initiation threshold (commonly the 50% value) can be characterized for sustained shocks by: 1) the initial shock velocity in the test expl; 2) pressure in the expl at its shocked face; and 3) particle velocity in the expl at its shocked face

Initial shock velocity is a very poor method of characterizing input shock. This becomes obvious upon examination of Fig 11. Let points A & B in Fig 11 represent initiation thresholds for two different expls, both at a density ρ_0 . Points A & B in this diagram are well separated in both P & u. Thus no extraordinary exptl accuracy is required to distinguish states A & B in terms of either P or u. The slopes of the Rayleigh lines (the lines connecting A or B to the origin), however, are almost equal. Since these slopes are equal to $\rho_0 U$, extreme exptl accuracy is necessary to characterize thresholds in terms of U, the initial shock velocities in the test expls

It has been common practice to characterize initiation thresholds in terms of input pressure and in most of our subsequent discussion we will continue to use this criterion. As will be shown later, however, there is some merit to doing this in terms of a critical particle velocity u rather than pressure

Thus far we have tacitly ignored the effect of shock duration on its capability of initiating detonation. For "sustained" shocks (> 1 microsecond duration) this appears permissible since initiation thresholds are only mildly influenced by shock duration of "sustained" shocks. We shall examine the effects of shock duration of sub-microsecond duration shocks in subsequent sections

IV Factors that Control Shock Sensitivity

In the 5th Detonation Symposium, D. Price presented a paper entitled "Shock Sensitivity, a Property of Many Aspects" (Ref 31). These "many aspects" are evident even when shock sensitivity is examined strictly from a phenomenological point of view. In this section we will examine the main variables that control shock sensitivity and give examples of the effects of these variables on shock sensitivity. The strong influence of homogeneity of an expl on its shock sensitivity will be discussed in Sections VI and VII

A. Inherent Nature of the Explosive

It seems reasonable to expect that expls that are "sensitive" (eg, sensitive to impact, friction, sparks, etc) will also be sensitive to shock. Generally this expectation is borne out by experience, at least in a qualitative way. Under comparable conditions PETN is certainly more shock-sensitive than TNT, and so on. An example of the parallelism in impact and shock sensitivity of four common expls is shown in the tabulation below. The comparisons are obviously qualitative in that the expls are ranked in descending order of sensitivity. It must be emphasized that reversals in sensitivity ranking can occur if comparisons are made of sensitivity data obtained under non-comparable test conditions

Explosive	Impact Sensitivity Rating	Shock Sensitivity Rating
PETN	First	First
RDX	Second	Second
Tetryl	Third	Third
TNT	Fourth (a)	Fourth (a)

(a) Much less sensitive than Tetryl

To date there is no unequivocal way of attributing the sensitivity of an expl to its chemical

nature and its thermodynamic or kinetic properties

B. Packing Density

Without exception the shock sensitivity of any expl increases as its packing density is decreased. At one extreme we have expl single crystals (ie, expls at their theoretical maximum density, TMD) and at the other extreme expl crystals carefully poured into a container without any tamping or vibration. As an illustration, single crystal PETN requires shocks of the order of 115kb for its initiation (Ref 1), whereas poured PETN at about 1 g/cc requires only 2-3kb shocks (Ref 5). As an additional example consider the TNT data of Price and Liddiard (Ref 16) shown in Table 1

Clearly packing density exerts a pronounced influence on shock sensitivity if shock sensitivity is gaged by input shock amplitude

C. Particle Size

The shock sensitivity threshold for coarse particle size expls is generally lower than for finer particles of these expls, provided the comparison is made between coarse and fine particles at the same density. This somewhat unexpected result was first reported for Tetryl by Seely (Ref 6a). Subsequently it was observed by the writer for RDX (Ref 32), by Scott for PETN, RDX & Tetryl (Ref 35), and for PETN by Dinegar et al (Ref 40)

Table 1
Shock Sensitivity of TNT according to Ref 16

Packing Density g/cc	Shock Initiation Threshold* (kb)
1.07	8.9
1.25	12.3
1.42	15.5
1.49	16.2
1.60**	20.8

*Obtained in the test method shown in Fig 3; pressures shown are pressures in the inert barrier at the barrier/acceptor interface

**Single crystal density is 1.63g/cc

The writer's results for RDX at 1.54g/cc, obtained in the test system shown in Fig 5, were as follows (threshold values are shock amplitudes in the RDX at the inert barrier/RDX interface): 5 micron particle size (5800cm²/g avg specific surface) - 15.0kb threshold

60 micron particle size (550cm²/g avg specific surface) – 9.0kb threshold

Scott used a test system shown in Fig 4, and his threshold values are pressures in the inert barrier at the barrier/expl interface. Samples of his results are as follows:

	Threshold (kb)
1.52g/cc RDX 60/80 Std screen particle size	7
1.52g/cc RDX thru 325 screen particle size	10
1.51g/cc PETN 120/200 Std screen particle size	6
1.51g/cc PETN thru 325 screen particle size	7.5

Price et al (Ref 38) showed that AP (ammonium perchlorate) behaves in a similar fashion in that compacts of 25 micron AP particles are considerably more shock-sensitive than compacts of 7 micron particles (See Fig 19)

These data show that particle size exerts a small but consistent effect on shock sensitivity

D. Shock Duration

Since initiation of detonation is generally accepted to be a thermal process it is to be expected that shock sensitivity will be influenced by the time of application (duration) of the initiating shock. This expectation is amply

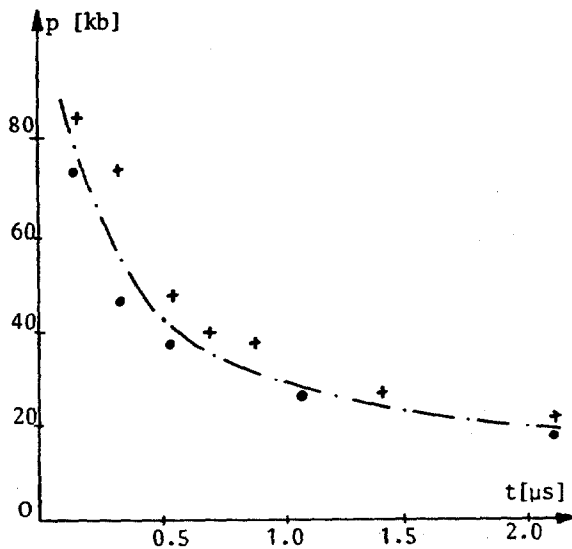

Fig 16 Sensitivity of Composition B3 (60/40)
+ detonation • no detonation

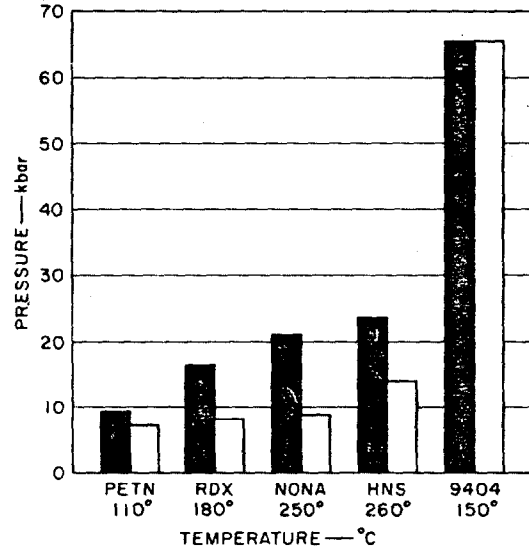

Fig 17 Shock Sensitivity of Five Explosives
50% thresholds are given as pressures in the expl at the barrier/expl interface. Dark-colored bars are for 25°C and light-colored bars are for the temps shown

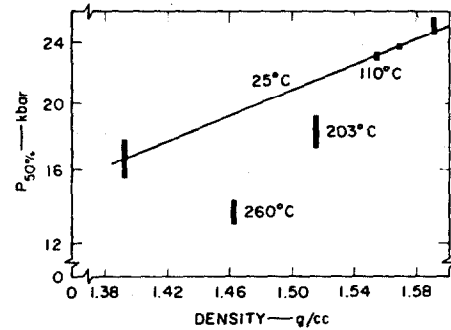

Fig 18 Effect of Initial Density and Initial Temperature on the 50% Threshold of HNS

confirmed by a number of exptl studies such as Refs 11, 23, 29, 30, 31, 50, 52, 54a & 55. The general nature of this effect is illustrated in Fig 16 taken from Ref 55. The usual observation, as shown in Fig 16, is that threshold pressure varies strongly with short duration shocks and much more mildly for "long" duration shocks. Indeed threshold pressure appears to be essentially independent of shock duration at shock durations of two microsec or longer

E. Ambient Temperature

There appears to be general agreement that pre-heating an expl makes it more sensitive to shock, and conversely cooling an expl makes it less sensitive to shock (Refs 20a, 21a, 32, 34a & 53). The writer (Refs 20a & 32) established that this effect holds in gap-test as well as plane-wave geometry. His results for gap-test geometry (see Fig 5) are summarized in Fig 17. The apparent lack of pre-heating sensitization in PB 9404 was found to be due to an increased velocity of side-rarefactions in the hot expl. Thus the sensitization of pre-heating is counterbalanced by the increased quenching action of side-rarefactions

It is legitimate to inquire whether sensitization by pre-heating is an intrinsic effect or whether it is due to a decrease in expl density (expansion) as a result of pre-heating. The data of Fig 18, from Ref 32, clearly show that the effect of pre-heating cannot be attributed solely to a decrease in packing density of the pre-heated expl. Here the line is drawn thru the P_{50%}-density data at 25°. For HNS pre-heated to 110°, the sensitization effect may be solely due to expansion and a decrease in density. However, at 203° and especially at 260° sensitization is clearly greater than that produced by a decrease in density

F. Inert Coatings

Based on results obtained in impact tests, it might be anticipated that coating or mixing an expl with an inert wax or plastic would decrease its shock sensitivity. Exptl evidence generally supports this point of view, but there is at least one outstanding exception. Eadie (Ref 12) compared the shock sensitivity of HMX with and without beeswax coatings. He found that coatings ranging from 1 to 10% progressively desensitized HMX to shock even though the packing density of the highest-coated material was appreciably less than that of pure HMX (this decrease in density, as shown in Subsection B, should have resulted in sensitization rather than desensitization). From the run-up distance to detonation data for various input plane-wave shocks obtained by Lindstrom (Ref 17) for 94/6 RDX/Exon-plastic at 1.6g/cc, the shock amplitude threshold can be estimated to be about 10–11kbar. This is to be compared with about 6.5kb for the NOL LSGT data (see Fig 3) for RDX at 1.6g/cc, and about 10.5kb for the NOL SSGT data (see Fig 4) quoted in

Ref 16.* Since, as will be shown below, plane-wave data for a given expl should provide a lower threshold than either the LSGT or SSGT, the above comparison strongly suggests that addition of Exon decreases the shock sensitivity of RDX

The known exception to desensitization by admixed inert material is AP. Price et al (Ref 38) obtained the results given in Fig 19, which clearly show that addition of carnauba wax actually sensitizes AP to shock. The probable explanation for this effect is complex and the interested reader should consult the original article. Incidentally this graph also shows that coarse AP is more shock-sensitive than fine AP

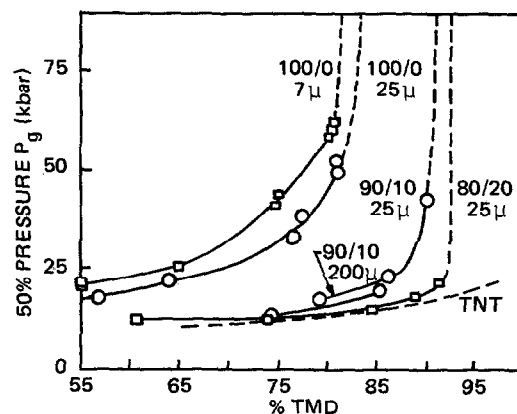

Fig 19 Shock Sensitivity Curves for Waxed and Unwaxed Ammonium Perchlorate and for TNT. Vertical lines at top of graph mark lowest percentage of TMD at which a sub-detonation reaction was observed

G. Interstitial Gas

This effect has been investigated by Chick (Ref 9), Marshall (Ref 34), Dinegar et al (Refs 40 & 43) and Tabor et al (Refs 41 & 42). The results of Chick and Dinegar are in general agreement, namely:

- Most interstitial gases desensitize low density expl compacts
- Desensitization is more pronounced at high gas pressures
- Polyatomic gases desensitize more than monatomic or diatomic gases

*Threshold values given in Ref 16 are for shock pressures in the barrier at the barrier/acceptor interface. These were converted by the writer into shock pressures in the acceptor at the barrier/acceptor interface by the methods sketched in Figs 1 & 2

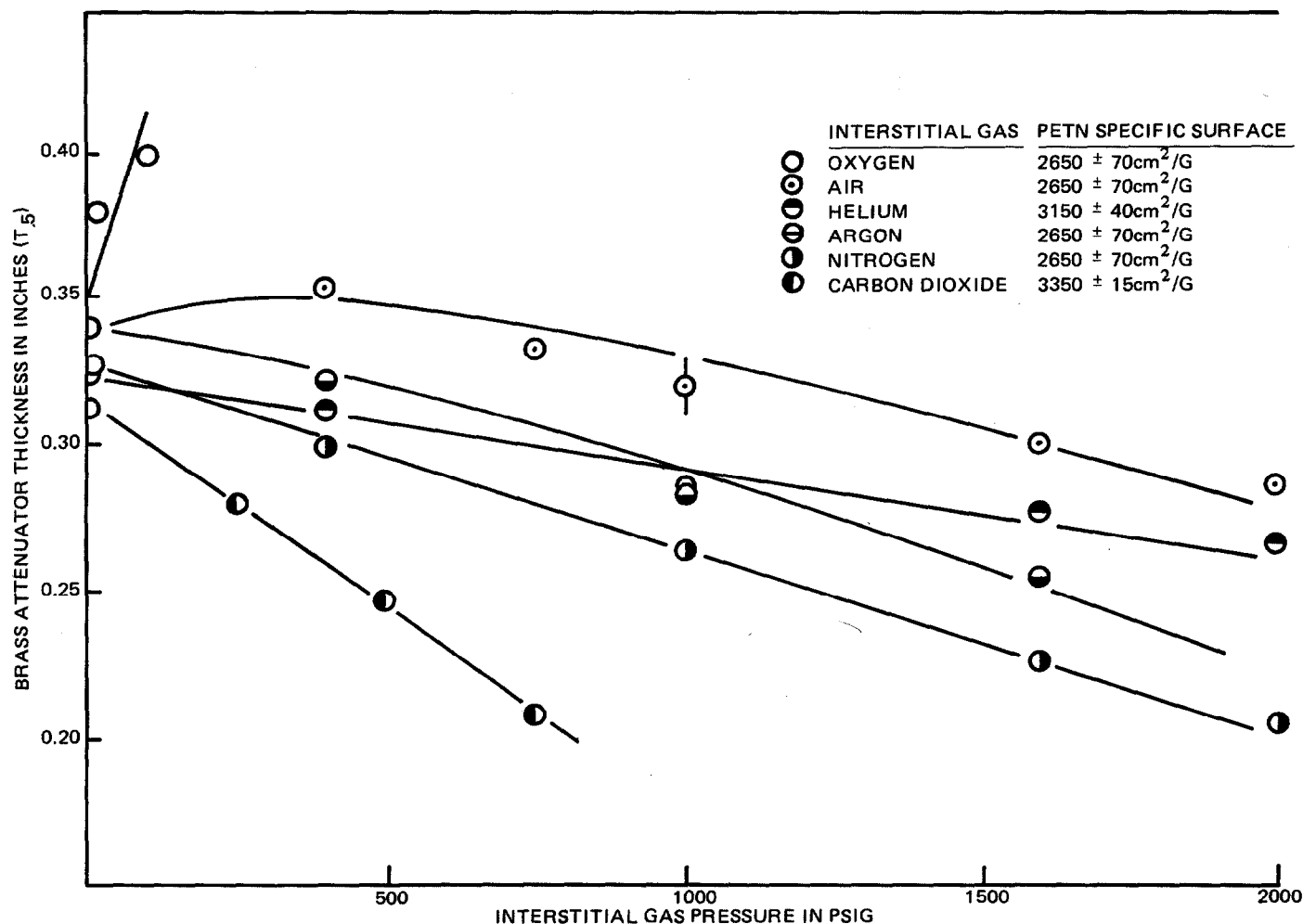

Fig 20 Effect of Interstitial Gas Pressure on the Small-Scale Gap-Test Sensitivity of Low Specific Surface PETN

These generalizations are illustrated in Fig 20 (from Ref 40), which also shows that O₂ and mixts of O₂ and N₂ sensitize PETN, while all other gases tested desensitize it to shock. Note that shock amplitude in Fig 20 is given in terms of barrier thickness, ie, the thicker the barrier the more shock-sensitive the PETN-gas combination

Marshall extended the expts of Chick to confirm Chick's major conclusions. However he also determined that run-up times to detonation did not depend on the nature or pressure of the interstitial gas

Somewhat at odds with all of the above results are the findings of Tabor et al. They claim that rapid collapse of gas bubbles is important

in the initiation of AgN₃ by weak shocks. Bubbles of air, Ar, He and butane were used in their expts but the only statement as to results (in Refs 41 & 42) is that air bubbles of about 50 microns can cause initiation of AgN₃. The data of Dremin & Shvedov (Ref 52) are apparently in even greater disagreement with those above. Their results can be interpreted to mean that air, Ar & CO₂ at pressures of 0.05–12 atm have little or no effect on the shock sensitivity of low density TNT, Tetryl or RDX

H. Shock Geometry

Shock initiation data are most amenable to simple interpretation when the initiating shock is plane-wave. Unfortunately, until the recent advent of flyer-plate techniques, plane-wave

Table 2
Effect of Shock Geometry on Shock Sensitivity
 (IG = instrumented gap test; PW = plane wave wedge shots)

<u>Explosive</u>	<u>Density (g/cc)</u>	<u>Test Designation*</u>	<u>Shock Initiation Threshold (kbar)</u>	<u>Ref</u>
RDX	1.64	LSGT	6.3**	16
RDX	1.63	SSGT	10.5**	16
RDX	1.64	IG	15.2	32
RDX/Exon-94/6	1.6	PW	10-11	17
RDX	1.53	LSGT	5.3**	16
RDX	1.56	SSGT	8.0**	16
RDX	1.54	IG	8.8 (a)	32
Tetryl	1.64	LSGT	12 **	16
Tetryl	1.66	SSGT	17 **	16
Tetryl	1.65	PW	~ 14	24
Tetryl	1.49	LSGT	6.5**	16
Tetryl	1.50	SSGT	8.5**	16
Tetryl	1.50	PW	~ 5.5	24
Tetryl	1.43	LSGT	6.0**	16
Tetryl	1.42	SSGT	7.0**	24
Tetryl	1.40	PW	4.5	24

*See Figs 3, 4, 5 & 6 for test arrangements

**Given as shock pressure in the barrier at the barrier/expl interface and converted by the writer into shock pressure in the expl at the barrier/explosive interface using the expl Hugoniot data of Refs 32 & 24
 (a)Probably somewhat coarser particles than those in the corresponding LSGT and SSGT data

shocks required elaborate donor systems so that much of the shock initiation literature is based on non-planar shock. For non-planar shocks, the effects of side-rarefactions are magnified and there is no unequivocal means of defining shock duration. Nevertheless non-planar gap tests can and do furnish much useful information. The deleterious effects of non-planarity and rarefactions can be mitigated by increasing the donor and acceptor size. Confinement of the acceptor can reduce side rarefactions but can introduce complications due to shock reflection from the confining medium. Several of the effects described above are illustrated in Table 2

Note that, as expected, plane wave wedge shots give the lowest shock initiation "thresholds" (except for 1.65g/cc Tetryl, where some of the data may be in error or else particle sizes are not comparable). In reality wedge shots do not provide threshold data directly. The values quoted in Table 2 are obtained from plots of

run-up distance to detonation vs input shock pressure. The threshold is taken as the pressure at which this plot becomes asymptotically steep. The mitigation of side-rarefactions is illustrated by the lower thresholds in tests of large diameter and/or confined acceptors

V Shock Sensitivity Data

In recent years a large amount of shock sensitivity data has appeared in the expls literature. To present all these data would not only be a Herculean labor but would make this article entirely unwieldy. What will be done is to give references to the most important published results with keyword description of the type of test used and the major results obtained (Table 3). Incidentally, recent Encyclopedia articles on individual expls (eg, *PETN* & *RDX*) describe the shock sensitivity of these expls in considerable detail

Table 3
Literature Shock Sensitivity Data

Explosive	Density (g/cc)	Test Arrangement*	Run-up Data	Hugoniot Data	Ref
AP	1.0-1.6	LSGT	—	—	38
AP	1.00	PW	x	x	10
Comp B	1.7	PW	x	x	13
Comp B	1.70	Modified LSGT	x	—	8
Comp B	1.70	PW	x	—	4
Comp B	1.70	LSGT	—	—	27
Comp B	1.72	PW	x	—	30
Comp B	1.72	PW	x	—	11a
Comp C-3	1.60	LSGT & SSGT	—	—	16
Cyclotol 50/50	1.69	PW	—	—	6
DATB	1.21-1.76	LSGT & SSGT	—	—	16
DATB	1.23-1.78	SSGT	—	x	47
1,2 DP (a)	liq	PW	x	x	33
2,2 DP (b)	liq	PW	x	x	33
1,2 DB (c)	liq	PW	x	x	33
HNAB	1.53	IGT	x	—	20a
HNS	1.38-1.57	IGT & PW	x	x	32
HNS	1.01-1.71	PW	x	x	59
HNS	1.47-1.58	PW	x	x	58
Lead Azide	2.9-3.6	PW	x	x	62
LX-04	1.86	Modified LSGT	x	x	8
NG	liq	PW	—	x	20
NG	liq	PW	—	—	6
NM	liq	PW	x	x	3
NM	liq	PW	—	—	6
NM	liq	PW	—	—	14
NM	liq	PW	x	—	33
Nitroguanidine	0.95-1.64	LSGT & SSGT	—	—	16
Nitroguanidine	1.55	LSGT	—	—	27
Nona	1.60	IGT	x	x	32
PETN	1.36-1.77	SSGT	—	x	47
PETN	1.59	IGT	x	x	32
PETN	1.0	PW	x	—	11a
PETN	1.0	PW	x	x	5
PETN	Single Crystal	PW	—	x	1
PETN	Single Crystal	PW	x	—	3
PETN	1.36-1.68	SSGT	—	—	44
PETN	1.50	SSGT	—	—	35
PETN	1.60-1.72	PW	x	x	25
PETN	1.6-1.7	PW	x	x	45
PETN	1.75	PW	x	x	51
Pentolite	1.65	Modified LSGT	x	x	8

(continued)

Table 3 (continuation)

Explosive	Density (g/cc)	Test Arrangement*	Run-up Data	Hugoniot Data	Ref
PBX 9404	1.83	Modified LSGT	x	x	8
PBX 9404	1.84	IGT & PW	x	x	32
PBX 9404	1.83	PW	—	x	11a
PBX 9404	1.84	Flyer foil	x	x	11
PBX 9404	1.83	Flyer foil	x	—	30
PBX 9404	1.83	PW (d)	x	x	37
PBX 9404	1.83	PW	x	—	36
PBX 9404	1.83	Flyer foil	x	—	65
PBX 9404	1.84	Flyer foil	x	—	63
Propellants (Double Base)	1.76–1.80	PW	x	x	18
Propellants Powder N (?)	1.56	PW	—	—	6
RDX	1.74	PW	—	—	6
RDX	Single Crystal	PW	—	—	6
RDX	1.54–1.64	IGT	x	x	32
RDX	1.56–1.73	LSGT & SSGT	—	—	16
94/6–RDX/plastic	1.60	PW	x	x	17
TATB	1.52–1.89	LSGT & SSGT	—	—	16
TATB	1.52–1.89	SSGT	—	x	47
TATB	1.70–1.85	Flyer foil	x	—	60
Tetryl	1.30–1.70	PW	x	x	24
Tetryl	1.43–1.73	LSGT & SSGT	—	—	16
Tetryl	1.65	Modified LSGT	x	—	8
TNT	liq	PW	x	—	3
TNT	1.5 –1.63	PW	x	—	4
TNT	1.35–1.65	SSGT	—	x	47
TNT	1.62	Modified LSGT	x	—	8
TNT	1.07–1.65	LSGT & SSGT	—	—	16
TNT	1.30–1.55	Flyer foil	—	x	49
TNT	1.30–1.55	Flyer foil	x	—	50

*See notes of Table 2

(a) 1,2-bis(difluoramino) propane; (b) 2,2-bis (difluoramino) propane; (c) 1,2-bis (difluoramino) propane; (d) Impacting quartz gauge

VI Mechanism of Shock Initiation of Homogeneous Explosives

The classical view of the mechanism of shock initiation of homogenous expls, ably presented in Ref 3, has been discussed in some detail in Vol 7 under *Liquid Explosives*, L31-L to L32-R. Briefly stated this mechanism involves a thermal expln at or near the shock entry face

(here the expl has been shock-heated first and has had time to react), which in turn generates a shock which overtakes the input shock at some distance inside the expl column (because the thermal expln shock travels in a medium pre-compressed by the input shock), and develops into steady detonation shortly thereafter. According to Campbell et al (Ref 3) the above

mechanism applies not only to liquid expls but also to expl single crystals

A readily apparent differentiation between the shock sensitivity of homogenous and heterogenous expls is the much greater shock pressures required to initiate the former. Examples of these high pressures (not necessarily threshold pressure but probably close to threshold) are shown in Table 4

Table 4
Shock Sensitivity of Homogenous Explosives

Explosive	Shock Pressure (kbar)	Ref
NM	86	3
TNT (liq)	125	3
NG	110	quoted in 21
TNM	86	quoted in 21
RDX single crystal	170	quoted in 21
PETN single crystal	112	3

In recent years some studies have started to appear that contradict the classical mechanism. For example, Walker & Wasley (Ref 29a) found that Nitromethane (NM) could be initiated at pressures as low as 50kbar, and times to detonation did not follow Arrhenius kinetics. Very recently, Dremin (Ref 67) has made some interesting suggestions to explain the apparent failure of the classical theory. Unfortunately Dremin's ideas are very hard to follow because of language difficulties in his presentation. Dremin's explanation is based on the assumption that shock-initiation in homogenous expls (primarily liquids in his discussion) is *not homogenous* thruout the volume of the expl. There is exptl evidence to support this point of view, namely the fairly regular cellular structure of detonation luminescence or luminescence of expanding detonation products observed respectively in "insensitive" liq and solid expls. Dremin points out that the shocked expl is initially in a highly non-equilibrium state because of the rapidity with which transition occurs from the initial state to the highly compressed shocked state. In such a non-equilibrium state, some molecules will be much hotter than others. If, as expected, thermal decompn is relatively slow compared to shock-heating, some transfer of heat from these "super-

hot" molecules to other hot molecules may occur before reaction is complete. This creates a situation which may be considered as either an increase of the effective temp of the heated zone over that expected on the basis of homogenous shock-heating, or, conversely, an effective lowering of the activation energy of the decompn reaction. Obviously any increase in decompn rate will tend to counteract the reaction quenching action of rarefactions. It is the interaction between increased reaction rates at non-homogenous sites and rarefaction quenching that is believed to be the cause of the observed cellular structure of the detonations referred to above. The non-homogenous decompn of shocked homogenous expls also provides an explanation for the observed milder-than-expected dependence of the shock-sensitivity of homogenous expls on initial conditions. In particular, it may obviate various tour-de-force explanations that have been advanced in lieu of classical Arrhenius kinetics to explain the mild variation of time-to-expln with input pressure

VII Mechanism of Shock Initiation of Heterogenous Explosives

It is readily shown (Ref 32) that high upper limit estimates of the *uniform shock heating* of solid expls packed to 50–85% TMD amounts to only 100–200° for shocks known to initiate detonation. Clearly this shock initiation process must be highly heterogenous in that only selected regions (*hot spots*) can be raised to high enough temps to initiate decompn reactions which are completed within time frames (microsecs) that are typical of shock initiation phenomena. Although the necessity for invoking a hot spot mechanism for the shock initiation of pressed and cast expls has long been recognized, the processes by which these hot spots are created and how they interact to generate steady detonation are still undetermined

Further confirmation of the hot-spot nature of shock initiation of granular expls was obtained in some very interesting preliminary expts by Von Holle (Ref 66). He used time-resolved IR radiometry to monitor the brightness temp in 5–8mm thick charges of PBX 9404 impacted by gas-gun driven flyer plates to give "sustained" flat pressure pulses in the test samples. His main results are summarized in Fig 21

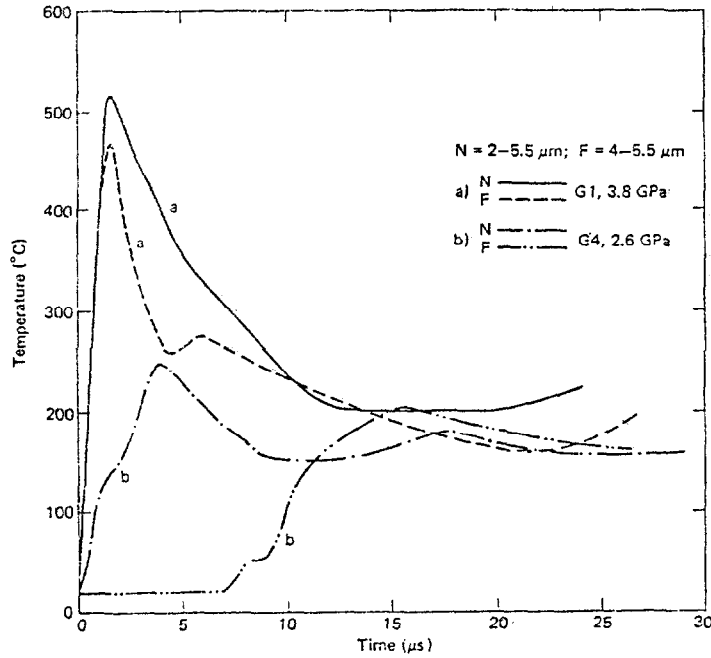

Fig 21 Blackbody Temperature - Time Plots
For Two Bare Charge Shots

Von Holle interprets these results as follows: "The explosive is initially very unevenly heated with areas of very high temperature (hot spots) arising from chemical energy release at discrete locations near the free surface. The hot spots cause the signal peak; then, the temperature distribution begins to smooth out by thermal conduction, causing the radiance signal to decrease and level off at a signal representing the energy released in the shock front. An unknown "fall time" of the detector electronics may have a small influence on the observed signal shapes"

The brightness temp of the two bands (N & F in Fig 21) of the sample shocked at 3.8 GPa (38 kbar) makes it possible to derive a color temp of 800° for this case, which (according to Von Holle) "must be an average temperature over all hot spots and over the individual temperature distribution resulting from conduction and reaction"

Because of the large difference in the time-time plots for the sample shocked at 2.6 GPa, a color temp cannot be derived for this case

Table 5
Shock Initiation Criteria

Explosive	Density Range (g/cc)	Shock Initiation Threshold Range		Ref
		Pressure (kbar)	Particle Velocity (km/sec)	
PETN	1.60	6.6	0.22	47
PETN	1.59	9.1	0.30	32
PETN (a)	1.59	9.5	0.30	45
PETN (a)	1.71	≤ 14.5	≤ 0.30	45
PETN (a)	1.75	~ 17	~ 0.31	51
PETN	1.71	11.4	0.26	47
PETN (a)	1.0	~ 2.5	~ 0.3	5
HNS	1.39-1.59	16-25	0.54-0.56	32
RDX	1.54-1.64	12.5-15.2	0.40-0.41	32
Tetryl (a)	1.30-1.60	3.0-9.5	0.26-0.30	24
DATB	1.23-1.78	23.6-76.7	0.83-1.01	47
TATB	1.52-1.76	43.2-93.2	0.94-1.16	47
TNT	1.35-1.62	14.6-35.4	0.44-0.59	47
PETN	1.44-1.71	5.0-11.4	0.20-0.26	47

(a) Plane-wave tests; all others are gap tests

A. Critical Particle Velocity

Before proceeding with a description of the various theories that have been proposed for the shock initiation of granular expls, it may be informative to consider a simple initiation criterion suggested by the writer (Ref 32). This criterion is a constant critical particle velocity rather than the commonly-used variable critical pressure. Obviously this criterion is strictly applicable only to expls compared under similar test conditions. However, for a "sensitive" expl like PETN, test conditions are relatively unimportant. This is illustrated in the first group of data in Table 5, which shows very similar results for plane-wave and gap test geometries. There may be, however, some sensitization due to confinement (the SSGT data of Ref 47). Note that the critical pressures range from ~ 2.5 to 17kb (about an 8-fold increase) for 1.0g/cc and 1.75g/cc PETN, whereas the critical particle velocity over this density range is essentially *constant*. The second grouping in Table 5 is for critical parameters over density ranges rather than individual densities. Again note that critical pressures vary substantially whereas critical particle velocities stay nearly constant (except in the SSGT data of Ref 47)

An attractive rationale for the constancy of the critical particle velocity, u_c , has been suggested by Stresau & Kennedy (Ref 54a). They invoke a suggestion of Seely's (Ref 6a) that hot spots in granular expls are produced by jets formed by the interaction of shock-propelled and fractured expl granules which then collide with other granules and generate high temps in this stagnation process. The mean effective jet velocity should be proportional to the particle velocity, u , of the input shock and consequently the mean hot spot temp should be proportional to u^2 . Under comparable test conditions the shock sensitivity of a given expl should be proportional to some critical hot spot temp, T_c , which in turn is proportional to u_c^2 . Stresau & Kennedy suggest further refinements to this treatment but the above is sufficient to explain the observed constancy of u_c

B. Reaction behind Shock Front

In an early in-depth study of the shock-initiation of granular expls (Ref 4) it was claimed that:

- input shock steadily accelerate as they

traverse the acceptor

- detonation starts near the shock front of the input shock
- there is no detonation "overshoot"

Shortly thereafter, Jacobs et al (Ref 7) found that in fairly dense (around 90–95% TMD) TNT and Cyclotols the input shock velocity remained steady, there was detonation "overshoot", and there was evidence of reaction behind the input shock rather than at the shock front as claimed in Ref 4. Since those early studies many investigators have reported reaction in granular expls at some distance behind the input shock front (Refs 20a, 25, 32, 36, 45, 48, 51, 54, 63, 64 & 65)

Exptl evidence for reaction behind the shock front in 1.59g/cc PETN was presented in Vol 8, Fig 10, p P104. Additional evidence is shown for 1.75g/cc PETN in Figs 22 & 23 taken from Ref 51. The height of the initial steep pressure rise in Fig 22 is the amplitude of the input shock. For strong input shocks this rise is followed by an increase in pressure but only after a delay. With weaker input shocks a *decrease* in pressure is observed before the pressure increase. For input pressures below threshold only a slow pressure decay is observed. The pressure-time profiles of Fig 23 were obtained at various distances within the expl. They also show the input shock and a progressively shorter delay for subsequent pressure increase with increase in distance from the impact face. The pressure decay and further pressure rise after the above pressure increase is a gage artifact

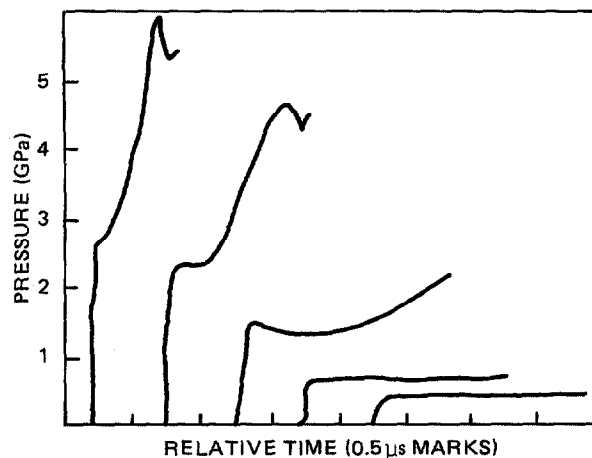

Fig 22 Typical Impact-Face Pressure Histories Measured with Quartz Gauges

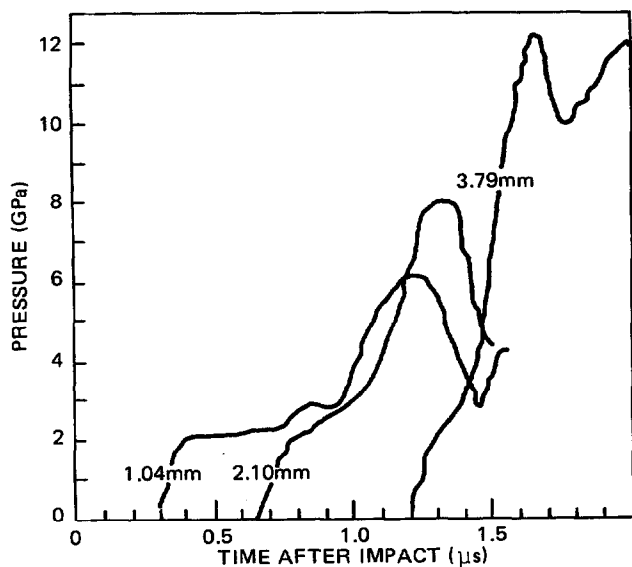

Fig 23 Typical Pressure-Time Profiles from Multiple Embedded Manganin-Gauge Experiments. Labels indicate gauge distances from the impact face

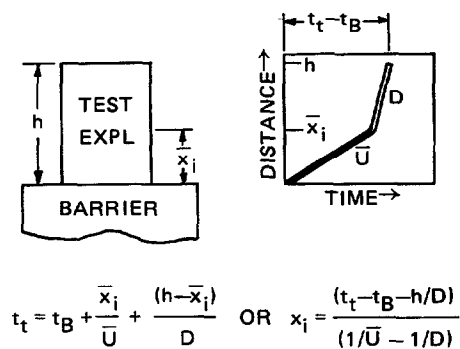

Fig 24 Schematic Representation of Method of Obtaining Initiation Distance, \bar{x}_i , in Gap Test

Similar records have been obtained for PBX 9404 (Refs 37 & 65) and RDX and HNS (Ref 20a). All these records show that *shock-induced decompn begins near the shock entry face forming a compression wave that eventually overtakes the input shock and effects shock-to-detonation transition*

C. Run-up to Detonation

We have already had occasion to employ time-to-detonation or run-up distance to detonation (also called initiation distance) in some of our discussions. Now we will briefly describe how

these data are obtained and in what form they may be presented. Both time to detonation and run-up distance can be read directly from plane-wave wedge shot streak camera records. For pressure gage or time-of-arrival records analysis is more complex and is exemplified by the sketch in Fig 24. Here t_t is the total time from shock entry into the barrier to detonation exit from the acceptor, and t_B is the transit time thru the barrier. Time to detonation is \bar{x}_i/\bar{U}

Run-up data may be presented as x_i vs P_0 plots such as the ones in Ref 20a or more commonly in log-log "pop-plots" such as the one in Fig 25, taken from Ref 11a. References to run-up data were given in Table 3

D. Theories of Shock Initiation

In Section VI we summarized Dremin's suggestions concerning non-equilibrium effects in the shock-initiation of homogenous expls (Ref 67). Some of these ideas are also applicable to granular expls and will be described later. Other theoretical developments, usually highly complex and often more in the nature of curve-fitting

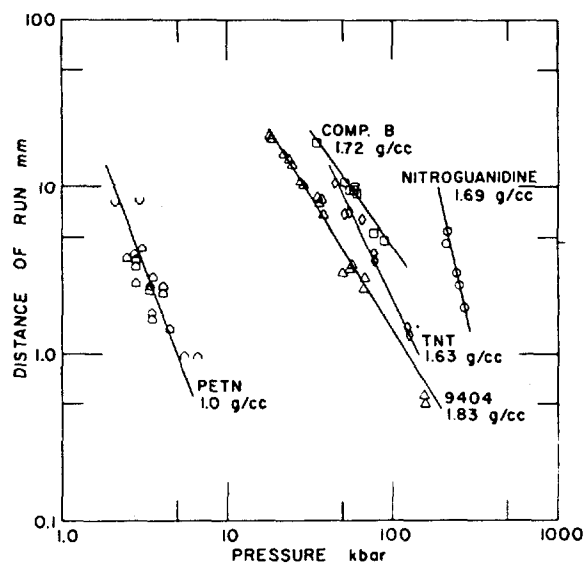

Fig 25 Relationship Between Distance to Detonation and Initial Shock Pressure for Various Explosives. The open symbols for PETN represent the maximum and minimum distances which could be measured. The points are located at the calculated pressures. The data for PETN are taken from Seay and Seely (Ref 5)

than deduction from basic principles, are given in Refs 53, 54, 61, 64 & 65. An exception to this trend is a study by Stresau & Kennedy (Ref 54a) some of whose conclusions will be discussed in the next subsection

Dremin & Shvedov (Ref 52) performed a series of expts with liq expls, granular expls (pressed and cast) and granular expls with inert liq and gas fillers, in which they monitored the barrier/expl interface velocity as a function of input pressure of rectangular shocks. According to the authors the shock-driven interface is decelerated by decompn products if there is reaction. Thus the data in Fig 26 (and in Fig 27 below) are interface deceleration curves. The data in Fig 26a are for liq TNT and those in Fig 26b are for cast TNT; numbers in the curves are input pressures in kbars

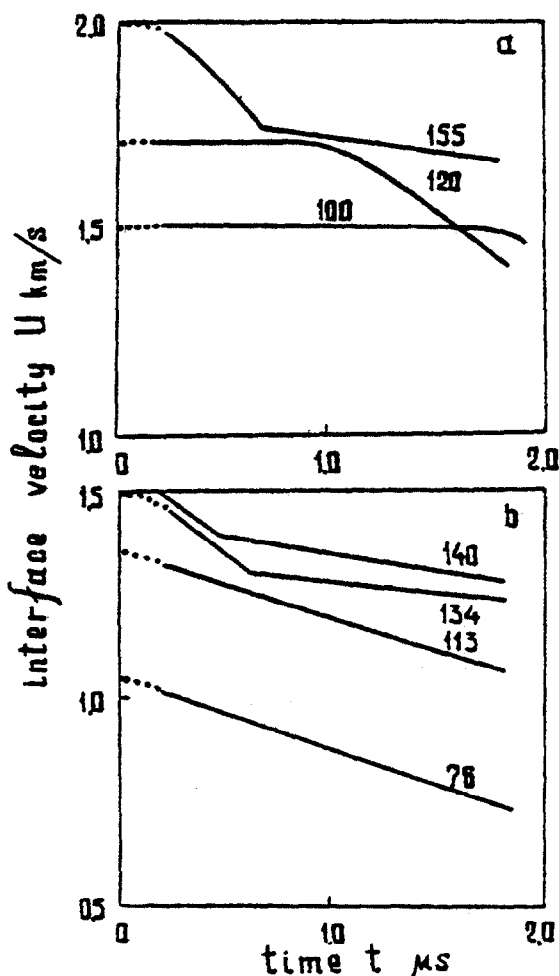

Fig 26 Interface Deceleration Curves for TNT

According to the authors, a decrease in interface velocity with time (negative slope) indicates reaction, whereas zero slope indicates no reaction. This was verified by using appropriate solid and liq "blanks" to show that in these inert materials there is no interface deceleration

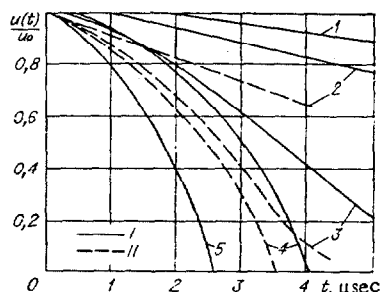

Fig 27 Deceleration of the Interface by Decomposition Products of the Explosive.

I) No 2SW generator; II) No 3SW generator.

1) Ammonium nitrate, $u_0=0.81\text{km/sec}$, $p=13.5\text{kbar}$; 2) TNT, $u_0=0.74\text{km/sec}$, $p=10.5$ and $u_0=1.63\text{km/sec}$, $p=46\text{kbar}$ (No 4 SW generator); 3) Tetryl, $u_0=0.78\text{km/sec}$, $p=11\text{kbar}$ and $u_0=0.89\text{km/sec}$, $p=15\text{kbar}$; 4) RDX, $u_0=0.75\text{km/sec}$, $p=14.5\text{kbar}$ and $u_0=0.9\text{km/sec}$, $p=20\text{kbar}$; 5) PETN, $u_0=0.78\text{km/sec}$, $p=11.5\text{kbar}$; AN, 0.86g/cc , $0.15-65\text{mm}$ grains; TNT, 0.9g/cc , 2mm grains; Tetryl, 0.84g/cc , 0.15mm grains; RDX, 1.0g/cc , 1mm grains; PETN, 0.82g/cc , 0.5mm grains

Deceleration curves for low density expl compacts (Taken from Ref 43a) are shown in Fig 27. Downward curvature of these plots indicates accelerating decompn. Note that the curves show the expected sensitivity order of PETN > RDX > Tetryl > TNT > AN, but even AN appears to be decomp slowly at a shock input of 13.5 kbar. At least for PETN, RDX and Tetryl (and possibly the other expls as well) decompn appears to occur at the shock front. Note, however, that comparison of the input shocks of Fig 27 with the threshold shocks of Table 5 shows that the former are much larger than the latter. Similarly the SSGT initiation threshold for almost voidless TNT is 57kb according to Ref 47, which is considerably below the lowest pressure shown in Fig 26b. Thus the interface deceleration data, and its interpretation of appreciable decompn of

the shocked expl at the shock front, is not necessarily in contradiction to the many studies that show that most of the decomn in many granular expls occurs well behind the shock front for input shocks near the threshold value. The supposition of extensive decomn reactions behind the shock front does not necessarily deny the existence of decomn at the shock front, but it does assign a dominant role to the behind-the-front reactions in generating shock-to-detonation transition

The results and conclusions of the interface deceleration studies may be summarized as follows:

- Within a narrow pressure range, P^* , the behavior of the interface velocity-time profiles changes from either a zero slope or continuous negative slope to a break in the slope (eg, at 155 kb in Fig 26a and 134 & 140kb in Fig 26b)
- The magnitude of P^* is unaffected by the presence or nature of inert liq fillers
- The magnitude of P^* or the time of occurrence of the "break" in the P^* curve is unaffected by the presence, nature and pressure of added inert gases, but the time of occurrence depends on particle size
- The P^* "break" occurs at high input pressures for both liq and granular expls
- The shock front pressure is always greater than P^*

Dremin & Shvedov attribute the early slow-down in the interface velocity (eg, at 155kbar in Fig 26a) to rapid decomn of the expl into products characteristic of detonation, but the reasons for this conclusion are not clearly stated. They also claim that the decomn mechanism of granular expl at pressures greater than P^* is an adiabatic expln mechanism analogous to the one that is obtained in the shock initiation of homogenous expls. At pressures below P^* a different decomn mechanism must predominate. Consequently Dremin & Shvedov assert that a unified theory cannot be developed to cover the entire pressure range of shock initiation. Because the curves (such as those in Fig 26) for liq & granular expls are similar and in each case $P^* < P_{CJ}$ (where P_{CJ} is the pressure of steady detonation), they claim that the detonation reactions in granular and liq expls are similar. This idea of the similarity of the detonation character of granular and liq expls is further de-

veloped in Ref 67. For example, Dremin considers it possible that hot spots in granular expls shocked at pressures above P^* arise by a non-equilibrium heating mechanism similar to that discussed for homogenous expls in Section VI

E. Critical Energy Concept

In the last 15 years the concept that shock initiation can be characterized by a critical energy criterion has been advanced, gained adherents, but currently appears to be on the decline. To the best of the writer's knowledge, this concept was first suggested by Vasil'ev

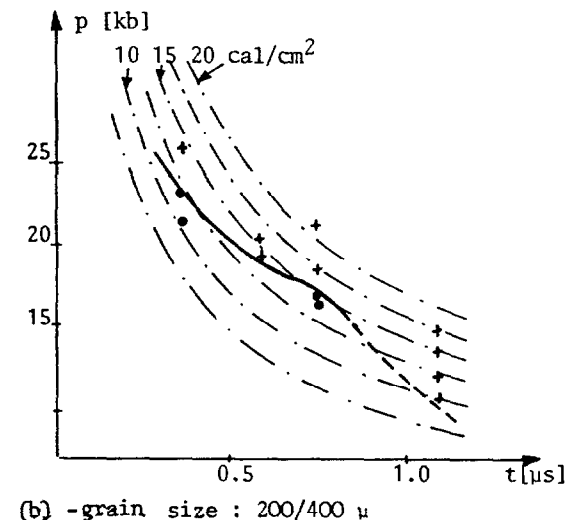
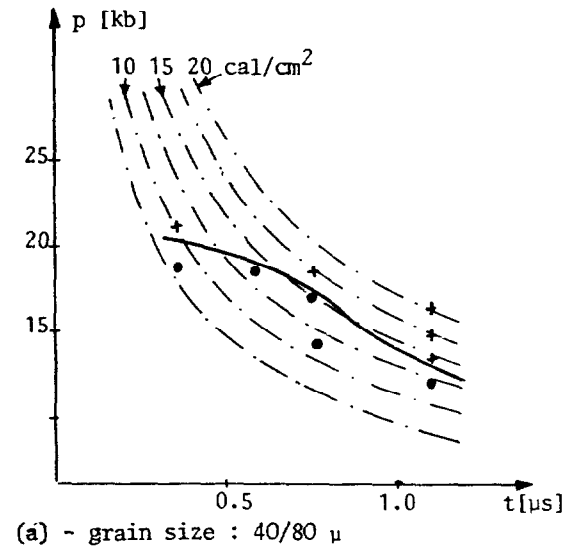

Fig 28 Sensitivity of granular RDX
+ detonation • no detonation

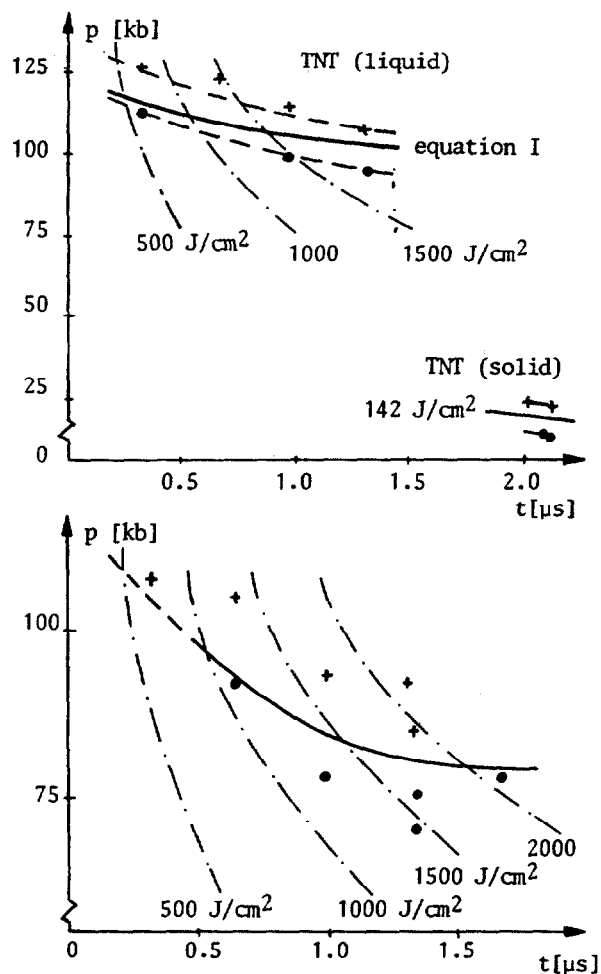

Fig 29 Sensitivity of liquid and solid TNT (a) and nitromethane (b)
+ detonation • no detonation

(Ref 15) who derived a critical energy from the kinetic energy of flyer plates moving just fast enough to initiate TNT. Later Walker & Wasley (Ref 23) put this concept on somewhat firmer theoretical grounds and used their flyer-plate shock initiation data for TNT and LX-04, as well as Gitting's data for PBX 9404 (Ref 11), to provide exptl justification. More recently still, the critical energy concept has received support from Taylor & Ervin (Ref 49), Howe et al (Ref 50) and Titov et al (Ref 53). Taylor & Ervin present data for TNT which they claim supports the critical energy concept. As far as critical energy is concerned, Refs 50 & 53 give some interpretation of the concept but no additional exptl evidence

In its usual form the critical energy concept is really a critical energy fluence concept and is expressed as

$$E_c = \frac{P^2 t}{\rho_0 U} \quad (\text{usually in cal/cm}^2)$$

where E_c is the critical energy fluence, P is the input shock amplitude and t its duration, ρ_0 is the initial density of the shocked expl and U is the initial shock velocity in the expl. Since ρ_0 is constant for a given acceptor, and U changes only slowly with P , $E_c \approx KP^2 t$ where K is a constant

The data shown in Fig 16 (Section IV), which indicate that the detonation-failure region for Comp B can be separated by a single iso-energy curve of 33 cal/cm², provide support for the critical energy concept. However, curves such as the one in Fig 16 are in the minority. Frequently exptl data cannot be fitted to a single iso-energy curve, as for example the data for RDX in Fig 28, and particularly the data for liq TNT and NM in Fig 29 taken from Longueville et al (Ref 55)

In addition to exptl contradictions the critical energy concept is also subject to fundamental theoretical difficulties. For example, as pointed out by Stresau & Kennedy (Ref 54a): "Macroscopic models, such as Walker & Wasley's concept of critical energy fluence and Pastine, Bernecker & Bauer's concept of critical thermal energy, do not explicitly address the point that the concentration of the energy in hot spots is essential to initiation, and its consequence, that the temp of the hot spot plays a significant role in the initiation process. It seems that the distribution, rather than the density, of the thermal energy should be expected to be decisive in the initiation process"

Fauquignon (Refs 48 & 55) suggests that the critical energy concept appears applicable primarily under circumstances where energy release in the shocked expl occurs at a very early stage. Indeed if shock initiation depended mainly on the build-up of decompn reactions near the front of the shock inside the acceptor, it is difficult to see how any complete criticality conditions could be ascribed to the input shock. At best, appropriate characterization of the input shock would only provide a necessary but not sufficient criticality condition. If the controlling

decompn reactions take place near the shock-entry face, appropriate characterization of the input shock (most likely *not* in terms of critical energy as is now done) can provide both necessary and sufficient criticality conditions. Consequently a contradiction arises in that the critical energy concept is expected to be most applicable to homogenous expls, whereas in practice it is found that it is least applicable to homogenous expls (see Fig 29)

In the above quotation from Stresau & Kennedy mention is made of a concept of "critical thermal energy". Some discussion and exptl support of this concept is given in Ref 47. The equations for obtaining the "specific critical energy" are fairly complex. They are formulated in terms of the porosity of the acceptor and its non-reactive Hugoniot, but contain no terms relating to input shock duration. Exptl SSGT data are shown to be in fair accord with theory for several expls. However, there is no indication of what happens under different exptl conditions

F. Shock Heating

Since initiation of detonation is a thermal process it is obvious that a complete characterization of this process requires development of relations between input shock variables and the temp-rise in the acceptor. This problem is still far from solved, particularly for shocks in granular expls. Discussion of the various attempts at obtaining solutions for this difficult problem in homogenous and heterogenous systems is beyond the scope of the present article. Some discussion is provided in Vol 7 under *Hot Spots*, pp H170-175, & *Hugoniots*, pp H183-184. Additional descriptions can be found in Refs 3, 21, 22, 26 and 54a

VIII Shock Initiation of Deflagration

The only studies of this subject known to the writer were made at NOL. In the first of these (Ref 8), a modified gap test was used and the course of shock initiation was followed by high-speed photography. The second study (Ref 8a) also used high-speed photography, but the acceptor disks (50.8mm diam and 12.7mm thick) were submerged in water and subjected to underwater shocks generated by 1-lb spherical Pentolite donors. Input shock amplitude was varied by changing the donor-acceptor separation. Comparison of the results of the two tests is given in Table 6

Table 6
Comparison of Pressure, P_b , at Which Burning Is Just Detectable in the Underwater and Modified Gap Tests

Explosive	Loading Density (g/cm ³)	P_b Underwater (kbar)	P_b Mod. Gap (kbar)
Pentolite	1.67	3	10
60/40 Cyclotol	1.70	4	13
PBX 9404-03	1.83	5	16
TNT	1.62	8	23
LX-04-1	1.86	9	23

Note that underwater deflagration thresholds are about 1/3 those in the modified gap tests. Liddiard (Ref 8a) ascribes this to longer duration and more planar shocks in the underwater expts. In any event, both sets of thresholds are considerably lower than those required to initiate detonation. A direct comparison (from Ref 8) of deflagration and detonation thresholds is shown in the tabulation below:

Explosive	Density (g/cc)	Deflagration Defonation	
		Threshold (kbar)	Threshold (kbar)
50/50 Pentolite	1.64	11	18
Comp B-3	1.72	13	27
TNT	1.62	22	50
Tetryl	1.65	14	18
LX-04	1.86	23	39
PBX 9404	1.83	16	24

Written by J. ROTH

Refs: 1) T.E. Holland et al, *JApplPhys* **28**, 1217 (1957) 2) G.P. Cachia & E.G. Whitbread, *ProcRoySoc, A*, **246**, 268 (1958) 3) A.W. Campbell et al, *PhysFluids* **4**, 498 (1961) 4) A.W. Campbell et al, *Ibid*, 511 (1961) 5) G.E. Seay & L.B. Seely, *JApplPhys* **32**, 1092 (1961) 6) V.S. Ilyukhin & P.F. Pokhil, *DAN (SSSR)* **140**, 179 (1961) 6a) L.B. Seely, *Proc 4th Electric Detonator Symp (Franklin Institute)* (1963) 7a) S. Thunborg et al, *RevSciInstr* **25**, 1 (1964) 8) T.P. Liddiard & S.J. Jacobs, *NOLTR* **64-53** (1965) 8a) *Ibid*, 4th *SympDeton*, 487 (1965) 9) M.C. Chick, *Ibid*, 349 (1965) 10) M.W. Evans et al, *Ibid*, 359 11) E.F. Gittings, *Ibid*, 373 11a) J.B. Ramsay & A. Popolato, *Ibid*, 233 12) J. Eadie, *Ibid*, 399 13) V.M. Boyle et al, 10th-*CombustSymp*, 855 (1965) 14) A.N. Dremin

- et al, *FizGorVzryva* 1, 3 (1965) & *Combust-ExplShock* 1, 1 15) M.Ya. Vasilév, *Ibid*, 1, 45 (1965) & *CombustExplShock* 1, 25 16) D. Price & T.P. Liddiard, *NOLTR* 66-87 (1966) 17) I.E. Lindstrom, *JApplPhys* 37, 4873 (1966) 18) N.L. Coleburn, *AIAAJournal* 4, 521 (1966) 19) A.N. Dremin & S.A. Koldunov, *Vzryvnoe-Delo* 63, 37 (1967) 20) A.N. Dremin et al, *FizGorVzryva* 3, 11 (1967) 20a) J. Roth & J.H. Blackburn, *FinalRept*, **SRI 6208** (1967) 21) I.M. Voskoboinikov et al, *FizGorVzryva* 4, 46 (1968) & *CA* 69, 78872 (1968) 21a) E.F. Kilmer, *JSpacecraft* 5, 1216 (1968) 22) I.M. Voskoboinikov et al, *Ibid* 4, 471 (1968) & *CA* 72, 123575 (1970) 23) F.E. Walker & R.J. Wasley, *Explosivst* (1969), 9 24) I.E. Lindstrom, *JApplPhys* 41, 337 (1970) 25) D. Stirpe et al, *Ibid* 41, 3384 (1970) 26) A.N. Dremin et al, *FizGorVzryva* 4, 520 (1970) & *CA* 75, 89716 (1971) 27) D. Price, *NOLTR* 70-25 (1970) 28) C.L. Scott, *NOLTR* 70-36 (1970) 29) R.J. Wasley & R.H. Valentine, **UCRL-50950** (1970) 29a) F.E. Walker & R.J. Wasley, *Combust&Flame* 15, 233 (1970) 30) B.D. Trott & R.G. Jung, *5thSympDeton*, 191 (1970) 31) D. Price, *Ibid*, 207 32) J. Roth, *Ibid*, 219 33) J.G. Berke, *Ibid*, 237 34) W.W. Marshall, *Ibid*, 247 34a) W.W. Marshall, *Ibid*, 185 35) C.L. Scott, *Ibid*, 259 36) B.G. Craig & E.F. Marshall, *Ibid*, 321 37) J.E. Kennedy, *Ibid*, 435 38) D. Price et al, *Combust&Flame* 17, 323 (1971) 39) H. Bartels, *Explosivst* 20 (1972), 143 40) R.H. Dinegar et al, *Ibid*, 176 41) D. Tabor et al, *Final Rept* **DAJ 37-71-C-3273** (1972) (AD-750706) 42) D. Tabor et al, *Ibid* (1973) (AD-768227) 43) R.H. Dinegar et al, *Explosivst* 21 (1973), 40 43a) S.A. Koldunov et al, *FizGorVzryva* 9, 295 (1973) 44) J.N. Ayres et al, *NOLTR* 73-132 (1973) 45) J. Wackerle & J.O. Johnson, **LA 5131** (1973) 46) L. Avrami et al, **PATR 4690** (1974) 47) R.J. Bauer, **NSWC/WOL/TR 75-67** (1975) 48) C. Fauquignon & Y. deLongueville, *Naval Intelligence Support Center Translation No 3768*, ADA 021183 (1976) 49) B.C. Taylor & L.W. Ervin, *6th SympDeton*, 3 (1976) 50) P. Howe et al, *Ibid*, 11 51) J. Wackerle et al, *Ibid*, 20 52) A.N. Dremin & K.K. Shvedov, *Ibid*, 29 53) V.M. Titov et al, *Ibid*, 36 54) J.W. Numziato, *Ibid* 47 54a) R.H. Stresau & J.E. Kennedy, *Ibid*, 68 55) Y. deLongueville et al, *Ibid*, 105 56) L.C. Yang & V.J. Menichelli, *Ibid*, 612 57) R.O. Weingart et al, *Ibid*, 653 58) F.W. Davies et al, *Ibid*, 740 59) S.A. Sheffield et al, *Ibid*, 748 60) R.K. Jackson et al, *Ibid*, 755 61) J.Q. Searcy & A.C. Schwarz, *Ibid*, 62 62) F.W. Davies et al, *JChemPhys* 64, No 6 (1976) 63) R. Weingart et al, *Preprints, Symp Behavior of Condensed Phases Under High Dynamic Press*, Paris (1978), no pagination 64) L. Green et al, *Ibid* 65) J. Wackerle et al, *Ibid* 66) W.G. Von Holle, *Ibid* 67) A.N. Dremin, *Ibid*
- Shokoladnyi Porokh** (Rus for Chocolate Powder). See under "Dymnyi Porokh" in Vol 5, D1582-R
- Short-Delay Blasting.** The advantages of short-delay (25 to 250msec) over instantaneous or regular 0.5sec delay blasting include a reduction of ground vibration, air concussion and over-break, as well as improved fragmentation and better control of fly-rock
- This method derives its advantages from the fact that, in the shorter time interval involved, while the rock mass is still under the influence of the shock wave from the preceding detonation, the next (and, in turn, each succeeding) detonation occurs. Thus the superimposing of each new detonation wave on an already strained rock mass more readily overcomes its cohesive strength, in accordance with what is known as the "principle of mutual assistance". This results in the advantages listed above, for the same wt of charge, or alternatively, the need for a smaller charge
- Ref:* C.E. Gregory, "Explosives for North American Engineers", *Trans Tech Publications*, Cleveland (1973), 105-17
- Shrapnel.** 1) Strictly speaking, small lead or steel balls contained in a shrapnel case which is fired from an artillery piece. The balls are projected in a forward direction upon functioning of the fuze. Shrapnel is no longer in use by the US Services. 2) Also applied, in popular useage, to munition fragments (Ref 1)
- Historical Note:* In 1784, Lieut Henry Shrapnel,

Royal Artillery, invented what he called a "spherical case shot", which consisted of a hollow iron sphere containing a number of bullets, a bursting charge, and a fuze to fire the charge. The invention was demonstrated before the General Officer Commanding Gibraltar in 1797, and was finally approved for Brit Service use in 1803-04. In the original design the bursting charge was in direct contact with the bullets, and there were a number of premature explosions caused by the friction of the bullets against each other. Capt E.M. Boxer, Royal Artillery, suggested an improved design in which the charge was enclosed in a tube to keep it from contact with the bullets; and in 1840 he improved this again by using a diaphragm to separate charge and bullets (Ref 2)

Refs: 1) Anon, *OrdnTechTerm* (1962), 275-R
2) H.C.B. Rogers, "A History of Artillery", The Citadel Press, NJ (1975), 88-89

Shrike (AGM-45A). US anti-radiation air-to-surface missile for the destruction of ground defensive radar installations. Shrike was developed by the US Naval Weapons Center, China Lake, Calif, and was operationally deployed in 1964. It has a solid-propellant rocket motor; length 304.8cm, diameter 20cm, wing span 91.4cm, wt 177kg, estimated speed Mach 2, range 12-16km

Refs: 1) E. Luttwak, "A Dictionary of Modern War", Harper & Row, NY (1971), 176 2) J. Quick, "Dictionary of Weapons and Military Terms", McGraw-Hill, NY (1973) 3) R.T. Pretty, Ed, "Jane's Weapon Systems-1977", Franklin Watts, NY (1976), 150

Shrinkage and Cavitation in Explosive Charges.

See under "Loading and Fabrication of Explosives" in Vol 7, L46-L to L57-L, and "Hot Spots" in Vol 7, H170-L to H175-R

SH-Salz. Ger for RDX prep'd by the *SH-Process*. See under "Cyclotrimethylenetrinitramine, Cyclonite or RDX" in Vol 3, C614-L

Ref: Urbański 3 (1967), 104-05

Shu Mine. A Ger WWII mine that consisted of 9.5 lb of TNT in a small wooden box, the lid of which was held open with a stick. If the stick was disturbed, the lid was snapped shut, detonating the mine. It could not be detected by electromagnetic mine detectors

Ref: J. Quick, "Dictionary of Weapons and Military Terms", McGraw-Hill, NY (1973), 398

Sicherheitsdynamit. Ger for Safety Dynamite, safe to use in coal mines. They contain 20-25% NG (or a low-freezing mixt of 4/1 NG/Nitroglycol mixed with dinitrochlorohydrin which serves as a phlegmatizer) and a "dope" such as AN, woodmeal, etc. If the NG is phlegmatized by means of collodion cotton, the resulting Dynamite belongs to the *Gelatine Dynamite* class

Refs: 1) Stettbacher (1948), 86 2) B.T. Fedoroff et al, *PATR* 2510 (1958), Ger 177

Sidewinder. US air-to-air missile. Very simple and inexpensive missiles produced in large quantities and used extensively in combat. The basic version, the Sidewinder 1A (AIM-9B), consists of a solid propellant rocket motor, a 10-lb conventional expl warhead, a proximity fuze and an infra-red homing device. Principal characteristics are: length 284cm, diameter 12.7cm, fin span 60.9cm, wt 75kg, speed Mach 2, ceiling over 15000m, and sea-level range 1100m

Sidewinder 1A is still used by almost all NATO and Allied air forces, but in US service it has been replaced by improved versions dubbed AIM-9C/9D, 9E, 9G/H/J, and 9L

Refs: 1) E. Luttwak, "A Dictionary of Modern War", Harper & Row, NY (1971), 176-R 2) J. Quick, "Dictionary of Weapons and Military Terms", McGraw-Hill, NY (1973), 399 3) R.T. Pretty, Ed, "Jane's Weapon Systems-1977", Franklin Watts, NY (1976), 171-72

Siemens' (Spark) Chronograph. See under "Chronographs" in Vol 3, C305-R

Siemens' Powder. Patented in Engl in 1882; was prep'd by treating a mixt of K nitrate, K chlorate,

and a solid plastic hydrocarbon (such as paraffin, pitch, caoutchouc, etc) in a vol solvent for the hydrocarbon. The resulting plastic mass was grained and dried to remove the solvent. See refs under "Chlorate Explosives" in Vol 2, C206-R

Signenits. Rus pre-WWI mining expls contg 1) AN 82, DNT 14 and cellulose 4%; 2) AN 81, NG 1, DNT 14 and vegetable meal 4%
Ref: Anon, SS 12, 409 & 427 (1917)

Signals, Flare or Smoke. See under "Pyrotechnics" in Vol 8, P505-R to P508-R

Signals, Railroad. See under "Railway Fusee", "Railroad Torpedo", etc, in this Vol

Silanes and Derivatives

Silanes (Silicon hydrides). Compds having the general formula $\text{Si}_n\text{H}_{2n+2}$; existing at RT in the gaseous or liq state. Their nomenclature is analogous to alkanes or satd hydrocarbons. The compd analogous to methyl, SiH_3 is called, variously, *silyl*, *monsilane*, or simply *silane*; and Si_2H_6 is analogous to ethyl and is called *disilane*. The series continues in an analogous fashion with *trisilane*, Si_3H_8 , up to the currently identified *octasilane*, Si_8H_{18} . Similarly, a cyclic silicon and hydrogen compd with the formula $(\text{SiH}_2)_x$ is called *cyclosilane* (Refs 26 and 38)

The silicon hydrides are prepd either by acid decompn of Mg silicide or by redn of SiCl_4 with LiAlH_4 (Refs 1-4, 12, 14, 15, 16 & 26). Disilane and other higher hydrides have been conveniently synthesized by subjecting SiH_4 to a silent electrical discharge (Ref 26, p 175). Prepn of individual silanes of ordn interest are given below

Most of the silanes react *explosively* with oxygen; as nascent hydrogen is formed it combines so rapidly with the oxygen that the resulting series of exothermic reactions become a deton (Ref 12, p 25). Hence, precautions must

be taken to exclude air from the silanes when stored or when they are used in reaction systems. Also, an *expl* reaction takes place when Cl or Br is allowed to react with SiH_4 at RT. Similarly, disilane, trisilane and tetrasilane react *explosively* with CCl_4 or chl in the presence of a trace amt of air (Ref 26, pp 176-77). Other chem reactions of the silanes are to be found in Gmelin (Ref 4), Stock (Ref 12), Andrianov (Refs 14 & 15) and Kirk & Othmer (Ref 26)

In general, silanes are highly toxic and can be lethal. They are strong respiratory tract irritants (Refs 24 & 28)

The organo-functional or alkyl-substituted silanes have found great general usage in bonding organic polymer systems (Ref 38). In ordn applications, the alkyl-substituted silanes are used to coat expl particles to provide moisture-proofing and to prevent changes in particle size distribution which would affect the deton vel (Refs 31 & 33). In proplnts the alkyl-substituted silanes are used to either significantly increase the burning rate (Ref 28a) or to modify it (Addnl Limited Dist Refs B & C). They are also used as high energy fuels (Refs 13 & 34) and fuel-binders (Ref 32). In pyrots the invention of Lane and Smith (Ref 27) is of interest. Here, a white smoke generating munition has been produced which uses, typically, poly(methylsilanes) as a fuel. Upon ignition the item burns at about 0.022 inches/sec evolving a smoke whose obscuring power is 5000 ft^3/lb with an efficiency of approx 47% and a yield of about 35%. Of interest at this point is the thinking of Ellern (Ref 23) on the possible use of silanes in pyrots, "... The chemistry and behavior of silanes is ... involved. According to the work by R. Schwarz, based on the studies of Stock and Somieski [1916 (Refs 6 & 12)], only the lower gaseous members of the homologous series SiH_4 , Si_2H_6 , Si_3H_8 ... are stable. They are formed in very complex reactions in which hydrogen is formed ... The need for acid rather than water for silane formation from silicides is one of the reasons why these gases have not found application as illuminants. Another reason is that the flaming is accompanied by some explosive action ..."

There are too many silanes and derivatives of silanes which sponty expld or ignite to be presented in total here (Refs 1 thru 12, 14, 15, 17,

18, 22, 23, 25, 26 & 30). However, one typical example of a silane, alkyl-substituted silane, silyl azide, silylamine, siloxane and a silane polysulfide polymer, which is or can possibly be used in ordn areas, is presented next. Substituted siloxanes are defined and presented separately under "Silicones"

Trisilane (Trisilicopropane, Trisilicon octahydride, Silicopropane or Trisilicane). Si_3H_8 ; mw 92.33; colorl liq; mp -117.4° ; bp 52.9° ; d 0.743g/cc at 0° . Sol in org solvents. Decomp in w; expl reaction with CCl_4 and chl. Prepn is by sepn of mixed silanes obtd by the reaction of Mg silicide with HCl or by the conversion of silane to higher mw silanes in a silent electr discharge app (Ref 36). CA Registry No [7783-26-8]

Trisilane detons on exposure to air with a loud noise and a bright flame. $Q_c -835.1 \pm 7$ kcal/mole; $Q_f -54.1$ kcal/mole. Urbański (Ref 19, p 311) suggests that trisilane, as a typical silane, be added to liq rocket fuels to increase their energy

Triethylmonosilane. $(\text{C}_2\text{H}_5)_3\text{SiH}$; mw 88.52; colorl liq; mp -156.90° ; bp 107.7° , 108.77° (sep vals); d 0.7318g/cc; RI 1.4100. Sol in 95% ethanol; insol in w. Prepn is by partial decompn of triethylmonosilylethylether by treatment with diethyl zinc and Na. The silane decompn explosively when reacted with fuming nitric acid

Silyl Azides. Many of these compns are extremely unstable and several of the aryl substituted compds such as phenyltriazidosilane ($\text{C}_6\text{H}_5\text{N}_3\text{Si}$) deton on handling (Refs 17 & 18). A typical example of an unsubstituted (and unstable) compd is presented next

Silyl Azide. $\text{H}_3\text{Si}=\text{N}-\text{N}\equiv\text{N}$; mw 73.00; N 57.5%; colorl liq; mp $-81.8 \pm 0.5^\circ$; bp $25.8 \pm 1^\circ$. Prepn is by reacting trisilylamine with hydrozoic acid in di-n-butyl ether medium at RT for 2 hrs. The reaction products are sepd from the solvent by fractional distn and are then left for 1/2 hr at RT to complete the reaction. The azide decompn at RT leaving a colorl solid residue and liberating monosilane

Silylamines. The reaction of SiH_3 and SiH_3SiH_2 -halides with ammonia or various primary or

secondary amines is the most successful way to prepare the amines. More than several of the silylamines are sponty flammable or deton in air (Refs 14 & 26). Typical of this group is the trisilylamine presented next

Trisilylamine. $(\text{SiH}_3)_3\text{N}$; mw 107.35; N 13.05%; colorl liq; mp -105.7° ; bp 52° ; d 0.895g/cc at -106° . Prepn is by reacting monochlorosilane with ammonia. The amine detons on exposure to air

Urbański (Ref 19, p 311) suggests that the amine, as a typical silane derivative, be added to liq rocket fuels to increase their energy. The Q_f is approx -10 kcal/mole

Boron salts of the amine called **Silyl-Amino-Boron Compounds** (or Aminoboronsilicone compds) are obtd by the reaction between trisilylamine and a boron halide such as BCl_3 at -78° . A variety of these addn compds, some of which are sponty ignitable in air, are formed in this manner, ie, $(\text{SiH}_3)_2\text{NBCl}_2$ or $(\text{CH}_3)_2\text{-BN}(\text{SiH}_2\text{Br})_2$ (Refs 8 & 26)

Siloxanes (Oxosilanes). Compds analogous to paraffin hydrocarbons consisting of silicon atoms single-bonded to oxygen and so arranged that each silicon atom is linked with four oxygen atoms. In some types of siloxanes hydrogen may replace two or more of the oxygens in the chain. If instead of hydrogens these oxygens are replaced by various organic radicals directly attached to the silicon, the resulting siloxane polymer is called a "silicone" (Refs 26 & 38, p 774 & 776). Silicones are used so extensively in munitions that our material on siloxanes, which properly belongs under "Silicones", is presented separately here under this title

Siloxanes, nevertheless, are used in small amts dissolved in N_2O_4 to reduce heat transfer thru rocket motor walls during combustion. The addn of 0.6 to 1.8% siloxane produces a heat-transfer reduction of greater than 30% (Ref 35a). Also, in the patent of Gordon et al (Ref 35b), rocket motor combustion stability is provided by the addn of a siloxane. A proplnt with a siloxane additive was found to burn with a nearly constant press of 600psig for approx 6 secs, whereas the same proplnt stabilized with cellulose acetate exhibits two press extremes and a continuously decreasing press after less

than 4 secs of burning

A typical example of a sponty ignitable siloxane is presented below:

Disiloxane. $\text{H}_3\text{Si.O.SiH}_3$; mw 78.23; colorl gas; mp -143.6° ; bp -15.2° d 0.881g/cc at -80° . Prepn is by reacting a halogen silane such as bromosilane with w and collecting the prod by inert gas displacement. The prod is sponty air ignitable and burns with a bright yel flame (Refs 4, 6, 12 & 26)

Silane Polysulfide Polymers. These polymers are used as proplnt co-binders to replace pure diethylformal polymers (Ref 20). A typical mercaptosilane monomer is:

Diethyl bis (3-mercaptopropyl) Silane.

$[\text{HS}(\text{CH}_2)_3]_2\text{Si}(\text{C}_2\text{H}_5)_2$; mw 204.49; bp 100–10° at 150 microns; d 0.9523g/cc at 29°; RI 1.5043 at 15°. Sol in benz. Prepn is by refluxing a mixt of dimethyldiallylsilane with thioacetic acid in cyclohexane for three hrs. The excess thioacetic acid is then distd off at 145° and the residual prod hydrolyzed with ethanolic Na hydroxide by refluxing for 4 hrs. After acidification with acetic acid the prod is dissolved in benz and distd off under reduced press. The polymer, **Diethyl bis [3-mercaptopropyl] Silane Polymer**; $[\text{HS}(\text{CH}_2)_3]_2\text{Si}(\text{C}_2\text{H}_5)_2]_x$; mw 1500–1600; lemon yel, clear solid; sol in w; is prepd by first adding an aq soln of I and KI to an aq soln of the monomer. The next step is to decant the w, dissolve the mixt in benz, and react it with HCl. Residual w is then removed with benz. The prod is further polymerized by shaking with $\text{Na}_2\text{S}_2\text{O}_3$ and distg off the benz under reduced press. To use the monomer as a proplnt binder, however, it is extended by blending with various amts of diethylformal polysulfide, and heated for 72 hrs at 70° so as to redistribute the two distinct molecular species. Final cure of the blend is obt'd by using mild oxidizing agents. The burning rate of the polymer blend is 50% greater (0.7 inches/sec at 1000psi) than that of a pure diethylformal binder

Refs: 1) Beil 1 (silanes are entered not as a family of compds but as specific compds and are scattered thruout Hauptwerk, third & fourth edns) 2) Beil 4, 625, 627, 629, 630, (579, 582), [1007] & [1895] 3) Beil 16, [608] & [1198] 4) Gmelin 15, Teil B (1959), 229 ff

& Teil C (1958), 9 ff 5) G.J. Martin, JCS (London) 105, 2860–72 (1914) & CA 8, 1017 (1914) 6) A. Stock & C. Somieski, Ber 52, 695–724 (1919) & CA 14, 1494 (1920) 7) A.E. Finholt et al, JACS 69, 2692–96 (1947) & CA 42, 1144 (1948) 8) A.B. Burg & E.S. Kuljian, "Silyl-Amino Boron Compounds", JACS 72, 3103–07 (1950) & CA 44, 9296 (1950) 9) R.L. Schalla et al, "Combustion Studies of Alkylsilanes", 5th Symp Combustn, 705–10 (1954) & CA 49, 16387 (1955) 10) R.L. Schalla & G.E. McDonald, "Temperature-Composition Limits of Spontaneous Explosion for Nine Alkylsilanes with Air at Atmospheric Pressures", Natnl Advisory Comm Aeronaut Tech Note 3405 (1955) & CA 49, 7248 (1955) 11) H.C. Kelly, "A Literature Survey of Silane, Its Homologs, and Their Derivatives", AFRCR-TN-56-996 (1956) 12) A. Stock, "Hydrides of Boron and Silicon", Cornell Univ Press, Ithaca (1957) 13) Anon, "Organsilanes", BritP 781533 (1957) & CA 52, 2049 (1958) 14) K.A. Andrianov, "Organic Silicon Compounds", Vol I, (Moscow, 1955) TechDoc Liaison Office, MCLTD, WPAFB, Ohio (1958) 15) Ibid, Vol II, 16) G. Brauer, Ed, "Handbook of Preparative Inorganic Chemistry", 2nd Edn, 1, Academic Press, NY (1963), 679–82 17) W. Sundermeyer, "Zur Darstellung der Silylazide", Ber 96, 1293–97 (1963) & CA 58, 6854 (1963) 18) E.A.V. Elsworth & M.J. Mays, "The Preparation and Properties of Silyl Azide", JCS 1964, 3450–54 & CA 61, 11599 (1964) 19) Urbański 3 (1967), 311–12 20) W.W. Schwarz & R.D. Lowrey, "Silane Polysulfide Polymers as Solid Composite Propellant Binders", JAppPolymSci 11, 553–66 (1967) & CA 67, 45694 (1967) 21) Ref No not assigned 22) W.L. Ripley, "Air and Water-Reactive Chemicals", NAD-CR-RDTR-124 (1968) 23) Ellern (1968), 19–21 24) Sax (1968), 1088 25) J.R. Gibson & J.D. Weber, "Handbook of Selected Properties of Air- and Water-Reactive Materials", NAVAM-DEP, RDTR-144 (1969), 90–91 26) Kirk & Othmer 18 (1969), 172–221 27) G.A. Lane & W.A. Smith, "Pyrotechnic and Smoke Producing Compositions", USP 3471345 (1969) & CA 72, 4848 (1970) 28) J.C. Gage, "Subacute Inhalation Toxicity of 109 Industrial Chemicals", BritJIndMed 1970, 27(1), 1–18 & CA 73, 12650 (1970) 28a) J. Green, "High Burning-

Rate Solid Propellant Having a Silicon-Carboranyl Copolymer Fuel Binder", USP 3738878 (1967) & CA **72**, 147869 (1970) 29) M.H. Kaufman et al, "Ammonium Perchlorate . . . Coated with a Silane . . . Complex for Use in Composite Propellant Formulations", USP 3551222 (1970) & CA **74**, 89332 (1971) 30) R. Sack & W. Soeder, "Ignition Groups and Explosion Classes of Gases and Vapors Determined by the German Standard Specification TGL 14275", ChemTech-(Leipzig) **1970**, 22(11), 687-88 & CA **74**, 143967 (1971) 31) L. McDonald, "Conditioning Particulate Materials for Use in Organic Explosives", USP 3403061 (1971) & CA **75**, 131274 (1971) 32) G.A. Lane, "Caseless Rocket Containing a Silane Polymer", USP 3665862 (1972) & CA **77**, 103776 (1972) 33) W.D. Seals, "Pressure Sensitive Explosive with Organosilane Coating", USP 3767488 (1973) & CA **80**, 61725 (1974) 34) E. Veldung, "Rocket Fuels", GerP 2231008 (1974) & CA **80**, 110520 (1974) 35) C. Markin & H.L. Williams, "Nonreinforcing Filler-Elastomer Systems-2. Silane-Treated Ammonium Perchlorate in Polybutadiene", JApplPolymSci **18** (1), 21-43 (1974) & CA **80**, 97051 (1974) 35a) K. Berman et al, "Additives for Heat-Transfer Reduction in the Propellant Combinations Nitrogen Tetroxide-MMH [Monomethylhydrazine] and Nitrogen Tetroxide-A-50", JSpacecRockets **1973**, 10 (8), 493-95 & CA **82**, 127132 (1975) 35b) S. Gordon et al, "Rocket Motors", CanP 987113 (1976) & CA **85**, 80523 (1976) 36) Merck (1976), 1251 (Nr 9420) 37) R.S. Neale & T.C. Williams, "Fluorodinitro Silicon Compounds . . . Nonhydrolyzable Silanes", Union Carbide, Tarrytown (1977) & CA **87**, 154290 (1977) 38) CondChemDict (1977), 773

Addnl Refs (Limited Distribution): A) J.K. Mitchell & W.S. Crownover, "Investigation of Coupling Agents for Use in the Reinforced Grain Concept", RK-TR-68-13, DA Proj Nr 1S223001-A205 (1968) B) W.E. Hill, "New Burning-Rate Modifiers", Rohm & Haas TRS-230, Huntsville, Contract DAA H01-69-C-0772 (1969) C) S.F. Reed, Jr, "Silicon-Containing Modifiers for High-Rate Propellants", Rohm & Haas TRS-279, Huntsville, Contract DAA H01-70-C-0146 (1970)

Silberazetylenid. Ger or Swiss for Silver Acetylide. See in Vol 1, A79-R

Silberazid. Ger or Swiss for Silver Azide. See in Vol 1, A597-R to A612-R

Silberrad Explosives. Chlorate and perchlorate expls contg aromatic nitro compds, patented by O. Silberrad in Engl in 1911. Typical formulations contain K chlorate or Amm perchlorate 63-70, MNT 12-14, DNT 6-7, MNN 6-7, woodmeal 5-6, and sol NC (collodion cotton) 0.5 to 2.5%
Refs: 1) O. Silberrad, BritP 13443 (1911) & CA **6**, 3525 (1912) 2) Colver (1918), 160 & 676

Silberrad Plastic Explosives. See under "Nitrol" in Vol 8, N135-L

Silesia Explosives. See under "Colophony or Rosin" and "Colophony, Nitrated" in Vol 3, C403-R to C404-L; and under "Chlorate Explosives" in Vol 2, C206-R

Silesite. A chlorate expl patented in Engl in 1889 by Pietrowitz and Sieger contg K chlorate

Silica. See under "Silicon Dioxide" in Vol 8, O49-R to O50-R

Silica Gel [Silicic acid (precipitated) or (a form of) Amorphous silica]. $\left[\begin{array}{c} \text{H} \\ | \\ \text{Si}-\text{O}-\text{Si} \\ | \\ \text{H} \end{array} \right]_x$ (?); mw (72.12)_x (?); white powdr or lustrous granules; mp 1850°; d (true) 2.20g/cc; RI (with 11.8% w content) 1.40, (with 26.6% w content) 1.415-1.430, (with 91.4% w content) 1.365-1.380. Sol in aq alkaline solns, aq ammonia, HF and HCl; sl sol in nitric or sulfuric acids. Normal d (apparent bulk d of 0.67 to 0.75g/cc) silica gel has a surface area of from 770 to 830m²/g and is a strong adsorber of w (to 100% on a wt basis), gases, org compds, etc. A comml prepn is by a slurry process: Na silicate is mixed with an

acid such as HCl at a pH and silica concn such that a gelatinous ppt is formed; mixing may be by batch or semicontinuous process. The silica hydrogel is then washed either before or after drying. The drying is usually achieved by a rapid spray technique (Ref 8). Lab prepn is by hydrolysis of tetramethoxy silane; 50g of the ester are added to 80ml of double-distd w in a large Pt dish and heated to 40–50° while stirring with a Pt spatula for 15 mins. The gel increases markedly in vol upon standing for one hr in a warm place. The prod is then air-dried for 48 hrs at 80° (Ref 3)

In Kramer and Strauss' patent (Ref 6), a ceramic-polyethylene-phenolic resin ablative heat shield compn, silica gel is used as a heat-resistant stabilizer constituent (5.20%) giving this composite the property of having a high visc at its decompn point, thus extending the useful life of the shielding. A 0.5% addn of silica gel to aluminized expls such as Tritonal has been found to increase the storage life of these expls by adsorbing small amts of moisture (0.20%) before the moisture reacts with the Al to evolve decompn gases (Ref 2). The patents of Simpson et al (Refs 7 & 9) recommend the use of silica gel as a gelling agent in the manuf of nitric acid-AN blasting compns. Silica gel is also used as a thickening agent in Nitroglyceroglycol-based expls (Ref 11) and AN-Na nitrate aq slurry expls (Ref 15). In proplnts, the patent of Hubbuch et al (Ref 10) uses silica gel as a support for an oxidizing agent such as K permanganate, the combination serving as the proplnt initiator; and in the work of Arsh et al (Ref 12), 1 to 5% silica gel is used as a burning rate accelerator in Amm perchlorate-based proplnts

The US military specification (Ref 4) contains the following requirements:

Table 1
Silica Gel Specification Requirements

<u>Characteristic</u>	<u>Requirement</u>
Silica, % ^a	99.6 min
Iron, as Fe ₂ O ₃ , % ^b	0.03 max
pH ^c	3.5 min
Density, lbs/cu ft ^d	45–48
Water vapor absorption capacity at 77°F, % ^e	
At 10% RH	5.7 min
At 20% RH	10.5 min
At 40% RH	22.0 min
At 60% RH	33.25 min
At 80% RH	36.0 min
Granulation ^f	
Retained on No 6 (3.35mm), % thru No 6, retained on	2.0 max
No 10 (2.00mm), % thru No 10, retained on	55.0 min
No 16 (1.18mm), % thru No 16, %	19.0 min
thru No 20 (850 microns), %	3.5 max
	0.5 max

Footnotes to Table 1:

- a – Gravimetrically after the acidification and ignition of the sample
- b – Colorimetrically at 510m μ after development of the ferrous-o-phenanthroline complex orange-red color
- c – By measurement with a pH meter
- d – By volumetric measurement of a 50 \pm 0.1g sample of the silica gel
- e – By measurement of the time reqd for a 6 to 10g sample of the silica gel to exhibit no further wt gain after repeated exposure to each of the series of RH's in ascending order. The test shall be considered complete if at any time the min spec values are obtd
- f – By wt difference of each US Standard sieve after mechanically shaking for 5 mins a 100g sample thru the specified nest of sieves

Refs: 1) Gmelin, System Nr 15, Teil B (1959), 457 ff 2) K.S. Warren, "Study of Effect of Moisture on 80/20 Tritonal", PATR 1560 (1945) 3) G. Brauer, Ed, "Handbook of Preparative Inorganic Chemistry", 2nd Ed, Vol 1, Academic Press, NY (1963), 698 4) Anon, "Silica Gel", MIL-S-14759 (1968) 5) Sax (1968), 1089 6) I.R. Kramer & E.L. Strauss, "Thermoplastic Ablation-Shield Material Having a High Viscosity

at Its Decomposition Temperature", USP 3397168 (1968) & CA **69**, 78119 (1968) 7) R.A. Simpson et al, "Gelled Nitric Acid Blasting Agent", USP 345438 (1969) & CA **71**, 51824 (1969) 8) Kirk & Othmer, "Amorphous Silica", **18**, 61-72 (1969) 9) R.A. Simpson, "Gelled Nitric Acid Blasting Agent", USP 3442728 (1969) & CA **71**, 31969 (1969) 10) T.N. Hubbuch et al, "Gas Generation Carrier", USP 3535262 (1970) & CA **74**, 33210 (1971) 11) Anon, "Nitroglyceroglycol-Based Explosive Mixtures", FrP 2116769 (1972) & CA **78**, 161720 (1973) 12) M.M. Arsh et al, "Combined Effect of Catalysts and Heat-Conducting Elements on Combustion Rate", IzvVysshUchebZavedKhimKhim-Tekhnol **1974**, 17 (1), 35-39 (Russ) & CA **80**, 147428 (1974) 13) Merck (1976), 1099 (No 8232) 14) ChemRubHdbk (1978), B-155 15) P. Barnhard et al, "Aqueous Slurry Explosives with Colloidal Hydrous Metal Oxide", USP 4058420 (1976) & CA **88**, 52662 (1978)
Addnl Refs (Limited Distribution): A) F.A. Armstrong & R.T.M. Fraser, "The Silica Gel Process: Small Scale Studies. Part 1: Comparison of Catalysts and Labelling Experiments", **ERDE TR 113**, Waltham Abbey (Engl) (1972)
 B) D.M. French, Ed, "Summary of Published Research on Binders and Propellants", **NAVORD IHTR 392** (1973)

Silicates. A general term applied to a great number of compns and compds, both natural and synthetic, contg silicon, oxygen and one or more metals, with or without hydrogen. Silicate organic esters such as ethyl silicate (see in Vol **6**, E330-L) are also formed with organic alcohol groups. Many minerals are silicates as well as most rocks (except limestone and dolomite). Examples of other natural silicates are asbestos, beryl, clays, feldspar, gemstones (except diamond), mica, etc. Silicates have found extensive usage in cements, the well-known Portland cement containing a large amount of calcium silicate

Ordn usage of silicates falls into two source categories, natural and synthetic. Natural silicates such as kaolin, mica, feldspar or talc have been added to various energetic materials, such as the work of Kraemer et al (Ref 11), where it is suggested that a silicate be used to attenuate the

power/vol ratio of slurried, semiplastic or plastic expls; the solid rocket double-base proplnt compns of Sayles (Refs 15 and 15a), where 0.1-1% silicate materials are used to inhibit erosive combustion from proplnt grains with large length/diameter ratios; proplnts patented by Kishi et al (Ref 16) for automobile safety bag inflation; and pyrot smoke producing compns patented by Lane and Smith (Ref 10) where a porous silicate is suggested for use as a fuel carrier

Two varieties of synthetic silicates are used in ordn technology - Ca and Na silicates. These are presented below:

Calcium Silicate. Exists in a variety of forms with varying percentages of w of crystn. Its known parameters are tabulated in Table 1

The compd can be found naturally in minerals such as afwillite, centrallasite, foshallisite, grammite, larnite, okenite, table spate and xonalite. Comml prepn usually consists of reacting a mixt of lime and diatomaceous earth under carefully controlled conditions so that the product has predictable absorbing power; about 1-2.5 times its wt in liqs while remaining a free-flowing white or sl cream-colored powder. Typical total absorption values are, w 600%, mineral oil 500%. Avail surface area is 95 to 175 sq m/g (Ref 15b)

An important usage for calcium silicate resulted from the work of Jerscerzewski (Ref 4) who used the silicate as an *absorbant* to prevent the exudation of TNT (a result of high temp storage) in the 8-inch M106 shell. In an almost 100% effective procedure designed for assembly line shell loading, 1.25% of Ca silicate is added to the molten TNT. The mixt is then allowed to cool until proper pouring consistency is obtained. Heinemann and Lowell (Ref 5) successfully extended this work to the following expl compns (and % Ca silicate) used in mines and missile or rocket warheads: Comp B (0.50), HBX-1 (0.49), HBX-3 (0.37) and H-6 (0.38). Another important usage of Ca silicate in expls is reported by Schimmel and Heredia (Ref 5a) who improved the stability and effectiveness of HBX compns by replacing both the D-2 desensitizer and the Ca chloride drying agent with Ca silicate (see in Vol 7, H23-R to H35-R under

Table 1
Calcium Silicates

Calcium Silicates, Nomenclature ^a	Formulae	mw	Crystn form	mp, °	bp, °	d, g/cc	RI	Sol in w, g/100cc
Meta silicate (α)	CaSiO ₃	116.16	colorl monocl	1540	—	2.905	1.610, 1.611, 1.664	0.0095 at 17°
Metasilicate (β)	CaSiO ₃	116.16	colorl monocl	trans pt at 1200	—	2.5	1.616, 1.629, 1.631	—
Di-orthosilicate (I)	Ca ₂ SiO ₄	172.24	colorl monocl	2130	—	3.27	1.717, 1.735	—
Di-orthosilicate (II)	Ca ₂ SiO ₄	172.24	colorl rhomb	trans pt to (I) at 1420	—	3.28	1.717, 1.735	—
Di-orthosilicate (III)	Ca ₂ SiO ₄	172.24	colorl monocl	trans pt to (II) at 675	—	2.97	1.642, 1.645, 1.654	—
(Tri) silicate	Ca ₂ SiO ₅ or (3CaO.SiO ₂)	228.32	colorl monocl	1900	—	—	α 1.718, β 1.724	—
Commercial	approx 3CaO.SiO ₂ .H ₂ O	244.32	white powdr	—	—	—	—	—

a - CA Registry Nr [1344-95-2]. Refs to Table are 15b and 18

“HBX”). Similarly, they improved Comp B by replacing the desensitizing wax with Ca silicate (see in Vol 3, C477-R to C482-L, under “Composition B Type Explosives . . .”). A further search of the literature has revealed several current patents of interest, one being that of Ryan and Vodoklys (Ref 14). In this application Ca silicate is suggested for use as a spotting phosphor in the tagging of expls to provide post-deton information. In this invention two types of phosphors are used, a spotting and a coding phosphor. The spotting phosphor (Ca silicate) is activated by Mn and excited by ultra-violet to produce readily detectable band-type (optical) emission which is not detectable at the excitation wave lengths (line-type emission at 325nm) that the coding phosphor emits. An example of a coding phosphor is yttrium vanadate which is activated by trivalent rare earths. In another invention, that of Andersson (Ref 12), Ca silicate powdr of less than 6mm particle size is suggested for use as an adsorbing

matrix for various smoke- or gas-producing materials such as TiCl₄, SiCl₄ or HClSO₃ which form greater than 40% of the total vol of the pyrot charge

The US military specification (Ref 9a) contains the following chem and physical requirements for Ca silicate used as an absorbant in expls

Table 2
Ca Silicate Specification Requirements

Ingredient	Chemical Requirements	
	Max, %	Min, %
Total volatile matter ^a	9.0	—
Total silicon as SiO ₂ , dry basis ^b	64.0	52.0
Total Ca as CaO, dry basis ^c	32.0	23.0
Sum of percent SiO ₂ , CaO, and loss of wt on ignition, dry basis ^d	—	97.0
pH ^e	9.0	7.5

Footnotes to Table 2

- a - Gravimetrically, by drying a 5g sample to constant wt at $105 \pm 5^\circ$
- b - Gravimetrically, after extraction of the Ca as CaCl_2 with aq HCl, conversion of the silicon to SiO_2 with $\text{HF}/\text{H}_2\text{SO}_4$ acid oxidation and ignition
- c - By redox titrimetry using 0.1N K permanganate after conversion of the Ca in the specimen to Ca oxalate
- d - By calculation
- e - By measurement with a Beckman (or equal) glass electrode pH meter of a 100ml cold distd w extract of a 10g specimen

Physical Requirements

Property	Min, %	Max, %
Retained on 140 mesh (106μ) sieve ^a	—	1.0
Retained on 325 mesh (45μ) sieve ^a	—	6.0
Meta-nitrotoluene adsorption ^b	550g/100g	—
Grit ^c	—	0.01
Color ^d	—	—
Workmanship ^e	—	—

Footnotes to Table 2

- a - Gravimetrically, after drying for 4 hrs at $105 \pm 5^\circ$ the residue of an aq slurry which has been washed thru a nest of two sieves
- b - By measuring the vol of rapidly added meta-nitrotoluene at which a 5g specimen becomes sl fluid
- c - Gravimetrically, by drying at 105° and weighing the residue retained on both of the

sieves. The residue shall not produce a scratching noise or scratch a glass slide when placed between two glass slides which are then rubbed together

- d - The specimen shall be white in color
- e - The Ca silicate shall be free of dirt, oil, grease, moisture and other foreign material

In general silicate dusts are toxic by inhalation with tolerances ranging from 5 to 50 million particles per cu ft of air (Ref 7)

Sodium Silicate. Exists in a variety of forms.

The forms used in ordn work are usually either the aq soln (Ref 6a), or the *meta* or *ortho* solid forms. The parameters for the meta or ortho forms are tabulated below in Table 1

Prepn of Na_2SiO_3 is by fusion of sand (SiO_2) and soda ash (Na_2CO_3) in a Pt crucible at 1150° (Refs 6 and 15b). Prepn of $\text{Na}_2\text{SiO}_3 \cdot 9\text{H}_2\text{O}$ is by mixing water-glass (Na_2SiO_3) with an aq soln of NaOH to form a soln which is seeded to produce, on standing at RT, the appropriate metasilicate crystals (Ref 6). Sodium orthosilicate prepn is by fusion of silica with Na carbonate at about 1450° , forming an "integral" mixt of caustic soda and Na meta silicate (no true compd is formed) (Ref 9, p 138-39)

Current patents of interest describing usage of Na silicate in energetic materials include the invention of Kobayashi et al (Ref 13a), where it is suggested that microspheres of 40-80 μ in diam be added (in amts of from 0.5 to 3.0%) to AN-based slurry expts to lower the d and increase the sensitivity of the slurry, and the work of Szikora (Ref 13), who suggests that a

Table 1
Sodium Silicates

Sodium Silicates Nomenclature ^a	Formulae	mw	Crystn form	mp, °	bp, °	d, g/cc	RI	Sol in w, g/100cc
Meta silicate	Na_2SiO_3	122.06	colorl monocl	1088	—	2.4	α 1.518 γ 1.527	Sol
Meta silicate	$\text{Na}_2\text{SiO}_3 \cdot 9\text{H}_2\text{O}$	284.20	colorl rhomb bipyramid	40-48	100	—	—	V Sol
Orthosilicate	Na_4SiO_4	184.04	colorl hex	1018	—	—	1.530	Sol

a - CA Registry Nr [1344-09-8]. Refs to Table are 15b and 18

coating of Na silicate be used to raise the heat resistance of an igniter mixt consisting of K perchlorate-Zr-wood charcoal approx 40° while maintaining the electrical resistance sufficiently to cause ignition on electrical current application. Ellern (Ref 8, p 316) has suggested the use of alkali cements such as Na silicate as non-gassing binders for energetic materials, especially pyrots

The US military specifications embodying the requirements for Na silicate are presented in **O-S-604 C (1)** for "Sodium Metasilicate, Technical" (Ref 12a), **P-S-651E (1)** for "Sodium Orthosilicate, Technical" (Ref 12b) and **O-S-605D** for "Sodium Silicate Solution" (Ref 6a)

Toxicity is the same as stated under Ca silicate above (Ref 7)

Refs: 1) Gmelin, Syst Nr **15**, Teil B (1959), 182 ff
 2) W.F. Ehret, "Smith's College Chemistry", 6th Edn, D. Appleton-Century, NY (1946), 461-64 & 480 3) J. Kleinberg et al, "Inorganic Chemistry", Heath, Boston (1960), 365 4) E. Jeszczewski, "Evaluation of Absorbent as an Exudation Preventative in the 8-inch M106 Shell", **PAAG DB-TR 1-60** (1960)
 5) R.W. Heinemann & S.J. Lowell, "Prevention of Exudation from Ammunition Items", **PATR 2675** (1960) 5a) R.T. Schimmel & R.T. Heredia, "Stability of H-6, Comp B and Modifications of the Same", **PAAG TR-100** (1961)
 6) G. Brauer, Ed, "Handbook of Preparative Inorganic Chemistry", 1, 2nd Edn, Academic Press, NY (1963), 704-06 6a) Anon, "Sodium Silicate Solution", **O-S-605D** (Feb 1967)
 7) Sax (1968), 1089 8) Ellern (1968), 316; 326 ff 9) Kirk & Othmer **18** (1969), 134-66
 9a) Anon, "Calcium Silicate, Technical", **MIL-C-51077 (MU)-AMENDMENT 2** (1969)
 10) G.A. Lane & W.A. Smith, "Pyrotechnic Smoke-Producing Compositions", USP 3471345 (1969) & **CA 72**, 4848 (1970) 11) S. Kraemer et al, "Powdered Semiplastic, Plastic, or Slurried Explosives", USP 1956982 (1969) & **CA 75**, 111356 (1971) 12) R. Andersson, "Smoke- or Gas-Producing Composition", BritP 1302736 (1970) & **CA 78**, 99969 (1973) 12a) Anon, "Sodium Metasilicate, Technical", **O-S-604 C (1)** (April 1973) 12b) Anon, "Sodium Orthosilicate, Technical", **P-S-651 E (1)** (Aug 1974)
 13) S. Szikora, "Percussion Caps With Enhanced Heat Resistance", HungP 9267 (1973) & **CA**

83, 30484 (1975) 13a) M. Kobayashi et al, JapP 75142715 (1975) & **CA 84**, 108031 (1976)
 14) F.M. Ryan & F.M. Vodoklys, "Combination of Band-Type and Line-Type Emission Phosphors With Explosive", USP 3967990 (1975) & **CA 85**, 114571 (1976) 15) D.C. Sayles, "Non-Erosive, Solid Rocket Propellant Compositions", USP 3969166 (1975) & **CA 85**, 162924 (1976) 15a) Ibid, USP 3979236 (1975) & **CA 85**, 162937 (1976) 15b) Merck (1976), 215 (Nr 1705), 1120 (Nr 8443) and 1120-21 (Nr 8444) 16) K. Kishi et al, "Propellants", JapP 76125678 (1975) & **CA 86**, 75490 (1976)
 17) CondChemDict (1977), 773 18) Chem-RubHdbk (1978), B-101, B-162 & F-158

Silicides. Crystn compds formed from silicon and various other elements of metallic, transitional or non-metallic character. A complete discussion of silicides is to be found in the work of Sansonov (Ref 9). Those silicides of ordn interest are presented below

Calcium Silicide, CaSi_2 ; mw 96.25; rhombic crystals; d 2.5g/cc. Sol in acids and alkalis; insol in cold w. Decompd by hot w. Prepn is by fusing Ca and Si together in vacuo at above 1000° (Ref 9, p 65). Ca silicide reacts violently with aq HCl to form hydrogen and disilane which deton in air [Refs 9 (pp 223-24), 10 & 11].

The silicide has been used in many expl formulations to increase sensy and power. An early patent claiming this action (Ref 2) incorporates 6-18% of various silicon compds including silicides, with the balance of the expl compn consisting of Amm Perchlorate, NC and TNT; in the patents of Segay (Refs 3 and 4), AN and AN-TNT based expls incorporate from 13.8 to 27% calcium silicate; and Pronk and Bower (Ref 5) include 15% Ca silicide in their patented Amm Perchlorate based formulations. However, the work of Médard (Ref 6) indicates that with the addn of from 5 to 30% Ca silicide to mixts with either PA or RDX as the principal constituents, an avg increase of only 6.6% in Trauzl (Pb block) expansion resulted when compared to the Trauzl results of neat samples of either expl. The work of Sartorius (Ref 8) is also pertinent at this point. He investigated expl compns consisting of 85 or 90% PA, PETN, RDX or TNT

with 15 or 10% Ca silicide and found that their power (by Trauzl test) is only slightly higher (3.4% avg) than for corresponding expls without the silicide. Belgrano (Ref 7, pp 184–86 and 284) lists a number of AN based expl compns which incorporate from 5 to 8% Ca silicide. It is claimed that this addn results in higher values for power (again, Trauzl test), deton vel and expln temp. However, it is also noted that these expls are approx *twice* as sensitive to mechanical action with the silicide addn than without it

For examples of expls using Ca silicide instead of Al as a high energy fuel, see (under "Italian Explosives") in Vol 7, I170-L, "Piom-bite", and I177-L, "Sabulite"

A fuzing application for Ca silicide is discussed in a current Brit patent (Ref 18) which claims mechanically insensitive and thermally stable timing fuses with burning rates of 100–500 sec/m (with a variation of $\leq 2\%$) can be manufd with a pyrot type powder core consisting of 20–67.3% K nitrate, with the remainder Ca silicide. The silicide is also used as a fuel in *priming* compns. Meyer (Ref 1) suggested that it be used to the extent of 15% with MF (25%), Ba nitrate (35%), Sb sulfide (15%), Ba chromate (4%) and powdered glass (6%). In Weale's invention (Ref 6a) the silicide is mixed with LA (5–15%), Ba nitrate and tetrazene (10–15%). In Franz's primer patent (Ref 8a) it is claimed that a mixt of diazodinitrophenol (20%), tetra-cene (5%), Pb ethylenedinitramine (25%), Ca silicide (20%), Ba nitrate (24%), Pb peroxide (6%) and gum arabic (0.5 parts) has an expln temp greater than 300°, low friction and impact sensy and relatively high flash pt

The US military specification (Ref 15) contains the following requirements for Type I and Type II Ca silicide

Table 1
Calcium Silicide,
Chemical and Physical Requirements

Requirement	Type I	Type II
Moisture (max), % ^{-a}	0.1	0.1
Silicon (min), % ^{-b}	60.0	60.0
Total iron (max), % ^{-c}	10.0	3.0
Calcium (min), % ^{-d}	20.0	32.0
Total silicon, calcium and iron (min), % ^{-e}	92.0	—
Metallic iron (max), % ^{-f}	0.2	—
Alkalinity (as CaO)(max), % ^{-g}	2.0	—
Free Carbon (max), % ^{-h}	3.0	—
Carbides and phosphides, % ⁻ⁱ	≤ 2.0 ml	—
	of titrant	
Apparent density (max), g/cc ^{-j}	1.50	—
Apparent density (min), g/cc ^{-j}	1.20	—

Footnotes to Table 1:

- a - Gravimetrically, by weighing a 10g sample before and after heating at 100–10° for one hr
- b - Gravimetrically, by weighing the residue of a 0.5g sample after alkali fusion, w washing, acid extraction of sol materials, and ignition
- c - By redox titrimetry of the ferrous ion using 0.1N K permanganate titrant
- d - By redox titrimetry of Ca oxalate using 0.1N K permanganate as the titrant
- e - By calculation
- f - By redox titrimetry of ferrous ion using 0.1N K permanganate as the titrant
- g - By acid-base titrimetry using 0.1N HCl as the titrant to a methyl orange end pt
- h - Gravimetrically, by a loss-in-wt procedure (weighing before and after sample residue ignition) after a series of steps beginning with the exposure of a sample to chlorine gas, thus forming Si chloride, followed by HCl-water extraction of the acid-water solubles (including Si chloride, iron and Ca), then oven drying and weighing of the residue
- i - By titrimetry, using 0.1N NaOH soln as the titrant, to a permanent turbid end pt of a soln of the carbide and phosphide materials in approx 0.1N Ag nitrate. The carbide and phosphide material is obtd by hot w extraction of a 10g sample of the silicide, releasing these materials as volatiles into a carrier gas stream of N₂ gas which is then led into a series of receivers contg the Ag nitrate soln

- j - By measuring the vol of a 20g sample which has been compacted by jarring the contents 30 times

Table 2
Calcium Silicide, Granulation Requirements^a

Requirement	Type I	Type II	
	Min % by wt	Min % by wt	Max % by wt
Retained on 149 micron (No. 100) sieve	—	0	1
Passing 149 micron (No. 100) sieve	99.9	—	—
Retained on 105 micron (No. 140) sieve	—	0	1
Retained on 74 micron (No. 200 sieve)	—	6	12
Passing 62 micron (No. 230) sieve	65.0	—	—
Retained on 44 micron (No. 325) sieve	—	25	50
Passing 44 micron (No. 325) sieve	—	40	65

Footnote to Table 2:

- a - Gravimetrically by weighing the quantity of sample retained on each sieve of a nest of sieves after mechanically shaking and tapping the nest for 15 mins

Sax (Ref 10) compares Ca silicide to calcium hydroxide as a skin, eye and respiratory system irritant, and to the silanes as a great fire and explosion hazard. Ingestion of Ca silicide may cause death or permanent injury after very short exposure to small quantities

Cesium Silicide. CsSi; mw 161.0; solid-brittle brass colored compact mass; mp (vac) 350–60° (decompn to CsSi₈). Prepn is by heating finely ground Si with an excess of Cs in an autoclave type of app. The Si powdr is placed in a corundum crucible while the Cs is in an ampoule mounted in the top of the app. The syst is then evacuated and rinsed with argon, the Cs transferred from the ampoule into the crucible, and the mixt is then heated to 600° under a blanket of argon for 24 hrs and finally cooled to RT over a period of 48 hrs. The excess Cs is then vac-distd off at 150–80° over a period of four days (Ref 9, p 53). CsSi is v moisture sensitive and explds on contact with w or

dil acids. The silicide detons spontaneously with brisance in air (Refs 9, p 52 and 12, p 112)

Lithium Silicide. Li₆Si₂; mw 97.81; hygr, solid black crysts; mp (vac) 600° (decompn); d about 1.12g/cc. Insol in ammonia and turpentine (Ref 17). Prepn is by heating Si and an excess of Li in a Ni boat in vacuo for 2–3 hrs to a dull redness (500–600°). The excess Li is then removed using liq ammonia or distd off under vac at 400–500°. Li silicide forms spontaneously detonatable silanes on contact with w (Refs 9, p 51 and 12, p 112)

Magnesium Silicide. Mg₂Si; mw 76.73; slate blue cubic crysts; mp 1085°, 1102° (sep vals), (decompn at 550° in vac yielding Mg₃Si₂); d 1.94g/cc. Sol in concd acids and ammonium chloride. Prepn is by heating finely powdered Mg and Si together (in 20/6 proportions) in vacuo or an inert atm at a temp above 1000° (Refs 9, 14 & 17). CA Registry Nr [22831-39-6]. Mg silicide is vigorously decompd by contact with hot w or aq HCl yielding silanes which deton on contact with air (Refs 9 & 10). The silicide is suggested for use as a fuel and smoke producing agent in a pyrot patented by Lane and Smith (Ref 13)

Potassium Silicide. KSi; mw 67.20; poorly crystd, dark, hard, lustrous mass; mp (vac) 360° (decompn to KSi₈). Prepn is by passing K vap over Si heated at 650°. Excess K is vac distd off at 250° over a four day period (Refs 9 & 12). K silicide is spontaneously flammable with deton on exposure to moist air, w or acids (Refs 9 & 10)

Rubidium Silicide. RbSi; mw 113.55; small dark crysts; mp (vac) 350–60° (decompn to RbSi₈). Prepn is by the same procedure used for CsSi (above) except that reaction temp is 600° and the distn temp for removing excess Rb is 180–200°. The silicide explds on contact with w (Ref 9)

Sodium Silicide. NaSi; mw 51.10; long ndles with a metallic luster; mp (vac) 420° (decompn NaSi₈). Prepn is by the same procedure used for CsSi (above) except that the reaction temp is 700° and the distn temp for removal of the excess Na is 280–300°. Na silicide explds on contact with w (Refs 9, pp 52–54 and 12, p 113)

Refs: 1) W. Meyer, FrP 345049 & Addn 16460 (1912) & CA 7, 2475 (1913) 2) Anon, BritP

17583 (1915) & CA 11, 1751 (1917) 3) A. Segay, BritP 113083 (1917) & CA 12, 1252 (1918) 4) Ibid, USP 1280563 (1918) & CA 12, 2689 (1918) 5) E.I. Pronk & F. Bower, BritP 10865 (1915) & CA 13, 1460 (1919) 6) L. Médard, MAF 22, 601 (1948) & CA 44, 8657 (1950) 6a) A. Weale, "Priming Compositions for Percussion Caps", BritP 362048 (1930) & CA 27, 1177 (1933) 7) C. Belgrano, "Gli Esplosivi . . .", Hoepli, Milan (1952), 184-86 & 284 8) R. Sartorius, MP 34, 208-09 (1952) & CA 48, 11059 (1954) 8a) A.O. Franz, "Explosive for Oil-Well Gun Perforators and Ammunition Primers", USP 2708623 (1955) & CA 49, 14326 (1955) 9) G.V. Samsonov, "Silicides and Their Uses in Engineering", FTD-TT-61-409 (1962) 10) Sax (1968), 1089 11) W. Ripley, "Air and Water-Reactive Chemicals", RDTR 124 (1968), 72 12) J.R. Gibson, "Handbook of Selected Properties of Air- and Water-Reactive Materials", NAVAMDEP RDTR144 (1969) 13) G.A. Lane & W.A. Smith, "Pyrotechnic Smoke-Producing Compositions", USP 347134 (1968) & CA 72, 4848 (1970) 14) Merck (1976), 739 [Nr, 5515] 15) Anon, "Calcium Silicide, Technical", MIL-C-324B (2) (20 Aug 1976) 16) Anon, "Improvements in the Initiation of Explosives", BritP 1475044 (1974) & CA 88, 76102 (1978) 17) ChemRubHdbk (1978), B-101, B-126 & B-129 18) Anon, "Improvements in the Initiation of Explosives", BritP 1475044 (1977) & CA 88, 76102 (1978)

Silicominol. A variation of Minol in which powdered Si replaced powdered Al. The formulation contains AN 40, TNT 40 and Si 20%. The refs contain the results of bullet impact sensitivity tests. See also under "Minol" in Vol 8, M135-R to M143-R

Refs: 1) Anon, "Sensitivity of Explosives to Projectile Impact", OSRD 3156 (1944), Appendix A 2) D.P. MacDougall et al, "Physical Testing of Explosives", OSRD 5745 (1945)

Silicon and Derivatives

Silicon. Si; at no 14; at wt 28.086; valences +2 and +4; three stable isotopes; octahedral form is dark-colored (steel grey to blue) friable platelets; amorph form is minute dark brown needle-like crystals; mp 1410°, 1423° (separate values); bp 2355°, 2630° (separate values); d 2.32-2.34, 2.4g/cc (separate values). Sol in a mixt of HF+HNO₃ or in NaOH soln or in molten alkali oxides; insol in w and HF. CA Registry Number [7440-21-3]. Si makes up 25.7% of the earth's crust by wt, being found in nature as either silica or silicate. Comml prepn of pure Si consists of heating sand with coke in an electric furnace. Ultra high purity Si is achieved by the distn of Si tetrachloride, tetraiodide or silane, then reduction to Si with ultra pure Zn followed by vacuum or argon zone refining (Refs 5, 9a, 35, 37 and 38). Si burns spontaneously in fluorine and chlorine. It has a ΔH_f° of 88.04 kcal/g-mole. Ign temp in air of Si powder, of which 86% passes thru a number 270 mesh (53 μ m) sieve is 775°. Material finer than this (dust) is spontaneously air flammable (Refs 9a, 29, 37 and 38). When heated, Si can react with w or steam to yield hydrogen or with oxidizing materials to produce an exothermic reaction (Refs 1, p 116 ff and 6, p 1089)

Successful experimentation has been conducted by Dutta (Ref 34) in the use of Si with 20 wt % B₄C to evolve a low d alloy which can act as personnel armor by providing protection against fragments and small-arms ball projectiles comparable to that of hot-pressed B carbide. The most promising fabrication techniques investigated were hot pressing and liq phase sintering. The hot pressing temp for Si-20 wt % B₄C is 1440°, and the liq-phase sintering temp is 1520°. Dutta also reported that cold forming of flat plates and complex shapes from the alloy had been successfully achieved by a slip casting process

The use of Si in *electronic* devices such as Si controlled rectifiers (SCR) is worthy of mention because electronic devices are used extensively in ballistics and other branches of ordnance. According to Cassidy (Ref 25), SCR can be used as fast, high current switching devices in systems required to be capable of

operation after exposure to nuclear radiation. SCR, with careful selection, will survive neutron dose levels up to $2 \times 10^{13} \text{ n/cm}^2$. Cassidy also reports that if operation is required during radiation exposure some measure of "hardness" to transient radiation can be achieved by lowering the value of the gate-to-cathode resistor in the SCR circuit. For more information on the use of Si in electronic devices see in the references listed under "Electronics" in Vol 5, E74-L and R

The use of Si in *energetic materials* is a subject of some importance. In such use Si acts as a high energy fuel that generates and maintains large amts of thermal energy in conversion to the oxide (Ref 7, p 327). An early expl patent of interest is that of Unger (Ref 2), who suggested that Si be incorporated in a blasting formulation consisting of AN (50–85), Si (10–40) and NG (gelatinized with NC)(1–15p). In a study conducted by Sartorius (Ref 4), the use of Si as a replacement for Al in expls was investigated by the incorporation of 5–20% of 96.5 to 97% pure Si in PETN, RDX, Tetryl, PA and TNT. It was found that this addition increased the avg power (Pb block expansion) over the pure expls by 5.96%. The Si addition to RDX and PA decreased the avg deton vel by 2035m/sec (30.31%). Sartorius also found that in lab mixts of AN and TNT addition of Si decreased the sensitivity to shock. It was also found that powd Si did not react with w at RT to release hydrogen. The exptl series continued with an investigation of the value of Al which, when similarly incorporated into the same series of expls as Si, was found to increase the power over that of the (pure) expls by an avg of 16.04%. Sartorius concluded that for the same percent addition, the specific work increase (power) to be expected from the use of Si in expls was 1/2 to 2/3 that of Al. Sartorius also derived a thermodynamic equation to predict the percentage increase in Pb block value produced by a 1% addition of any metal to an expl that is slightly oxygen deficient with a "potential" Q of 1000 cal/g:

$$\text{Index of Activity} = (q/M) - (34V/M) - 1.3$$

where: q = heat of oxidation in cal/mole

V = valence of the metal

M = molecular wt of the metal

The activity index of metals calcd using this

equation is as follows: Li 14.3, Be 6.1, Al 2.0, Mg 1.9, Na 1.6, Si 1.1, La 0.9, Ca 0.8, Ti 0.4, K 0.0, Zr -0.9, Zn -1.0, Sn -1.3, Fe -1.4, Pb -1.4 and Cu -1.8

The most current work in the area of expl phenomena which include Si involves aerosols in which finely divided alloys of Si are dispersed. The work of Mukhametov (Ref 13) in the area indicates that the lower expln limit for Cu-Si alloy aerosols in air is 394 g/m^2 with a 90.4% Si alloy. Popov et al (Ref 14) also published a study in which he spark-detonated Al-Si alloys (19.1 and 80.5% Si) having a 56 micron particle size which were dispersed in an aerosol. It was found that the lower expln limits of these alloys were 44 g/m^2 for the 19.1% Si concn and 800 g/m^2 for the 80.5% Si concn

In proplnts the most current usage for Si is suggested in the patent of Shiki and Harada (Ref 25a). Here Si is used as a fuel in proplnt compns which are used to generate a gas for inflation of impact-protective gas bags in automobiles during a collision

The field of pyrots presents, by far, the widest usage of Si. Its use includes ignition compns, delay trains, variations of the thermite processes, and mass-produced ordnance items such as hand grenade fuzes. Its long usage in pyrots is occasioned by the facts that it is abundantly available, chemically stable, inexpensive and very safe to handle (Ref 7, p 327). Ellern (Ref 7) lists six starter mixts or hot first fire compns (Formulas 166–172, pp 379–80) based on Si as a fuel of high heat output and high heat retention. Typical formulations (Formula 166, p 379) include Si (40.0), K nitrate (54.0), and charcoal (6.0%); or (Formula 172, p 380) Si (50), Pb dioxide (20), and Cu oxide (30%). The latter formulation has a calorific output of 380 cal/g and an ignition pt of about 500° (Refs 5a & 9). Si was used in early delay compns with red Pb and Pb chromate (Refs 3 & 7, p 197), or with only Pb dioxide (Ref 10). Again, according to Ellern (p 227), Si has been mixed with Al, sand and salt-type oxidizers to provide the pyrochemical heating required to prolong the molten state of a metal before and after pouring. In this instance contamination is tolerated if the additives float as a slag on top of the metal. Additionally, Si has been suggested for the "thermite" process as a

reducing additive (Ref 7, p 246). A search of the current pyrot literature has revealed the following usage for Si; the patent of Bouisse and Villey-Desmescrets (Ref 15) suggests that Si be part of a compn [consisting of black FeO (84), Al powder (13) and Si (18 parts)] which will heat to incandescence a radiating plate (of Mo or W) mounted within the base of a projectile in such a manner as to be visible during flight. The incandescent plate acts as a visible light tracer element and also serves to ignite the other visible light output pyrot compn elements contained within the base of the projectile. Gawlick et al (Ref 17) have proposed a technique for the rapid heating of a substance within 3 secs to 650° and maintaining it within $\pm 30^{\circ}$ of 650° for 3 mins using two separate Si containing mixts. The initiator compn contains K dichromate (26), Si powd (39) and Pb dioxide (35%). The main charge compn consists of a 40:60 K dichromate-Si powd which is used to maintain the temp. Lohkamp's patent (Ref 20) describes a pyrot candle which when burned will produce IR radiation in the 0.74 to 1.2 micron region of the spectrum with little visible light emission. The suggested compn consists of Si, hexamethylenetetramine, an epoxy binder and an alkali metal nitrate (mixt) of Rb nitrate and/or Cs nitrate. Lipscomb (Ref 24a) investigated the heat of combustion of two lattice types of Si, n-type and p-type, using a Parr Oxygen Bomb Adiabatic Calorimeter with a blanket of argon to measure the values resulting from the reaction, Pb oxide + Si \rightarrow Si oxide + Pb. He found that n-type Si is the more reactive form and has the higher heat of reaction. Some useful information in the thermal physics and chemistry of Si-containing delay compns has been reported by Howlett and May (Ref 26). They investigated the B-Si-K dichromate pyrot delay system and concluded that ignition of the system is dependent on thermal transport in the liq phase; hence, the combustion zone propagates as a molten front. This is contrary to such systems as the B-PbO system which show ignition and combustion in the region of oxidant fusion. A Nobel (company) patent (Ref 27) suggests that Si be included in a compn useful for signalling, illumination or smoke generation. The formulation consists of MnO₂ (83), Si powd (15) and Portland cement (2 wt %), which is made into a

paste with w and molded in a cardboard tube 38mm in diameter and 40mm long. The dried solid cylinder on ignition is reported to have burned for approx 20 secs. By adjusting the proportions of the mixt to 68:12:20 the burning time was extended to 80 secs. The Purto et al (Ref 32) patent suggests that Si be added in the form of a Si-Ca mixt to a red color fireworks display or pyrot signal to produce a blue luminescence. The suggested addition includes 10–30% Si-Ca alloy in the form of 0.5 to 0.8mm grains and 0.5 to 1.5% fluorine-containing rubber (SKF-32). For more information on Si in pyrots see Vol 8, P506-L under "Table I - Infrared Flare Formulas . . ." and "Flare Formulations"

The US military specification (Ref 8) has the following chemical (Table 1) and granulation (Table 2) requirements for Grade I (with 3 classes; A, B and D) and Grade II (with one class; C) silicon:

Table 1
Chemical Requirements

Requirements	Grade I	Grade II
Silicon, min % by wt ^{-a}	97.0	96.5
Iron, max % by wt ^{-b}	1.00	—
Aluminum, max % by wt ^{-c}	1.00	—

Footnotes to Table 1:

- a - Gravimetrically as SiO₂ (by difference) after alkali fusion of a 0.5g sample, leaching with HCl and hot w, filtering off of the HCl insolubles, drying and weighing the SiO₂ residue to 0.1mg. Solution, and oxidation of the SiO₂ residue with sulfuric and HF acids, and, finally, volatilization of the Si fluoride by ignition, then cooling and weighing
- b - By redox titrimetry using 0.1N K permanganate titrant on the ferrous sulfate residue remaining after alkali fusion and HCl leaching of a 0.5g specimen (see footnote "a", above), followed by K persulfate reduction of the ferric ion
- c - By calculation after separation and weighing of both the iron and aluminum as their oxides from a 0.5g specimen and subtracting the wt of the iron oxide determined as iron in footnote "b", above

Table 2
Granulation Requirements

US Standard Sieve Size	% by Wt Passing Thru			
	Class A ^{-a}	Class B ^{-a}	Class C ^{-b}	Class D ^{-a}
149 micron (#100), min	99.0	—	—	99.0
88 micron (#170), min	—	—	98.0	—
74 micron (#200), min	80.0	99.9	—	—
62 micron (#230), min	—	—	90.0	50.0

Footnotes to Table 2:

- a - Gravimetrically by weighing each sieve of the nest of sieves shown in the table after shaking a 100g specimen thru the nest by means of a mechanical shaker which produces 300 ± 15 gyrations and 150 ± 10 taps of the striker/min for 5 mins
- b - Gravimetrically after first washing a 50g specimen thru a 62 micron sieve with w and drying at $105-20^\circ$ for 30 mins, then proceeding as in "a", above

The toxicity of Si according to Sax (Ref 6, p 1089) is unknown. However, the tolerance level shown in the "Condensed Chemical Dictionary" (Ref 37, p 774) is $10\text{mg}/\text{m}^2$ of air. The same caution one would take in the manuf or handling of silica (qv) or any of the silicates (qv) should be similarly used with Si

Silicon Carbide. See in Vol 1, A79-L & R. Also the following *Addnl Refs* (the numbers indicate the appropriate refs listed at the end of this article on "Silicon and Derivatives"):

3a) [The "Handbook of Japanese Explosive Ordnance" indicates that SiC was used in Type 4 expl (see in Vol 7, J56-L) and Type 88 expl (see in Vol 7, J57-L) as a means of uniformly propagating the detonation wave thru the loosely packed powder]; 11) [The patent of Lane and Smith suggests that SiC be used as a fuel in a pyrot smoke-producing compn]; 21) [The first of a three-volume document describing the fabrication, development and evaluation of co-deposited pyrolytic graphite-silicon carbide (PG/SiC) coatings on graphite substrates for rocket nozzle application. Vol I covers both thermal and mechanical properties of PG/SiC codeposit. It was found that the coating is nearly isotropic with respect to thermal expansion and elastic

thermal conductivity]; 22) [In Vol II of the series (see above ref) parameters were established to vapor deposit PG/SiC coatings on components for nozzles with throat diameters up to 1.7 inches]

Also, *Limited Distribution Addnl Refs* A and B

Silicon Dioxide. See in Vol 8, O49-R to O50-R

Silicon-Ferro Alloy. See in Vol 6, F16-R to F17-L under "Ferrosilicons", and the following *Addnl Refs* (The numbers indicate the appropriate refs listed at the end of this article):

2a) [Tissell's patent suggests that ferrosilicon be included in expl formulations such as Al (2-3); ferrosilicon (6-9); wood powder (cellulose or C) (9-13); nitrobenzenes or nitrotoluenes (8-15); Na, Ba or Sr nitrates (25-35); Amm Perchlorate (35-55); and paraffin or wax (2-15p). Colloid may be incorporated to gelatinize the nitro-compds]; 12) [Shinohara and Oishi's patent suggests that ferrosilicon be used as a fuel in a liq expl compn which may consist of a 1:1 mixt of DNT-dinitroxylyene (10), AN (69.9), a non-ionic surfactant (0.1), ferrosilicon (10), and w (10%). The compn has a d of $1.45\text{g}/\text{cc}$ and a detonation rate of $4500\text{m}/\text{sec}$; 40g of Dynamite is used as the primer]; 18) [Neikov et al detd the explosiveness and the expl parameters of ferrosilicon powder in a static expln chamber (Table 1)]; 19) [Sulacsik found in pyrot mixts of MnO_2 plus ferrosilicon (10/90) that the most violent reaction occurred in mixts contg 72.8% MnO_2 with a duration of 3.5 mins. This mixt has a negative oxygen balance and the lowest heat of reaction of all the ratios examined. The data was obtained using TGA and DTA techniques]; 23) [Bunchev reports on Bulgarian mining expls contg TNT, AN or Na nitrate, a gelatinizing mixt and ferrosilicon powder]; 30) [The patent of Fujiwara et al suggests that ferrosilicon can be used to increase the stability of liq expls. The following compn was fabricated and detonated; 30 wt p of powdered K perchlorate and 30 wt p of powdered ferrosilicon were added to 50 wt p of an 85% aq urea perchlorate sol to obtain a slurry-like expl with a d of $1.7\text{g}/\text{cc}$ and a deton vel of $3700\text{m}/\text{sec}$; it also demonstrated high stability]

Table 1

Ferrosilicon Powder Explosion Parameters (from Addnl Ref 18)

Silicon Concn, %	Particle Size Distribution, microns	Self-Ignition Temp, °	Lower Explosion Limit Concn, g/l	Max Press of Expl Mixt, kg/cm ²	Rate of Press Increase, kg/cm-sec
65	≤50	None	0.4	0.4	0.6
75	natural distribution	—	0.6	0.64	7.0
75	<50	—	0.15	3.5	35

Silicon Fluoride or Silicon Tetrafluoride. See in Vol 6, F146-R to F147-L, and G100-L under the history of NG manufacture where the use of SiF₄ to separate the liq phases and recover the NG is discussed

Silicon Fluorodinitro Compounds. Silane esters of 2,2,2-fluorodinitroethanol have been prep'd from chlorosilanes in approx 90% yield by Neale and Williams (Ref 36). A typical example of one of the silanes fabricated and examined in this ref is

Dimethyl (Bis-2,2,2-Fluorodinitroethoxy Silane. [FC(NO₂)₂CH₂O]₂Si(CH₃)₂; mw 317.268; OB to CO₂ -35.30%; mp 19-19.5°; bp 96° at 0.1mm; d 1.395g/cc at 24°; RI 1.4308 at 22°. Sol in dimethoxyethane. The silane is hydrolyzed very slowly in air at 52% RH. Prepn is by reaction of 0.06 moles of fluordinitroethanol with 0.03 moles of dimethyldichlorosilane at 60-80° for 3 hrs with stirring under a blanket of dry nitrogen gas. The product is then dist'd thru a micro Vigreux column under reduced press. The yield is 87% of a 97% pure product. The shock sensitivity reported by the authors is approx 300kg-cm with the following note ". . . ASTM procedure No D2540 for liquids, except with unsealed sample container; value reduced to only 2.5kg-cm under the usual compressive shock conditions (sealed sample cup). M. Kamlet, AWRE test for solids, sandpaper surface; value approx 300kg-cm in ASTM test apparatus with unsealed sample cup . . ."

The authors calcd the following max expl parameter values: ΔH_f is 288kcal/mole; Q is 1310cal/g; detonation pressure is 153kbars; and detonation velocity is 6.38km/sec

Silicon Nitride. Si₃N₄; mw 140.31; grey-white amorph powd; mp 1900° (sublimes); d 3.44g/cc. Sol in HF acid. Prepn is by reaction of powd Si and nitrogen in an electric furnace (Refs 1, 37 and 38). Si nitride is used as an ablative material in rocket nozzles (Ref 37); the material fabricated by a reaction sintering process is used in radome applications (Ref 24) and a current usage in expls involves those containing electrically conductive compds. For these compns the patent of Harris and Martin (Ref 33) suggests that the incorporation of 5-20% of the nitride raises the electrical power dissipation threshold of the expl compn and improves its resistance to radiofrequency hazards

Silicon Tetrazide. See in Vol 1, A597-R

Written by H. L. HERMAN

Refs: 1) Gmelin, Syst No 15, Teil B (1959), 1 ff 2) N.A. Unger, USP 1566784 (1926) & CA 20, 505 (1926) 2a) C.L. Tissell, BritP 116890 (1918) & CA 12, 2443 (1918) 3) O.E. Burton, "Development of a Lead-Chromate-Silicon Powder Burning in 30-35 Seconds in the 21-Sec 1907M Time Fuze", PATR 185 (1932) 3a) Anon, "Handbook of Japanese Explosive Ordnance", OPNAV 30-3M (1945) 4) R. Sartorius, "A Study of the Possible Use of Silicon in Explosives", Translated by H.W. Adam & O.E. Sheffield, PACRS, from MP 34, 205 (1952) & CA 48, 11059 (1954) 5) G. Brauer, Ed, "Handbook of Preparative Inorganic Chemistry", Vol 1, 2nd Edn, Academic Press, NY (1963), 676-79 5a) W. Ripley, "Investigation of the Burning Characteristics of the Lead Dioxide-Cupric Oxide-Silicon Starter Composition", NAVAMDEP RDTR41, Crane (1964)

- 6) Sax (1968), 1089-90 7) Ellern, "Pyrotechnics" (1968), 193, 197, 227, 240, 246, & 326 ff 8) Anon, "Silicon Powdered, Technical", **MIL-S-230B** (1969) 9) W. Ripley, "Effect of Sample Holder Geometry on Pressure-Time Curves of Lead Dioxide-Cupric Oxide-Silicon Starter Composition: A New Test Fixture Design", NAVAMDEP **RDTR142**, Crane (1969) 9a) J.R. Gibson & J.D. Weber, "Handbook of Selected Properties of Air- and Water-Reactive Materials", NAVAMDEP **RDTR144** (1969), 22 10) J.H. M. Mclain, "Heats of Reaction Plots as Design Criteria for Pyrotechnic Reactions", USClearinghouseFedSciTechInform, **AD1968**, 293-303 & **CA 72**, 14364 (1970) 11) G.A. Lane & W.A. Smith, "Pyrotechnic Smoke-Producing Compositions", USP 3471345 (1969) & **CA 72**, 4848 (1970) 12) M. Shinohara & K. Oishi, "Explosive Compositions", JapP 6905720 (1969) & **CA 72**, 4844 (1970) 13) M.M. Mukhametov, "Lower Concentration Limit of the Explosiveness of Aerosols of Alloys", TsvetMetal(Russ) **1970**, 43 (9), 62-63 & **CA 74**, 44823 (1971) 14) V.G. Poyarkov & E.I. Popov, "Explosiveness of Aluminum-Silicon Aerosols", FizAerodispersnykhSist **1970**, No 2, 135-42 (Russ) & **CA 74**, 77809 (1971) 15) J.M. Bouisse & F. Villey-Desmeserets, "Pyrotechnic Tracer for Projectiles and Missiles", FrP 1601136 (1970) & **CA 74**, 89334 (1971) 16) no ref 17) H. Gawlick et al, "Rapidly Heating a Substance to, and Maintaining it at or in the Region of an Elevated Temperature", BritP 1203782 (1968) & **CA 77**, 77348 (1972) 18) D.D. Neikov et al, "Explosiveness of Ferrosilicon . . . Silico-calcium . . . Powders", PreduprezhdenieVnezapnykhVzryvovGazodispersnykh (Russ), 36-44 (1971) & **CA 77**, 167641 (1972) 19) L. Sulacsik, "Thermal Analysis of Pyrotechnical Mixtures. I. Mechanism of the Reaction Manganese + 10 Iron-90 Silicon", JThermAnal **1973**, 5 (1), 33-42 & **CA 78** 126453 (1973) 20) C.W. Lohkamp, "Near Infrared Illuminating Composition", USP 3733233 (1973) & CA, not found 21) R.H. Singleton, "Development and Evaluation of PG/SiC Codeposited Coatings for Rocket Nozzle Inserts", Vol 1, "Thermal and Mechanical Properties of PG/SiC Codeposits", **AFRPL-TR-73-70** (1973) 22) J.W. Murray et al, Ibid, Vol II, "Thermostructural Analyses of Selected Nozzle Test Firings", **AFRPL-TR-73-107** (1974) 23) G. Bunchev, "Mass and Efficient Use of New Explosives in Bulgarian Open Mines", Rudodobiv (Bulg) **6**, 12-16 (1972) & **CA 80**, 61668 (1974) 24) D.R. Messier & P. Wong, "Silicon Nitride: A Promising Material for Radome Applications", **AMMRC-TR-74-21** (1974) 24a) C.A. Lipscomb, Jr, "The Chemical Effects of Doping on the Litharge Silicon System", NAVAMDEP **RDTR264**, Crane (1974) 25) E.I. Cassidy, "Nuclear Radiation Testing of Diodes, Silicon Controlled Rectifiers, Transistors and Integrated Circuits", **PATR 4692** (1974) 25a) T. Shiki et al, "Gas-Producing Mixture", GerP 2410093 (1974) & **CA 82**, 75158 (1975) 26) S.L. Howlett & F.G.J. May "Ignition and Reaction of . . . Boron-Silicon-Potassium Dichromate Systems", Thermochemica-Acta **9** (2), 213-16 (1974) & **CA 82**, 75111 (1975) 27) Anon, "Pyrotechnic Composition", GerP 817842 (1973) & **CA 83**, 30480 (1975) 29) E.G. Kayser & C. Boyars, "Spontaneously Combustible Solids - A Literature Survey", **TES-20-75-1** (1975), 20 30) S. Fujiwara et al, "Explosive", JapP 7413813 (1973) & **CA 83**, 100319 (1975) 31) Anon, "Silicon, Lump (Foundry)", **QQ-S-351B** (1975) 32) Yu.I. Purtov et al, "Pyrotechnic Composition of Red Fire", RusP 498276 (1974) & **CA 84**, 124136 (1976) 33) R.C. Harris & J.W. Martin, "Improvements in or Relating to Explosive Compositions", BritP 1451441 (1976) & **CA 86**, 92718 (1976) 34) S.K. Dutta, "Various Methods of Processing Silicon-Based Composites for Armor Applications", **AMMRC-TR-76-21** (1976) 35) Merck (1976), 1099 (Nrs 8233 & 8234) 36) R.S. Neale & T.C. Williams, "Fluorodinitro Silicon Compounds . . .", Union Carbide Corp, Tarrytown, ONR Contract N00014-75-C-0791 (1977) & **CA 87**, 154290 (1977) 37) Cond-ChemDict (1977), 774 38) ChemRubHdb (1978), B-155 & D-75
- Addnl (Limited Distribution) Refs:* A) M.C. Hughes et al, "Codeposited PG/SiC and PG Nozzle Liners for Advanced ICBM Systems", **AFRPL-TR-75-22** (1975) B) P.A. Tomlinson et al, "Development of Graded PG/SiC Coatings for Rocket Nozzles", **AFRPL-TR-75-72** (1976)

Silicones

See under "Siloxanes" in article on "Silanes" in this Vol for the definition and a brief description of the basic molecular structure. The name "silicone" was created by F.S. Kipping as an analogy to ketones. However, his "silicane-diols", $(\text{Aryl})_2\text{Si}(\text{OH})_2$ could not be dehydrated to "silicones" but always condensed to higher mw Si-O-Si compds. These structures were then (early 1900s) referred to as *silicones*. In time the name has come to represent *any* organo-silicon oxide polymer, such as polydimethylsiloxane (see below):

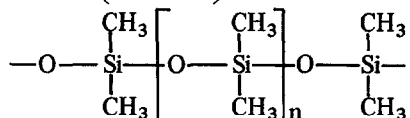

Any monovalent organic radical can be substituted for any or all of the methyl radical (s) shown in this example structure. Physical properties depend on the size and type of radical (methyl, phenyl, etc), the radical, Si ratio, and the molecular configuration of the polymer (linear, cyclic or crosslinked). Crosslinked polymerization can be accomplished using benzoylperoxide or other free radical initiator, with or without a catalyst. The resulting compd can be a liq, a semisolid or a solid depending on mw and degree of polymerization. Hence, viscosity ranges from one to over a million centistokes. Polymers exhibit stability over temp ranges of from -50 to $+250^\circ$, excellent dielectric properties, and permeability to gases. Other properties are low surface tension (liquids), extreme w repellency and high lubricity. Silicones are sol in most organic solvents. The unhalogenated silicones are combustible. Prepn is by heating Si in methyl chloride to yield methyl chlorosilanes which are subsequently separated and purified by distn. Polymerization is accomplished by mixing the desired compd with w. Another prepn consists of reacting silicon tetrachloride and a Grignard reagent (organic radical -Mg-Cl structure), with subsequent hydrolysis and polymerization. An excellent article by Lichtenwalner and Sprung (Ref 13) contains information in depth on the prepn, properties and comml uses of silicones. Also see Refs 1, 2, 2a, 35 and 39

A search of the current open literature has re-

vealed widespread successful experimentation useage of silicones in energetic materials. An interesting piece of work in *detonation thermodynamics* is that of Ornellas (Ref 26). He used a detonation calorimeter to det product compns and heat releases representative of the isentropic expansion of the detonation products of a CHNOSi system, namely, XTX-8003 (a compn developed by Los Alamos Scientific Lab) which is comprised of PETN (80) and silicone potting compd ($\text{C}_2\text{H}_6\text{OSi}$) (20%). The following table presents the results of this investigation (Ref 26, p 40)

Table 1

The Heat and Products of Detonation of Heavily Confined Charges of XTX-8003^a

d, g/cc	1.55
Charge weight, g	22.8
ΔH , cal/g	1160 \pm 15

Amount of Product, mole/mole of Explosive

CO ₂	0.41
CO	1.07
C _(s) ^g	0.26
N ₂	0.43
H ₂ O	1.01
H ₂	0.49
NH ₃	0.076
SiO ₂	0.27 ^{-b}
CH ₄	0.063
C ₂ H ₄	not detected
C ₂ H ₆	0.002
HCN	0.001

Footnotes to Table 1:

- a - Cylindrical charges, 1.27cm in diam, completely confined in 1.27cm thickness of gold. Corrected for PETN in the initiation system
 b - From total silicon contained in the explosive

In the area of *expls*, information on plastic-bonded expls incorporating silicones can be found in Vol 8, P60-L to P77-L under "PBX"; also, in this Vol see under "RIDE", where a uni-temp silicone grease is used as a constituent of this compn. The patent of Stott et al (Ref 21) claims that by using a silicone resin as a binder-fuel, a compressible expl is produced which is insensitive and heat- and solvent-resistant. Thus, a soln of 91g of "Viton" (a DuPont Co fluorelastomer - Ref 39, p 921) in 1000ml of acet and 460ml of a soln of 23g "Chemlock"

(a Hughson Chemical Co adhesive containing 0.1 to 2.5% silicone resin — Ref 39, p 188) in methanol are stirred into 2157g of diamino-trinitrobenzene for 45 mins, 25 lbs of w is added and the product is recovered from the slurry formed. The product is then dried at 80° and press loaded at 135° and 20000 psi using a 5-min dwell time. The expl pellets formed are ejected at RT. Stott et al reported the following parameters of this expl: an autoignition temp of 303–06°, a compressive strength of 14300 psi, a detonation rate of 7295m/sec, a thermal transition temp of 275–85°, and a vacuum stability at 120° and 200° of 0.2 and 3.0ml of gas/g in 48 hrs, respectively

The patent of Fujiwara et al (Ref 32) suggests that a silicone oil mixt be used as a waterproof barrier for underwater blasting using a liq expl. To demonstrate the underwater effectiveness of their invention the patentees used a reinforced concrete block of approx 260kg/cm² compressive strength contg a drilled hole. The block was placed 1.5m deep in w and the hole then charged with 30ml of 40:60 carbon tetrachloride-silicone oil mixt (d 1.24g/cc, viscosity 25cP) thru a tube extending to the bottom of the hole. A 13:9:78% mixt of N₂H₄-w-Hydrazinium Nitrate (d 1.41g/cc) was then added in a similar manner. A floating electric blasting cap — primer designed to float in the charge cap — was then used to detonate the charge which completely destroyed the block

The patent of Martel and Le Du (Ref 33) claims that the effect of solid phase change with temp variations in solid expl compns is minimized by the prepn of a granular product comprising a particulate high expl such as HMX coated by conventional methods with a mixt of a thermosetting resin such as a silicone elastomer and crosslinking agents, and organometallic or tert-amine catalysts which are activated only at temps above the softening pt of the resin. In use, the expl compn is either cold-compressed or isostatically molded and then heated to the required crosslinking temp. Thus, a soln of carboxymethylcellulose and 28% aq amm hydroxide, 1 g each, in 100ml of distilled w is added in a fine stream to a vigorously agitated soln of 30g of the silicone elastomer and 3g of oleic acid in 100ml of ethyl acetate, after which 130ml of distd w is added. The resultant emulsion is added to a vigorously stirred suspension of 92g

of HMX and 0.5g of graphite in 500ml of w. The emulsion so obtained is broken by the addn of a 10% soln of electrolyte [Al₂(SO₄)₃] to form a granular product. The product is then dried and treated with a soln of a crosslinking catalyst (an organo-Sn compn). After solvent removal, the recovered granules are compression-molded and held at 50° for 20 hrs to provide (it is claimed) cured cylinders having both good mechanical and storage properties

In another patent, that of Kehren and Ousset (Ref 38), it is claimed that the addn of ≤ 2 wt % of a heat hardening silicone resin as a binder to a pressure-formed expl compn will provide thermal stability. The patent of Falterman and Sbrocca (Ref 41) suggests that the thermal stability, shrinkage and crack resistance of plastic-bonded HMX expls are so improved by the addn of silicones that large missile warheads can be cast without cracking. Thus 45g of "Sylgard" (a silicone resin with a base of polydiethylsilicate — a product of Dow Corning Corp) and 225g of HMX are mixed for 35 mins, vibration cast and cured. The properties of this compn compared to two polyester-bonded compns are shown in Table 2

Statesir found in a hazardous reactant study (Ref 20) that Cl will react explosively with silicone oils in a high pressure environment. Work on the *impact sensitivity* of silicones such as silicone rubber, fluorinated silicone and chlorotrifluorocarbon plastic silicone in liq and gaseous O₂ by Key (Ref 16) is pertinent. Here it was found that the impact sensitivity varied inversely with sample thickness in both liq and gaseous O₂. However, in gaseous O₂ the sensitivity varied directly with pressure and was more pressure dependent in gaseous O₂ than in liq O₂. The relative rating of samples tested in liq O₂ at $\approx 6.8 \times 10^6$ Newtons/cm² was the same as liq O₂ at 9.5×10^6 Newtons/cm² using an impact sensitivity tester described in **ASTM D2512** with a pressurized sample holder. Holovka (Ref 40) studied the effects of expl binder interactions on the *viscoelastic* properties of PETN/- and RDX/"Sylgard-182" (a Dow Corning Corp product) formulations using a free torsional pendulum. Both materials exhibited viscoelastic properties typical of elastomers. The PETN formulation showed a weak phase transition at -100° and a strong one at 130° with a glass transition temp at approx 30°. The RDX formu-

Table 2
Properties of Plastic Bonded HMX

Properties	Sylgard-HMX	PBXN-101 Polyester-HMX	PBXC-113 Plasticized Polyester-HMX
Autoignition Temp, °C	248	237	242
Cycling to 300°F (Time in hours) held	10	3	10
% Density loss	0	0.06	1.0
Density, g/cc	1.67	1.67	1.70
Detonation Velocity, m/sec	7760	7900	8060
% Shrinkage	0.2 or less	2	1-1.5
Bolt cracking test	No cracks	cracks	slight cracks

lation showed phase transitions at 150° and -60°. Holovka concluded that the higher glass transition for the PETN formulation may be due to intermolecular bonding between the expl and silicone binder

Advances in the field of *propants* using silicones have been the objective of more than several studies and patents. Ender's patent (Ref 5) suggests that the coating of AN with a siloxane and subsequent mixt with organic polymeric fuels will produce storage-stable, void and crack-free mechanically strong solid propants. Thus, a mixt of 10g of 30-325 mesh AN and 0.2g vinyltriethyloxysilane in 15cc benz is ball-milled for 15 mins. The benz is then evapd by using air with an RH of 60%, which also oxidizes the silane. The mixt is then heated for 10 mins at 100° to give AN coated with a siloxane composed of $[\text{CH}_2:\text{CHSiO}]_{1.5}$ groups. A desired propant is then prepd by suspension of 50p AN (coated with 0.5p siloxane) in 100p molten asphalt. Hammond et al (Ref 12) studied the effect of addition of the siloxane group into polyurethane propant binders on the burning rate. They prepd Amm Perchlorate-based propants using 1,3,5,7,9,11-hexaphenyl-5,11-dihydroxytricyclo [7,3,1,1] hexasiloxane (Dow Corning Corp's Z-6018) as a copolymer. The siloxane group added 2.07% Si to earlier non-Si contg propant formulations, which served to increase the burning rate from 0.2inch/sec to 0.575inch/sec at 1000lbs/inch². Hallstrom's patent (Ref 17) suggests that silicone rubber be used as a fuel along with a fluid amine such as N-tetramethyl-1,2-diamino ethane for hybrid

rockets, with nitric acid as the oxidant. The liq amine is stored aboard the rocket by swelling (or soln of) the elastomer to a predetd vol

A patent assigned to Nitrochemie G.m.b.H. (Ref 18) claims that the addn of 0.3 to 5% polysiloxane to a solid Amm Perchlorate-based propant with a polyurethane or polybutadiene binder markedly increases the burning rate. The patent assigned to the Société National des Poudres et Explosifs (Ref 23) suggests that a solid propant can be *inhibited* (see Vol 7, I102-L ff under "Inhibiting of Solid Propellant Grains") by coating it with a silicone-based inhibitor varnish comprised of a silicone elastomer, silicone polymerization catalyst and a glass bead filler. Another patent in the same vein is that of Hacket et al (Ref 34) which claims that a shroud of Fiberglas impregnated with silicone rubber covering a propant charge will inhibit the charge so that it will not distort in storage, and upon combustion the shroud will not disintegrate into particles of sufficient size to block gas exit ports. Green's patent (Ref 24) claims that by addn of a carboranyl siloxane to the fuel-binder of an Amm Perchlorate-based propant, a solid propant is produced having a high and stable burning rate, good mechanical properties, safe handling characteristics and use over a wide range of combustion chamber pressure. Thus, equimolar amts of 1-(methyldiethoxyymlyl-4-butyl) carborane and dimethyldichlorosilane are refluxed for 36 hrs in anhyd benz in the presence of catalytic amts of ferric chloride. The solvent is then stripped and the residue washed and dried. The viscous liq (mw 2286) is then

heated to 50° and mixed (9.5p) with 300–800 micron Amm Perchlorate (68.6p), isopropyl-carborane (9.5p), approx 40-micron Al (11p), lecithin (1 p) and Kosmos C black (0.4p by wt). The mixt is then pour-cast and cured to produce proplnt grains with burning rates of 1.75 and 3.19 inches/sec at 500 and 1000 psi, respectively. Green also reports the burning rate equation exponent to be 0.86 in the 600–1000 psi range

Loftus et al conducted a liq proplnt improvement program (Ref 25) for Bell Aerospace Co under the auspices of the Air Force Rocket Propulsion Lab, Edwards AFB, Calif, to determine the best silicone additive for use with unsymmetrical dimethylhydrazine (UDMH), monomethylhydrazine (MMH) and their 50:50 mixt on the basis of solubility, stability (48-hr temp stability), storage (30-day), physical and thermal properties of the fuel blends, and engine performance (using N_2O_4 as the oxidizer) parameters. The authors found that UDMH is the best solvent for the 132 silicone compds tested. They also reported that the heat transfer tests, utilizing resistance-heated circular tubes, showed that the nucleate boiling range of the 50/50 fuel blend was significantly extended with the addn of a 2% silicone additive. UDMH and MMH fuel heat transfer characteristics were unaffected by silicone additives. Engine fire tests results were also reported from the testing of the N_2O_4 –50/50 blend. They indicated a 42% reduction in throat heat flux when 1% silicone was used and the chamber operated at a pressure of 750 psia. Engine-delivered specific impulse performance was constant at 0, 0.5 and 1.0% silicone additive levels. However, decreased engine performance efficiency was found when the silicone concn was increased from 1 to 2% by wt. In conclusion, Loftus et al reported that the best additives found for each fuel are: For UDMH – dimethylpolysiloxane (see below); for MMH – hexamethyldisilazane; and for the 50/50 blend – methylcyanoethylpolysiloxane

Berman et al (Ref 28) also investigated heat-transfer reduction in liq proplnt combinations of N_2O_4 –monomethylhydrazine and Nitrogen Tetroxide–(A-50) caused by the addn of various siloxanes in N_2O_4 . It was found that the addn of 0.6 to 1.8% siloxane resulted in heat-transfer reductions > 30% by forming SiO_2 coatings on the rocket engine walls during combustion. An addn to the data of Loftus et al was reported

by Heubusch (Ref 29), also as a result of the Air Force sponsored Bell Aerospace Co's liq proplnt improvement program. He found that silicone oil ("SF-96-5") was a suitable additive to unsymmetrical dimethyl hydrazine. The patent of Gordon et al (Ref 33a) suggests that addn of a siloxane to a solid proplnt will provide combustion stability and, therefore, avoid extreme pressure peaks during combustion. Thus, Gordon reports that a proplnt containing a siloxane stabilizer burned with a nearly constant pressure of 600 psig for approx 6 secs, whereas the same proplnt stabilized with cellulose acetate exhibited two pressure extremes and continuously decreased pressure after less than 4 secs of combustion. The ballistic and mechanical properties of various proplnts contg Amm Perchlorate, Al and a silicone binder are reported by Doriath (Ref 36). Examples of typical parameters include combustion rates of 35mm/sec for a specific impulse of 233 secs at 100 bars as measured in a strand burner. It was found that the mechanical properties of the proplnts are relatively stable between –60 and 60°; no degradation was observed at RT or at 60° for three years. However, the mechanical properties of the proplnts did not allow for the use of a molded case-bonded technique

The work with silicones in *pyrots* is of interest at this point. Douda in Ref 6 outlines the feasibility study performed to explore the use of a silicone resin ("Sylgard 182" – Dow Corning Corp) as a binder for the Mk 24 AP Flare candle. He found that, although the illumination achieved by the use of this particular silicone resin was 20% less than a standard candle, silicone resin compns could be easily mixed, handled and pressed, and are insensitive to the hazards associated with other plastic resin systems. Douda was so impressed with the possibilities of silicone resins that he recommended further exptl work. His recommendation resulted in a study to find the optimum diameter and binder system for a 25 million candle cast flare (Refs 8 & 9). He reported that the candidate silicone resin ("Sylgard 182" mixt) binder when used in candles of over five inches in diameter was superior in terms of flame intensity and increased burning rate over binders comprised of epoxy-polyglycol, polyester, polysulfide, epoxy polyester or Na perchlorate–methyl methacrylate. In this study

the 25 million candle goal is achieved by igniting all surfaces of a four pointed star shaped cavity which is formed thru the center of a cast 16.0" diameter candle from end-to-end. Typical data from this candle is tabulated in Table 3

Obviously Douda felt that a silicone resin binder was the right approach to a high illumination flare compn, for he next patented a formulation (Ref 11) similar to the successful one developed during his earlier investigation. In his patent he claims an illuminating flare that is tough, durable and relatively insensitive to drop, friction and electrostatic energy is provided by a mixt of granular Mg (54–62), Na nitrate (28–38), and a silicone resin such as "Sylgard 182" (3–15%); ". . . the resin being a complex mixture of organopolysiloxanes having Me, Ph and vinyl radicals attached to Si atoms and offering a safety advantage in that it has no vapor pressure or odor and develops no exotherm during polymerization . . .". The patent further suggests that the ingredients be mixed into a homogeneous mass, poured into a 16" diameter mold and pressed at 8450 psi to form a candle which, in the example shown in the patent, is 16" long, weighs 56.75kg, with a burning time of 81 secs, a burning rate of 700.6g/sec and exhibits a candlepower of 8.3×10^6 cdl

The next patent of interest in the current pyrot literature is that of Duguet (Ref 30) which suggests that silicone oil can be used to coat powdered ingredients such as Pb azide as part of a coating compn which may also include either polyesters, polyurethanes or NC. The purpose of the coating is to decrease friction and hot-wire sensitivity. The coating procedure includes soln of the polymer in a ketone (2–20%), addn of 10–60 wt % of the azide, and finally the addn of 20–60 wt % of the silicone oil. The coated grains are then dried in the open for 2–3 hrs.

Van Vooren's patent (Ref 31) claims that the use of 10–23p of a liq silicone resin as a binder, 30p of 250–300 micron Mg as the fuel, and 60p of 6–20 micron Na nitrate as the oxidizer will produce pyrots having a luminous efficiency greater than 16000 candle-sec/g which are safe, easily prepd and handled

There are several US military specifications on silicones that are worthy of mention: a) "Silicone Compound", **MIL-S-8660B** (Ref 6a) which specifies requirements for a moisture and corrosion sealing compd for shells and, b) "Silicone, Encapsulant, Room Temperature Curing for Space Applications", **MIL-S-83384** (USAF) (Ref 15)

Table 3
16.0-Inch Diameter Star Cavity Cast Flare

<u>Binder</u>	<u>Silicone^{-a}</u>	<u>Epoxy-Polyglycol^{-b}</u>
Composition:		
Magnesium, % (granulation)	56.8 (sieve size 17–1.09mm)	56.6 (sieve size 15–1.29mm)
Sodium Nitrate, % (particle size)	28.8 (150 microns)	29.0 (150 microns)
Aluminum Chaff, %	—	1.0
Binder, %	14.4	14.0
Luminous Intensity (10^6 cd)	25.0	13.6
Burning Time, secs	36.0	93
Efficiency (10^3 cd-sec/g)	11.1	15.5
Burning Rate (inches/sec)	0.13	0.05
Burning Rate (10^3 g/sec)	2.2	0.87
Composition Weight (10^3 g)	81.6	81.7

Footnotes to Table 3:

a - "Sylgard 182" mix (Dow Corning Corp)

b - ". . . 62% QX 3812 and 38% DER 732 . . ." possibly, a mixt of an epoxy with polyethylene glycol (Ref 39, p 700)

According to Sax (Ref 10) the silicones have low toxicity with no irritating effects

Presented next is a series of polysiloxane compds which are frequently specified as either fuels or binders in ordn applications:

Polydimethyl siloxane [Polydimethylcyclosiloxane, Polymethylsiloxane, PDS or (D)_n]. The properties of siloxanes of the general formula $[\text{Si}(\text{CH}_3)_2\text{O}]_n$ are presented in Table 4 (Ref 2, p 360)

Solvents which swell these siloxanes are usually hydrocarbons such as toluene. Soln is obtd in ethyl acetate and CCl_4 (Ref 4). Prepn of the cyclodimethyl siloxanes is accomplished by the complete hydrolysis of dimethyldiethoxysilane. The silane is heated with a mixt, in equal volumes, of 95% ethanol and concd HCl (1:1) at bp for 4–8 hrs. The reaction product is washed, dried under reduced pressure at 120° , and the volatile dimethyl siloxanes are then distd off up to 250° (at 4mm). The mixt which has been distd off is again treated with 20% HCl at bp,

washed, dried and rectified. In this process the individual cyclic dimethylsiloxanes tabulated above are obtd (Refs 1, 2 & 13). Prepn of *linear polymers* from the cyclic siloxanes consists of treatment of the cyclic compds with very small portions of 97% sulfuric acid or NaOH with vigorous stirring. Large linear polymer molecules ready for conversion to silicone rubbers by copolymerization (as, for example, with diphenyldichlorosilane) are obtd (Refs 2a & 2b, p 135)

Examples of the usage of polymethylsiloxane in energetic materials from the current literature include (in *expls*) the work of Bowers et al (Ref 19) who investigated the mechanisms involved in impact sensitivity and desensitization of RDX by using an automatic impact–expln detection system to explore the effectiveness of mixing or coating RDX with a series of compds. He found that PDS was third in the order of effectiveness behind $n\text{-C}_{16}\text{H}_{34}$ (hexadecane) and w. Bowers theorizes that liquids

Table 4
Properties of Siloxanes of General Formula $[\text{Si}(\text{CH}_3)_2\text{O}]_n$

No of Si Atoms	Molecular Weight	OB to CO_2 , %	MP, $^\circ\text{C}$	BP, $^\circ\text{C}$	Sp Grav, $d_{4^{\circ}}^{25}$	RI, n_D^{25}	Flash Point, $^\circ\text{C}$	Viscosity at 25° Centistokes
4	296.56	– 91.72	17.5	175	0.955 at 20°	1.3968 at 20°	–	–
5	370.71	–129.48	–44	204.5	0.9531	1.3948	77	3.87
6	444.85	–129.48	–3	125 at 20mm	0.9613	1.3996	93	6.62
7	518.99	–129.48	–32	148 at 20 mm	0.9664	1.4118	109	9.47
8	593.13	–129.48	30	97 at 0.5mm	–	1.4039	132	13.23
9	667.27	–129.48	–	130 at 1mm	–	–	–	–
10	741.41	–129.48	–	150 at 1mm	–	–	–	–
11	815.55	–129.48	–	169 at 1mm	–	–	–	–
12	889.69	–129.48	–	189 at 1mm	–	–	–	–

such as PDS desensitize by filling in some of the voids in solid expls, thus reducing the number of gas pockets which are potential sources of the hot spots causing expl initiation. The patent of Thomas (Ref 22) suggests that a polymethylsiloxane be used to provide a waterproof coating for PETN. Thus, PETN (650p), w (228p) and acet (1950p) are mixed with 1 p of PDS for 5 mins. After drying it was found that a fuse made from the mixt is ignitable after 72 hrs w immersion (as compared to non-PDS addn mixts whose fuses were useless after 5 hrs immersion)

In *proplnts*, Burton's patent (Ref 3) claims that the addn of PDS and a glycol-adipic acid polyester to a mixt comprising 75p of Amm Perchlorate, 25p of polyisobutylene and 1 p of Cu chromite will give a thixotropic heterogeneous monopropnt with a linear burning rate of 0.70 inch/sec at 70°F and 1000 lbs/inch² chamber pressure. A pressure exponent of 0.50 is also reported by Burton. In another patent, that assigned to Nitrochemie G.m.b.H. (Ref 7), it is suggested that PDS be used as a binder-fuel in a perchlorate based proplnt compn. It is claimed that these proplnts have better stability, store better and have a higher deflagration temp than conventional proplnts. Fabrication is as follows: An anhyd mixt of 2400p of Amm Perchlorate and 2280p of K perchlorate is adjusted to the desired grain size and mixed in a kneader or mixer for 20 mins with 120p of Al dust. The mixt is then passed thru a 0.3mm screen and introduced in four portions at 15-min intervals into 1200p of polymethylsiloxane (viscosity 750 centistokes at 20°) previously heated to 95° in a kneader. When thoroughly mixed, the kneader is evacuated to 100mm and kneading is continued for 2 hrs at 95°. After addn of 30p of a rapid hardener, kneading in vacuo is continued for a further 5 mins. The mass is then poured into an insulated vessel heated to 95° and finally into molds, while still warm. In a proplnt compn invention whose patent is assigned to Josef Schaberger and Co, G.m.b.H. (Ref 27), it is suggested that PDS be used as a binder-fuel in composite propergol charges along with liq Tetranitromethane or Methyl Nitrate which have been adsorbed onto large surface area solids, such as activated carbon. Either Amm Perchlorate, NC, AN or K perchlorate are used as oxidizer

In the patent of Evans and Gordon (Ref 37) PDS is claimed to act as a combustion inhibitor when applied to the surface of a solid proplnt. This is accomplished by the use of three layers: a base layer formed from a soln contg tetrahydrofuran (100p), powdered Al (10p), polyvinyl formal (5p) and methylmethoxyurone (0.25p); an intermediate layer containing PDS in a solvent; and an inhibiting layer comprised of liq PDS, applied with or without fillers, which undergoes partial cross-linking to provide a self-supporting condition. The treated proplnt is then cured at 70% RH for 5 days at 15–30°. The patent of Murphy and Larrick (Ref 4) claims that the spark and friction sensitivity of *pyrot* igniters containing particulate Zr as the fuel and Fe oxides as oxidants can be decreased in a controlled manner by addn of various thicknesses of PDS coatings. Fabrication consists of mixing 0.5 to 5.0 wt % of PDS dissolved in a solvent carrier such as ethyl acetate or carbon tetrachloride with either the Zr particles before the particles are mixed with the other components of the compn, or the PDS soln may be applied to an already mixed formulation which contains Zr particles

Written by H. L. HERMAN

Refs: 1) Gmelin, System Nr 15, Teil C (1958), 242 ff 2) K.A. Andrianov, "Organic Silicon Compounds", Vol I, State Scientific Tech Pub-Chem Lit, Moscow (1955), 26–28, 129 & 375 2a) Ibid, Vol II, Ibid, 701 & 747 ff 2b) H.L. Fisher, "Chemistry of Natural and Synthetic Rubbers", Reinhold, NY (1957), 134–37 3) J.M. Burton, "Thixotropic Heterogeneous Monopropellants", USP 3113894 (1963) & CA 60, 6695 (1964) 4) M.F. Murphy & B.F. Larrick, "Controlled-Sensitivity Igniter Compositions", USP 3110638 (1963) & CA 60, 3944 (1965) 5) H.H. Ender, "Organosiloxane-Coated Propellants", USP 3190775 (1965) & CA 63, 8114 (1965) 6) B.E. Douda, "Silicone Resin Systems in Illuminating Flares", NAVAMODEP RDTR101, Crane (1966) 6a) Anon, "Silicone Compound", MIL-S-8660B (1967) 7) Anon, "Castable or Extrudable Propellants", BritP 1061390 (1967) & CA 66, 106747 (1967) 8) B.E. Douda, "25 Million Candle Cast Flare, Diameter and Binder Study", Vol I, NAVAMDEP RDTR105, Crane (1968)

- 9) Ibid, Vol II, NAVAMDEP RDTR 105, Crane (1968) 10) Sax (1968), 1090 11) B.E. Douda, "Magnesium-Sodium Nitrate-Vinyl-Terminated Polysiloxane Flare Composition", USP 3411964 (1968) & CA 70, 30547 (1969) 12) J.M. Hammond et al, "Siloxane Polyurethane Composite Propellant Binders", AIAAJ 1970, 8 (1), 163-64 & CA 72, 80981 (1970) 13) H.K. Lichtenwalner & M.N. Sprung, "Silicones", in "Encyclopedia of Polymer Science and Technology", H.F. Mark, Ed, Vol 12 (1970), 464-569 14) no ref 15) Anon, "Silicone, Encapsulant, Room Temperature Curing for Space Applications", MIL-S-83384 (USAF) (1972) 16) C.F. Key, "Impact Sensitivity of Materials in Contact with Liquid and Gaseous Oxygen at High Pressures", Space Shuttle Mater, Nat, SocAerospMaterProcess Engrg Tech Conf 1971, 557-63 & CA 76, 86815 (1972) 17) L.E.G. Hallstrom & N.G. Lindner, "Preparing Fuel Bodies for Hybrid Rockets with Nitric Acid as the Oxidant by Bringing Together a Fluid Amine Fuel and an Elastomer", SwedP 312293 (1969) & CA 78, 74346 (1973) 18) Anon, "Solid Propellant Having an Improved Burning Rate", BritP 1300381 (1972) & CA 78, 113573 (1973) 19) R.C. Bowers et al, "Mechanisms Involved in Impact Sensitivity and Desensitization of RDX . . .", IndEngChemProd-ResDev 1973, 12 (1), 2-13 & CA 79, 21175 (1973) 20) W.A. Statesir, "Explosive Reactivity of Organics and Chlorine", ChemEng-Progr 1973, 69 (4), 52-54 & CA 79, 33270 (1973) 21) B.A. Stott & D.A. Sbrocca, "Plastic-Bonded Explosives", USP 3728170 (1973) & CA 79, 33288 (1973) 22) H. Thomas, "Modified Pentaerythritoltetranitrate", GerP 2248627 (1973) & CA 79, 44042 (1973) 23) Anon, "Solid Propellant with an Inhibitor Coating", GerP 2257742 (1973) & CA 79, 94194 (1973) 24) J. Green, "High-Burning Rate Solid Propellant Having a Silicon-Carboranyl Copolymer Fuel Binder", USP 3738878 (1973) & CA 79, 147869 (1973) 25) H.J. Loftus et al, "Propellant Improvement Program. III. Additives for Heat Flux Reduction", USNat-TechInformServ AD 1972-756913 & CA 79, 116697 (1973) 26) D.L. Ornellas, "The Heat and Products of Detonation in a Calorimeter of CNO, HNO, CHNF, CHNO, CHNOF, and CHNOSi Explosives", Comb&Flame 23, 37-46 (1974) & CA 81, 172463 (1974) 27) Anon, "Composite Propergol Charges Using Liquid Combustion Supporters Stable at Normal Temperatures", FrP 1605107 (1973) & CA 81, 108109 (1974) 28) K. Berman et al, "Additives for Heat-Transfer Reduction in the Propellant Combinations Nitrogen Tetroxide-MMH (Monomethyl Hydrazine) and Nitrogen Tetroxide-A-50", JSpacecr,Rockets 1973, 10 (8), 493-95 & CA 82, 127132 (1974) 29) H.P. Heubusch, "Propellant Improvement Program. 4. UDMH . . . Silicone Studies", NTIS Rep AD 772816/5GA (1973) & CA 81, 108059 (1974) 30) J.R. Duguet & M.L. Sanmartin, "Pyrotechnic Substances", GerP 2412523 (1974) & CA 83, 118065 (1975) 31) G. Van Vooren, "Pyrotechnic Flares", FrP 2248252 (1975) & CA 84, 7206 (1976) 32) S. Fujiwara et al, JapP 74134811 (1974) & CA 84, 7213 (1976) 33) G. Martel & A. LeDu, "Explosive Composition", FrP 2268770 (1975) & CA 84, 166922 (1976) 33a) S. Gordon et al, "Rocket Motors", CanP 987113 (1976) & CA 85, 80523 (1976) 34) C.B. Hackett et al, "Surface-Inhibited Propellant Charge", BritP 1441240 (1976) & CA 85, 194933 (1976) 35) Merck (1976), 1099 (No 8237) 36) G. Doriath, "Sililanes, a New Propellant for Tactical Engines", AGARD Conf Proc 1976, 15 & 194 & CA 86, 108801 (1976) 37) G.I. Evans & S. Gordon, "Combustion-Hindering Material", GerP 2615633 (1976) & CA 86, 57649 (1976) 38) J.P.A.M. Kehren & R. Ousset, "Pressure-Formed, Thermostable Combined Explosives", GerP 2634195 (1977) & CA 86, 192086 (1977) 39) CondChemDict (1977), 774 40) J.M. Holovka, "Effects of HE-Binder Interactions on the Viscoelastic Properties of PETN/ and RDX/Sylgard-182 Formulations", CompatPlastOther-MaterExplosPropInts, Pyrot Symp 1976, III-C & CA 87, 87228 (1977) 41) W. Falterman & D.A. Sbrocca, "Plastic-Bonded Explosive Composition", USP 4047990 (1977) & CA 87, 203852 (1977)
- An *addnl* limited distribution Ref: J.H. Godsey & W.P. Freese, "Development of High Temperature Resistant Propellants", Summary Rep 1, ASD-TDR-62-1085, USAF, Wright-Patterson AFB (1963)

Silk, Nitrated. Vignon prepd a yel product by immersing ordinary silk in nitric acid (d 1.133 g/cc) at 45° for one min, followed by w washing. Although the dry product was not expl, it burned more rapidly than ordinary silk

Refs: 1) L. Vignon, *BullFr* **6**, 898 (1891)
2) *Ibid*, *JCS* **62**, II, 1111 (1891)

Siloidina. Ital for Nitrostarch. See in Vol **8**, N157-L to N162-R

Silver Acetylides. See under "Silver Acetylide, Disilver Acetylide or Silver Carbide" in Vol **1**, A79-R to A82-L

Addnl Refs: 1) V.D. Hogan & S. Gordon, "Silver Acetylides", *FRL-TR-3* (1960) [The history of research on the three compds that can be prepd from Ag nitrate and acetylene — Ag_2C_2 , $\text{Ag}_2\text{C}_2 \cdot \text{AgNO}_3$, and $\text{Ag}_2\text{C}_2 \cdot 6\text{AgNO}_3$ — is traced. The 3 compds were subjected to DTA anal both at ambient press and at reduced press simulating high altitudes of up to 150000 ft. The expln temps of the feebly expl compds Ag_2C_2 and $\text{Ag}_2\text{C}_2 \cdot 6\text{AgNO}_3$ (138° and 300°, respectively) were found to be substantially unaffected by reduced press. However, $\text{Ag}_2\text{C}_2 \cdot \text{AgNO}_3$ expld violently at 245° under ambient press, and at 195° at one torr]

2) S. Silverman, "Survey of the Literature on Light Initiation of Silver Acetylide-Silver Nitrate Explosive", *SciTechAerospace Rept* **4**, No 21, 4267 (1966) & *CA* **66**, 117499 (1968) [The impulse obtained from $\text{Ag}_2\text{C}_2 \cdot \text{AgNO}_3$ is about a factor of 44 less than that of LA, and 90 less than sheet expl. Applications such as expl forming of metals, dynamic material testing, military applications, and use as a primary expl are discussed]

3) Anon, "Light Detonates Slurry in Forming Technique", *C&EN* **43**, No 49 (1965), 46 [A method of low-level expl forming involves spraying a slurry of Ag acetylide-Ag nitrate in acet on a work piece, drying the coating, and deton it by a high-intensity light pulse]

4) W.E. Baker et al, "Development of Capabilities of a Light-Initiated, Sprayed Explosive", *Tech Rept IR Proj No 02-9008-01*, SRI (1969) [Applications include expl forming and welding, shock loading of brittle materials, and use of the

primary Ag acetylide-Ag nitrate as a simultaneous initiator for a more powerful secondary expl]

Silver Amide. See Vol **1**, A169-R to A170-L

Silver Azide. See under "Silver Azide" in Vol **1**, A597-R to A601-R

Addnl Refs: 1) Bretherick (1975), 155–56
2) H.D. Fair & R.F. Walker, Eds, "Energetic Materials-1, Physics and Chemistry of the Inorganic Azides", Plenum, NY (1977) 3) *Ibid*, "Energetic Materials-2, Technology of the Inorganic Azides", Plenum, NY (1977)

Silver Cyanamide. See under "Cyanamide and Derivatives" in Vol **3**, C581-L, plus the following addnl material:

Chretien and Woringer (Ref 1) described the prepn of Ag cyanamide from Ca cyanamide by the action of Ag nitrate, and also described its expl properties. Montagu-Pollock (Ref 3) described a method for growing large crystals of the salt from its aq soln in the presence of AN, ammonia and a surface active agent. Bowden and Montagu-Pollock (Ref 2) and Montagu-Pollock (Ref 3) studied the slow decompn of the crystals by electron microscopy when they were heated at temps from 150° to 360°. They concluded that a) nucleation by metallic decompn products was observed only in the special cases involving the initiation of holes of crystallographic shape; b) in general, decompn was found occurring everywhere on the crystal surface; c) the Ag produced by the decompn was very mobile on the crystal surface; and d) boundaries appeared separating areas of greater and lesser decompn

Refs: 1) A. Chretien & B. Woringer, *CR* **232**, 1115 (1951) 2) F.P. Bowden & H.M. Montagu-Pollock, *Nature* **191**, 556 (1961) 3) H.M. Montagu-Pollock, *ProcRoySoc(London)*, **A269**, 219 (1962)

Silver Imide. See Vol **7**, I34-R

Silver Nitride. See Vol 8, N102-L

Silver Nitrocyamide. See under "Cyanamide and Derivatives" in Vol 3, C581-L, plus the following addnl material:

Harris (Ref 2) reports that only the following nitrocyamide salts possess greater sensitiveness and may be considered to be of practical use:

K, Sn, Pb, Ba and Ag nitrocyamides

Comparing with the expts of Grant & Tiffany (Ref 1), Harris states that Ag and Ba nitrocyamides show an initiating capacity the same as that of an 80/20 mixt of MF/K chlorate, but weaker than an 80/20 LA/LSt mixt. In spite of their fairly promising initiating properties, nitrocyamide salts are of no practical use because of their high hygroscopicity

Refs: 1) R.L. Grant & J.E. Tiffany, IEC 37, 661 (1945) 2) S.R. Harris, JACS 80, 2302 (1958)

Silver Fulminate. See under "Silver Fulminate" in Vol 6, F223-R to F225-L & F227-L & R
Addnl Ref: Urbański 3, 157-58 (1967)

Silver Oxalate. See under "Silver Oxalate" in Vol 8, O30-R to O31-L
Addnl Ref: Urbański 3, 224

Silver Perchlorate. See under "Silver Perchlorate" in Vol 8, P167-L

Tetra Silverdinitridooxosulfate (VI).



AgN; mw 523.64; dark red crystals. Insol in acet, ethanol, eth, carbontetrachloride, chl_f, w, etc. Prepn is by addn of 100ml of concd aq ammonia to 4.8g of sulfuric diamide and 17g of Ag nitrate under red light. After concn of the resultant mixt to 10ml by means of a rotary evaporator, N, N'-diargentosulfuric diamide is pptd. This salt is filtered off and washed. The disilver salt is then converted to the trisilver salt by addn of an excess of 5% ammonia. The desired tetrasilver salt is subsequent-

ly prepd in almost 100% yield by digesting the trisilver salt with aq Ag nitrate soln in a beaker protected from light on a heated w bath. The tetrasilver salt decomps explosively in the dry state on mechanical shock (by rubbing or impact). It is stored under inert solvent

Refs: 1) Gmelin, not found 2) E. Nachbaur & A. Popitsh, "Dinitridodioxosulfate (VI), $\text{SN}_2\text{O}_2^{4-}$: A New Derivative of the Sulfate Ion", AngChemInternatEdn 12 (4), 339 (1973) & CA 79, 38072 (1973)

Silvered Vessel Test. See Vol 1, XXIV

Silylaminoboron Compounds. See under "Silylamines" in this Vol under "Silanes and Derivatives"

Silyl Azides. See under "Silyl Azides" in this Vol under "Silanes and Derivatives"

Simplonits. See under "Swiss Commercial Explosives of Nonpermissible Type" in Vol 3, C444-L

Simpson Explosives. Suitable for mining or quarrying operations. Consist of an alkaline nitrate and Al, or Al alloy, which may be coated with a waterproofing material such as paraffin. A typical formulation contains AN 90, Al 65 and Mn dioxide 3.5%

Ref: H.T. Simpson, BritP 435588 (1935) & CA 30, 1564 (1936)

Simulation. Simulation is the act of producing the effects of an event without duplicating the event. In the case of military weapons, simulation may be brought about for two main purposes, for training and for psychological purposes. Normally, simulators do not make use of the full battlefield effects of a weapon nor is their cost generally as great as that of the item for which the effect is being produced

Most often simulators mimic battlefield sounds, flashes, and lights produced by service ammo. In training use, they condition troops

for battle without the exposure to the hazard of handling live ammo

The primary types of simulators are described briefly below:

The *air burst simulator* (M27A1B1) is used to simulate the airburst of an artillery projectile for high-burst ranging practice

The *boobytrap simulator* (flash, M117) is used during maneuvers and in troop training where there is need for a small pyrot device which can be installed as a *safe* boobytrap. It functions with a loud report and flash when its victim unwittingly fires the simulator. This device is intended to provide training in the installation and use of boobytraps, as well as to instill caution in troops exposed to traps set by an enemy. Illuminating (M118) and whistling (M119) versions of this item are also available

The *ground burst simulator* (M115A2) is used on land only to simulate battle noises and effects (shells in flight and ground explns) during troop maneuvers. It produces a high-pitched whistle which lasts 2 to 4 seconds. In expld, it produces a flash and loud report

The *artillery flash simulator* (M110) produces a flash, a puff of white smoke, and a loud report. Its flash is similar to that of 90mm guns and 155mm howitzers. This simulator is used to train artillery observers and may actually be employed in forward combat areas as a decoy

The *hand grenade simulator* (M116A1) provides battle noises and effects during troop maneuvers. It is thrown in the same manner as a live grenade and creates a loud report and flash 5 to 10 seconds after ignition

The *explosive simulator* (M80) is used in boobytraps, land mine detection and deactivation training programs. It is used to simulate hand grenades, booby traps, land mines, and rifle or artillery fire

The *atomic explosion simulator* (M142) is a non-radioactive pyrot device, completely housed in a standard 55 gal drum, which is designed to simulate a ground-detonated nuclear expln. It produces a bright flash, a loud report, and a mushroom-shaped cloud

Each type of simulator requires considerable study of the effects that are to be reproduced. For light producers, the influence is mainly that of vision along with association of what is seen with the circumstances surrounding the vision.

If, for example, troops know they have no artillery in the area but suddenly see and hear air bursts in the vicinity, the troops will believe that enemy activity includes artillery after all. The tide of battle could thus be changed merely by simulation of artillery air bursts, perhaps by a very limited force

Refs: 1) Anon, "Military Pyrotechnics", **TM9-1370-200** (1966), 5-1 to 5-21 2) Anon, "Ammunition, General", **TM9-1300-200** (1969), 9-19 to 9-20 3) Anon, *EngrgDesHndbk*, "Design of Ammunition for Pyrotechnic Effects", **AMCP 706-188** (1974), 3-21 4) Anon, *draftTechManual*, "Army Ammunition Data Sheets for Military Pyrotechnics (National Supply Class 1370)", **TM 43-0001-37** (1975)

"Synoxyd" Priming Compositions (Synoxyd Zündung or Sinoxydsatz in Ger). Non-corrosive priming compns developed in Ger prior to WWII

Priming mixts contg MF, K chlorate, and Sb sulfide tend to destroy the inside of firearm barrels, since on decompn the MF evolves free Hg which causes erosion of the barrel at the high temps created inside the bore. Decompn of the K chlorate gives KCl which remains in the bore and strongly corrodes the steel. Sulfur dioxide formed by the combustion of Sb sulfide also helps to destroy the barrel. For a long time therefore, the use of compns *not* contg MF and K chlorate were advocated, but a satisfactory formulation for non-corrosive mixts was found (*Synoxyd*) only when PbSt was introduced as their chief component (Ref 1). Since styphnate is difficult to ignite by impact it was sensitized by an admixture of tetracene (Ref 4). At the same time K chlorate was replaced by Ba nitrate (Ref 5)

Ger compns for rifle and pistol caps are tabulated below (Refs 2 & 3)

Table 1
German "Synoxyd" Formulations

	Compn No 30/40 for Rifle and Pistol Caps	Compn for Rifle Caps Manufd at Stadeln
Lead Styphnate, %	40	30-35
Tetracene, %	3	2-3
Barium nitrate, %	42	40-45
Lead dioxide, %	5	5-8
Calcium silicide, %	10	6-12
Antimony sulfide, %	-	6-9

The Czech mixt, *Oxyd*, for pistol cartridges has a similar compn: PbSt 45, tetracene 5, Ba nitrate 33, Sb sulfide 20 and Al-Mg alloy 5%. The Ger mixt No 30 for the friction fuses of hand grenades has the following compn: PbSt 25, Ba nitrate 25, Pb dioxide 24, Si 15 and ground glass 3% (Ref 5)

See under "Primers" in Vol 8, P375-L for typical US formulations

Refs: 1) E. von Herz, SS 28, 37-42 (1933) & CA 27, 2580 (1933) (Die Erosionsfreie Zündung) 2) Anon, "Manufacture of Initiating Explosives, CIOS Rept XXVII-38 (no date) 3) Anon, "Report on the Visit to D.A.G. Small Arms Factory, Stadeln", CIOS Rept XXXIII-48 (no date) 4) Anon, "Handbook of Foreign Explosives", FSTC 381-5042 (1965) 5) Urbański 3 (1967), 234-35

Sintered Metal Bullets. Woodworth patented a method for forming bullets by sintering a metal powder contg Cu or a Cu alloy, the particles of which are bound together by a powdered metal of lower mp such as Sb. After compression in a mold, the bullet is heated above the mp of Sb but below that of Cu or Cu alloy

Ref: A.L. Woodworth, BritP 531389 (1941) & CA 35, 8300 (1941)

Sipalin AOM. Ger trade name for the methylcyclohexyl ester of adipic acid. It was incorporated in solvents for NC (such as 75/25 butyl acetate/ethyl alc), the soln being used to coat electric detonator fuseheads by a dipping procedure. The Sipalin resulted in a NC varnish coating which was less permeable to moisture and less readily cracked

Ref: R. Ashcroft, BIOS Final Rept No 833, London (1946), p A3/34

Siperite. See under "Siperite o MNDT (Explosivo)" in Vol 7, I177-R (Italian Explosives and Related Items)

Sismite. Ital expl used for seismic prospecting. See under "Tutamite" in Vol 7, I181-L (Italian Explosives and Related Items)

Sixolite. Same as Tetramethylolcyclohexanol Pentanitate (qv)

Sixonite. Same as Tetramethylolcyclohexanone Tetranitrate (qv)

Size, Classification; Size, Particle. See under "Particle Size Measurements of Solid Propellants, Explosives, and Pyrotechnics" in Vol 8, P18-R to P59-L

Sjöberg Explosives. See under "Curds (called Caillebotte in French)" in Vol 3, C557-L

Skid Test. See initial information in Vol 4, D332-R to D324-L

Updated Information. The following material (Table 1) is taken from B.M. Dobratz, "Properties of Chemical Explosives and Explosive Simulants", UCRL-51319, Rev 1, Lawrence Livermore Laboratory, Livermore, Calif (1974)

Results from a sliding impact sensitivity test (skid test) with large hemispherical billets of HE have proved valuable for evaluating the plant-handling safety of HEs (Refs 1 & 2). The test was developed at AWRE in Engl

In the Lawrence Livermore Laboratory (LLL)-Pantex version of this test, the expl billet, supported on a pendulum device, is allowed to swing down from a preset height and strike at an angle on a sand-coated steel target plate. Impact angles employed are 14 deg (0.24 rad) and 45 deg (0.79 rad) (defined as the angle between the line of billet travel and the horizontal target surface; the heights vary). The spherical surface of the billet serves to concentrate the force of the impact in a small area; the pendulum arrangement gives the impact both a sliding or skidding component as well as a vertical one. The results of the test (Table 1) are expressed in terms of the type of chemical event produced by the impact as a function of impact angle and vertical drop. Chemical events are defined as follows:

- 0 No reaction; charge retains integrity
- 1 Burn or scorch marks on HE or target; charge retains integrity
- 2 Puff of smoke, but no flame or light visible

Table 1
Standard LLL-Pantex Skid Test
with Hemispheres of Explosive 11 Inches (0.28m) in Diameter and Weighing 23 Lbs (10.4kg) ^a

Explosive	Impact angle		Vertical drop		Chemical event
	(deg)	(rad)	(ft)	(m)	
Comp B-3	14	(0.24)	3.5	(1.07)	0
	14	(0.24)	5.0	(1.52)	1,0,4
	14	(0.24)	7.1	(2.16)	2
	45	(0.79)	28.0	(8.53)	0
Cyclotol 75/25	14	(0.24)	0.62	(0.19)	0
	14	(0.24)	0.88	(0.27)	4
	14	(0.24)	1.75	(0.53)	3
	45	(0.79)	7.1	(2.16)	0
	45	(0.79)	14.0	(4.27)	0
	45	(0.79)	28.0	(8.53)	0
LX-04-01	14	(0.24)	1.75	(0.53)	0
	14	(0.24)	2.5	(0.76)	2
	14	(0.24)	14.1	(4.30)	2,1
	45	(0.79)	3.5	(1.07)	0,0
	45	(0.79)	5.0	(1.52)	3,0
	45	(0.79)	7.1	(2.16)	1,0
	45	(0.79)	10.0	(3.05)	2
	45	(0.79)	14.1	(4.30)	3
LX-07-01	14	(0.24)	0.88	(0.27)	0,0,0,0
	14	(0.24)	1.25	(0.38)	0,0,0
	14	(0.24)	1.75	(0.53)	0,0,0
	14	(0.24)	2.5	(0.76)	6,4,3
	45	(0.79)	2.5	(0.76)	0,0
	45	(0.79)	3.5	(1.07)	0,0,0,0,0
	45	(0.79)	5.0	(1.52)	0,0,0
	45	(0.79)	7.1	(2.16)	5,0,0,0,0,0,0
LX-09-0	14	(0.24)	0.88	(0.27)	0,0,0,0
	14	(0.24)	1.25	(0.38)	6,0,0
	45	(0.79)	3.5	(1.07)	0,0,0
	45	(0.79)	5.0	(1.52)	6,0,0,0
	45	(0.79)	7.1	(2.16)	0
LX-10-0	14	(0.24)	0.88	(0.27)	0,0,0,0,0 0,0,0,0
	45	(0.79)	2.5	(0.76)	0,0,0
	45	(0.79)	3.5	(1.07)	6,6,0,0,0 0,0,0,0,0 0,0,0,0,0
Octol 75/25	14	(0.24)	2.5	(0.76)	0,0
	14	(0.24)	3.5	(1.07)	6,6
PBX-9010	14	(0.24)	0.88	(0.27)	0
	14	(0.24)	1.25	(0.38)	6,0,0,0
	14	(0.24)	1.5	(0.46)	0
	14	(0.24)	1.75	(0.53)	0,0

(continued)

Table 1 (continuation)

Explosive	Impact angle		Vertical drop		Chemical event
	(deg)	(rad)	(ft)	(m)	
PBX-9011	14	(0.24)	7.1	(2.16)	0
	14	(0.24)	10.0	(3.05)	0
	14	(0.24)	20.0	(6.10)	2
	45	(0.79)	14.1	(4.30)	0
	45	(0.79)	20.0	(6.10)	0
PBX-9205	14	(0.24)	0.88	(0.27)	0
	14	(0.24)	1.25	(0.38)	2
	14	(0.24)	1.75	(0.53)	3
	45	(0.79)	1.25	(0.38)	0
	45	(0.79)	1.75	(0.53)	0
	45	(0.79)	2.5	(0.76)	4
PBX-9404	14	(0.24)	0.88	(0.27)	0,0,0,0
	14	(0.24)	1.25	(0.38)	6,6,6,0
	14	(0.24)	1.75	(0.53)	6,6
	45	(0.79)	1.75	(0.53)	0,0,0,0,0,0
	45	(0.79)	2.5	(0.76)	0,0,0
	45	(0.79)	3.5	(1.07)	6,0,0,0
					0,0,0,0
	45	(0.79)	5.0	(1.52)	6,6,6,6,0
				0,0,0,0	
				6,6	
PBX-9501	14	(0.24)	1.25	(0.38)	0,0,0
	14	(0.24)	5.0	(1.52)	0
	14	(0.24)	10.0	(3.05)	3
	45	(0.79)	5.0	(1.52)	0,0,0
	45	(0.79)	10.0	(3.05)	0,0,0

^a One inch = 2.540×10^{-2} m; 1 lb = 4.535924×10^{-1} kg; 1 ft = 3.048×10^{-1} m; 1 deg = 1.745329×10^{-2} rad

- in high-speed photography. Charge may retain integrity or may be broken into large pieces
- 3 Mild low-order reaction with flame or light; charge broken up and scattered
 - 4 Medium low-order reaction with flame or light; major part of HE consumed
 - 5 Violent deflagration; virtually all HE consumed
 - 6 Detonation

The sliding-impact test results are significant indications of plant-handling safety because the drop heights and impact angles used in the test are quite within the limits one might find for the accidental drop of an expl billet. The test is used not only to evaluate the *relative sensitivity* of different expls, using the sand-coated target as a ref surface (Table 2), but also to evaluate typical plant floor coverings, using PBX-9010 as a ref expl (Table 3)

Table 2
Nonstandard Skid Tests of Interest
Target: Standard Sand-Coated Steel [1/4-inch (6.375-mm)] Bonded to Concrete^a

Explosive		Weight		Impact angle		Vertical drop		Chemical event
		(lb)	(kg)	(deg)	(rad)	(ft)	(m)	
Comp B		50	(22.7)	14	(0.24)	5.0	(1.52)	4
LX-04-0	-57°F (224K)	23	(10.4)	45	(0.79)	3.5	(1.07)	2
	60°F (290K)	23	(10.4)	14	(0.24)	1.25	(0.38)	0
		23	(10.4)	14	(0.24)	1.75	(0.53)	2
		23	(10.4)	45	(0.79)	3.5	(1.07)	0
		23	(10.4)	45	(0.79)	5.0	(1.52)	3
	235° (385K)	23	(10.4)	14	(0.24)	5.0	(1.52)	0
		23	(10.4)	45	(0.79)	14.1	(4.30)	0
		50	(22.7)	45	(0.79)	7.1	(2.16)	0
LX-04-1		298	(135.2)	45	(0.79)	0.88	(0.27)	0
		298	(135.2)	45	(0.79)	1.25	(0.38)	0
		298	(135.2)	45	(0.79)	1.75	(0.53)	5
LX-09-0	Aged 11 months; 70°C (343K)	28	(12.7)	14	(0.24)	0.88	(0.27)	0
		28	(12.7)	45	(0.79)	2.5	(0.76)	0
		28	(12.7)	45	(0.79)	3.5	(1.07)	6,0
	Control for aged sample	28	(12.7)	14	(0.24)	0.88	(0.27)	6
		28	(12.7)	45	(0.79)	2.5	(0.76)	0
		28	(12.7)	45	(0.79)	3.5	(1.07)	0,0
LX-10-0	Made with Fluorel	23	(10.4)	14	(0.24)	0.88	(0.27)	0,0,0
		23	(10.4)	45	(0.79)	3.5	(1.07)	0,0,0
	With 48 lbs (21.8kg) of steel plate on HE equator	69	(31.3)	14	(0.24)	0.44	(0.13)	0
		70	(31.8)	14	(0.24)	0.66	(0.20)	6
LX-14-0		291	(132)	45	(0.79)	0.88	(0.27)	0
		292	(132.4)	45	(0.79)	1.25	(0.38)	0
		291	(132)	45	(0.79)	1.50	(0.46)	0
		290	(131.6)	45	(0.79)	1.75	(0.53)	0
		290	(131.6)	45	(0.79)	2.5	(0.76)	0
		290	(131.6)	45	(0.79)	5.0	(1.52)	6
PBX-9404		296	(134.3)	14	(0.24)	0.25	(0.08)	0
		292	(132.4)	14	(0.24)	0.33	(0.10)	6
		296	(134.3)	14	(0.24)	0.48	(0.15)	6
		296	(134.3)	45	(0.79)	0.33	(0.10)	0
		298	(135.2)	45	(0.79)	0.44	(0.13)	0
		293	(132.9)	45	(0.79)	0.63	(0.19)	0
		291	(132.0)	45	(0.79)	0.63	(0.19)	0
		297	(134.7)	45	(0.79)	1.23	(0.38)	0
		295	(133.8)	45	(0.79)	1.83	(0.56)	0
		296	(134.3)	45	(0.79)	2.5	(0.76)	0

(continued)

Table 2 (continuation)

Explosive		Weight		Impact angle		Vertical drop		Chemical event
		(lb)	(kg)	(deg)	(rad)	(ft)	(m)	
PBX-9501	-34°C (239K)	23	(10.4)	14	(0.24)	0.62	(0.19)	6
	16°C (289K)	23	(10.4)	14	(0.24)	0.88	(0.27)	0,0,0,0,0
	16°C (289K)	23	(10.4)	14	(0.24)	1.25	(0.38)	6,6,0
	-34°C (239K)	23	(10.4)	45	(0.79)	0.88	(0.27)	0 ^b
	-34°C (239K)	23	(10.4)	45	(0.79)	1.25	(0.38)	0 ^b
	-34°C (239K)	23	(10.4)	45	(0.79)	1.75	(0.53)	0 ^b
	-34°C (239K)	23	(10.4)	45	(0.79)	2.5	(0.76)	0 ^b
	-34°C (239K)	23	(10.4)	45	(0.79)	3.5	(1.07)	0 ^b
	-34°C (239K)	23	(10.4)	45	(0.79)	5.0	(1.52)	6
	16°C (289K)	23	(10.4)	45	(0.79)	2.5	(0.76)	0,0,0
	16°C (289K)	23	(10.4)	45	(0.79)	3.5	(1.07)	6,6,0,0,0
	16°C (289K)	23	(10.4)	45	(0.79)			0,0,0,0,0
	16°C (289K)	23	(10.4)	45	(0.79)			0,0,0,0,0
	16°C (289K)	23	(10.4)	45	(0.79)			0,0,0,0,0
	71°C (344K)	23	(10.4)	45	(0.79)	2.5	(0.76)	0
	71°C (344K)	23	(10.4)	45	(0.79)	3.5	(1.07)	0
	71°C (344K)	23	(10.4)	45	(0.79)	5.0	(1.52)	0
	71°C (344K)	23	(10.4)	45	(0.79)	7.1	(2.16)	0

^a One inch = 2.540×10^{-2} m; 1 lb = 4.535924×10^{-1} kg; 1 ft = 3.048×10^{-1} m; 1 deg = 1.745329×10^{-2} rad

^b Acrid or burnt odor noticed after test

Table 3
Evaluation of Plant Floorings by LLL-Pantex Test with 50-lb (22.7-kg) Hemispheres of PBX-9010 and, Except Where Otherwise Noted, 45 deg (0.79 rad) Impact Angle^a

Floor Material	Thickness		Vertical drop		Chemical event
	(inches)	(mm)	(ft)	(m)	
Corrugated rubber floor covering					
Against grain			10	(3.05)	0, 0
With grain			10	(3.05)	0
			20	(6.10)	0
Linoleum	1/8	(3.18)	7.1	(2.16)	0
			10.0	(3.05)	0
			14.1	(4.30)	0
			20.0	(6.10)	0
Poly-Con ^b			2.5	(0.76)	0
			3.5	(1.07)	0
			5.0	(1.52)	0
			7.1	(2.16)	6
14 deg (0.24 rad) impact angle			1.25	(0.38)	0
			1.75	(0.53)	0
			2.5	(0.76)	0
			3.5	(1.07)	0
			5.0	(1.52)	6
Polyurethane (Adiprene L-100)	5/64	(1.98)	7.1	(2.16)	0
			14.1	(4.30)	0
			24.0	(7.32)	0
Sanded steel			1.75	(0.53)	0
			2.5	(0.76)	6, 6
Torginal (Torga-Deck)	1/16	(1.59)	14.0	(4.27)	0
			20.0	(6.10)	6
	3/16	(4.76)	20.0	(6.10)	0
	to	to	28.0	(8.53)	1
	1/4	(6.35)			
Urapol floor covering	3/32	(2.38)	10	(3.05)	0
			14.1	(4.30)	0
			20	(6.10)	0
	1/8	(3.18)	10	(3.05)	0
			14.1	(4.30)	0
			20	(6.10)	0
14 deg (0.24 rad) impact angle			20.0	(6.10)	0
Vinyl			5.0	(1.52)	0, 0
			7.1	(2.16)	6, 6

^a One inch = 2.540×10^{-2} m; 1 lb = 4.535924×10^{-1} kg; 1 ft = 3.048×10^{-1} m; 1 deg = 1.745329×10^{-2} rad

^b A poured polyurethane floor covering

Refs: 1) L.G. Green, A.M. Weston, and J.H. van Velkinburg, "Mechanical Behavior of Plastic-Bonded Explosives Vertically Dropped on a Smooth, Rigid, Steel Target Surface", LLL Rept UCRL-51022 (1971) 2) Ibid, "Mechanical and Functional Behavior of Skid Test Hemispherical Billets", LLL Rept UCRL-51085 (1971)

Slant Range. The line-of-sight range between two points not at the same elevation. Used as a distinguishing term. This term is used in reference to range between an airborne gun or radar set and a ground target or other target not at

the same elevation, between an antiaircraft gun and the future position of a target, between a bomber and a target, etc. In operations, slant range includes the range between objects vertical to one another

Ref: J. Quick, "Dictionary of Weapons and Military Terms", McGraw-Hill, NY (1973), 403

Slider. A fuze or exploder component that interrupts the expl train when the device is in the unarmed condition, and that moves during arming in such a way as to render the expl train operative

Ref: Anon, OrdnTechTerm (1962), 280-R

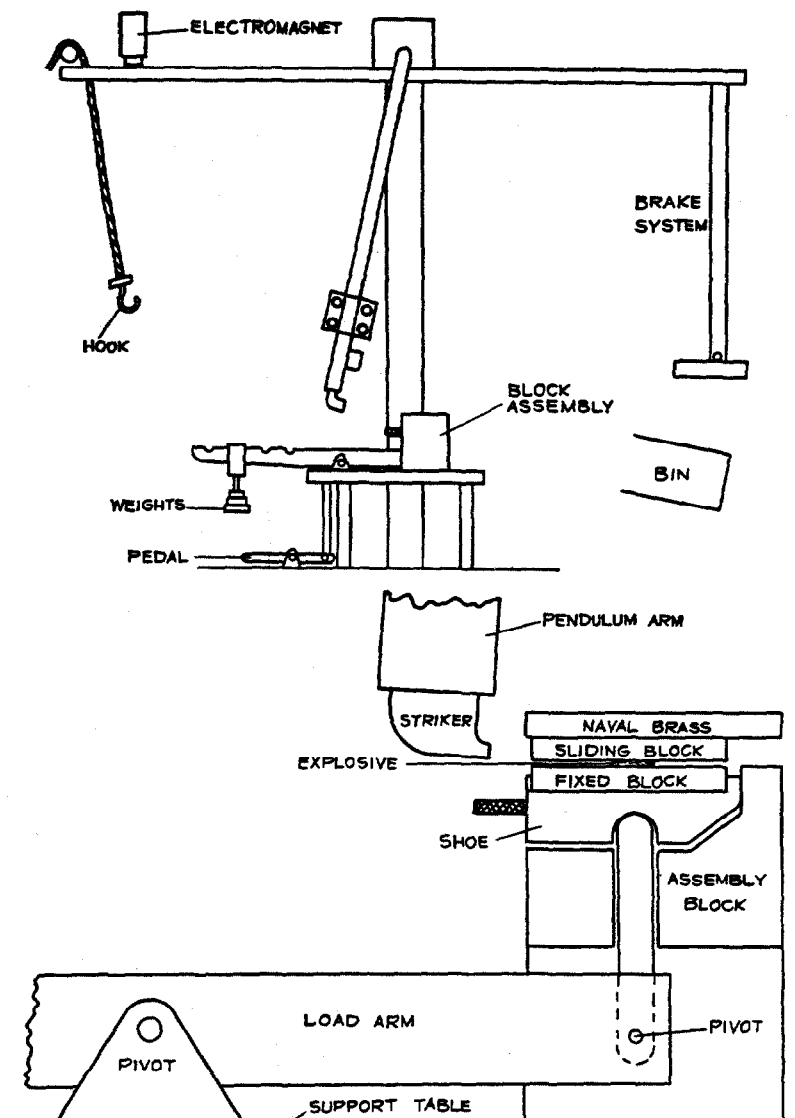

Fig 1 Sliding-block Friction Apparatus (top) and Block Assembly and Striker (bottom)

Sliding-Block Friction Test. In the sliding-block friction test (Fig 1), a sample is subject to frictional forces when clamped between two prepared steel surfaces (Ref 2). The upper sliding block is constrained to move horizontally over the lower fixed block by guides. A pedal-operated mechanism permits the load to be released so that the sliding block assembly can be inserted

A 5' pendulum with striker is released from a raised position by means of an electromagnet. After being struck, the upper block is ejected thru the guides into a rubber bin which is in line with the swing of the pendulum. The pendulum continues upward and is arrested by means of a spring-loaded braking system. The velocity of strike for the max height is 22'/sec. The applied load can be varied in the range from ounces to 150 lbs

The surfaces of the blocks are ground, and the expl sample is dispensed onto the bottom plate in the center by means of a filling plate, 0.015" thick with a hole 0.095" diam

Ten trials at the same load are performed, then the load is either increased or decreased depending upon the result. Reactions are recorded as audible reports, visible flashes, flash marks on the blocks, smoke, or fumes. The sensitivity is defined in terms of the load required to give one ignition in ten trials

A modification of the sliding-block technique was developed by Bowden and Yoffe (Ref 1), the app subjecting the expl to rapid shear while under a known load

See also under "Friction Sensitivity Tests" in Vol 6, F204-L to F206-L, and in Vol 1, XIII and XIV

Refs: 1) F.P. Bowden & A.D. Yoffe, "Initiation and Growth of Explosion in Liquids and Solids", Cambridge Univ Press, Cambridge, Engl (1952)
2) G.R. Walker, Ed, "Manual of Sensitiveness Tests", CARDE, Valcartier, Quebec, Canada (1966)

Sliding Torpedo Test. See under "Torpedo Friction Test" in Vol 6, F205-L to F206-L

Slow Match or Slow Fuse (Mèche lente in Fr). According to Daniel (Ref 1), it is prep'd by im-

pregnating a sheet of paper in a hot conc'd salt-peter soln, drying it, rolling it in the form of a compact tube, and glueing the edge. The burning time of such a cylinder is up to 3 hrs

Barnett (Ref 3, p 158) describes it as a loosely woven hemp cord slightly impregnated with K nitrate, which smolders slowly. Another version (Ref 3, p 175) can be prep'd by soaking blotting paper in Pb nitrate soln (2.5 lbs/gal), and, after drying, pasting the sheets together, usually to give 6 thicknesses

According to Marshall (Ref 2) slow match is made by boiling loose hemp cords in a dilute salt-peter soln; it smoulders away at the rate of a ft in several hrs

Refs: 1) Daniel (1902), 433 2) Marshall 2 (1917), 540 3) Barnett (1919), 158 & 175

SLUFAE. Acronym for **S**urface **L**aunched **U**nit **F**uel **A**ir **E**xplosive **M**ine **N**eutralization **S**ystem

Land mines and expl booby traps accounted for up to 70% of US tank and vehicle losses and more than 33% of personnel casualties during recent wars. The clearing of mines in the Suez area following the Middle East War was a major problem

Current methods of breaching minefields and clearing expl booby traps — including hand emplacement of demolition charges, use of tanks for pushing or propelling linear expl charges, and mechanical clearing devices — are inadequate and outmoded for the modern battlefield. Requiring considerable prep'n, manual effort or logistical support, these techniques are slow and inhibit mobility. The delivery vehicle must be adjacent to the mine or minefield during breaching or clearing operations, and exposure to enemy fire lessens chances of mission accomplishment

The **SLUFAE** Mine Neutralization System is under development to meet this requirement. Tests indicate it will provide ground combat forces with a vehicle-mounted system rapidly deployable to breach minefields and neutralize expl booby traps, in daylight or darkness, or any environment

Representing a recent development in advanced weapons technology, **FAE** weapons employ foliage discriminating fuzes that actuate on target contact and rupture thin-walled warheads to disperse highly volatile liq chemicals in aerosol

clouds (see under "FAE and FAX" in Vol 6, F3-L to F4-R). The clouds are detonated automatically by delay detonators projected into them by the central burster charges that formed them

The state-of-the-art of FAE technology has been advanced, but major technological restrictions remain for FAE weapons. They must be parachute-retarded and are 2-event systems. Repeatable impact velocities are required to allow time for FAE cloud formation and to insure proper detonator positioning. Blast effects, however, are sufficient to detonate or neutralize antitank and antipersonnel mines and expl booby traps

Applications of FAE have proved effective in extensive tests and evaluations against live mines of the US, NATO, and Soviet Bloc countries. These tests have shown FAE to be effective against not only single- and double-impulse pressure-fuzed antitank mines and pull-fuzed antipersonnel mines, but also against the complex fuzed magnetic-influence and long-impulse high-blast-resistant land mines. FAE blast effects were found equally effective in detonating underwater land mines tactically emplaced in the waters in front of defended river lines or beaches and shorelines

The SLUFAE system consists of a 30-tube armored launcher mounted on the M548 full-tracked cargo carrier, a rocket propelled FAE round, a firing control intervalometer, and launcher operating control

Ref: J.A. Dennis, Army R&D News (May-June 1976), 14

Slurry Explosives

I Introduction

Slurry Explosives, also known as *slurries*, *water gels* (*aquatols* or *aquanits* in Russ), are mixts of dough-like consistency containing oxidizers and fuels, both with or without expl sensitizers, dispersed in a fluid medium which is usually a water soln of the oxidizing salts. Often these mixts contain thickening agents as well as ingredients that act as aerating agents or gas formers. Slurry expls that do not contain expl sensitizers (eg *TNT*) and cannot be initiated with

a No 8 blasting cap are classified as *blasting agents*. From now on we will refer to cap-sensitive and/or expl-containing slurries as **SE**, and blasting-agent type slurries as **SBA**

The main oxidizing ingredient of all commercial **SE** and **SBA** is ammonium nitrate (**AN**). Lesser amounts of other oxidizers such as Na nitrate and Na perchlorate are also used in some formulations. A great variety of fuels is used, eg hydrocarbon oil, carbon, sugar, etc. Part or all of the fuel can also act as the sensitizer if it consists of TNT, Comp B, Nitrostarch, smokeless powder, Monomethylamminenitrate (**MMAN**), etc. Metal fuels such as Al or Si give the slurry an increased energy output and may provide some sensitization. Hydrophilic thickening agents such as *guar gum* increase slurry viscosity thereby decreasing water penetration when slurries are used under wet conditions. They also prevent settling of the solid ingredients. There is a general tendency of **SE** and **SBA** to become less sensitive to blasting cap or booster initiation as they age. This is overcome by including a small amount of gas-producing ingredient or aerating agent in the slurry compn

SE and **SBA** are primarily used in commercial blasting. Consequently this article will emphasize compns, expl props and commercial applications of slurries. Fluid-solid mixts such as $\text{RDX-H}_2\text{O}$ or $\text{HMX-H}_2\text{O}$, which are nominally expl slurries, will not be considered. A brief historical survey will be presented in Section II; followed by prepn methods and uses in Section III; compns and Trade Names in Section IV; Explosive Characteristics in Section V; a brief overview of patents and literature in Section VI; and Refs in Section VII

II History

According to Cook (Ref 3), the first field trial of Al-sensitized slurries was made in Canada, and the first commercial slurry, *Hydromex*, was marketed in 1958 by Canadian Industries Ltd (CIL). Shortly thereafter slurries were successfully tried on Mesabi taconite ores. By the end of 1960, CIL, IRECO, Dupont and Hercules were all marketing slurry expls. Since then the commercial use of **SE** and **SBA** has experienced a continuous and rapid growth. This is shown in Table 1 with data taken from the Mineral Industrial Surveys of the US Bureau of Mines.

Table 1
Water Gels and Slurries Consumption by Use
(Thousands of Pounds)

Year	Coal mining	Metal mining	Quarrying and non-metal mining	Construction work	All other purposes	Total
1967	4,136	123,250	28,036	11,012	584	167,018
1968	7,107	151,164	34,163	12,665	1,419	206,518
1969	9,583	162,359	35,517	12,598	1,478	221,535
1970	8,910	161,682	31,113	12,779	372	214,856
1971	9,132	172,616	33,004	15,390	550	230,692
1972	9,212	156,618	41,305	17,783	1,325	226,243
1973	11,622	173,530	54,154	22,863	1,376	263,545
1974	22,204	160,198	75,837	32,610	2,399	293,248
1975	24,118	181,809	73,872	30,413	920	311,132
1976	30,871	205,429	74,176	28,743	1,475	339,372
1977	42,406	154,704	75,062	43,653	1,940	317,194

Note that the metal mining industry is the largest user of slurries. The apparent decline in slurry sales in 1977 is accounted for by a large decline in metal mining during that year, and particularly by the great reduction in Cu mining in 1977

The earliest slurry expls were capable of detonating only in large diameter columns. Developments soon led to SE that would detonate over the same diameter range as NG Dynamites. The current popularity of Slurries in commercial blasting is best exemplified by the fact that Dupont, the largest commercial expl manuf in the US, has switched entirely to Slurries and no longer sells NG Dynamite. Most of the other expl producers still manuf Dynamites as well as Slurries. Trade names of Slurries made in the US are given in Table 2, which also indicates whether the Slurry is classified as an *explosive* (SE) or a *blasting agent* (SBA)

So far in this brief historical overview we have studiously avoided the subject of inventorship of slurry expls. This is still a matter of intense and acrimonious controversy. Slurry patent rights have been the subject of several protracted litigations. Consequently the writer will approach this subject with caution and trepidation

It appears that the first *commercially used* Slurries were developed by Cook and his associates. There is no doubt that Cook was the

prime driving force in the rapid acceptance of Slurries for commercial blasting, as well as the developer of many Slurry systems. The patent situation, as already noted, is complex. The original Cook patent is US 2930685 (1960) and its reissue, Re 25695 (1964). Cook's patent, US 3121036 and Re 25695 appear to be in conflict, at least from the legal point of view, with Hradel (assigned to Dow), US 2992912 (1961) and US 3094443 (1963). The basic Dupont patent for the use of Monomethylaminenitrate (MMAN) sensitized Slurries appears to be Dumlinson & Lyerly, US 3431155 (1969). The basic Hercules patents for the use of smokeless powder or Ethanalamine Nitrate sensitizers are Clemence & Lawrence, US 3235425 (1966) and Fee & Lawrence, US 3401067 (1968), respectively. The Atlas *Emulsion Slurry* "Aqual" system is covered by Bluhm, US 3447978 (1969). Gulf has patented the inclusion of Hexamethylenetetramine (presumably as a sensitizer) in Partridge, US 3496040 (1970)

The very voluminous patent literature on Slurries is summarized in Section VII

III Manufacture and Uses

A Manufacture

At present Slurries are made at expl plants and also mixed right on the blasting site. Plant-

mixed Slurries are generally prepd in a ribbon-type mixer and packed into plastic sleeves. Usually these Slurries are sent to a distributor's magazine which then services users in its vicinity. On-site mixing will be described in detail in the following section. In general, the app for on-site mixing consists of a paddle-type mixer, and it is pumped directly into boreholes by a positive displacement pump

B Uses

As already mentioned, SE and SBA are primarily used in commercial mining. Because of their excellent w resistance, SE and SBA are particularly applicable to blasting under wet conditions. A dense Slurry bulk-loaded into a borehole can provide high expl loading per borehole. This can be important in obtaining good rock breakage in "tough" materials such as

Table 2
Trade Names of US Commercial Slurries

Manufacturer	Trade Name	Type
Apache Powder Co	Carbagel	SBA
	Dynagel	SE
Atlas Powder Co	Aquagel	SE
	Aqua-Flo	SBA
Austin Powder Co	Slurmite	SBA
E.I. duPont de Nemours	Tovex 100, 200, 500	SE
	600, 700 & 800 series	
	Tovex 300 Series	Permissible SE
	Tovex S	Seismographic
		Exploration SE
	Tovex P	SE for priming ANFO
	Tovex Extra	SE (a)
	Pourvex Extra	SE (a)
Tovan Extra	Pump truck SE (a)	
Energy Science & Consultants	Thermoprimer W	SBA
	MS-80	SBA
	Dellek	SBA
Gulf Explosives, Gulf Oil Chemicals	Slurran 800 series	SBA
	Slurran 900 series	SE
	Detagel	SE
Hercules Inc	Gel-Power O	SBA
	Gel-Power A	SE
	Gel-Strip	SBA
Ireco Chemicals	Iregel	Pumped SBA
	Iretol	Packaged SBA
	Iremex-F	Packaged SE
	Iremite	SE (aluminized)
	Ireprime	SE primer
IMC-Trojan Division	Trojel EZ POR	SBA
	Trojel	SBA

(a) Non-cap sensitive expl

taconite, a low grade iron ore. The combination of "tough" rock and wet conditions is often encountered in metal mining. Thus it is not surprising that Slurries have found their best market in metal mines (see Table 1)

In quarries and construction blasting, Slurries are primarily used as "bottom loads" in the wet portions near the bottom of the borehole, and the remainder of the expl load above the Slurry is usually *ANFO*, a mixt of AN and fuel oil. According to Table 1, Slurry consumption in quarrying and construction work has remained fairly constant over the last five years. Over the same period, the use of Slurries in coal mines has increased rapidly. In part this is due to an increase in coal mining activity, but may also be due to the acceptance of small-diameter SE in underground coal mines. These Slurries are particularly suited to underground mining, since their high w content should reduce their incendivity with fire damp and/or coal dust. Furthermore, they are non-headache producing (no NG) and their detonation products contain fewer toxic fumes than those of Dynamites (See Section V-F)

However, Slurries are not the "perfect" expls for commercial blasting that some manufs claim them to be. Occasionally they exhibit unexpected variability in their performance. Their useful shelf-life is limited and their detonability is affected by ambient temp and pressure. A qualitative comparison of the characteristics of Slurries and Dynamites is shown in Table 3. This comparison suggests that Dynamites can still compete successfully with Slurries and are not about to become extinct in the near future

In military applications, Slurries have not gained much ground. They were tried (apparently unsuccessfully) in foxhole diggers, and somewhat more successfully in large bombs for clearing helicopter landing sites (Ref 11). In the latter application IRECO's DBA-22M Slurry (which contains no self-expl ingredients or even Al) was pumped continuously into a huge bomb of 45000 lbs gross weight!

The increased acceptance of SBA in commercial mining is to a large degree due to a novel method of loading SBA into boreholes. In the "pumper-truck", Slurry mixing and pumping operations have been successfully combined as

Table 3
Qualitative Comparison between SE & Dynamites

Property	Comparison
Energy Content	Comparable
Rate of Detonation	Dynamites have a wider range
Gap-Sensitivity*	Dynamites have a wider range
Impact and Friction Sensitivity	SE are appreciably less sensitive
Detonation Fumes	SE fumes are less toxic
Ambient Temperature Effect	Detonability of Dynamites affected considerably less by ambient temperature than that of SE
Ambient Pressure Effect	Detonability of Dynamites affected considerably less by ambient pressures than that of SE
Water Resistance	SE have much better water resistance than most Dynamites
Headache Cause	SE do not produce headaches; Dynamites do
Shelf-life	Dynamites have appreciably longer shelf-life
Consistency of Performance	Occasionally performance of SE becomes erratic; less so with Dynamite
Packing Density Control	Better with Dynamites than with SE

* Propagation across an air gap. This is desirable in the event there is charge separation in a borehole, but undesirable if it can occur via a crack connecting adjacent boreholes

described by Cook (Ref 9, pp 21–22):

“SBA readily lends itself to efficient on-site bulk mixing because of its high fluidity (before gelling) and some remarkable time-controlled, thickening and gelling agents. One may not only achieve excellent ultimate slurry texture but may also control the gelation rate to permit high fluidity during flow of slurry through the pumping system. Two main techniques are in use for bulk slurry: (1) plant mixing of bulk slurry subsequently extruded into the borehole by pressure-loading equipment and (2) on-site mixing and loading called “SMS”, or “site-mixed slurry” method

Method (1) is relatively inflexible and more costly. Plant-mixed and extruded slurries have to be thin and often somewhat more sensitive than desired. Otherwise they are not easily pumped thru the hose and into the borehole. Furthermore, they require relatively high water content. The more sensitive, incompletely thickened slurry has to be transported over public highways, a practice previously forbidden as far as bulk explosives were concerned. Additional thickeners are added during actual loading into the borehole in order to permit easy loading but still give the required viscosity to prevent segregation and loss into the formation once the slurry is in place in the borehole

Method (2), the SMS method, is far the more versatile for bulk handling of slurry. This method optimizes water and explosive ingredient handling and eliminates costly storage. Most important, it has made available more economical slurry products not previously available in packaged form. The quick gelling- and cross-linking action-improved gelling agents, especially adaptable to this particular method, have given even better water resistance and slurry quality than in early packaged slurry products. Slurries can therefore be mixed and pumped simultaneously at relatively low pumping pressure, yet they thicken sufficiently while still in the loading hose and in the borehole itself to give the desired properties at all stages

The SMS method for slurry in open-pit mining has set a standard for safety unprecedented in the history of commercial explosives. As mentioned above, whenever an NCN slurry (including the most attractive aluminum types) is used in the SMS method, only nonexplosive

ingredients need to be stored, transported, and used. Premixed, nonexplosive oxidizers and fuels are stored and handled separately and form an explosive only upon being metered into the mixing chamber and pumped into the borehole. As a matter of fact, by using sub-critical dimensions in the pump and hose sections, the mixture will not propagate a detonation while in the system. Furthermore, the SMS method has made available high quality, economical service in remote areas far removed from conventional plants”

IV Slurry Compositions

The basic ingredients of all commercial Slurries are AN dissolved in w and additional undissolved AN. AN is the major oxidizing ingredient and the w provides the liq phase, which is a necessary constituent of any Slurry. A few formulations contain relatively small amounts of other oxidizers — usually Na nitrate (SN). Polar solvents are sometimes added to the liq phase. The fuel may be any combustible material including oxygen-deficient expls, although the latter are generally called *sensitizers*. Common fuels are hydrocarbons, cellulose and/or Al. Common sensitizers are Monomethylaminenitrate (MMAN), TNT, Ethanolaminenitrate and paint-grade Al. As military surplus stocks became available, Comp B & smokeless powder were also used as sensitizers. Modern Slurries are “thickened” and frequently “cross-linked”. The usual “thickener” is guar gum, a natural polysaccharide product. Hydrogen-bonding agents, eg, borate ions, are the usual “cross-linkers”. Gas bubble content is important in maintaining Slurry sensitivity (see Section V-G). Some aeration is naturally introduced during Slurry preparation by air entrapment. Gas formers such as NaNO_2 or H_2O_2 are frequently added to maintain gas bubble content, particularly if the Slurries are to be shot under high hydrostatic pressures

Exact Slurry compns are usually not available because they are considered to be trade secrets. One of the earliest, if not the first, commercial Slurry, sold by CIL under the name of *Hydromex*, consisted of 38/25/25/12 AN/SN/TNT/ H_2O (Ref 1). Apparently the early IRECO Slurries — the DBA Series — were not very different from Hydromex. For example, DBA-1

Table 4
Classes of Well-Characterized Slurry Explosives and Slurry Blasting Agents

Designation ^a	Percent Sensitizer	Oxidizer ^b	Percent Water	
			Nominal	Range
SE-TNT	17-60 TNT	AN, SN, BN, SC, NaP, C	15	8-40
SE-CB	15-35 CB	AN, SN, C	15	12-16
SE-SP	20-60 SP	AN, SN, BN, SC, NaP, C	15	2-20 ^c
SE-HSSP	20-60 HSSP	AN, SN, C	15	2-20 ^c
SE-TNT/A1	5-25/0.5-40 TNT/A1	AN, SN, NaP, C	15	10-30
SE-SP/A1	10-25/1-40 SP/A1	AN, SN, C	15	12-30
SBA-A1	1.0-40 A1	AN, AN/SN, AN/NaP, NaP	11	6-30 ^c
	0-12 fuel			
SBA-fuel	4.0-15 fuel	AN, AN/SN, NaP, SC	11	3-16 ^c

a TNT, trinitrotoluene; CB, composition B; SP, smokeless powder; HSSP, high strength smokeless powder; fuel, various types – sulfur, gilsonite, other solid hydrocarbons, NH₄ – lignosulfonate, others

b AN, ammonium nitrate; SN, sodium nitrate; BN, barium nitrate; NaP, sodium perchlorate; SC, sodium chlorate; C, combinations (AN/SC incompatible)

c Low percent limit requires water extenders, such as formamide, ethylene glycol, sugar, molasses

Table 5
Slurry Ingredients

Oxidizers

Ammonium nitrate
Sodium nitrate
Nitric acid
Calcium nitrate
Chlorates
Perchlorates

Gas Formers

Peroxides
Acetone and creosote
Sodium and
potassium nitrites
Sodium bicarbonate

Cross-Linking Agents

Boron compounds
Potassium dichromate
Antimony compounds
Bismuth compounds
Periodates
Litharge

Aerating Agents

Fibrous pulps and meals
Vermiculite
Resin microballoons
Perlite
Glass microballoons
Cork

Gelling Agents

Guar gum
(polysaccharide)
Starch
Acrylamide Polymers

Liquid Medium

Water
Ethylene glycol
Formamide

(continued)

Table 5 (continuation)

Fuel-Sensitizers	
Explosive	Nonexplosive
TNT	Aluminum
PETN	Sugar
RDX	Urea
Pentolite	Ferrosilicon
Composition B	Ferrophosphorus
Guanidine nitrate	Wood pulp
Smokeless powder	Dinitrotoluene
Nitrostarch	Hexamine
Alkylamine nitrates	Ethylene glycol
Nitromannite	Fuel oil
	Paraffin
	Coal
	Carbon
	Sulfur
	Lignosulfonates
	Plant fibers and meals
	Glycerin
	Nitrocellulose
	Gilsonite

consists of 60/15/25 AN/SN/TNT with 10–20p water and 0.2–0.4p guar gum, while DBA-2 has 32/32/36 AN/SN/TNT and the same w and gum content as DBA-1 (Ref 2)

Some general compn ranges (such as would appear in patent applications) are given in the tabulation (Table 4) taken from Cook (Ref 9, p 19)

Indeed, the patent literature abounds in Slurry compns that are in effect variations upon the main theme set forth in Table 4

A somewhat different compn, much too costly for commercial use, but apparently under consideration for military applications, consists of: 48 (75 Nitromethane/25 Nitroethane)/30 RDX/10 Al/2 NC. It has a d of 1.45g/cc, is cap-sensitive and detonates at 6800m/sec (Ref 11)

An additional Slurry ingredients list (more specific than the tabulation in Table 4 but showing no compn ranges), taken from Ref 8, is shown in Table 5. This list classifies the various ingredients as oxidizers, fuels, etc

V Explosive Characteristics

A Detonation Velocity

The detonation velocities, D , of numerous Slurries are shown in Table 6, which also gives data on the effect of charge diameter on D . Note that the range of D is from about 3700 to

6300m/sec. Although this is a respectable range it is not as large as that available with NG Dynamites

Ito and coworkers (Ref 7) detd D as a function of distance from the primer. In a 34-mm diam steel pipe with a 10g Tetryl primer the following results were obtained:

Distance from Primer (cm)	65/35/20/0.5	65/7/25/3
	AN/TNT/H ₂ O/gum D (m/sec) at 1.37g/cc	AN/Al/H ₂ O/gum D (m/sec) at 1.22g/cc
2.5–5	6700	6200
5–7.5	5000	5000
7.5–10	5500	4000
10–12.5	5300	3700
12.5–15.0	5000	3700
15–17.5	4800	3900
17.5–20	4700	4000

Measurements in an actual borehole (Ref 8) are summarized in Fig 1. The Slurry consisted of 44.5/40/15/0.5 AN/TNT/H₂O/gum which was shot in a 75-mm borehole while primed with 150g of Pentolite

Unlike military expls or NG Dynamites, SE and SBA have maxima in their D vs ρ curves. This is shown in Fig 2. In this respect Slurries resemble ANFO. Possible causes for this effect will be examined in a later section

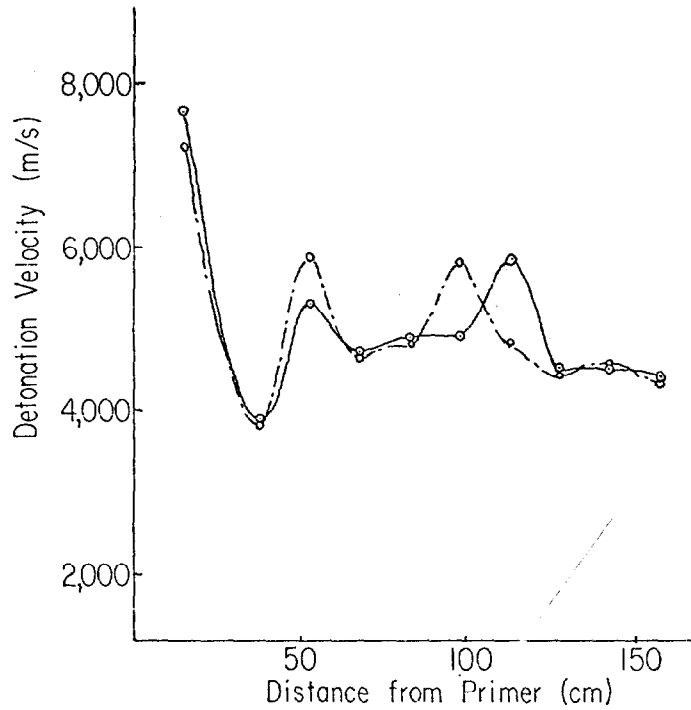

Fig 1 Detonation Velocity of a TNT Slurry as Function of Distance from the Primer (Ref 8)

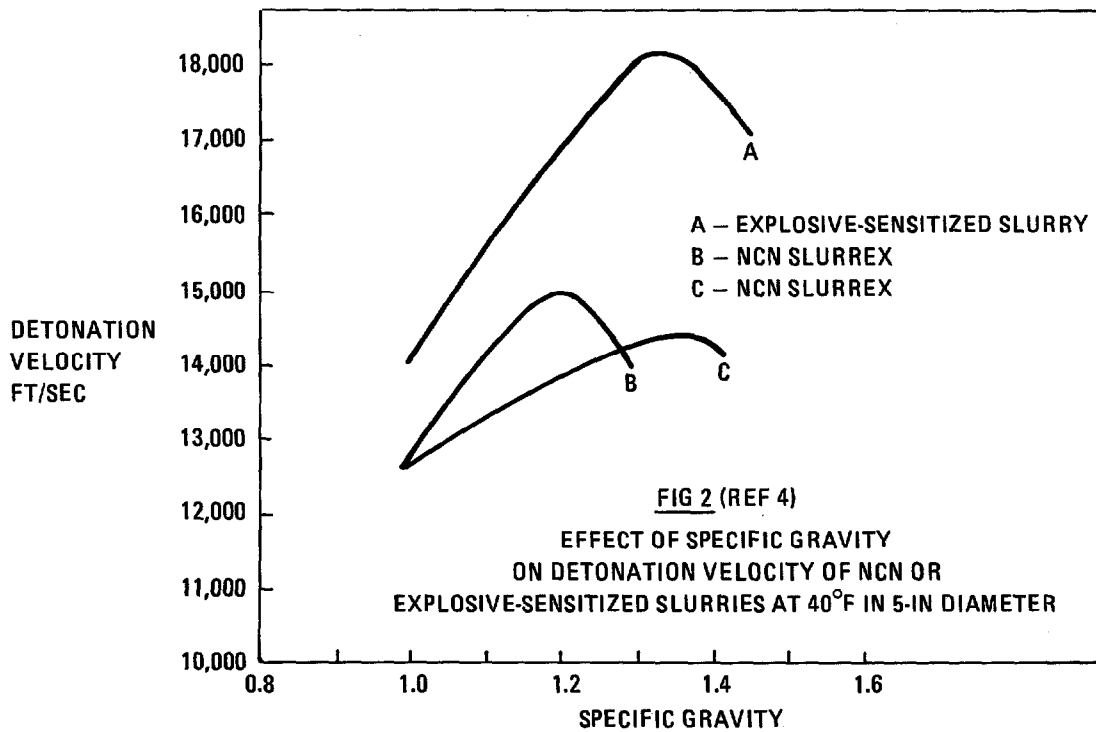

Table 6
Detonation Characteristics of Selected Commercial Slurry Explosives

Slurry (a)	Sensitizer (b)	Density (g/cc)	Deton Vel (m/sec)	Deton Pressure (kbar)	Deton Energy (Kcal/g)	Critical Diam (d) (cm)	Ref
Tovex 100	MMAN	1.10	3880 at 1" (c)	—	0.80	< 2.5	(e)
	MMAN	1.10	4500 at 1½" (c)	—	0.80	< 2.5	(e)
	MMAN	1.10	4910 at 2" (c)	—	0.80	< 2.5	(e)
Tovex 200	MMAN	1.10	3990 at 1" (c)	—	—	< 2.5	(e)
	MMAN	1.10	4880 at 1½" (c)	—	—	< 2.5	(e)
	MMAN	1.10	5000 at 2" (c)	—	—	< 2.5	(e)
Tovex 700	MMAN	1.20	4800 at 2" (c)	—	0.96	< 4.5	(e)
Tovex 800	MMAN	1.20	4800 at 2" (c)	—	1.07	< 4.5	(e)
Tovex S	MMAN	1.38	4800 at 2½" (c)	—	1.12	< 5.5	(e)
Gel Power A-1	—	1.10	3960 at 2" (c)	—	0.64	< 2.5	(e)
	—	1.10	5180 at 5" (c)	—	0.64	< 2.5	(e)
Gel Power A-2	—	1.10	3960 at 2" (c)	—	0.75	< 2.5	(e)
	—	1.10	5180 at 5" (c)	—	0.75	< 2.5	(e)
Gel Power A-3	—	1.10	3960 at 2" (c)	—	0.86	< 3.8	(e)
	—	1.10	5180 at 5" (c)	—	0.86	< 3.8	(e)
Gel Power A-4	—	1.10	3960 at 2" (c)	—	0.96	< 3.8	(e)
	—	1.10	5180 at 5" (c)	—	0.96	< 3.8	(e)
Gel Power O-1	—	1.20	4270 at 2" (c)	—	0.64	< 5	(e)
	—	1.20	5180 at 5" (c)	—	0.64	< 5	(e)
Gel Power O-4	—	1.20	4270 at 2" (c)	—	0.96	< 5	(e)
	—	1.20	5180 at 5" (c)	—	0.96	< 5	(e)
Trojel EZ	TNT	1.46	5030 at 5" (f)	—	—	< 7.6	(e)
Trojel	Nitrostarch	?	≥ 6100 at ?	120–125	—	< 5	(e)
DBA-1 (g)	TNT	1.52	4900 at 5"	85	1.04 (h)	10	(2)
	TNT	1.52	5100 at 5" (c)	103	1.04 (h)	10	(2)
DBA-2 (g)	TNT	1.68	5500 at 5"	97	1.03 (h)	3.8	(2)
	TNT	1.60	5270 at 5" (c)	111	1.03 (h)	3.8	(2)
Pourvex	MMAN	1.36	5900 at 2" (c)	—	—	5	(10)
	MMAN	1.36	6330 at 4" (c)	130	~1.0 (h)	5	(10)
Aquanal (i)	Al	1.43	3730 at 4" (c)	55	~0.7	>5<10	(10)
	Al	1.20	5500 (j)	90	—	< 7.6	(e)
DBA65T2	TNT(?), Al	1.52	5400 at 4" (c)	120	~1.2 (h)	—	(10)
DBA-22M	Al	1.52	5000 (?)	81	1.96	—	(8)
IREGEL 435	Al	1.2	3900 (?)	—	0.66	—	(8)
Slurran 615	Al	1.38	4300 (?)	—	0.66	—	(8)

(See Footnotes on Following Page)

Footnotes to Table 6:

- (a) See Table 2 for manufacturer and classification
- (b) Ethanolamine nitrate
- (c) Confined in steel pipe of the diam shown (in inches)
- (d) If not specifically known, the values are for the smallest diam cartridges sold
- (e) Manufacturers' trade literature
- (f) In borehole
- (g) Now replaced by IREGELS and IREMITES
- (h) Values given are relative to ANFO; recomputed with ANFO energy = 1.02kcal/g
- (i) This is an "Emulsion Slurry" of the SBA type, in which it is claimed that each particle of the mixture is coated by the wax/oil and water emulsion, thus providing outstanding water resistance
- (j) Claimed to be independent of charge diameter

B Explosive Strength of Slurries

A general description of expl strength or blasting ability is given under *Power of Explosives* in Vol 8, P364-L to P366-R. Many methods have been used to "measure" expl strength. For commercial expls the methods employed are: Ballistic Mortar, cratering, seismic energy and underwater bubble energy. The last two methods appear to be the ones mostly used for SE and SBA. Eilo (Ref 4) claims that the results of the underwater method correlate very well with actual blasting practices

In Table 6, expl strengths of various Slurries are denoted as *Detonation Energy*. The values obtained from Trade Literature are most likely based on underwater measurements. The values obtained by Cook (Refs 2, 3 & 9) are from seismic measurements, and the values obtained by Finger

et al (Ref 10) are based on measurements of metal cylinder expansion

The energy provided by both SE and SBA varies with Slurry d in much the same fashion as detonation velocity. This is shown in Fig 3, taken from Ref 4. Incidentally, what is termed a NCN Slurry in the Fig has been called SBA in this article

The energy developed by Slurries depends on external pressure. For dense Slurries, delivered energy decreases steadily as ambient pressure is increased. Low and intermediate d Slurries exhibit maxima in their energy vs ambient pressure plots. This is shown in Fig 4 (Ref 4)

Borehole temp also affects Slurry energy release. This effect is shown in Fig 5 (Ref 4). Note that high d Slurries will not perform well at low ambient temps

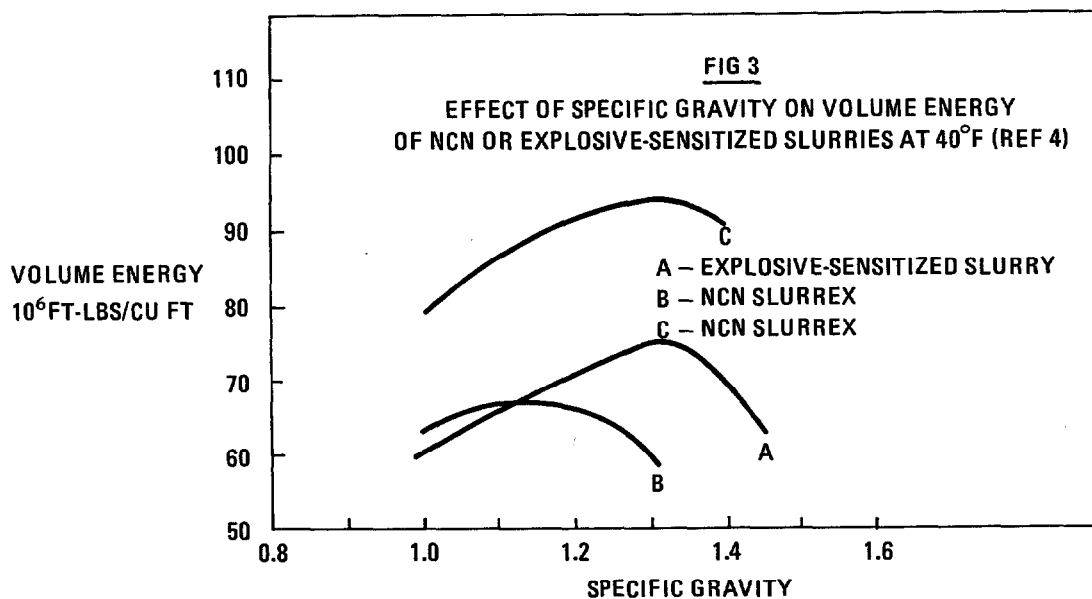

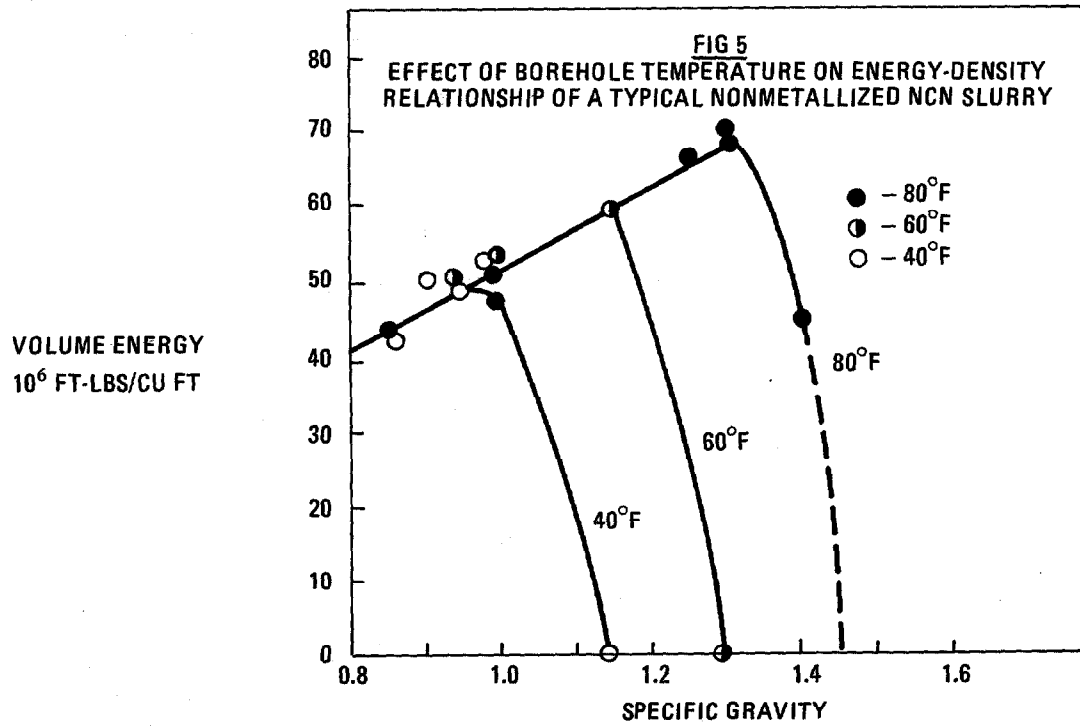
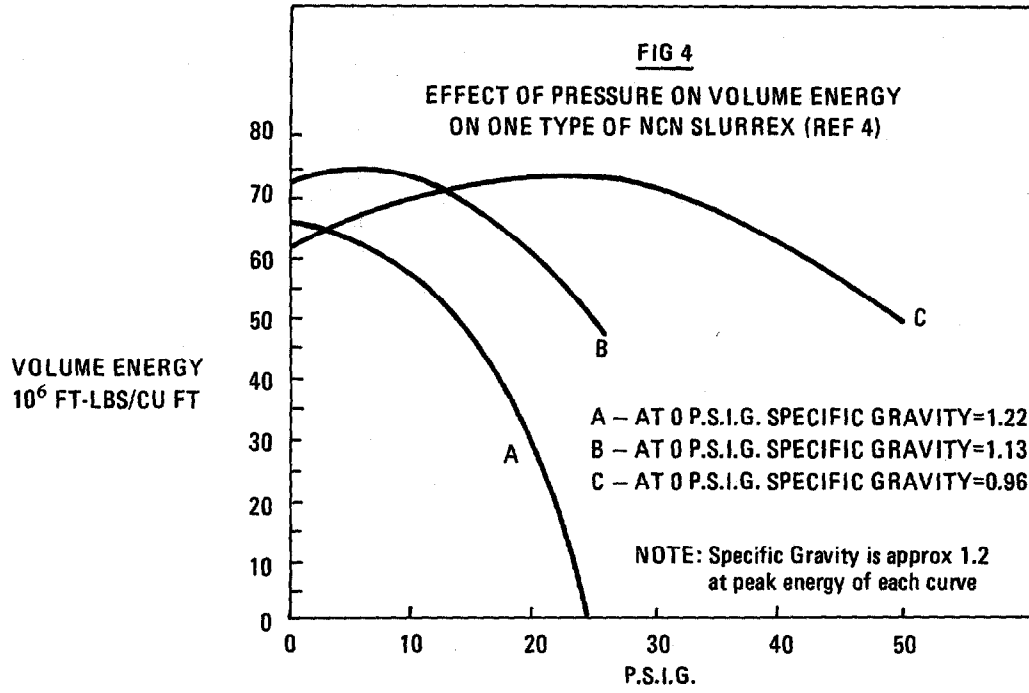

Water content influences Slurry strength.

Dupont Trade Literature claims that each % of w removed increases strength by about as much as the addition of 1% of Al. Cook (Ref 9, p 215) also shows that increase in w content reduces strength. However, according to Cook, this effect disappears in highly aluminized Slurries

As pointed out by Cook (Ref 9, pp 207-10), reaction rate of the exothermic reactions which control Slurry sensitivity and D may be diffusion-controlled. Slurries (and ANFO) differ from conventional military expls because oxidizer and fuel are contained in different molecules in the former and in the same molecule in the latter. Presumably most oxidizer-fuel reactions in Slurries are heterogeneous, ie, gaseous oxidizers from the AN react with solid or liq fuels. Thus diffusion of gaseous oxidizers to fuel sites may be critically important. High packing densities hinder gas diffusion, which in turn may lead to incomplete oxidizer-fuel reaction. For conventional explosives, D increases with packing d. This also occurs in Slurries until packing is so tight that gas diffusion is hindered. These combined effects provide a qualitative explanation for the observed maxima in D vs packing d curves such as the one in Fig 2

The same explanation applies to Fig 3, since on a per-unit-volume basis detonation energy increases as packing d increases, but this is eventually counteracted by incomplete reaction because of hindered oxidizer gas diffusion

The effects of ambient pressure and temp (Figs 4 & 5) are primarily the consequence of reduced sensitivity and will be described later

C Detonation Pressure

Detonation pressures of Slurries are shown in Table 6. They appear to be quite "normal" in that Γ in the equation $P = \rho_0 D^2 / \Gamma + 1$ has values near 3. The range of Γ 's in Table 6 is from 2.6 to 3.2

D Critical Diameter and Sensitivity

Cook has made extensive exptl and theoretical studies of the sensitivity of Slurries. Indeed much of the content of Chapters 5, 6 & 7 of Ref 9 is devoted to this subject. Since we will quote Cook extensively, we will abide by his definitions, and apply the term *sensitivity* to *performance sensitivity*, and the term *precariousness* to *hazard sensitivity*, eg, sensitivity to impact, flame, etc. Obviously the ideal expl has

high *sensitivity* and low *precariousness*

Sensitivity, as defined above, has been characterized by Cook in terms of the minimum booster (MB) required to get consistent detonation of the Slurry, or the critical diameter (d_c) at which unconfined Slurries will detonate consistently when fired with a booster at least twice the size of MB. Usually, Cook describes sensitivity in terms of the reciprocal of d_c , ie, d_c^{-1} . Thus, high values of d_c^{-1} signify high sensitivity and low values, low sensitivity

Some generalizations given by Cook (Ref 9, p 240) are: Expls with d_c greater than 9 inches are too insensitive to be used in commercial blasting. In a borehole whose diam is d_b the critical diam of the expl used should be no greater than $(0.6 \pm 0.2)d_b$

Cook states that MB varies approximately as the inverse of the booster detonation pressure, ie, the higher the detonation pressure of the booster the smaller the size of the booster required to detonate Slurries. A variety of Slurry boosters are now being sold. Most expl manufs make specific recommendations as to the type of boosters to be used with their Slurries

The critical diams of SE and SBA are influenced differently by Slurry d. This is shown in Fig 6 taken from Ref 9. For SBA or even SE that contain no self-expl ingredients, sensitivity (ie, inverse d_c) decreases as Slurry d is increased. Just the opposite effect is observed with SE containing TNT and presumably other self-expl materials. Incidentally, Cook claims that coarse TNT is almost as good a sensitizer as more powerful expls such as Comp B or even RDX

The fact that increased Slurry d does not adversely affect SE sensitivity is further illustrated in Fig 7, which shows the variation of d and sensitivity with w content of a SE containing TNT. Note that max d and sensitivity occur at the same w content. This implies that this SE can be used under high hydrostatic pressures (which will "squeeze" it to high d) which is indeed the case, since it has been shot at a one mile depth in the Pacific Ocean (Ref 5)

Fig 8, which like Fig 7 is taken from Ref 9, shows the variation of SE sensitivity with TNT content and TNT particle size, and compares SE sensitivity to that of dry TNT. Note that d_c^{-1} (sensitivity) is greatest for SE with coarse

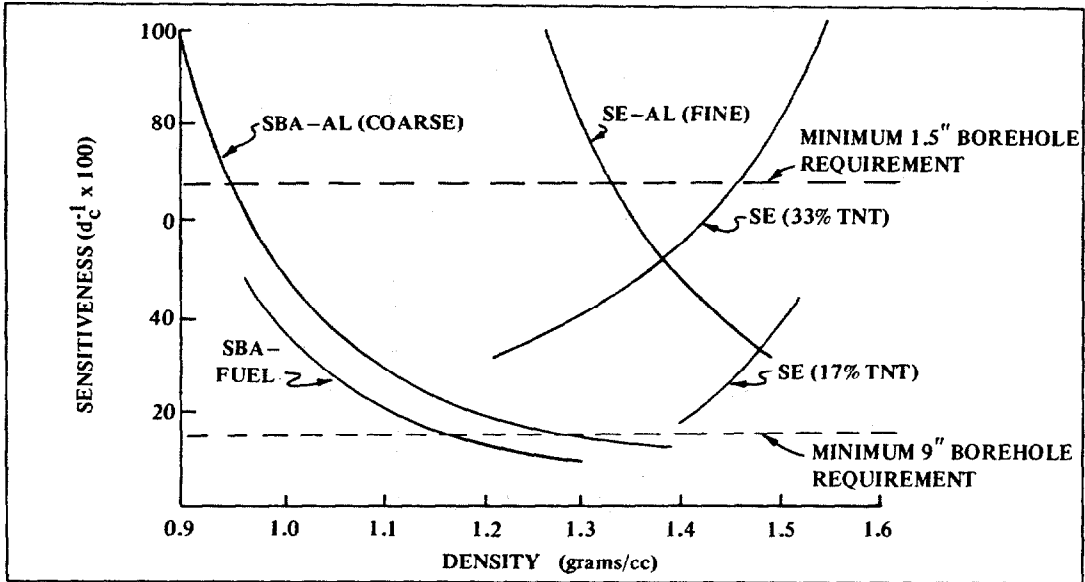

Fig 6 Comparison of Density-Sensitiveness Curves for SE and SBA

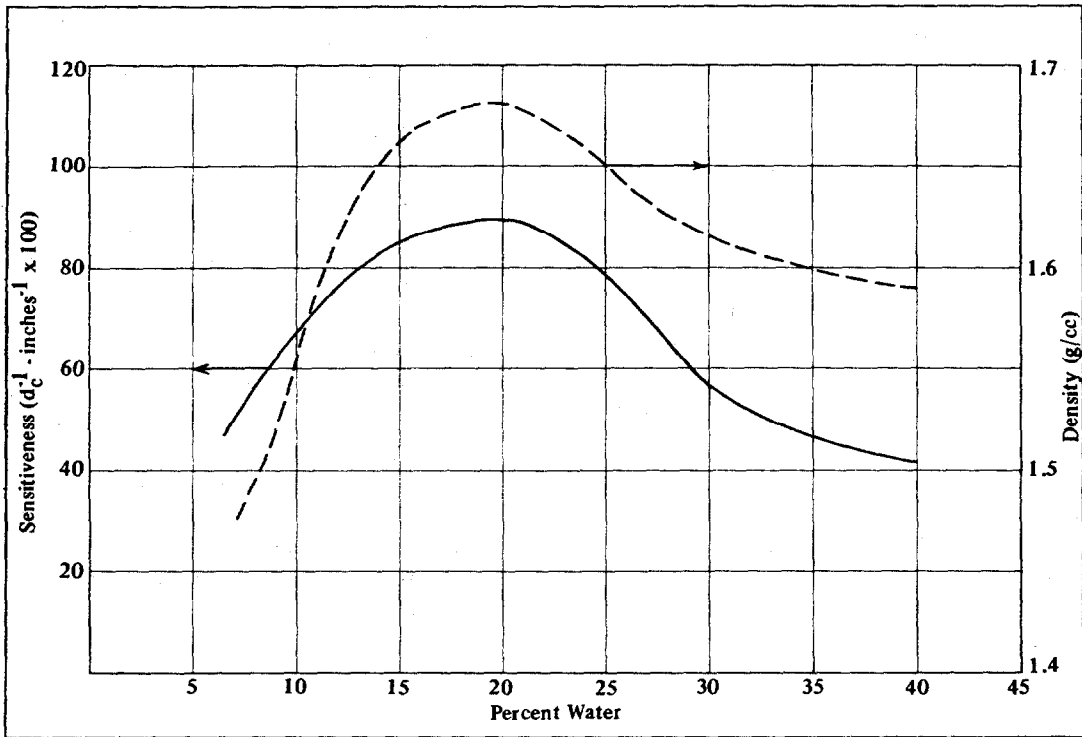

Fig 7 Variation of (gum free) Density and Sensitiveness with Water Content in SE-TNT (33% dry basis - coarse TNT). (Ref 9, p 270)

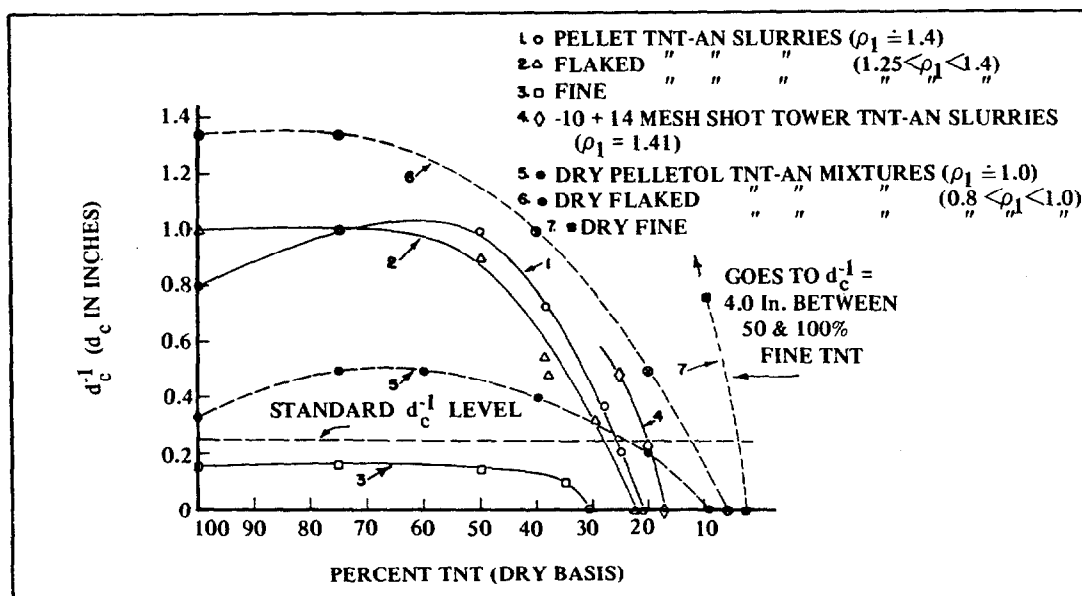

Fig 8 Reciprocal Critical Diameter (or Sensitiveness) vs Percent TNT Curves for SE-TNT (Ref 9, p 269)

TNT and least with fine TNT, whereas just the opposite effect is found for dry TNT or mixts of dry TNT and AN. Possible explanations for this behavior will be examined later

E Adverse Effects of Detonating Cord "Down-Lines"

In large diameter open-pit blasting it is common practice to initiate the expl charge via a booster placed near the bottom of the borehole. Since safety considerations make it undesirable to have blasting caps in the borehole, these boosters are frequently initiated with detonating cord "down-lines", which are themselves initiated by detonating cord "trunk-lines". Such an arrangement requires only a single blasting cap to fire the trunk-lines. Sometimes two separate sets of boosters on two separate sets of down-lines are employed. This redundancy is used to ensure complete detonation of the charge

The use of the above initiation system with SE and SBA has resulted in poor performance and even misfires. The explanation of this degradation as given by Cook (Ref 9, p 227) is as follows: "To understand this problem, realize that the time interval between entrance of the detonation wave into the blasting agent at the top of the charge, the initiation of the booster at the bottom of the charge, and the

return of the actual detonation wave in the blasting agent to the top of the charge may be 3–5msec, more or less, depending on the length of the charge. During this interval several things can happen depending on sensitiveness: (1) If it is sufficiently insensitive the blasting agent may merely be compressed with no chemical reaction occurring in it. This will cause some desensitization and possibly therefore also some sluggishness and possibly incomplete reaction or even deadpressing in the ultimate detonation of the annular material farthest removed when the actual detonation wave returns some few msec later. (2) It may start a deflagration in the blasting agent which may then tend to generate still more sluggishness and even more deadpressing in the annulus around the downlines. The blasting agent may thus then either react incompletely or not at all. (3) It may create a radially propagating either sluggish or possibly even a high-order detonation. Condition (2) is perhaps the worst thing that can happen to the blasting agent, and (3) is the next worst conditon. Condition (1) is the least serious, but apparently even (1) is not without at least some adverse effect on the strength of the blasting agent. Thus any of these effects may deteriorate the main charge to at least some

Table 7
Influence of Detonating Cord Downlines on Energy Release of SBA and ANFO

Test No.	Density (g/cc)	Diameter (inches)		Temperature (°C)	Test ^a	Result ^b
		d	d _c			
SBA-1	1.2	6	3	5	x	100
SBA-2	1.2	6	3	0 5 8 12	x	none 10 50 100
SBA-3	1.2	6	4	5 12 21 24	x	none 10 50 100
SBA-4	1.2	6	4	10 20	x	68 85
SBA-5	1.2	6	4	10	x	59
SBA-6	1.2	6	5	5	x	none (brown fumes)
SBA-7	1.33	12	5	45	x	100
SBA-8	1.33	12	5	5 20	x	none 10 (a), 67 (b)
SBA-9	1.25	6	4	20	x	100
SBA-10	1.33	12	4	20	x	100
ANFO-1	0.8	12	4	20	x	7 (average)
ANFO-2	0.8	12	5	20	x	65 (average)

a - x = point of initiation
 ————— = double 60 gr/ft cord
 - - - - - = double 4 gr/ft cord
 ■ = Procure 3C booster

b - relative energy release

extent so that any effect of this nature may adversely influence the performance of the blasting agent. Apparently only under the unlikely and extreme case of nonsluggish initiation of high-order detonation by the cord can one expect to realize full efficiency in axial initiation such as to produce radial instead of axial propagation. But blasting agents are at the very best only marginally sensitive even to *heavy* detonating cord, as shown above. Hence the effect is apparently always at least some degradation and never an improvement."

An obvious means of overcoming the degradation effect of "down-lines" is to use top initiation and have no "down-lines". Unfortunately, top-hole boosting presents its own set of difficulties, namely difficulty of intimate contact between booster and charge and poorer performance at the bottom of the borehole ("toe") than with bottom-hole boosting

Cook examined the behavior of a number of moderately insensitive Slurries under different conditions of initiation. His results (Ref 9, p 231), as shown in Table 7, clearly demonstrate the deleterious effects of detonating cord down-lines. The solution to the problem is indicated by Tests No SBA 9 & 10. Here the use of Low Energy Detonating Cord (LEDC) at 4 grains/ft expl loading did not degrade the performance of the Slurry. LEDC will reliably initiate regular (50 or 60 gr/ft) detonating cord but will not reliably initiate booster. Thus a short length of regular cord must be attached to the LEDC to initiate the boosters

The energy loss (adverse effect on Slurry performance) is shown graphically in Fig 9 (taken from Ref 12). Note that in large boreholes energy loss is much less severe than in smaller boreholes. In agreement with the result in Table 7, detonating cord with the higher expl loading (designated as 50-grain, 25-grain and 7-grain in Fig 9 but really meant to be grains/ft) has a greater deleterious effect on Slurry performance than detonating cord with low expl loading

Precariousness of Slurries

In general, as pointed out by Cook (Ref 9, p 272), the precariousness (ie, hazard sensitivity) of Slurries is low, primarily because of the heat quenching effect of the Slurries' water content. Thus Slurries are resistant to subsonic impacts

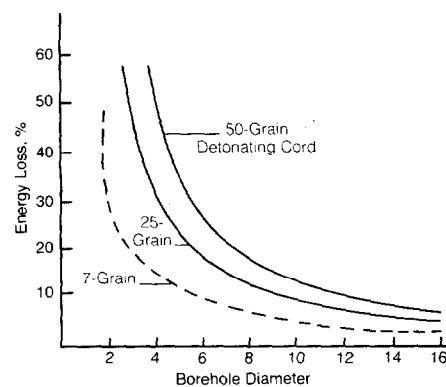

Fig 9 Effect of Detonating Cord on NCN Slurries Potential Energy Loss

and direct flame action. For example, Dupont Trade Literature claims that their Tovex Slurries have been burned as single cartridges, case lots, as partially confined charges in steel pipes, and even as a 10000 pound truckload without detonating. Similarly, Tovex is claimed not to detonate when placed on a steel plate and impacted by a 40 pound steel weight dropped from a height of 15 feet. Gelatin NG Dynamite will detonate in this test

Hercules makes similar claims for their Gel-Power Slurries. Their Gel-Power A SE will not detonate when subjected to the friction of a 560 lb weight moving at 8 ft/sec. Some NG Dynamites will detonate in this test even with a 75 lb weight. This SE will not ignite when subjected to a flame temp of 4900°F for 25 secs. Gel-Power A will not detonate when placed against a vertical steel plate and fired into from 100 feet with either 150-grain ball or 48-grain soft-point ammo

F Fume Characteristics

The products of detonation of commercial expls may include the following non-toxic compds: CO₂, H₂O, N₂, CaCO₃, Na₂CO₃, Al₂O₃ and Na₂SO₄, as well as the following toxic products: CO, oxides of N, H₂S and NH₃. In the case of NG Dynamites, headache-producing fumes may occur both before and after detonation. Slurries contain no NG, consequently they do not have that undesirable feature of NG Dynamites. Furthermore, they appear to generate fewer undesirable fumes (when properly formulated and properly initiated) than Dynamites or ANFO. ANFO in particular is apt to

produce undesirably, or even dangerously, high concns of the highly toxic oxides of N. The US Bureau of Mines (BuMines) standards for max allowable exposure in 8 hours are: CO, 100 ppm and NO₂, 5 ppm

Measurements of the toxic fumes of TNT or Comp B sensitized IRECO Slurries, shot underground, are reported by Cook (Ref 9, p 421). In Table 8, the DBA-3 Slurry was sensitized by Comp B, and the DBA-2 Slurry by TNT. Why DBA-3 produces a much higher concn of oxides of N is not clear to this writer. This effect was confirmed in later series of shots in an iron ore mine, where DBA-3 again produced undesirably high levels of NO and NO₂

BuMines tested several IRECO Slurries in 1970 and 1971. In the earlier test these Slurries (IREMITES) were packaged in polyethylene. As shown in Table 9 (from Ref 9, p 422) they produced appreciable amounts of CO. In the second test in 1971, the oxygen balance of the Slurries was adjusted to zero, taking into account that the polyethylene was part of the fuel (which was not done in the first series). Note the large reduction in CO in the second series. Cook states that in actual practice, ie, shots in boreholes, the polyethylene will not react as completely as it does in the test bombs used in the BuMines measurements

Swedish measurements (quoted by Cook) are in general agreement with the above results, but the reduction in CO and oxides of N does not appear

to be as great for Slurries vs Dynamites as indicated in the IRECO and BuMines tests

The CO and NO content of Slurry detonation products will be largely controlled by the following equilibria:



The extra w initially present in Slurries will drive equilibrium (1) towards CO₂ and H₂. This effect is somewhat counteracted by the reduction in detonation temp because of the quenching action of w contained in the undetonated Slurry. Lower temps mildly favor an equilibrium shift to the left

The w present in the undetonated Slurry should also play a significant role in equilibrium (2). Here lower temps definitely favor the elements rather than the compd (NO). Of course any NO that does not revert to its elements is rapidly oxidized to NO₂ by the O₂ of the atmosphere

G Mechanism of Detonation in Slurries

Before proceeding with a discussion of the detonation mechanism of Slurries, we need to examine briefly the rheology (flow characteristics) of SE and SBA. Any Slurry, whether expl or not, by definition contains suspended solid particles in a continuous liq phase. This liq phase in SE or SBA may be: 1) an unthickened AN (and other oxidizer or even sensitizer) soln; 2) a thickened soln; and 3) a thickened and cross-linked soln. The thickened and/or cross-linked liq phase is a *gel*. An analogy supplied by Cook (Ref 9, p 277) is that pure

Table 8
Fumes from DBA-2 and DBA-3 Taken Immediately After Blast in
Unventilated Mine Near Tooele, Utah, November 1959

SE		CO (%)	CO/CO ₂	NH ₃ (%)	Oxides of Nitrogen
DBA-3	floor	0.043	0.014	0.066	0.057
	middle	0.031	0.012	0.034	0.056
	ceiling	0.011	0.003	0.030	0.030
	average	0.030	0.010	0.043	0.051
DBA-2	middle	0.020	0.01	0.029	4* ppm
	ceiling	0.022	0.01	0.035	20* ppm
	average	0.021	0.01	0.032	12* ppm

*Based on difference between before and after results since the DBA-2 shot followed the DBA-3 shot and all the NO₂ had not disappeared from the DBA-3 shot

Table 9
Data from Bureau of Mines Reports on IREMITE Fume Studies

Data	IREMITE	CO	Oxides of Nitrogen
		(1/kg)	(1/kg)
A September 16, 1970 ^a	IREMITE 40 Bichel gauge	5	none
	Crawshaw- Jones gauge	11.2	1.2
	IREMITE 60 B gauge	14 (1.2) ^b	none
	C-J gauge	11.2 (2.4)	0.2 (0.5)
	IREMITE 80 B gauge	10.5	none
	C-J gauge	8.1	< 0.06
B June 8, 1971	IREMITE 40 B gauge	none	none
	C-J gauge	3.1	2.2
	IREMITE 60 B gauge	none	none
	C-J gauge	3.1	0.7

a - The IREMITES tested by the Bureau of Mines and reported on September 16, 1970, were all slightly negative in oxygen balance, whereas those reported on June 8, 1971, were oxygen balanced at zero (including polyethylene)

b - Results on second (replication) data sheet data shown in ()

clear "Jello" is a *gel*, while "Jello" containing shredded fruit or nuts is a *slurry*

The rheological properties of Slurries are important in many ways. They determine: the pumpability of Slurries; whether there will be segregation of the solid and liq phases (the solid components of Slurries are almost invariably more dense than the liqs); and, probably most important of all, they control the sensitivity and performance of Slurries. Control of Slurry rheology is a highly specialized subject and the reader is referred to Chapter 7 of Ref 9

Closely connected with control of the flow properties of Slurries is control of their density. For a given compn considerable variation in Slurry d can be achieved by: introduction of small amounts of porous solids; by air entrapment (aeration); and by inclusion of small amounts of gas producing ingredients. It is the latter approach (ie, gas-formers) that is

used in most present-day Slurries. In general, gas-formers that produce N_2 are to be preferred. The solubility of N_2 in w solns of AN changes rather slowly with ambient pressure. The solubility of CO_2 (which can be generated in situ rather readily), on the other hand, depends strongly on ambient pressure and the pH of the soln. Oxygen has desirable solubility characteristics but has the potential of reacting prematurely with some of the fuel ingredients

In Section V-D it was shown that Slurry sensitivity and performance depend on Slurry characteristics such as d, particle size of solids and compn, as well as external factors such as pressure and temp. To a considerable degree the effects of internal and external factors can be optimized by control of the rheology and d of Slurries. We shall now examine the rationale behind these control methods

It is well known that low d granular expls

are more shock-sensitive than these same expls packed to a high d. Indeed single crystals of such highly "sensitive" expls as the metal azides are much less shock-sensitive than low d compacts of "insensitive" expls such as TNT. The causes for this behavior are examined in the article on Shock Sensitivity in this Vol. Whatever the cause, the greater sensitivity of Slurries at low packing d is not unexpected

Rather more surprising is the greater Slurry sensitivity achieved with coarse TNT sensitizers rather than fine TNT sensitizers. Even this effect is not unknown with granular expls, but it is less pronounced than with Slurries. A better understanding of this effect may be achieved by examining the behavior of liq expls (see *Liquid Explosives*, Vol 7, L26-R to L34-R). Addition of air bubbles, solid or porous particles is known to increase the shock-sensitivity of liq expls greatly. Usually there is an optimum bubble or particle size for max sensitization. This is indeed the same behavior observed with Slurries containing solid sensitizers and probably an effect that would be observed if gas bubble size can be optimized in Slurries containing gas-formers. Presumably some such bubble-size optimization does occur as a result of d and rheology control

Solid particles or trapped gas bubbles in the Slurry undoubtedly generate *hot spots* at which

intense chemical reaction can occur. There is, however, considerable doubt about the exact nature of these hot spots. Adiabatic compression of gas bubbles is probably relatively unimportant. Formation of microjets (or *sliver* jets as they are called by Cook) thru shock interactions with bubbles or solids may be much more relevant. Shock wave focussing by the solids or bubbles may also contribute to the increase in sensitivity. Whatever the cause, inclusion of bubbles or solids of the proper particle size, uniformly distributed thruout the Slurry, provides a pseudo-continuous distribution of reaction sites thruout the Slurry. Counteracting this effect is the cooling action of the w present in the unreacted Slurry. For this reason it is important to initiate Slurries with a high-intensity shock in order to have the heat-generating effect of the heterogeneous reaction sites overcome the quenching effect of w. Thus booster detonation pressure is more important than booster weight in achieving optimum Slurry performance

VII Patent List

This section presents a list of US patents in descending chronological order. It shows the patent assignee and gives a very brief description of the patent content. Clearly Slurry expls are a very popular subject for patenting since the list contains 134 patents

<u>US Patent No</u>	<u>Assignee</u>	<u>Title</u>
3949673	E.I. duPont deNemours and Company	Semi-Rigid Sinuous Blasting Charge and Borehole Loading Method
3947301	The Dow Chemical Company, Midland, Michigan	Ammonium Nitrate Explosive Composition
3943820	Nitro Nobel AB, Gyttorp, Sweden	Method for Charging Drill Holes with Explosive
3928848	Ireco Chemicals, Salt Lake City, Utah	Blasting Slurry Composition Containing Calcium Nitrate and Method of Preparation
3926698	Ireco Chemicals, Salt Lake City, Utah	Explosive Compositions Containing Metallic Fuel Particles and Method of Preparation Thereof
3925123	Ireco Chemicals, Salt Lake City, Utah	Pourable Aqueous Blasting Composition
3919016	Nalco Chemical Company, Oak Brook, Illinois	Thickening of Solvent Explosives Systems
3864177	The Dow Chemical Company	Safe-Handling Perchlorate Explosives
3839107	The Dow Chemical Company	Calcium Nitrate Explosive Composition

<u>US Patent No</u>	<u>Assignee</u>	<u>Title</u>
3837937	ICI Limited (Great Britain)	Explosive Compositions with Coated Gaseous Encapsulations
3811971	Ireco Chemicals	Method of Blasting Under High Pressure Conditions at Elevated and Normal Temperatures
3787254	Ireco Chemicals	Explosive Compositions Containing Calcium Nitrate
3765967	Ireco Chemicals	Liquid and Slurry Explosives of Controlled High Sensitivity
3728173	Ireco Chemicals	Dense Explosive Slurry Compositions of High Energy Containing a Gum Mixture
3713918	The United States of America as represented by the Secretary of the Interior	Urea Stabilized Gelled Slurry Explosive
3713917	Ireco Chemicals	Blasting Slurry Compositions Containing Calcium Nitrate and Method of Preparation
3713914	Ireco Chemicals	Stiff Aqueous Explosive Composition Containing Gilsonite
3707412	Gulf Oil Corporation	Method of Manufacturing Liquid Phase for Explosive Slurries
3695950	The Dow Chemical Company	Amino-Aldehyde Resin Blasting Composition Containing Gaseous Voids
3695947	Atlas Chemical Industries, Inc	Aqueous Explosive Comprising Higher Amine, Gelling Agent and Inorganic Oxidizer Salt
3690213	The Dow Chemical Company	Method and Apparatus for Delivering Thickened Blasting Agents
3678140	E.I. duPont deNemours and Company	Process for Foaming Aqueous Protein Containing Blasting Agents
3676236	Gulf Oil Corporation	Method of Forming in Place a Gelled Suspension Explosive
3676234	Commercial Solvents Corp	Explosive Slurry Having Constant Detonation Velocity Over a Wide Temperature Range
3674578	E.I. duPont deNemours and Company	Water-In-Oil Emulsion Type Blasting Agent
3668027	Commercial Solvents Corp	Method of Making Nitrocellulose- Nitroglycerin Water-Bearing Explosives Compositions
3661659	E.I. duPont deNemours and Company	Gelled Acidic Explosive Compositions
3660181	Ireco Chemicals	Blasting Slurry Compositions Containing Calcium Nitrate and Method of Preparation
3658607	Ireco Chemicals	High Energy Explosive Compositions and Method of Preparation
3653996	Atlas Chemical Industries, Inc	Controlled Gelation in Aqueous Explosives Containing Boric Acid

<u>US Patent No</u>	<u>Assignee</u>	<u>Title</u>
3653992	Hercules Incorporated	Aqueous Slurry Salt Type
3646844	Ireco Chemicals	Method and Apparatus for Filling Containers with Explosive Slurry
3645809	Hercules Incorporated	Aqueous Slurry Explosives Having Improved Oxidizer-Fuel System and Method of Making
3640784	Monsanto Company	Blasting Agents Containing Guar Gum
3639184	The Dow Chemical Company	Method for Preparing Gelled Slurry Explosive Composition Containing Distinct Liquid and Solid Phases
3637445	Hercules Incorporated	Method for Making Explosive Oil Impregnated Sensitizer Gelled Aqueous Explosive Slurry
3630250	The Dow Chemical Company	Ammonium Nitrate Explosive Composition
3629021	E.I. duPont deNemours and Company	Slurry Explosive Composition Containing Nitrogen-Base Salt and TNT, Smokeless Powder or Composition B
3622408	E.I. duPont deNemours and Company	Water-Bearing Explosives Thickened with a Partially Hydrolyzed Acrylamide Polymer
3619308	Gulf Oil Corporation	Method of Forming in Place a Gelled Aqueous Slurry Explosive
3617407	Canadian Industries Limited	Aqueous Slurry Explosive Containing a Thickener of Cross-Linked Galactomannan with Psyllium Flour
3617404	E.I. duPont deNemours and Company	Slurry explosives Containing the Combination of Nitrogen-Base Salt and Hard Solid Particles as Sensitizer
3617402	Hercules Incorporated	Aqueous Slurry Blasting Composition Containing an Aliphatic Amine Salt and a Water Soluble Inorganic Perchlorate
3610088	Ireco Chemicals	Apparatus and Method for Mixing and Pumping Fluid Explosive Compositions
3586553	E.I. duPont deNemours and Company	Water-Bearing Explosive Containing Protein and Nitrogen-Base Salt
3582411	Ireco Chemicals	Aerated Explosive Slurry Containing a Foam Promoting and Viscosity Increasing Agent and Method of Making Same
3580753	Commercial Solvents Corp	TMETN-Inorganic Nitrate Explosives Blended with Aluminum
3580752	Commercial Solvents Corp	TMETN-Inorganic Nitrate Explosives Blended with Water
3580750	Commercial Solvents Corp	TMETN-Inorganic Nitrate Explosives Blended with Petroleum Oil

<u>US Patent No</u>	<u>Assignee</u>	<u>Title</u>
3546034	Commercial Solvents Corp	Ammonium Nitrate-Nitromethane Type Blasting Agent Containing Urea as a Crystallization Inhibitor
3523841	Hercules Incorporated	Aqueous Slurry Type Blasting Composition Containing a Densified Nitrocellulose Sensitizer
3523048	Hercules Incorporated	Bulk Delivery of Crosslinkable Aqueous Slurry Explosive with Crosslinking Agent in a Separate Feed
3522117	E.I. duPont deNemours and Company	Aerated Water-Bearing Inorganic Oxidizer Salt Blasting Agent Containing Dissolved and Undissolved Carbonaceous Fuel
3519370	ICI Limited (Great Britain)	Aqueous Explosive Composition Containing as a Sensitizer a Condensation Product of Ethylene Oxide with a Phenol or Saturated Carboxylic Acid
3507718	Ireco Chemicals	Explosive Slurry Containing Pulpy Fibrous Matter, Finely Divided Carbonaceous Material and Powerful Inorganic Oxidizer Salt
3504628	Ireco Chemicals	Packaging for Slurry Explosives
3496040	Gulf Oil Corporation	Aqueous Ammonium Nitrate Slurry Explosive Compositions Containing Hexamethylenetetramine
3489623	Commercial Solvents Corp	Process of Gelling TMETN Nitrocellulose Explosives Using Nitroparaffin Solvents and TMETN Nitrocellulose Explosive Gels
3485686	Ireco Chemicals	Aqueous Explosive Slurry Containing Oxidizer-Reducer Cross-Linking Agent
3473983	Ireco Chemicals	Slurry Blasting Composition Containing Sulfur and Having High Sodium Nitrate Content
3471346	E.I. duPont de Nemours and Company	Fatty Alcohol Sulfate Modified Water-Bearing Explosives Containing Nitrogen-Base Salt
3470041	Atlas Chemical Industries, Inc	Nitric Acid Sensitized Cap Sensitive Explosives with Gelation Catalyst and Entrapped Air
3462324	The Dow Chemical Company	Explosive Composition Comprising a Salt Component Contiguous to an Over-Fueled Salt Component
3457128	Commercial Solvents Corp	Safe Aqueous Slurries of Particulate Nitrated Explosives and Polyacrylamides
3475127	Ireco Chemicals	Explosive Composition Containing an Additional Product of Urea and Nitric Acid and Method of Preparing Same

<u>US Patent No</u>	<u>Assignee</u>	<u>Title</u>
3475126	ICI Limited (Great Britain)	Aqueous Explosive Composition Containing a Porous Water Insoluble Synthetic Organic Polymeric Cellular Material
3456589	The Dow Chemical Company	High Pressure Explosive Compositions and Method Using Hollow Glass Spheres
3455750	Hercules Incorporated	Nonaqueous Inorganic Oxidizer Salt Blasting Compositions Containing Silicon Component of Particular Size
3453158	Ireco Chemicals	Fueled Inorganic Oxidizer Salt Aqueous Explosive Compositions Containing Independently Dispersed Gas Bubbles and Method of Making Same
3451868	E.I. DuPont de Nemours and Company	Water-Bearing Explosive Compositions Gelled with Polymeric Amide-Aldehyde and Method of Making Same
3451341	Hercules Incorporated	Booster Structure
3449181	Hercules Incorporated	Aqueous Slurry Type Explosive Containing the Combination of Nitrite and Sulfamate and/or Sulfamic Acid as Aeration Agent
3447979	Atlas Chemical Industries, Inc	Gelled Nitric Acid Blasting Composition and Method of Preparing Same
3447978	Atlas Chemical Industries, Inc	Ammonium Nitrate Emulsion Blasting Agent and Method of Preparing Same
3445305	E.I. duPont de Nemours and Company	Gelation of Galactiomannan Containing Water-Bearing Explosives
3444014	E.I. duPont de Nemours and Company	Gelled Aqueous Nitric Acid Composition and Method of Making Same
3442729	Hercules Incorporated	Aqueous Inorganic Oxidizer Salt Explosives and Acrylamide Polymers as Thickener Therefor
3442727	Atlas Chemical Industries, Inc	Emulsified Nitric Acid Blasting Composition and Method of Preparing Same
3437038	Hercules Incorporated	Process and Assembly for Manufacture of Cast Boosters and Booster Product
3437037	Hercules Incorporated	Fuse Type Initiator and Booster System Containing Same
3432371	The Dow Chemical Company	Dry Explosive Composition Containing Particulate Metal of Specific Mesh and Gauge
3431848	Hercules Incorporated	Explosive Cartridge Assemblies
3431155	E.I. duPont de Nemours and Company	Water-Bearing Explosive Containing Nitrogen-Base Salt and Method of Preparing Same
3431154	Canadian Industries Limited	Aqueous Slurry Explosive Composition Containing a Chlorinated Organic Compound as Sensitizer

<u>US Patent No</u>	<u>Assignee</u>	<u>Title</u>
3419444	Commercial Solvents Corporation	Thickened Aqueous Inorganic Nitrate Salt-Nitroparaffin Explosive Composition Sensitized with an Air Entrapping Material
3409486	Gulf Oil Corporation	Thickened Aqueous Ammonium Nitrate-Hexamethylenetetramine Explosive Containing Ammonium Perchlorate as Sensitivity Stabilizer
3409485	Commercial Solvents Corporation	Thickened Inorganic Oxidizer Salt Slurried Explosive Containing Tri (Hydroxymethyl)- Nitromethane and Air-Entrapping Material
3409484	Commercial Solvents Corporation	Thickened Inorganic Oxidizer Salt Slurried Explosive Containing an Alkyl-amine Nitrate and an Air Entrapping Material
3406051	E.I. duPont de Nemours and Company	Aqueous Explosive Compositions Containing a Partially Nitrated Aromatic Hydrocarbon Dispersed by a Monoamide
3401067	Hercules Incorporated	Aqueous Slurry Type Explosive Compositions Sensitized with at Least One Alkanol-amine Nitrate
3400026	E.I. duPont de Nemours and Company	Thickened Aqueous Inorganic Oxidizer Salt Explosive Composition Containing Dissolved Proteinaceous Material
3397097	E.I. duPont de Nemours and Company	Thickened Aqueous Inorganic Oxidizer Salt Blasting Compositions Containing Gas Bubbles and a Crystal Habit Modifier and Method of Preparation
3397096	Canadian Industries Limited	Thickened Inorganic Oxidizer Salt Explosive Slurry Sensitized with a Soluble Polyflavonoid
3390032	Hercules Incorporated	Gelled Aqueous Slurry Explosive Composition Containing as a Gas Generating Agent a Carbonate or Bicarbonate with a Nitrite
3390031	Hercules Incorporated	Gelled Aqueous Slurry Explosive Composition Containing an Inorganic Nitrite
3390030	Hercules Incorporated	Aqueous Slurry Blasting Composition of Non-Explosive Ingredients Containing Silicon and an Aeration Agent
3390028	Hercules Incorporated	Aqueous Slurry Blasting Explosive Containing Silicon and an Aeration Agent
3383252	Commercial Solvents Corporation	Nitro-Paraffins Thickened with N-COCO-Hydroxybutyramide
3382117	Ireco Chemicals	Thickened Aqueous Explosive Composition Containing Entrapped Gas

<u>US Patent No</u>	<u>Assignee</u>	<u>Title</u>
3380333	Ireco Chemicals	System for Mixing and Pumping Slurry Explosives
3379586	Commercial Solvents Corporation	Gelled Ammonium Nitrate--Nitromethane--Nitropropane Explosive Composition
3379587	Ireco Chemicals	Inorganic Oxidizer Salt Blasting Slurry Composition Containing Formamide
3378415	Commercial Solvents Corporation	Explosive Slurry Containing an Agglomerate of an Inorganic Nitrate Oxidizer and a Fuel and Method of Making
3378235	Ireco Chemicals	System for Producing a Blended Fluid Explosive Composition
3377218	Commercial Solvents Corporation	Gelled Ammonium Nitrate--Nitroethane Explosive Composition
3377217	Commercial Solvents Corporation	Gelled Ammonium Nitrate--Nitromethane Explosive Composition
3376176	Atlas Chemical Industries, Inc	Aqueous Inorganic Nitrate Salt Slurry Containing Nitric Acid and Entrapped Air
3372072	E.I. duPont de Nemours and Company	Gelling Water-Bearing Explosives
3371606	Ireco Chemicals	Explosive Booster for Relatively Insensitive Explosives
3369945	Canadian Industries Limited	Explosive Composition Containing an Inorganic Oxidizer Salt, a Soluble Ligno-sulfonate, and Mutual Solvent Therefor
3361023	Ireco Chemicals	System for Pumping Slurry or Gel Explosives Into Boreholes
3356545	Hercules Incorporated	Aqueous Slurry Type Nitrocarbonitrate Blasting Compositions Containing Flake Aluminum--Dinitro--Toluene as the Only Sensitizer
3356544	Hercules Incorporated	Inorganic Oxidizer Salt Aqueous Blasting Compositions Containing a Nitroparaffin
3355336	E.I. duPont de Nemours and Company	Thickened Water-Bearing Inorganic Oxidizer Salt Explosive Containing Cross-linked Galactomannan and Polyacrylamide
3350246	Hercules Incorporated	Aqueous Inorganic Oxidizer Salt Blasting Compositions Containing Tamarind Seed Powder
3341382	Ireco Chemicals	Boosters for Relatively Insensitive High Ammonium Nitrate Explosives
3338165	Commercial Solvents Corporation	Gelled Nitromethane Explosive Containing Fluid Encapsulations
3333998	Hercules Incorporated	Aqueous Blasting Compositions Containing Flake Aluminum and Sugar

<u>US Patent No</u>	<u>Assignee</u>	<u>Title</u>
3331717	Ireco Chemicals	Inorganic Oxidizer Blasting Slurry Containing Smokeless Powder and Aluminum
3328217	Hercules Incorporated	Aqueous Blasting Compositions Containing Particulate Smokeless Powder and Dinitrotoluene
3318740	Hercules Incorporated	Aqueous Slurry-Type Blasting Compositions Containing a Hexamethylene-Tetramine Nitrate Sensitizer
3312578	Canadian Industries Limited	Slurried Blasting Explosives with Cross-Linking Delay Agent
3307986	The Dow Chemical Company	Ammonium Nitrate-Alkali Metal Nitrate Explosive Containing Aluminum of Particular Size Distribution
3303738	Ireco Chemicals	Method for Mixing and Pumping of Slurry Explosive
3288661	Hercules Incorporated	Aerated Aqueous Explosive Composition with Surfactant
3288658	Hercules Incorporated	Aerated Explosive Compositions
3282753	Ireco Chemicals	Slurry Blasting Agent Containing Non-Explosive Liquid Fuel
3282752	Ireco Chemicals	Slurry Type Blasting Agent
3275485	Commercial Solvents Corporation	Ammonium Nitrate Slurry Sensitized with Nitro substituted Alkanols
3261732	Hercules Incorporated	Aqueous Slurry Blasting Agent Containing Aluminum and an Acetic Acid-Zinc Oxide Stabilizer
3256181	The Dow Chemical Company	Method of Mixing a Pumpable Liquid and Particulate Material
3249477	Ireco Chemicals	Ammonium Nitrate Slurry Blasting Composition Containing Sulfur-Sodium Nitrate Sensitizer
3249476	Ireco Chemicals	Composition of Low Crystallization Point and Method of Preparation
3249474	Ireco Chemicals	Explosive Composition Containing Inorganic Salts and Coated Metal
3242019	Atlas Chemical Industries, Inc	Solid Emulsion Blasting Agents Comprising Nitric Acid, Inorganic Nitrates, and Fuels
3235425	Hercules Incorporated	Slurry-Type Blasting Compositions Containing Ammonium Nitrate and Smokeless Powder
3235424	Hercules Incorporated	High Density Water-Containing Blasting Materials Containing Ferrosilicon and Ammonium Nitrate
3235423	Hercules Incorporated	Stabilized Aqueous Slurry Blasting Agent and Process

<u>US Patent No</u>	<u>Assignee</u>	<u>Title</u>
3212438	Hercules Incorporated	Priming Device for Blasting Compositions
3214307	Commercial Solvents Corporation	Ammonium Nitrate Explosive Gel Composition and Its Preparation
3202556	E.I. duPont de Nemours and Company	Method for Gelling Water-Bearing Explosive Compositions Containing Galactomannan Gums
3190777	E.I. duPont de Nemours and Company	Fluidizing Agents for Water-Bearing Explosive Compositions
3164503	Atlas Chemical Industries, Inc	Aqueous Emulsified Ammonium Nitrate Blasting Agents Containing Nitric Acid
3161551	Commercial Solvents Corporation	Ammonium Nitrate-Containing Emulsion Sensitizers for Blasting Agents
3160538	Commercial Solvents Corporation	Aqueous Explosive Gel Composition and Process
3155554	Ireco Chemicals	Liquid Blanketed Chlorate Blasting Agent
3153606	E.I. duPont de Nemours and Company	Aqueous Explosive Composition Containing Flake Aluminum and Ammonium Nitrate
3121036	Ireco Chemicals	Explosive Composition Comprising Ammonium Nitrate and a Heat-Producing Metal
3113059	Ireco Chemicals	Inhibited Aluminum-Water Composition and Method
3108917	Canadian Industries Limited	TNT-Tetraborate Gelled Aqueous Explosive Slurry
3096223	Ireco Chemicals	Slurry Blasting Explosives Containing Inorganic Perchlorate or Chlorate
3094443	The Dow Chemical Company	Ammonium Nitrate Explosive Composition
3091559	The Dow Chemical Company	Ammonium Nitrate Explosive Composition
3072509	E.I. duPont de Nemours and Company	Gelled Ammonium Nitrate Blasting Explosive and process

Written by: J. ROTH

Refs: 1) J.F.C. Dixon, Proc Missouri School of Mines Symp on Mining Research, 124 (1960)
 2) M.A. Cook, Science **132**, 1105 (1960) 3) M.A. Cook, SkillingsMiningRev **49**, 3 (1960) 4) C.W. Eilo, Explosives Engineer, No 1, 14 (1968)
 5) D.W. Kos & J.E. Kennedy, IIT Report, Contract DA-49-083-OSA-3198 (ARPA) (1969) 6) I. Ito et al, JIndustExplSocJapan **32**, 70 (1971)
 7) I. Ito et al, Ibid, 79 (1971) 8) H.H. Reed,

TID-4500, UC-35, USArmyEngWaterwaysExp-Station, Livermore (1974) 9) M.A. Cook, "The Science of Industrial Explosives", Graphic Service & Supply, IRECO Chemicals, Salt Lake City, Utah (1974) 10) M. Finger et al, 6th-ONRSymp, 729 (1976) 11) S. Levmore & R.T. Schimmel, TechRept **ARLCD-TR-78010** (1978) 12) B. Burke, Explosives Engineer, No 1, 15 (1978)

Small Arms and Small Arms Ammunition. See under "Ammunition and Weapons or Arms" in Vol 2, A383-L to A391-L

Addnl Refs: 1) Anon, "Ammunition, General", **TM 9-1300-200** (1969) 2) D.E. Archer, Ed, "Jane's Infantry Weapons-1977", Franklin Watts, NY (1977), 3-9, 9-65, 113-247, 369-400 3) I.V. Hogg & J. Weeks, "Military Small Arms of the 20th Century", Hippocrene Books, NY (1977) 4) E.C. Ezell, "Small Arms of the World", Stackpole Books, Harrisburg, Pa (1977)

Small Scale Gap Tests. See under "Influence Tests" in Vol 7, I98-R to I100-R

Addnl Ref: Anon, *EngrgDesHndbk*, "Explosives Series-Explosive Trains", **AMCP 706-179** (1974), pp 3-4 to 3-11

"Smart" Bombs. There are two types of smart bombs currently in use by the USAF - the laser guided bomb first introduced in southeast Asia in May 1968, and electro-optically (EO) or *HOBO* bombs which entered service in that theatre in February 1969. The former type of munition is used in 500, 2000 and 3000-lb categories, and the EO bomb is produced in 2000- and 3000-lb sizes

The laser guided type consists of a conventional bomb in which are added stabilizer fins, a computerized directional package in place of the normal fuze, and a guidance module containing a laser seeker. The EO bomb has strakes running the length of the weapon and control surfaces at the rear, with a TV guidance module at the front. A monitor in the aircraft is used by the crew for initial target acquisition, and after lock-on by the bomb's camera has been confirmed the weapon can be released, after which the guidance module steers the bomb to the target automatically. The laser guided versions are reported to cost \$3100 each, and the EO versions \$13000 each

In the latter half of 1972 the USAF, with industry, instituted studies of possible ways of further enhancing the smart bomb concept by the provision of blind attack facilities and extending the effective range to permit "stand-off" operations. Because smart bombs, EO or laser directed, are capable of only modified ballistic

trajectories, effective stand-off ranges cannot be achieved under all conditions. The latest development overcomes this objection by providing the bomb with wings that are sprung into the flight position after the release from the parent aircraft. The bomb is thus given increased range by the ability to glide into the target area. The Celesco industries modification kit includes, in addition to the wings, an autopilot to control the bomb until the terminal homing system takes over

Ref: R.T. Pretty, Ed, "Jane's Weapon Systems-1977", Franklin Watts, NY (1976), 153-54

Smith's Explosives. Expls patented in 1905 suitable for blasting purposes or as shell fillers: 1) AN 82, Zn powder 10, petrolatum 5, and asphaltum varnish 3%; 2) K perchlorate 53, Amm perchlorate 18, sulfur 5, Zn powder 8, petrolatum 5, asphaltum varnish 3, alc 6, and benz 2p
Ref: *Guia, Trattato 6* (1959), 398

Smoke, Military. See under "Pyrotechnics" in Vol 8, P507-L to P508-R (Colored and White Smoke, Screening Smoke, Signal Smokes)

Smokeless Powder. See under "Propellants, Solid" in Vol 8, P402-L to P413-R

"Smokeless Powder Dynamite". Prepd by mixing ground smokeless powder 15-20 with Na nitrate 0-40, AN 6-67, TNT 1-15, NG 0.25-2, and woodpulp 0-2p
Ref: L.H. Jones, USP 1447248 (1923) & CA 17, 1717 (1923)

Smolianinoff. Patented a Dynamite called "Americanite" in 1890 (see Vol 1, A168-L)

Snake. 1) A mine-clearing device developed by the Allies during WWII. It consisted of a long pipe or tube filled with expls which would be pushed onto a minefield and there expld. 2) A post-WWII refinement in which a 100 ft-long rail-like device is propelled across a minefield by

a 4.5" rocket. On the rail are mounted HEs which, as they are detonated, clear a path

Refs: 1) Anon, "Demolition Materials", **TM 9-1375-200** (1964), 93-126 2) J. Quick, "Dictionary of Weapons and Military Terms", McGraw-Hill, NY (1973)

Snake-holing. Blasting method for removing deeply buried boulders or rocks. It consists of digging a hole under the boulder and placing a Dynamite charge immediately below it. As the expl charge is confined by the earth, when detonated, it will exert sufficient force on the boulder and will roll it out of place. If sufficient charge is used, it will break the boulder into fragments

Some blasters prefer to use just enough expl to roll the boulders out by snake-holing, and subsequently break them up by "mudcapping" (see Vol 8, M160-R)

Also see under "Blockholing" in Vol 2, B216-L

Refs: 1) Blasters' Hndbk (1969), 383 2) C.E. Gregory, "Explosives for North American Engineers", Trans Tech Publications, Cleveland, Ohio (1973), 236-37

Snelling, Walter O. (1880-1965). Amer chemist specializing in expls, but also known for his many contributions to the liq petroleum gas industry. Dr. Snelling was at the US BurMines from 1908-1916, where he devised the first *Sand Test* (Refs 1 & 3) (See Vol 1, XXI-XXII). He then became the Director of Research at the Trojan Powder Co in 1917 where he worked extensively with Nitrostarch expls. Dr. Snelling was issued over 200 US patents contg many improvements in military and mining expls (Refs 4 & 5)

Refs: 1) W.O. Snelling, ProcEngSocWestern Pennsylvania **28**, 673 (1912) 2) C. Hall, W.O. Snelling & S.P. Howell, "Investigations of Explosives Used in Coal Mines", US BurMines Bull **15**, Washington (1912) 3) Davis (1943), 422-24 4) Marquis' "Who's Who in America" **33**, 1880, Chicago (1964-65) 5) Anon, Ordn **50**, No 273 (1965), 333

Snyder Explosive. A gelatinous material, patented in the US in the 1890's, contg about 94p NG, 6p sol NC, plus some camphor. This expl was evaluated as a bursting charge in US 152mm shells, using 4.5kg per shell, and proved to be extremely powerful and brisant. It was used in the Span-Amer War, and was adopted by Turkey as a bursting charge in several of their shells. Unfortunately, it was too sensitive to impact, resulting in many in-bore prematures

Ref: Daniel (1902), 719

Soap, Mercury Fulminate Indicating. A soap contg triethanolamine and diphenylthiocarbazonone was patented for the removal of MF from skin surfaces. The soap is yellow in color, and changes to purple in the presence of Hg salts

Ref: H.S. Mason & I. Botvinik, USPublHealth-ServRept **58**, 1183-86 (1943) & CA **37**, 6482 (1943)

Sobrero, Ascanio (1812-1888). The discoverer of Nitroglycerin (NG) (see Vol 6, G99-R). Sobrero qualified as a physician and surgeon, but later studied chemistry in Turin, Paris, and Giessen. In 1849 he returned to Turin as Professor of Applied Chemistry in the Technical Institute, later becoming Professor of Pure Chemistry as well. He retired in 1882

His numerous publications cover a wide area of pure and applied chemistry, but he is only remembered for his discovery (1846) of the highly expl glycerol trinitrate ("piroglycerina", later "nitroglycerin"). At the time, the substance was far too dangerous to make on a large scale; but much later (1863) in the hands of Alfred Nobel (see Vol 8, N165-R to N167-L), it became the foundation of the modern expls industry

Refs: 1) A. Sobrero & M. Pelouze, L'Institut **15**, 247 (1847) & Ann **64**, 398 (1848) 2) M. Guia, "The Achievement of Ascanio Sobrero", Gazz **89**, 3-8 (in Ital) & 9-14 (in Engl) (1959)

Soda Blasting Powder. BlkPdr contg Na nitrate. See Vol 2, B172-R to B173-L

Soda Dynamites. Dynamites contg Na nitrate as the chief ingredient. The first formulations of this type were prepd in 1873 by the British Dynamite Co Ltd (later to become Nobel's Explosives Co, Ltd). They contained 70–75% Na nitrate, about 15% NG and 7–17% paraffin and charcoal dust. Due to the high hygroscopicity of Na nitrate, these expls were rejected by the Brit military authorities

Similar expls were used, however, later for commercial purposes, viz, Rhexite in Austria, and Atlas Powder B, Judson Powder and Vigorite in the USA. Many Gelatine Dynamites also contain Na nitrate as their primary ingredient

See under "Dynamite and Substitutes" in Vol 5, D1584-L to D1616-R
 Ref: Daniel (1902), 823–24

Sodatol. An expl mixt contg Na nitrate 55–60 and TNT 45–40%. Ref 1 states that it was used for agricultural purposes and was as powerful as 40% Dynamite. Stettbacher (Ref 2) claims it was used during WWI in Germany and Russia, and that the 55/45 formulation was suitable for loading bombs and shrapnel shells

Refs: 1) A.J. Adams, *MichAgrExptStaQuart Bull* 6, No 2, 52–53 (1922) & CA 18, 2812 (1924) 2) Stettbacher (1933), 277 3) Anon, OSRD 3156 (1944), last section, p 6

SOD Formula 122. A Na stearate thickened gasoline having the following compn: stearic acid 3.4, rosin 1.8, cottonseed oil (castor oil) 3.0, caustic soda 1.1, w 2.2, and motor gasoline 88.5%. It was prepd by taking 1/2 of the gasoline, No 2 kerosene, fuel oil or a combination of these, and adding the stearic acid, rosin and cottonseed oil. To the other portion, the required amt of caustic soda dissolved in 95% ethyl alc was added. The two mixts were poured together, resulting in solidification

Ref: A.E. Gaul & L. Finkelstein, "History of Research and Development of the Chemical Warfare Service in World War II", Vol 18, Pt 3 (1952), 113

Sodium and Its Derivatives

Sodium. See in Vol 8, P502-L to P504-R under "Pyrophoric Incendiary Agents"

Sodamide. See in Vol 1, A170-L

Sodium Acetate. See in Vol 1, A29-L

Sodium Acetylde. See in Vol 1, A82-L under "Monosodium Acetylde or Sodium Hydrogen Acetylde"

Sodium Azide. See in Vol 1, A601-R to A619-R under this title plus the following *Addnl Refs*:
 1) Anon, "Sodium Azide, Technical", MIL-S-20552A (24 July 1962) 2) S. Oinuma & Y. Mizushima, JapP 74135900 (1974) & CA 83, 63052 (1975) [In this patent it is claimed that laminated expl sheets can be prepared by incorporating azides such as Na Azide which are insensitive to friction or impact. The first of two laminar sheets (of 1.2mm thickness) is prepd by dissolving 3g of butyral resin (78 to 84% butyral) in 30ml of acet and 7ml of 2,3-butanediol, and then mixing with 5g of Na Azide and 5g of powdered filter paper. The mixt is then poured onto a 130cm² sheet of polyethylene and stored in a desiccator over CaCl₂. The second laminar sheet (of 1.3mm thickness) is then similarly prepd with the addn of 12g of Pb acetate to the mixt before pouring. The sheets are then cut to desired size and joined together using a mixt of butyral resin 3g, acetamide 10g, acet 30ml and 2,3-butanediol 7ml as a glue. The acet is evapd off, the sheets soaked in w for one day and then dried] 3) T. Shiki et al, "Propellant Tablets Having Good Strength and Uniform Weight", JapP 7573885 (1975) & CA 84, 107996 (1975) [In this patent it is suggested that when powdered Na Azide is mixed with K Perchlorate, wetted with organic solvents such as methyl benzene and then extruded thru suitable perforated plates on strainers, the result will be tablets which have 2.0–2.5kg/cm² compressive strength and wts of 89 ± 3mgs] 4) K. Hattori

& T. Fukuda, "Propellant for Automatic Safety Bag", JapP 7656789 (1976) & CA 85, 80517 (1976) [The inventors claim in this patent that by mixing 60–90% Na Azide (of 5–40 micron particle diam) with 10–40% of neutral or weakly alkaline Mn oxide (of 5–40 micron particle diam) a propnt is produced which, when compacted at 500kg/cm² into a cylinder and inhibited with an epoxy resin impregnated glass cloth cover, can be ignited at 400°, and exhibits a linear burning rate of 1.05mm/sec evolving 470cc of propnt gas/g. The inventors also claim that the propnt can be stored at 100° for 100 days without deterioration] 5) H.D. Fair & R.F. Walker, Eds, "Energetic Materials-1; Physics and Chemistry of the Inorganic Azides", Vol 1, Plenum, NY (1977), 33–36 (props & methods of prepn), 88–89 (cryst growth), 103–04 (cryst structure), 151–55 (intermolecular vibrations), 213–49 (ionic character & stability, electronic structure), and 292–96 (imperfections & radiation-induced decompn) 6) Ibid, "Energetic Materials-2; Technology of the Inorganic Azides", Vol 2, Plenum, NY (1977)

Sodium Azido Thiocarbonate. See in Vol 1, A634-R

Sodium Carbide. See in Vol 1, A82-L under "Disodium Acetylide or Sodium Carbide"

Sodium Carbonate and Bicarbonate. See in Vol 2, C59-L to C60-R under "Sodium Bicarbonate and Carbonate"

Sodium Carboxy Methyl Cellulose. See in Vol 2, C65-R under "Carboxy Methyl Cellulose" plus the following *Addnl Ref*: M. Baer, "Production Engineering On RD-1333 Lead Azide", PATR DB4-60 (1960) [Baer reports that since space limitations in small vol detonators such as the M47 do not allow a sufficient amt of dextrinated Pb Azide to be used which will consistently initiate expls such as RDX high order, an alternative initiator processing technique was sought. The sought-after alternative process was found in an expl coating technique developed

in Engl by the British Ministry of Supply at Waltham Abbey in 1949–53, using Na carboxy-methyl cellulose (NaCMC) as the nucleating agent plus a surface active agent to disperse the coating over the expl's surface. The success of this alternative process, concludes Baer, is due to the increase in the amt of the azide which can be vol loaded (from 92% with dextrinated coating to 97% min using the developed technique), and the non-hygroscopicity afforded by the NaCMC coating]

Sodium Cellulose Glycolate. See in Vol 3, C351-R under "CMC"

Sodium Chlorate. See in Vol 2, C197-R to C200-R

Sodium Chloride. See in Vol 3, C241-L

Sodium Chlorite. See in Vol 3, C246-L

Sodium Chromate. See in Vol 3, C282-L

Sodium Decaborane. See in Vol 2, B253-R to B255-R under "Boron Hydride Derivatives and Fuels"

Sodium Dichromate. See in Vol 3, C287-L

Sodium Hydrazide. See in Vol 7, H189-R under "Hydrazide"

Sodium Nitrate. See in Vol 8, N36-R to N38 (tables) and the following *Addnl Refs*: 1) M. Gilford et al, "Thermal Parameters Associated with the Ignition of the Magnesium-Sodium Nitrate System", PATN-27 (1958) [The variability of the ignition temp of the Mg-Na nitrate pyrot system prevented the investigators from measuring the activation energy of the system. The problem was solved by the use of a thermal

blanket consisting of Al oxide. Using this technique the authors report an activation energy of 45.7kcal/mole for the Mg-Na Nitrate system, a value which was found to be substantially independent of the variations in system compn and Mg particle size] 2) D.E. Middlebrooks & S.M. Kaye, "The Effects of Processing on Pyrotechnic Ingredients Part 1: Compressibility of Powdered Magnesium and Sodium Nitrate at Consolidated Pressures to 10,000 psi", PATR **3252** (1965) [The authors report that no irregularities in permeability, porosity or particle size which would cause non-reproducibility of the illuminance and burning rate characteristics of the Mg-Na nitrate system could be attributed to consolidation at pressures to 10,000 psi. To eliminate operator errors in the pressing of pyrot compns the authors recommended installation of automated pressing equipment. The only other area that was felt to be a source of error was that the specifications allowed major differences in the particle size distribution of substituents prior to incorporation into compns. The authors recommended that future reproducibility studies be focused on control of particle size distribution of pyrot ingredients] 3) R.A. Dick, "Factors in Selecting and Applying Commercial Explosives and Blasting Agents", **USDI-BM-8405** (1968), 13-19 [A summary of both comml and mil blasting agent properties such as "weight strength", "cartridge strength", specific gravity, confined velocity, water resistance, "fume class", etc. Included in the compilation are various compns contg Na nitrate such as "straight NG Dynamites" (22.6-59.3 wt % Na nitrate); "high density ammonium Dynamite" (15.2-57.3 wt % Na nitrate); "straight gelatin" (38.9-60.3 wt % Na nitrate); and "ammonia gelatin" (33.5-54.9 wt % Na nitrate)] 4) S.C. Dollman et al, "Parameters Affecting Performance Characteristics of Cast Flare Systems", PATR **3839** (1969) (Limited Distribution) 5) B. Jackson, Jr et al, "Substitution of Aluminum for Magnesium as a Fuel in Flares", PATR **4704** (1975) [The authors report successful development of a flare compn for the US M49A1 trip flare which substitutes cheaper Al for the Mg of the standard compn. The developed compn contains 35% six micron atomized Al powder, 53% Na nitrate, 7% seven-micron W powder, and 5% Laminac 4116 poly-

ester resin (qv). Since the Al system exhibited gassing and self-heating when exposed to moisture, the authors recommend careful exclusion of moisture during processing. The developed replacement compn successfully survived long-term storage stability testing because of such careful processing] 6) N. Borodin et al, "Blasting Explosive for High Insertion Temperatures", EGerP 110844 (1976) & CA **84**, 182213 (1976) [The inventors claim that mixts contg Na nitrate 50-70, TNT 46.3-26.3 and cellulose 0.7% with 3% w added are safe for placement in blast sites at temps up to 100°]

Sodium Nitride. See in Vol 8, N102-L

Sodium Nitrite. See in Vol 8, N108-R

Sodium Oxalate. See in Vol 8, O31-L & R

Sodium Oxide. See in Vol 8, O51-L & R

Sodium Perchlorate. See in Vol 8, P167-R to P168-R

Sodium Peroxide. See in Vol 8, P191-R to P192-R

Sodium Picramate. See in Vol 1, A242-R to A243-L

Sodium Picrate. See in Vol 8, P283-L and the following *Addnl Refs*: 1) Anon, "Physical Testing of Explosives From the Explosives Research Laboratory, Bruceton, Pennsylvania", a reprint of pp 14 to 19 of OSRD **5746** (no date-before 1958) [Table V of the report lists the power of Na Picrate as 78 (TNT=100)] 2) H.Z. Baumbach, "Volumetric Analysis of Sodium Picrate", EATR **4390** (1970) (Limited Distribution)

Sodium Salts of Organic Compounds. See under the appropriate organic Na salt entries in all vols

Sodium Silicates. See in this Vol under "Silicates"

Sodium Sulfide (Sodium monosulfide and Sodium sulferet). Na_2S , mw 78.05; white deliq crystals, extremely hygroscopic, dissolves on exposure to air; mp 920° , 1180° (in vacuo) (separate values); d 1.856g/cc at $14/4^\circ$. Sol in w; sl sol in ethanol; insol in eth. CA Registry No [1313-82-2]. Prepn from the elements in liq ammonia, dehydration of the nonahydrate, or by heating Na acid sulfate with NaCl and coal above 950° , extraction with w and crystn. Explds on percussion or on rapid heating. Finely divided Na sulfide forms expl mixts in air

Strong irritant to skin and tissue. Reaction with air and moisture produces toxic and flammable H_2S vapors (Ref 3)

Refs: 1) Gmelin, System No 21 (1966), 1049 ff
2) Anon, "Combustible Solids, Dusts and Explosives", Vol 3, NFPA, Boston (1974), 252
3) Sax (1968), 1114 4) Merck (1976), 1121 (No 8450) 5) CondChemDict (1977), 801
6) ChemRubHdbk (1978), B-163

Sodium Tetraborate. See in Vol 2, B247-L to B248-L under "Borates" and "Borax"

Sodium Tetrachromate. See in Vol 3, C289-L

Sodium Trichromate. See in Vol 3, C288-R

SOFAR (Sound Fixing And Ranging) Bomb.

A device, originally patented by the US Navy, suitable for search and rescue operations at sea. A bomb, when dropped by a disabled vessel or aircraft, sinks into the ocean to a predetermined depth, where the hydrostatic pressure causes it to expld. This provides an underwater sound signal which can be picked up at distances up to 3000 miles away, enabling triangulation to the site of the expln (Refs 1 & 2). A modification of this concept (Ref 3) resulted in the design of a

SOFAR bomb designed to be ejected from a missile near the end of its trajectory as a means of locating the point of impact (in w only) of the missile nose cone

Refs: 1) Anon, Ordn 32, No 165 (1947), 146
2) Ibid 36, No 192 (1952), 968 3) W.H. Billig, TechMemo DW-361, AmmoGroup, Pic-Arsn (Sept 1961)

Sofranex A (Fr). A plastic mining expl, placed on the market in 1948 by the Société Française des Explosifs, consists of AN 48, NG 40, colloid cotton 2, Al powder 8, and liq DNT 2%. This compn has good w resistance, and has a CUP (see Vol 1, p IX) value of 144% (PA=100%). See also under "French Commercial Explosives of Nonpermissible Type" in Vol 3, C438-R

Refs: 1) L. Médard, "Progrès Récents et Tendances Actuelles dans les Explosifs de Mine en France", MP 32, 217-18 (1950) 2) Anon, "Handbook of Foreign Explosives", FSTC 381-5042, USArmyForSci&TechCenter (1965), 234

Solenoid Chronograph. See under "Chronographs" in Vol 3, C304-R to C319-L

Solenite. See in Vol 7, I177-R

Solfite. See under "Italian Explosives and Related Items" in Vol 7, I177-R

Solid Propellants. See under "Propellants, Solid" in Vol 8, P402-L to P473-L

Solothurn Ammunition. Ger pre-WWII 20mm armor piercing anti-tank ammo. The round consisted of an expl and incendiary loaded shell with a superquick, self-destroying fuze, and a steel cartridge case with a percussion primer
Refs: 1) J.A. Solomon, "Examination of 20MM Solothurn Ammunition", PATR 752 (1936)
2) W.H. Ewart, "Examination of 20MM Solothurn Ammunition", PATR 1053 (1940)

Table 1
Qualitative Solubilities of Pure Explosives
Expressed in Terms of Weight of Substance Dissolved at Room Temperature per 100ml of Solvent

i = insoluble (less than 0.1g)

sl = slightly soluble (0.1 to 5g)

s = soluble (over 5g)

Solvent	BTF	DATB	DIPAM	DNPA	EDNP	FEFO	HMX	HNAB	HNS	NC	NG	NM	NQ	PETN	RDX	TACOT	TATB	Tetryl	TNM	TNT
Acetone	s	i	s	s	s	s	sl	s	sl	s	s	—	i	s	s	—	i	s	—	s
Benzene	s	i	—	—	—	—	—	—	—	—	s	—	i	sl	i	—	i	s	s	s
CS ₂	—	i	—	—	—	—	i	—	—	—	sl	—	i	i	i	—	i	i	—	sl
CCl ₄	i	i	—	—	s	i	i	sl	—	i	sl	—	i	i	i	—	i	i	—	sl
Chloroform	—	—	sl	—	s	s	i	sl	—	i	s	—	i	i	i	i	i	sl	—	s
DMFA	s	s	s	—	s	s	sl	—	s	—	—	s	—	s	s	sl	i	—	—	s
DMSO	s	s	s	—	s	s	s	—	—	—	—	s	—	s	s	sl	i	—	—	—
Ethanol	s	i	—	—	s	s	—	—	—	s	s	s	sl	i	sl	i	i	sl	s	sl
Ethyl acetate	s	—	—	—	s	s	—	sl	—	—	s	—	i	s	i	—	i	s	—	s
Ethyl ether	s	—	—	—	s	s	i	—	—	i	s	s	i	sl	i	—	i	sl	s	sl
Nitric acid	—	—	s	—	—	—	—	—	—	—	s	—	sl	—	—	sl	—	s	—	s
Sulfuric acid	—	—	—	—	—	—	—	—	—	—	s	—	s	—	—	—	sl	—	—	s
Pyridine	s	—	—	—	s	s	sl	—	—	—	s	—	—	s	sl	sl	—	—	—	s
Water	i	i	—	—	i	i	i	—	—	i	sl	s	i	i	i	i	i	i	sl	i

3) F.G. Haverlak, "Examination of Unfired Explosive-Incendiary Shell; Complete Rounds of German 20MM Solothurn Ammunition (FMAM-518)", PATR 1478 (1944)

Solubility of Explosives. See under specific subjects in Encycl, ie, Pb Azide, Vol 1, A545-L; Nitrocelluloses, Vol 2, C101-L ff; RDX, Vol 3, C616; PETN, Vol 8, P89-R to P91-R; Amm Picrate, Vol 8, P277-R; Picric Acid, Vol 8, P287; etc

Of general interest are tables of the qualitative solubilities of pure expls (Table 1) and additives and binders commonly used in expl formulations (Table 2), taken from a compilation by Dobratz (Ref 1)

Sitzmann and Foti (Ref 2) detd the approx solubilities of representative expls (RDX, HMX, HNS, DATB, etc) in various solvents in a search for a general solvent for expls. This work was occasioned by the use in recent years of new

high melting expls (such as HNS; see Vol 5, D1456-R) which often cannot be removed and/or recovered from expl devices by conventional methods such as steaming, high-pressure w jetting, and machining. A possible alternative for removal of these expls would be by chemical dissolution

The following tables 3, 4, 5 and 6 (from Ref 2) detail the approx solubility (after 5 minutes of stirring at temps ranging from 25° to 95°) of RDX, HMX, HNS and DATB per 100g of candidate solvents:

Table 7 lists the approx solubility of some inorganic components of expl formulations as well as typical expls in dimethylformamide, and Table 8 compares approx solubilities after 5 and 30 mins of stirring at 25° (from Ref 2):

It should be emphasized that the solubility results given in Tables 3 thru 8 do **not** represent true equilibrium solubilities, but are sufficiently accurate to be of practical value. From this study, considering all the factors in the choice of

Table 2
Qualitative Solubilities of Additives and Binders
Expressed in Terms of Weight of Substance Dissolved at Room Temperature per 100ml of Solvent

i = insoluble (less than 0.1g)

sl = slightly soluble (0.1 to 5g)

s = soluble (over 5g)

Solvent	BDNPA BDNPF	Cab-O-Sil	DOP	Estane 5702-F1	Exon 461	Kel-F	Polystyrene	Sylgard 182	TEF	Viton A
Acetone	—	—	—	s	—	s	—	—	—	s
Benzene	s	—	—	—	—	—	s	—	s	—
Dichloroethane	—	—	—	s	—	—	—	—	—	—
DMFA	—	—	—	s	—	—	—	—	—	—
DMSO	—	—	—	s	—	—	—	—	—	—
Gasoline	—	—	s	—	s	—	—	—	—	—
Glycerine	—	—	i	—	—	—	—	—	—	—
MEK	—	—	—	s	s	s	—	—	s	s
MIBK	—	—	—	s	—	s	—	—	s	s
THF	—	—	—	s	—	s	—	—	—	s
Toluene	s	—	—	—	s	i	s	—	s	—
Water	i	—	i	—	—	—	—	—	i	—
Xylene	—	—	—	—	s	—	—	—	s	—

Table 3
Solubility of RDX^a

Solvent	25°C	40°C	60°C	80°C	98°C
Dimethylsulfoxide	41	51	66	87	113
Dimethylformamide	37	45	58	76	96
N-Methylpyrrolidone	40	47	58	72	84
Butyrolactone	14	—	28	41	61
Acetone	8.2	12	17 ^b	—	—

^a Grams of RDX per 100g of solvent after 5 mins of stirring

^b At the boiling point

Table 4
Solubility of HMX^a

Solvent	25°C	60°C	98°C
Dimethylsulfoxide	57	68	89
Dimethylformamide	Solvate ^b	Solvate	Solvate
N-Methylpyrrolidone	Solvate	Solvate	Solvate
Butyrolactone	12	20	35
Acetone	2.8	4.2 ^c	—
Butyrolactone (73%), dimethylsulfoxide (27%)	26	33	49

^a Grams of HMX per 100g of solvent after 5 mins of stirring

^b Shortly after the HMX dissolves, precipitation of the solvate crystals occurs

^c At the boiling point

Table 5
Solubility of HNS^a

Solvent	25°C	60°C	80°C	98°C
Dimethylsulfoxide	1.4	2.4	3.6	9.1
Dimethylformamide	1.5	3.2	4.6	7.0
N-Methylpyrrolidone	2.4	4.6	6.4	8.4
Butyrolactone	0.4	—	—	3.2
Acetone	<0.1	0.4 ^b	—	—

^a Grams of HNS per 100g of solvent after 5 mins of stirring

^b At the boiling point

Table 6
Solubility of DATB^a

Solvent	25°C	60°C	80°C	98°C
Dimethylsulfoxide	2.2	8.8	14	19
Dimethylformamide	2.5	5.1	9.7	14
N-Methylpyrrolidone	4.5	7.8	11	17
Butyrolactone	0.8	—	—	4.8
Acetone	0.4	1.4 ^b	—	—

^a Grams of DATB per 100g of solvent after 5 mins of stirring

^b At the boiling point

Table 7
Solubilities of Explosives in Dimethylformamide^a

Explosive	0°C	25°C	60°C	80°C	98°C
RDX	27	37	58	76	96
TNT	90	142	—	—	—
Tetryl ^b	91	114	—	—	—
HNS	—	1.5	3.2	4.6	7.0
DATB	—	2.5	5.1	9.7	14
Amm picrate	84	90	—	—	—
Nitroguanidine	—	15	20	—	28
Amm nitrate	47	54	—	—	—
Amm perchlorate	46	47	—	—	—

^a Grams of explosive per 100g of DMF

^b Tetryl = 2,4,6-trinitrophenylmethylnitramine

Table 8
Comparison of Solubilities^a
After 5 and 30 Mins of Stirring at 25°C

Explosive	Solvent	5 Mins	30 Mins
DATB	Dimethylsulfoxide	2.2	2.3
HNS	Dimethylsulfoxide	1.4	1.4
RDX	Dimethylsulfoxide	41	41
RDX	Dimethylformamide	37	36
HMX	Dimethylsulfoxide	57	58
HMX	Butyrolactone	12	13

^a Grams of explosive per 100g of solvent

a solvent (solubility values, physical props, cost, availability, convenience, and toxicity), dimethylformamide appears to be the best choice as a general solvent for expls. Dimethylsulfoxide, butyrolactone or butyrolactone-dimethylsulfoxide mixts can be used for HMX

Refs: 1) B.M. Dobratz, "Properties of Chemical Explosives and Explosive Simulants", **UCRL-51319, Rev 1**, Lawrence Livermore Laboratory, Livermore, Calif (1974), p 5-7 2) M.E. Sitzmann & S.C. Foti, "Solubilities of Explosives—dimethylformamide as General Solvent for Explosives", *JChem&EngData* **20**, No 1 (1975), 53–55

Solventless Powder. See under "Cannon Powder (Propellants)" in Vol 2, C33-R, and "Propellants, Solid" in Vol 8, P405-R to P406-L and P420-R

Solvent Naphtha, Nitrated. See Vol 8, N4-L

Solvent Powder. See under "Single-Base and Double-Base Cannon Propellants" in Vol 2, C31-R to C33-R, and "Production Methods of Representative Propellants" in Vol 8, P420-L

Solvent Removal by Evaporation and Drying. See under "Drying" in Vol 5, D1560-R to D1565-L

Sonar. Acronym for **SO**und **NA**avigation and **R**anging. A communication and position-finding device used in underwater navigation, target detection, and weapon control. It is based on the use of acoustic energy in a manner similar to the use of electromagnetic energy in *Radar* (qv). Both techniques depend on the emission of energy beams, which are "bounced off" reflecting objects to detect their presence (by the act of reflection) and to measure their range (by timing the return of the beam to the receiving app). In sonar as in radar, the direction of the object is detd by comparing the intensity of the returning beam as the source of the beam is traversed and elevated, the returning beam being most powerful when the receiver is

pointing directly at the reflecting object. But sonar operates in a far less favorable medium than radar. Sound travels in w at variable speeds around a median of 1500m/sec; significant errors can therefore arise from post-ranging movements of the object observed. Further, the speed of sound in w varies with the salinity, the temp and the depth, thus affecting the stability of the time/distance conversion. These factors severely limit the accuracy of sonar ranging. The other limiting factor in sonar operation is the long wavelength of acoustic energy (at least 10cm). This sets a max ceiling on the resolution (min distance between separately detectable points) of sonar devices. Sonar techniques are still the most useful in anti-submarine warfare, since the other means available (optical detection and radio techniques) are even less reliable and severely limited in range

There are two basic forms of sonar, active and passive. Passive sonar depends on the sound produced by the object observed and a simple, direct listening can be employed, though there are usually a transducer (to convert the acoustic energy into electromagnetic energy), an amplifier and a directional device. The advantage of the passive mode in sonar observation is the fact that its operation cannot be detected

Active sonar consists of a transducer, which provides the acoustic energy beam, a transmitting antenna and a receiver-transducer-amplifier which processes the returning beam. As in many types of radar, the sound beam is sent in pulses, so that range can be detd by timing the returning beam, identified by its place in the series of pulses

Sonar can also be used for underwater communication, including direct voice communication, where the human voice is transmitted as modulated ultrasonic energy by an active sonar device

In navigation and target detection, a scanning active sonar can be used to provide a realistic visual picture of sound-reflecting objects around the source. The scanning beam is rotated, and the reflected beams show the position of objects in a given plane as echo "blips". Another display is required to show the depth/altitude of the object observed

Sonar is also used to control weapons. Acoustic homing torpedoes are guided by a sonar device which "locks on" the target, a program-

mer which converts target position data into directional instructions, and a servo-mechanism which actuates the torpedo's control surfaces. Such torpedoes are launched from ordinary deck tubes and aircraft dispensers, but they are also used as the terminal stage of anti-submarine missiles such as *Asroc*, *Ikara*, and *Subroc*

Variable depth sonar is found on most modern anti-submarine warfare vessels. As the name indicates, the device can be suspended below the hull. Fixed-bow sonar is used for long-range detection/location, and one such device has detected a submarine at ranges in excess of 2000 miles

Dipping sonar devices equip manned anti-submarine helicopters and fixed-wing aircraft; the aircraft flies low and suspends a sonar device at the end of a wire-link which is held just below the surface of the w. The sonar technique is also used in *sonabuoy*s, which use active or passive sonar to detect and locate submarines. *Sonabuoy*s provide anti-submarine warfare data to aircraft which cannot dip sonar devices while hovering overhead, the data being transmitted by coded radio signals

Refs: 1) E. Luttwak, "A Dictionary of Modern War", Harper & Row, NY (1971), 177-78
2) R.T. Pretty, Ed, "Jane's Weapon Systems-1977", Franklin Watts, NY (1976), 671-97 (Sonar and underwater detection equipment--Australia, Canada, France, Italy, Netherlands, UK, & USA)

Sonic Booms' Threat to Explosive Facilities.

The potential consequences of sonic booms are direct initiation of expls, unfavorable instrument reaction, window breakage, startle reaction in personnel, and bric-a-brac movement. Of these, the latter two fall within the range of the ordinary reaction to sonic booms; window breakage would occur with heavy to intense sonic booms

Refs: 1) R.W. Van Dolah, *AmSocSafetyEngJ* **13**, No 9 (1969), 12-14 2) G. Cohn, Ed, *Expls & Pyrots* **2**, No 3 (1969), 4

Son Nitré (Fr). Nitrated bran. See under "Bran" in Vol 2, B260-R

Sonite (Brit). A mixt of guncotton and sol NC with the addition of 1% mineral jelly. It was manufd in tubular form and used in smokeless blank cartridges

Ref: Anon, "Treatise on Ammunition", War Office, HMSO (1915), 39

Sonobuoy. See as *sonabuoy* under "Sonar" in this Vol

Sophonius Incendiary Composition. Consisted of 3p concd sulfuric acid with 2p K permanganate
Ref: Daniel (1902), 154

Sorbitol and Derivatives

Sorbitol. See in Vol 6, G81-R to G82-L under "D-Glucitol (Sorbitol) and Derivatives" and the following *Addnl Refs:* 1) Beil **1**, (2839)
2) Merck (1976), 1126 (No 8497) (The CA Registry No for sorbitol is shown as [50-70-4]. An addnl comml prepn is reported; ie, the electrolytic reduction of glucose) 3) M. Maciejewski et al, "WATEX Slurry Explosive Material", *PrzegłGorn(Pol)* **1977**, 33 (6), 264-65 & CA **88**, 39532 (1978) [The authors describe (in Polish) the expl properties of slurry expls consisting of Al, sorbitol (as a fuel), Amm nitrate, w and a w sol thickening agent. The expls were used experimentally to mine Cu and blast limestone in a quarry]

Sorbitol Nitrate. See in Vol 6, G82-L under "D-Glucitol (Sorbitol) Nitrate" and these *Addnl Refs:* 1) A. Foulon, *SS* **27**, 191-93 (1932) & CA **26**, 5209 (1932); also, *Ibid*, *MAF* **14**, 461 (1935) & CA, not found. [The author reports a Nobel P (GerP 513397) of an expl oil prepd by nitration of a mixt consisting of 50% sorbitol, 25% glycerin and 25% glycol which is considered superior to straight NG] 2) J.A. Monick, "Alcohols-Their Chemistry, Properties and Manufacture", Reinhold, NY (1968), 415. [The author cites the use of sorbitol in expls by a general statement, "... The nitration of a glycerin-ethylene glycol solution of sorbitol yields a low-freezing, liquid, high-explosive

mixture which has value for dynamite formulas . . .”]

Sorbitol Pentanitrate (or Penta-o-nitro-D-glucitol). $C_6H_9N_5O_{16}$; mw 407.20; N 17.20%; OB to CO_2 -1.96%; oily liq. Sol in ethanol. Prepn is by adding dropwise a mixt of 5g sorbitol in 25g of concd nitric acid (d 1.52g/cc) at -10° to 50g of concd sulfuric acid at -10 to -70° . The yield is 7.5g of a mixt which consists mostly of the Pentanitrate mixed with some Hexanitrate. This oily mixt which is reported erroneously as Sorbitol Hexanitrate by Davis (Ref 2) and correctly as a mixt of Penta and Hexa nitrates by Urbański (Ref 4) is used as an additive to NG in low-freezing Dynamites

Refs: 1) Beil 1, (2840) 2) Davis (1943), 238 3) T. Urbański & S. Kwiatkowska, RocznikiChem 25, 312-14 (1951) & CA 48, 5093 (1954) 4) Urbański 2 (1965), 172

Sorbitol Hexanitrate. See in Vol 6, G82-L under “D-Glucitol (Sorbitol) Hexanitrate” and the following *Addnl Refs*: 1) Beil 1, (2849) 2) A. Tettamanzi & N. Arnaldi, “Preparation of Hexanitrosorbitol and Its Explosive Properties”, AttiRaccadSciTorinoClasseSciFisMatNat 77, 278-81 (1942); Ibid, ChemZtr 1, 1848-49 (1943) & CA 38, 3841 (1944) [The authors report their prepn of Hexanitrosorbitol thusly: the nitration is performed using sorbitol of high purity by treatment with 5p of fuming nitric acid at a temp below 0° with gradual addn of concd sulfuric acid at a temp of not more than -15° (using a CO_2 -toluene bath). The prod is then treated with ice w, w-washed and finally amm carbonate-washed. Crystn is from ethanol. The yield is 97% of theory. The authors subjected the Hexanitrosorbitol to various tests, the results of which are presented in Table 1 in comparison with NG

Table 1
Properties of Hexanitrosorbitol

Properties	Hexanitrosorbitol	NG
Density, (g/cc)	1.58	1.60
Freezing point, ($^\circ C$)	55.5	13
Heat of combustion, (kcal/kg)	1465	1630
Heat of formation, (kcal/mol)	135	83
Heat of explosion, (kcal/kg)	1500	1560
Temp of flame of explosion, ($^\circ C$)	4700	5100
Vol of gas in 1 kg at 0° and 760mm	701	715
Velocity of detonation, (m/sec)	7230	7650
Specific pressure, (f = atm/kg)	13200	14600
Brisance ($B = f \times d \times v \times 10^{-6}$)	150	189
Impact sensitivity in cm (2kg weight)	7	5
Friction sensitivity	v sens	v sens
Trauzl test (expansion in cc)	480	455
Abel test at 80° , (minutes)	10	18
German test at 120° , (discoloration of methyl violet paper after)	15 min	17 min
Bergmann-Junk test at 100° , (cc of NO per 1 g sample in 2 hours)	1.88	1.40
Taliani test at 100° , (Pressure of 300mm developed after)	3h 50'	4h 30'

These tests showed that Hexanitrosorbitol is about as sensitive to impact and friction as NG and that it is less stable to heat. Its expl props, with the exception of power (as detd by the Trauzl test) are lower than those of NG. Its low mp does not permit its use for loading projectiles directly but it is possible, the authors conclude, that it can be used in mixts with other expls. The authors further report that attempts to use it, in admixt with NG, as a gelatinizer for NC, did not give satisfactory results because proplnt prepd in such a manner became brittle on storage and was found to be greatly inferior to ordinary Ballistite] 3) J. Sallé, "Pharmacology of Nitrated Sorbitol", *ArchInternPharmacodynamie* **98**, 355-61 (1954) & *CA* **49**, 7115 (1955) [Nitrated sorbitol has a vasodilator effect in dogs similar to that of Hexanitromannitol, only sl more toxic]

Soude, Dynamite à la (Fr). Dynamites contg Na nitrate, such as, *No 2 Arles*: Na nitrate 52, NG 35 & cellulose 13%; *No 3 Arles*: Na nitrate 66, NG 22 & woodflour 12%; *No 2 Cugny*: Na nitrate 43, NG 40 & cellulose 17%; and *No 3 Paulilles*: Na nitrate 66, NG 22 & charcoal 12%. See also under "Dynamite and Substitutes" in Vol 5, D1584 ff, and "French Dynamites" in Vol 6, F191-R to F194-R
Ref: Daniel (1902), 723

Sound as a Weapon. During WWII, the Ger Ministry of Armaments and War Production established a research center near Lofer, Austria, in which Dr. R. Wallauschek attempted to use sound as a weapon. His best design consisted of a parabolic reflector, 3.2m in diam, having a short tube which was the combustion chamber or sound generator, extending to the rear from the vertex of the parabola. The chamber was fed at the rear by two coaxial nozzles, the outer nozzle emitting methane, and the central nozzle oxygen. The length of the chamber was one-quarter the wavelength of the sound in air. Upon initiation, the first shock wave was reflected back from the open end of the chamber and initiated a second expln. The frequency was from 800 to 1500 impulses per sec

The main lobe of the sound intensity pattern

had a 65° angle of opening, and at a distance of 60m on the axis a pressure of 1000 microbars had been measured. No physiological expts had been conducted, but it was estimated that at such a pressure it would take from 30-40 secs to kill an individual. At greater ranges, perhaps up to 300m, the effect, though not lethal, would be very painful and would probably disable an individual for an appreciable length of time. Vision would be affected, and low-level exposures would cause point sources of light to appear as lines

However, the general opinion was that the military value of such a device was limited, to say the least, owing chiefly to the lack of range
Ref: L.E. Simon, "German Research in World War II", J. Wiley & Sons, NY (1947), 181-83

Sound or Noise Suppressors.

Background. The report or noise of a firing gun is numbered among the various objectionable phenomena that develop at the muzzle. Noise is closely associated with flash and muzzle blast inasmuch as attempts to attenuate any of the three will unquestionably have some influence on the other two. On the other hand, if no controlling measures are taken, secondary flash may prolong the duration of report and muzzle blast but not necessarily increase their intensity. And, since muzzle gas pressures are related to all three, noise and blast intensity may be assumed to influence flash

Noise produced by weapon firing can be hazardous to hearing, cause communication interference and aid the enemy in detection. A blast deflector offers relief to the crew by diverting the harmful pressure waves away from the crew area but without reducing the intensity to the extent where it becomes undetectable. A flash suppressor, however, can incorporate features that reduce the intensity of the noise. If this type muzzle device can be developed to the point where both flash and noise can be reduced to acceptable limits, two knotty problems become solved simultaneously. A large amount of effort has been expended on flash suppressors; considerably less on noise inhibitors. A measure of success has been achieved in the suppression of noise thru exptn. No general design procedures, either theoretical or empiri-

cal, have been developed for a noise suppressor, primarily because no appreciable effort was ever assigned to develop this type of muzzle device. A measure of success has been achieved in the suppression of noise but usually as a by-product of the development of another type of muzzle device, such as a flash suppressor

General Requirements. Noise is an inherent characteristic of a gun and is usually associated with three main producers: the projectile, the muzzle, and the gun components other than the muzzle. The noises produced by the gun components are mostly mechanical such as the sounds of moving parts, impact, and vibration. The projectile noises are mainly those caused by air turbulence following the projectile and the supersonic shock wave or ballistic crack generated by the projectile nose. Muzzle noises are produced by the air pressure build-up in the tube ahead of the projectile and by the propellant gases issuing from the muzzle after the projectile passage

The most intense noise of a firing gun is caused by the rapidly decaying shock wave that continues to travel at sonic velocity as an impulse wave or sound wave. A crude but effective experiment was conducted by firing a 7.62mm rifle thru a metal container 10 inches long by 8 inches diam. One end was attached to, and supported by, the muzzle. The other end had a bullet exit hole of 7/16-inch diam in its center. When the gun was fired, the sound level of the report was drastically reduced. This sound level was not measured but seemed equivalent to that of a cal .22 rimfire cartridge. The sound reduction may be rationalized by computing the gas pressure in the can. Based on Corner's theory for space mean pressure and the characteristics of NATO 7.62mm round, adiabatic expansion will yield a computed gas pressure of 31.5psia for one round. The resulting critical gas pressure ratio of 0.47 indicates the gas exit velocity to be subsonic; therefore, the sound heard is that of the projectile

Four operations determine the effectiveness of a noise suppressor: 1) It should cool the muzzle gases to the temp that would quench the burning gases and later prevent reignition; 2) It should mix muzzle gases with air gradually to prevent atm oxygen from supporting combustion; 3) It should decelerate the muzzle gases to

prevent shock-front formation; and 4) It should retain the gases until they become relatively cool thru expansion thus preventing shock-front temp increases

Operations 1, 2 and 4 prevent secondary flash and thus the noise associated with it. Operation 3 has inherent noise producing capabilities. To be successful, any one or a combination of the four operations must be incorporated in a suppressor. Cooling will occur if the gas flow is checked long enough at a heat sink for heat to transfer by convection and conduction, or by adiabatic expansion in a changing area flow passage. Gradual mixing can be arranged by progressive venting downstream. Deceleration

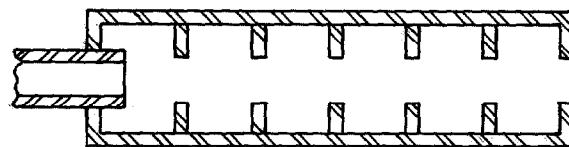

(A) Conventional Silencer

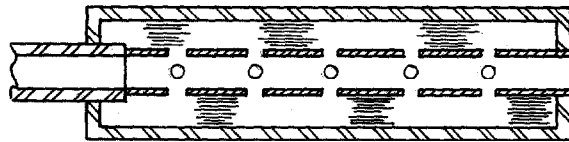

(B) Absorbent Material



(C) Two Stage Divergent

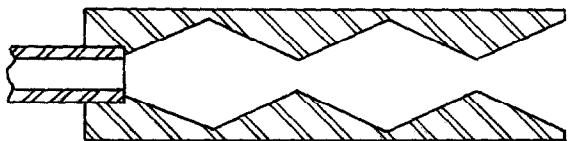

(D) Three Stage Divergent

Fig 1. Sound Suppressors (Schematics)

and retention are to be had by changing the cross-sectional area of the directed flow passage *Sound Suppressor Experiments*. No specific procedures or data now exist for designing a sound suppressor for any given gun but work is currently being done in this area. However, expts have been made to determine the feasibility of such muzzle devices. One type was based on the practice of bleeding off the gases before normal acceleration of the projectile is complete. This method was effective to a large degree, but at the expense of a greatly reduced muzzle velocity that generally cannot be tolerated. Other tests were performed with two conventional silencer types and two divergent-convergent flow passage types. These four are shown schematically in Fig 1. Type (A) is the conventional baffle type. Type (B) has vents that permit access to a chamber filled with absorbent material, such as glass wool or metal screening. Type (C) has two diverging passageways connected by a converging one, whereas Type (D) adds another converging-diverging section. Types (C) and (D) are effective flash suppressors

These models were tested by firing cal .45 M1911 ammo. The sound was measured at 10m to the right of the muzzle. The measured intensities are shown below to be compared with the 141 decibels having no suppressor attached:

Suppressor	(A)	(B)	(C)	(D)
Decibels	124	119	136	132

The above data indicate that the divergent-convergent passage does suppress sound but still not as effectively as the baffle or absorbent material type silencers. However, when based on energy levels, Type (D), in attenuating the sound from 141 dB to 132 dB, reduces the energy level by 87 percent. Although there is a paucity of technical information with respect to designing sound suppressors, the known characteristics indicate that this muzzle device is feasible

Refs: 1) H.P. Maxim, "Silencer", USP 1736319 (1929) 2) W.P. Mason, "Sound Muffler", USP 1874326 (1932) 3) R.B. Bourne, "Sound Attenuating Device", USP 2043731 (1936) 4) F.E. Deremer, "Silencer Construction", USP 2241768 (1941) 5) B. Walker, "Silencer for Firearms", USP 2449571 (1948) 6) W.J. Jarrett, "Noise Reducer for Gun", USP 2868078 (1959) 7) Anon, *EngrgDesHndbk*, "Guns Series—Muzzle Devices", AMCP-251 (1968), 1-11 to 1-12 & 8-1 to 8-2 8) E.C. Ezell, "Small Arms of the World", 11th Ed, Stackpole (1977), 105-13

Sound Velocity Through Explosive. Longitudinal and transverse shear sound velocities were

Table 1
Sound Velocities Through Explosives

Explosive and Preparation	(Mg/m ³)	c_l (km/s)	c_s (km/s)	c_b (km/s)
Baratol (cast)	2.538	2.95	1.48	2.40
Comp B-3 (cast)	1.726	3.12	1.71	2.42
Cyclotol (cast)	1.752	3.12	1.69	2.43
DATB (pressed)	1.78	2.99	1.55	2.40
Octol (cast)	1.80	3.14	1.66	2.49
PBX-9010-02	1.78	2.72	1.47	2.13
PBX-9011-04	1.77	2.89	1.38	2.41
PBX-9404	1.83	2.90	1.57	2.26
PBX-9407	1.78	3.04	1.70	2.32
TATB (pressed)	1.87	1.98	1.16	1.46
Tetryl (pressed)	1.68	2.27	1.24	1.76
TNT (pressed)	1.61	2.48	1.34	1.94
TNT (pressed)	1.632	2.58	1.35	2.08
TNT (molten)	1.47	—	—	2.10

measured by Marsh of the Los Alamos Scientific Laboratory (Ref 2) for expls with large acoustic attenuation. The arrival time of signals traveling thru different thicknesses of stacked samples were measured and the sound velocities were detd by a differential technique, ie, by measuring the transit times of the signals thru the measured thicknesses of the samples

The bulk sound velocities, c_b , were detd from the expression for isotropic materials:

$$c_b = \sqrt{c_l^2 - \frac{4}{3} c_s^2}$$

where: c_l = longitudinal sound velocity
 c_s = shear sound velocity, and are compiled in Table 1

Refs: 1) J.E. Lindstrom, JApplPhys **37**, 4873-4880 (1966) 2) B.M. Dobratz, Ed, "Properties of Chemical Explosives and Explosive Simulants", UCRL-51319, Rev 1, Lawrence Livermore Laboratory, Livermore, Calif (1974), 7-21 to 7-23

SP₁, SP₂, SP₃ (Poudres). Fr BlkPdrs used in large cal cannon (up to 270mm) prior to the invention of smokeless proplnts. SP₁ was granulated so as to contain 340 to 370 grains of powder per kg; SP₂ 100 to 110; and SP₃, 10. Also see Vol 2, B172-L

Ref: Daniel (1902), 734

SP₂SD. Coton-poudre 2, sans dissolvant. Fr NC with a N content of about 11.7%, used in solventless smokeless proplnts

Ref: Daniel (1902), 734

Spalling. See under "Scabbing" in this Vol

Spanish Commercial Explosives. See under "Spanish Commercial Explosives of Nonpermissible Type" in Vol 3, C441-R to C442-L, and "Spanish Permissible Explosives" in Vol 3, C454-R to C455-L

Spanish Dynamites and Their Substitutes

Accdg to Sancho (Ref 1) and Vivas, Feigenspan & Ladreda (Ref 2), Spanish *Dinamitas* are divided into: 1) *Dinamitas de base inerte*, and 2) *Dinamitas de base activa*

To the first group belongs *Dinamita especial roja* which contains NG 71 & kieselguhr (guhr) 29%

To the second group belong *Dinamita especial negra*: NG 24, Na nitrate 62 & carbon 14%, and *Dinamita núm 3*: NG 22.50, Na nitrate 65.52 & carbon 11.98% (Ref 1, p 204 & Ref 2, p 398)

The so-called *Dinamitas gomas de Nobel* consisted of NG gelatinized by CC (Collodion Cotton), with no other ingredients. The following gomas were used in Spain: *Núm 1*: NG 90 & CC 10%; *Núm 2*: NG 91.6 & CC 8.4% and *Núm 3* (extrafuerte): NG 93 & CC 7% (Ref 2, p 392)

Dinamitas goma manufd by the Fábrica de Galdácano (Vizcaya) contain other ingredients beside NG & CC. Four formulations: *Dinamita goma núm 1, especial*; *Dinamita goma núm 2, especial*; *Dinamita goma núm 3, especial*, taken from Refs 1 & 2 are detailed in Vol 3 of the Encycl (Ref 3, C441-R & C442-L)

Two nonfreezing (or low-freezing) Dynamites are listed in Ref 2, p 396. They are: a) *Dinamita goma incongelable al dinitroglicol*: NG 66.4, NGc 16.6, CC 5.0, alkali nitrate 10.0 & sawdust 2.0%; and b) *Dinamita goma incongelable al dinitrotolueno*: NG 75, DNT 8, CC 5, alkali nitrate 10 & sawdust 2%

Spanish permissible expls are known as *Antigrisú*, *Grisúnaftalita* and *Grisutitas*, and are described in Ref 3, C454 & C455

Following is a complete list of Spanish Dynamites described in Ref 3, pp C441-C442 and C454-C455: Amonal, Amonita núm 5, Antigrisú (Explosivos), Astralita antigrisutosa, Cartuchos con corteza (Sheathed Cartridges), *Dinamitas de la Fábrica de Galdácano (Vizcaya)*, Donarita, Explosivo F.E., Explosivo núm 3, Explosivo de seguridad de la Fábrica de Galdácano, *Grisúnaftalita*, *Grisutitas capa*, *Grisutitas roca*, *Nitramita espanola de la Fábrica de Granada*, *Nitramita de la Fábrica de Galdácano*, *Nobelita antigrisú gelatinizada*, *Plomoplastita (Ploplastita)*, *Sabulitas espanoles*, *Sheathed Car-*

tridges (Cartuchos con corteza), Tolita and Triplastita

Not included in this list were: *Nobelita* described in Ref 2, p 399: NG 20.0, CC 1.6, Na nitrate 60.0, DNT 14.0, sawdust 4.3 & Na bicarbonate 0.1%; and *Gelatina explosiva de guerra*: NG 86.4, CC 9.6 & camphor 4.0% (Ref 2, p 393)

Written by B. T. FEDOROFF

Refs: 1) E.E. Sancho, "Química de los Explosivos", Agudo, Madrid (1941), 199-207
2) Vivas, Feigenspan & Ladreda, 2 (1946), 387-99
3) B.T. Fedoroff & O.E. Sheffield, "Encyclopedia of Explosive and Related Items", PATR 2700, Vol 3 (1966)

SPANISH EXPLOSIVES AND AMMUNITION (Explosivos y Municiones)

Historical. The manufacture of explosives, ammunition and weapons in Spain is of very old origin and has been of very high quality even after Spain lost its colonies and sources of some raw materials

A Black Powder (Gunpowder) Plant was constructed in the middle of the 14th century in Granada by the Moors (Moros), who at that time (since the 8th century) occupied most of the Iberian Peninsula where present Spain is located. Accdg to Sancho (Ref 1, p 254), the Moors used artillery in 1331 at the siege of Alicante in Southern Spain. Accdg to F. de Solas López (Ref 13, p 21), the weapon used in 1333 by Moors in Spain was the *Bombarda* (Bombard), a very heavy *Boca de fuego* (Fire-arm) made of iron bars by the method similar to that described in Vol 2 of the Encycl, B222. A much lighter weapon, the *Culebrina* was introduced at the end of the 15th century when a method of casting copper-tin alloys was developed. This was at about the time when, at the battle of Granada in 1492, the Moors were defeated by the Spanish Army under King Ferdinand and Queen Isabel. This ended the occupation by the Moors. When in 1494 Columbus discovered the New World and its gold, Spain became the richest country of the World. These riches enabled Spain to create a large Army and

Navy (Armada) and to organize a war industry

The *Culebrina* mentioned above was probably similar to the *Culverin*, described in Vol 3 of the Encycl, C573-L. The *Culebrina* was soon partly replaced by *Canon* (Cannon) which was of smaller caliber than the *Bombarda*. All of the above-mentioned weapons were smooth-bore (armas con ánima lisa), cylindrical in shape, closed at one end and muzzle-loading (armas de avancarga). Cannons were improved in the 17th century by Bribeauval of France and used in many countries, including Spain. The first rifled weapon (arma de ánima rayada) was introduced during the Crimean War (1855) and used by the Spanish in 1868 at Alcolea. The use of rifled bores was possible only in breech-loading weapons [armas con ánima de postecarga (o de retrocarga)]

Spain was a very powerful nation until she lost most of her great Navy (Invincible Armada) at the end of the 16th century during the rule of King Philip II. This disaster did not stop, however, the Spanish military industry and part of the production went abroad. Spanish small arms, especially pistols, were very popular before and during WWI, especially in Russia. Dr. B.T. Fedoroff had an "Astra" Pistol while serving in the Russian Navy during this period

At the present time Spain has a large, well equipped Army and its war industry is working for the NATO countries

The following compilation briefly describes, in alphabetical order, military expls and ammo manufd in Spain:

Aceite explosivo. One of the names for Nitroglycerin (Nitroglicerina)

Ácido nítrico. Nitric acid

Ácido picrico, Picrinita or Trinitrofenol. See "Picrinita"

Aire líquido y Oxilíquida. See Oxilíquida y Aire líquido

Algodón fulminante, Fulmicotón or Algodon pólvora. Guncotton. See "Nitrocelulosas"

Altos explosivos. High explosives, such as TNT, PETN, RDX, etc

Amatex. See under "Amatolos"

Amatolos (Amatols). Mixts of AN and TNT (Tol) in various proportions. A general description is given in Vol 1 of the Encycl, A158–A165. The 50/50 Amatol was used in Spain for the loading of projectiles, mines and depth charges. The mixt contg AN 80 and TNT 20% is also known as *Nitramita Espanola*. A mixt of Amatol with Al is called *Minol* (qv), and Amatol sensitized by a small amt of Hexanitrodiphenylamine is known as *Amatex* (qv) (Ref 9, pp 28–29)

Ammonium Nitrate. See "Nitrato amónico"

Ammonium Picrate. See "Picrato amónico"

Amonales (Ammonals). Originally mixts of AN (Ammonium Nitrate) with powdered Al, while later formulations included some fuels (such as powdered carbon) and HE's (such as TNT). A general description is given in Vol 1 of Encycl, A287 to A293. The compn for a Spanish Ammonal listed in the table on p A291 was: AN 84.5, K nitrate 1.5, Ba nitrate 0.5, Al (powder) 5.5, and charcoal 8.0%. Another compn, known as *Amonalo núm 1*, was developed in 1933 by Prof A. Blanco and used during the Spanish Civil War (1936–39) for filling aerial bombs. Its constituents were AN 92.4, Al 1.0 and powdered carbon 6.6%. Its properties were claimed to be the equal of 75% Dynamite

Some similar compns were known as *Amonal P*, *Amonal T*, *Anagon*, *Nitramita de guerra*, *Eco*, *Sabulita*, etc (Ref 9, pp 28–29 & Ref 17, p 430)

Compositions of non-permissible (de no seguridad) Ammonals are given in Vol 3 of the Encycl, C441-R (see also Ref 6, Vol 2, p 372)

Amonitas (Ammonites). Accdg to Jiménez (Ref 9, p 29) they are mixts contg from 50 to 100% AN, other nitrated products and a small proportion of other substances such as NG, sawdust and dichromates. Some expls of this type are called *Explosivos Favier*, *Astralita*, *Roburita*, *Donarita*, and *Perdita*. Such mixts are somewhat more sensitive to shock and frictions, and have a lower rate of detonation than other AN expls. Their hygroscopicity and relative instability in prolonged storage are the principal disadvantages. They are used in mining operations and as main charges in some projectiles

The compn of *Amonita núm 5*, a nonpermissible (de no seguridad) expl, is AN 80, TNT 14, NG 2, sawdust 2 and ferrosilicon 2% (Vol 3 of Encycl, C441-R & Ref 6, Vol 2, p 377)

Anagon. An Ammonal-type expl which contains AN 70, Al/Zn alloy 20 and charcoal 10% (See Vol 1 of Encycl, table on A239)

Antigrisú Explosivos (Permissible Explosives). Also known as *Explosivos de seguridad*. Compns of *Antigrisú números 1, 2 y 3*, given in Vol 3 of Encycl, C554-R are: *Núm 1* – AN 80.6, DNN (Dinitronaphthalene) 6.4 and Amm chloride 13.0%; *Núm 2* – AN 80.9, DNN 11.7 and Amm chloride 7.4%; and *Núm 3* – AN 82.0, TNN 5.0 and Amm chloride 13.0% (See also Ref 6, Vol 2, p 379)

Armas de tiro curvo y vertical. Curved and vertical trajectory weapons (See Ref 13, p 329)

Armas de tiro tenso (tendido). Flat trajectory weapons (See Ref 13, p 179)

Artilleriá (Artillery). A pamphlet of the Ministerio del Ejército (Ref 18) describes the Reglamentos de Artilleriá Tomos I, I-A, I-D, III, Anexo IV (Projectures), Anexo V (Artilleriá de Montana), and Anexo VI (Artilleriá Pesad). Also described are Artilleriá Antiaérea, de Costa, and de Campana (See also Ref 13, pp 15 & 17)

Astralita (Astralit). Accdg to Jiménez (Ref 9, p 29) it is an Amonit-type expl, but no compn is given. Two Ger and one Ital Astralits are detailed in Vol 1 of Encycl, A497-R & A498-L. In Ref 6, Vol 2, p 380, the following formulation is given for *Astralita antigrisutosa* (permissible Astralit): AN 57, NG 12, charcoal 2, coal dust 2 & Na chloride 27%

Azido de plomo, Nitruro de plomo, Plumbazida. Lead Azide, a detailed description of which is given in Vol 1 of Encycl, A545 to A555

The props of Spanish made Pb Azide is given by Jiménez (Ref 9, p 139) as follows: loading d, 4.6g/cc; brisance by Kast formula, 107 (TNT 86); heat of expln, 260cal/g; temp developed on expln, 3450°; vel of deton, 5300m/sec; vol of gases on expln at 0° & 760mm pressure, 310 l/kg (See also Ref 13, p 406)

Pb Azide is used alone or in mixts with other expls such as Pb Styphnate (see *Stifnato de plomo*) in primers and detonators

Baratols. HE compns of Ba nitrate and TNT in various proportions developed by the Brit during WWII, and in Vol 2 of Encycl, B18-L to B19-R

Baratols of compn Ba nitrate 10 to 70 and TNT 90 to 30% were used by the Spanish as bursting charges in shells and bombs (Ref 9, p 31)

Bomba atomica. Schematic Fig and description on p 700 of Ref 13

Booster. See "Multiplicador"

Cápsulas detonadores (Blasting Caps). A general description is given in Vol 2 of Encycl, B185 to B200. A brief description of Spanish caps is given by González in Ref 11, p 26

Cargas de propulsion. Charges for propelling rockets (Ref 13, p 31)

Cargas de proyección. Charges for propelling artillery shells (Ref 13, p 31)

Cargas huecos. Hollow or shaped charges (Ref 9, pp 39 to 55)

Cargas incendiarias. Incendiary charges (Ref 13, p 381)

Cargas macizas. Solid (not shaped) charges

Cargas rompedoras. Bursting charges for shells and bombs include HE's such as TNT (Trilita) and its castable blends with PETN (Pentrita), or RDX (Exógeno); Picric Acid (Picrinita) in castable mixts such as Trimonita (qv); phlegmatized PETN or RDX; and many other expl formulations as listed thruout this Spanish Section

Cartuchos (Cartridges). They can be subdivided into:

Cartucho completo — Complete Round

Cartucho de bala — Ball Cartridge

Cartucho de calibre reducido — Subcaliber Cartridge

Cartucho de dinamita — Dynamite Cartridge

Cartucho de granada de fusil — Rifle Cartridge

Cartucho de inflamación — Ignition Cartridge (for proplnts)

Cartucho de percusión central — Center Fire Cartridge

Cartucho fixo — Fixed Round

Cartucho incendiario — Incendiary Cartridge

Cartucho perforante — Armor Piercing Cartridge

A general description of cartridges is given in Vol 2 of Encycl, C70-R to C79-R. Spanish cartridges are similar to them. See also Refs 8, pp 255-56; 13, pp 32 & 100; and Ref 18

Cebos y Estopines. Accdg to the translation given in TM 30-500, listed here as Ref 8, they are **Primers**, but no difference between them is defined. From definitions given in "Spanish-

Russian Military Dictionary", listed here as Ref 20, one might deduce that *Cebo* initiates by *detonation*, while *Estopin* acts by *ignition*. The definition for *Estopin* given by Sancho (Ref 1, p 371) states that they are devices for igniting propelling charges. They are probably similar to US Primers used for igniting propelling charges, which are illustrated in Vol 4 of Encycl, p D793-96, under "Detonators, Igniters and Primers"

Cebos are, accdg to Vivas et al (Ref 6, Vol 1, p 29) are expl substances located in firearms for producing explns. This is a rather unclear definition

Cebos, accdg to Jiménez (Ref 9, p 63), may be subdivided into: *Cebos ordinarios* which consist of a Cu capsule filled with initiating expls. Their function is to create a shock necessary to develop a detonation wave; and *Cebo reglamentario* is reduced to a Cu cap 4.5cm long and 6mm in diam charged with 2g of Fulminating mixt. Commercial Primers are shown in a Table on p 63. They range from No 3 to No 8, contg Fulminate from 0.54 to 2.0g in wt

On p 70 of Ref 9 are described *Cebos eléctricos*, which are subdivided into *Cebos de cantidad* (contg an incandescent filament) and *Cebos de tensión* (contg a filament which breaks, thus creating a spark)

González (Ref 11) describes and illustrates on p 25 a *Cebo del detonador*, while on p 40 are described *Cebos eléctricos*

Cheditas (Cheddites). A detailed description of chlorate and perchlorate Cheddites (*Street Explosives*) is given in Vol 2 of Encycl, C155 to C164. Jiménez (Ref 9, p 139) gives the compn of one of the Spanish Cheditas as: Na chlorate 79, DNT (Dinitrotoluene) 16, and castor oil 5%, and its properties as: loading d, 1.39g/cc; brisance by Kast formula, 24 (TNT 86); heat of expln, 1185cal/g; expln temp, 4500°; vel of deton, 3000m/sec; and vol of gases developed on expln at 0° and 760mm, 335ℓ/kg. Its uses in Spain were not indicated in the ref, but judging by its properties it was suitable for use as a non-permissible mining expl

Ciclonita, Exógeno or T4. See under "Hexógeno"

Colodio. Collodion Cotton. See under "Nitrocelulosas"

Coronita (Coronite). Coronita is mentioned by Jiménez (Ref 9, p 30) as one of the Spanish expls without giving its compn. The compn of a Brit Coronite is given in Vol 3 of Encycl, C543-R

Detonadores (Detonators). A general description is given in Vol 4 of Encycl, D842 to D850 under "Detonators, Igniters, Primers and Other Initiating Devices". A Spanish complete Detonator (*Detonador completo*) consists of a *cebo* (primer), *mecha lenta* (slow fuse), and an *encendedor* (lighter or igniter). (Ref 9, p 65; Ref 11, p 25; Ref 13, pp 100, 375 & 410)

Dinamitas (Dynamites). A detailed description of Dynamites is given in Vol 5 of Encycl, D1584 to D1742

Accdg to Jiménez (Ref 9, pp 23-27), Spanish Dynamites can be subdivided into two groups with variable compns:

1) **Dinamitas a base inerte** (Dynamites with inert base). To this class belong the compns contg 75, 50 or 30% NG & kieselguhr. They are called No 1, 2 & 3 depending upon the NG content. Dynamite 3 is the most popular type

2) **Dinamitas a base activa** (Dynamites with active base). These Dynamites contain a combustible material or expl material as the active base. The type of base material used further divides these into classes:

- a) *Dinamitas a base de nitratos*. Nitrates of Amm, Na or K and a combustible such as carbon, sawdust or flour
- b) *Dinamitas a base de chloratos*. Chlorates of K or Na are used in place of nitrates
- c) *Dinamitas gelatinas*. Contain Collodion Cotton in sufficient proportion to gelatinize the NG. When the compn contains only NG & Collodion Cotton, it is called **Goma**. All others are called *Gelatina dinamita*, *Nitrogelatina* or simply *Gelatina*. If a Dynamite less sensitive than Gomas is desired, 3-5% of camphor is added. Such compns are called **Gelatinas explosivas de guerra** (Military Gelatins)

All Spanish Dynamites are classed and manufd as industrial expls. The **Goma pura** (pure Goma) type, the most powerful, is used in underwater blasting; **regular Goma**, less powerful, is used in blasting hard rocks; all other types are used in demolition and general blasting operations

In Vol 3 of Encycl, C441-R, are described four Dinamitas de goma de la Fábrica de Dinamita de Galdácano. They were originally described by Vivas, Feigenspan & Ladreda (Ref 6, pp 397-98)

Dinamita goma. See "Gelatina goma"

Dinamones (Dynammons). A general description is given in Vol 5 of Encycl, D1772-R to D1773-L. Spanish Dinamones are, accdg to Jiménez (Ref 9, p 29), Explosivos de seguridad (Permissible explosives) similar to *Amonitas* (qv), except that they do not contain Al or aromatic nitrocompds. As examples are cited: Explosivos de seguridad numeros 2, 5 y 7. Dinamonitas numeros 1, 2 y 2 especial are listed by Jiménez without giving their compns

Donarita (Donarite). A mining expl similar to the Ger "Donarits" (Vol 5, D1531). It contains AN 80, TNT 12, NG (gelatinized) 4, and wood-meal 4%, and its props are: loading d, 1.1g/cc; brisance (by Kast formula), 51 (TNT 86); heat of expln, 930cal/g; temp developed on expln, 2620°; vel of deton, 4000m/sec; and vol of gases at 0° and 760mm pressure, 900l/kg (Ref 9, p 139)

Encendedor. Igniter or lighter

Espoletas (Fuzes). A general description of Fuzes is given in Vol 6 of Encycl, F255 to F259

Spanish fuzes may be subdivided, accdg to Ref 8, p 289 into:

- Espoleta de acción unica – Single-action fuze
- Espoleta de bomba – Bomb fuze
- Espoleta de concusión – Concussion fuze
- Espoleta de culote – Base (tail) fuze
- Espoleta de doble efecto – Combination fuze

Espoleta de fricción – Friction fuze
Espoleta de ojiva – Nose fuze
Espoleta de percusión – Percussion (impact) fuze

Espoleta de radioproximidad – VT fuze
Espoleta de retardo – Delay fuze
Espoleta de tiempos – Time fuze, aerial burst type

Espoleta instantanea – Instantaneous fuze
Espoleta mecanica – Mechanical fuze
Espoleta de ferforante de hommígon – Concrete-piercing fuze

Espoleta química – Chemical fuze

(See also Ref 9, p 65 & Ref 13, pp 23, 31, 36, 55, 65, 99 & 375)

Estopinas. See definition under "Cebos y Estopinas". Accdg to **TM30-500** (Ref 8, p 291), there are Estopinas de fricción, de percusión, detonante and eléctrico (See Ref 13, pp 31, 74 & 99)

Explosivos cloratado (Chlorate explosives). This class of expls contains 60-80% of chlorates or perchlorates (of Na, K or Amm) with combustible materials (such as C, S or Al), or organic substances such as vaseline, paraffin or oils

Some examples of these expls are called *Chedita* (qv), and Cloratita, Coronita, Explosivos tipo O, Minelita and Trinolita. Their properties are similar to those of AN expls, except that they have higher densities and are somewhat more sensitive to impact. It is recommended that a strong Detonator such as No 7 or 8 be used for their initiation

Chlorate expls such as Cheditas or Cloratitas can be used to advantage as substitutes for regular Dynamites in mining operations (Ref 17, p 434)

Explosivos de no Seguridad. See "Explosivos Industriales de no Seguridad"

Explosivos de Seguridad. See "Antigrisú Explosivos" and "Explosivos Industriales de Seguridad"

Explosivos Industriales de no Seguridad (Industrial Explosives of Nonpermissible Type). The following expls are listed in Vol 3 of Encycl, C441-R to C442-L: Amonals, Amonita numero 5, Dinamitas de la Fábrica de Galdácano (Viscaya), Donarita, Explosivos FE, Nitramita espanola de la Fábrica de Granada, Plomoplastrita, Sabulitas espanoles núm 0 y núm 1, Tonita and Triplastita

Explosivos Industriales de Seguridad, o Explosivos Grisú (Industrial Permissible Explosives). The following expls are listed in Vol 3 of Encycl, C454-R to C455-L: Antigrisú explosivos números 1, 2 & 3, Astralita antigrisutosa, Explosivos de seguridad números 2, 5 & 7 de la Fábrica de Dinamita de Galdácano, Explosivo de seguridad núm 3, Grisunaftalita, Grisutitas capa, Grisutitas roca, Nitramita de la Fábrica de Galdácano, Nobelita antigrisú gelatinizada, and Sheathed Cartridges (Cartuchos con corteza de seguridad)

Explosivo Plastico "La Maranosa". A Spanish plastic expl consisting of RDX 85, rubber 5.5 and gelatinizing oil 9.5%. It is a powerful expl of low sensitivity which decomp at 200° without expln, but with the evolution of heavy nitrous fumes, leaving a carbonaceous residue. It burns when ignited with a flame, but does not expld (Ref 13, p 409). Another name for plastic expls is *Explosivos Adoptables* (Flexible Explosives) (Ref 13, pp 408 & 409)

Explosivos Primarios y Iniciadores (Priming and Initiating Explosives). Because of the danger of using Mercury Fulminate Blasting Caps in gaseous mines, the following priming and initiating compns were developed by La Sociedad de Dinamita Nóbél: a) Picric Acid 85, K chlorate 5 & Al 10%; b) Trinitrocresol or Trinitroresorcinol (Styphnic Acid) 65 & K chlorate 35%; c) Trinitronaphthalene 45, Dinitrophenol 10, Hg thiocyanate 10 & K chlorate 35%; and d) AN 30, K chlorate 42, S 10 & Al 18% (Ref 1, pp 192-93 & Ref 17, pp 434-35)

Explosivos Rompedores (Breaking, Bursting and High Explosives). Accdg to F. de Salas López (Ref 13, pp 96-97) they are subdivided into four groups, namely: *Group I* - Definite chemical compds, very stable (such as TNT, PETN & RDX); *Group II* - Definite chemical compds, stable (probably Tetryl & NC); *Group III* - Blends of homogeneous expls, very stable (such as Pentolite and Cyclotol); and *Group IV* - Mixts of heterogeneous expls (such as Dynamites & AN expls)

Fulminato de Mercurio (Mercuric Fulminate). MF is described in Vol 6 of Encycl, F217-L to F223-L, and in Ref 13, p 405

Jiménez (Ref 9, p 139) gives the properties of Spanish MF as follows: loading d, 4.42g/cc; vel of deton, 5400m/sec; expln temp, 180°; impact sens, 2kg wt, 4cm; heat of expln, 368 cal/g; temp developed on expln, 4450°; brisance, 128 (TNT=86); and vol of gases at 0° and 760mm pressure, 315ℓ/kg

Fulminato de mercurio has been generally replaced in primer and detonator use by Azido de plomo (qv) with Stifnato de plomo (qv)

Gelatina Dinamita de 60%. Accdg to Jiménez (Ref 9, p 139) its props are: loading d, 1.6g/cc; brisance by Kast formula, 148 (TNT=86); heat of expln, 1295cal/g; temp developed on expln, 3700°; vel of deton, 6100m/sec; vol of gases at 0° and 760mm, 630ℓ/kg

Gelatina Explosiva de Guerra (Military Gelatin Dynamite). A Dinamita goma to which 3-5% camphor or other plegmatizer is added. It results in a more stable expl, less sensitive to rifle bullet impact. It burns in air without detonation (Ref 9, p 25)

Gelatina goma o Dinamita goma. The most powerful Spanish commercial nonpermissible expl, consisting of 92-93% NG and 28-27% Colloid Cotton. A general description is given in Vol 2 of Encycl, B211-R to B212-L. The properties of Spanish Blasting Gelatin, as listed by Jiménez (Ref 9, p 139), are as follows: loading

d, 1.63g/cc; heat of expln 1610cal/g; temp developed on expln, 4460°; vel of deton, 7500 m/sec; vol of gases at 0° & 760mm, 711ℓ/kg; and brisance value by Kast formula, 148 (TNT 86)

Hexalita, Hexil, Hexamina (Hexanitrodiphenylamine). A detailed description is given in Vol 5 of Encycl, D1434-R to D1440-R. The properties of the Spanish compd are given in Ref 9, p 139 as follows: d 1.67g/cc; brisance by Kast formula, 111 (TNT 86); heat of expln, 1035cal/g; temp developed on detonation, 3450°; vel of deton, 7150m/sec; and vol of gases at 0° and 760mm, 675ℓ/kg

This powerful HE has been used in admixtures with TNT to form a castable bursting charge for grenades, mines and torpedoes. See also under "Amatolos" in this section

Hexógeno, Exógeno, Ciclonita o Explosivo T4 (RDX or Cyclonite). See general description in Vol 3 of Encycl, under "Cyclotrimethylene-trinitramine", C611-L to C630-L

Jiménez (Ref 9, p 139) gives the following properties for pure Spanish Exógeno: density 1.7g/cc; brisance by Kast formula, 188 (TNT 86); heat of expln, 1500cal/g; temp developed on expln, 3700°; vel of deton, 8380m/sec; and vol of gases on expln at 0° and 760mm, 908ℓ/kg (See also Ref 6, Vol 2, p 280, & Ref 13, p 404)

Its castable mixts include *Tritolita* and *Tritolital* (qv in this section) (Ref 9, p 31)

Hexógeno Plástico, Plastex o PE. A plastic expl similar to Composition C Type (see in Vol 3 of Encycl, C484-L to C488-R), prepd by coating granular RDX with 12% vaseline and other oily substances. The product is a yellow-colored plastic material which can be cut, perforated and handled without extra precaution. It is readily initiated by a Blasting Cap or various Detonators. In extreme climates, this expl must be stored in protected areas. It is used without any casing in some demolition applications (Ref 9, p 22; Ref 17, p 434)

Hexonitas (Hexonites). Expls proposed by A.

Stettbacher consisting of RDX and NG, with or without added Collodion Cotton (See Vol 7 of Encycl, H93-R). They were similar in compn to *Pentritas* (qv), but slightly less brisant, and tended to exude

Spanish *Hexonitas* consist of RDX 80 or 50 and NG 20 or 50%, with some contg RDX, NG and PETN. The 50/50 compn can be gelatinized further and plasticized by including some Collodion Cotton, such as in RDX 50, NG 46 and Collodion Cotton 4%. This powerful expl is known as *Hexonita gelatinizada* (Ref 9, p 31 and Ref 17, p 436)

Macarita. Same as Belg expl called *Macarite*, which consisted of Pb nitrate and TNT (Ref 9, p 31 & Ref 6, Vol 2, p 381)

MAT. Same as Ital expl which contd Picric Acid (PA) 60 and TNT 40%. Used as a bursting charge in some ammo (Ref 9, p 30)

MBT. Same as Ital expl having this designation. It contd PA 60 and Dinitrophenol (DNPh) 40%. Was used as a bursting charge in some ammo (Ref 9, p 30)

MDN. Same as Fr expl having this designation. It contd PA 80 and Dinitronaphthalene (DNN) 20%. Was used as a bursting charge in some ammo (Ref 9, p 30)

MDP^c. Same as Fr expl having this designation. It contd PA 55, DNPh 35 and Tetranitrocresol. Was used as a bursting charge in some ammo (Ref 9, p 30)

Mechas (Fuses). They can be subdivided into: *Mecha lenta o ordinaria* (slow or Bickford Fuse) and *Mecha rápida, Mecha instantanea o detonante* (rapid fuse, Cordeau or detonating fuse)

A general description of Bickford Fuse, also known as Miner's or Safety Fuse is given in Vol 2 of Encycl, B112-L & R. Spanish *Slow Fuse* consists of a BlkPdr core, surrounded by

two layers of hemp. Their diameter is 5mm and burning rate 50 to 60cm/min for *Mechas reglamentarios*. Some *Mechas del comercio* burn at a rate of 1 meter/90 secs. *Mechas impermeables* and *Mechas ordinarias* are covered with a rubber jacket (Ref 9, p 60)

A general description of Detonation Fuses is given in Vol 3 of Encycl, C529-R to C531-L. Spanish *Rapid Fuse* consists of a PA (or other brisant HE) core enclosed in a tube of 3.5mm diam made of Sn-Pb alloy. Its deton velocity is from 3 to 7km/sec (Ref 9, pp 62-63 and Ref 13, pp 100 & 410)

MMN. A HE mixt used as a bursting charge consisting of PA 70 and Mononitronaphthalene 30%, and identical with a Fr mixt known under the same designation (Ref 9, p 31)

MTTC. A HE mixt used as a bursting charge consisting of PA 55, TNT 35 and Dinitrophenol 10% (Ref 9, p 31)

Multiplicador (Booster). A general description is given in Vol 2 of Encycl, B243-R to B246-R

Accdg to de Salas (Ref 13, pp 100 & 375), multiplicadores can contain charges of Trilita (TNT) or Tetralita (Tetryl), although most frequently Tetrytol (Tetrytol) is employed

Nitrata Amónico (Ammonium Nitrate). Its detailed description is given in Vol 1 of Encycl, A311-L to A370-R. The props of the Spanish made salt are given by Jiménez (Ref 9, p 139) as follows: density, 1.2g/cc; brisance by Kast formula, 13 (TNT 86), heat of expln, 350cal/g; temp developed on expln, 1230°; vel of deton, 2500m/sec; and vol of gases developed on expln at 0° and 760mm, 980l/kg

AN is one of the principal components of composite expls and proplnts, such as the following compns described in this section: Amatex, Amatolos, Amonales, Amonitas, Anagon, Antigrisú (Explosivos), Astralita, Dinamitas, Dinamones, Donarita, Explosivos Industriales, Minolex and Sabulita

Nitrocelulosas (Nitrocelluloses, NC's) o Piroxilanes. A general description of NC's is given in Vol 2 of Encycl, C100-L to C125-R

Spanish NC's are subdivided, accdg to Sancho (Ref 1, p 324) and Vivas, Feigenspan and Ladreda (Ref 6, Vol 1, p 108) into *Algodón fulminante* and *Algodón colodio*:

a) *Algodón fulminante, Algodón pólvora o Fulmicotón* contains not less than 13% N and is practically insol in 2:1 eth-alc. It corresponds to US *Guncotton* and to formula $C_{24}H_{29}(ONO_2)_{11}O$. Its props, accdg to Jiménez (Ref 9, p 139) are: density, 1.3g/cc; brisance by Kast formula, 77 (TNT 86); heat of expln, 1050cal/g; temp developed on expln, 3150°; vel of deton, 6800m/sec; and vol of gases on expln at 0° and 760mm, 765l/kg. Its principal use is in smokeless proplnts. Accdg to Ref 1, p 326, it forms very powerful mixts with nitrates, as for example, Fulmicotón 51.6 and Ba nitrate 48.4%, known as *Tonita* (qv). A mixt of Fulmicotón 57.7 and K chlorate 42.3% was proposed for use in Detonators. *Algodón pólvora* is also used in *Triplastita* (Ref 9, p 31)

b) *Algodón colodio o Cotone Colodio* has about 12% N content (Ref 6, p 108). Its props are practically identical to those of US *Collodion Cotton*, described in Vol 2 of Encycl, C103-R to C105-L. It is used in NG or NGc (Nitroglycol) contg expls, such as *Dynamites* and *Plastrita* (Ref 9, p 31)

Nitroglicerina o Aceite Explosivo (Nitroglycerin). A general description of its prepn, props and uses is given in Vol 6 of Encycl, G98-R to G108-L

Jiménez (Ref 9, p 139) lists the following props of NG: density 1.6g/cc; brisance by Kast formula, 145 (TNT 86); heat of expln, 1465 cal/g; temp developed on expln, 4250°; vel of deton, 7400m/sec; and vol of gases developed on expln at 0° and 760mm, 716l/kg

Nitroglicol (Nitroglycol, NGc, Ethyleneglycol Dinitrate). A general description is given in Vol 6 of Encycl, E259-R to E279-L

No description of the Spanish made compd is given by Jiménez (Ref 9), however, Vivas et al (Ref 6, Vol 2, p 37) lists the following props: liq with d 1.496g/cc at 15°; freezing pt, -223°;

sl sol in w, 6.8%; more toxic than NG; detonates on heating or impact; slightly more powerful than NG; temp developed on deton, 3196°; it is not as good a gelatinizing agent for NC's as is NG

NGc has been used in some Spanish NG contg expls for lowering the freezing pt of liq components. Vivas et al (Ref 6, Vol 2, p 39) indicate that a 40:60 NGc:NG mixt is practically nonfreezing. Dinamitas using such mixts are known as *Dinamitas gomias incongelables*

Nitropenta o Nitropentaeritrite. See "Pentrita"

Nitruro de plomo. See "Azido de plomo"

Oxiliquita y Aire liquido. Expl mixts of liq oxygen or liq air with finely pulverized charcoal, cork dust or other absorbent fuel (Ref 9, pp 32 & 139)

Panclastitas. Liq expl mixts of nitrogen peroxide and a liq combustible. Mixing is performed *in situ* (Ref 6, Vol 2, p 340). Jiménez (Ref 9, p 32) lists aliphatic hydrocarbons and aromatic nitrocompds as fuel choices

PE o Plastex. See "Hexógeno Plastico"

Pentolita o Pentritol (Pentolite). A castable compn of PETN 50 and TNT 50%. See in Vol 8 of Encycl, P133-R to P136-R

Pentrita (Penthrinit). A very powerful expl blend of PETN 70 and NG 30%, developed prior to WWI by A. Stettbacher of Switzerland (Ref 10). Its props, as reported by Jiménez (Ref 9, p 139), are as follows: density, 1.72g/cc; brisance by Kast formula, 178 (TNT 86); heat of expln, 1480cal/g; temp developed on deton, 4120°; vel of deton, 8400m/sec; and vol of gases developed on expln at 0° and 760mm, 770l/kg

This compn can also be further gelatinized by the addn of Collodion Cotton (CC) to give a

plastic compn consisting of PETN 50, NG 46 and CC 4%. This compn is known as *Pentrita gelatinosa* (Ref 6, Vol 2, p 399; Ref 9, p 31; & Ref 17, p 439)

See also in Vol 3 of Encycl, C443-R, and Vol 6 of Encycl, G51-L & G52 (Table G17)

Pentrita, Nitropenta o Nitropentaeritrita (Penterythritol Tetranitrate, PETN). PETN is described in Vol 8 of Encycl, P86-R to P121-R

Jiménez (Ref 9, p 139) gives the following props for Spanish made PETN: density 1.7g/cc; brisance by Kast formula, 193 (TNT 86); heat of expln, 1526cal/g; temp developed on deton, 4248°; vel of deton, 8600m/sec; and vol of gases developed on deton at 0° and 760mm, 780l/kg

Straight PETN has been used as a secondary charge in Boosters and Detonators. When phlegmatized with 5–10% paraffin, it was used as a bursting charge in antiaircraft projectiles, mines and demolition charges. Used as a principal component in Pentrita and Pentritol (Ref 9, p 19; Ref 13, p 406; & Ref 17, p 439)

Pentritol. Same as "Pentolita"

Petardos. Accdg to de Salas López (Ref 13, pp 100 & 411), *Petardos Espanoles* are expl (Trilita, Tetralita o Ácido Pícrico) cartridges (blocks) provided at one end with a cylindrical orifice for a Cebo (Primer) or Capsula (Blasting Cap). *Petardos Reglamentarios* (Standard Petards) consist of Trilita (TNT) blocks wrapped in paraffined paper or electrolytic Cu sheet.

González (Ref 11, p 38) contains an illustration of a typical rectangular boxed Petardo; there are also cylindrically-shaped blocks

Picrato Amónico. Ammonium Picrate, Explosive D or Dunnite. It is described in Vol 8 of Encycl, P276-R to P279-L

Picric Acid. See "Picrinita"

Picrinita, Ácido Pícrico o Trinitrofenol. Picric

Acid (PA) or 2,4,6-Trinitrophenol. It is described in Vol 8 of Encycl, P285-R to P296-L

The properties of Spanish-made PA are listed by Jiménez (Ref 9, p 139) as follows: density, 1.69g/cc; brisance by Kast formula, 107 (TNT 86); heat of expln, 1000cal/g; temp developed on expln, 3230°; vel of deton, 7250m/sec; and volume of gases developed on expln at 0° and 760mm, 675ℓ/kg

PA was manufd at LaFábrica del Arma de Artillería (Ref 11, p 18)

Pressed PA has been used in mining operations as the core of Detonating Cord (Mecha rápida or Mecha detonante) (Ref 9, p 20). It was also used in composite expls, such as Tridita (qv) and Trimonita (qv). Its Amm salt is described above as *Picrato Amónico*

Pirotecnia y Artificios (Pyrotechnics and Fireworks). A general description of Pyrotechnics is given in Vol 8 of Encycl, P504-R to P526-L

Spanish military pyrotechnic compns can be divided, accdg to Sancho (Ref 1, p 353) and Vivas, Feigenspan & Ladreda (Ref 6, Vol 2, p 367), into three principal groups: a) *Producidos de luz* (light producing), which can be subdivided into illuminating, colored, sparking and double compns; b) *Producidos de gases* (gas producing), which can be subdivided into parachute, smoke, disinfecting smokes and extinguishers; and c) *Producidos de una llama viva y de una temperatura elevada* (intense flame and high temperature producing), which can be subdivided into incendiaries, combustible mixts with oxidizers, and flammable liqs

Many pyro compns are listed in Ref 1, pp 351-60 and Ref 6, Vol 2, pp 357-70, but it is not specified which are used by the Spanish Armed Forces

Plastrita. An exptl compn consisting of granular TNT and Algodón colodio (Collodion Cotton). It is a thick plastic paste, less powerful than straight TNT (Ref 6, Vol 2, p 380 & Ref 9, p 31)

Plomoplastrita o Ploplastrita. A mixt of *Plastrita* with pulverized Pb nitrate. It is less sensitive to impact than TNT and equal in power to TNT on

a wt basis. It is, however, more powerful than TNT on a vol basis due to its high density.

Another advantage is that it does not produce noxious gases on deton

Plomo plastrita was developed for use as a bursting charge in artillery shells, grenades, and in mining applications (Ref 6, Vol 2, p 331; Ref 9, p 32; Ref 17, p 441)

Pólvoras Negras (Black Powders, BlkPdrs). A detailed description of various BlkPdr formulations is given in Vol 2 of Encycl, B165-R to B179-R

Spanish *Pólvoras Negras* are subdivided, accdg to Jiménez (Ref 9, p 17), into: a) *Pólvora de guerra* (Military Powder) contains K nitrate (salitre) 75, charcoal (carbón) 12.5 and sulfur (azufre) 12.5%; b) *Pólvora de caza* (Sporting Powder) contains K nitrate 80, charcoal 11 and sulfur 9%; and c) *Pólvora de mina* (Blasting Powder) contains K nitrate 80, charcoal 11 and sulfur 20% (?). Its props are given in Ref 13, p 399

The properties of *Pólvora de guerra* (Ref 9, p 139) are: density, 1.2g/cc; brisance by Kast formula, 1.4 (TNT 86); heat of expln, 665cal/g; temp developed on expln, 2380°; vel of deton 400m/sec; and vol of gases developed on expln at 0° and 760mm, 280ℓ/kg. It can be ignited by spark or hot wire, and more difficultly, by flame or percussion. Its ignition temp varies between 270° and 320° and it is very sensitive to friction. The hygroscopicity is inversely proportional to the size of the grains (Ref 17, p 441)

Sabulita (Sabulite). Mixts of AN, TNT and Ca silicide, the latter compd serving to increase the heat of expln of the mixt. The 78/8/14 formulation is known as *Sabulita núm 0*, while the mixt contg 12% Ca silicide is *Sabulita núm 1*

Sabulitas are very powerful expls, which are used for both military and industrial applications (Ref 6, Vol 2, p 382 & Ref 17, p 441)

The name Sabulita is also applied to some mixts contg K perchlorate in place of the AN (Ref 17, p 441)

Stifnato de plomo, Trinitroresorcinato de plomo, Triginato o Tricinato (Lead Styphnate, LSt).

Described in Vol 5 of Encycl, D1277-L to D1288-L

The props of Spanish made LSt (Ref 6, Vol 2, pp 324–25) are: loading d, 2.9g/cc; mp, explds at 282° in 5 secs; brisance by sand test, 50% TNT; impact sens with 2kg wt, 7cm; Trauzl test value, 40% of TNT; vel of deton, 5200m/sec. Used as an igniting charge in Pb Azide detonators

Tetraceno (Tetracene). Described in Vol 6 of Encycl, G169-L to G172-R. Used in priming compns as an initiating expl

Tetralita, Tetrilo o Tetranitrometilnilina (Tetryl). Described in Ref 6, p 294; Ref 9, pp 21 & 139; and Ref 19, p 335. Lt-yel crystals; d 1.73g/cc; loading d, 1.65g/cc; mp, 130°; brisance by sand test, 113% TNT; brisance by Kast formula, 116 (TNT 86); expln temp, 257° (5 secs); heat of expln, 1090cal/g; impact sens with 2kg wt, 26cm; temp developed on expln, 3370°; Trauzl test value, 125% TNT; vel of deton, 7250m/sec at d 1.65; and vol of gases developed on expln at 0° and 760mm, 710l/kg

Tetralita has been used in *Multiplificadores* (Boosters), and as a secondary charge in Detonators and as the core of Detonating Cord (Mecha detonante o Mecha rápida)(Ref 13, pp 100 & 403)

Tetralita número 2, Pentralita o Pentanitrodimetilanilina. Described in Vol 5 of Encycl, D1316-L

Tetrytol (Tetrytol). A light yel to buff colored mixt of Tetryl and TNT. The 75/25 formulation has the following props: density (cast), 1.55g/cc; mp, 68°; brisance by sand test, 112% TNT; expln temp, ignites at 310° in 5 secs; impact sens with 2kg wt, 28cm; power by Bal-Mort, 122% TNT; and vel of deton 7385m/sec

Tetrytol is used as a bursting charge in various projectiles (Ref 9, p 30). Ref 13, p 100 states that mixts of Tetralita (Tetryl) and Trilita (TNT) are the most commonly used charges in Spanish Boosters (Multiplificadores)

Tonita (Tonite). A powerful expl mixt of Ba nitrate 68, Dinitrobenzene 13 and Gun cotton 19%. Used as a bursting charge in ammo (Ref 9, p 31). Another formulation for Tonita is given under "Nitrocelulosas" in this section

Torpedos. Accdg to González (Ref 11, p 76), *torpedos* can be used on land (tierra) or in water (en el agua). The land torpedos are located in *hornillos* (small excavations) near flush with the surface of the earth. They usually consist of a hollow charged (cargas huecas) artillery shell or bomb, which is initiated by electric or pyrotechnic Detonators. Torpedos may also be submerged in water (sumergidos en agua) after being waterproofed

Torpex. See "Tritolital" in this section

Tricinato o Trinitroresorcinato de plomo. See "Stifnato de plomo" in this section

Tridita (Tridite). A castable expl mixt of PA 80 and Dinitrophenol 20%, and was used as a bursting charge in shells and bombs (Ref 9, p 30)

Trilita, Trotilo, Tol o Trinitrotolueno (Trinitrotoluene, TNT). Jiménez (Ref 9, pp 20–139) reports the following props for Spanish made TNT: loading d, 1.59g/cc; brisance value by Kast formula, 86; heat of expln, 1000cal/g; temp developed on expln, 2800°; vel of deton, 6800m/sec; and vol of gases developed on expln at 0° and 760mm pressure, 690l/kg. Its characteristics and uses are also described in Ref 13, pp 400–403

TNT is a standard military expl in Spain, but it is not used in mining operations because of the production of noxious gases on expln. It is used as a bursting charge in projectiles, bombs and mines. It is the standard expl of the Pioneers (Zapadores) for demolition use with Petardos (qv in this section) (Ref 11, p 17)

The following composite expls contain TNT: Amatex, Amatolo, Amonal, Baratol, Donarita, Minolex, Pentolita, Plastrita and Tetrytol (Ref 17, p 443)

Trimonita (Trimonite). A castable expl consisting of Picric Acid 90 and Mononitronaphthalene 10% (Ref 9, p 30)

Trinitrophenol. See "Picrinita" in this section

Trinitroresorcinato de plomo. See "Stifnato de plomo" in this section

Triplastita (Triplastite). A gelatinized mixt of Dinitrotoluene and Guncotton (Algodón pólvora). It is less sensitive than TNT and has the advantage of a higher d when compressed. Used as a bursting charge in some ammo (Ref 9, p 31)

Tritolita. A castable expl mixt of RDX 50 and TNT 50%, corresponding to the US *Cyclotol*. It is described in Vol 3 of Encycl, under "Composition B Type Explosives and Cyclotols", C477-R to C484-L. It is used as a bursting charge in ammo (Ref 9, p 32)

Tritolital o Torpex. A castable expl mixt of TNT 60, RDX 20 and Al 20% (Ref 9, p 32). The props of Torpex contg TNT 40, RDX 42 and Al 18% are given in Ref 19, pp 359-63. Used as a bursting charge in depth charges and bombs

Written by **B. T. FEDOROFF**

Refs: 1) E.E. Sancho, "Química de los Explosivos", A. Aguado, Madrid (1941) 1a) G.D. Clift & B.T. Fedoroff, "A Manual for Explosives Laboratories", Lefax, Philadelphia, Vol 1 (1941) & Vol 2 (1943) 2) M.M. Kostevitch, "Espoletas de Tiempo y Pólvoro Negra para los Reguladores Interior y Superior", Tomás Palumbo, Buenos Aires (1943) 3) A. Ernitz, "Manual de Explosivos Industriales", Esmeralda, Buenos Aires (1944) 3a) A.H. Blatt, "Compilation of Data on Organic Explosives", OSRD 2014 (1944) 4) S. de Pablo, Revista de Aeronautica 4, 41-44 (1943) & CA 39, 3159 (1945) [Expls used during Spanish Civil War of 1938] 5) A. Pérez Ara, "Tratado de Explosivos", Cultural, La Habana (1945) 6) J.M. Vivas, J.R. Feigen-

span & J.M. Fernandez-Ladreda, "Pólvoras y Explosivos Modernos", J. Morata, Madrid: Vol 1 (1945), "Introduction al Estudio de Pólvoras y Explosivos"; Vol 2 (1946), "Altos Explosivos o Explosivos Rompedores"; Vol 3 (1948), "Pólvoras"; Vol 4 (1944), "Estudios Teoricos, Pruebas, Analisis y Empleos"; and Vol 5 (1947), "Legislacion y Tablas" 7) L.L. Sell, "Spanish-English Comprehensive Technical Dictionary", McGraw-Hill, NY (1949) 8) Anon, "Spanish Military Dictionary", TM 30-500 (1950) 9) J.M. Jiménez, "Explosivos", Ediciones Ejército, Madrid (1951) 10) A. Stettbacher, "Pólvoras y Explosivos", Gili, Buenos Aires (1952) 11) E.E.M. González, "Explosivos para los Cursos Regionales de Oficiales y Suboficiales de Infantería, Caballería y Artillería", Ejército, Madrid (1955) 12) B.T. Fedoroff, "Spanish Explosives and Propellants", PicArSn Manuscript, Unpublished (1956) 13) Fernando de Salas López, "Empleo Tactico del Armamento", Dosa, Madrid (1960) 14) R.P. Antonelli, "Encyclopedia of Explosives", Ordnance Technical Intelligence Agency, Ordnance Liaison Group, Durham, NC (May 1960) 15) W.H.B. Smith & J.E. Smith, "Small Arms of the World", Stackpole, Harrisburg, Pa (1960), 536-62 16) B.T. Fedoroff et al, "Encyclopedia of Explosives and Related Items", PATR 2700, Vols 1 thru 8 (1960-1978) 17) Anon, "Handbook of Foreign Explosives", US Army Materiel Command, FSTC-381-5042, Washington, DC (Oct 1965), 429-46 18) Ministerio del Ejército, Estado Mayor, "Reglamentos e Instrucciones Vigentes", Talleres del Servicio Geografico del Ejército, Madrid (no date) 18a) L. Carrillo & P. Yates, Technical Translation, "Black Powder Specifications-Spain", FSTC-HT-23-334-68, US Army Foreign Science and Technology Center (1968) 19) Anon, "Properties of Explosives of Military Interest", AMCP 706-177 (1971) 20) Coll, "Spanish-Russian Military Dictionary", Voenizdat, Moscow (1973)

Spanish Commercial Explosives. See under "Spanish Commercial Explosives of Nonpermissible Type" in Vol 3, C441-R, and "Spanish Permissible Explosives" in Vol 3, C454-R

Spanish Infantry Weapons in Current Service. Ref 3 states, "the Spanish Army is equipped with the following weapons: the 9mm Super Star pistol, the 9mm Star Model Z45 submachine gun, the Star 9mm Model Z-62 submachine gun, the 7.92mm Model 43 rifle, the 7.62mm NATO Model 1916 carbine, the 7.62mm NATO Model 58 assault rifle, the 7.62mm NATO FA059 light machine gun, the 7.92mm FAO light

machine gun and the 7.92mm ALFA 1944 heavy machine gun. Spain also adopted the 7.62mm NATO MG 42/59. A quantity has been purchased from Rheinmettal, and series manufacture is being carried on at Oviedo. The US caliber .30 and .50 Browning machine guns are in use on US armored vehicles in the Spanish Army"

Jane's Infantry Weapons (Refs 1 & 2) contains

Table 1

<u>Weapon</u>	<u>Nomenclature</u>	<u>Source</u>
Pistol	9mm Super Star	Manufd by Bonifacio Echeverria Eibar, Spain
Sub-machine guns	9mm Star Z-45 9mm Star Z-62 9mm Star Z-70B	Bonifacio Echeverria Bonifacio Echeverria mainly superseded by the Z-70B Bonifacio Echeverria
Rifles	7.62mm CETME Fusil Asalto 7.62mm Mauser	Designed by the Centro de Estudios de Materiales Especiales, Madrid. It is manufd at Empresa Nacional Santa Barbara at Oviedo, Spain E.N., Santa Barbara
Machine guns	7.62mm MG 42/59 7.62mm MG1AB & 3S 7.62mm MF1 7.62mm Browning M1919A4E1 0.5" M2 Browning	Manufd at Oviedo E.N., Santa Barbara DTAT, France USA USA
Grenades, hand	P011 and 111 E.A. M5	Manufd by Plasticas Oramil SA, St Sebastian Manufd by Explosivos Alaveses, Vittoria
Grenades, rifle	GL1 and GL11 60mm AML 1961	Manufd by Plasticas Oramil SA, St Sebastian DTAT, France
Mortars	60mm EC1A 81mm EC1A 120mm EC1A 60mm AML 1961	Manufd by Esperanza & Cia, Marquina Manufd by Esperanza & Cia, Marquina Manufd by Esperanza & Cia, Marquina DTAT, France
Anti-armor weapons	88.9mm Model 65 Lanzagranadas Canon sin Retroceso 106mm Cobra 2000 ATGW Milan ATGW	Copy of USA 3.5" RLM 20 made by Instalaza SA, Zaragoza Copy of USA RCL Gun 106mm M40. Manufd by E.N. de Santa Barbara, Oviedo MBB, Germany Euromissile
Anti-aircraft weapons	.5 Browning HBM2 20mm Oerlikon La/5TG (towed)	USA Oerlikon, Switzerland

the following table delineating weapon, nomenclature and manufg source of current Spanish Army infantry weapons (Table 1):

Refs: 1) F.W.A. Hobart, Ed, "Jane's Infantry Weapons—1975", Franklin Watts, NY (1974), 841 2) D.H.R. Archer, Ed, "Jane's Infantry Weapons—1977", Franklin Watts, NY (1977), 719 3) E.C. Ezell, "Small Arms of the World", 11th Ed, Stackpole, Harrisburg (1977), 442–52

Spark Sensitivity of Explosives. See under "Electrostatic Discharges and Sensitivity of Explosives to Initiation by Them" in Vol 5, E38-L to E55-L

Sparrow (AIM-7F). US long-range air-to-air missile; in current production and service. Sparrow is one of the most important missiles currently in service with the NATO air forces, their allies and friends

The prime contractor is Raytheon Co, and it is powered by the Hercules Mark 58 Mod O solid propellant rocket motor. The airframe is a slim cylindrical body with a pointed ogive nose. Pivoted cruciform delta wings are mid-way along the body, indexed in line with cruciform delta tail fins. Guidance is a Raytheon semi-active Doppler radar homing system, with control by movable wings

Sparrow contains a HE continuous-rod warhead weighing 88 lbs (40 kg), actuated by proximity or contact fuse. It is 12'0" (3.66m) in length, diameter 8" (0.20m) and wing span 3'4" (1.02m). Its launch wt is 500 lbs (227 kg), max speed above Mach 3.5, and max range 28 miles (44 km)

Refs: 1) M.J.H. Taylor & J.W.R. Taylor, "Missiles of the World", Charles Scribner's Sons, NY (1976), 129 2) R.T. Pretty, Ed, "Jane's Weapon Systems—1977", Franklin Watts, NY (1976), 172–73

Sparte Nitré (Fr). Nitrated esparto grass

Special Area Distances. In the layout of expl manufg and ammo loading plants, each operating line, storage area and administrative area con-

stitute a separate group of buildings and facilities, so located that any group is separated from all others by inhabited building distances. For more information see under "Safety" in this Vol

"Special List" Explosives (Brit). Expls admitted to Engl and placed by Government Decree in 1901 on a "special list" because they were considered safe to use in even the most dangerous (gassy) coal mines. These expls had to be submitted to stricter tests than was prescribed for "permitted explosives". Among the requirements was that they be packed in waterproof paper cartridges, and that they be initiated by a cap not weaker than the No 8, which contained 2g of a mixt consisting of MF 80 and K chlorate 20%
Ref: Daniel (1902), 757 & 767

Specific Force or Pressure. See Vol 2, B105-L to B106-L

Specific Gravity. See under "Density and Specific Gravity and their Determinations" in Vol 3, D64-R to D85-L

Specific Heats of Common Explosives. See Vol 7, H45 to H46

Specific Impulse. See definitions under "Impulse, Specific" in Vol 7, I63-R & L35-L. See also under "Liquid Propellants" in Vol 7, L34-R to L44-R, and "Propellants, Solid" in Vol 8, P402-L to P473-L

Specific Surface Measurements. See under "Particle Size Measurements . . ." in Vol 8, P52-L to P54-L

SPECTROSCOPY OF ENERGETIC MATERIALS

I Introduction

Spectroscopy is the technological area dealing with the interactions of matter and electromagnetic energy, particularly with respect to absorption, emission and reflection properties as a function of wavelength. Absorption and emission processes derive from discrete electronic or molecular transitions among energy states of the system. The energy required for transitions between states is directly related to the frequency of the electromagnetic radiation that causes the perturbation. The energy involved is designated by $E = h\nu$, where h is Planck's constant (6.624×10^{-27} erg sec) and ν is the frequency of the radiation in cycles per second (cps). The frequency and wavelength are related by $\nu = c/\lambda$ where c is the velocity of light (2.998×10^{10} cm/sec). Wave number is also used in the description of spectra. The relationship is $K = 1/\lambda$ where K is the wave number in cm^{-1} (reciprocal centimeters or Kaysers), and λ is the wavelength in cm. The conversion factors for energy to wavelength and frequency are given by the expressions $E = Nh\nu = Nhc/\lambda$, where N is Avogadro's number and E is the energy in ergs. The energy in electron volts is given by $e\nu = 1/8066\lambda$ with λ in cm. Relationships among these quantities are shown in Fig 1

Although no universal instrumentation exists for performing spectroscopic measurements over the entire range of the electromagnetic spectrum, the basic components for each spectral range are similar: (1) a source of incident radiation; (2) a monochromator for providing spectral dispersion; and (3) a detector for measuring signal intensity. Since early in the 1950's, there has been a significant increase in the degree of sophistication of spectroscopic instrumentation, particularly with respect to increased detection sensitivity, computer interfacing and development of rapid scan techniques (Ref 50)

Spectroscopic techniques have proven to be a valuable aid in the identification of reactants and products of explns. By supplying information relative to time dependent compositional and distributional properties, spectroscopy pro-

vides the necessary unifying link between the thermodynamic and kinetic phenomena characteristic of the high energy rapid reactions of expls, propnls and related materials

The origins of spectroscopy can be traced to the work of Sir Isaac Newton who first demonstrated (1666) that a prism could be used to disperse a beam of sunlight into a band of spectral colors. In 1802, William H. Wollaston passed a light beam thru a narrow slit and produced monochromatic images of the slit. Joseph Fraunhofer (1814) produced a similar result with a diffraction grating and discovered the dark absorption lines in the solar spectrum. Although the emission spectra of metals and compds were studied extensively in the 18th and 19th centuries, it was not until Gustav Kirchhoff's laborious purification efforts, that characteristic spectra were determined, which serve as the basis for modern spectroscopic analysis of the chemical composition of matter. The technique was applied by Kirchhoff, in collaboration with Robert Bunsen in 1861, to the analysis of the solar spectrum and identification of the chemical elements in the sun

Prior to the 20th century, no satisfactory theory existed which could explain the origin or significance of spectral properties of matter. The principal discoveries leading to modern understanding of spectroscopic processes include: the discovery of infrared radiation (William Herschel, 1800) and ultraviolet radiation (Johann Wilhelm Ritter, 1801); recognition of harmonic relationships in the hydrogen spectrum (Johann Jacob Balmer, 1885); the discovery of the electron (J.J. Thompson, 1897); the origin of quantum theory (Max Planck, 1900); the formulation of the combination principle (Ernest Rutherford, 1911); and the first theoretical calcons of discrete atomic energy states and emission spectra (Niels Bohr, 1913). Against this background, Erwin Schrödinger and Werner Karl Heisenberg developed quantum mechanics to describe the detailed properties of atomic systems. This theory, extended by Wolfgang Pauli, P.A.M. Dirac, and others, now provides a framework for the calcn of energy states and spectral lines of simple systems as well as a unified model for the interpretation of spectral characteristics of complex systems

II Origin and Interpretation of Spectra

Many classifications of spectra exist: those describing the spectral region involved (ultraviolet, infrared); the appearance of the spectra (line, band); the method of observation (absorption, emission); or the species producing the spectra (atoms, molecules). With respect to processes and properties of expts and proplnts, classification by species is most appropriate since information concerning reaction kinetics is frequently provided by spectroscopic techniques. From a spectroscopic viewpoint, it is convenient to divide the electromagnetic spectrum into a number of sections (see Fig 1). Table 1 illustrates such a division together with a nominal assignment of spectral origin by species and physical phenomenology

Atomic spectra are relatively simple to characterize, in principle. Upon excitation by moderate heating, atoms emit light of characteristic frequencies, corresponding to electronic transitions between low-lying allowed excited states and the ground state. Simple elements such as hydrogen have spectra consisting of relatively few lines. Sodium, excited in a flame, is noteworthy in apparently emitting only a closely spaced visible doublet (D lines). However, if more strongly excited by electric arc or spark, other doublet lines appear which belong to a very

regular sequence called a spectral series. More complex elements such as iron, nickel and neon produce complicated spectra consisting of thousands of lines, from which closely related groups, called multiplets, can be identified. These atomic spectra provide a detailed insight into the electronic structure of the elements. Extensive tabulations of spectral lines of neutral and ionized atoms exist (Ref 29) as well as comprehensive treatments of the theory (Ref 1) and interpretation of atomic spectra (Ref 2)

Molecular spectra are more complex than atomic spectra. In addition to the relatively energetic electronic transitions of the individual atoms, which are manifested by absorption or emission in the ultraviolet and visible spectral regions, rotational and vibrational transitions are also evident. Infrared spectroscopy is therefore very useful for identification of chemical species, since characteristic bond parameters can be identified. The basic techniques relevant to molecular spectroscopy are well characterized (Refs 6, 8, 14 & 48). Extensive spectroscopic data tabulations exist (Refs 3, 4, 5 & 16) as well as comprehensive treatises relating spectral and structural properties (Refs 9 & 48)

Since the origin and interpretation of spectral characteristics depend, to a large extent, on the region of the electromagnetic spectrum involved,

Table 1
Electromagnetic Spectrum

Region	Approximate Range	Source
X-ray	0.006–100Å	Atoms – inner electrons
Vacuum Ultraviolet	100–2000Å	Atoms – outer electrons Molecules – tightly bound inner electrons
Ultraviolet	2000–3800Å	Atoms – outer electrons Molecules – loosely bound and mobile electrons
Visible	3800–8000Å	Atoms – outer electrons Molecules – mobile electrons
Near Infrared	0.8–2.5μ	Atoms – outer electrons Molecules – electrons in low-lying levels vibrational overtones
Infrared	2.5–15μ	Molecules – vibrational, rotational
Far Infrared	15–200μ	Molecules – rocking, relaxation

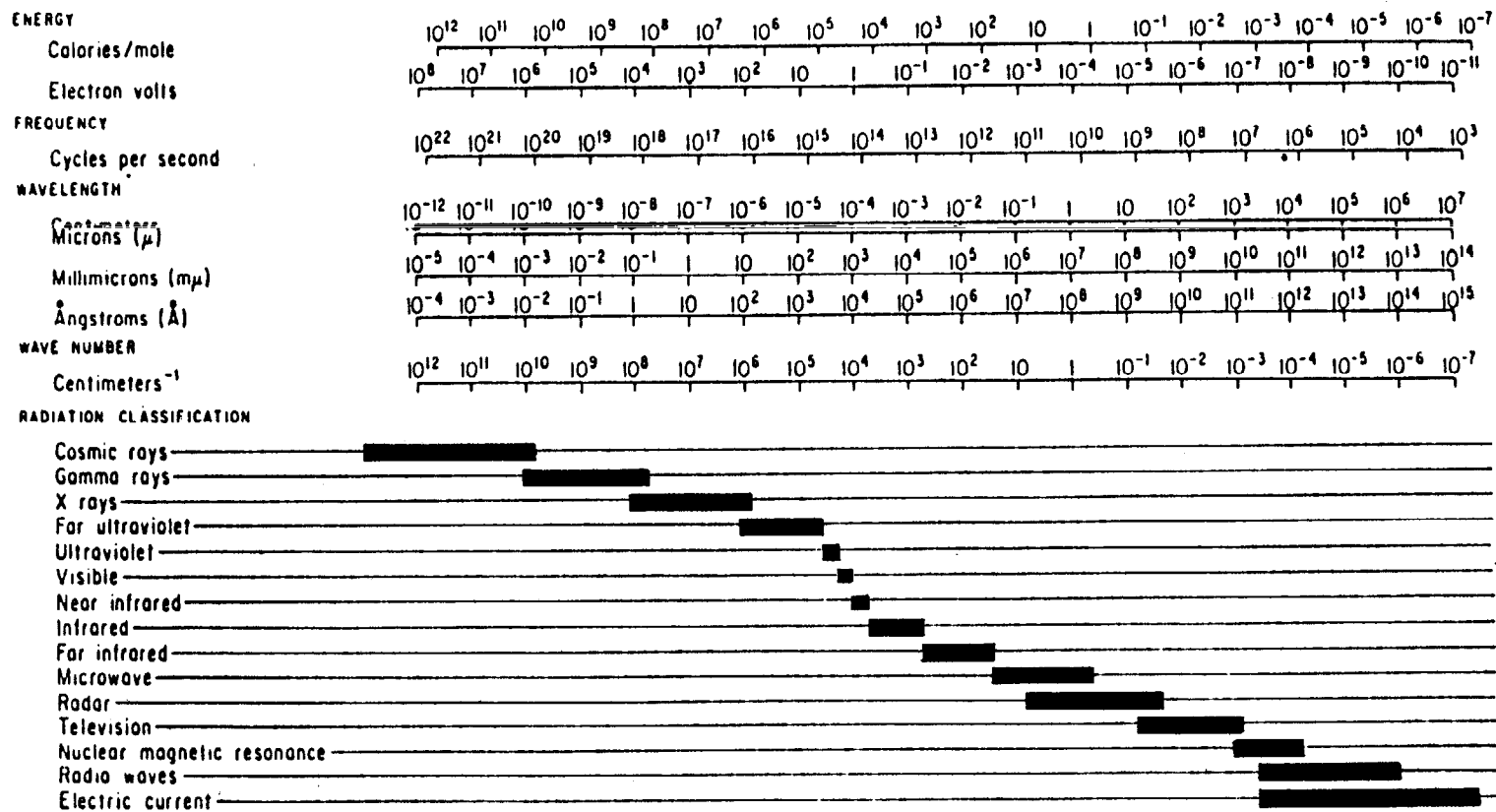

Fig 1 The Electromagnetic Spectrum

it is practical to treat the various aspects of spectroscopy independently. Consequently, the subject matter is addressed with respect to five classifications:

- 1) Thermal radiation
- 2) Ultra-violet spectroscopy
- 3) Visible spectroscopy
- 4) Infrared spectroscopy
- 5) Additional spectroscopic techniques

1) Thermal Radiation

All matter continuously emits radiant energy as a consequence of fundamental atomic, molecular and electronic motions. The max emission is that of a "black body", in which the absorptance and emittance at each wavelength are equal at thermal equilibrium (Kirchhoff's law). The total radiation emitted by a black body per unit time is directly proportional to the fourth power of the absolute temp of the source, in accordance

with the Stephan-Boltzmann law:

$$\phi_b = \delta AT^4$$

The wavelength of max emission was determined by W. Wien to be represented by:

$$\lambda T = 2897 (\mu^\circ\text{K})$$

Max Planck, utilizing his quantum theory postulates and modifications of the Boltzmann statistical procedure, established the theoretical formula for the spectral distribution curves of a black body:

$$W_b = \frac{C_1}{\lambda^5} \cdot \frac{1}{e^{(C_2/\lambda T)} - 1}$$

where: $C_1 = 2\pi^5 c^2 h / 15 = 3.740 \times 10^{-16}$ (watts m^2)

$C_2 = hc/k = 1.438 \times 10^{-2}$ (m°K)

c = velocity of light

k = Boltzmann constant

h = Planck's constant

Black body distribution curves for several temps are shown in Fig 2, from which it can be seen that with increasing temp the total radia-

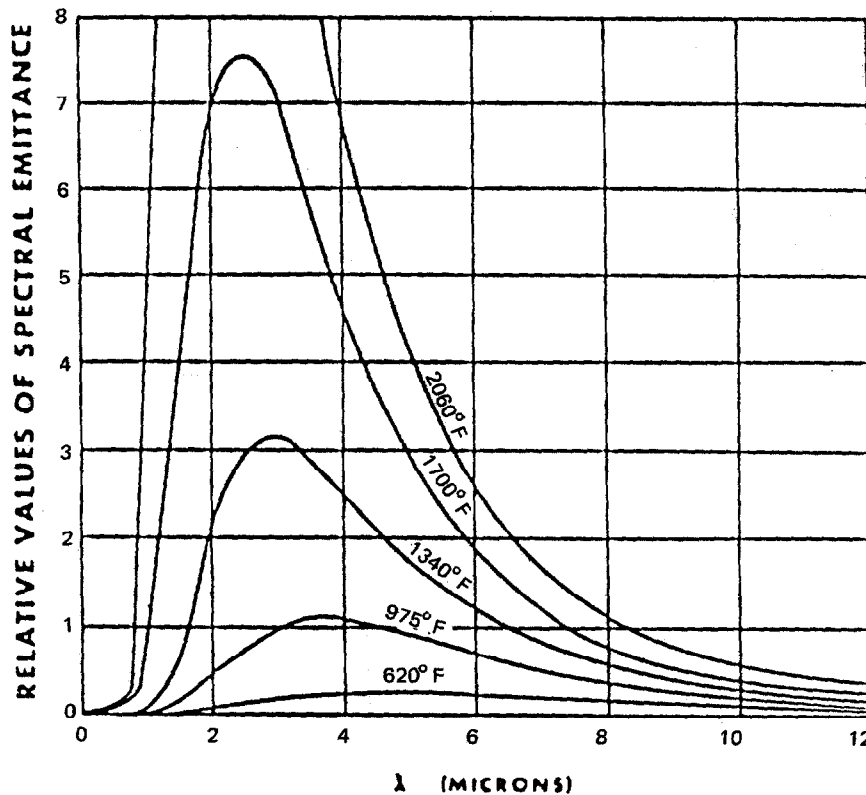

Fig 2 Spectral Distribution of Black Body Radiation as a Function of Temperature

tion increases and the peak wavelength decreases. The percentage of radiated energy as a function of wavelength and temp for a black body is presented in Fig 3

Applications of thermal radiation spectroscopy to explns and pyrots are readily apparent. As a consequence of the highly exothermic nature of explns and flares, significant thermal radiation is emitted which can serve to characterize the reaction processes. The photometric properties of pyrots have been treated in Vol 8, P505-R. In practice, thermal radiation characteristics of explns do not always closely approximate black body properties since the system is non-equilibrium in nature and is time dependent. In addition, some pyrotechnically related materials such as aluminum oxide and magnesium oxide behave as "gray bodies" with emissivities well below unity. For such systems the radiant emission is reduced as shown in Fig 4

Additional deviations from black body theory for practical ordnance systems derive from the fact that all radiant energy emission is proportional to emitting surface area. Although end burning flares present a fairly well defined emitting area, most detonations do not have long-term definitive spatial constraints. Additionally, the production of smoke creates a non-homogeneous scattering medium which can obscure spectral and spatial features

Direct correlation between thermal radiation spectroscopic techniques and thermocouple temp measurements have been obtained for a pyrot mixt containing the agent CS and the simulant 1-methylaminoanthraquinone (Ref 28). Using rapid-scan spectroscopy for time resolution of the reaction, together with two-line analysis and max radiant energy wavelength techniques, the spatial, temporal and thermal history is documented

Large scale propagations of explns involving CH_4 -air, CH_4 -air- N_2 and CH_4 -air- CF_3Br have been shown to be amenable to spectroscopic determination of flame temp and burning velocities (Ref 62). Absolute spectral radiances were obtained (time resolved) in the 1.6 to 4.8 micron range along with radiance growth patterns for the H_2O (2.5 micron) bands as a function of methane stoichiometry. Flame temps were determined from the CO_2 band emissions which approximated unit emissivity

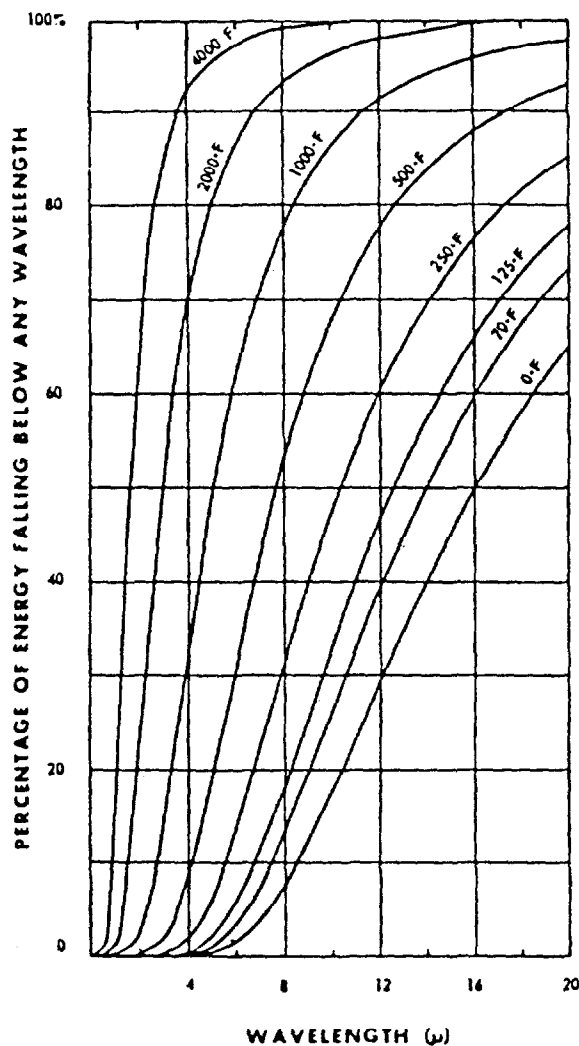

Fig 3 Percentage of Black Body Radiation as a Function of Wavelength and Temperature

The thermal radiative properties of exploding silver wires have been measured using time-integrated and time-resolved spectroscopic techniques (Ref 52)

2) Ultraviolet Spectroscopy

The ultraviolet region is important in spectroscopic studies since it energetically corresponds to electronic transitions in monatomic, polyatomic and free radical species. The vacuum ultraviolet region (1000-2000Å), while significant for many laboratory spectroscopic applications, is relatively unimportant in relation to field applications of explns since atmospheric

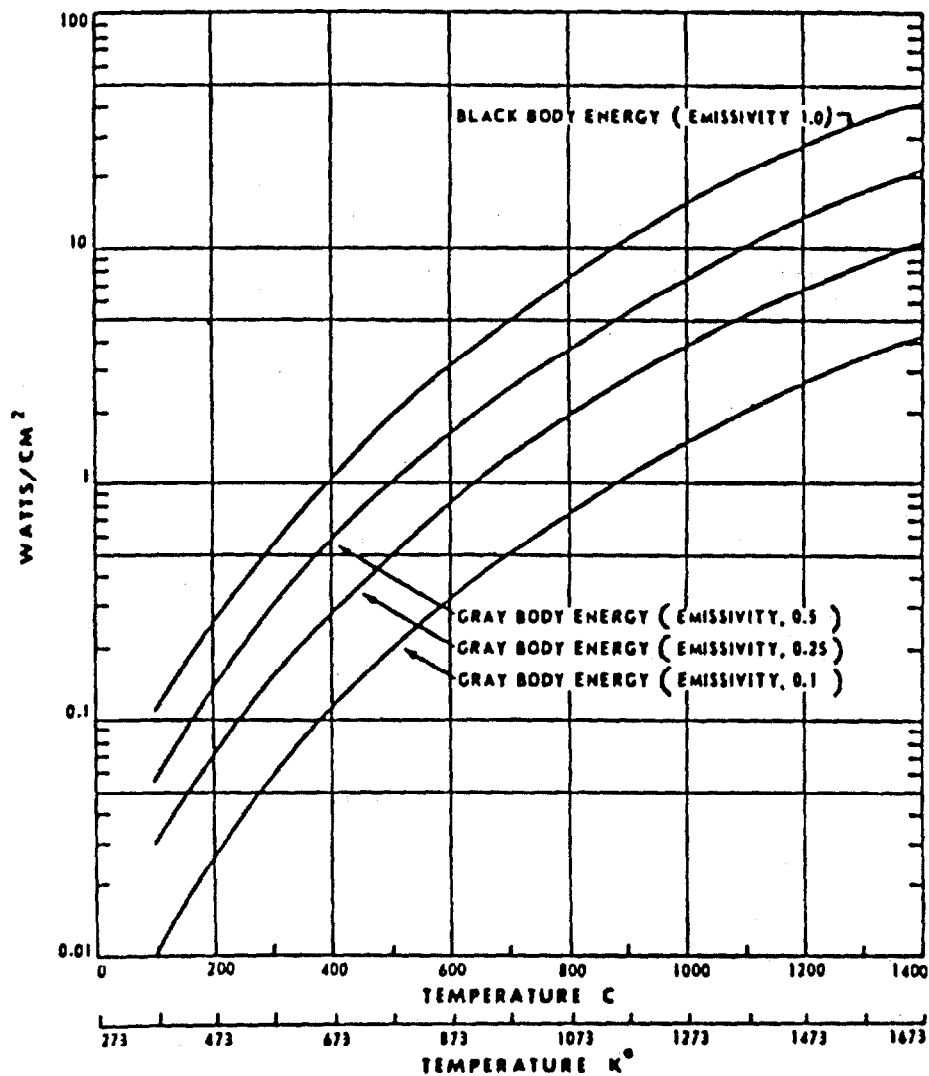

Fig 4 Effect of Emissivity on Radiant Output

absorption tends to obscure spectral features. The spectral region 2000–4000Å (near ultraviolet) encompasses most of the important atomic transitions (Refs 2 & 29) and many of the polyatomic features (Refs 3, 4, 5 & 16)

Applications of ultraviolet spectroscopy to the identification of atomic species and simple polyatomic molecules are well defined (Refs 1, 4 & 6) in that characteristic lines and bands are readily interpretable

The spectroscopy of complex molecular systems, particularly organic materials, is less straightforward. The absorption of energy by organic compds in the ultraviolet region involves promotion of electrons in δ , π and n-orbitals

from the ground state to higher energy states. These higher-energy states are described by molecular orbitals that are vacant in the ground or unexcited state and are commonly called "antibonding orbitals". The precise electronic structures of the excited states are in most cases not well characterized. In general, the polarity is modified and the electron distribution is altered as a result of excitation

Spectral characteristics are frequently affected by the local environment of the material. Increased pressure tends to broaden and shift spectral lines, as does physical state. Fig 5 shows the effect of solvent on the ultraviolet absorption spectrum of benzene

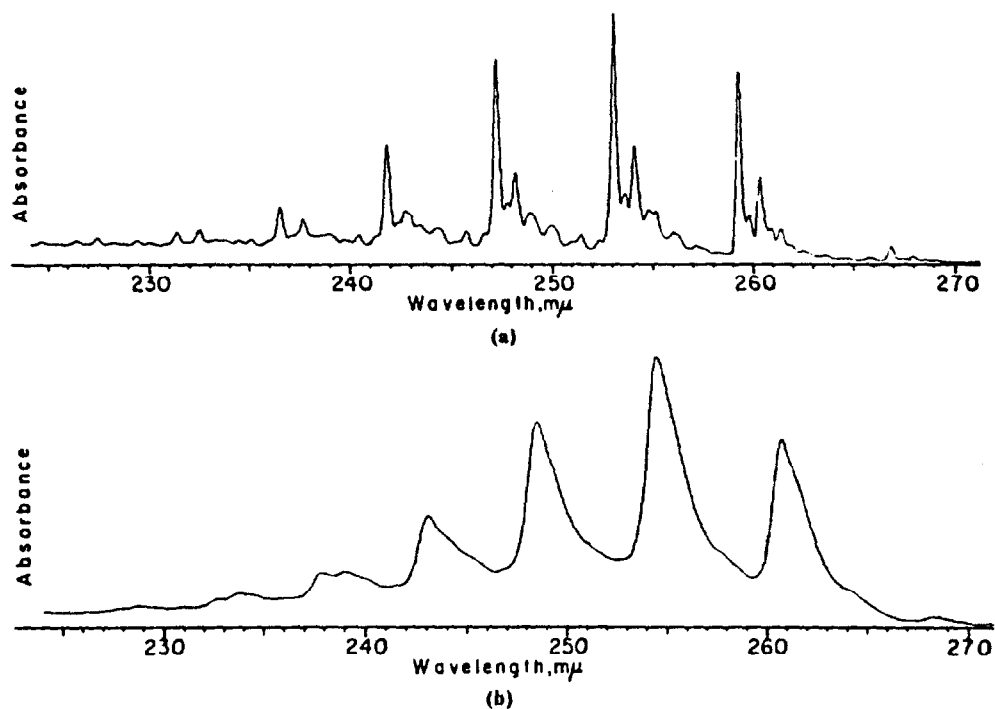

Fig 5 Ultraviolet Absorption Spectrum of Benzene
(a) vapor (b) ethanol solution

For organic materials, ultraviolet absorption spectra are substantially determined by the presence of functional groups. Identical functional groups in different molecules may not absorb at precisely the same wavelength due to different structural environments which modify the local electric field. The magnitude of the molar extinction coefficient (ϵ) for a particular absorption is directly proportional to the probability of occurrence of the particular electronic transition. Spectral features of some isolated chromophoric groups are presented in Table 2

Ultraviolet spectroscopy has great utility in the characterization of expls and related materials, and serves as a primary analytical tool for the quantitative determination of reactant composition and purity. Additionally, it can provide the principal method of monitoring expl kinetics and reaction mechanisms, since the high temps characteristic of expls are effective in creating electronic excitations

Time resolved ultraviolet emission spectroscopy of acetylene-oxygen expls has been used to compute free radical concns (Refs 30 & 35).

Comparison of emission spectra between 2100Å and 6500Å has shown only small differences in relative concns of excited species between low-pressure diffusion flames and expls, whereas during expls peak intensities may be as much as 100 times greater. The time dependence of the free-radical emission during expln indicates the formation sequence to be OH, CH, C₂, and evidence for the forbidden CO Cameron bands has been obtained. Similarly the ultraviolet absorption spectrum of the OH radical in acetylene-H₂-O₂ detonations has been measured in conjunction with the associated rarefaction waves (Ref 7). Analysis of the absorption spectrum has indicated average rotational temps greater than 3000°K during the initial 310 microseconds

Time resolved ultraviolet spectroscopy has also been applied to solid expls. Observations have been reported of the luminosity created by 13g Pentolite sphere expls in air, N₂ and O₂ (Ref 31). Partial identification of the spectral species has suggested a wide range of excitations in the three gases, from low energy forbidden O₂-band radiation to ionized N₂ radiation.

Table 2
Characteristics of Simple Chromophoric Groups

Chromophore	Example	λ_{\max} , m μ	ϵ_{\max}	Solvent	
$\text{C}=\text{C}$	Ethylene	171	15,530	Vapor	
	1-Octene	177	12,600	Heptane	
	— C \equiv C —	2-Octyne	178	10,000	Heptane
			196	ca 2,100	Heptane
			223	160	Heptane
$\text{C}=\text{O}$	Acetaldehyde	160	20,000	Vapor	
		180	10,000	Vapor	
		290	17	Hexane	
	Acetone	166	16,000	Vapor	
		189	900	Hexane	
		279	15	Hexane	
		208	32	Ethanol	
— CO ₂ H	Acetic acid	208	32	Ethanol	
— COCl	Acetyl chloride	220	100	Hexane	
— CONH ₂	Acetamide	178	9,500	Hexane	
		220	63	Water	
— CO ₂ R	Ethyl acetate	211	57	Ethanol	
— NO ₂	Nitromethane	201	5,000	Methanol	
		274	17	Methanol	
		270	17	Ethanol	
— ONO ₂	Butyl nitrate	220	14,500	Hexane	
— ONO	Butyl nitrite	356	87	Hexane	
		300	100	Ether	
— NO	Nitrosobutane	665	20	Ether	
$\text{C}=\text{N}$	neo-Pentylidene n-butylamine	235	100	Ethanol	
— C \equiv N	Acetonitrile	167	weak	Vapor	
— N ₃	Azidoacetic ester	285	20	Ethanol	
= N ₂	Diazomethane	ca 410	3	Vapor	
	Diazoacetic ester	249	10,050	Ethanol	
— N = N —	Azomethane	378	16	Ethanol	
		338	4	Ethanol	

Evidence has suggested that excitation derives from collisional activation of ambient gas with expl produced particulates

Chemical analysis of expl reaction products has been performed utilizing spectroscopic methods. A study of the thermal decomn of Tetrazene at 90° has demonstrated that substantially complete conversion to 5-aminotetrazole is effected (Ref 69). Spectroscopic evidence has indicated that this product is derived from both the side chain (guanyl azide) and the Tetrazole ring. Utilizing the unique-to-mercury absorption line at 2536.5Å, mercury (II) concn

in mercuric 5-nitrotetrazole has been determined with a precision of 0.1 to 0.6 percent (Ref 64). In the same work a technique for quantitative determination of the 5-nitrotetrazole anion was reported, using the absorption at 2570Å. Additional applications of ultraviolet spectrophotometry to expl composites are documented in Ref 65b

3) Visible Spectroscopy

Among the primary phenomena accompanying an expln, incendiary or pyrot display is the generation of visible light. For high temp re-

actions some of the thermal energy extends into the visible region (see Figs 2 & 3), while characteristic atomic or molecular emission lines and bands are superimposed on the thermal radiation spectrum to provide specific coloration. The spectral properties of pyrot materials were reviewed earlier (Vol 8, P504-R ff)

The early optical spectrum and airshock from a 500-ton TNT expln has been documented (Ref 22). Spectroscopic analysis has revealed that the expl light was produced largely by impurity radiation from sodium, calcium and cyanogen and by forbidden O_2 bands. The expected airshock radiation was not detected, presumably due to poor coupling between the airshock and luminosity front

The visible spectra of flares containing Mg as a fuel and sodium, potassium and rubidium nitrates as oxidizers have been examined for molecular emission from such species as diatomic alkali metals, magnesium-alkali metal diatomics and quasi-molecules such as Na-N₂ (Ref 59). Emission characteristics of the observed atomic species agree with prior observations, and new diatomic alkali metal emission bands have been identified as well as a new Na-Mg interaction

Investigations of flow phenomena associated with the muzzle flash of small caliber guns, have shown that gas temps, both inside and outside the bore, can be derived from spectroscopic analysis of the flash characteristics (Ref 51). Related effects describing the down-range ballistic impact flash from the perforation of thin Al plates by steel and Al fragment simulators are described in Ref 27. By comparison of the relative intensities of vibrational band structure in the A10 green system, an effective vibrational temp for the flash has been determined to be between 3400°K and 4100°K

Time integrated grating spectra from flames produced by Mg-Ba(NO₃)₂, Mg-NaNO₃, Mg-Ba(NO₃)₂-Sr(NO₃)₂-TFE, Al-NaClO₄-PVC, Al-KClO₄-PVC, Al-Sr(ClO₄)₂-PVC, B-Ba(ClO₄)₂-PVC, B-KClO₄-PVC, Mg-LiClO₄-PVC and Mg-NaClO₄ for various weight percentages have been measured (Ref 25). The absorption of visible light resulting from passage thru the smoke evolved during combustion was determined and absorption coefficients tabulated for the smokes as a function of compn and ambient pressures

Recent techniques for detailed mapping and elucidation of processes occurring in pyrotechnic flames have incorporated computer assisted analysis. Ref 66 discusses the implementation of computer automated high speed mapping techniques and optical scanning as applied to spectroscopic analysis of transient combustion and pyrot processes. The considerations involved in the further development of exptl hardware and software have also been discussed

Chemical analysis employing visible spectrophotometry is reported in Ref 67. Details of procedures for the identification and analysis of polynitroaromatic expl materials are presented, together with a discussion of structural property relationships to observed spectra

4) Infrared Spectroscopy

In contrast to the relatively few absorption lines and bands observed in the ultraviolet and visible regions, the infrared (IR) provides a multitude of transitions that can provide detailed structural information of molecular systems, particularly with respect to organic materials

There are two kinds of fundamental vibrations in molecules: stretching, in which the distance between two atoms varies while a fixed bond axis is maintained, and bending, in which the position of the atom changes relative to the original bond axis. The various vibrations of a bond occur at specific quantized frequencies so that upon absorption of photons of appropriate frequencies, the amplitudes of those vibrations are increased. A non-linear molecule containing n atoms has 3n-6 possible fundamental vibrational modes, additional (non-fundamental) absorption bands occurring as a result of overtones (harmonics) with greatly reduced intensity at 1/2, 1/3 . . . of the difference bands. The magnitude of the molar extinction coefficient in infrared spectroscopy varies from near zero to approximately 2000. The value is proportional to the square of the change in dipole moment of the vibrating molecule, stretching vibrations generally resulting in the strongest absorption

Fig 6 Normal Vibrational Modes of CO₂ and H₂O

Table 3
Characteristic Infrared Absorptions of Functional Groups

Group	Range μ	Intensity	Range, cm^{-1}
A. Hydrocarbon chromophore			
1. C-H STRETCHING			
a. Alkane	3.38-3.51	(m-s)	2962-2853
b. Alkene, monosubstituted (vinyl)	3.29-3.32	(m)	3040-3010
	and 3.23-3.25	(m)	3095-3075
Alkene, disubstituted, cis	3.29-3.32	(m)	3040-3010
Alkene, disubstituted, trans	3.29-3.32	(m)	3040-3010
Alkene, disubstituted, gem	3.23-3.25	(m)	3095-3075
Alkene, trisubstituted	3.29-3.32	(m)	3040-3010
c. Alkyne	~ 3.03	(s)	~ 3300
d. Aromatic	~ 3.30	(v)	~ 3030
2. C-H BENDING			
a. Alkane, C-H	~ 7.46	(w)	~ 1340
Alkane, $-\text{CH}_2-$	6.74-6.92	(m)	1485-1445
Alkane, $-\text{CH}_3$	6.80-7.00	(m)	1470-1430
	and 7.25-7.30	(s)	1380-1370
Alkane, gem-dimethyl	7.22-7.25	(s)	1385-1380
	and 7.30-7.33	(s)	1370-1365
Alkane, tert-butyl	7.17-7.22	(m)	1395-1385
	and ~ 7.33	(s)	~ 1365
b. Alkene, monosubstituted (vinyl)	10.05-10.15	(s)	995-985
	10.93-11.05	(s)	915-905
	and 7.04-7.09	(s)	1420-1410
Alkene, disubstituted, cis	~ 14.5	(s)	~ 690
Alkene, disubstituted, trans	10.31-10.42	(s)	970-960
	and 7.64-7.72	(m)	1310-1295
Alkene, disubstituted, gem	11.17-11.30	(s)	895-885
	and 7.04-7.09	(s)	1420-1410
Alkene, trisubstituted	11.90-12.66	(s)	840-790
c. Alkyne	~ 15.9	(s)	~ 630
d. Aromatic, substitution type: \ddagger			
five adjacent hydrogen atoms	~ 13.3	(v, s)	~ 750
	and ~ 14.3	(v, s)	~ 700
four adjacent hydrogen atoms	~ 13.3	(v, s)	~ 750
three adjacent hydrogen atoms	~ 12.8	(v, m)	~ 780
two adjacent hydrogen atoms	~ 12.0	(v, m)	~ 830
one hydrogen atom	~ 11.3	(v, w)	~ 880
3. C-C MULTIPLE BOND STRETCHING			
a. Alkene, nonconjugated	5.95-6.17	(v)	1680-1620
Alkene, monosubstituted (vinyl)	~ 6.08	(m)	~ 1645
Alkene, disubstituted, cis	~ 6.03	(m)	~ 1658
Alkene, disubstituted, trans	~ 5.97	(m)	~ 1675
Alkene, disubstituted, gem	~ 6.05	(m)	~ 1653

continued

Table 3 (continuation)

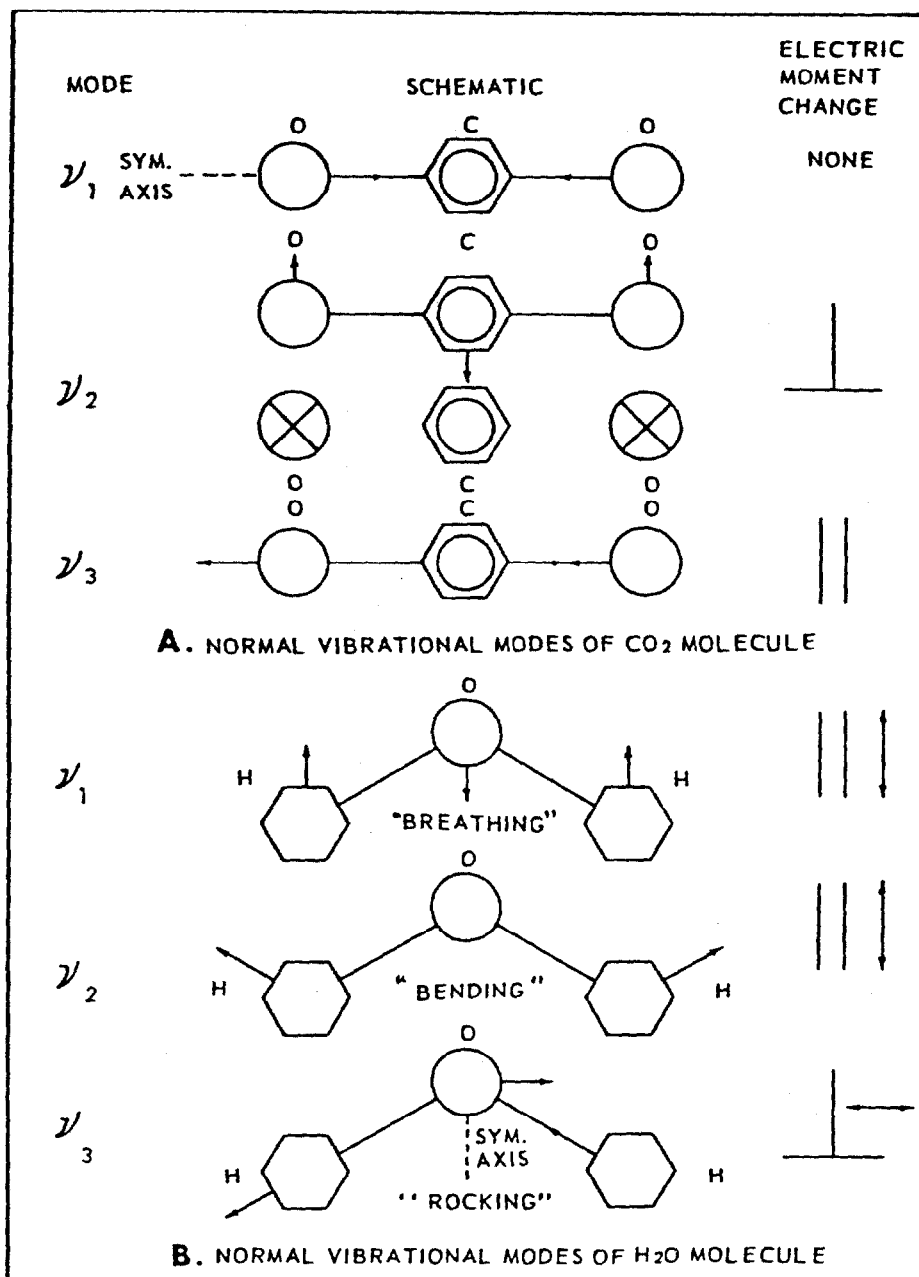
Group	Range μ	Intensity	Range cm^{-1}
Alkene, trisubstituted	~ 5.99	(m)	~ 1669
Alkene, tetrasubstituted	~ 5.99	(w)	~ 1669
Diene	~ 6.06	(w)	~ 1650
	and ~ 6.25	(w)	~ 1600
b. Alkyne, monosubstituted	4.67–4.76	(m)	2140–2100
Alkyne, disubstituted	4.42–4.57	(v, w)	2260–2190
c. Allene	~ 5.1	(m)	~ 1960
	and ~ 9.4	(m)	~ 1060
d. Aromatic	~ 6.25	(v)	~ 1600
	~ 6.33	(v)	~ 1580
	~ 6.67	(m)	~ 1500
	and ~ 6.90	(m)	~ 1450
B. Carbonyl chromophore			
1. KETONE STRETCHING VIBRATIONS			
a. Saturated, acyclic	5.80–5.87	(s)	1725–1705
b. Saturated, cyclic:			
6-membered ring (and higher)	5.80–5.87	(s)	1725–1705
5-membered ring	5.71–5.75	(s)	1750–1740
4-membered ring	~ 5.63	(s)	~ 1775
c. α, β -Unsaturated, acyclic	5.94–6.01	(s)	1685–1665
d. α, β -Unsaturated, cyclic:			
6-membered ring (and higher)	5.94–6.01	(s)	1685–1665
5-membered ring	5.80–5.85	(s)	1725–1708
e. $\alpha, \beta, \alpha', \beta'$ -Unsaturated, acyclic	5.99–6.01	(s)	1670–1663
f. Aryl	5.88–5.95	(s)	1700–1680
g. Diaryl	5.99–6.02	(s)	1670–1660
h. α -Diketones	5.78–5.85	(s)	1730–1710
i. β -Diketones (enolic)	6.10–6.50	(s)	1640–1540
j. 1,4-Quinones	5.92–6.02	(s)	1690–1660
k. Ketenes	~ 4.65	(s)	~ 2150
2. ALDEHYDES			
a. Carbonyl stretching vibrations			
Saturated, aliphatic	5.75–5.81	(s)	1740–1720
α, β Unsaturated, aliphatic	5.87–5.95	(s)	1705–1680
$\alpha, \beta, \gamma, \delta$ -Unsaturated, aliphatic	5.95–6.02	(s)	1680–1660
Aryl	5.83–5.90	(s)	1715–1695
b. C–H Stretching vibrations, two bands	3.45–3.55	(w)	2900–2820
	and 3.60–3.70	(w)	2775–2700
3. ESTER STRETCHING VIBRATIONS			
a. Saturated, acyclic	5.71–5.76	(s)	1750–1735
b. Saturated, cyclic:			
δ -lactones (and larger rings)	5.71–5.76	(s)	1750–1735
γ -lactones	5.62–5.68	(s)	1780–1760
β -lactones	~ 5.5	(s)	~ 1820
c. Unsaturated:			
vinyl ester type	5.56–5.65	(s)	1800–1770

continued

Table 3 (continuation)

Group	Range μ	Intensity	Range cm^{-1}
α, β -unsaturated and aryl	5.78–5.82	(s)	1730–1717
α, β -unsaturated δ -lactone	5.78–5.82	(s)	1730–1717
α, β -unsaturated γ -lactone	5.68–5.75	(s)	1760–1740
β, γ -unsaturated γ -lactone	~ 5.56	(s)	~ 1800
d. α -Ketoesters	5.70–5.75	(s)	1755–1740
e. β -Ketoesters (enolic)	~ 6.06	(s)	~ 1650
f. Carbonates	5.62–5.75	(s)	1780–1740
4. CARBOXYLIC ACIDS			
a. Carbonyl stretching vibrations:			
saturated aliphatic	5.80–5.88	(s)	1725–1700
α, β -unsaturated aliphatic	5.83–5.92	(s)	1715–1690
aryl	5.88–5.95	(s)	1700–1680
b. Hydroxyl stretching (bonded), several bands	3.70–4.00	(w)	2700–2500
c. Carboxylate anion stretching	6.21–6.45	(s)	1610–1550
	and 7.15–7.69	(s)	1400–1300
5. ANHYDRIDE STRETCHING VIBRATIONS			
a. Saturated, acyclic			
	5.41–5.56	(s)	1850–1800
	and 5.59–5.75	(s)	1790–1740
b. α, β -Unsaturated and aryl, acyclic	5.47–5.62	(s)	1830–1780
	and 5.65–5.81	(s)	1770–1720
c. Saturated, 5-membered ring	5.35–5.49	(s)	1870–1820
	and 5.56–5.71	(s)	1800–1750
d. α, β -Unsaturated, 5-membered ring	5.41–5.56	(s)	1850–1800
	and 5.47–5.62	(s)	1830–1780
6. ACYL HALIDE STRETCHING VIBRATIONS			
a. Acyl fluorides	~ 5.41	(s)	~ 1850
b. Acyl chlorides	~ 5.57	(s)	~ 1795
c. Acyl bromides	~ 5.53	(s)	~ 1810
d. α, β -Unsaturated and aryl	5.61–5.72	(s)	1780–1750
	and 5.72–5.82	(m)	1750–1720
e. COF_2	5.19	(s)	1928
f. COCl_2	5.47	(s)	1828
g. COBr_2	5.47	(s)	1828
7. AMIDES			
a. Carbonyl stretching vibrations:			
Primary, solid and concentrated solution	~ 6.06	(s)	~ 1650
Primary, dilute solution	~ 5.92	(s)	~ 1690
Secondary, solid and concentrated solution	5.95–6.14	(s)	1680–1630
Secondary, dilute solution	5.88–5.99	(s)	1700–1670
Tertiary, solid and all solutions	5.99–6.14	(s)	1670–1630
Cyclic, δ -lactams, dilute solution	~ 5.95	(s)	~ 1680
Cyclic, γ -lactams, dilute solution	~ 5.88	(s)	~ 1700
Cyclic, γ -lactams, fused to another ring, dilute solution	5.71–5.88	(s)	1750–1700
Cyclic, β -lactams, dilute solution	5.68–5.78	(s)	1760–1730
Cyclic, β -lactams, fused to another ring, dilute solution	5.62–5.65	(s)	1780–1770

continued

Table 3 (continuation)

Group	Range μ	Intensity	Range cm^{-1}
Ureas, acyclic	~ 6.02	(s)	~ 1660
Ureas, cyclic, 6-membered ring	~ 6.10	(s)	~ 1640
Ureas, cyclic, 5-membered ring	~ 5.81	(s)	~ 1720
Urethanes	5.75–5.92	(s)	1740–1690
Imides, acyclic	~ 5.85	(s)	~ 1710
	and ~ 5.88	(s)	~ 1700
Imides, cyclic, 6-membered ring	~ 5.85	(s)	~ 1710
	and ~ 5.88	(s)	~ 1700
Imides, cyclic, α, β -unsaturated, 6-membered ring	~ 5.78	(s)	~ 1730
	and ~ 5.99	(s)	~ 1670
Imides, cyclic, 5-membered ring	~ 5.65	(s)	~ 1770
	and ~ 5.88	(s)	~ 1700
Imides, cyclic, α, β -unsaturated, 5-membered ring	~ 5.59	(s)	~ 1790
	and ~ 5.85	(s)	~ 1710
b. N–H Stretching vibrations			
Primary, free; two bands	~ 2.86	(m)	~ 3500
	and ~ 2.94	(m)	~ 3400
Primary, bonded; two bands	~ 2.99	(m)	~ 3350
	and ~ 3.15	(m)	~ 3180
Secondary, free; one band	~ 2.92	(m)	~ 3430
Secondary, bonded; one band	3.0 –3.2	(m)	3320–3140
c. N–H Bending vibrations:			
Primary amides, dilute solution	6.17–6.29	(s)	1620–1590
Secondary amides, dilute solution	6.45–6.62	(s)	1550–1510
C. Miscellaneous chromophoric groups			
1. ALCOHOLS AND PHENOLS			
a. O–H Stretching vibrations:			
Free O–H	2.74–2.79	(v, sh)	3650–3590
Intermolecularly hydrogen bonded (change on dilution)			
single bridge compounds	2.82–2.90	(v, sh)	3550–3450
polymeric association	2.94–3.13	(s, b)	3400–3200
Intramolecularly hydrogen bonded (no change on dilution)			
single bridge compounds	2.80–2.90	(v, sh)	3570–3450
chelate compounds	3.1 –4.0	(w, b)	3200–2500
b. O–H Bending and C–O stretching vibrations			
Primary alcohols	~ 9.5	(s)	~ 1050
	and 7.4 –7.9	(s)	1350–1260
Secondary alcohols	~ 9.1	(s)	~ 1100
	and 7.4 –7.9	(s)	1350–1260
Tertiary alcohols	~ 8.7	(s)	~ 1150
	and 7.1 –7.6	(s)	1410–1310
Phenols	~ 8.3	(s)	1200
	and 7.1 –7.6	(s)	1410–1310

continued

Table 3 (continuation)

Group	Range μ	Intensity	Range cm^{-1}
2. AMINES			
a. N-H Stretching vibrations:			
Primary, free; two bands	~ 2.86	(m)	~ 3500
	and ~ 2.94	(m)	~ 3400
Secondary, free; one band	2.86-3.02	(m)	3500-3310
Imines (=N-H); one band	2.94-3.03	(m)	3400-3300
Amine salts	3.2-3.3	(m)	3130-3030
b. N-H Bending vibrations:			
Primary	6.06-6.29	(s-m)	1650-1590
Secondary	6.06-6.45	(w)	1650-1550
Amine salts	6.25-6.35	(s)	1600-1575
	and ~ 6.67	(s)	~ 1500
c. C-N Vibrations:			
Aromatic, primary	7.46-8.00	(s)	1340-1250
Aromatic, secondary	7.41-7.81	(s)	1350-1280
Aromatic, tertiary	7.36-7.64	(s)	1360-1310
Aliphatic	8.2-9.8	(w)	1220-1020
	and ~ 7.1	(w)	~ 1410
3. UNSATURATED NITROGEN COMPOUNDS			
a. C \equiv N Stretching vibrations:			
Alkyl nitriles	4.42-4.46	(m)	2260-2240
α,β -Unsaturated alkyl nitriles	4.47-4.51	(m)	2235-2215
Aryl nitriles	4.46-4.50	(m)	2240-2220
Isocyanates	4.40-4.46	(m)	2275-2240
Isocyanides	4.50-4.83	(m)	2220-2070
b. >C=N- Stretching vibrations (imines, oximes)			
Alkyl compounds	5.92-6.10	(v)	1690-1640
α,β -Unsaturated compounds	6.02-6.14	(v)	1660-1630
c. -N=N- Stretching vibrations, azo compounds			
	6.14-6.35	(v)	1630-1575
d. -N=C=N- Stretching vibrations, diimides			
	4.64-4.70	(s)	2155-2130
e. -N ₃ Stretching vibrations, azides			
	4.63-4.72	(s)	2160-2120
	and 7.46-8.48	(w)	1340-1180
f. C-NO ₂ , Nitro compounds:			
aromatic	6.37-6.67	(s)	1570-1500
	and 7.30-7.70	(s)	1370-1300
aliphatic	6.37-6.45	(s)	1570-1550
	and 7.25-7.30	(s)	1380-1370
g. O-NO ₂ , Nitrates			
	6.06-6.25	(s)	1650-1600
	and 7.70-8.00	(s)	1300-1250
h. C-NO, Nitroso compounds			
	6.25-6.67	(s)	1600-1500
I. O-NO, Nitrites			
	5.95-6.06	(s)	1680-1650
	and 6.15-6.21	(s)	1625-1610
4. HALOGEN COMPOUNDS, C-X STRETCHING VIBRATIONS			
a. C-F	7.1-10.0	(s)	1400-1000
b. C-Cl	12.5-16.6	(s)	800-600
c. C-Br	16.6-20.0	(s)	600-500
d. C-I	~ 20	(s)	~ 500

continued

Table 3 (continuation)

Group	Range μ	Intensity	Range cm^{-1}
5. SULFUR COMPOUNDS			
a. S-H Stretching vibrations	3.85-3.92	(w)	2600-2550
b. C=S Stretching vibrations	8.33-9.52	(s)	1200-1050
c. S=O Stretching vibrations:			
sulfoxides	9.35-9.71	(s)	1070-1030
sulfones	8.62-8.77	(s)	1160-1140
and	7.41-7.69	(s)	1350-1300
sulfites	8.13-8.70	(s)	1230-1150
and	7.00-7.41	(s)	1430-1350
sulfonyl chlorides	8.44-8.59	(s)	1185-1165
and	7.30-7.46	(s)	1370-1340
sulfonamides	8.48-8.77	(s)	1180-1140
and	7.41-7.69	(s)	1350-1300
sulfonic acids	8.27-8.70	(s)	1210-1150
and	9.43-9.71	(s)	1060-1030
and	~ 15.4	(s)	~ 650

Table 3 contains a list of the easily interpreted absorption bands of the more common functional groups found in organic compds

A compilation of infrared spectra of ingredients of propellants and explosives is available (Ref 13) which documents infrared spectral features in the 2-15 micron range for more than 175 substances. Additional tabulations of the frequencies of the strong IR absorption bands of 46 derivatives of di- and tri-nitrobenzene, together with structural-spectral interpretation suitable for identification purposes is presented in Ref 10. A comprehensive survey of the IR spectra of inorganic nitrates and analytical techniques for the determination of ordnance-related nitrates is presented in Ref 32. The applications of IR spectroscopy to identification and quantitative analysis have also been reviewed (Ref 37)

The uses of IR spectra in identification, classification and mechanistic studies have been well documented. Tests for the identification of plastics utilized in Naval ordnance weaponry are discussed in Ref 21. Correlations between polymeric structure and ablative properties using IR spectroscopy have been obtained by monitoring changes in functional group absorption properties (Ref 12). The application of IR spectroscopy to the detection of more than 40 of the most common constituents of primers, tracers, igniters, incendiaries,

boosters and delay compositions has been discussed, and spectral curves in the 2.5-50 micron range prepared (Ref 39)

Considerable attention has been directed toward development of IR spectral analytical techniques for HMX and related compds. Ref 56 discusses the analysis of alpha, gamma and delta HMX in beta HMX, and presents a detailed literature survey of the properties of HMX polymorphs, and hazard aspects connected with the transitions between the stable beta form and its polymorphs. Spectrophotometric analysis of HMX in PBX 9404 (a plastic bonded expl) is documented in Ref 53. IR techniques have also been useful in the determination of the effects of low level gamma radiation on the thermal sensitivity of HMX, RDX and HMX-RDX mixts (Ref 61)

Inorganic expl materials have also proven to be amenable to IR spectroscopic analysis. An IR spectrophotometric analysis method for carbon monoxide, carbon dioxide, nitric oxide, nitrous oxide and nitrogen dioxide produced in vacuum stability tests of expls stored together with polymeric materials has been developed (Ref 60). Structural properties, as elucidated by IR absorption, of a variety of new perfluorinated and halofluorinated covalent perchlorates are reported in Ref 42. Characterization of the products of the pyrot reaction of silicon and red lead in oxygen

and nitrogen has also been accomplished (Ref 68)

The versatility of IR spectroscopic methods as applied to kinetic and mechanistic studies has been evident from studies of slow decomp of some model expl compds (Ref 34). Quantitative data from IR spectrograms of the N-aryl-N'-tosyloxydi-imide N-oxide system thermal decompn have been used to construct decompn versus time curves. These data have been used to compute kinetic parameters, activation energies and to formulate a consistent mechanism for the process

Structure-property correlations in primary expls have been addressed via IR spectroscopy (Ref 55). The time for deflagration to detonation as a function of chemical structure for the compd methylnitrotetra-pyrrole was investigated and the presence of the nitro group confirmed by IR analysis

Conventional IR spectroscopic techniques have been adapted to studies of the expln limits of simple difluoroamino compds (Ref 17). Analytic data on the effects of NO addition to decompn and expln behavior of 1,2-DP, 2,2-DP and 1-BA permitted identification of the homogeneous and heterogeneous decompn mechanisms of 1,2-DP and 2,2-DP, respectively

Results of a comprehensive study of the absolute spectral radiance of the infrared emissions from methane-air explns have been reported (Ref 44). The spectral growth of these expanding flames was recorded with a time resolution of one msec in the spectral range 1.7–5.0 microns. Time resolved spectra were obtained as a function of stoichiometry, nitrogen dilution and Halon dilution. Similar data are also available for coal dust-air explns. Additional applications of rapid scan IR spectroscopy are discussed in Ref 50. In this work, flare spectra (Mk-45, LUU-2B and LUU-2B/B) in the 1.7–4.7 and 9–14 micron regions were studied. The Mk-45 and LUU-2B/B showed similar spectral character with Na and CO₂ emissions superimposed on a gray body continuum, while LUU-2B flares demonstrated variable emittance properties

A unique application of IR spectroscopy to expl technology is the measurement of auroral far IR emissions (Ref 43). In conjunction with the High Altitude Effects Simulation (HAES)

program, efforts were directed toward obtaining information on the reaction of the upper atmosphere to nuclear explns. The rocket borne high resolution interferometer spectrometer was designed to provide data relating precipitating particle fluxes with infrared auroral properties for natural and disturbed conditions

5) *Additional Spectroscopic Techniques*

In addition to conventional optical spectroscopy, a number of other spectroscopic techniques have been applied to studies of expls and propnlts. Mass spectrometry applications to analysis of expl materials and combustion products, as well as characterization of reaction mechanisms are described in Refs 20, 23, 36, 38 & 46. A detailed discussion of mass spectrometry has previously been presented (Vol 8, M19-L ff)

Nuclear magnetic resonance spectroscopy (NMR) provides a useful tool for structural and mechanistic studies of high energy materials. The theory of NMR is based on the possession of angular momentum (mechanical spin) by certain isotopes. Since an electric charge is associated with the nucleus, the spin gives rise to a magnetic field with its axis coincident with that of the spin. In a static external magnetic field, only a limited number of orientations are allowed. Absorption of electromagnetic energy can induce transitions among the spin states, with the precessional frequency of the nuclear spin being equal to the frequency of the excitation radiation. Analysis of NMR can provide detailed structural and configurational information about complex molecular species. Exptl techniques and interpretation methodology for NMR spectroscopy have been extensively reviewed (Ref 48). NMR spectroscopy has been utilized in fundamental mechanistic studies of the nitration of toluene to 2,4,6-trinitrotoluene (TNT) and benzene to 1,3,5-trinitrobenzene (TNB) (Ref 54). The configuration of Tx-08-Dr (PEX) has been elucidated using NMR techniques (Ref 47)

The use of NMR spectroscopy for the detection of expls hidden in airline baggage has been reported (Ref 57). Most common expls (except BlkPdr) can be detected, and the NMR signatures from expls can be separated from responses of adjacent materials

X-ray photoelectron spectroscopy (XPS) has been applied to the study of surface properties of expl solids and pyrot materials. PicArSn has undertaken a wide ranging study of XPS which has led to new fundamental knowledge of the electronic structure, reaction mechanisms and microscopic processes involved in the rapid decomn of expls, proplnts and related compds (Ref 49). Investigations of surfaces and thin films of small band-gap inorganic azides using XPS have shown that the surfaces are stoichiometrically deficient in nitrogen, and that carbon and oxygen contamination predominates (Ref 58). This lack of surface stoichiometry is important for electrical properties involving the surface (eg, electric field initiation of detonation). Conversely, surface films tend to provide protective coatings, so that 20-year old Pb azide does not show significant bulk decomn. Passive surface reactivation by exposure to hydrazoic acid has also been demonstrated using XPS techniques. Additional surface characterization studies of pyrot materials using XPS have addressed components of thermal batteries including Fe powder, Ca chromate, Ni oxide and K perchlorate (Ref 65a)

Laser systems have been applied to spectroscopic studies of expls (Ref 40). A novel expl vapor detector, based on photoacoustic measurements, has been used to characterize absorption coefficients of expl reaction products (Ref 63). Acoustic spectra from underwater TNT explns have also been measured and analyzed with respect to refracted pulse behavior (Ref 15)

Measurements of the emission of gamma rays from radionuclides provides a highly sensitive technique for elemental analysis of products from nuclear explns. Extensive computer programs have been developed for the analysis of components of gamma pulse heights from mixts of radioactive debris produced by underwater nuclear detonations (Ref 18). Measurements of fallout hazards and fission product distributions using gamma ray spectroscopy have shown reasonably good correlation with calcd properties (Refs 11, 24, 33 & 45). Gamma ray spectroscopy has also been applied to studies of solid proplnts (Ref 41). Activation with thermal neutrons followed by measurements of the emitted gamma ray spectrum permits non-destructive analysis of solid proplnt samples for trace impurities of Na and K

Written by S. A. GREENBERG

Refs: (Reports identified by AD numbers are available from Defense Documentation Center, Cameron Station, Alexandria, VA 22314)

- 1) H.E. White, "Introduction to Atomic Spectra" (1934)
- 2) G. Herzberg, "Atomic Spectra and Atomic Structure", 2nd ed (1944)
- 3) G. Herzberg, "Molecular Spectra and Molecular Structure", Vol 2, "Infrared and Raman Spectra of Polyatomic Molecules" (1946)
- 4) G. Herzberg, "Molecular Spectra and Molecular Structure, Vol 1, Spectra of Diatomic Molecules" (1950)
- 5) J.P. Phillips, H. Feuer & B.S. Thyagarajan, "Organic Electronic Spectral Data", J. Wiley & Sons, NY (1956-continuing)
- 6) G.L. Clark, ed, "Encyclopedia of Spectroscopy", Reinhold, NY (1960)
- 7) H. Miyama & P. Kydd, "Expansion Waves in Gaseous Detonations", **NONR-1866(36)** (1961), (AD 252-662)
- 8) G.M. Barrow, "Introduction to Molecular Spectroscopy" (1962)
- 9) G.W. King, "Spectroscopy and Molecular Structure" (1964)
- 10) T.N. Hall & J.P. Haberman, "Principal Absorption Bands of Some Derivatives of 1,3-Dinitrobenzene and 1,3,5-Trinitrobenzene", **NOLTR-64-62** (1964), (AD 442 908/ST)
- 11) P. Brown & J.L. Brown, "Fallout Hazard Determination by Fireball Spectroscopy", Report on Operation Sunbeam, Shots Little Feller I, II (1965), (AD 458 238/3ST)
- 12) G.J. Fleming, "Correlation of Polymeric Structure to Ablative Properties", **NOLTR 65-50** (1965), (AD 467 049)
- 13) F. Pristera & W.E. Fredericks, "Compilation of Infrared Spectra of Ingredients of Propellants and Explosives", **USGDR6617** (1965), (AD 636 181)
- 14) C.N. Banwell, "Fundamentals of Molecular Spectroscopy" (1966)
- 15) M.A. Genau, "Underwater Shock Frequency Spectrum Analysis. V. Spectra of Refracted Pulses Compared with Isovelocity Shock Waves", **NOLTR-66-4** (1966), (AD 632 529)
- 16) G. Herzberg, "Molecular Spectra and Molecular Structure", Vol 3, "Electronic Spectra and Electronic Structure of Polyatomic Molecules" (1966)
- 17) G. von Elbe, J.B. Levy & G. White, "A Study of the Explosion Limits of Simple Difluoroamino Compounds", **NONR-4065(00)** (1966), (AD 374 015/6ST)
- 18) J.F. Pestaner & D.L. Love, "Computer Program for Identifying and Measuring Components in a Mixture of Gamma-Emitting Radionuclides", **USNRDL-TR-67-46** (1967), (AD 651 659)
- 19) G.J. Fleming, "Constructive Thermal Degradation of Epoxide

- Resins Cured with Several Novel Bridged Diels-Alder Anhydride Adducts", **NOLTR-67-40** (1967), (AD 654 391) 20) F. Daeublin, "Mass Spectrometric Analysis of Explosive Materials, Particularly Determining Their Characteristic Spectra", **ISL-T-31/67** (1967)
- 21) S.B. Knapp & J.A. Arne, "Identification of Plastics Used in Naval Ordnance", **OE/K-67-83** (1967), (AD 658 536) 22) L. Rudlin, J.G. Connor & J. Wisotski, "The Early Optical Spectrum and Airshock from a 500-Ton TNT Explosion", **NOLTR-67-94** (1967), (AD 662 404)
- 23) S. Bulusu, J.R. Autera & R.J. Graybush, "Mechanisms of Thermal Decomposition of HMX", Proc 1968 ArmySciConf (UCRD), Vol 2, p 423, West Point (1968), (AD 837 173/4ST)
- 24) J.H. Norman, P. Winchell & H.G. Staley, "Cloud Chemistry of Fallout Formation", **GA-8472** (1968), (AD 832 727/2ST)
- 25) R.M. Blunt, "Study Spectra of Metal-Oxidant Combinations", **DRI-3976-6803-F** (1968), (AD 673 976) 26) W.L. Ripley & C.A. Lipscomb, "Preliminary Investigation of the Reactivity of Lead Dioxide", **NAD-CR-RDTR-114** (1968)
- 27) J.B. Abernathy, "Ballistic Impact Flash", **GAW/MC/68-1** (1968), (AD 672 973)
- 28) E.L. Grove & J.F. Ribich, "Investigation of Chemical Species and Temperatures Present in Pyrotechnic Flames", **IITRI-U6044-11** (1968), (AD 841 032/6ST) 29) A.B. Striganov & N.S. Sventitskii, "Tables of Spectral Lines of Neutral and Ionized Atoms" (1968) 30) R.J. Oldman, W.B. Norris & H.P. Broida, "Time Resolved Emission Spectroscopy in Acetylene-Oxygen Explosions", **TR-33** (1969), (AD 714 730)
- 31) K.W. Reed & L. Rudlin, "Optical Spectra Produced by 13-gm Pentolite Spheres in Several Gases at Atmospheric Pressure", **NOLTR-69-37** (1969), (AD 689 354) 32) D.E. Chasan & G. Norwitz, "Application of Infrared Spectroscopy to the Analysis of Inorganic Nitrates", (1969), (AD 687 274) 33) T. Mamuro et al, "Studies on Fallout Particles. VI", *NihonGenshiryoku-Gakkaishi*(Japan) **8**, 309 (1969) 34) C.R. Downs, "Kinetics and Mechanisms of the Slow Decomposition of Some Model Explosive Compounds", **GAW/ME/69-3** (1969), (AD 856 - 714/1ST) 35) R.J. Oldman, W.B. Norris & H.P. Broida, "Time Resolved Emission Spectroscopy in Explosions", *CombustFlame* **14** (1), 61 (1970) 36) C. Riboudo, S. Semel & E.R. Blosser, "Research in Trace Analysis of Ultrapure Explosives. Part II. Spark Source Mass Spectrographic Analysis of Azides", **PATR 4014** (1970), (AD 707 934) 37) R.T.M. Fraser, "Analysis in the Near Infrared", **ERDE-TN-27** (1971), (AD 737 255) 38) R.P. Murman, T.F. Jenkins & P.C. Leggett, "Composition and Mass Spectra of Impurities in Military Grade TNT Vapor", **CRREL-SR-158** (1971), (AD 725 474)
- 39) D.E. Chasan & G. Norwitz, "Qualitative Analysis of Primers, Tracers, Igniters, Incendiaries, Boosters and Delay Compositions on a Micro Scale by the Use of Infrared Spectroscopy", **FA-T71-6-1** (1971), (AD 729 337)
- 40) P. DeMontgolfier, "Laser Induced Gas Breakdown Spectroscopic and Chemical Studies", **NASA-CR-121646, WIS-TCI-442X** (1971)
- 41) W.H. Barber, O.H. Dengel, R.H. Vogt & C.V. Strain, "Activation Analysis of Sodium and Potassium in Solid Propellants", *NuclTechnol* **12**, 381 (1971) 42) C.J. Schack, "Organic Perchlorates", **R-1019** (1972), (AD902 549/5ST)
- 43) C.K. Hinrichs, "Measurements of Auroral Emissions With a High Resolution Interferometer Spectrophotometer (HIRIS)", **SRI-EGU-TN-1928-A2** (1973), (AD 762 013) 44) M. Hertzberg et al, "The Spectral Growth of Expanding Flames: the Infrared Radiance of Methane-Air Ignitions and Coal-Dust-Air", **BuMines-RI-7779** (1973) 45) C.F. Smith, "Utilization of the Noble Gases in Studies of Underground Nuclear Detonations", **CONF-730915-6** (1973) 46) W.F. O'Reilly et al, "Exploratory Analysis of Vapor Impurities from TNT, RDX and Composition B", **CRREL-SR-194** (1973), (AD 769 731/1) 47) G.L. Clink, "NMR Analysis of RX-08-DR (PEX)", **MHSMP-74-5-K** (1973) 48) J.W. Robinson, ed, "Handbook of Spectroscopy", CRC Press, Cleveland (1974) 49) J. Sharma et al, "X-ray Photoelectron Spectroscopy of Explosive Solids", (1974), (AD 785 678/4SL) 50) C.E. Dinnerman, "Capabilities in Infrared Rapid Scan Spectroscopy With Preliminary Flare Spectra", **NAD-CR-RDTR-268** (1974), (AD 921 141/8ST)
- 51) G.A. Schroeder & G. Klingenberg, "Investigation of Flow Phenomena Associated With the Muzzle Flash of Small Caliber Guns", **ABF-E-2/74** (1974) 52) R.D. Sacks & J.A. Holcombe, "Radiative and Electrical Properties of Exploding Silver Wires", *JApplSpect* **28** (6), 518 (1974)

- 53) C.S. MacDougall & K.K. Bellamy, "Spectrophotometric Determination of HMX in PBX 9404", **MHSMP-75-24Q** (1975) 54) G.A. Olah, "High Energy Nitrogen Compounds", (1975), (AD A043 090/OST) 55) J.M. Guimont et al, "Structure-Property Correlations in Primary Explosives", **SRI-TPR-75-2** (1975) 56) H.L. Barreveld, "The Analysis of Alpha, Gamma and Delta HMX in Beta HMX", **TL-1975-17** (1975), (AD A027 090/OST) 57) W.L. Rollwitz, J.D. King & S.D. Shaw, "Determining the Potential of Radio-frequency Resonance Absorption Detection of Explosives Hidden in Airline Baggage", **SWRI-15-4225-F** (1975), (AD A022 111/9ST) 58) P. DiBona, D.A. Wiegand & J. Sharma, "Studies of Surfaces and Thin Films of Small Band Gap Inorganic Azides", **JVacSciTech** **13** (1), (1976) 59) H.A. Webster, III, "Alkali Metal Emitters. II. Identification of Diatomic Features", **NWSC-CR/RDTR-30** (1976), (AD A026 550/4ST) 60) H.L. Barreveld, "Infrared Spectrophotometric Analysis of Gases Produced in Vacuum Stability Tests of Gunpowders and Explosives", **TL-1976-9, TDCK-68047** (1976) 61) L. Avrami & H.J. Jackson, "Effect of Long Term Low-Level Gamma Radiation on Thermal Sensitivity of RDX/HMX Mixtures", **PATR 4964** (1976), (AD A032 959/9ST) 62) A.L. Johnson, A.L. Furno & J.M. Kuchta, "Infrared Spectral Radiances and Explosion Properties of Inhibited Methane-Air Flames", **BuMines-RI-8246** (1977) 63) J. Gebwachs, "Laser Photoacoustic Detection of Explosive Vapors", **SPIE SemProc** **108**, Opt in Secur and Law Enf, 10 (1977) 64) D.J. Glover, "Analysis of Mercuric 5-Nitrotetrazole", **NSWC/WOL/TR-77-71** (1977), (AD A044 844/9ST) 65a) W.E. Swartz, Jr, "Surface Analysis of Pyrotechnic Material", **GEPP-324** (1977) 65b) J.E. Harrar, "General Chemistry Division Quarterly Report", **UCID-15644-77-3** (1977) 66) M.B. Denton, "Investigating Mapping Techniques for Elucidating Processes Occurring in Pyrotechnic Flames and Their Flame Analogs", **Final Report Contract N00019-76-C-0510** (1977) 67) D.J. Glover & E.G. Kayser, "Quantitative Spectrophotometric Analysis of Polynitroaromatic Compounds by Reaction with Ethylenediamine", **NOLTR-67-175** (1977) 68) S.S. Al-Kazraji & G.J. Rees, "Pyrotechnic Reaction of Silicon and Red Lead", **Comb&Flame** **31** (2), 105 (1978) 69) R. Bird & A.J. Power, "Thermal Decomposition of Tetrazine at 90°C", **MRL-R-710** (1978), (AD A056 265/2ST)
- Spence Powders.** Spence patented expls contg 54 to 62% K chlorate together with saltpeter, sawdust, powdered charcoal (or coal), and wheat flour
Ref: Daniel (1902), 735
- Spent Acid.** See under "Nitration" in Vol 8, N45-R to N48-L
- Speziatsprengelatine** (Swiss). A name given by Stettbacher to low-freezing, powerful Dynamites manufd at Isleton and used in the construction of the Jungfrau tunnels. Essentially, these expls were based on Blasting Gelatin in which part of the NG was replaced by aromatic nitrocompds. One such expl had a d of 1.58g/cc and was a reddish-yellow, rubber-like material
Ref: Naoúm, Expls (1927), 113
- Sphere Test.** A metal acceleration test for measuring the relative performance of expls (*Ref* 1). Kury et al found the "cylinder test" to be more versatile (*Ref* 2)
Refs: 1) M.L. Wilkins, **UCRL-7797** (1964) 2) J.W. Kury et al, "Metal Acceleration by Chemical Explosives", 4th ONR Symp Deton (1965), 3-13
- SPHF.** Acronym for "shock-pass-heat filter" method for studying deflagration-to-detonation transitions. It is based on the fact that thin plates of inert material (steel, glass) are able to interrupt a detonation wave and convert it to a deflagration, thus requiring detonation to be reformed from deflagration on the opposite side of the plate if detonation is to continue beyond the plate
Refs: 1) Cook (1958), 83-89 & 187-194 2) M.A. Cook et al, **JAppPhys** **30**, 1579-84 (1959) & **CA** **54**, 1851 (1960)

Spigot Mortar. A mortar which propels a warhead larger than the bore of the mortar by means of a closed tube (spigot) attached to the warhead and extending into the mortar. The force of the propellant within the mortar acts upon the tube, thus propelling the warhead toward the target
 Ref: J. Quick, "Dictionary of Weapons and Military Terms", McGraw-Hill, NY (1973), 415

Spinning Detonation. Detonation waves travel usually at a constant velocity determined by the chemical energy released in detonation, the rate at which this energy is released, the density of the expl, and the charge diameter. In certain gaseous expls, detonation has been observed to propagate in a helical path, and this type is referred to as *spinning* or *helical* detonation
 Refs: 1) R.E. Duff & H.T. Knight, JChemPhys **20**, 1493-95 (1952) & CA **46**, 11688 (1952)
 2) J.A. Fay, JChemPhys **20**, 942-50 (1952) & CA **47**, 1931 (1953) 3) Cook (1958), 44, 59 & 143 4) M.F. Zimmer, "Spin Detonation in Nitroglycerin", Paper 65-17, Spring Mtg Western States Section Combustion Institute, Stanford Univ, Palo Alto, Calif (April 1964)

Spiralit. A propellant patented in 1898 by M. Thorn and manufd by Explosivstoff-Werke Spiralit Gesellschaft, Hamburg. It consisted of sheet NC, surface treated with a moderant, and compressed together to a thickness of as many as 40 sheets
 Ref: Daniel (1902), 735

Spirodihydantoin and Derivative

Spirodihydantoin (Bis-[2,5-dioxoimidazolidine]-spiran-(4,4') or Dihydantoin-spiran-(5,5'))

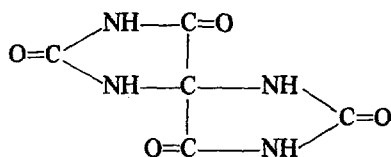

mw 184.11; crysts; N 30.43%. Sol in hot w.
 Prepn is by a Minsky et al (Ref 3, p 29) modified

Biltz et al method (Ref 2) in which alloxan monohydrate is heated (80-90°) with anhydrous urea followed by bubbling dry HCl gas thru the mixt. The reaction is then drowned in w, cooled, filtered and recrystd from boiling w. Yield is 61.9% of theory. Spirodihydantoin is the parent compd of Dinitrospirodihydantoin (see below)

Dinitrospirodihydantoin

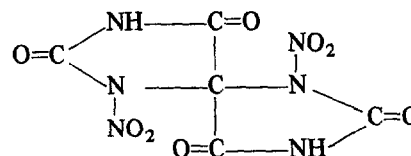

mw 274; cryst; N 30.65% (of which 10.22% is nitramine N); OB to CO₂ -29.20%; OB to CO, H₂O +11.7%; mp (decompn about 275°). Sol in ethanol, methanol, eth, nitromethane, amm hydroxide and w; insol in aromatic hydrocarbons and petr eth. Prepn is by addn of 15g of spirohydantoin to a stirred mixt consisting of 45g of phosphoric anhydride and 150cc of anhyd nitric acid at 40°. A reaction temp of 50° is then maintained for 1 hr. The soln is then cooled to 0° and drowned in 150g of crushed ice. The pptd product is filtered, washed with ice w and air dried. Yield is 87.8% of theory (Ref 3, p 30)

Dinitrospirodihydantoin is an expl which is less brisant, less stable and more sensitive to impact than TNT. Its properties, as detd at PicArsn (Ref 3, p 1), are as follows:

Brisance. 35.8g sand crushed (TNT=48.0g); a min detong charge of 0.100g Tetryl required
Explosion Temp. 245° (PETN=225°)

Heat of Combustion. 1474cal/g

100° Heat Test. Loss in wt, first 48 hrs, 0.49%; second 48 hrs, 0.43%; no expln in 100 hrs

Impact Sensitivity. PicArsn app with 2kg wt, 5" (PETN=6"); BuMines app, 13cm (PETN=17cm)

Vacuum Stability (90°). 0.99cc gas evolved by 1 g in 40 hrs (PETN=0.5cc)

When heated on a spatula it decomp leaving a large residue. It is incompatible with NC (Ref 3, p 15)

Refs: 1) Beil **26**, 159 & (314); not found for Dinitrospirodihydantoin 2) H. Biltz et al,

Ann 413, 78-82 (1917) & CA 11, 2200 (1917)
 3) I. Minsky et al, "Oxidizers for Solid Propellants", PAMR 16 (1952) 1, 15, 29, 30 & Table I

Spitback Fuze. A fuze located in the nose of a shaped charge munition. When initiated by impact it produces a detonation which is directed toward the base element which detonates the main expl charge. The combination of point impact fuze and base element is referred to as a *point initiating base detonating (PIBD)* fusing system

Ref: Anon, OrdnTechTerm (1962), 134-R

Spitback Tube. As pertains to shaped charge ammo - a tube attached to the truncated apex of a liner, ordinarily extending thru the expl charge. Thru this tube the detonating impulse is transmitted from the point of initiation to a detonator at the base of the expl charge

Ref: Anon, OrdnTechTerm (1962), 285-R

SPIW Flechette. Deriving from the *Salvo* project (qv), the SPIW (Special Purpose Individual Weapon) project was launched late in 1962. SPIW, like *Salvo*, was a US concept and was based on the replacement of the conventional projectile by one embodying a "flechette". Although the project itself dates from 1962, Aircraft Armaments Inc. (AAI) had tried an exptl single flechette as early as 1959. This had been fired in a modified Model 70 Winchester rifle, having a smooth-bore barrel and muzzle stripper. Prior to this, in 1957, AAI had produced "shotshell" multiple flechettes based on 12 gauge shotgun cartridges

Flechette ammo, as the name implies, was ammo in which a dart or arrow took the place of the conventional bullet. The flechette was of small diameter and wt, and was designed to be fired at very high velocity. At shortish ranges the combination of projectile length and wt and high velocity, gave the flechette a wound effect of a very high order, the flechette being unstable and tumbling upon impact. The flechette was intended, as far as the single flechette cartridge was concerned, to be fired at high rates of fire, controlled as to length of burst by an automatic

setting on the weapon. The flechette therefore satisfied one of the original *Salvo* requirements by giving projectile dispersion at the target. It was appreciated, however, that flechette cartridges were not "maids-of-all-work" and that conventional ammo would be required to meet some infantry needs

In fact, and in spite of its early promise, the Flechette program has run into trouble, both on grounds of cost, and on technical grounds including accuracy. Flechette ammo has not come into general service anywhere, although the US Army made use of certain types of flechette ammo in Vietnam, primarily by the "Point man" of an infantry section operating in jungle country, the flechettes here being usually fired from a shot gun type weapon

Single flechette ammo, on which most research effort has been spent, consists of a small metal cartridge case, commonly of nominal 5.6mm cal, into the neck of which is placed the flechette itself, with the narrow body of the arrow secured at the point by a sabot, filling the gap between the case neck and the flechette. The full length of the flechette is contained within the cartridge case, the fins being positioned almost on the inner base of the case. When fired the sabot is discarded at the muzzle by means of a stripper, integral with the muzzle, allowing the flechette to continue on its fin-stabilized flight (Fig 1)

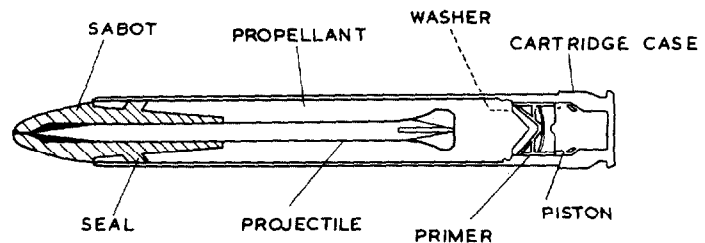

Fig 1 Typical Piston Primed Single Flechette Cartridge (from Ref 2)

To reduce weapon wt and achieve simplicity in what are weapons with exceptionally high cyclic rates of fire, some flechette cartridges are piston primed. In such cartridges the primer

is fired by a small piston actually contained in the base of each cartridge case. After firing the piston is forced back by gas pressure, and in turn forces back the firing pin on the rifle. This unlocks the breech block, and residual gas pressure drives the cartridge case back and gives sufficient energy to the breech block to carry out the cycle of operations. This system obviates the necessity for a convention gas system in the weapon, but piston-primed ammo is difficult and costly to make

Various flechette cartridges to fit the Salvo and SPIW projects have been made in the US. Apart from single flechette types with metal cases, a number of different multi-flechette cartridges, usually based on commercial shotgun cartridges, have been made, usually with cases of plastic material. Apart from normal flechette, proof, tracer and dummy cartridges have been produced in a variety of case types. Sabots have generally been made of nylon or fiberglass, and have caused much trouble because fine particles may blow back into the firer's eyes when the discarded sabot disintegrates at the muzzle

The flechettes themselves are usually made of steel, but other materials have also been used. A particular aim has been to use a metal with as high a density as possible, and bi-metal flechettes have also been used, where the front portion has been of the heavier metal, leaving the tail light, and the center of gravity far forward

A characteristic of single flechette ammo, apart from the high velocity given to the dart, is the low wt of the dart and of the complete cartridge. A typical 5.6mm flechette cartridge (the XM.144) weighs 93 grains (6g) in all, with the flechette itself weighing between 8 and 10 grains (0.5–0.65g) plus about 7 grains (0.45g) for the sabot. Even the longer XM.110, with its piston primer, has a total cartridge wt of only 98 grains (6.35g). Muzzle velocities of single flechette cartridges with darts weighing 8 to 10 grains range between 1370 and 1430m/sec and, surprisingly, these light projectiles have a good armor piercing performance. Fired against 6.3mm and 3.15mm hard steel plate, as well as Al plate, at 130m range, at angles of attack of 90 degrees and 60 degrees, the 10 grain flechette achieved penetration and compared very favorably with 5.56mm M.193 ball and M.80 7.62mm ball. Flechettes were found to retain striking

effect out to 500m, but were inaccurate – a fault which continued to dog the entire flechette program

When the flechette emerges at the muzzle, the fragments of the sabot, having a poor ballistic shape and little mass, soon fall to the ground. The flechette itself, with a launch velocity of 1430m/sec, loses velocity rapidly as it proceeds down range, due to its light wt. It would arrive at a target 400m distant with a residual velocity of about 1030m/sec. At this point the flechette's remaining energy is about 25 kilogrammeters. The wounding efficiency of the flechette is of a high order in that, due to its shape and the fact that this shape degrades immediately upon impact with flesh, this remaining energy is quickly given up to the target. (Flechettes tend to buckle into a hook upon impact with flesh, and since this is a very poor ballistic shape, and since flesh is about 800 times denser than air, the buckled flechette gyrates and gives up its energy very rapidly, thus earning high marks as an effective projectile)

In the search for the optimum weight flechette in rifle cal, darts weighing 18.5 grains (1.2g) were produced, giving muzzle velocities of around 1160m/sec

A requirement existed for tracer flechette, with ignition at 25m from the muzzle, and good day and night trace to 500m. Despite a number of different approaches to this, the requirement was found impossible to meet. The small cross section of the flechette made the conventional trace chamber ineffectual. Apart from trying the conventional chamber, other solutions included coating the entire rear of the dart with tracer compn, and also making the rear of the dart entirely of Mg

A wide variety of US flechette cartridges were made, the most frequently encountered being the following:

- XM.110: 5.6mm single flechette. Belted, rimless, bottlenecked case with piston primer. Case length 52.8mm. Overall length 58.8mm
- XM.144: 5.6mm single flechette. Rimless bottlenecked case. Conventional primer. Case length 43.9mm. Overall length 49.6mm. Head diameter 8.1mm
- XM.215: 5.6mm single flechette. Rimless

bottlenecked case. Conventional primer. Case length 43.9mm. Overall length 49.3mm. Head diameter 8.5mm. The XM.215 was a wide-case variant of the XM.144

XM.645: 5.6mm single flechette. Belted, rimless, bottlenecked case with piston primer. Case length 57mm. Overall length 62.5mm. This cartridge will be found with Canadian arsenal headstamps

Each of the above was manufd in variant forms. These variants incorporate a number of changes from the basic, including case taper differences, size of primer, wall thickness, type of flechette and tracer. In addition the basic forms (and probably some of the variants too) were produced in proof and dummy loadings

The potential of multi-flechette loadings was realized early, and AAI tried, in 1957, a multi-flechette cartridge based on a 12 gauge shotgun

case. In flechette form: these cartridges were often referred to as being of 18.5mm cal. The 1957 AAI cartridge, known as type "A-LI" had 32 flechettes, each of 13 grains (0.84g) wt. Muzzle velocity was 426m/sec

At least two other types of 18.5mm shot-shell flechettes existed, in the following forms:

- (1) 26 flechettes, of normal finned type, with total weight of 240 grains (15.55g). Muzzle velocity 548m/sec; and
- (2) 18 flechettes of "mass stabilized" type, having a thicker form than normal, the pointed front end having heavier metal than the rear. The rear had no fins. Total weight of flechettes 390 grains (25.27g). Muzzle velocity 518m/sec

Flechette cartridges in 10.4mm, 7.62mm NATO and .45 inch ACP have also been manufd in the US. Apart from the cartridges listed above, which were strictly military in origin, Amron Corp in the US, with interests in the armaments

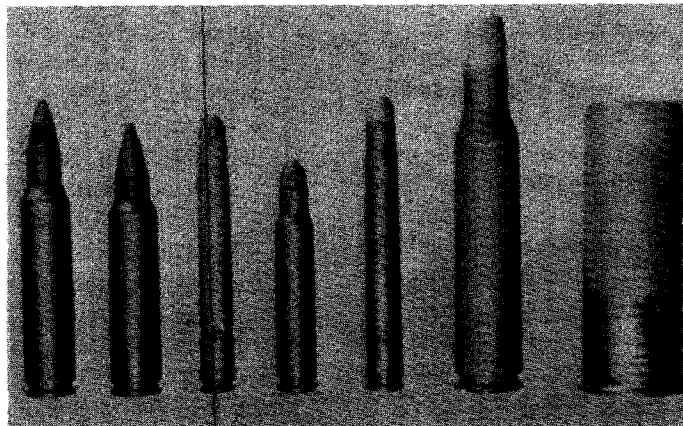

SPIW/Flechette ammunition. Left to right: 6.35mm FA-T 124 (52.6mm case); 6.35mm Winchester (47.6mm case); XM110 flechette (USA); XM645 flechette (USA); 8.35mm Amron multi-flechette (USA); Multi-flechette (USA)

Fig 2 (from Ref 2)

area, produced a number of flechette types. Of particular interest was their 8.35mm multi-flechette. This utilized a large capacity, conventional type case with normal primer. The bottlenecked rimless case measured 68.7mm in length, overall length being 79.2mm. A cluster of four flechettes was positioned in the neck of the case by a single sabot. This cartridge was manufd with brass and Al cases

Development of SPIW/Flechette was carried out in the US by AAI, Winchester Western, Harrington and Richardson and Springfield Armory. This field of four was narrowed down to AAI and Springfield Armory, a number of different weapon designs, many of unconventional appearance, being produced. By 1970 the program had been further narrowed down to one weapon considered suitable for limited field tests, namely the XM.19 rifle, developed by AAI, although two further weapon designs were still then under development. The XM.19 was, like many of the other weapons produced for flechette, smooth-bored, and fired the XM.645 single flechette cartridge, the weapon being recoil-operated. It was intended that this weapon fire three-round controlled bursts, but sustained bursts of automatic fire were also possible. Total wt for rifle and 200 rounds of ammo was intended to be within the set limit of 12lb (5.44kg). The XM.19 achieved grenade launching capability by means of a detachable launcher

Flechettes have been used for a variety of larger weapons also, including heavy machine guns, 20mm cannon, and light artillery, flechette in the latter weapon being close to the original concept of "grapeshot". Flechette in rifle cal has also been the subject of trials elsewhere in the West. Basically however, in the rifle role, it has not yet fulfilled the hopes originally placed in it (Ref 2)

Refs: 1) E.C. Ezell, "Small Arms of the World", 11th Ed, Stackpole, Harrisburg (1977), 47-49
2) D.H.R. Archer, Ed, "Jane's Infantry Weapons-1978", Franklin Watts, NY (1978), 367-68

Spontaneous Combustion. See under "Combustion, Spontaneous or Self-Ignition" in Vol 3, C429-R to C430-L; "Dust Explosions" in Vol 5, D1578-R to D1579-R; "Ignition, Spontaneous, of Explo-

sives" in Vol 7, I24-L to I25-L; and "Pyrophoric Incendiary Agents" in Vol 8, P502-L to P504-R

In the *Addnl Ref* existing information on spontaneously combustible solids including pyrophoric-air hazardous materials and w reactive materials are reviewed. Pertinent data on (a) the causes and prevention of spontaneous combustion in organic and inorganic materials due to air and w reactivity, (b) the application of various mathematical treatments to spontaneously combustible materials, and (c) available test methods for assessing the flammable properties of spontaneously combustible materials, eg, autoignition temp and spontaneous heating are also included
Addnl Ref: E.G. Kayser & C. Boyars, "Spontaneously Combustible Solids; A Literature Survey", DOT-TES-20-75-1, Naval Surface Weapons Center, White Oak Lab, Silver Spring, Md (1975)

Sporting Powders (Sporting Smokeless Propellants) and Ammunition. See under "Bulk and Condensed Powders" in Vol 2, B322-L to B323-L; and "Pyrodex" in Vol 8, P500-L

Current US manufd sporting powders are as follows:

Dupont *shotshell powders:* Hi-Skor 700-X Double Base, PB, SR-4756, SR-7625, and IMR-4227; *rifle powders:* IMR-3031, 4064, 4198, 4227, 4320, 4350, 4831 and 4895; *pistol powders:* PB, IMR-4227, Hi-Skor 700-X, SR-7625, SR-4756, IMR-3031 and IMR-4198

Hercules *shotshell powders:* Herco, Unique, Blue Dot, Red Dot and Green Dot; *rifle powders:* Unique, Reloder 7 and Hercules 2400; *pistol powders:* Unique and Bullseye

Hodgdon *shotshell and pistol powders:* HP38, TRAP100, HS-5, HS-6, HS-7 and H110; *rifle powders:* H4227, H4198, H322, Spherical BL-C Lot No 2, Spherical H335, 4895, Spherical H380, Spherical H414, H205, Spherical H450, 4831-Newly Manufactured and Spherical H870

Norma *shotshell powders:* Norma 2010 and 2020; *rifle powders:* Norma 200, 201, 202, 204 and Magnum Rifle Powder; *pistol powders:* Norma 1010, 1020, Powder R-1 and Powder R-123

The Ref contains a complete description of all US manufd sporting ammo:

Centerfire pistol and revolver ammo manufd

by Federal, Hornady, Norma, Remington-Peters, Smith & Wesson and Winchester-Western
Centerfire rifle ammo manufd by CCI, Federal, Peters, Remington, Western and Winchester

22 *Rimfire* ammo manufd by CCI, Federal, Peters, Remington and Winchester-Western

Ballistic tables are also included for all Federal, Norma, Peters, Remington, Weatherby and Winchester-Western ammo

The manuf of shot for shotshells is of both historic and modern interest. The forerunner of modern shot is the old grape shot of the middle ages which is mentioned as far back as 1420. By the year 1510 this was employed in the earliest handguns. Actual manuf in the form of balls dates back to BritP 725 (1758) wherein the shot was poured and then polished in drums. The first "shot tower" was constructed in Austria in 1818 based on BritP 1347 of 1782

The exact compn of shot varies but it is principally of Pb with some As added, which has the property of not only making the Pb harder but of making it flow more readily. The As content in small size shot may run approx 0.2%, and in larger shot sizes nearly twice that amt. This alloy is made up into blocks which are then used for shot manuf, usually by one of the following two methods: 1) The melted alloy is poured thru a sieve-like container from which the ball shaped drops fall from a considerable height into a tank of cold w. In the course of the fall the shot becomes rounded and the size depends upon the sieve. For very small sizes the drop height is usually 100 ft, and for larger sizes as much as 100 yds. 2) The melted alloy falls upon a quickly rotating metal disc from which the pellets are thrown by centrifugal force against an apron and then dropped into w. The size of the shot depends upon the speed of the revolving disc. The sorting of the shot for sizes is accomplished by rolling them down a surface with various size openings. The shot which have thus been sorted are mixed with very finely ground graphite and placed in revolving drums. This completely rounds the shot and covers them with a graphite coating which protects them from oxidation. Hard shot contains, in addition to As, about 2% Sb. Such shot retain their form better than soft shot and consequently are less apt to stray away from the central shot mass, and thus give a better firing

pattern with greater penetration. The most essential point is that the shot be round, which is much more important than exact sizing. The characteristic of hard shot is enhanced by Cu plating, but this adds considerably to the cost and relatively little to performance

Ref: R.F. Scott, Ed, "Shooter's Bible", No 69, 1978 Ed, Stoeger Publishing Co, South Hackensack, NJ (1977), 468-519

Spot Tests for Explosives and Propellants.

See under "Color Reactions and Color Reagents" in Vol 3, C405-L to C420-L

Spotting Charges. Spotting charges are used for locating point of impact, for target acquisition, for tracking, and for indication of item or component functioning. For many years, spotting charges of BlkPdr were used in practice bombs and projectiles to locate point of impact. Because the observation distances were relatively short and because a relatively large volume was available for the spotting charge, an adequate flash could be produced with BlkPdr. The development of long range missiles, as well as the use of small arm projectiles as spotting rounds for major caliber weapons, led to a requirement for more effective spotting charges

Small caliber spotting rounds can be used to aim a major caliber weapon. In operation, the small caliber spotting rifle, which is rigidly attached to the main weapon, is fixed and the point of impact is indicated by a flash of light and a puff of smoke formed by the functioning of the small caliber projectile. As the trajectory of the small arm spotting projectile and that of the main round are nearly identical at the critical range, the burst provides information for adjustment of aim. A hit with the spotting round means that the main projectile will also strike close to the target (Refs 1 & 5)

Fuzeless target practice cartridges are used in lieu of expensive HE contg mechanically fuzeed rounds, to produce a flash and smoke signal upon impact of the projectile with the target. In a 40mm projectile, this is accomplished by the use of a controllably sensitized pyro compn, reactive on impact or abrasion, and an ogive-anvil-spike configuration designed to easily rup-

ture upon low-force impact. The signature from as little as 10g of the powdered Mg-red P-Ba nitrate compn is visible by day or night for well over 1000m (Refs 6 & 7)

Highly accurate trajectory information is required in the development of a missile system. One method of obtaining this information for a missile at high altitudes is to photograph the flash produced by a photoflash cartridge ejected a distance sufficient to prevent damage to the missile in flight. A device was developed which produces a series of flashes with a known time interval between them (Ref 3)

Flash charges are also used to provide a visible indication of the functioning of an item or component such as a warhead fuze. The flash signal provides a brilliant light flash and can be photographically recorded by remote cameras, providing data so that the time and location of functioning can be accurately detd (Refs 2 & 4)

Refs: 1) R.T. Eckenrode, "The Spotting Technique: Effect of Ambient Illumination, Spot Intensity and Color, Memory Screen Information", Memo for Record, Project 754, Frankford-Ars (Oct 1955) 2) R.G. Weldon, **NAVORD 5860**, BuNavWeps, Washington (1958) 3) D.D. Collins, "Pyrotechnic Flashes and Flares in Guided Missile Tracking", MilPyroSect-Mtg, AOA, RedstoneArs (1959) 4) J.W. Haldeman, **NAVORD 7055**, BuNavWeps, Washington (1960) 5) R.T. Eckenrode & F.L. Marian, "The Spotting Technique: The Question of Spot vs Smoke and Spot Duration", Memo for Record, Project TS4-4020, FrankfordArs (Nov 1964) 6) J.A. Carrazza et al, "Development of the 40MM XM438E1 Target Practice Cartridge", **PATR 3901** (1969); Anon, **Ord n LIV**, No 300 (1970), 636; J. Weinszen et al, **USP 3645208** (1972) 7) Ellern (1968), 120-21

Språng gummi. Trade name of a Blasting Gelatin (see Vol 2, B211-R) distributed in Norway by Norsk Språngstofindustri
Ref: R. Meyer, "Explosives", Verlag Chemie, NY (1977), 246

Spread of Detonation. See under "Detonation (and Explosion), Initiation (Birth), and Propagation (Growth or Spread) in Explosive Substances" in Vol 4, D402 ff

Sprengel and Sprengel Type Explosives. Expls of a new type introduced in 1871 by Hermann Sprengel, who patented [BritP 921 & 2642 (1871)] a series of mining expls based on simple oxidation-reduction mixts. The essential novelty of the invention lay in the fact that the materials were mixed *in situ* just before use, and the resultant expl mixt was fired immediately by means of a blasting cap. Among the combustible materials advocated were Nitrobenzene, Nitronaphthalene, CS₂, petroleum and PA. Among the oxidizing agents patented were K chlorate, strong or fuming nitric acid and liq NO₂

Although strong nitric acid is extremely corrosive and inconvenient to handle, it was used in several Sprengel Type Explosives, such as:

Oxonite. Accdg to Ref 4, p 354, it consisted of PA 58 and fuming nitric acid 42%. However, accdg to Ref 5, p 02, Oxonite was a Brit expl invented by Punshon, contg PA 46 and strong nitric acid enclosed in a glass vial which was broken just prior to use

Hellhoffite. Contained 28p Nitrobenzene and 72p nitric acid. Accdg to Guia (Ref 7, p 402), Hellhoffite as proposed by Raoul Pictet, consisted of nitrogen peroxide and alc or eth

The strength of these two expls was about equal to that of 70% Dynamite, but they were much more sensitive to impact. They could be initiated with a fulminate blasting cap, but if the cap material was Cu, it could be eaten thru by the nitric acid, thus causing premature expln of the fulminate

Of the above two expls, Hellhoffite was used extensively even though it was not permitted in Gt Britain because mixing of the ingredients *in situ* was held to constitute "Manufacture" within the meaning of the Explosives Act of 1875, and as such could be carried out lawfully only on licensed premises

Hellhoffite, and some other Sprengel Type Explosives, were used in the USA, France and Italy prior to their being introduced on a large scale into Siberia and China by American engineers when the first railroads were built in those countries. When Hellhoffite was absorbed on kieselguhr, the resulting plastic, extremely corrosive mass became known as *Guhrhellhoffite*

Other Sprengel Type Explosives include the *Panclastites* (see Vol 8, P4-L to P5-L), *Fielder Explosive* (see Vol 6, F20-R to F21-L), *Kirsanov Explosive* (see Vol 7, K13-R), and the

* **Prométhées** (see under "Explosifs 03" in Vol 6, E363-L)

The most serious disadvantage of the Prométhées, as well as of the Fielder and Kirsanov expls was that different cartridges absorbed varying quantities of the combustible liqs, and this uneven absorption could cause incomplete detonation

A similar type expl was used in 1885 for blasting out Hell Gate Channel at the entrance of New York Harbor (see under "Rack-a-rock" in this Vol, R1-L to R1-R)

Barnett (Ref 2, p 108) lists *Oxyliquits* as Sprengel Explosives. They are reviewed in depth under "Liquid Air and Liquid Oxygen Explosives" in Vol 7, L19-R to L26-L. See also under "Oxyliquid" in Vol 8, O62-R to O63-L

Refs: 1) Marshall 1 (1917), 378-79 and 2 (1917), 572 2) Barnett (1919), 108-09 3) Marshall 3 (1932), 154 4) Davis (1943), 353-57 5) Clift & Fedoroff 2 (1943), pp H1 (Hellhoffites), O2 (Oxonite), P1 (Panclastite), P13 (~~Prométhées~~), R1 (Rack-a-rock) and S16 (Sprengel Explosives) 6) Fedoroff & Clift 4 (1946), 35 (Fielder Explosive) and 49 (Kirsanov Explosive) 7) Guia, Trattato VI (1) (1959), 402 (Hellhoffite), 403 (Panclastiti), 397 (Prometeo) and 393 (Rack-a-rock) 8) R. Meyer, "Explosives", Verlag Chemie, NY (1977), 246

* **Spring Gages.** See under "Closed Bomb or Vessel" in Vol 3, C337-L to C339-L

"Springing" of Boreholes. The bottom of a small diameter borehole can be enlarged by lighting and dropping a gelatine Dynamite safety fuse primer into the hole. Its effect is to pulverize the rock in the vicinity and to expel it from the mouth of the hole in the form of dust. As a result, the bottom of the hole is increased in diam in the form of a bulbous-shaped chamber, which will then accommodate a larger quantity of expl. This operation is variously called *bulling*, *chambering* or *springing*. Care should be taken to allow the bottom of the hole to cool down before adding further expls

Refs: 1) A. Voigt, SS 6, 236-37 (1911) & CA 5, 3341 (1911) 2) C.E. Gregory, "Explosives for North American Engineers", Trans Tech Publications, Cleveland (1973), 142, 149, 171, 192 & 198

Sprint. US close-range ground to air anti-ballistic missile developed to provide a "last-ditch" defense against enemy ICBM's which eluded Spartan missiles in the Safeguard (qv) Ballistic Missile Defense (BMD) System. Sprint is a two-stage solid propellant cone shaped missile carrying a nuclear warhead which is launched from an underground cell. It is "popped" from its underground launcher by a separate charge which is placed underneath it when the Sprint is loaded. Its own motor does not ignite until it is clear of the surface. Sprint then has the highest acceleration of any US missile, and the degree of maneuverability essential to intercept an incoming thermonuclear warhead at low altitude. Fine adjustments to the missile's trajectory are made by command signals from ground radar

Sprint's length is 8.23m, diameter at base 1.37m, launch wt 3400kg, and range approx 40km. The Safeguard BMD System was deactivated in 1976

Refs: 1) M.H.H. Taylor & J.W.R. Taylor, "Missiles of the World", Charles Scribner's Sons, NY (1976), 130-31 2) R.T. Pretty, Ed, "Jane's Weapon Systems-1977", Franklin Watts, NY (1976), 31-32

Squash Head Shell. See under "Scabbing" in this Vol

Squeezebore Guns. See under "Salvo Squeezebore (SSB)" in this Vol

Squib. A small expl device, similar in appearance to a *Detonator* (qv), but loaded with low expl, so that its output is primarily heat (flash). Usually electrically initiated, and provided to initiate action of pyrotechnic devices and rocket propellants

An *Electric Squib* is designed for electrical firing of burning type munitions or to initiate operation of jettisoning equipment and shearing devices, or as igniters for rockets or for setting equipment in motion where a small expl device is required. It consists essentially of a tube containing a flammable material and a small charge of powder compressed around a fine resistance wire connected to electrical leads or terminals (Ref 1)

A great variety of squib types is commercially available, ie, open match squibs, thin-bottom squibs, and side-burning squibs. All these types of squibs are available with charge materials for specific effects, such as end flash, jet flame, hot slag, brisk flame burst, coruscating slag, and hot gas

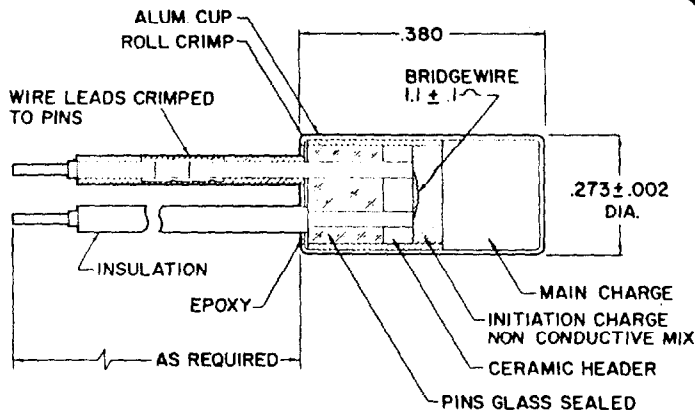

Fig 1 Cross-section through a Squib
(1 amp/1 watt) (from Ref 3)

In a typical squib, as shown in Fig 1, a bridge-wire embedded in a priming compn mounted inside a metal housing ignites an expl main charge which fires out of the housing to ignite or pressurize the device to be functioned. A single bridgewire, or when greater reliability is required, a dual bridgewire may be used in squibs. A typical bridgewire resistance is 1.0 ohm, a standard all-fire current is 4.5 amperes, and a standard no-fire current is 0.1 ampere. Squibs are generally used with a bridgewire resistance ranging from 0.1 to 4.0 ohms. Simple, lightweight squibs are equipped with pigtail leads, whereas other types have wire leads which are crimped to connector pins, as shown in Fig 1. The lead pins of the squib are hermetically sealed by a glass-to-metal seal which can withstand blow-back pressure of up to 30000 psi. The output end of the squib is solder-sealed and crimped for protection of the expl charge from deterioration during storage (Ref 3, p 45)

Squibs with redundant bridgewire circuits have three wire connections, of which one is being shared, or four connections. The two circuits can be energized from one electrical source or from two separate sources. Standard

squibs operate reliably at a temp range from -54° to $+150^{\circ}$. Squibs for higher and lower temp ranges can be manufd accdg to special requirements. Squibs with built-in time delays from msec to 30 secs have been developed for single or multi-step delayed action and for programmed sequencing of operations

Common sizes of squibs are from 0.194" diam to 0.170" in length to 0.750" diam and various lengths to accommodate delay trains of various lengths for different delay times. A great advantage of squibs is their light wt which ranges from 0.02 to 0.14 lbs (Ref 3, p 46)
Refs: 1) Anon, OrdnTechTerm (1962), 287-88
2) Blasters' Hndbk (1969), 96-97 3) K.O. Brauer, "Handbook of Pyrotechnics", Chemical Publishing Co, NY (1974), 44-46

Squid. Brit shipborne surface-to-sub-surface medium range anti-submarine mortar system. Developed by the Admiralty Underwater Weapons Establishment in the 1940's, with ship fitting starting about 1948

The ship's sonar provides submarine position data to a predictor which computes mortar aiming position. The triple-barrelled mortar fires a pattern of three mortar bombs which are programmed to give a three dimensional expl pattern ahead of the target. The bombs can be set to expld at variable depths using hydrostatic fuzes, and are also fitted with delayed action fuzes

The wt of the projectile is about 200kg and range is limited to about 400m

Although operational in the Royal Navy and other Commonwealth navies, Squid must be considered as obsolescent. Its successor, *Limbo*, utilizes a triple-barrelled mortar system which is stabilized in pitch and roll by a metadyne system referenced to the ship's stable platform. Loading is accomplished by pneumatic power horizontal ramming from a magazine which is located alongside the mortar. Projectile wt is about 200kg and range is somewhere between 1000 and 2000m

Limbo was developed during the 1950's and ship fitted in the early 1960's

Refs: 1) Anon, Ordn 37, No 193 (1952), 130
2) R.T. Pretty, Ed, "Jane's Weapon Systems-1977", Franklin Watts, NY (1976), 128-29

SRAM (AGM-69A). This USAF Short Range Attack Missile is a supersonic air-to-surface nuclear weapon, to complement and eventually replace the Hound Dog missile. It is deployed with the B-52G and H versions of the Stratofortress bomber, the swing-wing FB-111As, and has been designated for the B-1 strategic bomber

SRAM is designed to attack and neutralize enemy terminal defenses, particularly the Soviet surface-to-air missile (SAM) defenses. The weapon will have the capability of penetrating terminal defenses and striking mission targets while the bombers stand off outside the range of enemy defenses. It will also be able to attack enemy SAM and anti-aircraft sites so that bombers can strike primary targets with other SRAM or conventional bombs

The missile is 4.27m in length, 0.445m in diam and weighs approx 1010kg. Range varies between 55 and 160km, depending upon the flight profile employed, and a speed in excess of Mach 3 has been quoted. The nuclear warhead carried is stated to be of the same size as that of the Minuteman 3

An inertial guidance system is used, and the propulsion system is a two-stage solid rocket motor developed by Lockheed. The first stage provides initial acceleration; the second stage is activated as the missile approaches its target. Trajectory can be changed in mid-flight, and the missile can be launched to hit targets in any direction regardless of the bomber's flight path. The missile can be launched from either a high or low attack mode. The high mode is said to yield the greatest range but also increases the missile's vulnerability to enemy defenses

Four basic modes of flight trajectory can be employed: (1) semi-ballistic; (2) altimeter-controlled terrain following; (3) pull-up from behind radar screening terrain followed by inertial; and (4) a combination of inertial and terrain following. Lateral deviations in flight profile can also be programmed

The B-52 carries 20 SRAMs, 12 of which are mounted in two clusters of three missiles on each wing, with eight more carried internally. The FB-111 can carry six missiles, four on individual pivoting pylons under the wings and two internally. The B-1 will have internal stowage for 24 missiles, plus a max of eight externally. The

rotary launcher to be used with SRAM on B-1 and B-52 aircraft will permit the launching of eight successive missiles at 5-sec intervals

Refs: 1) M.J.H. Taylor & J.W.R. Taylor, "Missiles of the World", Charles Scribner's Sons, NY (1976), 132 2) R.T. Pretty, Ed, "Jane's Weapon Systems-1977", Franklin Watts, NY (1976), 151

SSP. Ger abbrev for Sicherheitsspreng pulver (safety explosive composition). An expl under this name, based on AN, was manufd by Société H. Müller et C° at Liège, Belgium
Ref: Daniel (1902), 737

SS-Waves. See under "Damage Potential of Air and Ground Blast Waves" in Vol 3, D3-R to D4-L

Stab Initiation. See under "Stab Detonators" in Vol 8, P381-R to P385; "Instantaneous Stab Fuze Detonators" in Vol 4, D844-L to D846-L; and "Instantaneous Stab Fuze Primers" in Vol 4, D850-L to D852-L

Stabilite. Trade name of a gelatinous industrial expl distributed in Fr by Nobel-Bozel and Société Anonyme des Explosifs. Its d is 1.30g/cc with a weight strength of 78%
Ref: R. Meyers, "Explosives", Verlag Chemie, NY (1977), 246

Stabilite II. Military proplnt contg NC 60 (mixt of 12 & 13% N NC's), NG 5, Trinitroanisole 34 and moisture 1%
Ref: Giua, Trattato 6 (1959), 364

Stability of Explosives and Propellants, Determination of. See under "Stability and Instability of Explosives" in Vol 6, E438-R
Addnl Refs: 1) Urbański 2 (1965), 23-28 2) A.J. Clear, "Standard Laboratory Procedures for Determining Sensitivity, Brisance and Stability of Explosives", PATR 3278 (Rev 1) (1970), 18-28

Stabilizers. Compds which, when added in small amts to other chemical compds or mixts, impart stability to the latter. In proplnt chemistry, especially so in the case of NC contg powders, the stabilizers employed are compds which, owing to their chemical structure, prevent the acid-catalyzed decompn of NC, NG and similar nitric acid esters

In common with other organic chemicals, NC tends to deteriorate with age by a process known as thermal decompn. In the case of NC, thermal decompn starts with the splitting off of NO_2 from the nitrate groups. This NO_2 reacts immediately with organic material in the proplnt (including NC) and is evolved as NO. The secondary action of the NO_2 with the NC accelerates the thermal decompn. Hence, thermal decompn should be minimized by adding to the formulation a chemical that will react with NO_2 to give a stable product and thus prevent secondary reaction of NO_2 with NC. The other product resulting from the loss of the NO_2 is a bound free radical which also tends to react further to more stable products. An additive to remove the free radical character of the residue should also result in stabilizing the proplnt. NG behaves in a manner similar to that of NC and can be stabilized in the same way (Refs 1 & 2)

Meyer (Ref 3) states that stabilizers exert their stabilizing effect by binding the decompn products, such as the free acid and nitrous gases, with the stabilizers themselves being converted into relatively stable compds at the same time. Neither stabilizers nor their secondary products should react chemically (saponification) with NC or NG. Compds used as stabilizers are mostly substitution products of urea and diphenylamine. Readily oxidizable compds — higher alcohols, camphor, hydrocarbons with double bonds (vaselines) — may also be employed. For such compds to be effective, their homogeneous incorporation into the formulation must be readily accomplished, they must not be too volatile, and must not be leached out by w. Many stabilizers also display plasticizing (gelatinizing) properties. Accordingly, they have both a stabilizing effect, and, in powder manuf, a gelatinizing (softening) effect

The stabilizers in current use in the US are diphenylamine (see Vol 5, D1416-R to D1426-R), 2-nitrodiphenylamine (see Vol 5, D1427-R to

D1430-R), and ethyl centralite (see Vol 2, C127-L to C137-L)

Other stabilizers, which are primarily used abroad, include **Akardit I** (as-diphenylurea), **Centralit I** (sym-diethyldiphenylurea), **Centralit II** (sym-dimethyldiphenylurea), **Centralit III** (methylethyldiphenylurea), **Akardit II** (methyl-diphenylurea), **Akardit III** (ethyldiphenylurea), ethyl — and methylphenylurethanes, diphenylurethanes, dibutyl and diamyl phthalates, camphor and vaseline

Refs: 1) Anon, *EngrgDesHndbk*, "Explosives Series—Solid Propellants, Part One", **AMCP 706-175** (1964), 48–49 2) Urbański **3** (1967), 559–67 3) R. Meyer, "Explosives", Verlag Chemie, NY (1977), 247–48

Stacking and Piling of Ammunition. See under "Piling and Stacking of Ammunition" in Vol 8, P301-L

"Stair-Case" Method. See under "Impact, Initiation of Explosion By" in Vol 7, I36-R to I37-L

Standard Muzzle Velocity. Velocity at which a given projectile is supposed to leave the muzzle of a gun. The velocity is calculated on the basis of the particular gun, the propelling charge used, and the type of projectile fired from the gun. Firing tables are based on standard muzzle velocity. Also sometimes called "prescribed muzzle velocity"

Ref: Anon, *OrdnTechTerm* (1962), 290-L

Standoff. As pertains to shaped charge ammo: The distance or spacing between the base of the liner and the target at the time of initiation. The "built-in" standoff is represented by the spacing between the base of the liner and the impact surface of the tip of the projectile. "Free space" is represented by the same distance at the time of functioning, allowing for the crush-up of the nose. "Air Space" is used to refer to this same spacing in underwater weapons
Ref: Anon, *OrdnTechTerm* (1962), 290-R

Stanzprobe (Ger). See under "Punch Test for Explosives" in Vol 8, P496-R

Starch. See in Vol 1, A398-L & R under "Amylopectin", and A398-R to A399-R under "Amylose"

Starch Dust Explosions. See under "Dust Explosions" in Vol 5, D1578-R to D1579-R

Starch, Nitrated. See under "Nitrostarch" in Vol 8, N157-L to N162-R

Starch Powder. A blasting expl patented in 1888 by Fitch and Reunert. It was prepd by incorporating 10p of NG into a mixt consisting of Na nitrate 73, charcoal 12, sulfur 10, and starch 5%

Ref: Daniel (1902), 21

Startex A. Trade name of a slurry blasting agent loaded in plastic hoses, distributed in Sweden by Nitro Nobel. Its d is 1.5g/cc and wt strength 72%

Ref: R. Meyer, "Explosives", Verlag Chemie, NY (1977), 248

Static Electricity and Sensitivity to Initiation by Electrostatic Discharge. See under "Electrostatic Discharges and Sensitivity of Explosives to Initiation by Them" in Vol 5, E38-L to E55-L
Addnl Refs: 1) M.S. Kirshenbaum, "Response of Lead Azide to Spark Discharges Via a New Parallel-Plate Electrostatic Sensitivity Apparatus", PATR 4559 (1973) 2) Ibid, "Functional Circuit Parameter Approach to the Electrostatic Sensitivity of Primary Explosives", ProcIntl-ConfResPrimaryExpls, ERDE, Waltham Abbey, Essex, Engl (17-19 March 1975) 3) Ibid, "Response of Primary Explosives to Gaseous Discharges in an Improved Approaching-Electrode Electrostatic Sensitivity Apparatus", PATR 4995 (1976) 4) Ibid, "An Improved Electrostatic Sensitivity Apparatus and Test Procedure for Characterizing Energetic Materials", Special Publication ARLCR-SP-77004 (1977), 329-50

5) H.D. Fair & R.F. Walker, Eds, "Energetic Materials-2, Technology of the Inorganic Azides", Plenum Press, NY (1977), 163-98

Stearic Acid and Derivatives

Stearic Acid (or Octadecanoic acid).

$\text{CH}_3(\text{CH}_2)_{16}\text{COOH}$; mw 284.47; white wax-like leaflets; mp 69-70° (slowly volatilizes at 90-100°); bp 361.9°, 383° (separate values); d 0.847g/cc at 70°; RI 1.4299 at 80°. Sol in acet, amylacetate, ethanol, benz, carbon tetrachloride, carbon disulfide, chl f and toluene. Occurs as a glyceride in tallow and other animal fats as well as in some vegetable oils. Obtd by washing high-grade tallows and yellow grease stearin followed by hydrolysis with Twitchell's or similar reagent, then boiling and distilling, and finally, cooling and pressing the product. Also, by hydrogenation from cottonseed and other vegetable oils. CA Registry No [57-11-4]. Autoignition temp 743°F; flash pt 385°F. Stearic acid forms both ester and salt compds, some of which are of Ordn interest

The patent of Brooks (Ref 2) claims that the addition of 0.3% stearic acid will retard the burning rate of BlkPdr. Livingston (Ref 3) reports that it was found possible to reduce the hygroscopicity of the charcoal used in BlkPdr by as much as 60% by using a stearic acid coating. Stearic acid is used in the so-called "French Ammonals" (see in Vol 1, A290 - Table). A very important usage for stearic acid is as a gelling agent in flame thrower fuels. See in Vol 6, F56-R to F59 - Table under "Flame Throwers - Liquids and Gels"

The US military specification for stearic acid is MIL-S-271B (Ref 4)

Accdg to Sax (Ref 5) stearic acid is slightly toxic

Refs: 1) Beil 2, 377, (170), [346], {990}&{1206} 2) C.W. Brooks, "Black Powder", CanP 348641 (1935) & CA 29, 3518 (1935) 3) S. Livingston, "Long Range Research on Improved Igniter Type Powders. Develop Non-Hygroscopic Igniter Powder", PATR 1612 (1946) 4) Anon, "Stearic Acid, Technical", MIL-S-271B (1962) 5) Sax (1968), 1120 6) Merck (1976), 1136-37 (No 8582) 7) CondChemDict (1977), 815

Aluminum Stearate (or Aluminum tristearate). $\text{Al}(\text{C}_{18}\text{H}_{35}\text{O}_2)$ (Ref 2), $\text{Al}(\text{C}_{18}\text{H}_{35}\text{O}_2)_{1.5}$ (Ref 3), $\text{Al}(\text{C}_{18}\text{H}_{35}\text{O}_2)_3$ (Refs 1 & 6); mw 313.51 to 877.35; white powder; mp 115° , $117-20^\circ$ (separate values); d 1.065g/cc at 30° (specific gravity 1.070). Sol in alkali, petr, turpentine oil; insol in ethanol, ether and w. Forms a gel with aliphatic and aromatic hydrocarbons. Prepn is by reaction in an aq soln of Al hydroxide, Al or activated (with Hg chloride in methanol) Al metal with stearic acid or Na stearate. The reaction product is filtered and dried. CA Registry No [637-12-7]

Al stearate has been used in expls to the extent of 11 to 14%. See in Vol 3, C543-R under "Coronite or Permittite". Accdgd to Cawley et al (Ref 2) it was used as a gelling agent-fuel in flame-thrower munitions developed during WWII. The fuels consisted of approx 5% Al stearate in gasoline, peptized with cresylic acid or ethylene glycol monoethyl ether acetate and mixed xlenols. As compared with unthickened fuels, Al stearate gels more than doubled the effective range of the flame thrower and also produced a much greater target effect, ie, it enabled four or five times the amt of fuel to be deposited on the target as had been found possible with fuels previously used. Further, ignition was much quicker using the gasoline-Al stearate gel fuels. Over 9,000,000 gals of this item were used in Europe alone during WWII. Cawley et al also report that storage stability of the gelled fuel mixts was detd by the "dropping ball" viscosity technique. The higher the viscosity, the greater the storage stability. However, for gels of a given viscosity, those contg the highest percentage of Al stearate soap and peptizer were the most stable in storage. See also in Vol 6, F54-R to F56-R under "Flame Throwers" and F56-R to F59 - Table under "Flame Throwers-Liquids and Gels". The patent of Bertrand and Grebert (Ref 4) claims that solid proplnt primers of low safety hazard and good mechanical properties can be obtd by including 1% of Al stearate in a mixt consisting of Al 25-35, K perchlorate 44-59, polytetrafluorethylene 5-20 and ZrO 10%. The inventors report that a typical primer consisting of Al 35, K perchlorate 54, polytetrafluorethylene 10 and Al stearate 1% has a combustion temp of 4070° with a gas

vol of 16.4 moles/kg and a Q_C of 2160cal/g; a rubbing sensy (Peter's appar) of 32kg, and an impact sensy of 8kg (versus 14.4kg and 0.6kg for a primer contg 41% Al and 59% K perchlorate). Kojima et al (Ref 5) claim that coating granular AN with 0.1 to 0.5% Al stearate will prevent storage agglomeration. Assman's patent (Ref 8) suggests that the coating of Al particles with Al stearate by sintering will provide even burning when 3% of the Al particles so treated are added to red P and Mg powder pyrot mixts. The inventor also claims that agglomeration during storage is also prevented by such an addn
Refs: 1) Beil 2, [351], {1009} and {1214} 2) C.M. Cawley et al, "Aluminum Stearate Gels for Use as Flame-Thrower Fuels", *JInstPetr* 33, 721-55 (1947) & *CA* 42, 3572 (1948) 3) W. Gallay & I.E. Puddington, "The Composition of Aluminum Stearate", *CanJRes* 26B, (2), 155-60 (1948) & *CA* 42, 5243 (1948) 4) Y.H.M. Bertrand & R.O.E. Grebert, "Powdered Primers", *GerP* 2242686 (1973) & *CA* 78, 149441 (1973) 5) K. Kojima et al, "Granular Ammonium Nitrate Composite", *JapP* 74-47300 (1974) & *CA* 82, 61424 (1975) 6) Merck (1976), 49-50 (No 366) 7) *CondChemDict* (1977), 36 8) B. Assman, "Incendiary Composition for Incendiary and Smoke Bombs, Hand Grenades, etc, Based on Red Phosphorus and Magnesium Powder", *AustrianP* 339800 (1977) & *CA* 88, 107543 (1978)

Ammonium Stearate (Octadecanoic acid ammonium salt or Stearic acid ammonium salt). $\text{C}_{17}\text{H}_{35}\text{COONH}_4$; mw 301.50; N 4.65%; tan, wax-like solid, free from ammonia odor; softens at $35-40^\circ$; mp $70-75^\circ\text{F}$ (?); specific gravity 0.89. Sol in hot ethanol and methanol; sol in boiling acet, benz, carbon tetrachloride, naphtha, w and xylene. Prepn is by reacting stearic acid with ammonium carbonate. CA Registry No [1002-89-7]. The stearate is combustible

Tomic's patent (Ref 2) suggests that a small amt of amm stearate incorporated into an oil emulsion expl mixt will form a w-repellant gel. Typically, AN 7, Na nitrate 15, and 75% aq AN 72p, are heated to 70° and emulsified with a mixt of amm stearate 1, domestic fuel oil 5 and 85% hydrazine-w mixt 0.2p, by cooling to 65° and adding 1p of hydrogen peroxide. The

expl produced has a specific gravity of 1.25, and detonates at 1.5° in a 1.5cm diam tube at 4233m/sec. After 24 hrs in w, the expl gave a Trauzl value of 48mm (as compared to no detonation from an expl prepd with a tetra ethylenepentamine—tall oil amide emulsifier). In another patent of Tomic (Ref 3) he claims that addn of a basic stearate such as amm stearate will produce an emulsion type expl that is w-resistant, pourable and nonsticky. As an example, AN 14 and Na nitrate 30p are dissolved at 160°F in aq 75% AN 144p. To this soln a mixt of amm stearate 2, stearic acid 1, No 2 fuel oil 10, and microballoons (30–325 mesh) 1p are added at 160°F to give a thickened emulsion of 1.33 specific gravity. This exhibited a detonation rate of 4000 to 5400m/sec, with Trauzl test values of 2-5/16 cubic inches and 1-13/16 cubic inches at 75° and 40°F, respectively
 Refs: 1) Beil 2, {1002} 2) E.A. Tomic, "Water-in-Oil Emulsion-Type Explosives", GerP 2141213 (1972) & CA 77, 90809 (1972)
 3) Ibid, "Emulsion Type Explosive Composition Containing Ammonium Stearate or Alkali Metal Stearate", USP 3770522 (1973) & CA 80, 49974 (1974) 4) Merck (1976), 75 (No 584)
 5) CondChemDict (1977), 53

Barium Stearate. $\text{Ba}(\text{C}_{18}\text{H}_{35}\text{O}_2)_2$; mw 704.39; white cryst solid (Ref 6); mp 160° (Ref 6), 240° (Ref 4); d 1.244g/cc at 30° (specific gravity 1.145). Sol in liq ammonia; insol in ethanol or w. Prepn is by reacting Ba hydroxide soln with stearic acid

Up to 2% of the stearate has been used as a lubricant and binding agent in the pelleting of Tetryl (Refs 2 & 3)

The US military specification for Ba stearate is **JAN-B-366** (Ref 4)

The stearate is regarded by Sax as being as toxic as Ba (Ref 5)

Refs: 1) Beil 2, 379, (172), [351], {1008} & {1214} 2) F.R. Benson, "Develop Processes for Recovery of Explosive Scrap", PATR 1287 (1943) 3) G. Weingarten, "Use of Calcium Stearate in the Pelleting of Tetryl", PATR 1337 (1943) 4) Anon, "Barium Stearate", **JAN-B-366** (1946) 5) Sax (1968), 452 6) CondChemDict (1977), 91

Calcium Stearate (Octadecanoic acid calcium salt or Stearic acid calcium salt).

$\text{Ca}(\text{C}_{18}\text{H}_{35}\text{O}_2)_2$; mw 607.00; granular fatty white powder; mp 147–49°, 150°, 179° (separate values); d (bulk) about 20 lb/cu ft. Sol in hot ethanol, hot vegetable oil and hot mineral oil; insol in eth, acet, chl, cold ethanol and w. Prepn is by reacting Ca chloride with Na stearate, then filtering off the product. CA Registry No [1592-23-0]

Weingarten (Ref 2) reports that Ca stearate is an adequate replacement for either Ba or Mg stearate as a lubricant and binding agent in the manuf of Tetryl pellets. Forchielli (Ref 4) employed Ca stearate as a hiding agent and lubricant for Comp A-3 (91/9 RDX/wax), thus developing Comp A-4/addend, 98/2.0, with no adverse effect on sensy to mechanical friction. LeRoux (Ref 5) markedly increased the w-resistance of "N" type expls by incorporating 1% of Ca stearate in the compns. The new formulations were called "NR" ("R" for w-resistant), and consisted of various mixts contg varying percentages of TNT, AN, Dinitronaphthalene, Na chloride, Pentolite 20/80, Al, wood dust and Ca stearate

The US military specification for Ca stearate is **JAN-C-263** (Ref 3)

Accdg to the CondChemDict (Ref 7), the stearate has a low toxicity

Refs: 1) Beil 2, 379, (172), [351], {1008} & {1213} 2) G. Weingarten, "The Use of Calcium Stearate in the Pelleting of Tetryl", PATR 1337 (1943) 3) Anon, "Calcium Stearate", **JAN-C-263** (1945) 4) A.L. Forchielli, "Desensitization of High Explosives by Waxes, Semi-Plastic RDX Compositions", PATR 1787 (1950) 5) A. LeRoux, "Explosifs Du Type N Résistant A L'eau", MP 33, 265–82 (1952) & CA 47, 10227 (1953) 6) Merck (1976), 215–16 (No 1706) 7) CondChemDict (1977), 155

Ethyl Stearate. See in Vol 6, E330-L

Trinitroethyl Stearate. See in Vol 6, E330-L

Lead Stearate (or Stearic acid lead salt).

$\text{Pb}(\text{C}_{18}\text{H}_{35}\text{O}_2)_2$; mw approx 774.26; chalky white, fluffy powder, smooth and talc-like to the touch; mp 105°, 100–15°, 125° (separate

values); specific gravity 1.4. Sol in eth and hot ethanol; sl sol in w. Prepn is by heating a soln of Pb acetate with Na stearate. CA Registry No [1072-35-1]

The major use for Pb stearate is in double-base proplnts (in amts of from 0.5 to 2.0%) as a burning rate stabilizer (producing a pressure plateau or mesa by lowering the burning rate), and as a moisture and smoke control agent (Refs 2-4 and 6-9)

The US military specification for Pb stearate is **MIL-L-758A** (Ref 5)

Sax (Ref 10) considers Pb stearate as toxic as Pb, ie, a *cumulative poison*

Refs: 1) Beil 2, (172), [351], {1010} & {1215} 2) J.M. Swotinsky, "Applied Research on Extruded Rocket Propellants Plateau-Producing Properties of a Number of Metals and Metal Compounds", PATR 1806 (1951) 3) J.E. Rainier, "Applied Research on Extruded Rocket Propellants—Development of Improved Solventless Rocket Propellant Composition", PATR 1851 (1951) 4) J.E. Rainier & J.M. Swotinsky, "Development of a Medium Burning Rate (0.45 inch/sec) Mesa-Type Rocket Propellant—T19 Propellant", PATR 1992 (1954) 5) Anon, "Lead Stearate (for Use in Ammunition)", MIL-L-758A (1962) 6) C. Lenchitz & J.P. Picard, "The Effect of Lead Stearate on the Thermodynamic Properties of a Propellant", PATR 3312 (1966) 7) Y.A. Tajima, "Mechanism of Catalytic Ignition and Combustion of Solid Rocket Propellants", Bimonthly Report No 1, NYU, Contract No DA-28-017-AMC-2222(A) (1965) 8) Ibid, Bimonthly Report No 2, Ibid (1965) 9) J.W. Lavitt, "Nitrocellulose Base Propellants", USP 3890175 (1975) & CA 83, 149783 (1975) 10) Sax (1968), 869 11) Merck (1976), 711 (No 5277) 12) CondChemDict (1977), 507

Magnesium Stearate (or Octadecanoic acid magnesium salt). $Mg(C_{18}H_{35}O_2)_2$; mw 591.27; soft white powder; mp 88.5°; specific gravity 1.028. Sol in chl_f-propylene-glycol and hot benz. Prepn is by reacting a Mg salt (such as the acetate) with a soln of Na stearate. CA Registry No [557-04-0]

Mg stearate is used in small percentages as a lubricant and binder for pelleting expls such as Tetryl (Ref 2). Leschinsky (Ref 2a) reported

the development of a foamed liq expl compn contg Mg stearate as a thickening agent and fuel specifically designed to initiate land mines if layered in depths of 1/2" or more, incorporating Mg stearate 8.0, Nitromethane 78.0, 1-Nitropropane 14.0% and using ethylene diamine 75 with methanol 25% added as the sensitizer. It was also reported that the expl could be detonated w-wet, and up to 45 mins after projection. Mg stearate is also used in double-base proplnts in small percentages as a burning rate stabilizer and moisture and smoke control agent (Ref 3)

The US military specification for Mg stearate is **MIL-M-542A** (MU) (Ref 4)

Refs: 1) Beil 2, 379, (172), [351], {1007} & {1213} 2) G. Weingarten, "Use of Calcium Stearate in the Pelleting of Tetryl", PATR 1337 (1943) 2a) A. Leschinsky, "Development of a Projection Method for a Foam Liquid Explosive", PATR 2113 (1955) 3) P. Tavernier, MP 38, 313 & 332 (1956) & CA 51, 15952 (1957) 4) Anon, "Magnesium Stearate (for Use in Ammunition)", MIL-M-542A (MU) (1973) 5) Merck (1976), 739 (No 5517) 6) CondChemDict (1977), 532

Zinc Stearate (or Octadecanoic acid zinc salt). $Zn(C_{18}H_{35}O_2)_2$; mw 632.33; white, hydrophobic powder, free from grittiness; faint odor; mp about 120°, about 130° (separate values); specific gravity 1.095. Sol in benz and hot common solvents such as chl_f; insol in ethanol, eth and w. Prepn is by reacting Na stearate with a soln of Zn sulfate. CA Registry No [557-05-1]. Zn stearate has an autoignition temp of 790°F and a flash pt of 530°F

The patent of Tamchyna and Vokac (Ref 4) claims that by incorporating Zn stearate with NG and EGDN a safer mining expl results. Fox et al's patent (Ref 5) claims that the addn of Zn stearate to the waterproofing material used to coat AN results in free-flowing granules of expl which can be successfully detonated after 20 mins under w using a pentolite primer. A study of the expl concn limits of Zn stearate and Fe, S and Zn stearate mixts is reported by Zemskii and Zhukov (Ref 7). The patent of Rose and Zimmer-Galler (Ref 2) claims that the addn of Zn stearate to pyrot delay compns eliminates or reduces the effect of temp change on the burning

rate. Thus, when W 35, Ba chromate 48.5% were treated with K perchlorate 10, diatomaceous earth 5 and Zn stearate 1.5%, respectively, the burning rate showed no change between environmental temps of +71° and -65°F

Sax reports that inhalation of Zn stearate can cause pulmonary fibrosis (Ref 3)

Refs: 1) Beil 2, [351], {1009} & {1214}

2) J.E. Rose & R. Zimmer-Galler, "Pyrotechnic Delay Composition Containing a Heavy Metal Soap", USP 3726730 (1973) & CA 79, 7573 (1973) 3) Sax (1968), 1247 4) V.

Tamchyna & F. Vokac, "Safe Powdered or Semigelatin Explosive", CzechP 154410 (1974) & CA 82, 127175 (1975) 5) R. Fox et al, "Coated Ammonium Nitrate", USP 3834955 (1974) & CA 83, 118067 (1975) 6) Merck (1976), 1310 (No 9826) 7) G.T. Zemskii & V.V. Zhukov, "On the Explosive Concentration Limit of Iron, Sulfur and Zinc Stearate Powders and Their Mixtures", UsbPreduprezhdenie-VnezapnVozplomeneneniPoroshkov i Vzryvov-GazodispersnSistem 1975, 139-41 & CA 85, 8720 (1976)

Steel (Iron) Plate Tests for Explosives. See Vol 1, Introduction XIX to XX, and under "Brisance or Shattering Effect" in Vol 2, B265-L to B297-L

Steelites. Cheddite type expls patented in 1902 in Ger by E. Steele and manufd in Engl by Steelite Explosives Ltd. They contained K chlorate 72.5 to 75.5, oxidized rosin 23.5 to 26.5 and castor oil 0.5 to 1.5%. See refs under "Chlorate Explosives" in Vol 2, C206-R. See also under "Colophony-Starch Nitrated Mixture" in Vol 3, C404-L

Steinau Cartridge. Consisted of a small diam glass bottle contg concd sulfuric acid which was placed within a larger jar contg w. This jar, in turn, was placed in a porous bag contg CaO. When the ensemble was plunged into a bore hole (see Vol 2, B248-R) filled with w, the reaction $\text{CaO} + \text{H}_2\text{O} = \text{Ca}(\text{OH})_2$ resulted. As this is extremely exothermic, the heat broke the bottles, and sulfuric acid mixed with w and

$\text{Ca}(\text{OH})_2$. This caused an enormous evolution of heat which vaporized the w, resulting in steam pressure sufficient to burst the bore-hole

Ref: Daniel (1902), 738

Stellite. A high temp resistant material used as a small arms tube liner

Gun tube material must have diversified properties. It must have high strength to withstand the high proplnt gas pressures. It must be ductile to be able to respond favorably to the repeated quickly applied and released loads. It must be resistant to the erosive action of hot proplnt gases and the abrasive action of rotating bands (for a more detailed discussion see under "Erosion of Gun Barrels" in Vol 5, E112-R to E121-L). These properties must be maintained thruout the temp range of -65°F to approx 2000°F. The latter temp is estimated as that of the bore surface after continuous firing of a machine gun. No one material meets all these requirements. If one material has the needed strength, it may be susceptible to erosion; if erosion resistant, it may be too brittle. Combinations in the form of liners and plating overcome these deficiencies to an appreciable extent

Of the various high temp resistant materials tested for small arms tube liners, Stellite has the best properties (Ref 2, p 72). Because of its high mp and resistance to erosion, more rounds can be fired at faster rates than with other materials. Stellite 21 (MIL-C-13358) has the following chemical compn: Co 62.2, Cr 27.4, Mo 5.5, Ni 2.8, Fe 0.70, Mn 0.66, Si 0.53 and C 0.22%. Physical properties available include a d at 70°F of 0.229 lb/cu inch, the thermal coeff of linear expansion over several temp ranges, and mechanical properties at various temps (Ref 2, p 72, Tables 16 & 17)

Although Stellite is brittle at ambient temps, a steel tube cover prevents expansion and resulting failure. At high temps, the mechanical properties of Stellite are ideally suited for liners. Tensile strength ranges from 120000psi at 70°F to 33000psi at 1800°F. Ductility improves with increase in temp

Blank liners are received as tubular castings which are precision machined to fit the tube. Stellite liners are restricted to short lengths primarily because of clearance limitations during

shrink fit assembly

Refs: 1) Anon, EngrgDes Hndbk, "Elements of Armament Engineering, Part Three, Weapon Systems and Components", **AMCP 706-108** (1963), A-11 to A-12 2) Anon, EngrgDes-Hndbk, "Guns Series, Gun Tubes", **AMCP 706-252** (1964), 21 & 72 3) Anon, Engrg-DesHndbk, "Guns Series, Guns-General", **AMCP 706-250** (1964), 6-2 to 6-3 4) Anon, EngrgDesHndbk, "Ballistic Series, Interior Ballistics of Guns", **AMCP 706-150** (1965), 3-8 to 3-21

Stemming (Besatz, Bourrage). In mining parlance, "stemming" refers to the inert material used to plug up a borehole into which an expl charge has been loaded. The "classical" stemming materials are mud or clay noodles. Stemming brings about a more economical utilization of the expl charge, provided the expl columns employed are short and the detonation is effected at the mouth of the borehole

Stemming is mandatory if there is any danger of firedamp (see Vol 6, F29-L). The strongest stemming is not necessarily the best; if the stemming is too strong, deflagration may occur. In coal mining, w stemming cartridges have proven to be the most useful. They consist of plastic tubes filled with w, closed at both ends, which are easily inserted into boreholes, do not stem too strongly and make a significant contribution to the settling of dust and fumes

Stemming is not to be confused with *tamping*, the latter term meaning the slitting of expl cartridges followed by deforming them to completely fill the borehole by applying pressure with a wooden rod (see Vol 3, C376-L)

Refs: 1) C.E. Gregory, "Explosives for North American Engineers", Trans Tech Publications, Cleveland (1973), 125, 126, 136, 141, 151, 175-77, 223, 227, 233, 239, 240 & Glossary 2) R. Meyer, "Explosives", Verlag Chemie, NY (1977), 248-49

Stettbacher, Alfred (1888-1961). Swiss scientist specializing in expls. Author of "Die Schiess- und Sprengstoffe", A. Barth, Leipzig, first published in 1919 with a second edition in 1933. A supplement, "Spreng-und Schiessstoffe" was

published in 1948 by Rascher Verlag, Zurich, with a Spanish version, "Pólvoras y Explosivos", published in 1952 by G. Gili, Buenos Aires. Dr Stettbacher authored many papers on expls, particularly PETN and its compns, and their testing (Ref 13)

The following is a short resumé of Stettbacher's contributions to the expls field

Although Pentrit (PETN) was prepd as early as 1891 by Tollens and vonWiegand (see Vol 8, P86-R ff), no one realized the possibilities of using it as a HE for military and industrial purposes until Stettbacher prepd it on a semi-industrial scale during WWI, and described its properties. He continued his work with this expl, and as a result of his investigations PETN became known thruout the world (Refs 2, 3 & 5). Ger was the first great nation to use PETN as a military expl, its manuf there commencing sometime prior to WWII. Italy, Russia and Japan followed, and finally Engl and the USA began manuf during WWII

Stettbacher realized that PETN was too sensitive to be used per se as a bursting charge in projectiles, and proposed desensitizing it by incorporating wax, paraffin, oils or TNT, and such expl formulations were widely used during WWII

Another important contribution was the invention of plastic expls contg NG and PETN. These became known as **Pentrinite**, **Ammon-Pentrinite** and **Gelatine-Pentrinite** (Refs 4 & 11)

Stettbacher also realized the potential in using Hexogen (RDX) as a HE, and proposed a mixt with NG under the name of **Hexonit** (Ref 4), which proved to be practically as powerful and brisant an expl as **Pentrinite**

Although the phenomenon known as the Munroe-Neumann effect has been known since 1888, no one seemed to realize the tremendous possibilities inherent in using hollow (shaped) charges for military purposes until Stettbacher published the results of his work conducted subsequent to WWI (Refs 6, 7 & 11)

Other expls which were investigated and recommended by Stettbacher are liq mixts of Tetranitromethane with hydrocarbons (Refs 8 & 9). He also thoroughly investigated the role of Al in expls, and found it particularly effective in underwater expl applications (Ref 10). Stettbacher proposed the so-called "**Thermite**-

Zündung" (qv), but it did not prove to be practical

Finally, it should be noted that Stettbacher did considerable work on advancing the state of knowledge of initiating expls (Ref 13)

Refs: 1) A. Stettbacher, *SS* **11**, 182–84 (1916) [Pentaerythrit und sein Saltpetersäureester]

2) *Ibid*, *AngChem* **41**, 716–18 (1928) [Pentaerythrittetranitrat als Militärsprengstoff]

3) *Ibid*, *SS* **23**, 345–48 (1928) [Pentaerythrittetranitrat-Nitroglyzerin, Gemisch] 4) *Ibid*,

Nitrozellulose **4**, 222–27 (1933) & **5**, 6–9 (1934) [Pentrit und Hexonit] 5) A. Stettbacher,

"Schiess- und Sprengstoffe", Barth, Leipzig (1933), 172–75 6) *Ibid*, Nitrozellulose **6**,

59–62 (1935) 7) *Ibid*, Nitrozellulose **8**, 58–62, 79–85 (1937) 8) *Ibid*, *SS* **37**,

42–45, 62–64 (1942) 9) *Ibid*, Nitrozellulose **13, 14** (1942) 10) *Ibid*, *Protar* **9**, 33–35,

212–18 & 233–42 (1943) 11) *Ibid*, "Spreng- und Schiesstoffe", Rascher Verlag, Zurich

(1948), 84–85 & 133–34 12) *Ibid*, "Pólvoras y Explosivos", G. Gili, Buenos Aires (1953)

[Reviewed in *RevCienAppl* **7**, 271 (1953)]

13) A. Langhans, *Explosivst* **1961**, 10, p 245 [Obituary with portrait]

Stilbazole Perchlorates, The Trinitro. Expl compds prepd by Sauermilch (Ref 2) by dissolving either α or β trinitro stilbazole in hot aq 20% perchloric acid, then cooling the soln to produce the colorl shining leaflets of the perchlorate, which is then filtered off. The two perchlorates of interest are:

β -Trinitrostilbazole Perchlorate [or 3-(2,4,6-Trinitrostyryl)-N-perchlorate pyridine]

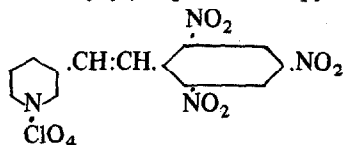

mw 415.703; N 13.48%; OB to CO_2 –76.98%; mp 176–81°. The perchlorate exhibits the following expl parameters: it crackles when rubbed with a pestle in a mortar, deflagrates at 190–200°, has a deton vel of 4820m/sec and a Trauzl test value of 290cc

γ -Trinitrostilbazole Perchlorate [or 4-(2,4,6-Trinitrostyryl)-N-perchlorate-pyridine]

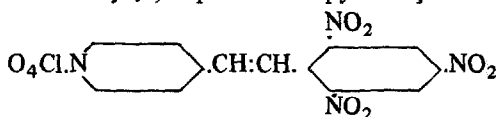

mp 220–223°. The perchlorate has the following expl parameters: it crackles when rubbed with a pestle in a mortar, deflagrates at 260–70°; and gives a Trauzl test value of 240cc

Refs: 1) *Beil* **20**, 441, (169) & [290]

2) W. Sauermilch, "Über Nitrostilbazole", *Explosivst* **8** (12), 269–71 (1960) & *CA* **55**, 8861 (1961)

Stilbene and Derivatives. For "Azostilbene and Derivatives" see Vol 1, A659-L to A660-L; also see under "Diphenylethylene and Derivatives" in Vol 5, D1454-L to D1457-R and the following *Addnl Refs:* 1) Anon, "Fifth Quarterly Progress Report on Investigation of High and Low Temperature Resistant Explosive Devices", NASA MSC, Request **T-32602** (G) (1966) [The effect of temp on the expl parameters of Hexanitrostilbene is reported and summarized below:

Test	Result
End Coupler Functioning Test at –315°F	At 32000psi loading press an avg (5 values) dent of 35.5 mils deep was observed in a 6061-T6 Al block
Compatibility with LA or L Styphnate (n) after 35 days exposure at 200°, cc/g	16.9 or 27.5
Small scale gap sensy at the 50% initiation stimulus level (20 shot avg), DBg (d)	5.25 (1.62g/cc)
Deton vel of 15 grains/ft, silver sheathed mild detonating fuze after exposure to 238° for 200 hrs, m/sec]	6150
2a) B.M. Dobratz, "Properties of Chemical Explosives and Explosive Simulants", UCRL-51319, Rev 1 , Lawrence Livermore Lab, UCalif, Livermore, USAEC Contract No W-7405-Eng-48 (1974), 18–33 [Contains a data (properties) sheet on HNS] 2) A.M. Yablonskaya et al, "Nitration of Some Stilbene Derivatives", <i>Sb-NauchTrKuzlasPolitekhnIn-T</i> 1974 , (69), 154–58 (Russ) & <i>CA</i> 83 , 192712 (1975) [Title only translated] 3) T.W. Stull, "Synthesis of	

High Purity Hexanitrostilbene", **MHSMP-75-37**, Mason & Hauger—Silas Mason Co, Amarillo (1975) [The development of a continuous process and the app for the synthesis of high purity Hexanitrostilbene Type I (HNS-I) are described. It is claimed that the information reported by this document will enable any facility to synthesize HNS-I at a purity level of approx 99.5% with yields approaching 38%]

4) D.J. Gould, "Thermal Stability of Hexanitrostilbene as Determined by Precise Measurements of Detonation Velocity", **SAND 75-5876**, Sandia Labs, Albuquerque (1976) [Gould reports that from measurements of deton vel made on 2-grain/foot, Al-sheathed mild detonating fuze (MDF) contg HNS, the thermal stability of small diam charges (or MDF) of HNS is greatly reduced by exposures above 200°, and that the procedure used to prepare the bulk HNS powder also has a decided effect on the thermal stability of the resulting MDF]

5) P.E. Rouse, Jr, "Enthalpies of Formation and Calculated Detonation Properties of Some Thermally Stable Explosives", *JChemEngrg Data* **21** (1), 16–20 (1976) [Rouse reports the ΔH_f° of Hexanitrostilbene as being 16.2 ± 2.5 kcal/mole and the exptl deton vel as 7130m/sec]

Stilbene Oxide. See under "a,a'-Diphenylethylene Ether and Derivatives" in Vol 5, D1457-R to D1458-R

Sting—Soft Rag. The US Army's STING Ring Airfoil Grenade (RAG) System was designed to control disorderly crowds while avoiding serious injury. STING RAG and its unclassified counterpart, SOFT RAG, were long-awaited developments sought by military and municipal authorities as an effective system to help restrain civil disturbances with a minimum of potential hazard

As its name implies, STING was developed to hit like a boxer's jab and cause pain without serious injury. SOFT RAG is identical to STING except that it contains a small quantity of CS powder, which causes sneezing and watering of the eyes

RAG projectiles are fired from launchers attached to standard M16 rifles, which are used by the US Army and National Guard troops, as well as many police departments. The projectile

configuration, developed from a thick one-piece body of soft rubber material, is shaped like an airplane wing and rolled into a ring similar to a streamlined doughnut

Ref: F. Bender, *The ARRADCOM Voice* (May 15, 1978), 2

Stinger Anti-Aircraft Guided Missile System. US man-portable, shoulder-fired guided missile system which enables the soldier effectively to engage low altitude jet, propeller driven and helicopter aircraft. Stinger is the successor to the Redeye weapon system (qv) which has been operational in the US Army and Marine Corps and elsewhere. Designed for the threat beyond the 1980s, Stinger has an all aspect engagement capability, an IFF system, improved range and maneuverability and significant countermeasures immunity. The system is a fire-and-forget weapon employing a passive infra-red seeker and a proportional navigation system. The missile contains a HE, hit-to-kill warhead, an electric control system and a dual thrust rocket motor, and employs a separable eject motor which launches the missile to a safe distance from the gunner prior to rocket motor ignition. The missile is 1524mm in length, 70mm in diam, weighs 13.4kg, and has supersonic speed — its range has not been disclosed

The *Stinger Alternate (Saber) AA Guided Missile System* was the name given to a man-portable AA guided missile system which has been in development in parallel with the Stinger system as a possible alternative replacement for Redeye in due course. Whereas the Stinger is essentially a modernized and improved version of Redeye, the Saber has a semi-active laser guidance system

A shoulder-held guidance unit incorporates a stabilized sight for target tracking and a laser projector whose beam is boresighted to the sightline. The missile thus requires an optical receiver to determine its position relative to the laser beam and correct the missile's flight appropriately. The range of the weapon is believed to be about 3km

Refs: 1) R.T. Pretty, Ed, "Jane's Weapon Systems—1977", Franklin Watts, NY (1976), 99 2) M.J.H. Taylor & J.W.R. Taylor, "Missiles of the World", Charles Scribner's Sons,

NY (1976), 140 3) D.H.R. Archer, Ed, "Jane's Infantry Weapons-1978", Franklin Watts, NY (1978), 586-87

Stockholms Superfosfat Fabriks Aktiebolag. BritP 17583 (1915) describes a family of expls prepd by mixing together 74-80p by wt of Amm chlorate, 6-18p of Si, ferro-Si, Al silicide or other silicide, 2-6p of wood-meal, and 4-10p of nitrated or unnitrated fraction of rock oil, boiling above 250°; 10-12p of a gelatine of NC with "liq trinitrotoluene" may be added
Ref: Colver (1938), 741

Stoke's Law. See in Vol 8 under "Particle Size Measurements of Solid Propellants, Explosives and Pyrotechnics", P20-R to P21-L, P34-L, P38-L, P39-L & R, P43-L & P43-R

Stokes Trench Mortar. Named after the inventor, Sir Wilfrid S. Stokes, this is a Brit light 3" (7.6cm) muzzle-loading mortar that fires a projectile (Stokes bomb) weighing 11 lbs. See also under "Cannon" in Vol 2, C27-R to C28-L
Refs: 1) J. Quick, "Dictionary of Weapons and Military Terms", McGraw-Hill (1973), 423
2) C. Chant, "How Weapons Work", Henry Regnery, Chicago (1976), 64

Stommonal. A Brit permitted coal mining expl contg NG 9.0-11.0, AN 59.5-62.5, Amm oxalate 5.0-7.0, woodmeal dried at 100° 5.0-7.0, and Na chloride 16.0-18.0%
Refs: 1) Barnett (1919), 134 2) Naoúm, NG (1928), 444

Stonite. Blasting expl, originally manufd in Ger and later in Engl and the USA. It contained NG 68, kieselguhr 20, K nitrate 8, and woodmeal, 4%
Refs: 1) Daniel (1902), 739 2) Barnett (1919), 98 3) Naoúm, NG (1928), 284

Stonobel. Brit permitted expl which passed the Buxton test (see Vol 3, C372-L to C373-L). It contained NG 25, AN 40.5, Na chloride 28,

woodmeal 5.5, and collodion cotton 1%. Its BalPend swing was 2.60"
Ref: Marshall 3 (1932), 120

Stooge Rocket. First radio-controlled rocket developed in Engl as a possible defense against bombers carrying atomic payloads. The weapon had a speed of over 500mph, and a range of approx 8 miles
Ref: Anon, Ordn 32, No 167 (1948), 344

Stoops Explosives. A mixt of 20p of $Mg(NO_3)_2 \cdot 6H_2O$ and 80p of AN was heated until both salts dissolved in the w of crystn. This was mixed, while hot, with balsam sawdust. On cooling, a bulky dry mass was obtained which was suitable for use as an absorbent (dope) for NG to form mining expls, including permissibles
Ref: B.I. Stoops, ChemMetEngrg 35, 676 (1928)

Stopin. Russ for Squib. Also refers to an igniter for pyrot and some expl compns. It consists of cotton thread which has been soaked in a concd soln of K nitrate and then coated with a paste consisting of pulverin (see Vol 8, P496-R) in gum arabic. Finally, it is coated with dry pulverin and subjected to slow drying. Its burning rate is 3 to 5m/sec
Ref: Gorst (1957), 124

Storage of Explosives. See under "Safety" in this Vol

Storite. A series of expls patented in Engl by Storer in 1893 consisting of bitumen (see Vol 2, B164-L) and an oxidant. A typical mixt contained bitumen 30 and K chlorate 70%
Refs: 1) Daniel (1902), 739 2) Giua, Trattato 6 (1959), 400

Storm, Christian George (1877-1947). Noted US authority in the field of expls. Author of numerous articles and govt publications on the properties, testing and analysis of smokeless

powder and high explosives. Dr Storm studied at Columbian College (now George Washington Univ) under Dr Charles E. Munroe, discoverer of the famous "Munroe Effect" (qv)

He served as explosives chemist at the Naval Powder Works (1901-1909); at the US BuMines (1909-1915); was directing chemist for Aetna Explosives Co (1915-1917); consulting expls chemist and Lt Colonel, US Ordn Dept (1917-1919); research chemist, Trojan Powder Co (1919); prof of chemical engineering, Ordn School of Application, Aberdeen Proving Ground (1920-1921); chief of expls section, Office Chief of Ordnance (1921-1942); and technical director, National Fireworks Co (1942-1945). He retired in 1945

Holder of a commission as Colonel in the US Army Ordnance Reservè Corps from 1923, Dr Storm was an active member of the Army Ordnance Association and the American Chemical Society. He served also as a co-editor (with Dr Munroe) of the Explosives and Propellants Section of Chemical Abstracts from 1931 to 1938, and as editor after Dr Munroe's death in 1939

Refs: 1) Davis (1943), 205 2) Ordn 32, 183 (Nov-Dec 1947) (Obituary)

Stowites. Brit expls similar in formulation to the *Samsonites* (qv in this Vol)

Refs: 1) Daniel (1902), 739 2) Marshall 1 (1917), 374

Stowmarket Explosion. A famous expln of the nineteenth century occurred at Stowmarket, Engl, on August 11, 1871, where about 30000 lbs of Guncotton expld in a powder magazine. All buildings to a distance of 200 ft were completely destroyed. In general, serious damage was confined to an area of 1500 ft distance, although weak walls collapsed up to 4000 ft. At 5 miles, the shock wave had enough force to bend an iron bar which was holding a door shut. Windows were reported broken up to a max distance of 7 miles, and the noise was heard more than 30 miles away

Ref: Meyer (1943), 395

Stowmarket Gelignite. See under "Gelignite" in Vol 6, G57-R

Straight Dynamite. See in Vol 5, D1594-R and D1596-R to D1599

Strain Gages. See in Vol 3, C341-L to C342-R

Strand Burning Rate Determination. In the early days of WWII, Crawford et al (Ref 1) developed the strand burner for detg the burning rates of extruded homogeneous proplnts. This method used solid strands of proplnt of about 1/8" diam by 7" long, which were coated with a plastic (eg, polyvinylalc) so that they would burn only from one end (cigarette-style)

To measure the rate of burning, fine wires of some low-melting metal (fuze wire) were threaded thru holes drilled diametrically thru the strand at accurately measured intervals (eg, 1"). Two or more wires were used. Each wire was attached in series with an electric timer. The strand was mounted in a holder and placed vertically inside a closed chamber. A given initial pressure was established in the chamber by using high pressure N₂. The initial temp was controlled by means of a constant-temp bath, and ignition of the strand was accomplished by means of a hot wire wrapped around it at one end

The strand was so prepared and mounted in the apparatus that when it burned thru the first wire, the timer would start. When it burned thru the second wire, the timer would stop. Thus, the time required to burn the measured distance between the two wires was recorded and the burning rate could be easily calculated. By having a surge tank attached to the strand burner, only a very slight pressure rise occurred as a result of the burning of the strand. Consequently, burning occurred at essentially constant pressure. This method has also been adopted for use with strands which have been cut from sheet proplnt and even strands sliced from sections of cast grains. Fig 1 shows a typical strand burner assembly

The chief advantage of this method is that burning occurs under carefully controlled conditions of temp and pressure with no appreciable

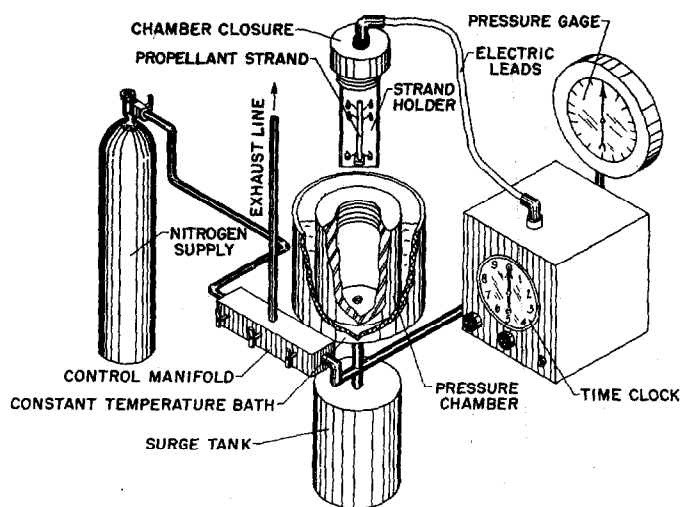

Fig 1 Diagram of a Typical Strand Burner

gas flow. In addition, the burning distances can be made large so that the precise measurement of these distances is not a critical matter. The main disadvantage is that proplnts do not normally burn as the strand does. For example, most proplnt grains burn in a direction perpendicular to the direction of extrusion; a strand burns in a direction parallel to it. In addition, the burning gases rise vertically from the strand surface. When the rocket grain burns, there is gas flow parallel to the surface. With some proplnts, the strand burner gives results which agree closely with data obtained from actual firings; with others, agreement is not too good

See also in Vol 2, B349-R to B350-R, and under "Closed Bomb (or Vessel)" in Vol 3, C334-L to C336-L

Refs: 1) B.L. Crawford et al, *AnalChem* **19**, 630 (1947) 2) F.A. Warren, "Rocket Propellants", Reinhold, NY (1958), 90-91 3) S. Fordham, "High Explosives and Propellants", Pergamon, NY (1966), 192-93 4) S. Tannenbaum & A.J. Beardell, "Characterization, Chemical Compatibility, Storability, and Hazard Testing of Liquid Propellants", in "Propellants Manufacture, Hazards and Testing", ACS Advances in Chemistry Series 88 (1969), 356-57

Strawcellulose Nitrate. Prepd by Rassow and Reckeler (Ref) by nitrating straw at 20° for

2 hrs with mixed acid consisting of nitric acid 19.8, sulfuric acid 66.7 and w 16.5%. The resulting product had 10.94% N which was reported as being comparable to that obt'd for cotton or woodpulp. See also under "Bjorkmann's Explosives" in Vol 2, B165-L and under "Paléine or Paléina" in Vol 8, P3-R to P4-L Ref: B. Rassow & A. Reckeler, "Ueber Acetylierung und Nitrierung von Bambuszelstoff", *Nitrocellulose* **3**, 42-5 & 61-4 (1932) & *CA* **26**, 3374 (1932)

Streak Camera (Streak Detonating Camera).

See under "Smear Camera, Streak Camera and Sweeping Image Camera" in Vol 2, C16-L to C16-R

Street Explosives or Streetites. See under "Cheddites or Streetites" in Vol 2, C155-L to C164-R

Strength of Explosives. The term *strength* refers to the energy content of an expl which, in turn, contributes to the force and power it develops and the work it is capable of doing

The straight Dynamites are the bases to which all other Dynamite grades are compared. The strength rating of a straight Dynamite designates the percentage by wt of NG in the formula; a 40 per cent straight Dynamite will contain 40 per cent NG, a 60 per cent grade will contain 60 per cent, etc. An erroneous concept is that the actual blasting power developed by different strengths is in direct proportion to the per cent markings; for example, that 40 per cent Dynamite is twice as strong as 20 per cent, and that 60 per cent is three times as strong as 20 per cent. Such simple ratios do not exist because NG is not the only energy-producing ingredient in straight Dynamites. A 20 per cent straight Dynamite contains 20 per cent of NG and 80 per cent of other ingredients which also contribute to the energy delivered by the expl. When the percentage of NG is increased to 60 per cent, the energy obtained from the NG alone is trebled, but that contributed by the remaining ingredients is reduced in the ratio of 80 to 40. Consequently, the energy gained by increasing

the NG is partially lost by the necessary decrease in other ingredients, and a 60 per cent straight Dynamite, rather than being three times as strong as a 20 per cent, is actually only one and one-half times as strong

In other types of Dynamites the proportion of NG is reduced and other strength-imparting ingredients, such as AN, are substituted. It is, thus, possible to produce a variety of Dynamites equaling the various grade strengths of straight Dynamite on a wt-for-wt basis. For example, one lb of 40 per cent ammonia Dynamite has the same strength as one lb of 40 per cent straight Dynamite, despite the fact that the former contains much less than 40 per cent of NG. The per cent strength markings for both of these grades are *weight-strength* markings, the ones most commonly used when referring to Dynamites of this type

Dynamites are sometimes graded according to their *bulk* or *volume* strength. This refers to the strength per cartridge of the expl, and the bulk-strength figure indicates that one cartridge of the Dynamite, so marked, has a strength comparable with one cartridge of straight Dynamite of the same percentage and size

Non-NG expls and blasting agents are also given strength ratings which designate their energy relative to an equal wt of a grade of straight Dynamite. Numerous methods of measurement and calcn have been devised to demonstrate the work potential of expls and blasting agents, but the data obtained by these various methods frequently are not in agreement with each other or with practical field experience. It is not difficult to formulate an expl or blasting agent with a very high total energy — the problem is to be able to utilize this energy for useful work. Experience has shown that two expls having the same measured or calcd energy do not necessarily produce the same blasting action in the field; in some cases a lower energy product will demonstrate superior blasting action at a given location

The total energy value of an expl can be meaningless. The energy must be available in time to do useful work. Velocity and density also are very important factors in detg blast performance. The best expl for a given operation is not necessarily the highest strength, density

and velocity; the best expl is that combination of strength, density and velocity which will give the type of blast results desired (Ref 1)

Meyer (Ref 2) states that the strength (arbeitsvermögen, force, performance potential) of an expl cannot be described by a single parameter. It is detd by the amt of gas liberated per unit wt, the energy evolved in the process (heat of expln, explosionswärme, chaleur d'explosion), and by the propagation rate of the expl (detonation velocity, detonations-geschwindigkeit, vitesse de détonation). If an expl is to be detonated in a borehole, the relevant parameter is its "strength"; in such a case the criterion of the performance is not so much a high detonation rate as a high gas yield and a high heat of expln. If, on the other hand, a strong disintegration effect in the nearest vicinity of the detonation is required, the most important parameters are the detonation rate and the density, ie, greatest brisance

Refs: 1) Blasters' Hndbk (1969), 75–76
2) R. Meyer, "Explosives", Verlag Chemie, NY (1977), 249

Strength Number. See under "Kraftzahl" in Vol 7, K18-L & R

Striker Composition. See under "Friction Primers" in Vol 8, P386-L & R

Strontium. Sr; at no 38; at wt 87.62; valence 2; two important radioactive isotopes (out of 12), Sr-89 and Sr-90; four stable isotopes, 88 (82.56% abundance), 86 (9.86% abundance), 87 (7.02% abundance), 84 (0.56% abundance); silvery-white metal, face-centered cubic structure; brief exposure to air results in the yel oxide; mp 752°, 757°, 769° (separate values); bp 1366°, 1384°, 1390° (separate values); d 2.6g/cc. Sol in acids, ethanol and liq ammonia. CA Registry No [7440-24-6]. Occurs in nature as the sulfate celestine or the carbonate strontianite; also found in small quantities associated with Ba, Ca, Pb or K minerals. Prepn is by a) electrolysis of molten Sr chloride in a graphite crucible with cooling of the upper cathodic space to isolate the Sr vapors, or b) thermal redn of the oxide

with metallic Al and vac distg off of the Sr. Chem reactions are similar to those of the alkaline earth metals such as Ca. The finely divided metal ignites spontaneously in air; reacts with w to evolve H₂; should be stored under naphtha in a glass bottle. Alloys contg a substantial proportion of Sr rapidly decomp w. The heat of reaction is usually sufficient to ignite the evolved H₂ (Ref 5a)

Livesay's patent (Ref 4) claims that expls and small arms proplnts can be codified for post-use identification by incorporation of microparticles of (unspecified) Sr oxides or salts of ≥ 0.1 wt % into recoverable fireproof carrier particles of a unique characteristic size (1–250 microns) and shape so that the total (micro plus carrier) particle has a d of ≥ 3 g/cc and an incineration temp of 400–500°

According to the CondChemDict (Ref 6) the stable forms of Sr have "... low toxicity ...". Sax (Ref 3) describes the radiation hazard due to the artificial Sr isotopes; "... ⁸⁹Sr, half life 50 days. Decays to stable ⁸⁹Y by emitting beta particles of 0.54MeV ... ⁹⁰Sr, half life 28 years decays to radioactive ⁹⁰Y by emitting beta particles of 0.54MeV ..."

Refs: 1) Gmelin, Syst Nr 29 (1931), 35–68
2) Ibid (1960), 1–151 3) Sax (1968), 1121–22 4) R.G. Livesay, "Coding Explosives for Identification After Explosion", GerP 2343774 (1975) & CA 83, 100322 (1975)
5) Merck (1976), 1143 (No 8624) 5a) Anon, "Fire Protection Guide on Hazardous Materials—Sixth Edition", NFPA, Boston (1975), 49 IM-399
6) CondChemDict (1977), 819 7) ChemRubHdb (1977), p B48–49; B164

Strontium forms many compds which are useful in ordn and are listed below

Strontium Carbonate. See in Vol 2, C59-R under "Carbonates and Bicarbonates" and in the following *Addnl Ref*: Merck (1976), 1143 (No 8628) (The CA Registry No is reported as [1633-05-02])

Strontium Chlorate. See in Vol 2, C200-R to C201-L and the following *Addnl Ref*: Merck (1976), 1143 (No 8629) (The CA Registry No is reported as [7791-10-8])

Strontium Chlorite. See in Vol 3, C246-L & R

Strontium Chromate. See in Vol 3, C282-R to C283-L and the following *Addnl Ref*: Merck (1976), 1144 (No 8631) (The CA Registry No is reported as [7789-06-2])

Strontium Diazide. See in Vol 1, A620-L to A621-L. Current CA indexes give the CA Registry No as [19465-89-5]

Strontium Hydride. SrH₂; mw 89.64; hydr white cryst solid; mp 675° (decompn); bp, sublims at 1000° (in H₂); d 3.27g/cc. The hydride is vigorously decompd by hot and cold w and moderately so by ethanol to liberate H₂. Prepn is by hydrogenation of oxide-free Sr at 200–1000°. Mixts of SrH₂ with solid oxidizing agents, such as chlorates, perchlorates or chromates, will react explosively if heated slowly
Refs: 1) Gmelin, Syst Nr 9 (1960), 150–51
2) D.T. Hurd, "An Introduction to the Chemistry of the Hydrides", Wiley, NY (1952), 45–46
3) G. Brauer, Ed, "Handbook of Preparative Inorganic Chemistry", Vol 1, 2nd Edn, Academic Press, NY (1963), 929–30 4) Sax (1968), 1123 5) ChemRubHdb (1978), B-164

Strontium Nitrate. See in Vol 8, N38-L to N39-L and the following *Addnl Refs*:

1) W.J. Puchalski, "The Effect of Angular Velocity and Composition on Pyrotechnic Performance", FA-TR-74011 (1974) [Pulchalski reports on the conclusions drawn from work involving Mg/Sr nitrate (28.8–42.8%/57.2–71.2%) mixts ignited and spun up to a rotational vel of 43000rpm; a) The burning rate of mixts consolidated at 70000psi into a 0.375" ID cylindrical cavity can be given by the eqn:

$$R = -0.148 + 0.729 \times 10^{-2} (M) - 2.75 \times 10^{-8} (M) (S) + 2.60 \times 10^{-6} (S)$$

where: R = burning rate in inches/sec

M = Mg % between 28.2 and 42.8

S = spin rate of sample in rpm to 43000;

b) the sample linear burning rate is directly proportional to the spin rate and/or the cavity diam; c) luminosity is directly proportional to Mg content and/or the increasing spin rate of the sample; d) slag content is unaffected by either a spin rate over 30000 rpm or the Mg content at such spin rates, and e) the burning surface of a spinning pyrot becomes convex] 2) Ibid, "Projectile Containing Pyrotechnic Composition

for Reducing Base Drag", USP 3886009 (1975) & CA 83, 118062 (1975) [The Pat claims that by including Sr nitrate in a pyrot booster compn for use in the base of both small-arms and artillery projectiles, vac drag will be reduced by increasing projectile void (projectile base vac) press (the result of the gas generated by combustion of the booster compn), thus increasing both projectile velocity and striking power. An example is reported of a 7.62mm bullet having a 0.3" column of a mixt of Mg 29.9, Sr nitrate 51.9, Ca resinate 8.2 and gelatin 10%. This compn burned at $3000 \pm 300^\circ$ and 0.128 inch/sec producing gases with an avg mw of 25-30, which raised the projectile void press to 12psi and increased the projectile velocity and striking energy by 16 and 34%, resp] 3) G.I. Altareva et al, "Pyrotechnic Composition with a Red Flame", RussP 527413 (1976) & CA 85, 194939 (1976) [The inventors claim a flare compn with greater tensile strength than previous compns, incorporating Sr nitrate 65-70, Al-Mg alloy 10-15, a butadiene-nitrile rubber (SKN-40T) 1-3, a urethane rubber (SKU-8A) 7-9, polyvinyl chloride 6-10 and Zn stearate 1.0-1.5%] 4) Merck (1976), 1144 (No 8637) (The CA Registry No is reported as [10042-76-9])

Strontium Oxalate. See in Vol 8, O32-L & R and the following *Addnl Ref*: Merck (1976), 1144 (No 8638) (The CA Registry No is reported as [814-95-9])

Strontium Perchlorate. See in Vol 8, P168-R to P169-L and the following *Addnl Refs*: 1) B.E. Doua, "Glycine-Strontium Perchlorate Compounds Synthesis, Characterization and Discussion", NAVAMMODEP RDTN 26, Crane (1963) [The author reports preliminary efforts to synthesize a pyrot compd of glycine and Sr perchlorate which would burn with a colored flame and contain its own oxygen and fuel supply] 2) Ibid, "Unique Chemical Compound; Synthesis and Characterization", NAVAMMODEP RDTN 52, Crane (1963) [The author reports the successful continuation of the effort previously initiated to synthesize a new pyrot compd:

Tris Glycine Strontium (II) Perchlorate.
 $[\text{Sr}(\text{NH}_2\text{CH}_2\text{COOH})_3] (\text{ClO}_4)_2$; mw 511.75 (estimated); white cryst; mp, stable to 260°

(decompn above); d 1.358g/cc. Sol in w. Prepn is by dissolving Sr perchlorate (1 mole) and glycine (3 moles) in w at 80° and cooling without stirring to 65° , at which temp the soln is seeded. The soln is further cooled to 25° , at which point the prod is crystd sufficiently to filter off. It is then dried at 100° . The perchlorate has an ign pt of 305° . The author describes the performance of a 1.437" ID by 2.25" long candle made by mixing 80g of the perchlorate with 20g of Mg and 3g of castor oil, and pressing into a boxboard tube, as having "... burned with strong red flame for 1 minute 20 seconds. Medium ash formation ..."]

3) U.A. Lehtikoinen & G. Franklin, "Tracer Incendiary Composition of Alkylaluminum", USP 3788908 (1974) & CA 80, 110526 (1974) [The inventors claim that incorporation of 30-75% of Sr perchlorate with 15-60% of C_{1-4} alkylaluminum compds will produce self-igniting tracer compns that have short ign delay periods and rapid burning rates with considerable flaring, the ability to withstand high press, and that are safe to handle and store. Compn prepn is under anhyd conditions in an inert atm. An example of a red flare compn is reported which includes 50/30/20% of Zr/Sr perchlorate/50:50 triethyl Al-trimethyl Al mixt] 4) U.A. Lehtikoinen, "Tracer Incendiary Materials Including Liquid Alkylaluminum and Compatible Inorganic Oxidizer", USP 3788907 (1974) & CA 80, 110527 (1974) [The Pat claims self-igniting tracer compns that have short ign delay periods and rapid burning rates with considerable flaring, are able to withstand high press, and are safe to handle and store. Prepn in anhyd inert atms is typical of mixts of 15-60% C_{1-4} alkyl Al compds and 30-75% Sr perchlorate with 30-75% of finely divided Al. Mixts such as the above are reported to burn brilliantly on exposure to the atm with an ign delay of <2 secs]

Strontium Peroxide. See in Vol 8, P192-R to P194-L and the following *Addnl Ref*: Merck (1976), 1144 (No 8640) (The CA Registry No is reported as [1314-18-7])

Strontium Picrate. See in Vol 8, P283-L

Stubenrauch's Explosives. VonStubenrauch of Ger patented a series of expls at the end of the last century: GerP 104443 (1896) – hot powdered charcoal, 12 to 14p, was treated with 5.5 to 7.5p of anhydr tar, and then mixed with 80p of powdered K chlorate and 0.5 to 1.0p of Ca or Mg carbonate; GerP 104505 (1898) – deals with waterproofing of expl charges by impregnating them with a liq consisting of oil and sulfur chloride; BritP 2264 (1898) – describes a smokeless powder contg NC and NG in which was incorporated the double oxalate of K and Cr; BelgP 135984 (1898) – describes an expl consisting of AN 80p and TNT 20p, to which was added pulverized K ferrocyanide; and BelgP 148978 (1900) – describes a HE obtained by treating nitrocresylic acid with K chromate or bichromate

Ref: Daniel (1902), 795–96

Studenisty (Zhelatin) Dinamit or Plasticheskii Dinamit. Russ for Gelatin or Plastic Dynamite. See under “Russian Nonpermissible Explosives” in Vol 3, C441-R

Stump Powder. Earlier American tree stump blasting expl which consisted of a kind of crude gunpowder to which NG and woodmeal (as absorbent for the NG) had been added. A typical formulation consisted of NG 20, Na nitrate 50, S 5, powdered coal 20 and woodmeal 5%

Ref: Barnett (1919), 98

Stürcke Explosive. Proposed in 1900 in the USA as a mining expl; NG 15, Na nitrate 59, AN 10, woodmeal 10, sulfur 1 and vaseline 5%

Ref: Daniel (1902), 745

Styphnate, Bis-basic-Diethyl Lead. See Vol 2, B141-L

Styphnate, Bis-Triethyl Lead. See Vol 5, D1288-L

Styphnic Acid and Derivatives. See in Vol 5, D1276-R to D1288-R; also in this Vol under “Resorzinat . . .” and “Resorzin . . .” and the following *Addnl Refs*: 1) J.F. Kenney, “Ammunition Priming Mixture and Compound Therefor”, USP 2689788 (1954) & CA 49, 7250 (1955) [It is claimed that glass or other abrasive material previously used in priming compns for rimfire cartridges can be eliminated and replaced by a double salt of styphnic acid, ie, Ferric Styphnate–Ferric Hydrophosphite, resulting in the following compn: Ferric Styphnate–Ferric Hydrophosphite 2–25, n-Pb Styphnate 25–50, Tetrazene 1–5 and Ba nitrate 40–65%] 2) H.S. Leopold, “Effect of Wire Temperature Upon Initiation Times of Four Primary Explosives”, NOLTR 72-123 (1972) [Leopold reports that when the induction time to hot wire ignition is compared between Ag Azide, LA, n-L Styphnate and basic L Styphnate at temps ranging from 550° to 3400°, the latter two always have the longest initiation times. Also, that pulsed hot wire initiation of both n-L Styphnate and basic L Styphnate gives a linear relationship between the log of the induction time and the reciprocal of the absolute temp (Arrhenius relationship)]

An addnl styphnic acid salt of interest is **Silver Styphnate** (or Silver trinitroresorcinat). $\text{Ag}_2(\text{C}_6\text{HN}_3\text{O}_8)$; mw 458.836; N 9.16%; OB to CO_2 –15.69%; orange crysts which darken slowly in sunlight; mp 300° (decompn). Sol in w; sl sol in acet, ethanol and eth. Prepn consists of adding to a boiling aq soln of 1,3,5-trinitroresorcin (after first buffering the soln with Na carbonate, then acidifying it with glacial acetic acid) an aq soln of Ag nitrate. After cooling the soln, the resulting ppt is filtered off, w-washed and dried. Yield is 83.04%. The salt has an impact sensy of 46cm (using a 500g wt) and a sand test of 15.4g of sand crushed using a No 6 detonator cap on a 1.000g sample (35.0g of sand crushed by MF as ref)

Brün's patent (Ref 3) claims the use of Ag Styphnate in priming compns for small arms cartridges

Refs: 1) Beil, not found 2) C.A. Taylor & E.P. Buxton, “The Explosive Properties of the Silver Salts of Some of the Nitro-Aromatic Compounds and Silver Oxalate”, Army Ordn 7, 68 (1926) & CA 22, 3571 (1926) 3) W.

Brün, "Ammunition Primers", USP 2097510 (1937) & CA 32, 357 (1938) 4) R. Böttger & H. Will, Ann 58, 298 (1946) & CA, not found

Styrene and Derivatives. See under "Dinitro-polystyrene" in Vol 8, N143-L to N144-R. The following is an addnl compd of interest

2,4,6-Trinitrostyrene.

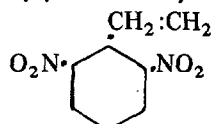

NO₂; mw 239.16; yel flakes; N 17.57%, OB to CO₂ -83.63%; mp 64-65°, 66° (separate values); d 1.61g/cc. Sol in benz-petr eth (50/50). Prepn is by treatment of a methanol-w (50/50) soln of beta-trinitrophenyl ethyl diethyl methyl ammonium iodide with Ag oxide. The 2,4,6-Trinitrostyrene prod is recrystd from a benz-petr eth mixt (50/50). The yield is 49% of theoretical. The Trinitrostyrene has an ignition temp of 305° and an impact sensy about that of RDX or Tetryl; ie, using an ERL machine with a 2.5kg wt and type 12 tools, a 50% probability of expln height range of from 20 to 40cm was found (Ref 3)

Refs: 1) Beil, not found 2) R.H. Wiley & L.C. Behr, "2,4,6-Trinitrostyrene", JACS 72, 1822-24 (1950) & CA 44, 7254 (1952) 3) W.F. Sager & D.V. Sickman, "Second Report on Research and Development in New Chemical High Explosives", NAVORD 483 (1952) 4) C.F. Bjork et al, "Synthesis of 2,4,6-Trinitrostyrene and Some Intermediates", JACS 75, 1988-99 (1953) & CA 49, 5338 (1955)

Subcaliber Ammunition. Ammo used with a gun or launching tube, usually in practice firing, of a smaller caliber than that which is standard for the weapon used. Subcaliber ammo is adapted for firing in weapons of larger caliber by subcaliber tubes, interchangeable barrels, sabots (qv), or other devices

Ref: OrdnTechTerm (1962), 294-R

Subcaliber Gun. Gun mounted on the outside and above the tube of a larger gun. It is used

in practice firing of subcaliber ammo, in connection with arming drills with the larger gun
Ref: Ordn Tech Term (1962), 294-R

Submarine Explosives. See under "Underwater Explosives"

Submarine Fuel, Winand's. Patented by P. Winant in the USA in 1909, it was intended to detonate without direct access to the atm. It consisted of a mixt of tetranitroethane and mono- and di-nitro benzene, without the addition of hydrocarbon material
Refs: 1) P. Winant, USP 914624 (1909); JSCI 28, 787 (1909) 2) C. Ellis, "Chemistry of Petroleum Derivatives", Vol 2, Reinhold, NY (1937), 1098

Subroc (UUM-44A). US underwater-to-underwater missile. Fired from the standard torpedo tube of a submerged submarine, it is designed to propel itself to the surface, then follow a ballistic trajectory to the predicted position of an enemy submarine, where it attacks with a nuclear depth bomb warhead. To make this possible, the large solid proplnt booster charge exhausts thru thrust-vectoring nozzles which enable the missile to change course underwater as well as in flight. The solid fuel motor does not ignite until the missile has travelled a safe distance from its launch submarine, which need not be pointing towards the target. The Subroc is propelled upward and out of the water. Its inertial guidance system then directs it towards the enemy craft, whose position, course and speed have been computed and fed into the missile guidance before launch. At a predetermined range, the booster is separated by thrust reversal and an expl bolt disconnect system. The depth bomb continues in the ballistic trajectory, steered by its tail-fins in accordance with instructions from the inertial guidance system. This determines the position and angle of the missile as it re-enters the water. A special mitigating device cushions the shock of water entry at supersonic speed; the depth bomb then sinks and explds

Principal characteristics of Subroc are length 20'6" (6.25m), max body diameter 1'9" (0.533m), launch wt, approx 4085 lbs (1853 kg), range 25–35 miles (40–56 km), and speed supersonic

Subroc became operational in 1965, and continues to arm high-speed nuclear attack submarines of the US Navy in world-wide service. Each ship carries 4 to 6 Subroc missiles

Refs: 1) M.J.H. Taylor & J.W.R. Taylor, "Missiles of the World", Charles Scribner's Sons, NY (1976), 142 2) R.T. Pretty, Ed, "Jane's Weapon Systems-1977", Franklin Watts, NY (1976), 131–32

Substitute Dynamite. A name improperly assigned during WWI to 40% Gelatin Dynamite which was replacing the 60% Gelatin Dynamite because of a shortage of NG

Ref: Naoúm, NG (1928), 331

Succinic Acid and Derivatives

Succinic Acid [Butanedioic acid, Amber acid, Ethylenesuccinic acid, Asuccin or Bernstein-säure (Ger)]. $\text{H.O(O):C.CH}_2\text{.CH}_2\text{.C(O):O.H}$; mw 118.09; odorless, monoclinic or triclinic crystals, v acid taste; mp 185° , $185\text{--}187^\circ$, 188° (separate values); bp 235° (partial conversion into the anhydride); d 1.56g/cc; RI 1.450. V sol in hot w, sol in acet, ethanol and eth; insol in benz. CA Registry Nr [110-15-6]. Occurs in nature in fossils, fungi, lichens, etc. Prepn is by reaction of hydrogen peroxide with acetic acid. The isothermal Q_c of succinic acid at 25° is $3023.1 \pm 0.3\text{ cal/g}$ (Ref 6)

In the study made by Pokhil & Romodanova (Ref 11) of the surface structure of burning proplnts contg a fuel and an oxidizer in which succinic acid is one of the fuels examined and Amm perchlorate, K perchlorate and Na perchlorate are the individual oxidizers, it was found that succinic acid burns in a stable manner with Amm perchlorate of 200–300 μm particle size at 1 atm press in air, and with K perchlorate or Na perchlorate of either 40–50 μm or 200–300 μm at 1 atm press in air. The authors conclude that the initial stage of burning of mixts contg a solid fuel such as succinic acid is carried

out in the reaction layer of the melt of the condensed phase with total positive thermal effect, and is completed by the formation of a stack gas mixt which burns in the zone above the surface of the mixts to the end products of burning

According to Sax (Ref 12) succinic acid has a min lethal dose for frogs of 2g/kg. It is used as a general purpose food additive and forms the expl derivatives shown below

Azido-iso-Succinic Acid [Azido-methyl-malonic acid or α -Azido-isobernsteinsäure (Ger)]. $\text{CH}_3\text{.C.N}_3\text{(CO}_2\text{H)}_2$; mw 159.10; N 26.42%; OB to CO_2 -65.37% ; v hydr prisms (from acetic acid + benz); mp 87.5° . V sol in acetic acid; sl sol in benz; insol in petr eth. Prepn is by heating bromomethylmalonic acid diethyl ester with Na azide dissolved in aq ethanol. Its Ag salt, **Silver Azido-iso-Succinic Acid**, colorl cryst, deton violently on heating (Refs 1, [272] & 4)

Azidosuccinic Acid Diazide [Triazosuccinic acid diazide or Azidobernsteinsäurediazide (Ger)]. $\text{N}_3\text{.CO.CH}_2\text{(N}_3\text{).CO.N}_3$; mw 209.16; N 60.28%; OB to CO_2 -57.37% ; sharp smelling yel oil. Prepn is by treating in the cold $\text{N,N}'$ -diisopropylideneazidosuccinic acid dihydrazide with nitrous acid. The Diazide deton violently on touching or on evapn of its soln (Refs 1, [271] & 5)

Iso-Succinic Acid Diazide [or Methylmalon-säurediazid (Ger)]. $\text{CH}_3\text{.CH(CO.N}_3\text{)}_2$; mw 168.14; N 33.33%; OB to CO_2 -76.13% ; clear oil. V sol in ethanol, eth and benz; insol in w. Prepn is by treating methylmalonic acid dihydrazide with fuming nitric acid. The Diazide explds when rubbed or warmed (Ref 1, [272])

Ethyldiazosuccinate. See in Vol 6, E225-R

Succinic Acid-Mono [3-Nitryloxy-2,2-Bis-Nitryloxymethyl-Propylester] (or 0-[3-Carboxy-propionyl]-0',0'',0'''-trinitro-pentaerythritol). $\text{C}_9\text{H}_{13}\text{N}_3\text{O}_{13}$; mw 371.25; N 11.32%; OB to CO_2 -49.65% ; cryst (from ethanol); mp $92\text{--}92.5^\circ$. Prepn is by warming succinic acid anhydride with 0,0',0''-Pentaerythritol Trinitrate (see in Vol 8, P84-R to 86-L) in acet. Its expl

properties were not investigated (Ref 1, (1920))

Succinic Acid-Bis-[3-Nitryloxy-2,2-Bis-Nitryloxy-methyl-Propyl Ester]. $C_{14}H_{20}N_6O_{22}$; mw 624.40; N 37.46%; OB to CO_2 -41.0%; mp 88-90°. Prepn is by warming succinyl chloride with 0,0',0''-Pentaerythritol Trinitrate in py. Its expl properties were not investigated (Ref 1, (1920))

Peroxy Succinic Acid. See in Vol 8, P214-L&R

Peroxy Succinic Acid Polymer. See in Vol 8, P218-L&R

Bis-Succinic Acid Trinitroethyl Ester (Bis-(Trinitroethyl) Succinate or BTNES). $(O_2N)_3C.CH_2.O.(O):C.CH_2.CH_2.C(:O).O.CH_2.C(NO_2)_3$; mw 340.06; N 24.72%; OB to CO_2 -18.82%; mp 125°; d 1.68g/cc. Prepn is by heating succinyl chloride with excess trinitroethanol at 75°; or from the acid chloride and trinitroethanol in the presence of Al chloride, or in the presence of other catalysts of the Friedel-Crafts type

BTNES has an ignition temp of 219°; the same impact sensy as Pentolite, RDX or Tetryl (Ref 8); an excellent storage stability based on the fact that no change in mp occurred after heating a sample of the ester for 6 months at 75° (Ref 8, p 13)

Accdg to Conn and Khalouf (Ref 9) the intravenous LD_{50} of BTNES in rabbits is 1.6 mg/kg and in mice 11.9mg/kg; the intraperitoneal LD_{50} in mice is 15.0mg/kg; the oral LD_{50} in rats is 224mg/kg

Succinimide (2,5-Dioxo-pyrrolidone, 2,5-Pyrrolidinedeone, Butanimide, 2,5-Diketopyrrolidone, 3,4-Dihydropyrrole-2,5-dione, Dihydro-3-pyrroline-2,5-dione, 2,5-Dioxopyrrolidine, Succinimide-sauba or Bernstein säureamid [Ger]. $C_4H_5NO_2$; mw 99.10; N 14.14%; orthorhombic bipyramidal cryst (from acet or ethanol); mp 125-27°; bp 287-89° (sl decompn); d 1.418g/cc. V sol in hot w; sol in w; insol in chl and eth. CA Registry Nr [123-56-8]. Prepn is by heating succinic acid in a stream of ammonia at 180°

The imide has a LD_{50} in rats of 14g/kg (Ref 14)

The Ag salt, **Silver Succinimide**, $AgC_4H_4NO_2$; mw 205.96; N 6.80%; OB to CO_2 -62.15%; ndles, explds when heated quickly (Ref 3, p 371)

Succinylazoimide. $C_2H_4(CO.N_3)_2$; mw 168.14; N 49.99%; OB to CO_2 -57.1%; long prismatic crystals; mp 30° (under w). V sol in ethanol; sl sol in eth; insol in w. Prepn is by gradually adding Na nitrite (2 moles) to a well-cooled, concd aq soln of succinyl hydrazine HCl and then shaking the mixt with eth. The imide explds when heated. (Refs 1, p 617 and [554] and 3a)

Dinitrososuccinyl dianilide (or Dinitrososuccin-dianilide). $C_{16}H_{16}N_4O_4$; mw 328.26; N 17.07%; OB to CO_2 -175.42%; yel cryst. Prepn is by passing NO fumes into 5g of succindianilide dissolved in 400cc of ethanol for 4.5 hrs at 15°. Yield is 5.5g. The dianilide explds at 111° (Ref 7)

4,5-Dinitro-Succinylfluorescein. $C_{16}H_{12}N_2O_{10}$; mw 392.30; N 7.14%; OB to CO_2 -114.20%; blue-yel prisms (from w); mp, the compd violently decomp over 300°. V sl sol in ethanol and acetic acid; mod sol in hot w; insol in benz and chl. Prepn is by reacting succinyl fluorescein with a mixt of both concd and fuming nitric acids at from -10° to 0° (Ref 2, [240])

4,5-Dinitro-Succinylfluorescein Diacetate. $C_{20}H_{14}N_2O_{11}$; mw 458.36; N 6.11%; OB to CO_2 -125.67%; crystals (from ethanol); mp, v vigorous decompn at about 200°. V sol in ethanol, acet and acetic acid; insol in benz and chl. Prepn is by reacting 2,4-dinitro-succinyl-fluorescein with an excess of ethanol at RT (Ref 2, [241])

2,4,5,7-Tetranitro-Succinylfluorescein. $C_{16}H_8N_4O_{13}$; mw 464.28; N 12.12%; OB to CO_2 -79.26%; citron-yel cryst (from ethanol); mp 203°. V sol in ethanol; mod sol in hot w, acetic acid and chl; v sl sol in benz. Prepn is by reacting fuming nitric acid with succinylfluorescein at 100°. The compd explds above its mp (Ref 2, [241])

2,4,5,7-Tetranitro-Succinylfluorescein-Diacetate. $C_{20}H_{12}N_4O_{15}$; mw 548.36; N 10.22%; OB to

CO₂ -119.53%; mp, explds above 350°. V sol in hot acet; sl sol in ethanol and acetic acid; insol in benz, chl_f, eth and xylol. Prepn is by esterification of 2,4,5,7-Tetranitro-Succinyl-fluorescein with a large excess of ethanol at RT (Ref 2, [241])

Refs: 1) Beil 2, 614 & 617, [266-272, 554], {1643}& (1908) 2) Ibid 19, [240, 241] 3) Ibid 21, 370-372 3a) T. Curtius, JPrakt-Chem 52, [2], 210-26 (1895) & Ibid, JCS 70, 35 (1896) 4) M.D. Forster & R. Müller, JCS 97 (I), 132 (1910) & CA 4, 1606 (1910) 5) T. Curtius & F. Hartman, Ber 45, 1055 (1912) & CA 6, 2433 (1912) 6) H.M. Huffman, "Thermal Data . . . The Heats of Combustion of . . . Succinic Acids . . .", JACS 60, 1172 (1938) & CA 32, 5690 (1938) 7) J.W. Haworth & D. Hey, "Nitrosoacylarylamines. II. The Action of Nitrous Fumes on Acylarylamines", JCS 1940, 361-69 & CA 34, 3699 (1940) 8) W.F. Sager & D.V. Sickman, "Second Report On Research and Development in New Chemical High Explosives", NAVORD 483 (1952), 13 9) K.W. Conn & H.C. Khalouf, "The Parenteral and Oral Toxicity of Nitroform and Certain New Explosives and Intermediates Derived From Nitroform", ChemCorpsMedical-Lab Rpt 236 (1954) 10) P. Tavernier & M. Lamouroux, MP 39, 349 & 355 (1957) & CA 54, 21974 (1960) 11) P.F. Pokhil & L.D. Romodanova, "Investigation of the Structure of Surface of Burning Model Mixtures of Solid Fuels", from "Heat and Mass Transfer (Selected Articles)", FTD-MT-24-248-67 (1967), 4 & 6 12) Sax (1975), 1129 13) Merck (1976), 1147 (No 8668) 14) Ibid, 1148 (No 8671)

Sugar Alcohols and Their Nitrated Derivatives

See in Vol 6, G84-R under "Glucosides, Nitration Studies . . .". The major ref of this entry; OSRD 147 (1941), entitled "The Preparation of Sugar Alcohols and Glucosides for Nitration Studies", designates eight sugar alcohols (or polyalcohols obt'd by hydrogenation of the appropriate sugar) that the author, Wolfrom, considered prime parent compds for expls: dulcitol, erythritol, fucitol, levoglucosan, mannitol, rhamnitol, sorbitol and xylitol. Since there

is very little in the way of OSRD reports on the continuation of this project, one must rely on the reported literature to find information on the expls which have been formed by nitration of these sugar alcohols. The appropriate sugar alcohols and their nitrated expl derivatives are presented below:

Dulcitol and Derivatives. See in Vol 5, D1567-R to D1568-L

Erythritol and Derivatives. See in Vol 5, E123-L to E125-L

Levoglucosan and Derivatives. See in Vol 6, G83-R under "Glucosan and Derivatives"

D-Mannitol and Derivatives. See in Vol 8, M13-L to M16-R

L-Rhamnitol [1-Desoxy-L-mannitol or Rhamnitol (Ger)]. C₆H₁₄O₅; mw 166.20; sweet tasting prisms (from acet); mp 121°, 123°, 123.5° (separate values); [α]_D²⁰ + 10.7° (8.648% aq soln). V sol in ethanol and w; sl sol in acet and chl_f; insol in eth. Prepn is by hydrogenation of L-rhamnose in w using Pt oxide or Raney Ni under press at 100°. Nitration of L-rhamnitol yields **Rhamnitol-pentanitate**. C₆H₉N₅O₁₅; mw 310.05; N 22.59%; OB to CO₂ -7.74%; white pasty mass. Sol in acet; sl sol in ethanol and eth

Ref: Beil 1, 532 and {2382}

D₂-Sorbitol and Derivatives. See in this Vol under "Sorbitol"

Xylitol (1,2,3,4,5-Pentanepentol). C₅H₁₂O₅; mw 152.17; white sweet-tasting solid, metastable rhomboids or stable monocl cryst (from ethanol); mp 61-61.5° (metastable form), 93-94.5° (stable form); bp 215-17° at 1 mm. V sol in w; sol in ethanol and py. Prepn is by redn (hydrogenation) of D-xylose either catalytically or by using Na amalgam or by an electrolytic process. Nitration of xylitol yields an expl syrup, **Xylitolpentanitate**. C₅H₇N₅O₁₅; mw 377.17; N 18.57%; OB to CO₂ +6.36%
Refs: 1) Beil 1, 513, [604] & {2379} 2) J.A. Monick, "Alcohols, Their Chemistry, Properties and Manufacture", Reinhold, NY (1968), 426-27

Sugars and Their Nitrated Derivatives

Sugars. According to The Condensed Chemical Dictionary (Ref 7), "... a carbohydrate ... product of photosynthesis comprised of one, two, or more saccharose groups ... (see below) ... the monosaccharide sugars (often called simple sugars) are composed of chains of from 2 to 7 carbon atoms. One of the carbons carries aldehydic or ketonic oxygen which may be combined in acetal or ketal forms. The remaining carbons usually have hydrogen atoms and hydroxyl groups. Chief among the monosaccharides are glucose (dextrose) and fructose (levulose). These are optical isomers of formula $C_6H_{10}O_5$, ie, their crystals have the property of rotating ... (polarized light) ... either left or right ... Hence the alternate names dextrose and levulose ...

Among the disaccharides are sucrose (cane or beet sugar); lactose, found in milk (qv); maltose, obtained by hydrolysis of starch (qv); and cellobiose from partial hydrolysis of cellulose (qv). High-polymer sugars occur as w-soluble gums such as arabic (qv), tragacanth, etc ... Hydrolysis of sucrose yields invert sugar, composed of equal parts fructose and glucose. If on a scale of relative sweetness, sucrose has an assigned value of 100, ten percent solns have the following values: fructose 120, glycerol 77, glucose 69, and lactose 39. Sugar is an important source of metabolic energy in foods, and its formation in plants is an essential factor in the life process ..."

The various sugars, such as sucrose, have been used as fuels in pyrots or expls (Ref 6). See under the individual entries below

Nitrated Sugars. Nitration of the various sugars has yielded expl products. Although several of the nitrated sugars; ie, Methyl- α -D-Glucopyranoside, Nitrohydrene and Sucrose Octanitrate, approach accepted military expls in brisance, it has been found that in almost all cases the stability of the nitrated sugar alone is not acceptable. Various stabilizing agents such as woodmeal, DPA, etc have been used to lengthen storage stability (Ref 5, p 446). However, a good reason for using various sugars as expl raw material is the lower cost as compared, for instance, to glycerine

The initial series of expts performed by chemists during the nineteenth century found that the nitration of sugars was not easy. The obtained prod was resinous, the residual nitrating acid was difficult to remove, and prod purification was laborious. The resulting prods were unstable and decompd readily. A more current group of scientists, Fleury, Brissaud and Lhoste (Refs 3 & 4) have evolved a procedure to obtain quantitative crystn prods without using mixed nitric and sulfuric acids. In this procedure the nitration of sugars can be carried out at a temp of about 0° by means of a mixt prepd from 2p anhyd nitric acid, 1 p acetic anhydride and 1 p acetic acid. Other experimenters have used more moderate nitrating reagents to achieve more easily controlled reactions. For example, Bell and Synge (Refs 1 & 2) nitrated methyl-4,6-O-ethylidene- β -D-glycoside using nitrogen pentoxide in chl f below 0° to produce the 2,3-dinitrate. However, if nitric acid is used in chl f, methyl β -D-glycoside 2,3,4,6-tetranitrate is the chief prod

The chemical properties of the sugar nitrates as a class can be found in Urbański (Ref 5, p 443-44)

The expl properties of the sugar nitrates derived from the individual sugars listed below are shown where available

Refs: 1) D.J. Bell & R.K.M. Synge, JCS **1937**, 1711 & CA **32**, 504 (1938) 2) Ibid, **1938**, 836 & CA **32**, 6627 (1938) 3) G. Fleury & L. Brissaud, CR **222**, 1051 (1946) & CA **40**, 5022 (1946) 4) G. Fleury et al, MP **31**, 107 (1949) & CA **46**, 11685 (1952) 5) Urbański **2** (1965), 439-46 6) Ellern, Pyrotechnics (1968) 7) CondChemDict (1976), 823-24

Cellobiose and Derivatives. Sec in Vol 2, C93-R to C94-L

Cellulose and Derivatives. See in Vol 2, C95-R to C125-R

Dextrin and Derivatives. See in Vol 5, D1113-R to D1115-R

Dextrose and Derivatives. See in Vol 5, D116-L & R

Whole
Page

Dimethylmethylgalactoside and Derivatives. See in Vol 5, D1349-L & R

Dimethylmethylglucoside and Derivatives. See in Vol 5, D1349-R to D1350-L

Ethyleneglycol-Sugar Mixture, Nitrated. See in Vol 6, E253-R

Ethyleneglycolglucoside and Derivatives. See in Vol 6, E256-R

Ethylglucopyranoside and Derivatives. See in Vol 6, E295L & R

4,6-Ethylidene-Methylglucosides and Derivatives. See in Vol 6, E304-R to E305-L

Fructosans and Derivatives. See in Vol 6, F207-R to F208-L

Fructose or Laevulose. See in Vol 6, F208-L

d-Galactose and Derivatives. See in Vol 6, G8-L

d- α -Glucosheptose and Derivative. See in Vol 6, G82-L

Glycopyranose and Derivatives. See in Vol 6, G83-L

Glucosan and Derivatives. See in Vol 6, G83-R

Glucose and Derivatives. See in Vol 6, G83-R

Glucose-Glycerol and Lactose-Glycerol Nitrates. See in Vol 6, G84-L

Glucosides and Glycosides. See in Vol 6, G84-R

Glucosides, Nitration Studies. See in Vol 6, G84-R

Gum-Sugar (Arabinose). See in Vol 6, G187-L

Hemicelluloses (or Semicelluloses). See in Vol 7, H60-R

Hydrocellulose and Hydrocellulose Nitrate. See in Vol 7, H213-L & R

Inulin and Inulin Trinitrate. See in Vol 7, I115-R to I116-L

Lactose and Derivatives. See in Vol 7, L1-R to L2-R

Maltose and Derivatives. See in Vol 8, M10-R to M11-L

D-Mannose and Derivative. See in Vol 8, M16-R to M17-L

Methyl Glucoside and Its Tetranitrate. See in Vol 8, M106-L & R

Mucic Acid Trinitrate. See in Vol 8, M160-R

Nitrostarch. See in Vol 8, N157-L to N162-R

Pectin Nitrates. See in Vol 8, P78-L & R

Rhamnose and Derivative. See under this title in this Vol

Saccharose and Derivatives. See below under "Sucrose and Nitrated Derivatives"

Sorbose (D) (Pseudotagatose or D-Sorbinose).

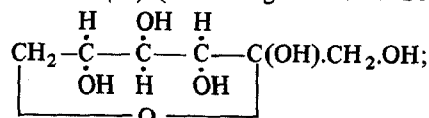

mw 180.16; white, crystn powdr, sweet taste; mp 159–161°, 165° (separate values); d 1.612 g/cc at 17°; $[\alpha]_D^{30}$ –42.7°. V sol in w; sl sol in ethyl or isopropyl alc; insol in eth, acet, benz and chl. Prepn is by aerobic fermentation of sorbitol using *Acetobacter suboxydans*. CA Registry No [87-79-6]. D-sorbinose is combustible. It is used in the mfg of vitamin C (ascorbic acid). The compd is the parent of the trinitrate below

Refs: 1) Beil 31, 345 2) Merck (1976), 1127 (No 8498) 3) CondChemDict (1977), 807

Sorbosan Trinitrate. $\text{C}_6\text{H}_7\text{O}_5(\text{NO}_2)_3$; mw 297.13; N 14.14%; OB to CO_2 –24.23%; cryst; mp 40–54°. Sol in ethanol. Prepn is by soln of sorbose in cold (0°) nitric acid followed by pouring the soln into well stirred sulfuric acid also at 0°. The prod is then pptd, filtered off,

ice w washed and recryst from ethanol. The 100° thermal stability of the trinitrate constitutes a loss of less than 1% during 20 hrs. The compd is an expl

Refs: 1) Beil 31, 347 2) Urbański 2 (1965), 439 & 441

Sucrose and Nitrated Derivatives

Sucrose (Cane Sugar, Beet sugar, Saccharose or [α -d-Glucosido]- β -d-fructofuranoside).

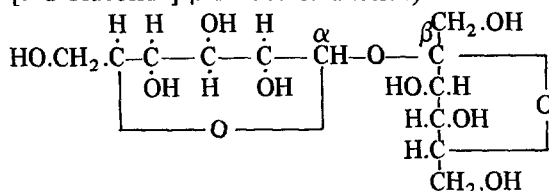

mw 342.30; colorl monoclinic sphenoidal crystals, sweet taste, odorless; mp 160–86°, 185–86° (decompn); d 1.5917g/cc at 25/25°; $[\alpha]_D^{20}$ +66.5°; RI 1.5376. Sol in ethanol, py and w. Prepn is by crushing and extrn of sugar cane with w or extrn of the sugar beet with w, then evapn of the w followed by prod purification using lime, carbon and various liqs. Sucrose also occurs in sorghum, honey and maple sap. CA Registry No [57-50-1]. Sucrose is combustible, with a Q_c of 1351.3kcal/mole (Ref 3b) and is used as a fuel in expl compns such as the following: Gray (Ref 2) invented an expl consisting of 60–40% granular sugar and 40–60% granular K chlorate bonded into grains with a small amt of gum arabic which also coated the grains. A similar expl was invented by Griffing (Ref 3) who combined K chlorate 40 and sucrose 35p with coal 10, Mn dioxide 10 and sugar of milk 5p. Crane et al (Ref 4) developed an expelling system compn for the M8 Practice Anti-personnel Mine consisting of 40% 1-methyl-amino anthraquinone, 40% K chlorate and 20% sucrose. This mixt has a calc Q_R of 735cal/g, a theoretical d of 1.68g/cc, an oxidant to fuel ratio of 2.0 and an estimated adiabatic flame temp of 1450°K

According to Ellern (Ref 6) (cane) sugar has more than several applications in pyrots. When used with chlorates it makes up a primer compn (Ref 6, pp 48 & 55), with various oxidizers an incendiary compn (Ref 6, p 153), it serves as a preservative-fuel for charges disbursing tear gas from grenades (Ref 6, p 161), with Na ni-

trate in the burning portion of a self-vulcanizing tire patch (Ref 6, p 226), as the fuel in smoke generating mixts (Ref 6, p 288), and as a general, all purpose fuel (Ref 6, p 325)

Sucrose is also the parent compd of **Nitrohydrene**. See under this title in Vol 8, N134-R. Addnl data on this compd, presented from Urbański (Ref 5, p 445–46) is as follows:

“... (it) has an appreciably higher viscosity than nitroglycerine itself, hence its stabilization washing is considerably more difficult. Nitrohydrene is particularly inclined to form a water emulsion. To cause it to separate more completely from water after being washed in sodium carbonate solution, Nitrohydrene is treated with a sodium chloride solution. The composition of Nitrohydrene differs slightly from that of the original mixture. Nitrohydrene 80/20 obtained by nitrating a mixt consisting of 80% of glycerine and 20% of saccharose contains 86% of nitroglycerine and 14% of nitrosaccharose. In Nitrohydrene 75/25, 82% of nitroglycerine and 18% of nitrosaccharose are present

The stability of Nitrohydrene is significantly worse than that of nitroglycerine. The higher the nitrosaccharose percentage in the mixt, the lower its stability. According to Naoúm (Ref 3a) wood meal admixed with Dynamite may act as a stabilizer, because it absorbs the impurities or decompn products and can enter into reaction with these compds, thus removing them. With the aim of improving storage life, 0.1–0.2% of diphenylamine is also added to act as a stabilizer. A mixture prepared in this way can be kept for 75 days at 55° or for 8 years at 20° with no sign of decomposition

Naoúm has determined the values of the lead block expansion as follows:

Nitroglycerine	550cm ³
Nitrohydrene 80/20	550cm ³
Nitrohydrene 75/25	515cm ³ . . .”

The other nitrated sucrose compd of interest is **Sucrose Octanitrate** which is presented below

The USA military specification requirements (Ref 8) for “Sugar, Refined and Brown: Beet or Cane” is presented in Table 1

Table 1
USA Military Specification Requirements for "Sugar, Refined and Brown: Beet or Cane"

Requirement	Class	Type I ⁻¹				Type II ⁻¹		
		(a) ⁻²	(b) ⁻³	(c) ⁻⁴	(d) ⁻⁵	(a) ⁻⁶	(b) ⁻⁷	(c) ⁻⁸
Sucrose ⁻⁹		99.5% min	99.5% min	99.5% min	96.5% min	87% min to 94% max	84.5% min 93% max	82% min to 92% max
Ash ⁻¹⁰		0.04% max	0.04% max	0.05% max	0.05% max	2.25% max	3.25% max	3.25% max
Moisture ⁻¹¹		0.07% max	0.10% max	0.30% max	0.80% max	4.25% max	4.50% max	4.50% max
Particle size ⁻¹²		No 20 sieve (850 μm), 4% max on sieve; 1% max on sieve;	No 40 sieve (425 μm), 1% max on sieve;	---	No 100 sieve, 2% max on sieve;	(Footnote 13)	(Footnote 13)	(Footnote 13)
		No 100 sieve (150 μm), 8% max on sieve	No 140 sieve (106 μm), 80% min on sieve	---	No 200 sieve (75 μm), 25% max on sieve			
Weight, g		---	---	Tablet 4.5 Cube, 3.7	---	---	---	---
Color Reflectance ⁻¹⁴		---	---	---	---	34% min to 50% max	34% min to 40% max	18% min to 34% max

Footnotes to Table

- 1—All materials to be obtd from sugar and sugar beets
- 2—Granulated sugar (fine or extra fine)
- 3—Granulated sugar (super fine)
- 4—Tablet or cube sugar
- 5—Powdered or confectioners
- 6—Light brown sugar
- 7—Medium brown sugar
- 8—Dark brown sugar

- 9—By polarization measurement using a saccharimeter (Ref 6a)
- 10—By weighing before and after ignition
- 11—By weighing before and after vacuum drying
- 12—By shaking a 100g sample thru a nest of appropriate US sieves and weighing the residue remaining on each sieve
- 13—Prod shall have lumps of 1/2 inch max size; easily broken by light finger press
- 14—By using a Brice-Keane sugar photometer or a Beckman spectrophotometer at 590 nanometers

Refs: 1) Beil **31**, (424) 2) L. Gray, USP 975030 (1911) & CA **5**, 786 (1911)
 3) C.E. Griffing, USP 979476 (1911) & CA **5**, 993 (1911) 3a) Naoum, NG (1926)
 3b) Anon, EngDes Hdbk, "Military Pyrotechnic Series Part Three—Properties of Materials Used In Pyrotechnic Compositions", AMCP **706-187** (Oct 1963), 291–93 4) E.D. Crane et al, "Development of a Safe Expelling System for the M8 Practice Antipersonnel Mine", PATR **3392** (1966) 5) Urbański **2**, 440; 445–46
 6) Ellem, "Pyrotechnics" (1968) 6a) W.F. Pickering, "Modern Analytical Chemistry", Dekker, NY (1971), 241 7) Hackh's (1972), 644 8) Anon, "Sugar, Refined and Brown: Beet or Cane", USA Mil Spec **JJJ-S-791L** (10 June 1974) 9) N.L. Allinger et al, "Organic Chemistry", Second Edn, Worth, NY (1976), 679–80 10) Merck (1976), 1149–50 (No 8681) 11) CondChemDict (1977), 823
 12) ChemRubHdb (1978), C-503 & F-158
Addnl (Limited Distribution) Ref: J.H. Agosti & R.A. Williams, "Process Studies for CBI Propellant", Final Report on Project **PE-193**, Hercules Inc, Radford (1970)

Sucrose Octanitrate (Saccharose Octanitrate).

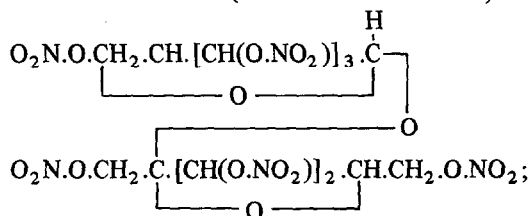

mw ($\text{C}_{12}\text{H}_{14}\text{O}_{27}\text{N}_8$) 702.28; N 15.96%; OB to CO_2 -9.11%; colorl orthorhombic or monoclinic cryst; mp 85.5° ; d (sp gr) 1.67g/cc; $[\alpha]_D^{20}$ +56.05°. V sol in eth, methanol and nitrobenz; sl sol in benz; v sl sol in ethanol; insol in petr eth. Prepn is by nitration with a mixt of nitric and sulfuric acids at 0° in the presence of a mixt of other compds consisting mainly of an alkyl ester of a hydroxy aliphatic carboxylic acid, the alkyl group of which contains not more than five C atoms (such as nitrated ethyl or butyl lactate) together with amyl nitrate and dichloroethyl ether. The octanitrate is crystd at about 80° . Recrystn is from methanol (Refs 2 thru 7)

Sucrose Octanitrate is extremely sensitive to heat and friction (Ref 9). It has an expln temp of (puffs off at) $167-70^\circ$; a Q_e of 1289.3kcal/mole;

a Q_e of 950cal/kg (Ref H_2O , X), a F_f^V of 317.3 kcal/mole (Ref 11); impact sensy using a 2kg wt is 30cm; power by Trauzl test is 296cc (avg) (Ref 9)
 Refs: 1) Beil **31**, (424) 2) E.J. Hoffman & V.P. Halse, "The Nitration of Sucrose: Sucrose Octanitrate", JACS **41**, 235–47 (1919) & CA **13**, 1850 (1919) 3) J.A. Wyler, "Sucrose Octanitrate", USP 2081161 (1937) & CA **31**, 5165 (1937) 4) Ibid, "Nitrating Sugars and Their Glycosides", USP 2094693 (1937) & CA **31**, 8547 (1937) 5) Ibid, "Nitrating Sucrose", USP 2101927 (1938) & CA **32**, 958 (1938) 6) Ibid, "Sucrose Octanitrate", USP 2105390 (1938) & CA **32**, 2357 (1938) 7) Ibid, "Melting and Purifying Sucrose Octanitrate", USP 2165435 (1939) & CA **33**, 8214 (1939)
 8) Blatt, OSRD **1085** (1942), 78 9) Ibid, OSRD **2014** (1944) 10) P. Lhoste, "Le Nitrate De Sacchróse . . .", MP **39**, 191–93 (1957) & CA **52**, 21107 (1958) 11) L. Médard & M. Thomas, "Chaleur De Combustion De Onze Substances Explosives", MP **39**, 200–07 (1957) & CA **53**, 718 (1959)

Synanthrose and Its Nitrated Derivative

Synanthrose. $\text{C}_{12}\text{H}_{22}\text{O}_{11}$; mw 342.34; amorph, brn-yel mass; mp $140-45^\circ$ (decompn). Sol in aq ethanol and w; sl sol in ethanol; insol in eth. Prepn is by alcoholic extrn of the root bulbs of the Synanthercae. The nitrated prod of synanthrose is an expl and is presented below

Refs: 1) Beil, not found 2) O. Popp, Ann **156**, 181–90 (1870) & CA, not found

Nitrosynanthrose. Sol in ethanol; sl sol in w. Prepn is by nitration of synanthrose using a mixed acid consisting of 1 p concd nitric and 2 to 2.5p of concd sulfuric acid. The nitrated prod is pptd in cold w and recryst from ethanol. Nitrosynanthrose is an expl which burns when ignited in the open

Refs: 1) Beil, not found 2) O. Popp, Ann **156**, 181–90 (1870) & CA, not found

Xylose and Its Nitrated Derivative

D-Xylose (Wood sugar).

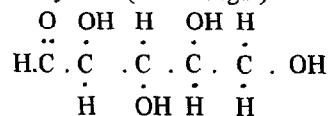

mw 150.13; white, monoclinic ndles, sweet taste; mp 144–45°, 153–54° (sep values); d 1.525g/cc at 20/4°. V sol in eth and w; sol in hot ethanol. Found in wood, corn cobs, peanut shells and cottonseed hulls. Xylose is isolated from these natural sources by boiling with 8% sulfuric acid. CA Registry No [58-86-6]. It is combustible and is the parent compd for the nitrated compd, the Tetranitrate, entered below

Refs: 1) Beil 1, 865, 868, (437) & (4223)
2) Beil 31, 47 & 55 3) Merck (1976), 1301 (No 9749) 4) CondChemDict (1977), 932
 α -d-Xylopyranose Tetranitrate.

$C_5H_6O(ONO_2)_4$; mw 330.15; N 16.97%; OB to CO_2 0%; cryst; mp 72.5°; d 1.7g/cc +124°10' (4% soln in acet). Sol in acf, ethanol and eth. Prepn is by nitration of d-xylose at 0° with constant stirring using an acid mixt consisting of 2p of 100% nitric acid, 1 p of acetic anhydride and 1 p of ethanol. The prod is recryst from methanol. The yield is quant. CA Registry No [26469-37-4]. The tetranitrate has an expln temp of 250°. When heated to 100° the compd loses 60% of its wt within 10 hrs

Nitrated xylose has been used in expls such as that of Norton (Ref 2) which consisted of NG 60–80 and nitrated xylose 20–40%, with or without addnl ingredients

Refs: 1) Beil, not found 2) S.G. Norton, USP 1466147 (1923) & CA 17, 3791 (1923)
3) G. Fleury et al, CR 224, 1016–18 (1947) & CA 43, 5007 (1949) 4) Ibid, MP 31, 107–20 (1949) & CA 46, 11685 (1952)
5) Urbański 2 (1965), 440–41

Sugar Dusts, Explosive Properties of. See in Vol 5, D1578-R to D1579-L under “Dust, Explosibility of” and “Dust Explosions”; also, in Vol 4, D253-L to D255-R under “Detonation and Explosion of Dusts, Mists and Vapors”

Sulfanilic Acid and Derivatives

Sulfanilic Acid (4-Aminobenzenesulfonic acid or p-Anilinesulfonic acid). $C_6H_7NO_3S$; mw 173.84; N 8.09%; OB to CO_2 –115.05%; monohydrate

has orthorhombic plates (from w); v slow crystn can yield the dihydrate; both become anhydr at around 100°; mp 288°, > 360° (decompn) (separate values). Slowly sol in w; sl sol in hot methanol; insol in benz, ethanol and eth. CA Registry No [121-57-3]. Prepn is by reacting aniline with weak fuming sulfuric acid and pouring the reaction product into w. The Na salt dihydrate; **Sodium Sulfanilic Acid Dihydrate**, $C_6H_6NNaO_3S \cdot 2H_2O$; orthorhombic, bipyramidal plates; freely sol in w; sol in hot methanol; is suggested as a component of expl compns along with such oxidizing agents as nitro compds in Ehrlich's patent (Ref 2)

Refs: 1) Beil 14, 695, (720) & [1436]
2) J. Ehrlich, “Explosive”, USP 1550064 (1925) & CA 19, 3595 (1925) 3) Merck (1976), 1157 (No 8734)

Sulfanilic Acid Azide. $H_2N \cdot C_6H_4 \cdot SO_2 \cdot N_3$; mw 198.22; N 28.27%; OB to CO_2 –104.43%; yel plates; mp 36°. V sl sol in ethanol and eth; sparingly sol in benz and chl. Prepn is by heating for a short time a mixt of N-acetyl sulfanilic acid azide with dil HCl. The azide deflagrates when heated on a spatula
Ref: Beil 14, [437]

N-Acetyl Sulfanilic Acid Azide. $C_8H_8N_4SO_3$; mw 240.26; N 23.32%; OB to CO_2 –113.21%; ndles (from benz); mp 107°. V sl sol in HCl, cold ethanol and cold eth, and in warm chl and warm benz; insol in ligr and w. Prepn is by reacting N-acetyl sulfanilic acid with Na azide in aq ethanol. The azide deflagrates when heated on a spatula
Ref: Beil 14, [439]

Sulfanilic Acid Hydrazide. $H_2N \cdot C_6H_4 \cdot SO_2 \cdot NH \cdot NH$; mw 186.23; N 22.57%; OB to CO_2 –120.28%; colorl prisms (from dil ethanol); mp 131°. V sol in hot w, dil acids and dil alkalis. Prepn is by heating a mixt of N-acetyl sulfanilic acid hydrazide with dil HCl on a w bath for a short time. Slow or cautious heating of the hydrazide causes gaseous emissions, while continued heating results in deflagration
Ref: Beil 14, [437]

3,5-Dinitro-Sulfanilic Acid (3,5-Dinitro-4-aminobenzol-sulfonic acid-(1) or 2,6-Dinitro-aniline-

sulfonic acid-(4)] . $C_6H_5N_3SO_7$; mw 263.20. Prepn is by heating 2,6-dinitro aniline with sulfuric acid. The K salt, **Potassium-3,5-Dinitro-4-Amino Benzol Sulfonate**; $KC_6H_4N_3SO_7$; mw 301.29; N 13.95%; OB to CO_2 -37.17%; v sl sol in w; sl sol in acet and ethanol, deflagrates on heating
 Ref: Beil 14, 710

Sulfates

Either acid or neutral salts of sulfuric acid. The acid salts may be dehydrated to form the pyrosulfates such as

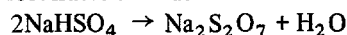

The normal salts of the alkali and alkaline earth metals and Pb do not readily decompose upon heating, but the sulfates of the nobler metals evolve sulfur trioxide or sulfur dioxide and O_2 if the decompn temp is high (Ref 1)

The patent of Gruaz (Ref 2) suggests that a small amt of a metal sulfate added to a phosphorous-based expl will reduce the amt of deflagration of the expl

Sulfates which have been found useful in Ordn are presented next

Refs: 1) W. Latimer & J. Hildebrand, "Reference Book of Inorganic Chemistry", Macmillan, NY (1947), 250-51 2) E. Grauz, FrP 2109360 (1972) & CA 78, 99988 (1973)

Ammonium Sulfate. $(NH_4)_2SO_4$; mw 132.14; N 21.2%; odorless, orthorhombic cryst or white granules; mp 280° (decompn); d 1.77g/cc. Sol in w; insol in acet and ethanol. CA Registry No [7783-20-2]. Prepn is by reacting ammonia with sulfuric acid

The only Ordn use found for amm sulfate is described in Vol 7, J56-R under the "Type 4 Mk3, K3" expls used by the Japanese Navy during WWII

Refs: 1) Gmelin, Syst Nr 23 (1936), 261-80 2) Merck (1976), 76 (No 586)

Barium Sulfate (Blanc fixe, Actybaryte, Bakontal, Baridol, Citobaryium, Neobar or Unibaryt). $BaSO_4$; mw 233.43; fine, heavy, odorless powdr or polymorphous cryst; mp 1600° (decompn); d 4.25-4.58g/cc. Sol in hot concd sulfuric acid;

insol in w. CA Registry No [7727-43-7]. Occurs in nature as the mineral barite, also as barytes and heavy spar. Prepn is by adding sulfuric acid to the aq extract of BaS

The only use as an energetic matl in Ordn for Ba sulfate is in pyrots which is noted in Vol 2, B21-R. Another Ordn use is in the formulation of inert ammo fillers (Ref 3).

It is also claimed to be useful as a proplnt additive for the reduction of gun wear. See in Vol 8, P419-L & R under "Additives for reduction of gun wear"

Refs: 1) Gmelin, Syst Nr 30 (1932), 262-67 2) Ibid (1960), 182-86 & 412-14 3) Anon, "Barium Sulfate", MIL-B-48177 (March 1973)

Potassium Sulfate (Sal polychrestum, Arcanum duplicatum or Tartarus vitriolatus). K_2SO_4 ; mw 174.26; colorl, odorless, hard, bitter tasting cryst; mp 1067° ; d 2.66g/cc. Sol in w; insol in ethanol. CA Registry No [7778-80-5]. Prepn is by reacting K hydroxide with sulfuric acid (Ref 12)

Sax (Ref 10) considers the sulfate as a moderate local irritant, a highly toxic systemic poison by ingestion and a dangerous disaster hazard if heated to decompn

The principal Ordn use for K sulfate is in small (ca 1%) addns to solid proplnts for the purpose of suppressing both flash and smoke during combustion. See in Vol 8, P406-R and P407 (tables) under "Propellants, Solid" and the following PATR's; 1336, 1479, 1541, 1583, 1662, 1674, 1883 and 2347 (Refs 2 thru 9)

The USA military specification for K sulfate is MIL-P-193A with amendment 2 (Ref 11)

Refs: 1) Gmelin, Syst Nr 22, Sect 3 (1937), 708-40 2) W.H. Rinkenbach, "Thermochemical and Physical Tests of Nitroguanidine Powders", PATR 1336 (1943) 3) R.D. Sheeline, "Develop Flashless Powder For the 90mm Gun", PATR 1479 (1944) 4) G. Weingarten, Ibid, PATR 1541 (1945) 5) R.W. Scharf, "Development of a Method to Evaluate Smoke from Propellants", PATR 1583 (1945) 6) S. Weisberger, "Chromatographic-Spectrophotometric . . .", PATR 1662 (1947) 7) W.H. Rinkenbach, "Study of Stability of Double-Base Propellants", PATR 1674 (1948) 8) J.W. Lavitt & C.B. Finkel, "The Determination of Potassium Sulfate in M10 Propellant . . .",

PATR 1883 (1952) 9) H.L. Herman, "Non-Aqueous Titration Method for the Determination of Potassium Sulfate in Propellants", PATR 2347 (1956) 10) Sax (1968), 1051
 11) Anon, "Potassium Sulfate (for Ordnance Use)", MIL-P-193A with Amendment 2 (Sept 1974) 12) Merck (1976), 994 (No 7463)

Sulfide(s)

The ion S^{2-} . The divalent negative sulfur atom in sulfides is usually part of an element – or organic radical – sulfur molecule. Examples of sulfide compds useful in Ordn are presented below

Ref: Hackh's (1972), 645-R

Antimony Sulfide (Antimony trisulfide, Antimonous sulfide, Needle antimony or Antimony glance). Sb_2S_3 ; mw 339.72; grey, lustrous cryst masses or greyish-blk powd, also yel-red, amorph solid; mp 550° ; bp ca 1150° ; d 4.64g/cc (blk cryst), 4.12 g/cc (yel-red solid). Sol in ethanol, amm mercaptan, K sulfide, concd hydrochloric acid (with evoln of H_2S), and fixed alkali hydroxides; v sl sol in w; insol in acetic acid. CA Registry No [1345-04-6]. The greyish-blk form occurs in nature as the mineral stibnite. Prepn of the yel-red or orn-red form is by passing hydrogen sulfide gas into acid solns of the trichloride or the antimonites. The ppt formed is filtered, dried and ground (Refs 1, 9, 10 and 11). The sulfide heats spontaneously at the rate of $0.0015^\circ/hr/g$ (Ref 5)

Sb trisulfide has an intraperitoneal lethal dose in rats of 1.0g/kg (Ref 9) and a (human) toxic tolerance of 0.5mg/cm of air (Ref 10). According to Sax (Ref 7) the sulfide presents a dangerous hazard when heated to decompn or in contact with acids or acid fumes, as it emits highly toxic fumes of the oxides of S or Sb. When the sulfide is reacted with w or steam it produces toxic and flammable vapors, and in contact with strong oxidizing matls it reacts in a vigorous exothermic manner. It can also spontaneously react with chlorates and perchlorates with a moderate risk of expln

The patent of Tagliabue (Ref 2) claims that an expl is formed if Sb trisulfide (20–50p) is

incorporated with Na nitrate (40–70p) and coal (10–15p). Naoúm (Ref 2a) reports the inclusion of 3% of the sulfide in the oldest non-NG plastic expl, **Kinetite**. Information on this expl can be found in Vol 7, K13-L. The sulfide was also used in the Japanese Army WWII ammo primers shown in Vol 7, J14-L under "Bakufun". Bain (Refs 3 & 4) developed expl primers using the sulfide (25%) as a fuel with K chlorate (25), glass (35), LA (13) and shellac (2%). For a comprehensive look at Sb sulfide in primers see in Vol 8, P373-L to P375-L under "Mechanical Initiators–Percussion Primers, Stab Detonators and Friction Primers"

For the use of Sb sulfide in pyrots, see in Vol 8, P516-R under "...7) Igniters and Initiators". Addnl information is to be found in Ellern (Ref 6) who reports on a safety match formulation contg dextrin (20), K chlorate (50) and Sb sulfide (30%) (Ref 6, p 355), and a safety match striker formulation contg animal glue (9.3), dextrin (7.0), red P (37.2), Sb sulfide (33.5), Fe oxide (7.0) and Mn dioxide (3.4%) (Ref 6, p 356)

The USA Mil Spec (Ref 8) contains the following requirements for Type I (0.2% free S, max) and Type II (0.02% free S, max) Antimony sulfide.

(1) "... Antimony sulfide shall be either natural or synthetic ..."

(2) "... The product shall have the characteristic shining, needlelike structure, steel-grey color, and hardness of the naturally occurring crystalline mineral. The lump form of the antimony sulfide shall be clean and free from adherent gangue material or scale. Pulverized antimony sulfide shall be free from extraneous material as indicated by visual examination under a magnification that clearly shows the crystal structure. The manufacturer shall certify that the product has these physical characteristics ..."

(3) "... Antimony sulfide shall comply with the chemical requirements specified in Table I ..."

Table I
Chemical Requirements

	Type I percent	Type II percent
Antimony, min ^a	70.5	70.5
Total sulfur, min ^b	24.8	24.8
Insoluble material, max ^c	1.0	1.0
Acidity, max ^d	0.01	0.01
Lead, max ^e	0.15	0.15
Iron, max ^f	0.5	0.5
Free sulfur, max ^g	0.2	0.02
Arsenic, max ^h	0.06	0.06
Moisture, max ⁱ	0.20	0.20

Footnotes to Table I:

- a—by redox titrimetry of the trivalent Sb using 0.05N K permanganate to a pink end pt
 b—gravimetrically as Ba sulfate
 c—gravimetrically after acid digestion to eliminate the S as hydrogen sulfide and Sb as the w sol nitrate
 d—by acid-base titrimetry of the hot w digestion filtrate using 0.01N K hydroxide to a methyl orange end pt
 e—gravimetrically as Pb sulfate
 f—spectrophotometrically at 500nm by the development of the phenanthroline orange-red Fe complex

g—gravimetrically after methylene chloride extrn for 4 hrs in a Soxhlet app

h—spectrophotometrically at 660nm after development of the As ammonium molybdate heteropoly blue complex

i—gravimetrically by loss-in-wt after heating a sample for 2 hrs at 105° and then cooling in a desiccator

(4) “. . . Antimony sulfide shall comply with the granulation requirements specified in Table II
Refs: 1) Gmelin, Syst Nr 18, Teil B (1949), 503–24 2) J. Tagliabue, BritP 236413 (1924) & CA 20, 990 (1926) 2a) Naoúm, NG (1928), 353 3) C.J. Bain, “Investigation of Lead Azide as a Substitute for Fulminate in Wet Loaded Primer Mixtures”, PATR 550 (1934) 4) Ibid, “Study of Lead Azide Primer Mixtures”, PATR 866 (1938) 5) M. Taźniewski, “Microcalorimetric Studies in the Domain of Abnormal Heat Effects”, RocznikiChem 18, 691–96 (1938) & CA 33, 4118 (1939) 6) Ellern, “Pyrotechnics” (1968), 54, 77, 217, 355 & 356 7) Sax (1968), 431 8) Anon, “Antimony Sulfide (For Use in Ammunition)”, MIL-A-159D (May 1972) 9) Merck (1976), 97 (No 751) 10) CondChemDict (1977), 69 11) ChemRub-Hdbk (1978), B-91

Table II
Granulation Requirements

	Class 1		Class 2		Class 3		Class 4		Class 5	
	min %	max %	min %	max %	min %	max %	min %	max %	min %	max %
Thru No 100 (150 μ m)	95	--	--	--	95	--	--	--	--	--
Retained on No 140 (106 μ m)	30	50	--	--	70	--	--	--	--	--
Thru No 140	--	--	97	--	--	--	--	--	99.0	--
Retained on No 200 (75 μ m)	--	--	80	95	--	--	--	--	95.0	--
Thru No 200	20	30	--	--	--	20	--	--	--	--

Footnote to Table II:

“. . . the specified sieve or sieves shall be nested on a bottom pan. A weighed portion of 100 grams of the sample shall be placed on the upper sieve. This shall be covered and shaken for 10 minutes by hand or for 5 minutes by means of a mechanical shaker geared to produce 300 plus or minus 15 gyrations and 150 plus or minus 10 taps of the striker per minute. The amounts retained on the sieves and the bottom pan shall be weighed and the percentage calculated . . .”

Arsenic Sulfide (Arsenic bisulfide, Arsenic disulfide, Realger, Red orpiment, Ruby arsenic or Red arsenic glass). As_2S_2 or As_4S_4 (from vap d measurements); mw 213.97 or 427.94; deep red, lustrous monoclinic cryst (α and β forms); mp, α (transition) at 267° and β , at 307° ; bp 565° ; d α , 3.506g/cc at 19° and β , 3.254g/cc at 19° ; RI 2.46, 2.59, 2.61 (separate values). Sol in alkali hydroxides; v sl sol in hot C disulfide and in benz; v v sl sol in w. CA Registry No [1303-32-8]. Prepn is by fusing together equimolar amts of As and S in a thick-walled, sealed tube at $500\text{--}600^\circ$ under a N_2 atm. The prod is purified by vac sublimation

Sax (Ref 4) considers the disulfide a dangerous disaster hazard as it can react vigorously with oxidizing mats, and the resulting oxides of both S and As are toxic

According to Ellern (Ref 3, p 135) the sulfide ("... red orpiment...") is included in a marine handlight pyrot compn called "... ships blue lights..." along with K nitrate and S. Generally, either a blue fire or an intense white flame results from incorporation of the disulfide into pyrots (Ref 5)

The USA Mil Spec for Arsenic Disulfide is **JAN-A-672** (Ref 1a)

Refs: 1) Gmelin, Syst Nr **17** (1952), 415-33 1a) Anon, "Arsenic Disulfide (For Use in Ammunition)", **JAN-A-672** (1948-49) 2) G. Brauer, Ed, "Handbook of Preparative Inorganic Chemistry", Vol **1**, 2nd Edn, Academic Press, NY (1963), 603 3) Ellern, "Pyrotechnics" (1968), 135 4) Sax (1968), 436 5) Merck (1976), 107 (No 822) 6) ChemRubHdbk (1978), B-91

Arsenic Trisulfide (Yellow arsenic sulfide, Orpiment, Auripigment, Arsenic yellow, King's yellow or King's gold). As_2S_3 ; mw 246.04; yel or red monoclinic cryst; mp 300° ; bp 707° ; d 3.43g/cc; RI 2.4, 2.81, 3.02 (separate values). Sol in alkalis, alkali sulfides or carbonates; slowly sol in hot HCl; v v v sl sol in w. CA Registry No [1303-33-9]. Prepn is by boiling diarsenic pentasulfide in w

Sax (Ref 4) considers the trisulfide's hazard rating and toxicity to be the same as that of arsenic disulfide (qv)

The trisulfide was used during WWII by the Japanese in fuze and pyrot primers. See in Vol 7, J46-L under "Raibun (Enka)"

The USA Military Specification for Arsenic Trisulfide is **JAN-A-623** (Ref 2)

Refs: 1) Gmelin, Syst Nr **17** (1952), 422-23 2) Anon, "Arsenic Trisulfide (For Use in Ammunition)", **JAN-A-623** (1948) 3) G. Brauer, Ed, "Handbook of Preparative Inorganic Chemistry", Vol **1**, 2nd Edn, Academic Press, NY (1963), 603 4) Sax (1968), 438 5) Merck (1976), 108 (No 834) 6) ChemRubHdbk (1978), B-92

Calcium Sulfide (Crude CaS is called Sulfurated lime, Calcic liver of sulfur, Liver of lime, Hepar calcis or Oldhamite). CaS ; mw 72.14; colorl cub cryst; the crude material is yel to pale grey; odor of H_2S in moist air; unpleasant alkaline taste; mp $> 2000^\circ$ (decompn); d 2.5g/cc; RI 2.137. V sol in solns of amm salts; sol in hot w with partial decompn; sl sol in cold w; insol in ethanol. CA Registry No [20548-54-3]. Prepn is by heating pure $CaCO_3$ in a stream of H_2S+H_2 at 1000°

According to Mellor (Ref 2) the sulfide reacts vigorously with chromyl chloride and Pb di-oxide and explosively with K nitrate

Refs: 1) Gmelin, Syst Nr **28**, Teil B2 (1957), 636-47 2) Mellor, Vol **3** (1941), 745 3) G. Brauer, Ed, "Handbook of Preparative Inorganic Chemistry", Vol **1**, 2nd Edn, Academic Press, NY (1963), 938 4) Merck (1976), 216 (No 1710) 5) ChemRubHdbk (1978), B-101

Hydrogen Sulfide. See Vol 7, H222-R and the following *Addnl Refs*: 1) Gmelin, Syst Nr **9**, Teil B2 (1960), 523-32 2) Mellor, Vol **10** (1947), 141 [In the presence of air, contact with mixts of Ca or Ba oxide with Hg or Ni oxide may cause vivid incandescence or expln]

Hydrogen Trisulfide (or Trisulfane). H_2S_3 ; mw 98.21; bright yel oil liq, pungent odor of camphor; mp -52 to -54° ; bp 90° (decompn to H_2S and S), $43\text{--}50^\circ$ at 4.5mm; d 1.496g/cc at 15° ; RI 1.705 at 15° . Sol in benz, carbon disulfide, chl, eth and toluene. Prepn is by cautious vac distn of a mixt of hydrogen polysulfides

Mellor (Ref 3) reports that contact with Cu oxide, Pb mono- or di-oxide, Hg (II) oxide, Sn oxide and tri-iron tetraoxide causes violent decompn and ignition

According to Sax (Ref 5) the toxic threshold level of the trisulfide vap, which is primarily H_2S , is $15mg/m^3$ of air. Exposure to 800–1000ppm of the vap in 30 mins may be fatal. Exposure to a v high concn of the vap (H_2S) results in immediate death. The vap is a v strong irritant to the mucous membranes (Ref 3). The liq trisulfide forms a caustic (Na_2S) when in contact with the skin because of the alkali present in moist skin. This explains the strong irritant action of both the liq and vap (Refs 2, 4 & 5)

Refs: 1) Gmelin, Syst No 9, Teil B (1960)
2) D.T. Hurd, "An Introduction to the Chemistry of the Hydrides", Wiley, NY (1952), 141–42
3) Mellor, Vol 10 (1947), 158–60 4) G. Brauer, Ed, "Handbook of Preparative Inorganic Chemistry", Vol 1, 2nd Edn, Academic Press, NY (1963), 350–56 5) Sax (1968), 826
6) ChemRubHdbk (1978), B-117

Nitrogen Sulfide. See in Vol 8, N102-L & R under "Sulfur Nitride"

2-Propynyl Vinyl Sulfide (or Propargyl vinyl sulfide). $HC\equiv C.CH_2.S.CH:CH_2$; mw 98.17; colorl liq; bp 28° at 10mm; RI 1.5183. Sol in pentane. Prepn is by reacting Na ethyl vinyl sulfide with propynyl bromide in pentane at 0° and then dstlg off the pentane solvent under vac at $20-25^\circ$. The residual is then redistld to remove the sulfide at $28^\circ/10mm$. The yield is 88–93%. Expl decompn occurs above 80°
Refs: 1) Beil, not found 2) L. Brandsma, "Preparative Acetylenic Chemistry", Elsevier, NY (1971), 7 & 181

Sodium Sulfide. See in this Vol under "Sodium and Its Derivatives"

Sulfobenzide, Hexanitro. See in Vol 5, D1480-L & R under "2,4,6,2',4',6'-Hexanitrodiphenyl-sulfone (HNDPhSo), . . ."

Sulfocyanate, Copper. See under "Copper Thiocyanates . . ." in Vol 3, C527-R to C528-L

Sulfocyanate, Lead. See under "Lead Thiocyanate" in Vol 7, L11-L

Sulfonic Acid Compounds

Sulfonic Acid Radical. The formation of a sulfonic acid, ie, a compd contg the $-SO_2.OH$ radical, is accomplished using one, or a mixt of, common sulfonating agents such as sulfuric acid, fuming sulfuric acid, sulfur trioxide, alkali disulfates, pyrosulfates, chlorsulfonic acid, or a mixt of Mn dioxide and sulfurous acid. An example of the type of compds produced (which are considered energetic matls) by applying this procedure may be found in Bestehorn's patent (Ref 1), where it is claimed that sulfonated **1,3-Bis (Nitrophenyl) Triazines** of the general formula

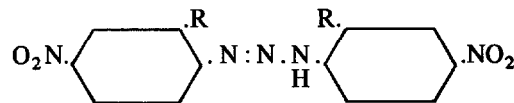

where R is either H or $-SO_3H$ (but at least one R must be $-SO_3H$), have value as pyrot matls. Prepn of the sulfonated bis triazine is by diazotization of 2,4- $R(O_2N)C_6H_3NH_2$ with HCl and Na nitrite and coupling the resultant prod with 2,4- $R(O_2N)C_6H_3NH_2$. See also "Sulfanilic Acid and Derivatives" in this Vol. Other examples of sulfonated compds useful in Ordn are presented below

Refs: 1) H.H. Bestehorn, BritP 642947 (1950) & CA 45, 4267 (1951) 2) CondChemDict (1977), 825

Sulfonic Acid, Azido (or Azino sulfonic acid). $N_3SO_2.OH$; mw 123.10; N 34.14%. Prepn is by HCl neutralization of an alkali metal salt of azido sulfonic acid and then strongly cooling the aq soln

The following compds are considered derivatives of azido sulfonic acid by Shozda and Vernon (Ref 3):

Sulfamoyl Azide. $NH_2.SO_2.N_3$; mw 90.12; N 62.18%; colorl solid; mp $28-29^\circ$. Prepn is by reacting sulfamoyl chloride with Na azide in acetonitrile at RT for 24 hrs. After filtn of the by-product solids, the acetonitrile

solvent is removed under vac and the azide distilled off at 25–50° on a Hickman still. The yield is 60.6%. It is reported that Sulfamoyl Azide has a mech shock sensy comparable to that of NG (Ref 3)

n-Butyl Sulfamoyl Azide. $C_4H_9NH.SO_2.N_3$; mw 178.24; N 31.44%; clear, mobile oil. Prepn is by reaction of sulfuryl azide chloride with n-butylamine in benz at RT for 2.5 days. Yield is 28%. The azide expld when elemental analysis was attempted by combustion (Ref 3)

Sodium Azido Sulfonate. $Na.SO_3.N_3$; mw 145.09; N 28.97%. Prepn is by reacting Na azide with chlorosulfonic acid (by dropwise addn) in methylene chloride at 25–39° for 2 days. The prod is then filtered off in a dry box and washed with methylene chloride. The pptd prod is then added in small portions to an excess of a satd soln of Ba hydroxide at 5–15° and the resulting mixt filtered. After treatment of the filtrate with CO_2 to remove excess Ba hydroxide, it is filtered to remove solids and then rapidly evapd to dryness under vac at 25–40°. The resulting residue is then suspended in anhyd acetonitrile, the suspension mixt filtered, and the filtrate dried to give a yield of 56.96% of a crude prod which assayed at 73% Na Azidosulfonate. The azide salt is reported as a weak expl having a variable sensy to mech shock and heating (Ref 3)

Potassium Azidosulfonate (or Potassium salt of azinosulfonic acid). $K.SO_3.N_3$; mw 161.19; N 26.08%; flat prisms, often 1 cm long. Sol in w. Prepn is by reacting equi-molar amts of hydrazinosulfonic acid and a v cold aq soln of K nitrite. It is reported that the salt explds with brisance on heating (Ref 2)

Sulfuryl Azide Chloride. $N_3SO_2.Cl$; mw 141.54; N 29.74%; colorl liq; bp 116–17°; d 1.44g/cc. Sol in benz, chlf and methylene chloride. Prepn is by reacting Na azide and sulfuryl chloride in dimethyl formamide soln at 25° for 18 hrs with stirring. The prod of this reaction is then vac distld off at 25° and collected in a –45° liq N_2 cooled trap. A 90% yield is reported. Sulfuryl azide chloride has a mech shock sensy sl less than NG. Rapid heating may cause an expln.

The authors (Ref 3) recommend handling the azide as a 25% by wt soln in any of its solvents

Sulfuryl Azide Fluoride. $N_3SO_2.F$; mw 125.09; N 33.60%; liq. Prepn is by reacting Li azide with sulfuryl fluoride in a mixt of dimethylformamide and dimethyl ether at 25° for 19 hrs with stirring. Excess volatiles are then removed at –66° under vac. The reaction flask is then warmed to RT and the azide prod is distld off to a cooled receiver. The authors (Ref 3) report that the azide is believed to be an expl
Refs: 1) Gmelin, Syst Nr 9, Teil B, Lieferung B (1963), 1562 ff 2) W. Trauble & A. Vockerodt, "Über Hydrazine und Azidosulfonsäure", Ber 47, 938 (1914) & CA 8, 2130 (1914) 3) R.J. Shozda & J.A. Vernon, "Derivatives of Azidosulfonic Acid. Halides, Amides and Salts", JOC 32, 2876–80 (1967) & CA 67, 90163 (1967)

Sulfuryl Diazide. See in Vol 1, A621-R and the following *addnl Ref*: Gmelin, Syst Nr 9, Teil B, Lieferung B (1963), 1565

Disulfuryl Azide. $S_2O_5(N_3)_2$; mw 228.18; N 36.84%; yel cryst; mp 17°. Prepn is by reacting azidopolysulfate with an excess of SO_3 at 40° for 2 hrs. The azide explds easily and with great brisance. It must be handled with the *greatest* precautionary measures

Refs: 1) Gmelin, Syst Nr 9, Teil B, Lieferung B (1963), 1566 2) H.A. Lehmann & W. Holz-nagel, ZAnorgChem 293, 314–21 (1957) & CA 52, 9832 (1958)

Benzenediazonium (or Diazobenzene) Sulfonic Acid and Derivatives. See in Vol 2, B57-L & R

3,4-Diamino-5-Nitrobenzene Sulfonic Acid. $(H_2N)_2(O_2N)C_6H_2SO_3H$; mw 233.22; N 18.02%; OB to CO_2 –72.03%; yel solid; mp, expl decompn at 330°. Prepn is by adding 30g of the K salt of 3,5-dinitro-4-aminobenzenesulfonic acid to 500cc of 2N amm hydroxide satd with H_2S , then stirring the mixt for 1 hr at RT, acidifying strongly with concd HCl and cooling. The crude prod is extrd twice with hot w, purified with decolorizing charcoal and cooled to give a yield of 11.2g

Refs: 1) Beil, not found 2) J.R.E. Hoover &

A.R. Day, *JACS* **77**, 5652–55 (1955) & *CA* **50**, 6435 (1956)

Diphenyl Sulfone and Derivatives. See in Vol 5, D1478-R to D1480-R

[(1-p-Sulfophenyl), IV-Acetyl] -Tetrazene (1), (1-[4-Sulfophenyl]-4-acetyl-tetrazene (1), [4-Sulfobenzoldiazo]-[β -acetyl-hydrazide], or Benzolsulfosäure-azo-acethydrizid (Ger)). (p-HO₃S.C₆H₄).N:N.NH.NH(CO.CH₃) has not been prep'd in the free state but its salts and derivs are known

Its **Na Salt**, NaC₈H₉N₄SO₄.2H₂O; mw 316.30; N 17.71%; OB to CO₂ –83.47%; mp (decompn and expln); v. sl sol in w (soln with decompn on standing); prep'n is by treating p-diazo-benzensulfonic acid with acethydrizide (CH₃.CO.N.NH₂) in aq Na carbonate. Puffs off on heating (especially in contact with an open flame). The dry salt is v stable in storage
Refs: 1) Beil **16**, (419) 2) O. Dimroth & G. de Montmollin, *Ber* **43**, 2912 (1910) & *CA* **5**, 493 (1911)

Sulfonium Radical Compounds or Sulfines.

The radical is defined (Ref 5) as R₃S–, where R is an organic radical. Inclusion of this radical in a sulfine comp'd results in the formula R₃SX, where X is an electronegative element such as Cl or a radical such as –ClO₄. An example of an Ordn useful sulfine is the perchlorate shown below

Trimethylsulfonium Perchlorate, Me₃S⁺.ClO₄[–]; C₃H₉ClO₄S; mw 176.63; OB to CO₂ –63.4%; rhombic crysts; mp above 267° (Ref 2), expln temp 280° (Ref 3). It was prep'd by passing a soln of the iodide thru a column of Nalcite SBR ion exchange resin contg exchangeable perchlorate ions, and the eluate evap'd until crysts appeared (Ref 4)

Refs: 1) Beil **1**, (144) & (1280) 2) K.A. Hofmann et al, *Ann* **386**, 315 (1912) 3) R.L. Datta & N.R. Chatterjee, *JCS* **115**, 1009 (1919) 4) C.G. Swain & L.E. Kaiser, *JACS* **80**, 4091 (1958) 5) Hackh's (1972), 646–47

Sulfoxide Radical. Denoted by the formula –SO–. Sulfoxides are organic comp'ds of the general formula R.SO.R which are obt'd by oxidation of mercaptans (analogous to ketones). They form both metal perchlorate complexes and nitrated organic derivatives. Examples of these comp'ds of Ordn interest are presented below

Ref: Hackh's (1972), 647

Dimethylsulfoxide and Perchlorate Derivatives.

Dimethylsulfoxide (DMSO). See Vol 5, D1373-R

Dimethylsulfoxide Complexes of Metal Perchlorates

Hexakis (dimethylsulfoxide) chromium (III) Triperchlorate. (Me₂SO)₆Cr⁺⁺⁺.3ClO₄[–]; C₁₂H₃₆Cl₃CrO₁₈S₆; mw 819.12; OB to CO₂, CrO & SO –56.7%; green monoclinic crysts; expl'd at 247° (Ref 9); CA Registry No [14873-02-0]. It was prep'd by treatment of Cr triperchlorate with an excess of DMSO and recrystn of the resulting solid from DMSO in a vacuum (Ref 9)

Octakis (dimethylsulfoxide) cobalt (II) Diperchlorate. (Me₂SO)₈Co⁺⁺.2ClO₄[–]; C₁₆H₄₈Cl₂CoO₁₆S₈; mw 882.71; OB to CO₂, CoO & SO –80.7%; a solid, expl'ds from 200–35° (Ref 10)

Tetrakis (dimethylsulfoxide) copper (II) Dipperchlorate. (Me₂SO)₄Cu⁺⁺.2ClO₄[–]; C₈H₂₄Cl₂CuO₁₂S₄; mw 574.87; OB to CO₂, CuO & SO –51.5%; green crysts, expl'ds at 200° (Ref 7); CA Registry No [15225-62-4]. It was prep'd by the dropwise addn of DMSO to an aq soln of Cu perchlorate and the ppt recryst'd from acet (Ref 7)

Nonakis (dimethylsulfoxide) copper (II) Dipperchlorate. (Me₂SO)₉Cu⁺⁺.2ClO₄[–]; C₁₈H₅₄Cl₂CuO₁₇S₉; mw 965.42; OB to CO₂, CuO & SO –84.5% a bright green solid (Refs 3 & 4); expl'ds from 200–35° (Ref 10). It was prep'd by adding a hot soln of Cu dipperchlorate to DMSO, followed by cooling the mixt until crysts formed (Ref 4)

Hexakis (dimethylsulfoxide) gallium (III) Triperchlorate. (Me₂SO)₆Ga⁺⁺⁺.3ClO₄[–]; C₁₂H₃₆Cl₃GaO₁₈S₆; mw 836.80; OB to CO₂, Ga₂O₃ & SO –53.1%; a white solid, expl'ds on heating (Ref 5); CA Registry No [29519-19-5]

Hexakis (dimethylsulfoxide) iron (II) Diperchlorate. $(\text{Me}_2\text{SO})_6\text{Fe}^{++}\cdot 2\text{ClO}_4^-$; $\text{C}_{12}\text{H}_{36}\text{Cl}_2\text{FeO}_{14}\text{S}_6$; mw 723.53; OB to CO_2 , FeO & SO -69.7%; a yellow solid, explds on heating (Ref 5); CA Registry No [16742-95-3]

Hexakis (dimethylsulfoxide) iron (III) Triperchlorate. $(\text{Me}_2\text{SO})_6\text{Fe}^{+++}\cdot 3\text{ClO}_4^-$; $\text{C}_{12}\text{H}_{36}\text{Cl}_3\text{FeO}_{18}\text{S}_6$; mw 822.98; OB to CO_2 , FeO & SO -53.5%; a pale yellow solid, explds ca 200° (Ref 8); CA Registry No [14245-13-7]. It was prepd by adding dropwise a soln of Fe triperchlorate nonahydrate in acet to DMSO until crystn was complete (Ref 8)

Hexakis (dimethylsulfoxide) manganese (II) Diperchlorate. $(\text{Me}_2\text{SO})_6\text{Mn}^{++}\cdot 2\text{ClO}_4^-$; $\text{C}_{12}\text{Cl}_2\text{H}_{36}\text{MnO}_{14}\text{S}_6$; mw 722.54; OB to CO_2 , MnO & SO -69.8%; a cryst solid, explds from $200-35^\circ$ (Ref 10); CA Registry No [16884-55-2]

Hexakis (dimethylsulfoxide) nickel (II) Diperchlorate. $(\text{Me}_2\text{SO})_6\text{Ni}^{++}\cdot 2\text{ClO}_4^-$; $\text{C}_{12}\text{H}_{36}\text{Cl}_2\text{NiO}_{14}\text{S}_6$; mw 726.30; OB to CO_2 , NiO & SO -69.4%; a bright green solid (Ref 2), explds from $200-35^\circ$ (Ref 10); CA Registry No [16742-94-2]. It is prepd by dehydration of Ni perchlorate hexahydrate with an excess of 2,2-dimethoxypropane, an excess of DMSO added, then an equal vol of eth which ppts the solid complex (Ref 6)

Octakis (dimethylsulfoxide) nickel (II) Diperchlorate. $(\text{Me}_2\text{SO})_8\text{Ni}^{++}\cdot 2\text{ClO}_4^-$; $\text{C}_{16}\text{H}_{48}\text{Cl}_2\text{NiO}_{16}\text{S}_8$; mw 878.87; OB to CO_2 , NiO & SO -81.0%; a cryst solid, explds from $200-35^\circ$ (Ref 10)

Refs: 1) Beil, none of the above complexes found 2) Gmelin, System No 57, Part C-2 (1969), 936 3) Gmelin, System No 60, Part B-4 (1966), 1534 4) H.L. Schläfer & W. Schaffernicht, *AngewChem* **72**, 618 (1960) & *CA* **55**, 14036 (1961) 5) J. Selbin et al, *JInorgNuclChem* **16**, 219 (1961) & *CA* **55**, 14155 (1961) 6) D.W. Meek et al, *InorgChem* **1**, 285 (1962) 7) M. Suwalsky W. & T. Jara P., *BolSocChileanQuim* **13**, 23 (1963) & *CA* **66**, 71990 (1967) 8) T. Jara P. et al, *RevRealAcadCiencExactas,FisNautrMadrid* **60**, 623 (1966) & *CA* **67**, 87318 (1967) 9) D. Moneva M. et al, *RefRealAcadCiencExactas, FisNautrMadrid* **60**, 649 (1966) & *CA* **67**, 87319 (1967) 10) M. Glavas & T. Skerlak, *GlasHejTehnolBosneHercegovine* **15**, 41 (1967) & *CA* **69**, 64250 (1968)

Trimethylsulfoxonium Perchlorate. $\text{C}_3\text{H}_9\text{ClO}_5\text{S}$; mw 192.63; OB to CO_2 and SO -49.8%. Two

isomers of trimethylsulfoxonium perchlorate have been reported

O,S,S-Trimethylsulfoxonium Perchlorate. $\text{Me}_2\text{S}^+\text{OMe}\cdot\text{ClO}_4^-$. An impact and heat sens solid, explds on heating. It was prepd by the addn of dimethylsulfoxide to Ag perchlorate in ete chloride followed by an excess of me iodide. The pptd salts were filtered off and the perchlorate extd out with acetonitrile. C tetrachloride was added to the ext to ppt the perchlorate salt. *Caution!* A sample of the dry salt detond spontaneously while being stored in a vacuum desiccator

S,S,S-Trimethylsulfoxonium Perchlorate. $\text{Me}_3\text{SO}^+\text{ClO}_4^-$; a cryst solid, mp $271-75^\circ$ with decompn. *Caution!* On one occasion a sample detond violently at 262° . It was prepd by the interaction of the iodide salt with Ag perchlorate in aq soln *Refs:* 1) Beil, not found 2) N.J. Leonard & C.R. Kohnson, *JACS* **84**, 3709 (1962)

Diphenylamine Sulfoxide and Derivatives. See in Vol 5, D1441-L & R

Sulfur (Brimstone, Flowers of sulfur, Sulfur flour, S, or Sulphur). S, forms the cycloocta molecule S_8 (a stable crown shape); at wt 32.046 ± 0.003 ; at no 16; valences 2, 4, 6; four naturally occurring isotopes: 32 (95.0%), 33 (0.76%), 34 (4.22%) and 36 (0.014%); artificial (radioactive) isotopes: 29-31, 35, 37 & 38; mw 256.512 for the α , β , and γ forms of S_8 . Table 1 presents the properties of the α , β & γ forms of molecular sulfur and μ , the amorph form. CA Registry No [7704-34-9]. Sulfur occurs both in the free state and in combination, usually as sulfides (iron pyrites, etc) and sulfates (gypsum, etc). It constitutes about 0.05% of the crust of the earth. Commml prepn of sulfur is by either the Frasch process of direct mining (30), Chemico process of refining pyrites (20) and low grade ores (20) or the Thylox process involving coke oven gas (30%). Commml S is purified by repeated recrystn from C disulfide (Ref 16)

Sulfur is sponty flammable with an open cup flash pt of 405°F , a closed cup flash pt of 440°F and an autoign temp of 450°F . According to Ref 17 (p 298), the Q_c of the α form is 2.200, and of the β and γ forms, 2.240kcal/g. Also,

Table 1
Properties of Molecular Sulfur

Form	Physical Characteristics	mp, °	bp, °	d, g/cc	RI	Solubility
α ; 16 eight- membered rings	Cycloocta, orthorhombic, amber yel cryst	95.5 (transition to β); 112.8 (range)	444.674	2.07 at 20°	1.957	Sol in CS ₂ ; sl sol in ethanol, benz, eth, CCl ₄ and liq ammonia; not sol in w
β ; 6 eight- membered rings	Cycloocta, monoclinic, light yel opaque, brittle ndl-like cryst	118.75	444.674	1.96	2.038	Sol in 70° CS ₂ , ethanol, and benz; not sol in w
γ	monoclinic, v light yel or "mother-of-pearl" sulfur	106.8 ca 120 (separate values)	444.674	1.92	1.957	Not sol in CS ₂ or w
μ	Amorph, pale yel, mw ~200,000 (Ref 38), called "Cystex"	gradually reverts to α form	444.674	—	1.957	Not sol in orthorhombic form solvents

according to Ref 17, the min expl concn of S dust in air is 30–35mg/l

The explosibility or inflammability parameters of S (dust) have been investigated by a number of workers. Bayersdorfer and Braun (Ref 2) report a numerical inflammability index of S dust as 39. The index is defined (by the authors) as the ratio of Q_c to Q_{ign} . Stonavsky (Ref 14) examined the causes of S dust fires and found the major causes to be self-ign, static electricity, metallic sparking, bare electricity-carrying wires or open flames. Additional exptl data supplied by Kuznetsov et al (Ref 30) indicates that still another cause for spontaneous S explns is the heat evolved during a chemical reaction such as that between AN and Fe sulfide. The authors simulated the conditions which caused spontaneous explns of expl charges contg AN which occurred in blast holes in an open pit mine of the Gask (Russ) deposit of sulfide ores to reach this conclusion. The patent of Pedemont and McPaul (Ref 31) claims to have eliminated the expl properties of aerielly spread gypsum-S mixts by forming an intimate mixt of the two components. The process involves granulation using 5–10% bentonite clay as the

binder. Zemskii and Zhukov (Ref 40) are reported to have defined the expl limits of Fe, S, and Zn stearate powders and their mixts in air. More recently, Hulisz (Ref 44) investigated the explosiveness and inflammability of high-S petr coke and found that coke dust of a grain size <75 μ m is nonexpl, but a fire hazard exists at >400° as a 5mm thick layer of the dust becomes incandescent at 420–70° and ign occurs at 520–666°. Birzul and Olishkevets (Ref 45) examined the characteristics of the flammability and explosiveness of sulfur ore dust and concluded that the fire and expl hazards of ground S ores are decreased by removing both fine and coarse particle content and decreasing the total amt of deposited dust, as well as limiting exposure to ign sources

The use of S as a fuel in expls dates from the first expl, BlkPdr. For information on the use of S in BlkPdr see Vol 2, B165-R to B179-R and the listed supplemental refs at the end of this article. See also the material on Pyrodex in Vol 8, P500-L and P517-R, and S/K chlorate expls in Vol 2, C190-R

Urbański and Pillich (Ref 4) report on the effects of adding S to expls. They found that S

appreciably decreases the temp of deton of TNB (from 400+ to 291°/40% S), α -TNT (from 333 to 275°/40% S), γ -TNT (from 321 to 268°/30% S), PA (from 330 to 247°/30% S), Trinitro-cresol (from 299 to 255°/30% S), and Tetryl (from 203 to 192°/30% S). However, addn of S to RDX and NGu actually raised the deton temp; for RDX from 229 to 245°/30% S and for NGu from 243 to 246°/30% S. It is also reported that the addn of S increases the impact sensy of Tetryl by approx 33%. This effect, considered by the authors to be partially mechanical due to the introduction of hard crystn S into the expl, reaches a max at about the 10% S addn level. Richardson's patent (Ref 12) claims that expls suitable for quarrying, open-pit, and strip mining operations are obtd by combining S, a liq nitro aromatic compd, AN and Al. For example, a compn consisting of S (79), DNT (3), AN (15) and Al (3%) is prepd by tumbling S (10-40 mesh) in a drum while liq DNT is added. This initial prepn step is followed by addn of finely powdered AN (100 mesh) and Al, and again tumbling. The inventor reports that the resulting expl propagates continuously in a 7/8" diam column at a rate of 5500fps (1676m/sec) when initiated by a No 6 blasting cap and exhibits a BuMines Pb block test value of 8mm (Ref - USBuMines Bull 346, p 107). It is claimed in Reinhardt's invention (Ref 13) that the dispersed and random addn of hollow, wax or clay coated pellets of S to normal gelatine Dynamite maintains the sensy of the Dynamite to deton under conditions of high w press by providing oxygen to propagate the deton and dry fuel in the form of S to sustain it, while the SO₂ formed during deton generates enough press to prevent the w from causing a misfire. The inventor reports the Dynamite compn to also include varying amts of NC, NG, DNT, urea, DPA, Ca carbonate, AN and carbonaceous solid fuels such as woodpulp, corn, flour, bagasse, etc. An interesting sidelight on the use of S in connection with expls is reported by Hauver and Netherwood (Ref 15) who used S as a piezoid element to measure the hydrodynamic press-time profile for detong Baratol which was placed in direct contact with the S element. The authors conclude that their data confirms the vonNeumann (hydrodynamic) theory of deton. The patent of Jardine and Travers (Ref 28) suggests that a

w-insol fuel such as S be added to an AN based expl to increase the expl's deton sensy for quarrying purposes. Gangaly (Ref 34) has detd from manual impact sensy tests that a dry powdered mixt of $\geq 20\%$ S with K chlorate forms an expl mixt. According to the NFPA (Ref 35) S forms impact sensitive compns with Al, AN, Amm perchlorate, bromates, charcoal, chlorates, chlorates and Cu, Pb chlorite, Pb dioxide, Hg (ous) oxide, inorganic perchlorates, PO₃, K perchlorate, Ag nitrate, Na nitrate and charcoal. This ref also reports that when the following elements or compds are individually mixed with S and heated, an expln occurs: bromates, chlorates, iodates, Ca hypochlorite, chromic anhydride, mercuric oxide, K permanganate, Sr carbide, and Zn. The patent of Wasson (Ref 39) claims that stable AN expl slurries can be prepd using $\geq 3\%$ S. As an example the following compn was prepd and deton: AN (46.5), fertilizer grade Ca nitrate (30), Na nitrate (13.4), S (3), Al (suitable for grinding, 6), and other components (1.07 wt %). The inventor reports that this compn has a d of 1.06g/cc, a critical diam of 10cm and a deton vel of 3500m/sec

The proplnt-igniter compn called "Benite" invented by Hassmann (Ref 18) is of interest at this point. The inventor claims to have produced a compn superior to BlkPdr, consisting of NC (39-41), K nitrate (43.3-45.3), S (6.0-6.6), charcoal (9.1-9.7), and Nitro DPA as the stabilizer (0.4-0.6 wt %), which has a reported Q_c of 910cal/g, a hygroscopicity of 1.9%, and provides rapid and uniform ign of 90mm HE round proplnt to aburning rate of 3810 \pm 53fps at -65°F. See also in Vol 2, B173-R to B174-L

The use of S as both a fuel and as a cross-linking agent in polysulfide rubbers provides a strong matrix for solid proplnts, and the highly desirable properties of oil insolubility and vapor impermeability (Ref 36). Information on polysulfide rubbers is presented in Vol 3, C465-L and C467-L under "Thiokol"; also in Vol 8, P350-L to P351-R under "Polysulfide Polymers". There are other proplnt compns contg S as shown next. The patent of Greiner (Ref 25) claims an under-w proplsn system using as fuel a slurry of Mg in S and as oxidizer molten Li chlorate-perchlorate (at 120-35°). In the work of Pallay and Zovko (Ref 27), various mixts of

CITW NOT
ENTER
TEXT

Table 2
Composition and Parameters of an Optimum Gas Generating Composition for
Gas Dynamic Laser Studies

Composition, (Wt %)	Grain d, g/cc; Grain Diam, inches	Reaction Prod, Gaseous; Liquid	Combustion Chamber Press, psia	Adiabatic Flame Temp, °K	Burn Time, Sec	Burning Rate, in/sec
NaN ₃ (66.9)	1.7;	N ₂ , CO ₂	824 to	1996	-	-
S (17.08)	2.21	NaOH, CO,	1000	(theoretical)	0.57	1.76
C (2.04)		Na, SO ₂ , H ₂				
NaNO ₃ (10.95)		and SO				
NaHCO ₃ (2.94)		Na ₂ S and Na ₂ SiO ₃				

Na azide and S were pressed into grains as propellant-like compounds to serve as generators for supplying gas mixtures for gas dynamic laser applications. The optimum compound and its performance parameters as reported by the authors are shown in Table 2. As a further result of their work in gas dynamic lasers, Boyars and Zovko (Ref 32) have patented a series of S containing pure N₂ or pure N₂-CO₂ mixture gas generating propellants. A pure N₂ gas generating compound, for example, consists of 20g of NaN₃ (80) and S (20 wt %), which is ignited with 2g of B/K nitrate. Similarly, for an N₂-CO₂ gas mixture the suggested compound consists of NaN₃ (60), S (15), and Na₂CO₃ (25 wt %).

Sulfur has found extensive and long-time usage in pyrotechnic compounds as a fuel because it is abundantly available, cheap, safe to handle, nontoxic (? see below), and of good stability, easily ignitable, provides a continuity of combustion, and consolidates pyrotechnic mixtures as burning progresses (Refs 3 & 21). For information on the use of S in pyrotechnics, see in Vol 8, P517-L & R under refs for "BlkPdr" and "Pyrodex", and in Vol 6, F63-L to F69 (fig) under "Flare . . .", F70-L to F72-R under "Flare, German", and the following reported work. When combined, Ba chromate (74-77), Mn (20-22) and S (3-4%) has been used to form gasless powders for (pyrotechnic) delay elements of fuzes (Refs 5, 6, 9, 10 and 16). Baldwin and Wooldridge (Ref 20) report on pyrotechnic dissemination research which has resulted in some pressure rise and differential thermal analysis data

on S-K chlorate and methyl aminoanthraquinone-S mixtures. However, the primary reason reported for the program is the objective of developing burning rate catalysts or fuel mixtures which would decrease the dangerous shock sensitivity of S-K chlorate mixtures and still provide the quick dissemination of smoke or other agents. The authors conclude that chemical additives are *not* successful in meeting the objective, therefore, they recommend physical design modification of the pyrotechnic - not formulation modification. According to Ellern (Ref 21, pp 355 to 371) S has been used for centuries in amounts ranging from 2-17% in fireworks such as various flash reports, lights, lances, Roman candle fuses, rockets and stars; incendiaries such as "thermite"; railroad flares; gerbs; matches; colored smokes; starter mixtures; railroad torpedoes; and arty tracers. All of these compounds include an oxidizer such as a chlorate, perchlorate, and/or nitrate in amounts of from about 10 to 30%, binders, associated fuels and special purpose agents such as dyes for smokes, etc. In the area of incendiaries Tomlinson (Refs 7 & 8) reports on the incendiary component of Russ 76mm AP HE shells. Examination revealed a compound of Al (46.1), Ba nitrate (38.9), TNT (14.7) and S (0.3%) which has an impact sensitivity of 23cm (using a 2kg wt), explosion temperature of 465°, a sensitivity to initiation of 0.25g MF, and a density of 2.09g/cc. Kriete (Ref 11) reports on a modified M69 incendiary bomb filled with 4.7lbs of S-Al in 50/50 mixture (called "Sal-X"). The bomb, when tested against simulated Jap bunkers, produced

large quantities of smoke and toxic SO₂ gas. The author concluded that this device makes an excellent weapon against such a target. Amcel Corp (Ref 19), in reporting on an investigation of the hazards (safety) inherent in pyrot processing, recommends a reclassification of smoke mixts contg S, K chlorate and Na bicarbonate [with (found to be the least impact sensitive) and without (the most impact sensitive) dyes] as "Class 9" expls. For example, it was found that grn and yel smokes are slightly less sensitive to impact than TNT. The report (p 6) further recommends that "... modification of facilities to conform with Class 9 requirements could be averted by preblending the dyes with the fuel and sodium bicarbonate and adding the potassium chlorate as the last ingredient, thus avoiding formation of the most hazardous mixture ...". Note: The current AMCR Safety Manual: Anon, "Safety-Safety Manual", **AMCR 385-100** (April 1970) with DARCOM Change 3 (11 January 1977), lists no "Class 9" designation. Hence, the Amcel report should serve as a guide to the more cautious manufg, handling and storage of pyrots

McKowan et al (Ref 43) report that K chlorate/S mixts and M-18/S red smoke mixts were subjected to additive sensy testing primarily by differential thermal analysis, and by measuring the blast press equiv of 100g samples. The additives investigated by the authors included Fe, Cu, Mn, Cr, Ni, Co, oxides, Cu salts, and chlorates at concns of 1, 5, 10, 17.5 and 25% for each additive. All the metals and oxides examined caused no significant increase in the sensy of the K chlorate/S mixt with the exception of Co. However, the addn of Cu salts and especially the chlorates resulted in a greatly increased sensy. The authors conclude that Cu and Cu alloy tools and screens may remain in pyrot manufg plants since neither Cu nor its oxidation products [CuO or Cu₂(OH)₂CO₃] cause a significant increase in sensy of the pyrot mixts, nor do the authors consider it possible that those contaminants causing increased sensy [such as Cu(NO₃)₂, CuSO₄ or Cu(ClO₃)₂] will be formed in the manufg processes

According to Sax (Ref 22), S is considered to have a very low toxicity, however, according to Sörbo (Ref 29), S aerosols cause eye irritation in human beings, the threshold being as low as

0.2ppm. Colloidal S administered by intravenous injection is fairly poisonous, the lethal dose reported to be 5-10mgs/kg of body wt. Sörbo attributes the toxicity in the latter instance to conversion of S to H₂S by reaction with glutathione and with protein-bound sulfhydryl groups

The current US Military Specification for sulfur (Ref 23) lists the following chemical requirements as shown in Table 3:

Table 3
Chemical Requirements for Sulfur

	Min %	Max %
Sulfur (dry basic) ^{-a}	99.5	—
Moisture ^{-b}	—	0.5
Ash ^{-c}	—	0.1
Organic Impurities ^{-d}	—	0.1

Footnotes to Table 3

a—by calculation

b—gravimetrically by drying a 50g sample for 12 hrs at 82°, cooling in a desiccator and then weighing

c—gravimetrically by igniting a 15g sample to burn off the S, cooling and weighing for wt "A", and then burning off the organic impurities thus leaving the ash "B"

d—by using the following calculation:

$$\% \text{ organic impurities} = \frac{(A-B) \times 100}{\text{sample wt}}$$

Refs: 1) Gmelin, Syst Nr 9, Teil A (1953), 511-21 1a) Daniel (1902), 724-28 2) P. Beyersdorfer & L. Braun, "Inflammability", ZTechPhysik 9, 17-19 (1928) & CA 22, 2058 (1928) 3) G.J. Schladt, "Modification of M-8 Flare Composition to Increase Candlepower", PATR 538 (1934) 4) T. Urbański & M.J. Pillich, "Action Du Soufre Sur Les Explosifs", MAF 18, 1013-20 (1939) & CA 34, 4905 (1940) 5) D. Hart, "Gasless Powders for Delay Elements of Fuzes", PATR 1239 (1943) 6) Ibid, PATR 1281 (1943) 7) W.R. Tomlinson, "Compilation of Data on the Composition of Foreign Boosters and High Explosives", PATR 1311 (1943) 8) Ibid, "Properties of Ternary Mixtures of High Explosives", PATR 1360 (1943) 9) D. Hart, "Gasless Powders for Delay Elements of Fuzes", PATR 1406 (1944) 10) S. Sage, "Manufacture of Barium Chromate Delay Powder on a Semi-Plant Scale",

- PATR 1432 (1944) 11) B.C. Kriete, "Test of Modified M69 Incendiary Bombs Filled With Sulphur and Aluminum Powder (Sal-X)", TDMR 915 (1944) 12) W.B. Richardson, "Sulfur Explosives", USP 2647047 (1953) & CA 47, 10852 (1953) 13) W. Reinhardt, "Gelatin Dynamite Composition Containing Pelletized Sulfur", USP 2674526 (1954) & CA 48, 7904 (1954) 14) J. Stonavsky, "The Causes of Sulfur Fires and Explosions and Their Elimination", ChemPrumysl 8, 86-87 (1958) & CA 52, 12401 (1958) 15) G.E. Hauver & P.H. Netherwood, "Pressure Profiles of Detonating Baratol Measured with Sulphur Gauges", BRL 1452 (1962) 16) G. Brauer, Ed, "Handbook of Preparative Inorganic Chemistry", Vol 1, 2nd Edn, Academic Press, NY (1963), 341-43 17) Anon, Engrg Design Hdbk, Mil Pyrot Series, "Part Three-Properties of Materials Used in Pyrotechnic Compositions", AMCP 706-187 (1963), 294-98 18) H.F. Hassmann, "Igniter Assembly Containing Strands of Benite", USP 3182595 (1965) & CA, not found 19) Anon, "Investigation of Hazards in the Processing of Pyrotechnic Mixtures for Chemical Agent Munitions", ATR-50, Amcel, Asheville, Contract No DA-18-035-AMC-296(A) (1965) 20) J.E. Baldwin & C.E. Wooldridge, "Pyrotechnic Dissemination Research Studies", SRI, Menlo Park, Contract DA-18-035-AMC-122(A) (1967) 21) Ellern, "Pyrotechnics" (1968), 47, 76, 132 f, 135, 155 f, 173, 193, 227, 235, 239, 322 ff 22) Sax (1968), 1127 23) Anon, "Sulfur: Commercial Grade (For Use in Ammunition)", MIL-S-14929 (MU) (1968) 24) J.R. Gibson & J.D. Weber, "Handbook of Selected Properties of Air- and Water-Reactive Materials", NAVAMMODEP RDTR 144 (1969), 21-22 25) L. Greiner, "Solid Fuel and Oxidizers for Underwater Propulsion System", USP 3527050 (1966) & CA 73, 111494 (1970) 26) Sax (1968), 1127 26a) J.R. Gibson & J.D. Weber, "Handbook of Selected Properties of Air- and Water-Reacting Materials", RDTR 144 (1969) 27) B.G. Pallay & C.T. Zovko, "Chemical Generation of High Temperature, High Pressure Gas for Laser Application", NOLTR-71-131 (1971) 28) N.M. Jardine & R. Travers, "Ammonium Nitrate Explosive Compositions", SAfrP 6807253 (1968) & CA 74, 143987 (1971) 29) A. Senning, Ed, "Sulfur in Inorganic Chemistry", Vol 2, Dekker, NY (1972), 145 ("The Pharmacology and Toxicology of Inorganic Sulfur Compounds" by B. Sörbo) 30) G.V. Kuznetsov et al, "Reasons for the Spontaneous Explosions of Charges of Ammonium Nitrate Explosives in Sulfide Ores", GornZh(Russ) 147, 71-74 (1971) & CA 76, 115661 (1972) 31) M.E. Pedemont & K.S. McPaul, "Sulfur Fortified Gypsum", AustralianP 413208 (1971) & CA 76, 71467 (1972) 32) C. Boyars & C.T. Zovko, "Nitrogen Generator", USP 3775199 (1972) & CA 80, 97999 (1974) 33) Omitted 34) A. Ganguly, "Effect of Impact on Some Common Explosive Mixtures of Potassium Chlorate", JIndianAcadForensicSci 12 (1), 29-30 (1973) & CA 80, 110507 (1974) 35) Anon, "Fire Protection Guide on Hazardous Materials-6th Edition", NFPA, Boston (1975), 491M-400 to 405 36) J.R. West, Ed, "New Uses of Sulfur", ACS 140, ACS, Washington (1975), 2 37) Omitted 38) Merck (1976), 1162 (No 8764) 39) D.A. Wesson, "Calcium Nitrate and Sulfur-Containing Explosives", USP 2601162 (1975) & CA 85, 1629435 (1976) 40) G.T. Zemskii & V.V. Zhukov, "On the Explosive Concentration Limit of Iron, Sulfur and Zinc Stearate Powders and Their Mixtures", PreduprezhdenieVnezapnVozplameneniiPoroshkov i VzryvovGazodispersnSistem, 139-41 (1975) & CA 85, 8720 (1976) 41) Omitted 42) CondChemDict (1977), 826 43) G.L. McKown et al, "Effects of Copper and Heavy Metals on the Sensitivity of Pyrotechnic Materials", Compat Plast Other Matl Expls, Proplnts, Pyrot Symp 1976, I-B & CA 87, 103955 (1977) 44) S. Hulisz, "Investigations on the Explosiveness and Inflammability of High-Sulfur Petroleum Coke", Nafta (Katowice, Pol) 1976, 32 (3), 90-94 & CA 86, 19269 (1977) 45) A.M. Birzul & V.A. Olishkevets, "Characteristics of the Flammability and Explosiveness of Sulfur Ore Dust", PreduprezhdenieVnezaphykh-VosplameneniiPoroshkiVzryvovGazodispersnykhSis, 137-39 (1975) & CA 86, 1578075 (1977) 46) S. Oae, Ed, "Organic Chemistry of Sulfur", Plenum, NY (1977), 1-71
Supplemental Refs on BlkPdr: A) Anon, "A Study of Modernized Techniques for the Manufacture of Black Powder", Chromalloy Corp, Edwardsville, Contract DAI-23-072-501-ORD-

(P)-43 (1960) B) Anon, "Military Explosives", **TM 9-1300-214** to **11A-1-34** (Nov 1967), 6-1 to 6-6 C) A.A. Borisov et al, "Ignition of Powdered Fuels Behind Shock Waves", **FTD-HT-23-720-68** (1968) D) R.A. Whiting, "The Chemical and Ballistic Properties of Black Powder", **HNYWLL-GAP-71-01**, Honeywell, Hopkins (1970) D1) R.A. Whiting, "The Chemical and Ballistic Properties of Black Powder", **PB 198341, HNYWLL-GAP-71-01**, Honeywell, Hopkins (1970, reprint 1971) E) H.S. Napadensky & J.J. Swatosh, "TNT Equivalency of Black Powder. Vol I. Management Summary and Technical Discussion", **IITRI-J6265-3**, Vol 1 (1972) F) Ibid, Vol 2 G) K. Lovold, "Preparation of Black Powder", USP 3660546 (1972) & **CA 77**, 64227 (1972) G1) B.D. Trott, "Effect of Cryogenic Temperatures on the Performance of Selected Explosives", **NAVE OD FAC-TR-144**, Battelle Columbus Labs, Columbus, Contract N00174-72-C-0214 (1972), Limited Distribution H) W. Hintze, "Black Powder Rocket Propellants", GerP 2127800 (1972) & **CA 78**, 113567 (1973) I) Ibid, GerP 2328010 (1974) & **CA 82**, 127170 (1975) J) W.L. Rollwitz et al, "Determining the Potential of Radiofrequency Resonance Absorption Detection of Explosives Hidden in Airline Baggage", **SWRI-15-4225-F** (1975)

(Di) **sulfur Dinitride**. S_2N_2 ; mw 184.3; N 15.20%; large colorl cryst, iodine-like odor; mp, sublimes at RT at 10^{-2} mm. Sol in acet, alcs, benz, eth, CCl_4 , dioxane, and tetrahydrofuran. Prepn is by *cautious* thermal degradation of S_4N_4 at 80–300° and 0.005mm. Yield is 80%. Disulfur dinitride polymerizes readily at RT in the presence of traces of moisture to $(SN)_x$ (67%) and dimerizes to S_4N_4 (33%). It deton violently at 30° or above by shock, friction, strong mech press and temp. When dissolved in 2N NaOH it forms large blk crystals in a yel soln. These crystals deton readily

Refs: 1) Gmelin, Syst Nr 9, Teil B (1960), 1536 ff 2) G. Brauer, Ed, "Handbook of Preparative Inorganic Chemistry", Vol 1, 2nd Edn, Academic Press, NY (1963), 409–10

Sulfur Hexafluoride. See in Vol 6, F148-L and the following *Addnl Refs*: 1) C. Boyars & C.T. Zovko, "Nitrogen Gas Generating System", USP 3773947 (Nov 1973) & CA, not found [The inventor claims a method of generating hot N_2 gas by contacting SF_6 with Na azide in the presence of a conventional propl initiator] 2) R.N. Dietz et al, "Tagging Explosives with Sulfur Hexafluoride", USP Application 577822 (1975) & **CA 87**, 8192 (1977) [The inventors claim a method of tagging expls with SF_6 by absorbing it in fluorocarbon polymers which are incorporated in the detonator or blasting cap. Detection is accomplished with sensitive sniffing devices]

Sulfuric Acid (Oil of vitriol, Oil (spirit) of vitriol, Hydrogen sulfate or Battery acid). H_2SO_4 ; mw 98.08; colorl to drk brn oily liq, also in the form of *fuming sulfuric acid* or oleum which is $XH_2SO_4 \cdot YSO_3$; fp 10.365°, 10.37° (sep values); bp 279.6° (Ref 9); d 1.8269g/cc at 25/4°. Exhibits extreme hygroscopicity in that sulfuric acid is miscible with w in *all* proportions. It is an excellent solvent for SO_3 . CA Registry No [7664-93-9]. Prepn is from sulfur, pyrite, hydrogen sulfide or sulfur contg smelter gases by the "Contact" process (V pentoxide catalyst); $2SO_2 + O_2 = 2SO_3$, and $SO_3 + H_2O = H_2SO_4$ (Refs 9, 14 & 17). Prepn can also be obt'd from SO_2 by the "Cat-Ox" process using V pentoxide as a catalyst; $2SO_2 + O_2 = 2SO_3$, and $SO_3 + H_2O = H_2SO_4$ (Ref 17, p 172-R). The acid can be obt'd in the following grades: Commercial; 60°Bé (sp gr 1.7, 77.7% H_2SO_4); 66°Bé (sp gr 1.84, 93.2% H_2SO_4); 98% (sp gr 1.84); 99% (sp gr 1.84); 100% (sp gr 1.84) (Ref 17)

According to both the NFPA Guide and Bretherick (Refs 5 & 13), sulfuric acid causes *explosions* and/or *fires* when in intimate contact with a large number (over 70) of materials including acetic anhydride, acet and nitric acid, acrolein, alcohols, alcohols and hydrogen peroxide, amm hydroxide, aniline, bromine and metals, carbides, chlorates, cyclopentadiene, ethylene glycol, various hydrocarbons, hydrochloric acid, iron, mercuric nitride, powdered metals, perchlorates, picrates, pyridine, Na carbonate, steel, sucrose, vinyl acetate, and w. Illustrative

of the expl power of sulfuric acid are the following reports of accidents involving this matl. Cohen (Ref 3) reports an expln in the sulfuric acid feed lines from a storage tank caused by a white pasty mass clogging the lines. The mass deton when a pipe fitting was broken by an iron maul. Later analysis of the pasty matl showed over 10% Fe in the forms of basic ferrous sulfate, anhyd ferrous sulfate and sulfite, and also some H_2SO_3 and a large amt of H_2SO_4 . Schrieber (Ref 4) reports a similar expln which also occurred in an acid pipeline from a storage tank when a valve was opened. Schrieber concludes that H_2 which had accumulated from the reaction of sulfuric acid and Fe had deton. Tyler (Ref 11) reports an expln resulting from the ashing of animal tissue in a closed container with a mixt of fuming sulfuric and nitric acids

Other workers have reported on expts designed to investigate the conditions required for explns with sulfuric acid. Taradoire (Ref 2) added a drop of the acid to 0.5g of a mixt of S and the chlorates of K, Ba or Pb. He reports that the highest concn (C) at which no expln occurred after 24 hrs at 22° , was for anhydr K chlorate, C=47% (94.9% acid produced no expln, although weaker acid did); for Ba chlorate. H_2O , C=34.5%; for Pb chlorate. H_2O , C=1.0%. Taradoire concludes that expln results from both the chem effect of the decompn products of H chlorate and the sudden heat produced by the reaction. Androsov et al (Ref 15), in reporting on the catalytic effect of sulfuric acid on the combustion rate and temp rise during flash ign of NC, states that the acid increases the decompn rate up to 250° and concluded that this is because sulfuric acid accelerates NO_2 cleavage from the NC molecules

The prime Ordn use for sulfuric acid is in the mixed nitric-sulfuric acid used in the mixed acid nitration of raw materials to form explns and proplnts. The techniques and procedures are presented in Vol 2, C101-R to C103-L under "Preparation of NC's"; in Vol 3, C501-L to C510-L under "Continuous Methods for Manufacturing Explosives"; in Vol 6, G98-R to G103-R under "Glycerol Trinitrate or Nitroglycerin (NG)"; and in Vol 8, N40-R to N88-R under "Nitration"

According to Ellern (Ref 5) the use of sulfuric acid in some incendiary pyrots is a neces-

sity because ". . . there are systems which are non-corrosive and relatively harmless in themselves. These systems can be reliably brought to flaming by the addition of concentrated sulfuric acid, which liberates the active acid from its salt. The most common combinations are those of potassium chlorate with sugar or nitrobenzene. The reacting substances will burst into flame on the addition of a few drops of sulfuric acid, or will explode violently if mercury fulminate is present. Such mixtures have been used frequently as incendiaries for sabotage and in bombs. Their advantage as incendiaries lies in the fact that the reaction can be delayed for hours, days, or weeks by making use of the corrosive action of the acid to work its way thru some barrier

In another setup, the acid gains in volume by absorbing moisture from the air. This leads eventually to a siphoning action into the active material. The diluted acid will react with the chlorate though more slowly than it does in the concentrated state. Similar contraptions utilize tilting and spilling to bring acid and chlorate together . . .". Ellern also points out that (from p 52) ". . . Concentrated sulfuric acid will also activate the permanganate combinations with the combustibles, producing a violent reaction. The liberation of the manganese heptoxide, Mn_2O_7 , and the formation of ozone, make this reaction so energetic in character . . ."

"How to" books of clandestine devices (Refs 16, 16a and 16b) illustrate in explicit detail how to use sulfuric acid with K chlorate and sugar or match heads to form incendiary delays involving sulfuric acid consumable barriers such as paper, plastic or rubber, and provide an erratic time to ignition dependent on weather conditions, barrier thickness and matl. Ignition of blasting caps, etc is also performed in a "do it yourself" manner with a medicine dropper, rubber prophylactic, and a small amt of battery acid. In fact, ref 16 describes a "Chemical Fire Bottle" using sulfuric acid and gasoline mixt in a sealed bottle wrapped in a K chlorate and sugar impregnated cloth. This species of "Molotov Cocktail" is activated by breaking the bottle against a hard surface

A recent usage of the techniques indicated above is indicated by the identification of terrorist incendiary devices reported by Gomez

and Palacio (Ref 18). Incendiary bombs placed in Columbian comml and public buildings consisted of a mixt of K chlorate, S, and sucrose in a cigarette package along with a plastic-wrapped methyl cellulose capsule of concd sulfuric acid. In use the packets are taped to the target areas. It is reported that after 30–40 mins the liberated acid ignited the incendiary mixt. Also reported were similar bombs containing a mixt of K chlorate, Na nitrate, and sugar together with smaller amts of powdered Al, powdered Sb, gasoline and petr jelly, which were ignited using the sulfuric acid ignition technique already described

According to Sax (Ref 8) sulfuric acid is an exceedingly dangerous, caustic material. It "... May cause death or permanent injury after very short exposure to small quantities ...". The threshold limiting value of respiratory exposure is 1 mg/cm of air. In the (breathable) atmosphere, ... 0.125 to 0.50ppm may be mildly annoying and 1.5 to 2.5ppm can be definitely unpleasant; 10 to 20ppm is unbearable ...". Body contact results in rapid de-

struction of tissue and severe burns. When heated, sulfuric acid releases highly toxic fumes of SO_3 ; it can react vigorously with both oxidizing or reducing materials. If one adds w to acid (instead of vice versa) the enormous amt of heat evolved will cause a species of expln and result in the spattering of this corrosive liq

The US Federal Specification for technical grade sulfuric acid (Ref 7) contains the following requirements:

- 1) Classification. Type I – 66° Baume; Type II – 60° Baume. Each type is further subdivided into two classes; Class 1 and Class 2 – both can be used for military purposes;
- 2) Appearance. Sulfuric acid shall be oily, a clear to sl cloudy liq when visually examined; and
- 3) The chemical and physical requirements for sulfuric acid are presented in Table 1

Refs: 1) Gmelin, Syst Nr 9, Teil B (1960), 613–24 2) F. Taradoire, "Action of H_2SO_4 on Mixtures of S and Chlorates", BullSocChim 9, 610–15 (1942) 3) H. Cohen, "Sulfuric Acid Explosion", CE&N 29, 1770 (1951) & CA 46, 3279 (1952) 3a) N.H. Furman, "Stan-

Table 1
Physical and Chemical Requirements of Sulfuric Acid

Characteristic	Requirement				Applicable Footnote
	Type I		Type II		
	Class 1	Class 2	Class 1	Class 2	
Sulfuric acid, percent by weight, min	93.0	93.0	77.5	77.5	a
Specific gravity at 60°/60°F, min	1.8347	1.8347	1.7040	1.7040	b
Nonvolatile matter, percent by weight, max	0.025	0.025	0.05	0.05	c
Arsenic, parts per million (ppm) max	2.5	--	2.1	--	d

Footnotes to Table 1:

a—by the total acidity method of ASTM-E-223-64

b—by the Baume gravity procedure of ASTM-E-223-64

c—by the nonvolatile procedure of ASTM-E-223-64

d—by nitration-oxidation-evapn of a 200g sample to 15cc, and then cooling and diluting with 20ml of w followed by evapn to 10ml and (after cooling), making up to 50ml. 25ml of this soln is then subjected to a modified Gutzeit procedure as described on pages 118–124 of Ref 3a. The technique involves staining sensitized paper with the arsenious acid formed from the sample and comparing with various standard strengths of stains

ard Methods of Chemical Analysis", Vol 1, 6th Edn, D. Van Nostrand, NY (1962), 118-24

4) A. Schrieber, "Sulfuric Acid Explosion", *CE&N* **30**, 707 (1952) & *CA* **46**, 5319 (1952)

5) Ellern, "Pyrotechnics" (1961), 51

6) J.J. Lagowski, Ed, "The Chemistry of Non-Aqueous Solvents", Vol II, Academic Press, NY (1967), 99-150

7) Anon, "Federal Specification, Sulfuric Acid, Technical", **O-S-809b** with Amend-1 (1968)

8) Sax (1968), 1129-30

9) A. Senning, "Sulfur in Organic and Inorganic Chemistry", Vol 2, Dekker, NY (1972), 71-110

10) Hackh's (1972), 648

11) L. J. Tyler, "Sulfuric Acid + Nitric Acid + Fat = Danger", *CE&N* **1973**, 51 (31), 32 & *CA* **79**, 91085 (1973)

12) Anon, "Fire Protection Guide on Hazardous Materials-6th Edn", NFPA, Boston (1975)

13) Bretherick (1975), 792-96

14) Merck (1976), 1163 (No 8769)

15) A.S. Androsov et al, "Study on the Effect of Catalysts on the Detonation of Explosives for an Investigation of Their Behavior During Combustion", *FizGoreniyaVzryva* **1976**, 12 (2), 197-202 & *CA* **85**, 80482 (1976)

16) Anon, "Improvised Munitions Black Book", Vol 2, Desert Publications, Phoenix (1977), Sect V, No's 1, 4.5 & 5

16a) Anon, "CIA Field Expedient Incendiary Manual", Desert Publications, Phoenix (1977), 5, 39, 40, 47, 48

16b) Anon, "CIA Improvised Sabotage Devices", Desert Publications, Phoenix (1977), 63-64

17) *CondChemDict* (1977), 827

18) P.T.E. Gomez & A.M. Palacio, "Identification of Incendiary Bombs", *RevInstNacMedLegColomb* **1977**, 2 (1), 101-06 (Span) & *CA* **88**, 76089 (1978)

Sulfur Nitride. See in Vol 8, N102-L to N103-L

Sulfur-Saltpeter [Soufre-salpetre (Fr) and Saltpeter-Schwefelmengung (Ger)]. Mixts of 1 p S and 1 or 3p of K nitrate used in various pyrots in both Fr and Ger
Ref: Daniel (1902), 728

Sulfurite. A mining expl patented by Sala and Azémar in Fr in 1889 contg K nitrate 62, sulfur 30, charcoal 4 and woodash 4%
Ref: Daniel (1902), 746-47

Sunflower Stalks. Were suggested as an ingredient of low d Dynamites, the other ingredients being NG, AN, Na nitrate, Na chloride, combustibles, etc

Ref: H.A. Lewis, CanP 340566 (1934) & *CA* **28**, 4234 (1934); USP 1992189 (1935) & *CA* **29**, 2745 (1935)

Sunlight, Effect on Explosives. See under "Light, Effect on Explosives" in Vol 7, L14-L to L14-R

Super-Ammodyne. Brit permitted expl which passed the Buxton test: NG and Nitroglycol 9, AN 70, woodmeal 8, Na chloride 8 & amm oxalate 5%; Bal Pend swing 2.80"
Ref: Marshall **3** (1932), 120

Supercharge. Propelling charge intended to give the highest standard muzzle velocity, authorized for the projectile in the weapon for which intended. The term is sometimes used as an identifying designation when more than one type of propelling charge is available for a weapon
Ref: Anon, Ordn Tech Term (1962), 295-R

Supercord. Trade name of a detonating cord contg about 40g PETN/m distributed in the Ger Federal Republic by Dynamit Nobel. It is covered with red colored plastic, and serves for the initiation of ANFO blasting agents and for smooth blasting
Ref: R. Meyer, "Explosives", Verlag Chemie, NY (1977), 254

Super-Excellite 4. Brit permitted expl contg NG 8.5-10.5; AN 62.0-65.0; woodmeal dried at 100°, 4.5-6.5; Na chloride 18.5-20.5, and Mg carbonate 0.0-1.5%
Ref: Naoúm, NG (1928), 444

Super Gel A; Gel B. Trade names of gelatinous and semigelatinous permitted expls distributed in the USA by Trojan-U.S. Powder:

	Density, g/cc	Wt of 1¼ by 8" cartridge gms	No of 1¼ by 8" cartridges in 50lb case
Super Gel A	1.41	227	100
Gel B	1.13	182	125

Ref: R. Meyer, "Explosives", Verlag Chemie, NY (1977), 255

Super Gun. The most spectacular gun developed by Ger during WWII was Hochdruckpumpe (HDP), super gun, which was designed to fire an arrow projectile across the channel at London. It was a 15cm gun made up of 40 sections with

28 powder chambers distributed along the bore, so as to give successive explns to boost the projectile as it progressed along the tube (Fig 1)

It had a muzzle velocity of 4500fps and fired a 150 lb projectile which was 8 ft long (Fig 2)

A five tube battery was being constructed underground at an angle of 50° near Calais to fire on London, but it was bombed before completion. It had a range of about 130km. Its tests were regarded as successful although the barrel expld about once in every three shots. Since the barrel was made up in sections, it was planned to merely replace the blown-up section, and crews were trained to do this quickly

Whereas the principle of the long, slender fin-stabilized projectile was considered sound,

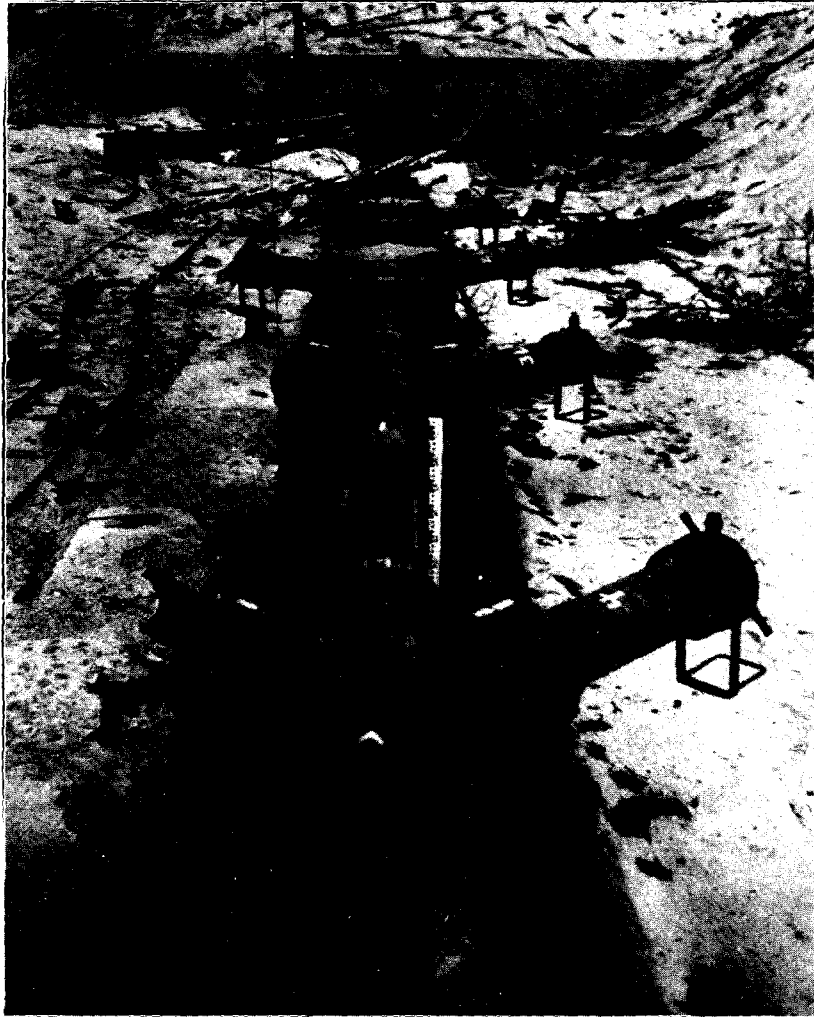

Fig 1 THE HDP SUPERGUN looking toward the breech. Charges of propellant powder were set off successively in the booster chambers as the projectile passed along the bore.

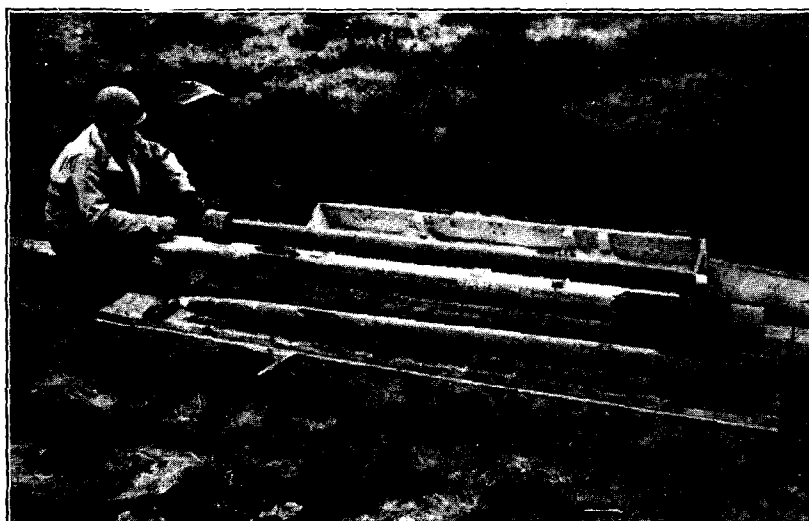

Fig 2 ARROW PROJECTILES FIRED BY THE HDP SUPER GUN
to a range of approximately 80 miles

no good results were expected from the multiple powder chamber, even by the people who were working on the development of the gun

Ref: L.E. Simon, "German Research in World War II", J. Wiley & Sons, NY (1947), 191-93

Super Kolax. Brit expls of the Carbonite type (see Vol 2, C61-R) which contained amm oxalate as a cooling agent in order to pass the Buxton test. A typical formulation consisted of NG 25.5, K nitrate 25.5, Ba nitrate 5.0, woodmeal 30.0, starch 7.0 and amm oxalate 7.0%

Ref: Marshall 1 (1917), 376

Super-nitrated Liquids. A.E. Vergé, in a 1913 Engl patent (Refs 1 & 2), claimed that "super-nitrated liquids are obtained by dissolving suitable amounts of pure or commercial solid TNT (mp 82° or 70-72°, respectively) in the liquid mixtures of dinitro compounds; by nitrating in the usual manner the liquid dinitro compounds and dissolving certain quantities of these trinitro compounds in the liquid dinitro compounds; by nitrating a mixture of solid TNT and m-nitrotoluene containing the necessary proportions of the o- and p-nitrotoluenes; by nitrating the mixture of mononitrotoluenes in such a manner as to produce directly the desired amount of trinitrotoluenes. This last method is not recom-

mended, as it requires a higher temperature and always entails a loss of the product by oxidation. By these methods it is possible to obtain a series of liquids containing up to 16% nitrogen, which show no appreciable loss or change after heating at 60°C for 24 hours"

Refs: 1) A.E. Vergé, EngP 17128 (1913)
2) Colver (1918), 683-84

Supernapalm. A napalm formulation which contains a self-igniting light metal compd. This removes the need for a separate ignition system, and is said to ignite equally well on snow or w
Refs: 1) A. Naerland, "Napalm", Norsk Militær Tidsskrift 7, 359-66 (1967) 2) Anon, "Incendiary Weapons", SIRRI Monograph, The MIT Press, Cambridge, Mass (1975), 95

Superquick Fuze. A type of impact fuze using a nose striker to cause the fuze to function almost instantaneously upon impact. Also called an "instantaneous fuze"

See also under "Fuzes" in Vol 6, F255-L ff
Ref: J. Quick, "Dictionary of Weapons and Military Terms", McGraw-Hill, NY (1973), 428

Superoxides. See under "Peroxides" in Vol 8, P184-L to P209-L

Super-Rippite. A gelatin coal mining expl which was on the Brit "Permitted List". It contained NG 51-53, collodion cotton 2-4, K nitrate 13.5-15.5, borax (dried at 100°) 15.5-17.5, K chloride 7-9, and H₂O (total) 5-8%; BalPend swing 2.53"; limit charge 18 oz (Ref 1)

Ref 2 describes *Super-Rippite No. 2* as a perchlorate expl, which was on the Brit "Permitted List" between WWI and WWII, and passed the Rotterdam Test. It contained NG 52, collodion cotton 3, K perchlorate 11, amidocomp 0.3, borax 23.7, & K chloride 10%. Its limit charge was 26 oz, and strength (swing of BalPend) was 2.49" (against 3.27" for Brit 60% Gelnite)

Refs: 1) Barnett (1919), 136-37 2) Marshall 3 (1932), 113

Suppressive Shielding. See under "Materials of Construction in Ammunition Plants" in Vol 8, M42-R to M45-L

Suppressor, Flash. See under "Flash-Reducing (or Antiflash) Agents" in Vol 6, F96-L to F100-L, and "Flash Hider or Muzzle Flash Suppressor" in Vol 6, F77-L

Addnl Refs: 1) Anon, EngrgDesHndbk, "Spectral Characteristics of Muzzle Flash", AMCP 706-255 (1967) 2) Anon, EngrgDesHndbk, "Guns Series-Muzzle Devices", AMCP 706-251 (1968)

Surveillance. Includes the observation, inspection, investigation and test (ballistic, chemical and physical) of expls and ammo in storage, transit and use. The purpose of surveillance is to protect the expls and ammo (including components) from conditions tending to increase deterioration or danger; to determine the state and nature of deterioration and degree of serviceability; to detect dangerous conditions, thereby preventing, or lessening the danger of disaster thru accidental burning or expln of such substances which have become seriously unstable

For specific tests relative to expls and proplnts, see under "Stability of Explosives and Propellants, Determination of" in this Vol, and "Compatibility of Explosives with other Substances" in Vol 3, C461-L to C462-L

Susan Sensitivity Test. See in Vol 4, D334-L to D335-R for earlier treatment on this subject. The following update information is taken from B.M. Dobratz, "Properties of Chemical Explosives and Explosive Simulants", UCRL-51319, Rev 1, Lawrence Livermore Lab, Univ of Calif (1974), 9-3 to 9-21:

The Susan Sensitivity Test (Ref 7) is a projectile impact test with the projectile shown in Fig 1. The wt of expl in the projectile head is about 1 lb (0.45 kg). The target is armor-plate steel. The results of the tests are expressed in

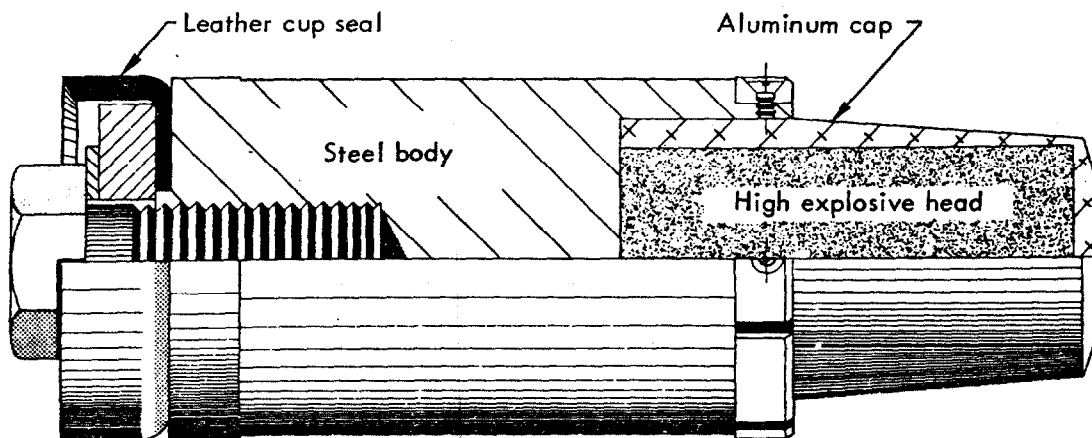

Fig 1 The Susan projectile. Scaled drawing; the high explosive head is 4" long by 2" in diameter (0.102m x 0.051m)

terms of a "sensitivity" curve in which the relative "point-source detonation energy" released by the expl as a result of the impact is plotted against the velocity of the projectile. The relative point-source detonation energy can be derived from a transit-time measurement of the air shock from the point of impact to a pressure gauge 10 ft (3.1m) away. The results determined in this manner are somewhat subjective, particularly when the reaction level shows a large but relatively slow increase with time. The preferred way to get at the "point-source detonation energy" at present is to relate it to the overpressure measured 10 ft (3.1m) from the impact. This results in much more reproducible data and is not subject to many of the errors of the transit-time measurements

On the Figs which follow the energy scale has been set to range from zero for no chemical reaction to approx 100 for the most violent detonation-like reactions (all expl consumed) for the most energetic expls. Less violent burning reactions that appear to consume all of the expl can give values on the scale as low as 40; the energy equivalent of TNT fully reacted as a point source, would register at 70 on the scale. For each expl considered, comments are made on the details of the impact process that seem to bear on the impact safety of an expl. Remarks about probabilities of large reactions are relevant to unconfined charges in the 25-lb (11.3-kg) class. Smaller unconfined charges show a trend of decreasing reaction level as the charge size gets smaller

References to the "pinch" stage of the impact refer to the terminal stage when the nose cap has been completely split open longitudinally and peeled back to the steel projectile body, which is rapidly being brought to a halt

TNT

TNT shows no undesirable properties by the Susan test (Fig 2). Minor ignitions are seen down to about 235ft/sec (72m/s) impact velocity but only after extensive splitting of the projectile nosecap and abrupt halt of the projectile at the final or "pinch" stage of impact. No violent reactions are observed even at impact velocities above 1200ft/sec (366m/s). Further, the TNT response is independent of whether it is cast or is a high- or medium-density pressing. TNT should be considered very difficult to ignite accidentally by mechanical means; any reaction from such an ignition should be regarded as having an extremely

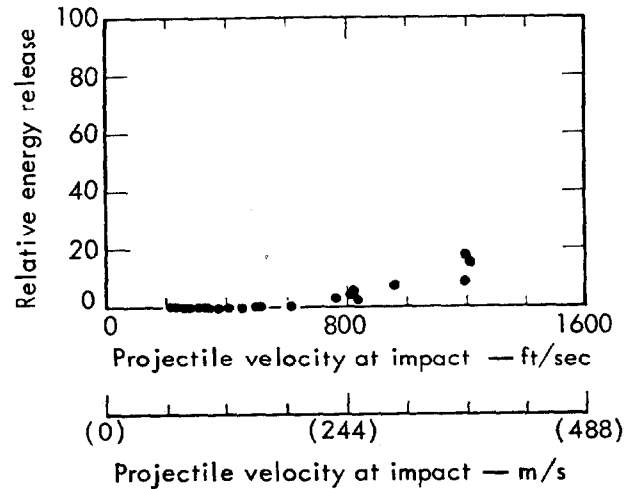

Fig 2 Susan Test: TNT. Conversion factor:
1 ft/sec = 3.048×10^{-1} m/s

low probability of building to violent levels where there is relatively little confinement

Cyclotol 75/25

Cyclotol 75/25 (RDX/TNT 75/25) has both good and bad properties as measured by the Susan test (Fig 3). The threshold velocity for reaction is probably about 180ft/sec (55m/sec), which is rather typical of the TNT-bonded cast expls and higher than most plastic-bonded expls. On the other hand, reaction levels generally are moderately high at relatively low velocity and on occasion are considerably higher. Cyclotol 75/25 should be considered as generally rather difficult to ignite by mechanical means but capable of a large reaction once ignited

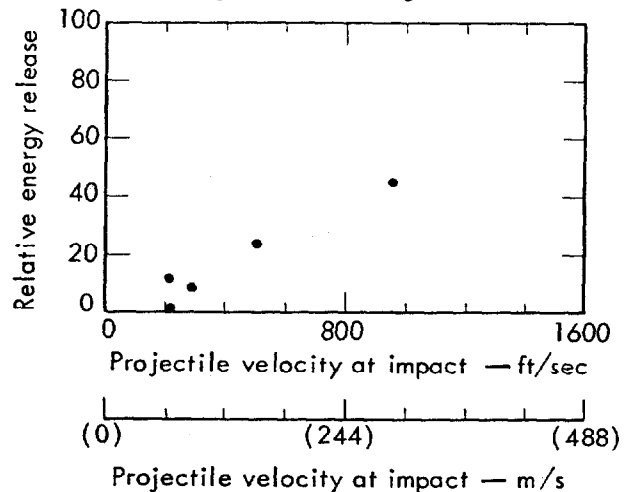

Fig 3 Susan Test: Cyclotol 75/25. Conversion factor: 1 ft/sec = 3.048×10^{-1} m/s

Comp B-3

Comp B-3 (RDX/TNT 60/40) behaves reasonably well in the standard Susan test (Fig 4). Ignition is observed only after extensive splitting and deformation of the projectile nose cap, more or less at the beginning of the "pinch" stage of impact. This results in a threshold velocity of about 180 ft/sec (55m/sec). The reaction level is quite dependent on impact velocity; it never rises to its full potential even at an impact velocity of 1500 ft/sec (457 m/sec). Any reaction enhancement is seen quite soon after initial ignition. Comp B-3 should be considered as generally rather difficult to ignite by mechanical means and as having a low probability for violent reaction once ignited, provided the relative confinement is rather low. It has given substantially larger reactions in the Mod-IA projectile than in the standard Mod I; the important difference between the two projectiles appears to be the exceptionally straight flight of the Mod-IA, which results in higher pressures on the expl and more effective confinement. Comp B-3 has been observed to detonate in impact geometries where there was good inertial confinement at the time of ignition, and where it has been subjected to mechanical work by the impact

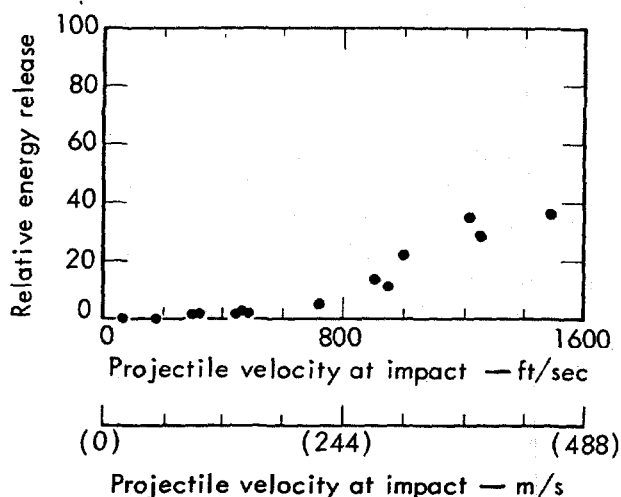

Fig 4 Susan Test: Comp B-3. Conversion factor: 1 ft/sec = 3.048×10^{-1} m/s

Octol 75/25

Octol 75/25 (HMX/TNT 75/25) has both good and bad properties as measured by the

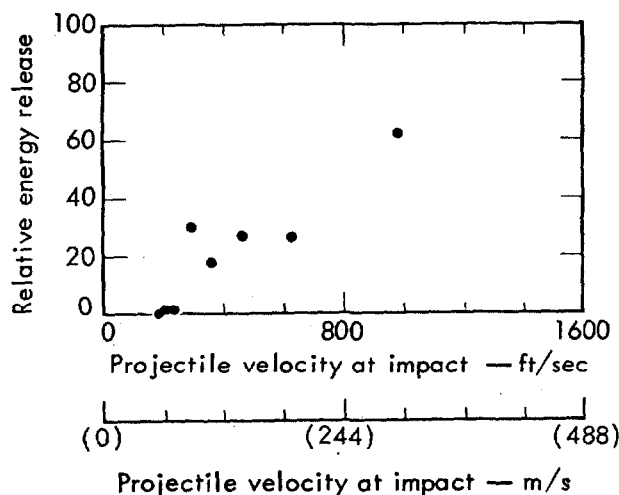

Fig 5 Susan Test: Octol 75/25. Conversion factor: 1 ft/sec = 3.048×10^{-1} m/s

Susan test (Fig 5). The threshold velocity for reaction is probably about 180ft/sec (55m/s), which is rather typical of the TNT-bonded cast expls and higher than most plastic-bonded expls. On the other hand, reaction levels become moderately high, generally at relatively low velocity. The variability of results is less than that observed with Cyclotol 75/25. Octol 75/25 should be considered as rather difficult to ignite accidentally by mechanical means but capable of a large reaction once ignited under certain conditions

Ref: A.M. Weston & L.G. Green, "Data Analysis of the Reaction Behavior of Explosive Materials Subjected to Susan Test Impacts", UCRL-13480, Lawrence Livermore Lab, Univ of Calif (1970)

Swale Powder. A perchlorate expl, at one time on the Brit "Permitted List". It contained K perchlorate 37.5, NG 19, collodion cotton 1, TNT plus DNT 4, woodmeal 9, amm oxalate 28, and H₂O 1%. BalPend swing 2.50", limit charge 20 oz

Refs: 1) Marshall 1 (1917), 385 2) Barnett (1919), 137

Swalite. Brit expl similar in compn to the "Samsonites" (qv in this Vol)

Ref: Marshall 1 (1917), 374

Swatter. NATO code-name for a Soviet anti-tank missile which is also known by the US alphanumeric designation **AT-2**. It is an MCLOS (manual command to line-of-sight) vehicle-mounted system and is unusual in that radio command guidance is used, there being two radio frequencies on the command link

Wt at launch, 26.5kg; length, 1130mm; diameter, 130mm; rocket motor, solid; control, control surfaces on fins; warhead, HEAT with DA fuze; range, 600–2500m; and penetration, 400mm+

Swatter is in service with USSR and Warsaw Pact armies and in Egypt and Yugoslavia

Refs: 1) M.J.H. Taylor & J.W.R. Taylor, "Missiles of the World", Charles Scribner's Sons, NY (1976), 144 2) D.H.R. Archer, Ed, "Jane's Infantry Weapons, 4th Ed, 1978", Franklin Watts, NY (1978), 617–18

S- and SS-Waves. See under "Damage Potential of Air and Ground Blast Waves" in Vol 3, D3-R to D4-L

Sweating. (Schwitzverfahren in Ger). A process which might be considered as the inverse of crystallization, that serves for the separation of low melting impurities from the higher melting bulk of crystals. It is done as follows: the material to be separated is run in the molten state into a jacketed vessel called a "sweat pan", which is provided with a bottom draw-off. The mass is cooled by means of cold liq circulating thru the jacket until the entire mass is frozen solid. Then, circulation of the cooling liq is stopped, and heating liq is circulated instead. At the same time, the bottom draw-off is opened and, as soon as the freezing pt of the lower melting fraction (which is a eutectic) is reached, the liq at the bottom of the sweat pan starts to run thru the draw-off, freeing the drainage space to receive the "sweating" from the crystals above. The temp is gradually raised until it reaches as close to the freezing pt of the higher melting constituent as is necessary for the degree of purity required

The "sweating" process has been used in the expls industry in Europe, eg, for the separation of ortho- and paranitrotoluenes, ortho- and

paranitrobenzenes, dinitrotoluenes (see under "Drip-Oil" in Vol 5, D1546-L to D1547-L), etc

Accd to Colver (Ref 1), the purification of *Di-Oil* (crude DNT) was conducted in Italy during WWI as follows: after separation from spent acids, the *Di-Oil* was allowed to crystallize in fairly large crystals; but before the entire mass became completely solid, it was broken up and centrifuged at about 40°. This process might be considered as "sweating" combined with centrifuging. In order to remove all of the oily ingredients as thoroughly as possible, a quantity of warm (about 40°) w was fed into the centrifuge, sometimes with the broken-up DNT. Insofar as is known, the Italians used the same process during WWII

Refs: 1) Colver (1918), 204 2) Stettbacher (1933), 265

SWEDISH EXPLOSIVES

The expls industry of Sweden dates back from the year 1540. For over 300 years, the manuf of expls was limited to BlkPdr and similar compns. The inventions of Alfred Nobel (see Vol 8, N165-R to N167-L), of various Dynamites, in the 1860–70's, soon led to the emergence of a modern expls industry. By 1900 all of the firms, which are major producers today, had been established

The industrial and military expls industry of today consists of both private and government owned facilities. Together they provide virtually all of the country's expls, plus significant amounts for export. The only items obtained abroad are initiating components such as Primers and Detonators. Sweden, however, is heavily dependent on imports for certain basic raw materials such as petroleum, coal, coke, cotton, sulfur, and others

Commercial expls are used extensively for mining, excavating, and road building. Also large quantities are used in excavation for underground shelters and other facilities. Dynamites are also used by the military forces as standard Demolition Charges. A broad range of military expls is currently being produced. These include TNT, RDX, PETN, Composition B, Torpex, BlkPdr, Pb Azide, Pb Styphnate, MF and all types of proplnts

There are seven significant producers of expls and related items. Three of the plants are government owned, and are located in southern Sweden. The largest individual producer of military expls is *AB Bofors Nobelkrut*, a division of AB Bofors of Karlskoga. *AB Nitroglycerin* in Gyttop is the principal producer of commercial expls. *Åkers Krutbruk* in Åker is the only government plant which manufs bulk expls

The principal expls known to be manufd and used in Sweden, according to available native nomenclature, are listed alphabetically below:

Ammongelatin Dynamit (Gelatin Dynamite). This type of expl was invented in 1879 by A. Nobel. One formulation contains NG 71, colloid cotton 4, AN 23, and charcoal 2%. Another contains NG 25, colloid cotton 1, AN 62, and charcoal 12%. The first compn is gelatinous, while the second is crumbly and plastic

The basic formulations may be and have been changed by incorporating other expls such as liq DNT, TNT, Trinitroxylyene, Nitrostarch or Nitroglycols. Such additives act not only as sensitizers for AN, but some also serve as anti-freeze compds

This Dynamite is used for general blasting and demolition operations

Dynamites similar to *Ammongelatin Dynamit* are manufd in the USA by DuPont under the name *Extra Dynamite*

Ammoniakkrut (Ammonium Nitrate Dynamite). This expl, invented in 1876 by Swedish chemists C.J. Ohlsson and J.H. Norrbin, consisted of AN 80 and charcoal 20%. Such a mixt is the first known expl based on AN. The original mixt was difficult to initiate and was replaced by Nobel by one consisting of AN 80, NG 12 and charcoal 8%

The modified Ammoniakkrut has been used to some extent in Sweden, but was found to be too hygroscopic and exudable

See also in Vol 1, A306-R

Blastin (Cheddite). A safety expl consisting of amm perchlorate 63, Na nitrate 23, DNT 8, and paraffin wax 6%. It is reported to be 50% more powerful than Dynamite, and has been used extensively as a blasting and demolition expl

Blyazid or Blyacid (Lead Azide). Replaced MF in detonators for military ammo and in commercial blasting caps. It is not used in Cu or brass primers or fuzes because of its tendency to form the highly sensitive Cu azide. For purposes where a higher sensitivity is desired, Pb Azide is covered with a layer of Pb Styphnate, or used with this more sensitive initiator. Pb Azide is used in both pure and dextrinated form

Blystyfnat or Blytrinitroresorcinat (Lead Styphnate). Used as a cover charge for Pb Azide, as a primary initiator in bridge-wire detonators, and in various priming compns required to have certain blast characteristics

Bonit (Cyclotol). Name applied to Swedish military expls developed by AB Bofors Nobelkrut. The following mixts were used before WWII:

Bonit 1. RDX 50 and TNT 50%. Loading d, 1.68g/cc; vel of deton, 7600m/sec; heat of expln, 1130cal/g

Bonit 2: RDX 70 and TNT 30%. Loading d, 1.70g/cc; vel of deton, 7800m/sec; heat of expln, 1225cal/g (TNT=850); gas vol at NTP, 950 l/kg (TNT=630); relative brisance, 136% (TNT=100); and Trauzl test value, 621cc (TNT=290)

Bonit 3. RDX 60 and TNT 40%. This is the usual and most common mixt used. Its properties are intermediate between those of Bonit 1 and Bonit 2. See also *Hexotol* in this section

Bonit was used as an underwater military bursting charge and as a bursting charge in shells. During WWII, Al powder was incorporated to increase its effectiveness (see *Hexotol* in this section)

See also in Vol 2, B242-R

Bonocord (Detonating Fuse, Primacord). The Swedish detonating cord consists of a PETN core, covered with braided cotton threads, and protected by an outer coating of a plastic which is based on polyvinyl chloride or polyethylene. The quantity of PETN is 12g/m; the total wt of Bonocord is 30g/m, and its outer diameter is 5.5mm. It has a deton vel of 6000–7000m/s, is initiated with a No 6 Exploder, and is used for direct detonation of all types of expl charges

Dynamex A and B. Trade names of gelatinous

expls distributed in Sweden by Nitro Nobel: d 1.4g/cc; wt strength A, 80, B, 78%

Dynamit (Dynamite). Dynamites with active bases, now called "Straight Dynamites" and which correspond to present formulations, were first prepd by A. Nobel in 1869. Nobel coated the particles of a mixt of oxidizers (K, Na or amm nitrate) and solid combustibles (such as woodmeal, charcoal, rosin, starch or sugar) with NG. The patent suggested a mixt of Ba nitrate 70, rosin or charcoal 10, and NG 20%. Sulfur could be either added or omitted

When Na or amm nitrate was used, it was suggested that the particles be coated with small amounts of paraffin, ozokerite, stearine, naphthalene or other similar substances, in order to reduce the hygroscopic nature of the oxidizer

A variety of Dynamite compns are manufd in Sweden by AB Bofors Nobelkrut at Karlskoga, by Nitroglycerin AB at Gyttrop, by AB Norma Projektilfabrik at Amotfors, by AB Nora Tändröfsfabrik at Nora, by AB Svenska Krutfaktorierna at Landskrona, and probably at other facilities

Flegmätiserat Sprängämne (Phlegmatized Explosives). This name is applied to Swedish expls which have been phlegmatized (desensitized) by coating the granules with wax. The desensitizing wax used is a white, semi-transparent, highly refined petroleum paraffin

Gelatinerad Dynamit (Gelatin Dynamite). This expl was invented in 1875 by A. Nobel. He dissolved small amounts of collodion cotton in slightly warmed NG and incorporated into the resulting soft jelly some BlkPdr, saltpeter (K nitrate) or woodmeal. A typical Dynamite contained NG 62.5, collodion cotton 2.5, K nitrate 27, and woodmeal 8%. Present commercial Gelatin Dynamites are essentially unchanged from the original inventions of Nobel, except that BlkPdr as such is not added

Gurit. Trade name of a special expl for smooth blasting and presplitting distributed in Sweden by Nitro Nobel. It is cartridged in small diameters (11 & 17mm) and 460mm lengths, and is provided with extension and locking sleeves

Hexogen (RDX). Due to its properties, which have been thoroughly investigated in Sweden, RDX is used primarily with other expls to form mixts that can be either pressed or cast as safely as TNT. The principal compns are *Hexotol*, *Bonit* and *Hexatonal*

Hexotol (Cyclotol). The name applied to the usual and most common mixt of RDX and TNT (60/40). It is prepd in the form of beads, pellets, flakes or granules. It is also called *Bonit 3*

Hexotol is used as a cast bursting charge in shells, land mines, demolition charges, boosters, and in other military applications

See also in Vol 7, H94-L

Hexotonal (Torpex). This name is applied to several castable expls developed by AB Bofors Nobelkrut. They are usually prepd by adding small proportions of wax, carbon black in some formulations, and Al powder to 60/40 or 50/50 *Hexotol (Bonit)*. Some examples of known compns are as follows:

a) RDX 40, TNT 44, Al 15 and wax (highly refined petroleum paraffin) 1%; b) RDX 40, TNT 40, Al 15 and wax 5%; and c) RDX 30, TNT 50, Al 20, plus 1% wax and 1.5% carbon black

Hexotonals were used during WWII as very effective underwater military expls. At present these expls are used as bursting charges in many types of ammo

See also Vol 7, H94-L

Knallkvicksilver (Mercury Fulminate). See in Vol 6, F217-L to F223-L

Nabit A. Trade name of a powder form industrial expl distributed in Sweden by Nitro Nobel: d 1.2g/cc; wt strength 75%

Nitrocellulosa (Nitrocellulose). See in Vol 2, C100-L to C125-R

Nitroglycerin. See in Vol 6, G98-R to G108-L

Nobelit. A permissible Gelatin Dynamite consisting of NG 28, collodion cotton 1, AN 40, combustibles (flour, woodmeal, dextrin) 13.5, Na chloride 17 and vegetable oil 0.5%

See also in Vol 8, N168-R

Nonel. Trade name of a new "non-electric" device for the firing of expl charges. The basic unit consists of, in place of electrical lines, safety fuses or detonating cord, a plastic hose (3mm diam) the inner wall of which is coated with a thin layer of expl. A shock wave initiated by a special initiator passes thru the hose with a speed of approx 2000m/sec. A spectator observes this shock wave process as a flash in the hose, which is not destroyed by the shock wave

In order to initiate a charge, the Nonel line must be combined with a conventional detonator, and branching is possible

The device was developed and is distributed by Nitro Nobel, Sweden. Its application is of interest in electrically endangered (by thunderstorms, stray currents, etc) areas

Novit. See in Vol 8, N172-L

Pentyl (PETN). Obtained as non-hygroscopic, colorl, prismatic crystals melting at 142°; the technical grade melts at 140–41°

Aside from NG and NC, PETN is considered the most important of the nitric esters in the expl field. In the pure state, PETN is used to form the core of *Bonocord* (detonating cord) and is used as a base charge in blasting caps. In admixts with NG, PETN is used in a variety of industrial expls called *Pentrinitis*. PETN desensitized with wax is used as a bursting charge for shells, boosters and demolition block. With the addition of special ingredients, PETN forms plastic expls called *Sprängdeg*

Pikrinsyra (Picric Acid). See in Vol 8, P285-R to P296-L

Pyroteknik (Pyrotechnics). A brief description of the historical development of pyrots in Sweden is given by A. Lotz, "Das Feuerwerk", Hiersemann, Leipzig (1940), 106 ff

Reolit A, B, C, D or E. Trade names of slurry blasting expls distributed in 45kg bulk packages or in 650kg bulk shipment by Nitro Nobel in Sweden. Reolit E has a lower d than the other types

Reomex A or B. Trade names of slurry blasting expls loaded in plastic hoses, distributed in

Sweden. Reomex A has a d of 1.2g/cc with a wt strength of 80%; Reomex B has a d of 1.1 g/cc with a wt strength of 57%

Seramin (Ammonium Nitrate Dynamite). Soon after the invention of the Swedish expl *Ammoniakkkrut* (qv in this section), Bjoerkmann patented (June 1867) a blasting expl consisting of AN 72.5, NG 18, sawdust or charcoal 8.7, and benz or creosote 0.8%. Seramin, like the modified *Ammoniakkkrut* contg NG, was more powerful than the Guhrdynamite invented earlier by A. Nobel

Sprängämnen med Minverkan (Demolition Explosives). See *Ammongelatin Dynamit, Blastin, Dynamit, Gelatinerad Dynamit, Nobelit, Seramin, Spräng gelatin, Territ*, etc

Sprängdeg (Plastic Explosive). Name applied to Swedish plastic expls, usually contg RDX or PETN which have been desensitized with oil and special plasticizers

A Bofors Plastic Explosive consists of PETN 84 and mineral oil 16%, mixed by a special procedure. The product is a yel plastic dough having a bulk d of 1.45g/cc. It is moldable even at temps below -15°, and is of the same order of stability as cryst PETN

Spränggelatin (Blasting Gelatin). Invented in 1875 by A. Nobel. It is prepd by dissolving 7–8% of collodion cotton in slightly warmed NG. The resulting product on cooling is a stiff jelly. It is one of the most powerful expls known, even today. See also *Gelatinerad Dynamit* in this section

Startex A. Trade name of a slurry blasting agent loaded in plastic hoses, distributed in Sweden by Nitro Nobel; d 1.5g/cc, wt strength 72%

Svartkrut (BlkPdr). For most types of Swedish BlkPdr, the compn falls within the following limits: K nitrate 74–78, charcoal 12–15, and sulfur 10–12%. For different grades of BlkPdr, charcoals of different origins and methods of prepn are used. Powders used in shotgun shells contain charcoal from black alder carbonized in furnaces; ordinary powders use charcoal made of birch, alder, willow or linden; and Blasting

Powders use pinewood charred in kilns or furnaces

Territ (Cheddite). The name applied to a plastic blasting expl patented in 1909 by S.A.G. Nauckhoff. It was manufd since 1910 by AB Nitroglycerin in Gyttorp. Territ consists of amm perchlorate 43, Na nitrate 28, liq DNT/TNT 27.8, and collodion cotton 1.2%

Its properties are as follows: cartridge d, 1.67g/cc; vel of deton, 4700m/sec; and Trauzl test value, 340cc. Territ is comparable in properties to some low-freezing Dynamites and is safe to handle. Its brisance is such that in blasting coal or other mining operations, no small dust particulates are formed

Another formulation consists of amm perchlorate 43, AN 26 and gelatinized liq TNT (96% TNT and 4% NC) 31%. Because Territ is sometimes difficult to detonate, present formulations contain NG

Tetrazen (Tetracene). A pale-yel, fluffy, cryst solid of apparent d 0.5g/cc (Pb Azide=1.8); impact sensitivity with a 2-kg wt, 10cm (Pb Azide=6cm); and an expln temp of 140° (Pb Azide=170°)

Tetracene is used in priming compns and cover charges for initiating agents less easy to ignite. A mixt of Pb Azide and Tetracene is satisfactorily used for charges in expl rivets. It was also used together with Pb Styphnate as one of the ingredients of the so-called "Syoxydsatz or Sinoxyd" (qv) percussion compn

Tetryl. Tetryl is obtained as pale-yel crystals or as a powder of fairly uniform size. In the pure state it has a mp of 129.5°; the technical grade material melts at 128.5–129.0°

Tetryl is considered to be the most powerful expl among the aromatic nitrocompds, and is also the most sensitive. However, it can be pressed into charges without much greater risk than TNT

Because of its high sensitivity to initiation, Tetryl is used in booster charges. Its high brisance makes it an excellent expl in primers; it is also used in detonators. Because of its sensitivity to mechanical shock (40cm; TNT > 150mm), Tetryl is not used as a bursting charge in shells

Trotyl (TNT). Usually produced in flake form having a solidification pt of 80.2–80.6° for the military grade. Industrial grade TNT melts at 76–78°, and a lower grade called liq TNT or "Tri-Oil" is also manufd in Sweden

In conducting the manuf of TNT by the Bofors-Norell continuous process, a mixt of TNT isomers and DNT is sepd as an oily product. This Tri-Oil, setting pt 35–50°, is considered an excellent expl. It is used chiefly as a constituent in plastic expls of the Dynamite type, and in semi-plastic expls of the ammonia type. It is also used to some advantage for military purposes in all types of ammo which are not subjected to shock on discharge. By mixing Tri-Oil with RDX and adding a small amt of a gelatinizing agent, a powerful high expl is obtained which can be used in anti-tank mines, aircraft bombs and similar ordnance

Refs: 1) H. Fraenkel, "Handbuch für Sprengarbeiten", Atlas Diesel AB, Stockholm (1953–1963) 2) B.T. Fedoroff et al, "Swedish Explosives and Propellants", PicArsn Unpublished Manuscript (1956) 3) Anon, "Analytical Methods for Powders and Explosives", AB Bofors, Nobelkrut, Sweden (1960) 4) Anon, "Bonocord, Bofors Detonating Cord", Pamphlet, AB Bofors Nobelkrut, Sweden (1962) 5) Anon, "Chemical Products", Brochure, AB Bofors, Nobelkrut, Sweden (1962) 6) U. Langefors & B. Kihlström, "The Modern Technique of Rock Blasting", Almquist & Wiksell, Stockholm (1963) 7) R. Gustafson, "Swedish Blasting Technique", SPI, Gothenburg, Sweden (1972) 8) R. Meyer, "Explosives", Verlag Chemie, NY (1977)

Swedish Weapons in Current Service.

<u>Weapon Category</u>	<u>Type</u>	<u>Source</u>
Pistol	9mm Lahti	Husqvarna Vapenfabrik
Sub-machine gun	9mm M45	FFV Ordnance Division, Eskilstuna
Rifles	6.5mm AG42	Ljungman rifle, now in reserve units only
	7.62mm AK-4	FFV Ordnance Division, Eskilstuna
	7.62mm G3	Heckler & Koch design made under license
	6.5mm Kulspruta 58	(MAG), FN, Belgium, early manufacture
Machine guns	7.62mm Kulspruta 58	(MAG), FN, Belgium, subsequent manufacture
	Grenades, hand	M54
ATk smoke rifle, smoke	Energa	Mecar, Belgium
	M57	AB Lind Maskiner
	Grogr 1	FFV, Eskilstuna
Mortars	80mm M29	French pattern, Swedish made
	120mm M41C	Finnish/French pattern, Swedish make
	Anti-armor weapons	74mm Miniman
Anti-aircraft weapons	84mm Carl Gustaf M2	FFV, Eskilstuna
	84mm Carl Gustaf M2-550	FFV, Eskilstuna
	SS-10 ATGW	Aerospatiale, France
	Bantam ATGW	AB Bofors
	20mm cannon	AB Bofors
Armored vehicle	RB-69 SAM	(Redeye), General Dynamics, USA
	RBS-70 SAM	AB Bofors
	Pbv 302 APC	AB Hagglunds and Soner

Detailed characteristics of the above weapons can be found in the Refs

Refs: 1) I.V. Hogg & J. Weeks, "Military Small Arms of the 20th Century", Hippocrene Books, NY (1977), 51, 95, 135, 173 & 245 2) E.C. Ezell, "Small Arms of the World", 11th Ed, Stackpole Books, Harrisburg, Pa (1977), 453-58 3) D.H.R. Archer, Ed, "Jane's Infantry Weapons-1978", Franklin Watts, NY (1978)

"Sweetie" Barrel. Proplnts for small arms may be coated with a deterrent plasticizer to retard gas evolution during early travel of the projectile. This operation is performed in a rotating "sweetie" barrel, similar to equipment used for sugar-coating pills, whence the name. The barrel is equipped with a warm-water jacket to heat the charge to a temp where the coating agent will flow evenly onto the grains and be driven into the outer layers

Some proplnt grains are "glazed" or coated lightly with graphite to decrease the accumulation of static electricity during handling, and to increase the bulk d thru better packing. This

operation is also performed in a rotating barrel, which may be an unjacketed "sweetie" barrel
Refs: 1) Davis (1943), 290-91 2) Anon, EngrgDesHndbk, "Explosives Series-Solid Propellants, Part One", AMCP 706-175 (1964), 72

Swelling Coefficient. See under "Coefficient de gonflement or Pouvoir gonflant" in Vol 3, C389-R

"Swing". See under "Ballistic Pendulum Test" in Vol 1, VII & VIII

Swingfire. Brit long range command controlled wire-guided anti-tank weapon system. It was specifically designed for use by armored formations and was intended to be mounted on a vehicle. It is capable of destroying the armor on any known tank. It is, however, also suitable for infantry use

Swingfire is powered by a solid proplnt rocket. The wire-guidance is by command sig-

nals transmitted by the operator via joystick controller. Its warhead is a hollow-charge HE; length, 1.17m; body diam, 0.17m; wt, 27kg; range, 150 to 4000m

Refs: 1) M.J.H. Taylor & J.W.R. Taylor, "Missiles of the World", Charles Scribner's Sons, NY (1976), 145 2) D.H.R. Archer, Ed, "Jane's Infantry Weapons-1978", Franklin Watts, NY (1978), 621-22

SWISS EXPLOSIVES

Switzerland is a small country with an area of about 16000 square miles and a population of about 4.5 million. Since 1474, when independence was proclaimed, Switzerland has not been involved in any wars. However, this country maintains well-trained Armed Forces, and manufactures its own expls, weapons and ammo. Switzerland also manufactures several types of commercial expls of excellent quality

Production of BlkPdr and propints is a government monopoly. There is no commercial production of even sporting powders. The Swiss Gov't manufactures no military high expls except for small quantities of primary expls. Reliance is placed upon commercial manufacturers to produce whatever quantities are required by the Swiss Army. However, strict military control is exercised over the production of bulk military high expls. The commercial manufacturers must obtain both general and specific approval for the production of munitions. Normally, the Swiss Government does not permit the exportation of military high expls, since this commerce would be at variance with the Swiss neutrality policy. However, in the past, TNT in particular has been exported in order to keep certain manufg facilities in operation during periods of low Swiss ammo production

One of the most prominent expls specialists of this generation was a Swiss Professor, Dr Alfred Stettbacher of Zurich, who died in 1961. Some of the information regarding Swiss expls was obtained from Dr Stettbacher (personal correspondence with Dr B.T. Fedoroff), from the Schweizerische Sprengstoff-Fabrik AG, and from other Swiss sources

The principal expls known to have been used

or manufd in Switzerland are listed alphabetically below:

Aldofit. See Vol 1, A123-R

Amidogène. See Vol 1, A171-R

Ammonpentrit. See Vol 1, A382-L & R

Amolit. Trade name of a free-flowing bulk packaged ANFO expl distributed in Switzerland by Vereinigung Schweizerischer Sprengstoff-Fabriken; bulk d, 0.8g/cc

Bleitritroresorzinat or Bleistypnat (Lead Styphnate). See Vol 5, D1277-L ff

Cyanurtriazid (Cyanuric Triazide). Patented in 1921 by the Chemische Industrie Basel for use in Detonators. See in Vol 3, C590-R

Detonierende Zündschnur or Knallzündschnur (Detonating Fuse, Primacord). A general description of various Swiss Detonating Fuses is given in A. Stettbacher's "Scheiss- und Sprengstoffe", Leipzig (1933), 358-59 and "Spreng- und Scheisstoffe", Zurich (1948), 107 (Fulminatschnur and Pentritschnur)

The Société Suisse des Explosifs, Gamsen-Brigue [SwissP 230077 (1944) & CA 43, 2438 (1949)] patented a Detonating Fuse comprised of a core of PETN or RDX in a gel of collodion cotton and a liq expl such as NG, Nitroglycol or Tetranitroisobutylglycerin. This formulation is coated on several textile threads and covered with a fabric coating instead of Pb. The core expl is insensitive to moisture. The propagation velocity with a PETN core is reported (private communication from Dr A. Stettbacher) to be 7000m/s

Dynamit (Dynamite). The compns of Swiss Dynamites are, in general, similar to those manufd in Germany (see Vol 6, G63-L to G64-L; Vol 5, D1741-R; and Vol 3, C443-L)

Gamsit or Gelatine-Gamsit (Gelatin Dynamite). See in Vol 3, C443-L. R. Meyer, in "Explosives", Verlag Chemie, NY (1977), p 119, designates "Gamsit-Gelatine A and C" as trade names of gelatinous AN-NG expls distributed in Switzer-

land by Vereinigung Schweizerischer Sprengstoff-Fabriken, having the following properties:

Type	Density, g/cc	Pb Block Test, cc	Weight Strength, %
A	1.4	375	83
C	1.4	305	75

Meyer also states that *Telsit-Gelatine A and C* and *Aldorfit-Gelatine A and C* are identical products

Gelatine Aldorfit (Gelatin Dynamite). Same as Gelatine-Gamsit (above). See also Vol 2, B119-R and Vol 3, C443-R

Gelatine-Cheddit (Gelatin Dynamite). A plastic chlorate expl invented in 1911 by C. Rubin at Liestal, and later manufd by the Schweizerische Sprengstoff-Fabrik AG Cheddit & Dynamit. The compn is as follows: Na chlorate 79, coated with a liq mixt of castor oil 5, liq DNT 2, and TNT 14%, preheated to 40°. Some collodion cotton may also be incorporated into the mixt

The properties of this expl are: loading d 1.85g/cc (max d 1.97g/cc); vel of deton 3800 m/s; impact sensitivity with a 2-kg hammer 50cm (TNT=90cm & PA=60cm); Trauzl test value 257cc (TNT=311cc at d 1.55g/cc); vol of gases at NTP 340ℓ/kg; heat of expln at const vol (w vap) 1100cal/g or 2035kcal/ℓ; and temp developed on expln 3500°. This expl is stable and does not harden in storage

Gelatine-Penthrinitis. See Vol 6, G51-L to G52-R

Gelatine-Telsit. See Vol 6, G53-L

Hexal. See Vol 7, H77-R

Hexonit. See Vol 7, H93-R

Holtex. See in Vol 3, C396-L to C397-L and C402-R to C403-L

Matter Explosives. See in Vol 8, M45-L

Nitrogelatedynamit (Gelatin Dynamite). Dynamites of this name are those contg 20–25%

NG (or its low-freezing mixt of 4/1 with Nitroglycol) gelatinized with collodion cotton, AN and a liq aromatic nitrocompd (such as drip oil, which is a mixt of crude DNT and TNT, called "Flüssiges Tri"), serving as a phlegmatizer

Some expls of this type which belong to the class of *Sicherheitsdynamite* (safe to handle and transport) include *Aldorfit*, *Gamsit* and *Telsit*

Nitroglycerin. NG was manufd in Switzerland by the continuous methods of Schmid-Meissner and of Biazzi, which were preferred to batch processes (See Vol 3, C501-L ff)

NG for military uses was manufd by the Biazzi method at plants located in Iseleten and Wimmis, and by the Schmid-Meissner method at Gamsen. Other plants which manufd Dynamites also made NG for non-military commercial uses

Nizol. See in Vol 8, N165-L

Oxypikrinsäure (Styphnic Acid). See under "Trinitroresorzin" in this article

Pentaerythrit-tetranitrat, Nitropentaerythrit or Pentrit (PETN). The possibilities of using PETN in both military and civilian expls were realized by Dr A. Stettbacher as early as 1916. PETN was manufd at the Schweizerische Sprengstoff-Fabrik AG, Dottikon, by nitrating technically pure pentaerythritol (called penta and abbreviated as PE in Switzerland) with fuming nitric acid of d 1.52g/cc (see Vol 8, P94-L & R). The product was purified by crystallizing it from acet; its mp was 142° and cryst d 1.77g/cc

Pentostit. See in Vol 8, P131-R to P132-R

Pentritnit. See in Vol 6, G51-L to G52-R under "Penthrinitis"

Pentrit. See under "Pentaerythrit-tetranitrat" in this article

Pentro or Pentryl (Pentolite). See in Vol 8, P137-L & R

Pierrit. See in Vol 3, C443-R to C444-L

Plastit. See in Vol 8, P312-R

Plastolit. See in Vol 3, C444-L

Simplonit. See in Vol 3, C444-L

Spezialsprenggelatineo(Blasting Gelatin). See in Vol 3, C444-L

Telsit. See in Vol 6, G53-L and Vol 3, C444-L. R. Meyer, in "Explosives", Verlag Chemie, NY (1977), p 257, gives the current distributor in Switzerland as Vereinigung Schweizerischer Sprengstoff-Fabriken

Totalit. An expl compn consisting of AN 95.5 and paraffin wax (mp 54–56°) 4.5%, was developed as a military bursting charge. Its properties are reported as follows: vol of gases at NTP, 972ℓ/kg; heat of expln at const vol (w vapor), 1163cal/g; temp developed on expln, 3105°; specific pressure (force), 12021; and brisance value by Kast formula, 50x10⁶ at d 1.60g/cc (TNT=86x10⁶)

Tramex. Trade name of a powdered NG-sensitized expl distributed in Switzerland by Vereinigung Schweizerischer Sprengstoff-Fabriken. Density, 1.1g/cc; wt strength, 77%; Pb block test, 335–340cc/10g

Trinitrotoluol or Trotyl (TNT). TNT was manufd during WWII by a two-stage process, first to mononitrotoluene and then to TNT. The crude product was called *Rohtri*, mp 76–78°; and the purified TNT was called *Reintri*, mp 80–81°. There were several methods used to purify TNT, such as by Na sulfite soln or by recrystn from nitric acid. In the opinion of Dr A. Stettbacher, the best method (but more expensive) was to recryst it from hot acet contg 8% benz. This method was used at the Schweizerische Sprengstoff-Fabrik AG, Dottikon, and in Holland, for the purification of TNT used as a bursting charge in HE projectiles

The TNT used in commercial expls, such as *Aldorfit*, did not need to be of high purity, and it was sometimes advantageous to use the so-called *Flussige Tri* (liq TNT). The Dottikon *Flussige Tri* consisted of 60% TNT (called "Tri") and 40% DNT (called "Di"); its N content

was 17.24%

Straight TNT is used for cast loading various military projectiles. Pressed TNT is used as an insertion charge in Detonators in order to facilitate the initiation of cast TNT. There are also several composite expls using mixts of TNT and PETN (such as *Pentro* or *Pentryl*), and TNT and other HE's as military bursting charges

Vergé Explosivstoffe. See in Vol 3, C444-R; Vol 5, D1591 (Table 1); and Vol 6, G53-R to G54-L

Refs: 1) A. Stettbacher, "Schiess- und Sprengstoffe", Barth, Leipzig (1933) 2) *Ibid*, "Spreng- und Schiesstoffe", Rascher, Zurich (1948) 3) *Ibid*, Private communication to B.T. Fedoroff (14 Dec 1952), including a private communication from Director, Schweizerische Sprengstoff-Fabrik AG, to A. Stettbacher, Zurich (10 Dec 1953) 4) B.T. Fedoroff et al, "Swiss Explosives and Related Items", PicArms manuscript, unpublished (1954) 5) A. Stettbacher, "Sprengstoffe und ihre Wirkung in Theorie und Praxis", *Explosivst* 1954, 39–41, 113–20 & 149–53; *Ibid* 1955, 9–11, 41–45, 94–101, 118–21 & 178–82 (Explosives and their Effects in Theory and Practice) 6) Anon, "The Holtex Explosive", Hispano Suiza, Switzerland, brochure in English (1956) 7) Anon, "Oerlikon Pocket Book", Zurich-Oerlikon, Clowes & Sons, London (1958); *Proplnts & Expls*, 36 ff; HE's, 70 ff 8) Hispano Suiza SA, Deutsches Bundes Patent 1031700 (Aug 1962) ("Preparation of Brisant Explosives", Holtex) 9) R. Meyer, "Explosives", Verlag Chemie, NY (1977)

Swiss Weapons in Current Service

Detailed characteristics of the following weapons can be found in the *Refs*

Refs: 1) I.V. Hogg & J. Weeks, "Military Small Arms of the 20th Century", Hippocrene Books, NY (1977), 51, 95, 135, 174 & 245 2) E.C. Ezell, "Small Arms of the World", 11th Ed, Stackpole Books, Harrisburg, Pa (1977), 459–73 3) D.H.R. Archer, Ed, "Jane's Infantry Weapons—1978", Franklin Watts, NY (1978), 48–53, 168–73, 278–82, 351–55, 534–36, 575–80, 612–13 & 653–55

<u>Weapon Category</u>	<u>Type</u>	<u>Source</u>
Pistols	7.65mm Pistol 06/29	This Luger pistol was manufd by the Swiss Ordnance works, and is now used only by static troops
Sub-machine gun	9mm Pistol 49	Designed and produced by SIG*
	9mm Model 43/44	Almost completely withdrawn from service
Rifles	7.5mm Zf Kar 55	Sniping rifle
	7.5mm Sturmgewehr Model 1957	Used by almost all troops. Designed and produced by SIG*
Machine gun, light	7.5mm M25	Waffenfabrik, Bern
	7.5mm MG51 on bipod	Waffenfabrik, Bern
Machine gun, medium	7.5mm MG51 on tripod	As above
Grenade, hand	Model HG43	Munitionsfabrik, Thun
Grenade, rifle	Model GWG58 HEAT HE and smoke	Munitionsfabrik, Thun
Mortars	81mm Mw 33	Waffenfabrik, Bern
	81mm Mw 72	Waffenfabrik, Bern
	120mm Mw Pz 64	Waffenfabrik, Bern
	120mm Mw 74	Also mounted in an APC
Anti-tank weapons	RAK Rohr 50 83mm	Rocket launchers. Copy of the Mecar
	RAK Rohr 58 83mm	Blindicide by Waffenfabrik, Bern
	Bantam ATGW	Bofors, Sweden
	Mosquito ATGW	Contraves Italiana, SpA, Italy
Anti-aircraft weapon	20mm Type 10 La/5TG	Machine Tool Works, Oerlikon Bührle
Armored vehicle	M-113 APC	FMC, USA

*Schweizerische Industrie-Gesellschaft (SIG), Neuhausen am Rheinfall, Switzerland

SX-2. Brit-made RDX-based sheet expl
Ref: F.B. Wells, "Some Properties of the British Flexible Explosive SX-2", PATR 4782 (1975) (limited distribution)

Symon Adde Explosives. Plastic perchlorate expls freezing below -20° , patented in 1912 (BritP 13373) by Symon Adde of Grängesberg, Sweden. A typical formulation contained Amm perchlorate 40; AN 32; liq mon, di and trinitroxylenes 20; NG 5; ferrosilicon 2; and NC 1%
Ref: Colver (1938), 258-59 & 689

Sy Stability Test. An older proplnt stability test based on wt loss due to decompn. The unground proplnt was heated at 115° in an open dish for eight hrs daily for a total of six days, and the daily wt loss was detd. Limits were given for NC powders of different thicknesses.

The test was criticized on the ground that the volatile catalysts did not exert their due influence, and further, that different powders in the same oven might affect one another
Ref: Reilly (1938), 85

Sympathetic Detonation. See under "Detonation (and Explosion) by Influence or Sympathetic Detonation" in Vol 4, D395-R ff

Sytamit. Trade name of a powdered AN-Al base cap sensitive industrial expl distributed in the Ger Federal Republic by Wasagchemie. Its relatively high d allows loading even in w-filled boreholes: d 1.10g/cc; relative wt strength 82%
Ref: R. Meyer, "Explosives", Verlag Chemie, NY (1977), 256

T

T₁, T₂ and T₃. Older Fr abbrevs for technical grades of MNT, DNT and TNT (Tolite), respectively

Ref: Pascal (1930), 145–46

T4 (Trimetilitrinitroammina or Exogene). Ital abbrev for RDX. *T4 (plastico)* was an Ital Composition C-type expl mixt

Refs: 1) Anon, "Handbook of Foreign Explosives", **FSTC 381-5042**, USA For Sci & Technol Center (1965), 347–48 2) R. Meyer, "Explosives", Verlag Chemie, NY (1977), 150 & 353

T7 and T12 Propellant (US). Same as M15 and M15 Propellant (See Vol 2, C34, Table V)

Table of Distances, American. See under "Quantity-Distance Concepts" in article entitled "Safety in the Energetic Materials Field" in this Vol

TACOT. See in Vol 5, D1184-R to D1185-R under "Tetranitrodibenzo-1,3a,4,6a-Tetra-

pentolene . . ." and the following *Addnl Refs:*
 1) B.A. Stott, "Castable Heat Resistant Explosive Compositions Capable of Withstanding 500°F and Higher", **NWCTP 4461** (1967) [The expl properties of interest reported for TACOT are: Autoign pt of 350–60°; a deton vel of 6448 m/sec at 78.8% of theoretical max d and 7250 m/sec at 89% of theoretical max d; an expl power of 96% TNT; a 50% pt friction sensy of 418cm with no fires at 440cm; a 50% pt impact sensy of 66–89cm, 101cm (separate values); a mp of 410°; a therm vac stab of 0.04–0.08 ml/g/48 hrs at 120°, 0.1ml/g/hr at 260° and 0.3ml/g/hr at 280°. An expl compn is also reported consisting of TACOT/Eccosil 4712A/divinyltetramethyl disiloxane (59.4/22.8/17.8) with a d of 1.66g/cc; an autoign temp of 350°; a 50% pt impact sensy of partial burn at 250–300cm (ref is Comp B at 36 ± 3cm); and an electrostatic sensy of 10/10; no fires at 12.5 joules] 1a) C.L. Scott, "The Sensitivity of Selected Conventional and Heat Resistant Explosives at Low Temperatures", **NOLTR 70-36** (1970) [The author reports the following tabulated information from small scale gap tests run using RDX as the donor charge and TACOT-Z as the acceptor charge:

Table 1
Data Obtained Using an Acceptor Wall Thickness of 0.46 Inch

	Room Temp		Cold Temp (–65°)	
	Charge Diam, inches		Charge Diam, inches	
	0.1000	0.054	0.1000	0.054
Sample size	27	25	27	27
Log of Shock Press, kbars	1.3226	1.3317	1.3845	1.3483
Std Dev, kbar	0.0135	0.0119	0.0114	0.0378
Coeff of Variation, %	1.02	0.89	0.82	2.80
Shock Press, kbars*	21.02	21.46	24.24	22.30

Footnote to Table 1: * 50% level of shock initiating press shown

Table 2
Shock Pressure Sensitivity for 0.1000-inch Diameter Acceptor (TACOT-Z) Charge with Light Wall (0.075 inch) Confinement

	Room Temp	Low Temp (–65°)
Shock Press (25 samples, Bruceton run), kbars*	25.28	26.07

Footnote to Table 2: *50% level of shock initiating press shown]

2) P.E. Rouse, Jr, "Enthalpies of Formation and Calculated Detonation Properties of Some Thermally Stable Explosives", JChem&EngrgData **21**, No 1, 16-20 (1976) [The reported values of $-\Delta H_c^\circ$ for Z-TACOT (1,3,7,9-Tetranitrobenzotriazolo [2,1a] benzotriazole or tetranitro-1,2,5,6-tetranitrodibenzo-1,3a,4,6a-tetraza-pentane is 1375.4kcal/mole and for T-TACOT (1,3,8,10-Tetranitrobenzotriazolo [1,2a] benzotriazole) the value is 1375.0kcal/mole. The reported value of ΔH_f° for Z-TACOT is 110.5 kcal/mole and for T-TACOT 112.4kcal/mole]

3) R. Meyer, "Explosives", Verlag Chemie, NY (1977), 256 [TACOT is prepd by direct nitration of dibenzotetrazapentalene in sulfuric acid soln. It does not react with steel or nonferrous metals. The expl is of interest because of its exceptionally high stability to high temps; it remains serviceable after 10 minutes at 350°, 4 hrs at 325°, 10 hrs at 315°, 2 weeks at 280°, and 4 weeks at 275°]

TAGGING OF EXPLOSIVES

I. Introduction

Criminal use of expls in actual bombings or in bombing threats is a problem of international concern. A criminal bomb expln leaves few if any clues and if time-delayed the perpetrator can be far away from the scene of expln. Thus apprehension of this type of criminal is a most difficult and often futile task. Obviously, law enforcement agencies, and indeed society at large, would welcome viable means of reducing criminal bombings

In the US, the Bureau of Alcohol, Tobacco and Firearms (BATF) and other Federal agencies have been seriously concerned over the past few years with the development of methods to control the illegal use of expls. Ideally, the problem of control would be greatly simplified if every ounce of expl, legally manufd and legally used, could be completely accounted for. Unfortunately, such complete accounting is impossible because of pilferage, subterfuge, etc. Furthermore, expls can be and are being prepared illegally in clandestine expl "plants".* Thus, in spite of all efforts by BATF and other agencies, expls do get into the hands of criminals and are used in actual bombings or in bombing threats. Clearly, additional procedures are needed to supplement the strictest possible control of expl manuf, distribution, storage and use

A supplementary program that could help to control criminal bombings is that of *explosive tagging*. This is a two-part program which consists of: 1) developing a *taggant* that survives detonation and can be coded to provide information as to the source of the expl and its last legal possessor (*identification tagging*); and 2) developing a *taggant* that makes the expl easy to detect (*detection tagging*)

Identification tagging could furnish valuable leads in apprehending the perpetrators by providing law enforcement agencies with:

- Justification for initiating an investigation
- A "starting point" for the investigation
- Important evidence for the judicial pro-

*The current proportion of "home-made" expls in criminal use is fairly small and the attrition rate of clandestine expl "plants" is expected to be rather high. However, in incidents involving malicious mischief by juveniles, home-made expls are frequently used

ceedings against apprehended suspects
For example, the recovery of taggants which establish that Dynamite was used in an expln of a manufg facility that used potentially expl gases (but never used Dynamite) clearly demonstrates that the expln was deliberate (criminal) and not accidental. The recovered taggant might also enable investigators to determine the last legal possessors of the Dynamite and thus provide a good starting point for the investigation. Furthermore, the recovered taggants may be valuable in the judicial proceedings after a suspect has been apprehended for establishing that a crime was committed and for associating the suspect with the crime (for example, finding in the suspect's possession Dynamite of the same manuf date and lot as that used in the bombing). Even though no suspect is apprehended, identification tagging can still be beneficial in that it can point to the source of the expls used in criminal acts. Law enforcement agencies can then ensure that this expl source is eliminated, and if necessary initiate criminal proceedings against the legal expl distributor or user who was the source of the expls

Identification tagging has another important application. Underground coal mines are required by law to employ only certain types of expls, called permissibles (see Vol 8, P182-R), in their mining operations. Periodic governmental inspections are made to ensure compliance with this law. Under normal circumstances inspectors have no difficulty in determining whether permissible expls are indeed being used. However, after an accidental fire-damp or coal dust expln there is usually only circumstantial evidence as to the type of expl that was involved. Recovery of taggants after such an accident can be most helpful in establishing the cause of the accident and in assigning liability for the accident

Detection tagging appears to have more limited applicability than identification tagging. Its prime benefits are anticipated to be in the reduction of infrequent but potentially very costly bombings, such as bombings of aircraft and airports or of government offices and facilities whose disruption could have grave consequences to national well-being and security. Under appropriate circumstances detection tagging can also be useful in distinguishing between real bombs and hoaxes, and in helping to locate bombs after a communicated bombing threat

To place tagging in its proper perspective requires an assessment of the existing criminal bombing threat. A profile of this threat will be presented in Part II of this article. Potential identification and detection tagging schemes will be described in Parts III and IV, respectively. Part V will deal with the difficult and controversial problem of gaging the effectiveness of tagging programs. Costs of tagging expls will be discussed in Part VI

Although criminal bombings are an international problem, this article is limited to consideration of the bombing threat in the USA and the use of tagged expls to control it

II. Profile of the Bombing Threat

The development and implementation of an effective program of tagging expls requires an assessment of the extent and magnitude of the current and projected bombing threats. For example, it is important to obtain the best possible data on bombing frequency, targets attacked, expls used, etc. These data should then form the basis for projecting future bombing trends

a) Data Source & Data Reliability

Bombing data can be acquired in two forms: documented bombing statistics and information obtained via personal contact (visits or telephone conversations) with knowledgeable personnel in government and in the private sector. The main sources of documented data are the BATF, FBI, NBDC (National Bomb Data Center) and the California Department of Justice. Most of the fruitful personal contacts are expected to be with local police department "bomb squads" and BATF bomb-scene investigators

Whenever possible, comparisons should be made between different data sources to evaluate the degree of reliability of the acquired bombing statistics. Unfortunately, such comparisons show that disagreement among data sources is about as frequent as agreement. Furthermore, no unprejudiced criteria are found for determining which data source is the most reliable. However, from the point of view of projection of data into the future, the source that contains data over many years is to be preferred to that with only a few years' data. It is significant that a preliminary audit in California revealed that only

Table 1
Minimum Bombing Incidents Statistics Summary^a

Item	BATF		FBI	
	1977	1978	1977	1978
Explosive bombings, number	1,037 ^{-b}	896 ^{-b}	867	768
Undetonated explosive bombs, number	319	287	118	105
Incendiary bombings, number	339	446	248	349
Unignited incendiary bombs, number	81	71	85	79
Criminal accidents, number ^{-c}	21	67	—	—
Property damage from bombings, millions of dollars ^{-c,d} . . .	\$ 10	\$ 17	\$ 9	\$ 9
Injuries ^{-c}	180	185	162	135
People killed by bombings ^{-c}	38	23	22	18

a- BATF reported 3,177 total incidents in 1977 and 3,256 in 1978. Total incidents include accidents, threats, seized and recovered explosives, and hoaxes as well as actual explosive and incendiary bombings. The OTA study was concerned only with explosive bombings

b- Of these 953 in 1977 and 787 in 1978 were against substantial targets

c- Includes both explosive and incendiary bombings. OTA was unable to obtain separate figures for number of criminal accidents, injuries, deaths, and property damage caused by explosive and incendiary bombs.

Incendiary bombs and bombings would not be affected by the proposed taggant program

d- Actual value probably considerably higher due to lack of data file updates

Source: BATF 1978 Explosives Incidents Report, FBI Uniform Crime Report: Bomb Report, 1978

about two-thirds of the California bombings contained in the records of local law enforcement agencies were reported to the state agency responsible for maintaining bombing statistics. Since California has a mandatory requirement for reporting bombings, the fraction of bombings reported thruout the entire United States may be even lower than two-thirds

An example of the variance in the reported bombing statistics is shown in Table 1, taken from Ref 12

b) Projected Bombing Trends

The writer and his associates (Ref 2) performed a statistical analysis of bombing trends and concluded that the best prediction of future trends is that bombing frequency, number of victims and property damage will stay at about the level given by the average number of these categories for the years 1972-1976. As shown in Table 2, this prediction is supported by the data collected in the two years after the prediction was made. Note, however, that various law enforcement agencies as well as forensic psychologists (Cassandra-like) predict a substantial increase in future criminal bombings

c) Targets Attacked

A large proportion of all clandestine explns is attributable to pranks, vandalism and experimentation by juveniles. These explns generally do little damage and have few victims (except that the perpetrators themselves are the occasional victims). The trends in attack on various targets are shown in Table 3. This Table is taken from Ref 12 and includes bombings by incendiary as well as expl devices. Note that residences, commercial establishments and vehicles constitute a large proportion of the "substantial" targets bombed. Most likely the majority of "vandalism" targets are not shown in this table because they were not reported or investigated

d) Explosives Used

A detonated expl device leaves few clues as to the expl that it contained. Nevertheless, diligent lab examinations of bombing debris can uncover useful information about the expls used in criminal bombings. This can be supplemented by information obtained from devices that were recovered before they expld (usually called "attempted bombings" in bombing statistics)

Table 4, from Ref 2, shows a comparison of

Table 2
Comparison of Predicted and Observed Bombing Trends

	Predicted*	1972	1973	1974	1975	1976	1977	1978	Source of Observed Data
Number of Bombings	922± 244	714	742	893	1088	852 854	867 1037	768 896	FBI BATF
Number of Bombing Attempts	196 ^{-a}	237	253	236	238	188 318 ^{-b}	118 319 ^{-b}	105 287 ^{-b}	FBI BATF
Number of Injuries	222± 82	176	187	207	326	212 159	162 180	135 185	FBI BATF
Number of Fatalities	37± 15	25	22	24	69	50 44	22 38	18 23	FBI BATF
Property Damage ^{-c} Millions of Dollars (1976 Dollars)	15.4± 8.8	8.0	7.3	9.9	27.0	11.3	8.9 10	9.2 17	FBI BATF

*. ± values are 90% Confidence Levels

a- Confidence Level not calcd

b- Includes undercover buys

c- Includes incendiary incidents

Table 3
Bombings by Specific Targets for 1977-78 (actual detonations or ignitions)

Type target	Total Incidents		No. Killed		No. Injured		Property Damage ^a	
	1977	1978	1977	1978	1977	1978	1977	1978
Residential	352	294	17	7	66	57	\$ 1,022.3	\$ 2,982.2
Commercial	367	375	7	6	48	46	6,640.1	8,777.7
Airports/aircraft	7	5	1	—	1	—	.2	.2
Police facilities/vehicle . .	14	29	—	—	—	—	5.8	70.4
Educational	106	97	—	—	13	5	43.1	532.3
Government (local)	24	9	—	1	1	4	145.6	70.1
Government (federal) . .	26	22	—	—	4	1	2.4	6.6
Military Installations . . .	4	3	—	—	—	1	—	0.0
Utilities	51	57	1	—	1	2	628.0	1,727.7
Banks	22	18	—	—	—	—	225.2	49.3
Vehicles	216	252	11	7	24	25	363.3	2,119.4
Open areas	36	40	1	2	8	13	.5	4.2
Mailboxes	48	69	—	—	1	2	25.8	2.1
Other	90	137	—	—	8	27	1,206.8	869.9
Unknown ^b	34	2	—	—	5	2	22.6	0.0
	1,397	1,409	38	23	180	185	\$10,331.7	\$17,212.1

a- Property damage figures are in thousands and are estimated

b- This category includes those incidents where the type target was either unknown or not reported

Table 4
Explosive Fillers Used in Criminal Bombings
Comparison of Lab Analyses and Bombing Attempts (Normalized [§] BATF Data)

Explosive	1977 *		1976		1975	
	Lab	Bombing Attempts	Lab	Bombing Attempts	Lab	Bombing Attempts
Dynamite ^a	32.7	32.6	33.1	41.5	46.4	48.9
Black Powder	12.9	29.8	13.2	17.4	11.1	10.9
Smokeless Powder	19.2	17.3	24.5	21.2	18.9	26.1
Military	2.5	5.8	4.0	8.2	4.6	5.4
Primers ^b	1.7	1.0	0.0	2.0	1.3	6.5
Others ^c	31.0	13.5	25.2	9.7	17.7	2.2
	100.0%	100.0%	100.0%	100.0%	100.0%	100.0%
Number of Samples	398	204†	244	410†	279	177†

Footnotes to Table 4:

[§] Each explosive percentage is divided by $\frac{100 - \% \text{ unknowns}}{100}$

* One-half year data

† It is possible that a few of these were analyzed in BATF laboratories

a- Includes slurries and nitrostarch dynamites

b- Includes boosters and detonating cord

c- Includes flash powder and other low explosives, blasting agents and home-made explosives

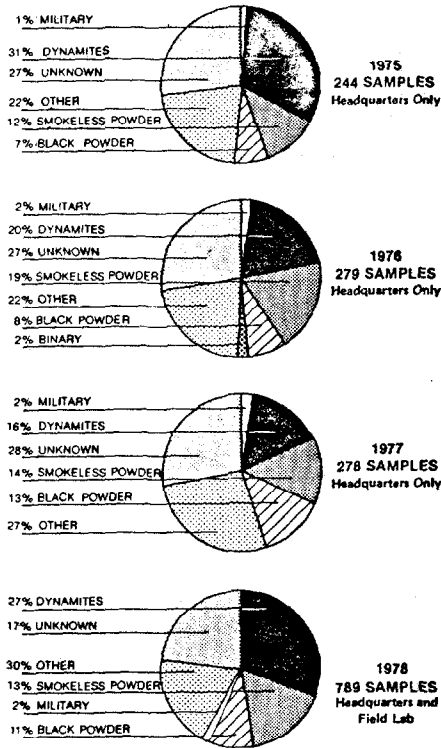

Fig 1 Explosives Used in Criminal Bombings (BATF data quoted in Ref 12)

expls analyzed in bombing debris ("Lab") and those contained in recovered devices. Agreement is quite good except in the "others" category. What Table 4 does not show is the large "unknown" category contained in the lab data. This is better brought out in Fig 1, taken from Ref 12

Note that the unknown category is appreciably smaller in 1978 than in previous years. The use of *Dynamites* is fluctuating, but on the average it is around 1/3 of the expls used. The use of both *smokeless* and *black* powders has increased slightly in recent years, but the former appears to have levelled off at about 15% and the latter at about 12%. The catch-all "other" category is currently at about 30%

e) *The Bombing Profile*

Based on data available thru early 1977, the writer and his associates (Ref 2) reached the following conclusions:

The expl fillers used in criminal bombings have the following approximate distribution:

- Dynamites 25%
- Military Explosives 2%
- Smokeless Powder 15%
- Black Powder 8%
- "Other" (mostly improvised) 18%
- Unknown 32%

Although Dynamite is the expl used in only one-quarter of all bombings, its use accounts (on an unknown-free basis) * for at least 55% of bombing injuries, at least 65% of bombing fatalities, and about 80% of bombing damage (see Fig 2)

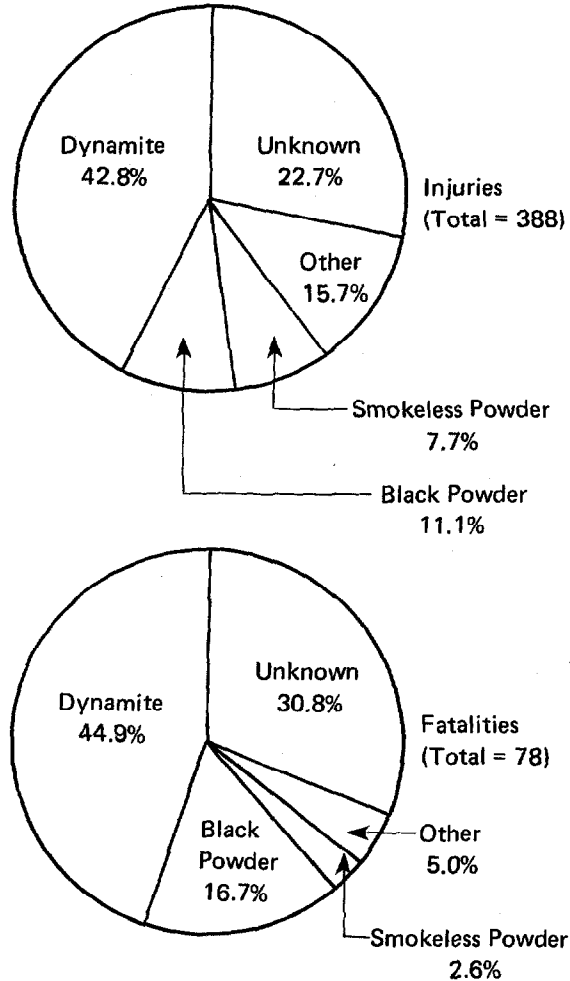

Fig 2 Bombing Casualties as a Function of Explosives Used (BATF Data)

* Normalizing the known expls

The use of pipe bombs in criminal bombings has increased from about 28% (of all bombs) in 1975 to about 37% in 1977

Positively identified frequency of use of fuse blasting caps (non-electric) exceeds the frequency of use of electric blasting caps. A large undetermined category, however, makes this conclusion uncertain. The use of a blasting cap (electric or non-electric) could be established for only three-quarters of all cap-sensitive expls. Thus, in about one-quarter of the bombings involving the use of cap-sensitive expls, the data made no mention of blasting caps. It is to be expected that in catastrophic bombings (the catastrophic bombing of LaGuardia Airport, for example) electric blasting caps are used

The most frequent targets of criminal bombers are residences, commercial facilities and vehicles. Together these account for over one-half of all the targets

As expected, attacks on crowded facilities such as airports result in a higher proportion of casualties than attacks on such people-free targets as idle construction equipment. It is significant, though again not unexpected, that there is a relatively high proportion of fatalities in attacks on vehicles

BlkPdr is the expl most frequently used in bombings of schools, and to a lesser extent, residences. The expl most frequently used in attacking most other targets is Dynamite

Accurate information on bombing motives is lacking, but roughly two-thirds of all bombing may be attributable to malicious destruction and personal animosity

A recently completed study by OTA (Ref 12) is in substantial agreement with the above conclusions

III. Identification Tagging

The basic purpose of identification tagging of expls is to provide information on what expl was used, who manufd it, and under ideal circumstances, the last legal purchaser of the expl. One can distinguish three categories of *identification taggants*: 1) material that will not survive detonation but can provide the above information if an undetonated criminal device is recovered; 2) radioactive material; and 3) material that will survive detonation

1) *Taggants That Do Not Survive Detonation*

The *date-shift code* is not a method of tagging in the truest sense. However, since it is required by law in the USA it will be described briefly. Incidentally, from now on, we shall make frequent reference to the following Federal agencies: **BATF**, Bureau of Alcohol, Tobacco and Firearms, Treasury Department; **FBI**, Federal Bureau of Investigation, Justice Department; and **OTA**, Office of Technology Assessment, US Congress

Since 1970, the date, shift, manufacturer and product name have been printed in code on the cartridge of cap-sensitive high expls. The manufacturer keeps records, by that day-shift code, and can tell to whom each batch of material was sold. Distributors also are required to keep records of sale. It is thus possible, from the date-shift code, to compile a list of last legal purchasers of expls from a lot with the same date-shift code. **BATF** maintains a National Explosives Tracing Center, whose function is to coordinate this activity. A typical trace would start with the recovery of an undetonated bomb. This code would be telephoned to the tracing center which would forward the information to the manufacturer, who would provide a list of consumers or distributors. If expls from that lot were sold to a distributor or distributors, they would be contacted for a list of retail purchasers

The date-shift code information can be useful in investigations of criminal bombings, although at best its utility is limited to instances where the expl is recovered before detonation, or in some cases, where a low-order detonation does not destroy the cartridge. In addition, the information is only on cap-sensitive high expls, and on the *packages* of detonators, BlkPdr and detonating cord. No trace data is available for other expl material, such as smokeless powder, individual detonators, and, of course, on cap-sensitive expls that have been removed from the cartridge. It is known that some bombers purposely remove the data-shift codes from Dynamite cartridges

The British apparently use a method somewhat better than the date-shift code in that their identifying code consists of colored threads within the expls. These threads do not survive the detonation, but the information content is not lost by discarding the cartridge, as can be done with the date-shift code

2) *Radioactive Taggants*

Addition of small amounts of radioactive isotopes to expls during the manufg process appears to be particularly attractive at first glance, as it provides a mechanism for both identification of the expl materials from the postdetonation debris, and a simple detection mechanism. There are a large number of radioisotopes, so an identification scheme could certainly be developed that would provide sufficient unique code species, although there would be some limitations of availability and cost. There is sufficient information to indicate that small-to-moderate doses of radioactivity do not affect expls (Ref 1). The problems with using *radioactive taggants* are those of potential health hazards and the phobia of the general public to anything radioactive. It is well known that exposure to radioactivity is deleterious to health, but the health hazards of low-level exposure to radiation are not well-defined. The current trend is toward severe limitation of exposure. Thousands of people come into direct contact with expls every day at the manufacturers, distributors, and users levels; therefore, a large number of people would have some exposure. Primary concern would be at the manufg level, where workers would have more continuous exposure than a user. However, miners in an underground mine could be subjected to considerable and prolonged dosages because of accumulation of radioactive materials and inadequate ventilation. Aside from the adverse psychological effect the use of tracers might have on such workers, and the possible long-term effects of low-level exposure, there could be a large cost impact due to the need for specially trained personnel, as well as storage, handling and decontaminating equipment. If it were necessary for the Nuclear Regulatory Commission to control the shipment of the expls, and to license and otherwise supervise all expl users, additional major costs and inconvenience would occur.

A final drawback is that interpretation of the information encoded in the postdetonation debris might be a fairly complicated lab procedure that involves sample prepn, radiation counting and radioisotope identification. Only a limited number of labs in the country have the trained personnel and facilities for these analyses.

Police forensic labs are not among them

3) *Taggants That Survive Detonation*

In view of the discussion in 1) and 2) above, it is clear that non-radioactive taggants that can survive detonation are the best hope for a viable identification tagging system. Several such taggants have been investigated. These have been effectively described in an OTA report (Ref 12) and much of the following description is taken from that report

a) *3M Color-Coded Taggant*

More research has been conducted with the 3M (Minnesota Mining and Manufacturing Corp) identification taggants than with any other. This taggant consists of an irregular chip of thermosetting melamine alkyd resins approximately 0.12mm thick and about 0.40mm in its greatest dimension. An eight-layer construction with variation of the sequence of colors provides the necessary library of codes. This is illustrated in Fig 3, taken from Ref 3. A total of approx 6 million unique codes is available, when allowances are made for certain forbidden adjacent colors that are too difficult to distinguish. One face of the taggant visibly fluoresces when illuminated with ultra-violet light (366 nanometers) as an aid to recovery. The other face contains iron powder, allowing the taggant to be picked up by a magnet

In theory, the taggant can be recovered from the debris by use of a magnet and a uv light, read in the field by a low-power microscope, and traced thru the BATF tracing center. In practice, lab separation may be needed in most bombings. Recovery from debris and subsequent lab procedures are relatively simple, however, and can be performed in field labs with little equipment and unsophisticated personnel

Several variations of the basic concept have been tried some including a polyethylene encapsulant and some including slightly different chemical and physical properties of the individual layers. The safety, survivability, utility, and cost aspects of these taggants will be discussed later

b) *Westinghouse Ceramic Taggant*

The Westinghouse taggant consists of a mixt of rare-earth compds, bound together into a ceramic-like particle, whose appearance is similar to a grain of sand, and whose largest dimension is approximately 0.2mm. Each of the rare-earth

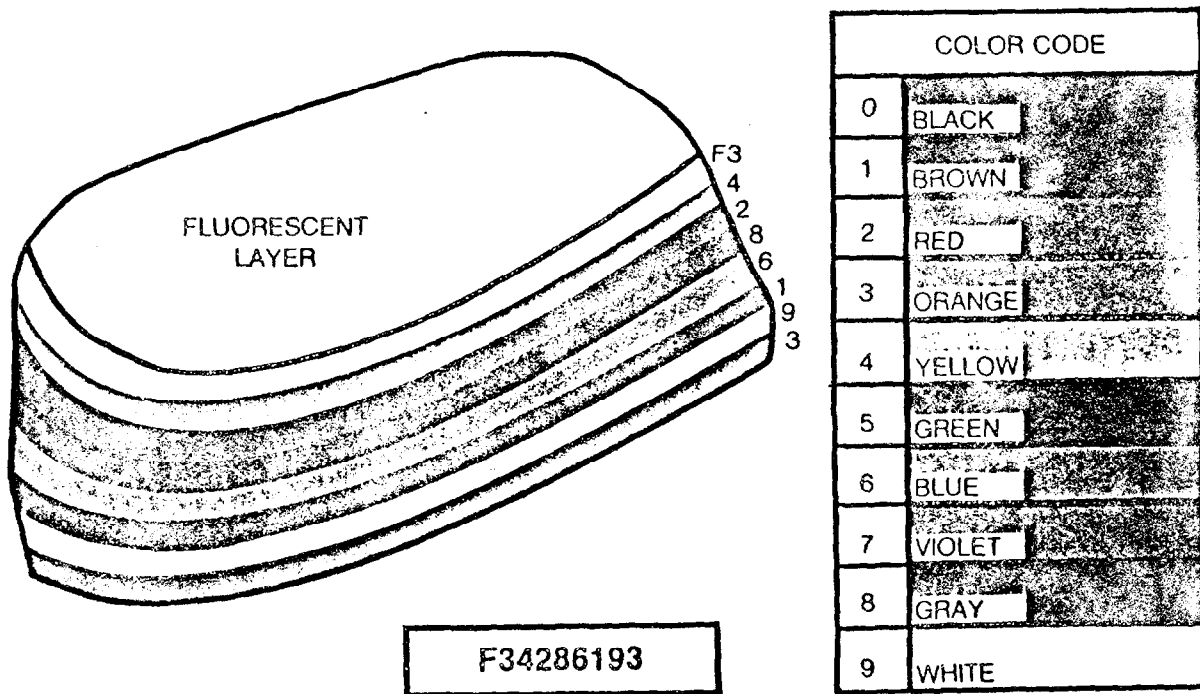

Fig 3 The 3M Company Color-Coded Taggant

compds fluoresces at a characteristic wavelength when illuminated by uv radiation (325 nanometers). A scanning monochromometer can be used to read the radiated wavelength of the various rare-earth compds, and thus identify the taggant code. The 10 rare earths that have been evaluated, and their characteristic emission wavelengths are:

	Nanometers
Strontium chlorophosphate: europium	447
Yttrium vanadate: thulium	476
Yttrium phosphate: cerium, terbium	546
Yttrium vanadate: erbium	555
Yttrium vanadate: dysprosium	575
Yttrium vanadate: samarium	608-648
Yttrium vanadate: europium	618
Yttrium oxysulfide: europium	626
Strontium fluoroborate: europium, samarium	687
Strontium fluoroborate: europium	375

As in the 3M taggant, the Westinghouse taggant contains a spotting phosphor which fluoresces in the visible when illuminated by short-wave ultra-violet radiation (254 nanometers), and magnetic particles to aid recovery

Due to the limited number of rare-earth compds available, and the fact that the individual components are not segmented like the 3M taggant layers, the library of possible codes is only approx 3,000 even with three distinct spotting phosphors. However, use of *different concns or pairing* of two different taggants to form a unique species can significantly increase the library, with approx 600,000 codes available for the paired taggant variation

c) Curie Point Taggant

The Curie point taggant consists of a collection of five distinct ferrites, primarily metal oxides, packaged with an ultra-violet sensitive spotting phosphor in a binder of K silicate. Ferrites lose their ferromagnetism when the temp of the ferrite is raised above a specific temp, called the Curie point temp. Identification of a particular taggant is thus accomplished by placing the recovered taggant in a temp-controlled chamber and recording its magnetism as a function of temp

Approx 50 ferrites are available with Curie points in a practical temp range. The 50 ferrites, used in combinations of 5 at a time, yield a

library of approx 2 million unique entities (Ref 4)

Taggant Survivability

This very important aspect of identification tagging is a subject of considerable controversy. Most of the tests on taggant survivability were done with 3M taggants. BATF and its contractor, Aerospace Corp, claim that survivability of these taggants is quite adequate for many expls under a variety of conditions. Expl manufacturers such as IME (Institute of Makers of Explosives) and other associations, however, claim that 3M taggant survivability is poor under most circumstances. OTA, from a limited number of tests, concluded that some taggants do survive but may be very difficult to recover under field conditions (Ref 12). In OTA sponsored tests, lab analysis of bombing debris did lead to correct identification of the expls used. However, field analysis not only failed to identify the expls, but in most tests field investigators were unable to determine whether they had actually recovered any taggants. Sufficient taggants were found only after lab assay of the bombing debris

The Aerospace survivability tests, under more or less controlled conditions (Refs 4 & 5) provided the following general findings:

- 3M taggants have poor survivability in detonation of expls of high detonation pressure, eg, boosters
- Detonation of large quantities of tagged expls tends to reduce the number of surviving taggants

Incidentally, both Aerospace and OTA relate poor survivability to "high-energy" expl. This is basically incorrect. The data shown that TNT and other military *high-pressure* expls (used in commercial boosters) destroy more taggants than *equally energetic* but *lower detonation pressure* commercial Dynamites

OTA's assessment (Ref 12) of 3M taggant survivability is as follows:

"The identification taggants developed by 3M appear to survive the detonation of commercial explosives under ideal conditions. Confinement and fire may adversely affect survival, although test data is very limited. Recovery of the taggants appears to be a function of the specific incident conditions (weather, type of target, firefighting activities) as well as the training and

care of the field and laboratory investigators. A trained team can probably recover debris from which a laboratory can separate taggants under most incident conditions"

The other two taggant systems (Westinghouse and ferrites) are expected to survive detonation better than 3M taggants. Preliminary tests have confirmed this expectation (Refs 4 & 5). The ceramic nature of both the Westinghouse and ferrite taggants should make them resistant to thermal degradation. Since the rare-earth doping in the Westinghouse taggant is homogeneous thruout the material, the full code can be read from even a small recovered taggant chip

At present, legal problems have stopped further investigation of the Westinghouse taggants (Refs 3 & 12)

Compatibility

Before any additive can be safely incorporated in an expl, it is mandatory to determine whether the additive can react chemically with the expl even under rather extreme conditions, and whether the additive can physically increase the sensitivity of the expl, eg, its sensitivity to impact or friction

It is well known that grit-like particles increase the sensitivity of expls to impact and friction (Ref 1 & Encycl, Vol 7, I35-R to I55-R). Both the Westinghouse and ferrite taggants are "grit-like" and tests have shown that they do sensitize expls to impact (Ref 6). Consequently both these materials would require encapsulation in a "soft" matrix such as polyethylene. Any such encapsulation must be thorough (every taggant particle must be encapsulated) and be capable of surviving any pre-detonation wear-and-tear. Furthermore it appears that encapsulant weight must be substantially greater than the taggant weight (Ref 6)

Generally speaking, the 3M taggants do not sensitize expls to impact or friction even with unencapsulated melamine-alkyd cores. With a more highly cross-linked and consequently harder core there was evidence of sensitization. As an added safeguard, it is desirable to encapsulate even the "soft" taggants in polyethylene

A more difficult and as yet unresolved question is that of chemical compatibility of expls and taggants. Preliminary results (Ref 6), when interpreted somewhat optimistically, suggested that there was no problem. More recently,

however, quite pronounced instability has been observed with a double-base smokeless powder and 3M taggants, as well as Comp B (booster charge) and 3M taggants (Ref 12). These occurred under severe test conditions, namely 1:1 expl/taggant wt ratios (or 50- to 100-fold greater than the "normal" homogeneously distributed taggant concn) and high temps. Nevertheless, these findings are a cause for concern

Clump formation and uneven mixing can result in *local* abnormally high taggant concns. Reactions that occur in a few hours at elevated temps may also occur in days, months or even years at much lower temps. Since the lifetime of most commercial expls is of the order of a few years, such slow reactions can be a potential hazard. Thus, it is imperative to establish the cause of the observed instability, characterize the conditions under which this instability occurs and determine whether it can occur with different expl/taggant combinations

Westinghouse taggants exhibited no reactivity with expls in a limited number of tests. In an even smaller number of tests, ferrite taggants did show evidence of slight reactivity (Ref 6)

Performance

Inclusion of taggants may affect expl and/or proplnt performance. Based on analysis and limited tests it does not appear that taggants degrade the performance of commercial expls (Refs 6 & 12). More tests, particularly on aged taggant-containing expls are necessary. Preliminary tests suggest that abnormally high concns of taggants decrease the ballistic performance of smokeless powders (Ref 12). More tests are needed, again with emphasis on gaging long-term effects

There is a special problem with *Permissible Explosives* (expls that are certified for use in gassy mines). By law, every modification of a permissible formulation has to pass certain prescribed tests at the US Bureau of Mines. Inclusion of taggants in Permissible Explosives would therefore entail very extensive testing

On the supposition (not necessarily correct) that every bomb contains a detonator, and that most detonators are electric blasting caps (also incorrect, at least in the US), the Materials Research Laboratories of Australia investigated the inclusion of metal strips, bands or pellets as identification tags for electric blasting caps (Ref

7). Experience as well as actual tests showed that the closure plugs of electric blasting caps often survive detonation. Consequently, they are an attractive region for emplacement of metal coding strips or pellets which can also survive detonation. Preliminary tests indicate that roughly half of the coding material was recovered. In its limited applicability this is an attractive method since it overcomes most problems of survival, compatibility and degradation of performance

IV. Detection Tagging

Naturally it is most desirable to detect a criminal bomb before it explds. To do this for all bombs is an impossible task since it is utterly absurd to imagine that a detection sensor will be operating at every location where a bomb might be placed. Thus, any scheme of detection tagging and sensing will be very much more limited in scope than identification tagging. Detection tagging can, however, become a most valuable weapon against criminal bombings of targets whose destruction has the potential of catastrophic loss in life or property, or targets of vital importance to national well-being. It would be particularly valuable for the protection of targets that have limited access to the public. Examples of this are boarding and baggage handling areas of airports, US Senate chambers, nuclear facilities, etc. Bombing of such targets could have catastrophic consequences, eg, a single large airplane bombed out of the sky could result in greater life and property loss than all the bombings in the US over the last decade

It should be emphasized that the state of development of viable expl detection schemes is much less advanced than that of identification tagging. Very many serious problems are still unresolved. Consequently, any estimates of the efficacy and applicability of detection tagging are even more *oracular* in nature than those for identification tagging

The BATF-Aerospace detection tagging program emphasizes two approaches: development of suitable taggants and development of viable detection sensors. The achievements of these two approaches are summarized below

Development of Detection Taggants

One can envision three basic types of de-

tection taggants: *radioisotopes* (naturally occurring or specifically generated), *electromagnetic taggants*, and *vapor taggants*

Use of natural radioisotopes for detection taggants possesses the same drawbacks as they do for use as identification taggants; the above discussion need not be repeated here

Induced radioactivity by bombardment of appropriate additives with high energy particles is in most cases impractical, costly and potentially harmful to personnel. Its use may conceivably be justifiably for very limited applications. In addition, extensive efforts would be required to demonstrate that such bombardment would have no deleterious effects on innocuous materials (eg, contents of a suitcase) in which expls may be hidden

According to OTA (Ref 12):

"A number of other activation taggant techniques have been suggested, including the doping of explosives with material that would enhance the effectiveness of X-ray or similar devices. These concepts all lack specificity, however, and could cause the X-ray to be triggered by many common items, resulting in an unacceptable failure rate"

Potential use of *electromagnetic taggants* has also been reviewed by OTA (Ref 12):

"Electromagnetic taggants incorporated into a detonator, such as the passive harmonic radar taggant investigated by the Aerospace Corp, offer the possibility of detection at a distance with a relatively low rate of false alarms. All of the concepts so far proposed, however, can be easily defeated by wrapping explosives in metal foil. In addition, inclusion of such devices would probably have a significant effect on the procedures used to manufacture detonators, on detonator cost, and significant false alarms could be caused by common diodes from radios, calculators, and other electronic instruments"

"A variation of the idea of electromagnetic taggants has been proposed, called detonator deactivation. In this concept, a reed switch is connected in series with a detonator bridge wire. Illumination of the detonator by a switchable electromagnetic source would cause the reed to open. A number of methods are possible to ensure that the reed could not be subsequently closed. The advantages of the concept are twofold:

- the necessary illuminator could probably be made quite inexpensively, allowing it to be used to protect far more targets than would be possible with other detector concepts, and
- the deactivator process is passive — no operator is necessary"

"Disadvantages include the fact that deactivation rather than detection of bombs would offer no help in finding the would-be criminal bombers; significant (and possibly costly) impacts on current processes of manufacturing detonators; and the risk of *accidentally deactivating* detonators, resulting in their failure for normal use. No research beyond initial conceptualization has been conducted for this concept"

It is the writer's opinion that accidental deactivation of commercial detonators and consequent "misfires" in legitimate mining and construction blasts has the potential of claiming more victims and entailing higher cost than all of the current criminal bombings

The bulk of research on expl detection has been with *vapor taggants*. This research is well summarized in the OTA report (Ref 12), from which we quote the following:

"Vapor taggants share the common taggant requirements of stability, inertness, compatibility with explosives, and absence from normal materials. In addition, they must have a vapor pressure sufficient to produce enough molecules to be sensed, but not so high that a large initial mass would be required to ensure continued operation when placed in explosives that have a shelf-life of several years. They must have a relatively steady molecule emission rate over a 5- to 10-year shelf-life, must not produce an environmental hazard, and must not readily adhere to surfaces with which they are likely to come into contact"

"Several hundred different vapor sources have been considered, with almost 200 having been investigated in the laboratory. Avenues of approach have included the use of disproportionating salts, the direct adsorption of vapor taggants into the elastomeric plug material of detonators, and the microencapsulation of taggant materials"

DISPROPORTIONATING SALTS

"A number of salts of weak acids and bases, such as boron trifluoride adduct compounds, dis-

proportionate or separate into two or more constituent parts, some of which sublime at room temperatures, theoretically providing a possible stable vapor emission source. Tests conducted by the Aerospace Corp indicated that no compounds investigated had the proper balance of vapor pressure, emission rate, desired lifetime, and projected detection limit by a sensor to allow the use of a sufficiently small amount of taggant material. It is possible to control the emission rate of a high vapor pressure salt by the use of a microencapsulation membrane; use of such a membrane allows the consideration of a large number of more easily handled liquid taggants, however, as described below”

ELASTOMERIC ADSORPTION OF VAPOR TAGGANTS

“The adsorption of the vapor detection material directly into the elastomer used to fabricate the end plug of detonators offers a number of advantages, including removal of the necessity for additional steps or changes in the detonator fabrication process. Research has therefore been conducted to evaluate the effectiveness of various elastomer/taggant pairs. Taggants evaluated include sulfur hexafluoride, and holo-genated alkanes, amines, aromatics, esters, and ketones. A number of combinations appear feasible, although useful lifetimes may be shorter than the 5-year minimum desirable. A more severe limitation, however, is that the elastomerically adsorbed taggants would be useful only on detonators, and possibly with detonating cord. None of these taggants appears to be as successful as

other candidates when microencapsulated for use with other explosive materials. Use of separate taggants for detonators for other explosives would lead to the development of two sensors or to the requirement for dual-mode sensing in a single sensor, an unnecessary sensor development constraint”

MICROENCAPSULATED VAPOR TAGGANTS

“Approximately 180 vapor materials have been screened in the laboratory as candidate microencapsulated vapor taggants. In addition, several hundred other materials were rejected after a thorough analytical review. Five candidate perfluorinated cycloalkane compounds have been extensively tested, and have successfully completed barrier penetration, mutagen, toxicity, and atmospheric impact testing. The five candidate vapor taggants and their chemical properties are shown in table 16”

“A parallel research effort has been underway to find an appropriate microcapsule material. The optimum material would be inexpensive, easy to use with the candidate taggant materials, compatible with the explosive materials, and form membranes that account for only 10 to 20 percent of the microencapsulated taggant weight”

“Emission rate studies are currently underway with a number of membrane materials. Early tests were very encouraging; a number of more recent test results show variations in emission rate from lot to lot and as a function of ambient relative humidity and temperature. Tests have not yet started on long-term emission behavior,

Table 16 (from Ref 12)
Candidate Vapor Taggant Properties

Chemical name	Abbreviation	Empirical formula	Molecular weight	Boiling Point °C	Melting Point °C	Specific gravity	Vapor pressure (300°K=27°C)
Perfluoro-1,2-dimethyl-cyclobutane	PDCB	C ₆ F ₁₂	300	45	-32	1.67	390
Perfluoromethylcyclohexane	PMCH	C ₇ F ₁₄	350	76	-37	1.79	106
Perfluoro-1,3-dimethylcyclohexane	PDCH	C ₈ F ₁₆	400	101-2	-70	1.85	35
Perfluorodecalin	PFD	C ₁₀ F ₁₈	462	141-2	0	1.93	6.6
Perfluorohexylsulfur-pentafluoride	L-4412	C ₆ F ₁₃ SF ₅	446	118	-31	1.89	19.5

Source: The Aerospace Corp

Table 5
Physical Properties and Toxicology Data for Potential Vapor Taggants

Vapor Taggant Chemical Name	Abbreviation	Empirical Formula	Molecular Weight	Boiling Point (°C)	Melting Point (°C)	Specific Gravity	Solubility in Water	Vapor Pressure (mm Hg at 300°K)	Toxicity LD 50 **
Perfluoromethylcyclohexane	PMCH	C ₇ F ₁₄	350	76	-37	1.79	25 ppm	106	825ppm/rat 14 hr
Perfluoro-1,2-dimethylcyclobutane	PDCB	C ₆ F ₁₂	300	45	-32	1.671	25 ppm	500	550,000ppm/rat 4 hr
Octafluoronaphthalene	OFN	C ₁₀ F ₈	272	80 at 15mm	87-8	N/A *	N/A *	0.074	N/A *
Perfluorodecalin	PFD	C ₁₀ F ₁₈	462	141-2	0	1.93	25 ppm	6.61	100ml/kg
Perfluoro-1,3-dimethylcyclohexane	PDCH	C ₈ F ₁₆	400	101-2	-70	1.85	25 ppm	35.0	100ppm/rat 14 hr
Octafluorotoluene	OFT	C ₇ F ₈	236	105	20	1.673	N/A *	N/A *	5000ppm/mouse 10 hr
Hexafluorobenzene	HFB	C ₆ F ₆	186	80-1	N/A *	N/A *	N/A *	92.7	12.5ppm/mouse 2 hr

* N/A - Information not available

** LD 50 - Lethal dose for 50% of the test animals

especially in the presence of explosives. Tests have only recently started on the compatibility of explosive materials with either the taggant vapors or the membrane materials”

Table 5 (from Ref 3) contains data on several additional potentially useful fluorocarbons as well as information on toxicity of all these compds

Detailed discussions of vapor taggants in elastomers can be found in Ref 8, and discussions of microencapsulated taggants are in Refs 9 & 10

Sensors for Detection Taggants

Before proceeding with a description of detection sensors, it is instructive to consider OTA’s estimate of targets that might be protected by such sensors. Actually this estimate, shown in Table 6, gives the percentage of targets that *would not be protected*. Very likely this estimate (79%) is too low, since many of the targets, other than residences, commercial establishments and vehicles, are not expected to be provided with detection sensors. Note that the estimate projects that detection tagging and sensing would produce only a very small decrease in bombing victims. However, recall that prevention of a single aircraft bombing could completely reverse this projection. As already stated, airports are prime candidates for the deployment of detection sensors

A vapor detection sensor scheme for people or baggage is shown schematically in Fig 4, taken from Ref 12. As shown, air from the vicinity of the item or person being inspected is collected and delivered to a sensor, after first being conditioned. The sample collector can

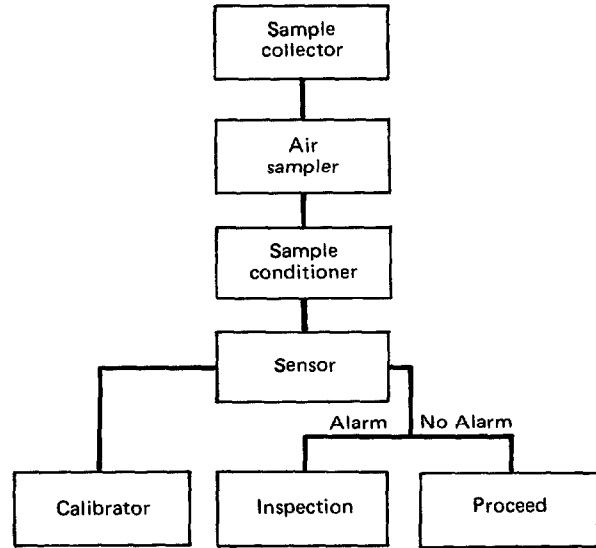

Source: Office of Technology Assessment (Ref 12)

Fig 4 Detection Taggant Sensor System Block Diagram

simply consist of a gust of air for inspection of persons, or can include provisions for delivering a small pressure pulse to packages or baggage in order to introduce more of the air from their interiors into the air sample stream. For some of the sensors, free oxygen and water vapor must be removed in the sample conditioner prior to insertion of the air into the sensor. If vapor taggants are present, an alarm indication is registered; if none are present, the item passes thru without delay. A detailed procedure has not been developed to deal with alarms, but the procedure would probably include a recycle thru the sensor to eliminate the chance of equipment

Table 6
Percent of Bomber Targets That Would Be Protected by a Detection Sensor

	Total Bombings ^a	Injuries	Deaths
Average number of bombings of known, substantial targets ^b . . .	1,175	150	29
Bombings of residences, vehicles	557 (47%)	86 (58%)	21 (72%)
Bombings of commercial establishments	371 (32%)	47 (31%)	6 (22%)
Total unlikely to have sensors	928 (79%)	133 (89%)	28 (94%)

a- Includes both incendiary and explosive bombings for 1977 and 1978

b- Open fields and mailboxes are excluded from these data

Source: BATF data

error, followed by a disposal procedure of the suspected bomb if the alarm persists

At present there are three detection sensor systems in the early development stage. The three candidate detection sensors are, in order of increasing complexity and cost, the *continuous electron capture detector* (CECD), the *ion mobility spectrometer* (IMS), and the *mass spectrometer* (MS). A brief description of these systems follows

An Electron Capture Detector operates as follows: a CECD is essentially a tube thru which a stream of inert gas flows. A weak radioactive source on the walls of the tube irradiates the gas and generates within it a population of free electrons. These electrons are extracted from the gas stream by a positive electrode. The number extracted per second is measured as a current flowing thru this electrode

This small current is normally quite steady, and may be about 10 nanoamperes. If, however, certain impurities are added to the gas stream, the impurity molecules may capture some of the free electrons before they can be extracted by the electrode. The drop in the number of electrons extracted causes a drop in the electrode current; this drop in current signals the presence of the impurity

This system is extraordinarily sensitive and can detect quantities as small as one picogram of impurity. Unfortunately there are two main drawbacks. Firstly, although the system responds well to molecules of expls vapor, *it also responds to a variety of common vapors*. Secondly, it responds to oxygen; this means that vapors to be detected must somehow be separated from the ambient air. Both these problems are overcome by passing the air to be sampled over a specially prepared Pt surface which has the unique property of attracting only molecules of expl substances or appropriate taggants. When the sample airflow has passed over the Pt for a short time, the airflow is replaced by a flow of Argon gas. This removes residual air and also any vapor molecules not closely bound to the Pt. Finally, the Pt is heated electrically, and any vapor molecules clinging to it are driven off and carried by the Argon flow into the current sensing element. The time response of this device is of the order of several seconds. The current from the sensing element can be ampli-

fied and used to trigger visual or audible alarm signals

One of the disadvantages with these detectors is the use of the carrier gas, Argon, which if not of the highest grade could cause the detector to false alarm. An alternative system operates on a different principle. Air is drawn continuously thru the instrument by a small fan. Electrons are sprayed into the airstream by means of a high voltage discharge. Most of these electrons are captured by oxygen molecules to produce negative ions, but some are transferred to any expls vapor molecules which may be present, turning them into ions. The ion-laden air then passes thru a section thru which only heavy ions, such as are formed from expls vapor molecules, or vapor taggants, can pass. At the end of this section any such ions are collected by an electrode, and form a small current which is amplified and used to change the pitch of an audible note. Such a device can be considerably more compact than the Argon stream system, and it has a faster response (Ref 11)

Brookhaven National Laboratories (BNL) has constructed an electron-capture detector capable of direct air sampling. The electron capture detector follows a catalytic reactor that contains H_2 and Pd/Molecular Sieve 5A at 140° . This reactor effectively removes oxygen from the air sample stream by forming water. Additionally, chlorofluorocarbons are combusted and reduced to HCl and HF. These acids, along with H_2O , are removed from the sample stream via a desiccant. However, such gases as SF_6 and perfluorinated cyclic aliphatics [perfluorodimethylcyclobutane (PDCB), perfluoromethylcyclohexane (PMCH), and perfluorodimethylcyclohexane (PDCH)] survive the reactor and are detected via an electron capture device. These chemical compds survive due to their unusual thermal stability. BNL has demonstrated a lower limit of detection of these compds with their bread-board instrument (on a continuous sampling mode) of 0.1 parts per trillion (Ref 12)

The ability to detect tagged expl products in a controlled-access scenario is the final objective of the vapor taggant development effort. To accomplish this, there are three steps: (1) placement of the taggant in an expl product; (2) extraction of the vapor taggant from the test object; and (3) use of a detector of sufficient

specificity and demonstrated lower limit of detection to detect the taggant

BNL personnel conducted a preliminary test at the US customs facilities to monitor taggants in processed baggage using vapor-tagged blasting caps (taggants: perfluorodimethylcyclobutane and perfluoromethylcyclohexane absorbed in Viton). Luggage pieces containing the tagged dummy electric blasting caps were placed on the conveyor belt (belt speed 1.0 ft/sec of the US customs baggage examiner, and encountered pressure fingers (4 lbs) on two sides and on top. The displaced internal suitcase volume was passed thru the detector at 1 liter/min. Tagged blasting caps (0.3- to 100-ml/min emission rates) were placed in baggage 15 to 65 mins prior to scanning. Taggants were detected in all situations, even with a cap emitting only 0.3ml/min placed in the luggage just 15 mins prior to passage thru the system

The IMS system is in effect a modification of the CEDC system. It distinguishes ionized molecules on the basis of differences in their drift velocity as they pass countercurrent thru a flowing gas stream. An electric field provides the driving force for the flow of ionized molecules

All the taggant molecules being considered have long drift times and are easily separated from common gases in the IMS. Additional

specificity is gained by the inertness of the taggants; most other large molecules fragment in processing thru the detector. A schematic diagram of an IMS system is shown in Fig 5

The mass spectrometer (MS) is a standard lab instrument, easily capable of distinguishing the taggant molecules from other species. Current MS's, however, are expensive and sensitive lab instruments. The challenge is to design and develop a low-cost, field-usable instrument that will detect taggant molecules in a parts-per-trillion concn level

Although cost of tagging explosives will be considered in Section VI, it is appropriate to present (Table 7) OTA's estimates of the cost of detector systems

In addition to instrument costs there are other costs associated with detector systems. These additional cost items are shown in Fig 6. OTA's estimates of the total annual cost of detector systems as a function of systems deployed is shown in Fig 7 (Ref 12)

According to OTA (Ref 12):

"None of the detection sensor concepts has yet passed the technical feasibility demonstration milestone. The only time estimate which has been made is an extremely optimistic estimate of 14 months from demonstration of technical feasibility to completion of a proto-

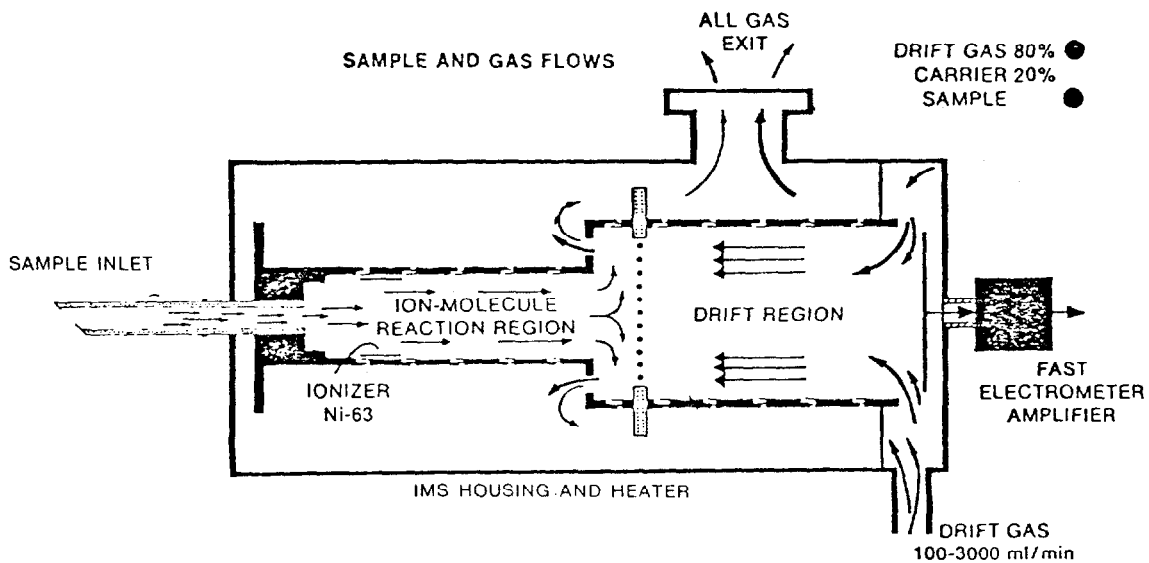
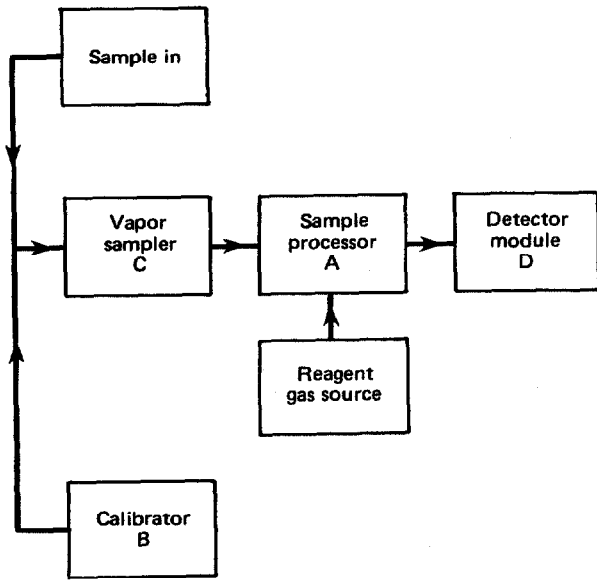

Fig 5 Ion Mobility Spectrometer (IMS) System

Table 7
Vapor Taggant Detector System Cost (annual cost per unit)

Hardware investment	Continuous electron capture device	Ion mobility spectrometer	Mass spectrometer
Cost per unit	\$12,355	\$15,160	\$35,270
Installation and checkout	500	500	500
Hardware subtotal ^{-a}	12,855	15,660	35,770
Annual cost of investment per unit ^{-b}	2,082	2,537	5,795
Annual maintenance	1,236	1,516	3,433
Cost of false alarm @ .01% rate	0	0	0
Total annual cost per detector	\$ 3,318	\$ 4,053	\$ 9,228

a- Includes cost of training operating personnel
 b- Estimated 10-year life and 10-percent interest rate
 Source: Office of Technology Assessment (Ref 12)



Total Cost = A + B + C + D

Source: Office of Technology Assessment (Ref 12)

Fig 6 General Functional Network for Vapor Taggant Detector

• Hardware cost only

$$\bullet \text{ Annual cost} = (P-S) \left[\frac{i}{(1+i)^n - 1} + i \right] + SI$$

where: P = first cost
 S = salvage value (assumed 0)
 n = equipment life (estimated 10 years)
 i = interest rate (estimated @ 10 percent)

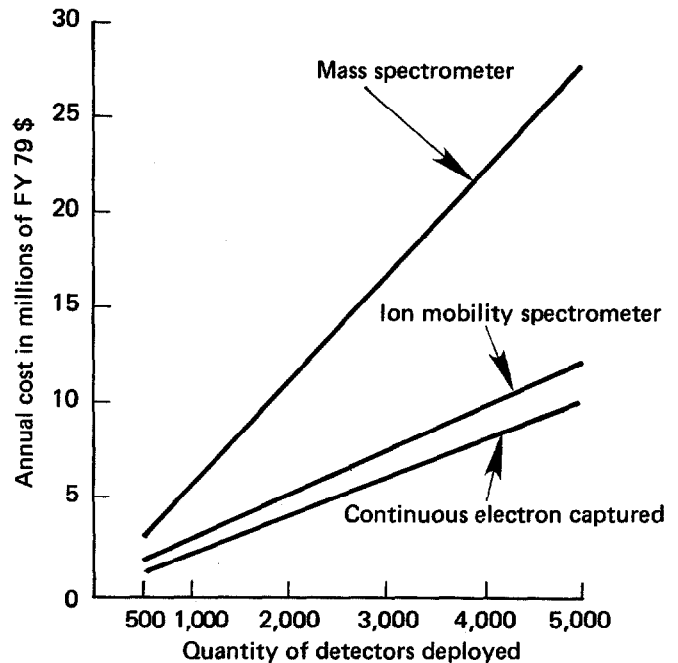

Fig 7 Estimated Annual Vapor Taggant Detector Cost vs Quantity Deployed

type. The estimate assumed no technical, contractual or other problems, and may well be off by a factor of two. Given the fact that these instruments would be produced in quantity (up to several thousand), must be self-calibrating, maintained by routine maintenance people, and detect at the parts per trillion level, it is unlikely that production could be underway in less than five years”

V. Effectiveness of Explosive Tagging

This is a subject of bitter controversy. BATF, its contractors and a large segment of the law enforcement community are strongly advocating that Congress pass legislation to make the use of taggants in expls mandatory. Strongly opposed to this legislation are expls and proplnt manufacturers and associations of users of sporting powders for hunting or target shooting. A bill, S 333, now under consideration by the Senate Committee on Governmental Affairs, proposes the tagging of all expls and proplnts. This would include tagging of the enormous amounts of blasting agents (ANFO) that are currently produced, even though BATF, the bill's greatest proponent, originally requested that only cap-sensitive materials be tagged. As discussed in the next section, inclusion of blasting agents in the tagging program will greatly increase the cost of the program

Ideally the following fundamental questions should be answered before a tagging program is mandated:

- Under optimum conditions, how effective is tagging in reducing criminal bombings?
- Does the projected effectiveness justify foreseeable program costs?
- Is the state of development of tagging sufficiently advanced to permit immediate or near-future legislative action?

Unfortunately seeking answers to at least two of the above questions is an exercise in futility. Taggant effectiveness is undoubtedly the most controversial and least definable area of the tagging program. Tagging expls can increase the current low arrest and conviction rate of criminal bombers and consequently also deter potential bombers (identification tagging). Detection tagging, though highly limited in applicability, can further reduce the bombing threat by detection of devices before they expld and also act as

a deterrent. Even if one assumes that all the “bugs” in the tagging program are overcome, there are *no quantitative criteria* by which the effectiveness of expl tagging can be gaged. What one has to rely on (since the Oracle of Delphi is no longer operating) are oracular predictions from the law enforcement community, governmental agencies and other sources

The functioning of a viable detection tagging system in reducing bombings is obvious, though the degree of reduction of bombings by this system is largely a matter of guesswork. Identification tagging becomes operative only after an expln and during the search for the perpetrators. The post-expln investigative phase consists primarily of trying to generate some type of lead to the perpetrators from the physical evidence gathered, as well as tracking leads provided by informants or witnesses, and attempts to correlate the characteristics of the bombing with similar instances. Thus, a great deal of effort may be expended

The addition of identification taggants to expls would aid the investigatory efforts in a number of ways, provided that the taggants survive the detonation and are recoverable from the expln debris. If the bombing is of sufficient importance (in terms of property damage, notoriety generated, or casualties produced) to warrant a thorough investigation, identification taggants will provide more definitive information with less effort by the investigating team. Equally important, the information can be made available quickly — in a matter of hours, if necessary, rather than the days or weeks it may take to generate whatever data can be generated by conventional means. The taggants provide a good starting point for an investigation, as they directly indicate the type of expl used, manufacturer, and time of manufacture, and provide a list of the last legal purchasers. This information may lead directly to a bomber who purchased the expls legally, provide a limited number of suspects for intensive investigation, tie reported thefts of expls to bombings, provide leads to unreported thefts of expls, or provide indirect information to limit the scope of an investigation to a specific geographical region of the country. Furthermore, the rather rapid inflow of information to the investigators may be a strong motivating force for a determined

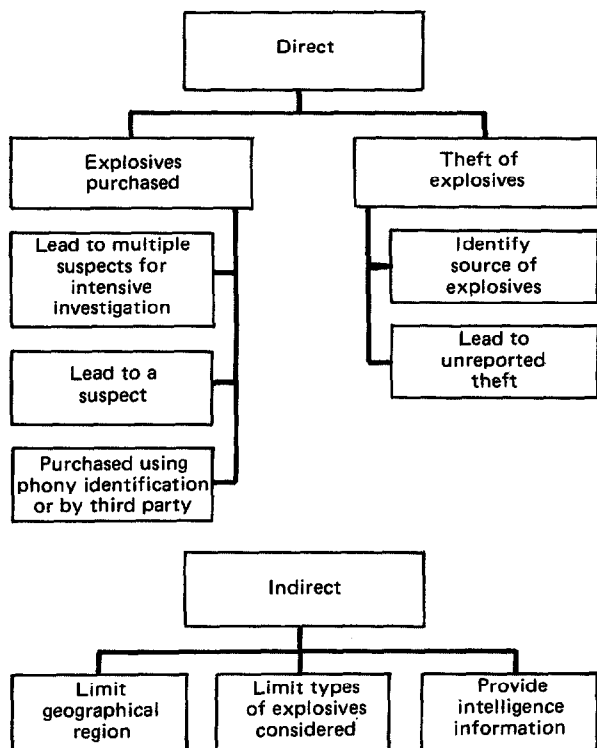

Fig 8 Schematic Illustration of Identification Taggant Utility in Criminal Investigation

effort on their part. Lack of early information during the investigation of a crime often frustrates the investigators and tends to divert their attention to other more promising investigations. Identification taggant information can also provide important evidence during trials of suspected bombers

OTA has schematically summarized the foreseeable utility of identification tagging in criminal investigation as shown in Fig 8 (Ref 12)

There are several factors that can appreciably reduce the utility of identification as well as detection tagging. The effectiveness of the latter can be degraded by hermetic sealing of the expl (since detection is predicated on sensing volatile taggants), as well as deliberate use of vapors that can trigger the detection sensors and create false alarms. As to identification tagging, taggants can be removed from the expl (eg, by magnetic, gravity or screening separation), or criminals can go over to the use of home-made expls. Moreover, there is a large backlog of

stolen untagged expls, some of which undoubtedly are in the hands of criminals, and can be used in future bombings. Clearly there is no "track-record" upon which to base quantitative estimates of the effectiveness of either identification or detection tagging in reducing criminal bombing

Incidentally, according to OTA, there are two exactly opposite schools of thought with regard to the use of countermeasures by criminal bombers. Every person knowledgeable in expls contacted by OTA believed that countermeasures would be employed. Every behavioral psychologist and many law-enforcement people thought that countermeasures would not be used to any appreciable extent

Cost factors of expl tagging will be considered in the next section. In view of the above discussion, recalling that there can be serious compatibility problems of currently preferred taggants and expls, and considering that detection tagging is still in its infancy, it seems that immediate or near-future Congressional action to make tagging mandatory would be premature

VI. Tagging Costs

This is another controversial area in that cost estimates by proponents of tagging are probably unduly optimistic and estimates by opponents are unduly pessimistic. A recent OTA survey addressed this subject in detail (Ref 12)

The primary methodology utilized in OTA's cost analysis was to translate all program costs, both nonrecurring one-time costs and recurring costs, to annualized values. Capital investment costs were annualized over a 10-year period at an interest rate of 10%. This method was utilized for all initial expenditures (requalification, waste facilities, etc) with the exception of tooling costs estimated for detonators and blasting caps, which were written off in a 5-year period at 10% interest. All costs are given in 1979 dollars

The various cost elements considered by OTA are shown in Fig 9. As expected, the taggant program costs were found to vary substantially as a function of the level of implementation of the program. OTA assumed a "baseline" level of implementation and developed cost estimates for this baseline program. Parametric variation of the costs were then examined as a function

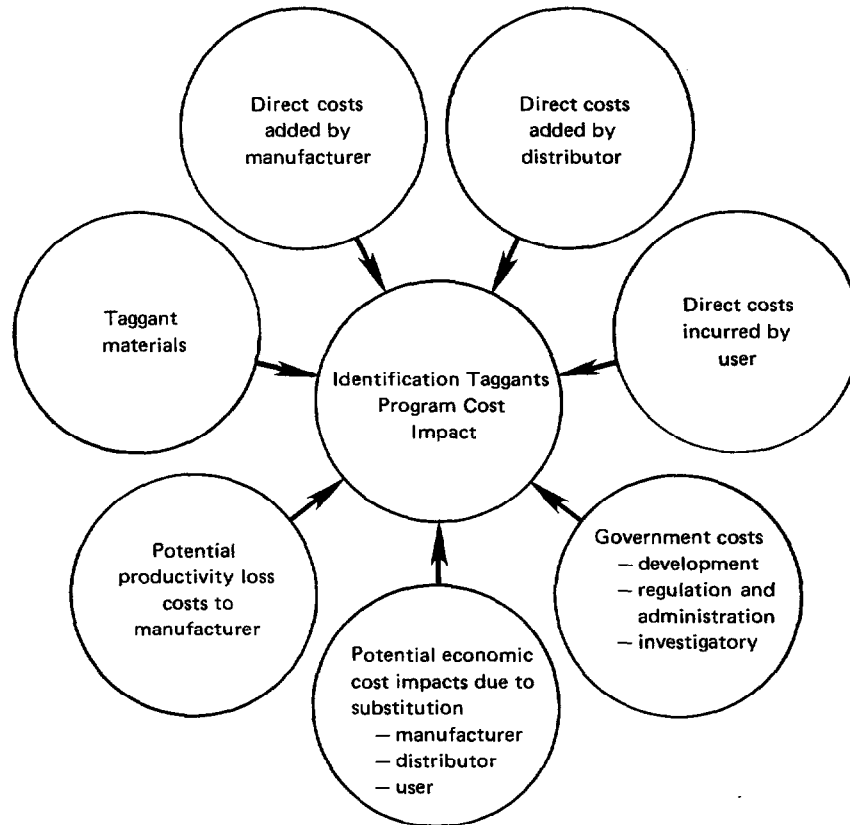

Fig 9 Schematic Illustration of General Cost Element Sources

Table 8
Taggant Program Summary Annual Cost-Baseline
Program (millions of FY 1979 dollars)

	Annual cost
Taggant materials	\$20.56
Identification taggants (11.22)	
Detector taggants (9.34)	
Sensor-related costs ^a	6.83
Explosives manufacturers' added costs	7.07
Distributors' costs	9.23
Government costs	1.68
Administration and tracing	
Taggant program development	
Increased investigative costs	0
Total baseline program annual cost . .	\$45.37

a- Assumed 1,500 units, 90-percent IMS and 10-percent MS

of higher and lower level implementation plans. The total annual baseline program costs, as shown in Table 8, amount to 45.4 million dollars

This cost is predicated on unencapsulated taggant levels of 0.025% for both identification and detection tagging for the major expl categories, and a price of \$55/lb for the former and \$40/lb for the latter

OTA cost estimates for a low level program (identification tagging per plant year; fewer detectors deployed than in baseline program) and a high level program (smaller batches tagged than in baseline program, 5000 detectors deployed; *ANFO tagged!*) are shown in Table 9

It is obvious that inclusion of blasting agents (ANFO) in the tagging program greatly increases program costs

OTA's estimated costs attributable to identification tagging as well as detection tagging are shown in Table 10

Table 9
Taggant Program Summary Annual Cost Versus Implementation Level
 (millions of FY 1979 dollars per year)

Summary cost elements	Low case program	Baseline program	High case program
Taggant materials			
Identification taggants	\$ 5.61 ^a	\$11.22	\$11.22
Detection taggants	9.34	9.34	9.34
Explosive manufacturers' added cost	5.26 ^b	7.07 ^c	19.41 ^d
Distribution system added cost	5.02 ^e	9.23	16.55 ^f
Public overhead	5.32 ^g	8.51 ^h	24.5 ⁱ
Total program annual cost	\$30.55	\$45.37	\$81.0
			(less ANFO)
			\$187.0 ^j
			\$268.0

a- OTA estimate of simplified code based on halving the baseline estimate

b- Plant/year tagging level

c- Date-shift tagging level

d- 10,000 to 12,000-lb tagging level for cap-sensitive; 2,000-lb for powders

e- Includes markup costs only

f- Includes increase for: adjusted markups; 7.5 million lbs of powders; powder recordkeeping @ \$1/lb

g- Based on 800 sensors

h- Based on 1,500 sensors

i- Based on 5,000 sensors

j- Based on: 3.4 billion lbs of ANFO tagged annually; ID tag @ 2¢/lb of ANFO; detection tag @ 0.5¢/lb of ANFO; manufacturing @ 2¢/lb of ANFO; and recordkeeping @ 1¢/lb of ANFO

Source: Office of Technology Assessment (Ref 12)

As already mentioned, cost estimates vary greatly with the agency that makes the estimate. This is illustrated in Table 11

It is instructive to consider how costs are apportioned to the various facets of the tagging programs, what impact total costs will have on the price of expls, and what expl user reaction might be to this increase in price. Tables 12 and 13 show material costs for the "baseline" identification and detection programs respectively. These costs are broken down by type of expl tagged

OTA's estimates of the costs to produce and distribute tagged expls (baseline program) as shown in Tables 14 and 15 as a function of type of expl. Costs of record-keeping, obviously a very necessary function for a successful tagging program, are included. Note that these costs, as expected, depend strongly on the poundage of expls or number of items tagged

Table 10
Summary Program Costs Versus
Level of Implementation

	Identification	Detection	Total combined program ^a
Low	\$ 14.93	\$21.92	\$ 30.55
Baseline . .	24.76	25.44	45.37
High	214.54	65.26	268.8

a- Combined program costs are less than the sum of the individual programs because of shared labor, tooling, administration, etc

Source: Office of Technology Assessment (Ref 12)

Table 11
Comparison of the Estimates for ID Tags
(millions of dollars per year)

Cost elements	IME cost estimate	OTA estimates using IME assumptions ^{-a}	OTA estimates using OTA assumptions
ID tag materials – non-ANFO	\$ 52.5	\$ 10.38	\$ 11.2
ID tag materials – ANFO	340.0	68.0	68.0
Manufacturers' costs – non-ANFO	–	17.2	18.47
Manufacturing cost – ANFO and recordkeeping	–	102.0	102.0
Distribution system cost	–	8.0	13.98
Public overhead	–	.87	.87
Recordkeeping costs	19.5	in mfg & distribution	in mfg & distribution
Code reservation	291.1	–	–
Total	\$703.1	\$206.45	\$214.54

a- Assumptions: 275 million lbs of cap-sensitive packaged explosives, 2.5 million lbs of black powder, smokeless powder not included

Source: Office of Technology Assessment (Ref 12)

From the point of view of the manufacturer or user, the important criterion is the additional cost that tagging expls will necessitate in the market place. OTA's estimates, shown below, project a substantial cost increase for all expl categories (except possibly BlkPdr):

Explosive category	Percent cost increase
Cap-sensitive packaged high explosives . . .	11.9
Boosters	17.6
Black powder	2.3
Smokeless powder	11.8
Detonating cord	23.5
Blasting caps	15

Such cost increases can produce a large impact on the amounts of various expls sold, if as expected this price increase will be passed on to the consumer. Cap-sensitive expls are already suffering a substantial decline in use relative to blasting agents primarily because of their higher price. An additional increase in the cost of cap-sensitive expls can result in a further drop in their consumption. This could hurt medium-sized expl manufacturers whose product lines are primarily cap-sensitive. Incidentally, the expls market is highly competitive and users have little

or no product loyalty. It is the rule rather than the exception that a small reduction in price will make the user switch to the less costly product

There is another somewhat esoteric cost associated with tagging of expls, namely liability in law suits resulting from expl accidents. It is probable that plaintiffs' lawyers will try to attribute accident cause to the inclusion of taggants. How courts will react to such allegations and who may be found liable is uncertain at this time. However, it is conceivable that such liability costs can be large

We have examined tagging costs at some length, but so far we have not compared these costs to the dollar loss resulting from criminal bombings. In addition to numerous other difficulties, estimating the cost of criminal bombings entails the valuation of loss of life and injury in terms of dollars. The writer and his associates (Ref 2) made a cost-benefit study of explosive tagging. They concluded the following:

Annual bombings costs over the next 20 years are expected to stay constant if the tagging programs are not implemented. The constant annual direct costs of the projected bombing threat are expected to be: 15 million dollars for property damage, 30 million dollars for bombing fatalities

TABLE 12
Identification Taggant Material Annual Costs, Baseline Program

	Estimated annual production	Explosive average unit cost	Taggant concentration	Encapsulated/unencapsulated (total pounds)	Taggant cost per pound	Increased cost per unit of explosives	Increase in explosive cost	Annual cost for taggant materials (dollars in thousands)
Cap-sensitive packaged high explosives	325 million lbs	\$0.50/lb	0.05%	Encapsulated (162,500)	\$ 55	2.75¢	5.5%	\$8,900
Cast boosters	6 million lbs	\$1.50/lb	0.1%	Encapsulated pellets (6,000)	122	12.2¢	8.1%	732
Smokeless powders	5 million lbs	\$6.00/lb	0.05%	Encapsulated (2,500)	55	2.75¢	0.46%	137
Black powder	400,000 lbs	\$9.00/lb	0.05%	Encapsulated (200)	55	2.75¢	0.30%	11
Detonating Cord	500 million ft	5¢/ft	5 taggants per inch	Encapsulated (160)	25/batch	0.05¢	1%	250
Blasting caps	84 million units	50¢ each	50 mg	Encapsulated (9,240)	120	1.32¢ each	2.64%	1,100 (+46) ^a
Total program								\$11,200

a - Allowance for cap materials
Source: Office of Technology Assessment (Ref 12)

Table 13
Detection Taggant Material Annual Costs

Explosive category	Estimated annual production	Detection taggant level concentration	Detection taggant required, pounds	Taggant cost per unit explosives (@ \$40/lb taggant)	Expected total annual costs (dollars in thousands)
Cap-sensitive packaged high explosives	325 million lbs	0.025% by weight	87,500	1¢	\$3,250
Cast boosters	6 million lbs	0.025% by weight	1,500	1¢	60
Smokeless powders	5 million lbs	0.025% by weight	1,250	1¢	50
Black powder	400,000 lbs	0.025% by weight	100	1¢	4
Detonating cord	500 million ft	100 mg/ft	110,000	0.9¢	4,500
Blasting caps	84 million units	200 mg/cap worst case set	36,960	1.76¢	1,478
Total					\$9,340

Source: Office of Technology Assessment (Ref 12)

Table 14
Manufacturing Cost Added

Explosive category	Estimated annual production	Manufacturing cost added/unit	Total program manufacturing cost added (dollars in thousands)
Cap-sensitive packaged high explosives	325 million lbs	1.03¢ ^{-a}	\$3,347
Boosters	6 million lbs	7.72¢	463
Black powder	400,000 lbs	2.57¢	10
Smokeless powder	5 million lbs	2.57¢	128
Detonating cord	500 million ft	0.094¢	470
Blasting caps	84 million units	3.15¢	2,650
Total			\$7,068

a - Baseline conditions

Source: Office of Technology Assessment (Ref 12)

Table 15
Distribution System Cost Added

Explosive Category	Estimated annual production	Distribution system cost added/unit	Total program distribution system cost added (dollars in thousands)
Cap-sensitive packaged high explosives	325 million lbs	1.19¢ ^{-a}	\$3,869
Boosters	6 million lbs	5.48¢	328
Black powder	400,000 lbs	7.55¢	30
Smokeless powder	5 million lbs	64.43¢	3,222
Detonating cord	500 million ft	0.15¢	750
Blasting caps	84 million units	1.23¢	1,033
Total			\$9,232

a - Baseline conditions

Source: Office of Technology Assessment (Ref 12)

and 6 million dollars for bombing injuries, or, rounded off, total annual direct cost of 50 million dollars

The estimated indirect costs are expected to be (annually) 45 million dollars for bombing investigations and bomb disposal, 15 million dollars for the cost of evacuations and delays due to bombing threats, 10 million dollars for security guards employed because of bombings, 5 million dollars for judicial proceedings against

arrested bombers and their incarceration costs, and 2 million dollars for disruption of vital services. The total amounts to 77 million dollars, but since these indirect costs are uncertain this estimate is rounded off to a total indirect cost of 80 million dollars. All of the above estimates are in 1976 dollars and no attempt has been made to project the effect of inflation

Program costs were estimated to be 10 million dollars annually for identification tagging and an

average annual cost (over 20 years) of 9.4 million dollars for detection tagging. Because a major cost in detection tagging is for detection equipment, which must be replaced periodically, only an average annual cost could be defined for this program. These costs were based on information provided by Aerospace Corp and in view of the recent OTA study they are considerably too low

A cost-benefit analysis relates the cost of implementing a program to the reduction in social costs realized by the program. A convenient and frequently used end-product of such an analysis is the so-called benefit/cost ratio. Basically, this ratio is the reduction in social costs (benefits) realized by the project over a fixed number of years (customarily 20 years) divided by project costs over the same time period

To estimate the reduction in social costs of a program requires some knowledge of the effectiveness of the program. Since there was (and still is) no "track-record" of the effectiveness of tagging expls, a mathematical model was developed in which program effectiveness and consequently cost benefits are presented in parametric form in terms of the parameters based largely on qualitative opinions of law enforcement personnel

For identification tagging the parameters chosen to represent achievable effectiveness were an increase in current low arrest rate by 1.5-fold and an annual deterency rate of 5%. With these assumptions, and what now appear to be unrealistically low values of program cost, favorable benefit-cost ratios (appreciably greater than one) were obtained for identification tagging. Thus, identification tagging appeared to be worthwhile from an economic point of view

Definition of a "realistic" range of effectiveness for detection tagging (as it applies to the overall expl threat) is much more uncertain than for identification tagging. Within this large uncertainty, it appeared that detection tagging is not worthwhile from an economic point of view, but may still be justifiable in terms of its potential to reduce very infrequent but very costly bombings

Based on the low program costs used in the study, it was estimated that the combined identification and detection tagging programs give favorable benefit/cost ratios, since the favorable

costs benefits of identification tagging more than counteract the unfavorable economics of detection tagging

These conclusions have to be modified if one accepts the more recent estimate of program costs, but retains the bombing costs and effectiveness estimates of Ref 2. Using OTA's costs for the "baseline" program, identification tagging becomes barely worthwhile from the economic point of view, and the combined identification-detection programs are no longer economically worthwhile. It should be emphasized that economics should not be the sole consideration upon which to judge the desirability of tagging expls

Written by J. ROTH

Refs: 1) F.P. Bowden & A.D. Yoffe, "Fast Reactions in Solids", Academic Press, NY (1958)
 2) J. Roth, "Evaluation of the Needs & Benefits of the Explosives Tagging Program", Final Report for US Bureau of Alcohol, Tobacco and Firearms (March 1978)
 3) E. Achter et al, "Explosives Tagging & Control", 2nd Annual Report, Aerospace Corp (Oct 1978)
 4) G.N. Roberts, Proc Symp on Detection & Identification of Explosives, Reston, Va (Nov 1978), 475
 5) D.J. Edwards & G.H. Fuller, *Ibid*, 539
 6) C. Boyars, *Ibid*, 521
 7) S.R. Silva et al, *Ibid*, 459
 8) G.I. Senum et al, *Ibid*, 499
 9) M.S. Tay & R.S. Stringham, *Ibid*, 507
 10) Z. Reyes & J.H. Smith, *Ibid*, 515
 11) J.A. Reed, *Ibid*, 191
 12) P. Sharfman et al, "Taggants in Explosives", OTA (Office of Technology Assessment, US Congress, Washington, DC) Report (1980)

TAGN (Triaminoguanidine Nitrate, Triaminoguanidin-nitrat, Nitrate de Triaminoguanidine). $\text{CH}_9\text{N}_7\text{O}_3$;

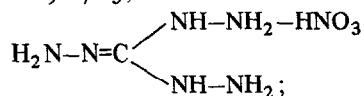

mw 167.14; colorl crysts; N 58.67%; OB to CO_2 -33.50%; OB to CO -23.95%; mp 216° (decompn); deflagration pt 227° ; expln temp 260° ; d 1.5g/cc

The thermochemical parameters for TAGN are: Q_f +11.71kcal/mole; Q_c 2334cal/g or 389.78kcal/mole; Q_e 920.98cal/g; vol of deton gases 1206l/kg; E_v (2500°K) +31cal/g; C_v 0.4208cal/g/ $^\circ\text{K}$; Isochoric flame temp, T_v 2573.4°K ; force 275.54 mole-cal/g; and isobaric flame temp, T_p 2051°K

TAGN has an impact sensy of 11 inches using a 2-kg wt (PicArns app); Trauzl Pb block test, 350cc/10g; Sand test (200g) value, 34.9g; deton vel 5350m/sec (d 1.00g/cc) and 7930m/sec (d 1.46g/cc)

Its solubility in water in g/100g is 1.47 at 0° , 4.5 at 25° , and 22.0 at 65° ; it is not hygroscopic at up to 90% RH at 70°F ; stability data is shown below:

120° Heat test	SP, +300 min
100° Heat test, % wt loss	
1st 48 hrs	0.15
2nd 48 hrs	2.73
100 hrs	no expln
Vac Stab test, 120°, cc gas	1.06
(Refs 3, 4, 5 & 18)	

TAGN can be prepd by reacting one mole of guanidine dinitrate with three moles of hydrazine hydrate at 100° for four hrs. The reaction is accompanied by the liberation of ammonia (Ref 18). It can also be prepd by the aq fusion of hydrazine nitrate and Ca cyanamide (Ref 4)

TAGN has been used primarily as an oxidizer in cool-burning gun proplnts for rapid fire weapon systems (Refs 6 to 17, 19 to 27 & 29 to 37)

Accdng to Ref 38, TAGN is generally bacteriostatic at concns > 100ppm; it is not, however, a bactericide. Moreover, some bacteria are capable of degrading or at least removing TAGN from aq soln, hence offering a means of disposal of TAGN-contg proplnt compns. Ref 39 concludes that open air burning of proplnt contg TAGN is safe, inasmuch as the resultant pro-

duction of toxic CO and CH_4 gases are not appreciably different than that obtained from proplnt not contg TAGN

There are several expl salts of TAGN which are of interest:

Triaminoguanidine Perchlorate (TAG perchlorate). $\text{CH}_9\text{N}_6\text{ClO}_4$; mw 333.0; N 37.8%; OB to CO_2 -60.0%; ndles; mp 132° ; d 1.09-1.62g/cc (range). Prepn is by hydrazinolysis of aminoguanidine sulfate, and treatment of the product with Ba perchlorate

TAG perchlorate has a deton vel of 7730 m/sec (d1.56g/cc) and 5970m/sec (d 1.09g/cc); is friction sensitive; can be detonated with a BlkPdr fuse; Q_c 1013.62kcal/mole, Q_e 513.1 cal/g; Q_f +20.49kcal/mole; Trauzl Pb block test value, 465ml; Sand test (200g) value, 51g; impact sensitivity (PicArns, 2-kg wt), 3"; and is hygroscopic (Refs 3 & 4)

Triaminoguanidine Picrate (TAG picrate). $\text{CH}_8\text{N}_6+\text{C}_6\text{H}_3(\text{NO}_2)_3$; mw 204.5; N 41.1%; OB to CO_2 -19.5%; ndles; mp $170-71^\circ$; d 1.668g/cc. Prepn is by addn of an aq soln of PA to a TAG salt

TAG picrate has a Q_c of 419.61kcal/mole; Q_e 1227.7cal/g; Q_f -18.2kcal/mole; expln temp, 215° ; 120° vac stab value (5g sample), 1.45cc; Sand test (200g) value, 44.6g; impact sensitivity (PicArns, 2-kg wt), 9"; and is hygroscopic (Refs 3 & 4)

Refs: 1) Beil - not found 2) W.F. Sager & D.V. Sickman, "Second Report on Research and Development in New Chemical High Explosives", **NAVORD 483** (1952), 6 3) L.F. Audrieth & G.C. Hale, USP 2929698 (1960) & CA **54**, 12588 (1960) 4) J.P. Picard et al, "A New Method for Preparing Triaminoguanidine and Its Derivatives", **FRL-TR-10** (1960) 5) W. Sauer-milch, Explosivst **1964** (No 9), 197-99 & CA **62**, 5133 (1965) 6) A.T. Camp et al, USP 3634158 (1972) & CA **76**, 74452 (1972) 7) V.E. Haury & M.B. Frankel, USP 3732131 (1973) & CA **79**, 33282 (1973) 8) J.E. Flanagan & V.E. Haury, USP 3732130 (1973) & CA **79**, 33284 (1973) 9) See Ref 7 10) B.K. Moy, "Thermochemical Evaluation of Advanced Gun Propellants", **AFATL-TR-73-244**, Eglin AFB (1973) 11) See Ref 7 12) C.E. Johnson & L.D. Henderson, USP 3758325 (1973) & CA **80**, 60566 (1974) 13) J.P. Picard et al, USP 3813439 (1974) & CA **81**,

- 93619 (1974) 14) Not used 15) J. Zucker et al, USP 3867214 (1975) & CA **83**, 63047 (1975) 16) V.E. Haury et al, GerP 2263860 (1974) & CA **82**, 5783 (1975) 17) J.P. Flynn et al, USP 3865659 (1975) & CA **83**, 45509 (1975) 18) R. Meyer, "Explosivstoffe", Verlag Chemie, Weinheim, Ger (1975), 262
- 19) Anon, FrP 2221423 (1974) & CA **82**, 173244 (1975) 20) V.E. Haury et al, BritP 1362506 (1974) & CA **82**, 75166 (1975)
- 21) V.E. Haury & M.B. Frankel, CanP 977154 (1975) & CA **84**, 108006 (1976) 22) J.E. Flanagan & V.E. Haury, CanP 977155 (1975) & CA **84**, 108005 (1976) 22a) O.K. Heiney, "Interior Ballistic and Combustion Problems Associated with Advanced Composite Gun Propellants", Inst Chem Treib Explosivst, 269-84 (1975) & CA **87**, 25499 (1977) 23) Ibid, USP 3909323 (1975) & CA **84**, 46849 (1976)
- 24) Ibid, BritP 1432327 (1976) & CA **85**, 179845 (1976) 25) Anon, FrP 2293424 (1976) & CA **86**, 157835 (1976) 26) K.B. Reynolds, "Manufacturing Methods for TAGN", Rept **R76-139**, AFML-IR-312-6 (II) (1976) & CA **86**, 19154 (1976) 28) F.B. Wells, "High Energy Flexible Explosive. I. The Dynamite Grade Nitrocellulose/Trimethylolethane Trinitrate Binder System", PATR **4846** (1976)
- 29) M.G. Baldwin, USP 3957549 (1976) & CA **85**, 96631 (1976) 30) M.B. Frankel & C.A. Dickinson, USP App 747785 (1976) & CA **84**, 135145 (1976) 31) W.A. Rains et al, USP 3971681 (1976) & CA **85**, 162931 (1976)
- 32) L. DeLuca et al, "Radiative Ignition of Double-Base Propellants. I. Some Formulation Effects", AIAAJourn **14** (7), 940-46 (1976) & CA **85**, 126780 (1976) 33) Ibid, "Radiative Ignition of Double-Base Propellants. II. Pre-ignition Events and Source Effects", AIAAJourn **14** (8), 1111-17 (1976) & CA **85**, 162869 (1976) 34) M.S. Chang et al, USP 3954528 (1976) & CA **85**, 162927 (1976) 35) R. Aries, FrP 2275454 (1976) & CA **85**, 123777 (1976) 36) V.E. Haury, BritP 1428348 (1976) & CA **85**, 77698 (1976) 37) Ibid, USP 3950421 (1976) & CA **85**, 20641 (1976)
- 38) M.A. Patrick, "Toxicological and Recalcitrant Properties of a Proposed Propellant Ingredient, Triaminoguanidine Nitrate (TAGN). I. Microbiological Study", AFATL-TR-76-139, Eglin AFB (1976) (AD-A037180) 39) M.A. Patrick & T.G. Floyd, "Ibid. II. Analysis of the Deflagration By-Products of a TAGN-Based Propellant", AFATL-TR-76-161, Eglin AFB (1976) (AD-A041050) 40) D.D. Harrison, "Ibid. III. Toxicity to Drosophila Melanogaster", AFATL-TR-77-46, Eglin AFB (1977) (AD-A047987)
- Taliani Test.** A manometric thermal stability test for NC and proplnts, described earlier in Vol 1, XXIV to XXV, with its many modifications. In all modifications of the method the test tube containing the sample preheated to the desired temp (135° for NC, 110° for proplnts) is evacuated, and the increase in pressure produced by the gaseous decompn products is measured with a Hg manometer. The test is usually terminated when the pressure has attained 100mm Hg
- Clear (Refs 2 & 3) describes the app and procedure in use at PicArns
- Meyer (Ref 4) points out that, "the sample must be thoroughly dried before the test; otherwise the result would also include all other components which increase the pressure on being heated, such as w and organic solvents. Since the result is also affected by the NG content of the proplnt sample, the test can only be used in order to compare proplnts of the same kind with one another. This, in addition to the high testing temp, makes the applicability of the Taliani tests to proplnts questionable. Another disadvantage is the necessity for a thorough drying, since in the course of the drying operation the test sample is altered in an undesirable manner, and the exptl stability data may show better values than would correspond to its true stability. The last-mentioned objection does not apply to NC testing"
- Urbański (Ref 1) notes that, "the method . . . is very useful, although by working under relatively elevated pressure it creates specific conditions which differ from those existing during the storage of expls"
- Refs: 1) Urbański **2** (1965), 28 2) Anon, "Propellants, Solid: Sampling, Examination and Testing", MIL-STD-286B, Method 406.1.2 (1967) 3) A.J. Clear, "Standard Laboratory Procedures for Determining Sensitivity, Brisance, and Stability of Explosives", PATR **3278** Rev 1 (1970), 25-27 4) R. Meyer, "Explosives", Verlag Chemie, NY (1977), 257

Talos. US ship-launched surface-to-air and surface-to-surface missile (military designations run from RIM-8A to RIM-8J). The basic missile is a beam-rider with a semi-active homing terminal phase with control by pivoted wings. Propulsion is by a tandem jettisonable solid-propellant booster and 40000hp ramjet sustainer motor, the latter burning a mixt of kerosene and naphtha

Its length with booster is 9.53m, body diam 0.76m, wing span 2.90m, launch wt 3175kg, max speed Mach 2.5, and max range 112km. Both nuclear and HE warheads, with proximity fuze, are available with Talos missiles

The effectiveness of this missile was demonstrated in 1968, when Talos missiles launched from the nuclear-powered cruiser *Long Beach* destroyed two MiG fighters flying over North Vietnam, some 112km from the ship. Other US Navy cruisers continue to deploy Talos, and the designation *RIM-8H-ARM* given to one current version indicates that it carries an anti-radiation homing head for surface-to-surface use against enemy radars at sea or on land

Refs: 1) M.J.H. Taylor & J.W.R. Taylor, Eds, "Missiles of the World", Charles Scribner's Sons, NY (1976), 146 2) R.T. Pretty, Ed, "Jane's Weapon Systems-1977", Franklin Watts, NY (1976), 115

Tamping. The act of charging or tamping a charge into a hole with the aid of a tamping stick. Sometimes used loosely for "stemming" (qv)

Refs: 1) C.E. Gregory, "Explosives for North American Engineers", Trans Tech Publications, Cleveland (1973), 136, 196, 240 & 265 2) C.E. Gregory, "Explosives for Australasian Engineers", 3rd Ed, Univ of Queensland Press (1977), 73, 80, 81 & 156

Tanoyaku (Jap). Mixts of RDX, TNT and Tetryl. See also under "Shouyaku or Tanayaku" in Vol 7, J51-R to J52-L

Ref: R. Meyer, "Explosives", Verlag Chemie, NY (1977), 353

Tantalum. Ta; at w 180.9479; at no 73; valence 5, also 4, 3, 2; two naturally occurring isotopes:

181 (99.9877%), 180 (0.0123% with a half life of $> 10^{12}$ yrs); artificial radioactive isotopes: 172-179, 182-186; grey, v hard, malleable, ductile metal; mp 2996°; bp 5429°; d 16.69g/cc. Sol in fused alkalis, HF and sulfuric acids; not sol in w. CA Registry no [7440-25-7]. Occurs almost invariably with niobium; less abundant than niobium. Found in the minerals columbite, tantalite and microlite. Prepn is from TaK-fluoride by heating in an electric furnace, by Na redn, or by fused salt electrolysis. Vac sintering converts the powdered metal to a massive metal. Foot-long crystals can be grown by arc-fusion

Ellern (Ref 2) reports that glassless pyrot time delay compns incorporating powdered Ta have been developed (see Table 1) which have a burning rate range of from about 0.1 to 20sec/inch, and can be functioned at temps of from -90° to $> 200^{\circ}\text{F}$

Table 1
Tantalum Gasless Delay Compositions
(Ref 2, p 284)

	85	86
Tantalum, %	29	50
Ba chromate, %	71	50

The max safe tolerance level in air for powdered Ta is 5mg/m³ (Ref 3)

Refs: 1) Gmelin, Syst Nr 50, Teil A, Lief 1 (1969) 2) Ellern, "Modern Pyrotechnics . . .", Chemical, NY (1961), 145 & 284 3) Sax (1968), 1134 4) Merck (1976), 1173 (no 8831) 5) CondChemDict (1977), 837

Tapered Bore Gun (Conic Gun). As far back as the 1870's conic guns had been suggested and constructed for exptl purposes. Theory predicated that if the barrel was made with a gradually-decreasing caliber (and if the projectile was designed to adapt to the diminution) then, since the base area of the shot is reducing while the propelling gas pressure either remains constant or increases (depending on the cartridge design), then the unit pressure on the shot base will increase and the shot will be given greater velocity

The idea was first patented by Carl Puff in 1904 (BritP 8601), and the drawings show a projectile almost identical to those later developed in Ger. Puff, however, does not appear

to have pursued his ideas as far as a working gun, and the idea lay dormant until taken up by a Ger engineer named Gerlich in the 1920's. In cooperation with Halbe, a gunmaker, he developed a number of high-velocity sporting rifles with tapered bores and flanged projectiles, marketed in limited numbers during the 1930's under the name *Halger*, while at the same time attempting to interest various governments in the possible use of these weapons as high-velocity military rifles. He also worked briefly for both the US govt and the Brit army on taper-bore rifles, but neither felt that there was much virtue in the idea

By this time others in Ger were exploring the idea: Rheinmetall-Borsig, Krupp, Bochumer Verein and Polte-Werke all had exptl programs varying in degree of involvement. Rheinmetall-Borsig eventually became the most involved; the firm's Dr Werner Banck, who took charge of development in late 1939, continued to work on it thruout WWII and ultimately became one of the most knowledgeable men in the world on the subject of taper-bore guns

Two classes of weapon were eventually categorized: the *taper bore*, in which the barrel is tapered evenly from breech to muzzle, and the *squeeze bore*, in which the barrel was parallel for some distance and then tapered sharply to effect the "squeezing" of the projectile, finishing as a parallel bore of smaller dimension. An alternative design of squeeze bore was one in which a tapered extension was placed on the muzzle of an otherwise conventional gun [see also "Salvo Squeezebore (SSB)" in this Vol]. The projectiles used with these two classes were much the same in design, though experience showed that the taper bore shot had to be somewhat stronger in construction than the squeeze bore models owing to the different times thruout which the shells underwent stress in compression

Towards the end of WWII the taper bore concept was gradually discarded in favor of the squeeze bore designs, since these were a good deal easier to manufacture. Making a tapered and rifled gun barrel was no easy task, even with sophisticated machine tools, whereas production of a smoothbore "squeeze" extension to fit the muzzle of an otherwise standard gun was much less exacting and less wasteful of time and

material. Weapons as large as 24cm caliber were fitted with such extensions (in this case reducing to 21cm) and were fired quite successfully

The only Ger active-service use of the taper or squeeze systems was in the anti-tank class, where three weapons (2.8cm/2.1cm, 4.2cm/2.8cm and 7.5cm/5.0cm) entered service. In the anti-aircraft field, while the velocity increases gave promise of considerably improved performance and where many exptl weapons were built and fired, no guns were ready for service before the war ended. There was a rule of thumb that said a squeeze bore adapter could be expected to increase velocity and max range by about a third. Velocities of as much as 1400 mps (4595fps) had been achieved but it was felt that, bearing in mind wear-rates and dispersion at extreme ranges, service velocities of from 1150 to 1200mps (3775 to 3935fps) might be consistently reached

Refs: 1) Anon, *EngrgDesHndbk*, "Elements of Armament Engineering—Part Three—Weapon Systems and Components", **AMCP 706-108** (1963), A10 to A11 2) I.V. Hogg, "German Artillery of World War Two", Hippocrene Books, NY (1975), 9 & 187-212

Tapered Bore (Folding Skirt) Projectiles. This type of projectile is fired thru a tapered bore (see preceding article) which may either be built into the gun, or which may be added to a standard gun by means of a special muzzle attachment. The taper serves to swage down the flanged skirts which extend from the main body of the projectile as a jacket. As a result, the emergent caliber is much less than the original diameter. In this way, the accelerating pressure of the propnt gases acts on a large area in the gun bore, while a small (emergent) area is presented to the resisting pressure caused by air resistance in flight

This type of projectile has, therefore, the advantage of good exterior ballistics from the standpoint of ballistic coefficient. However, the swaged down skirts make imperfect contact with the projectile body, thus creating generating points for retarding shock waves at high velocities

There are two other serious disadvantages of

the folding skirt type. The taper prohibits the use of standard ammo in tapered bore guns and also increases tremendously the time and costs of production of both gun and ammo. In addition, the gun tube is short lived

See also under "Salvo Squeezebore (SSB)" in this Vol

Refs: 1) Anon, *EngrgDesHndbok*, "Elements of Armament Engineering—Part Two—Ballistics", **AMCP 706-107** (1963), p 10–23 2) I.V. Hogg, "German Artillery of World War Two", Hippocrene Books, NY (1975), 264–65

Target Charge. Propelling charge intended to produce a velocity less than normal, and considered to be suitable for target practice purposes. The term is also sometimes used as an identifying designation when more than one type of propelling charge is available for a weapon

Ref: Anon, *OrdnTechTerm* (1962), 67-R

Tarnovski Explosives. Blasting expls patented in Fr in 1913 (FrP 465082) and claimed to be more powerful than some NG Dynamites. A typical formulation consisted of Amm perchlorate 67, TNB 13, Al powder 10 and wood-meal 10%. As these expls developed HCl gas, they could be used only in open blasting operations. If, however, part of the perchlorate was replaced by alkali or alkaline earth nitrates, the expls would be suitable for use in mines

Ref: Colver (1938), 739

Tars, Nitrated. See under "Coal Tar and Coal Tar Pitch" in Vol 3, C379-R to C380-R

Addnl Information: Silberrad (Refs 1 & 4) nitrated neutral coal tar fractions (bp 200–350°) and called the product obtained "Nitrol". He claimed that it was a HE, suitable for use in expl mixts. Nitrol plasticized or dissolved such aromatic nitrocompds as TNT, TNB, etc, and was suitable for the manuf of plastic safety expls of great durability and power. A typical formulation contained Nitrol 10, a highly nitrated benzene hydrocarbon 20, collodion cotton 0.5, and AN 69.5p

J.R. Mardick (Refs 2 & 3) described the nitration of coal tars and claimed that the products

obtained could be used as 1) substitutes for S and C in making expls similar to BlkPdr, by mixing with nitrates or perchlorates, or added to proplnts to render them more stable and reduce their cost, or generally used in many expls as a substitute for TNT; and 2) an ingredient of Dynamite

More recently, Matter (Ref 5) patented the use of tar distillates mixed with oxygen carriers such as inorganic nitrates, chlorates, perchlorates, or mixts thereof, to form a plastic Dynamite
Refs: 1) O. Silberrad, *BritP* 13861 (1911), *USP* 1092758 (1912) & *CA* 7, 258 (1913) 2) J.R. Mardick, *USP* 1225347 (1917) & *CA* 11, 2154 (1917) 3) *Ibid*, *USP* 1258587 (1918) & *CA* 12, 1421 (1918) 4) Colver (1938), 259–61 5) O. Matter, *SwissP* 220755 (1942) & *CA* 42, 6538 (1948)

Tartaglia, Niccolo (1501–1557). Italian mathematician and ballistcian. His first published work, in 1537, "Nuova Scienza", dealt with the theory of gunnery. It gives evidence of more practical than theoretical knowledge, but was one of the first applications of mathematics to gunnery. He dealt with artillery and fortification again in his "Questi et Invenzioni Diverse" (1546), dedicated to Henry VIII of England. Tartaglia's greatest publication, his "Trattato Generale" (1556), was perhaps the best mathematical compilation of the time. It covered arithmetic, mensuration, geometry, and algebra, and was a valuable synthesis of the practical and commercial mathematics of his century

Refs: 1) V. Montojo, *MAF* 13, 790 (1934) 2) T.I. Williams, "A Biographical Dictionary of Scientists", 2nd Ed, J. Wiley & Sons, NY (1974), 504

Tartar (RIM-24). A US medium-range, supersonic surface-to-air shipboard guided missile system. It provides primary air defense for US Navy destroyers and destroyer escorts and secondary air defense for cruisers. The missile booster and sustainer rockets are combined in a single solid-proplnt motor, thus facilitating installation on smaller ships

Tartar employs a fully automatic magazine handling and loading system. Targets are de-

signed to the system in two or three co-ordinates by radar. The tracker/illuminator radars automatically follows the targets and a computer provides missile launcher pointing orders. Guidance is semi-active homing. The missile carries a HE warhead with impact and proximity fuzes

The rocket motor has two levels of thrust to achieve rapid acceleration. The guidance system computes a collision course, then steers to intercept by means of four hydraulically actuated tail fins

Range, more than 16km; speed, Mach 2; length, 4.6m; diameter, 30cm; wt, 680kg

Tartar is being replaced by the RIM-66A medium-range Standard Missile, which resembles it in appearance

Refs: 1) M.J.H. Taylor & J.W.R. Taylor, "Missiles of the World", Charles Scribner's Sons, NY (1976), 146-47 2) R.T. Pretty, Ed, "Jane's Weapon Systems-1977", Franklin Watts, NY (1976), 115

Tartaric Acid and Derivatives

d-Tartaric Acid [Ordinary tartaric acid, Natural tartaric acid, Dextrotartaric acid, L-2,3-Dihydroxybutanedioic acid, d- α,β -Dihydroxysuccinic acid, Weinsäure or Weinsteinssäure (Ger)]. $\text{HO}_2\text{C}.\text{CH}(\text{OH}).\text{CH}(\text{OH}).\text{CO}_2\text{H}$; mw 150.09; monoclinic sphenoidal prisms; mp 168-70°; d 1.75g/cc at 20/4°; $[\alpha]_D^{20} + 12.0^\circ$ (C=2 in w); RI 1.4955. V sol in ethanol and w; sol in acet; v sl sol in eth. CA Registry No [87-69-4].

Found in nature as the Ca, K or Mg salt of a fruit acid. Comm'l prepn consists of conversion of the acid K tartrate obtd during wine making to Ca tartrate which is then hydrolyzed to tartaric acid and Ca sulfate. The acid has an autoign temp of 802°F and a flash pt of 410°F

It was suggested by Krauz and Majrich (Ref 2) that tartaric acid be used as a stabilizer for NC in smokeless powders since it is easily nitrated to the dinitro stage when exposed to nitrous fumes. However, its stabilizing property is surpassed by acids such as trihydroxyglutaric, mucic and succinic

Refs: 1) Beil 3, 481, (169), [308] & [994] 2) C. Krauz & A. Majrich, ChemObzr 8, 213-14; 233-37 (1933) & CA 28, 4907 (1934) 3) Sax

(1968), 1135 4) Merck (1976), 1174-75 (No 8845) 5) ChemRubHdb (1978), C-509

d-Tartaric Acid Diazide [or d-Weinsäurediazid (Ger)]. $\text{N}_3.\text{CO}.\text{CH}(\text{OH}).\text{CH}(\text{OH}).\text{CO}.\text{N}_3$; mw 152.10; N 55.27%; OB to CO_2 -63.12%; cryst; mp 66° (decompn). V sol in acet, ethanol and w; sol in eth; insol in chl and ligr. Prepn is by reacting d-tartaric acid dihydrazide with Na nitrite in w. The diazide deflagrates strongly on heating

Refs: 1) Beil 3, (180) 2) J. Curtius, JPrakt.-Chem 95, [2], 220 (1895)

Lg-Tartaric Acid Dinitrate (Nitrotartaric acid or Dinitrotartaric acid. $\text{HO}_2\text{C}.\text{CH}(\text{O}.\text{NO}_2).\text{CH}(\text{O}.\text{NO}_2).\text{CO}_2\text{H}$; mw 192.06; N 14.59%; OB to CO_2 0%; v unstable and hydr silk-like ndles. V sol in ethanol and eth; insol in benz and chl. Prepn is by treating d-tartaric acid with mixed concd nitric-sulfuric acid. The dinitrate is considered "too sensitive" for use in a mil expl by Ref 4. It decomps violently well below 100° when moist. However, dry Nitrotartaric acid is stable at ca 140° (Ref 3)

Refs: 1) Beil 3, 509, (176), [320] & [1018] 2) V. Dessaignes, Ann 82, 326 (1852) 3) A. Lachman, JACS 43, 577 (1921) & CA 15, 1530 (1921) 4) A.H. Blatt & F.C. Whitmore, OSRD 1085 (1942), 78

N,N-Dinitro Dimethyldiaminodinitrotartaric Acid. $\text{CH}_3.\text{N}(\text{NO}_2).\text{CO}.\text{C}(\text{O}.\text{NO}_2).\text{C}(\text{O}.\text{NO}_2).\text{CO}.\text{N}(\text{NO}_2).\text{CH}_3$; mw 276.06; N 30.45%; OB to CO_2 -17.39%; cryst; mp 114°. Sol in ethanol, hot eth, benz, chl, CCl_4 . Prepn is by dissolving N,N'-dimethyldiaminotartaric acid in nitric acid maintained at -5° to 0°, and then pouring the resulting soln into acet anhydr, also maintained at a temp of -5° to 0°. The prod is crystd by drowning the reaction mixt in ice w. The dinitrate has a deflagration temp of 117° when 0.1g is heated at a rate of 20°/min, a 50% impact sensy point of 9cm using a 2-kg wt, and a 10% impact sensy point at 4cm, also using a 2-kg wt. Urbański considers the dinitrate to be a very powerful expl, sensitive to shock but stable to heat

Refs: 1) Beil - not found 2) T. Urbański, RocznikiChemii 16, 334-38 (1936); also Ibid, SS 32, 20 (1937) & CA 31, 1770 (1937)

TATB (TATNB or 1,3,5-Triamino-2,4,6-Trinitrobenzene).

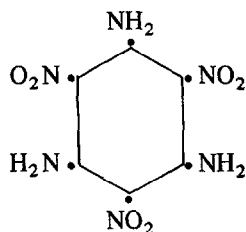

$C_6H_6N_6O_6$; mw 258.18; N 32.56%; OB to CO_2 -55.78%; lt yel triclinic cryst; mp, not fixed, however, instantaneous hot-bar decompn temp is $450-51^\circ$ (thermal decompn is rapid above 320°); d 1.93 ± 0.0 /g/cc (cryst observed), 1.937 g/cc (calcd from X-ray data). > 20% wt/vol sol in "superacids" such as concd sulfuric acid, chlorosulfonic acid, fluorosulfonic acid and trifluoromethane sulfonic acid; $\sim 0.1\%$ wt/vol sol in solvents such as aniline, dimethylformamide, phenylhydrazine, ethylenediamine, gammabutyrolactone and NB; insol in benz, chl, ethanol, eth, and gl acetic acid (Refs 6, 9, 12, 34, 56 and 66). CA Registry No [3058-38-6]

Historical. TATB was first prepd in 1888 by Jackson and Wing (Ref 2), who also determined its solubility characteristics. B. Flürscheim and E. Holmes (Ref 6) prepd TATB from benz-free pentanitroaniline by gradually adding it to 10% aq ammonia. After boiling, an or-yel powdr melting above 300° was obtd. This prod corresponded to that described by Jackson and Wing. These authors, as well as Palmer (Ref 2a), attempted to reduce TATB to hexa-aminobenzene. Either decompn occurred or a hydrochloride of penta-aminobenzene was formed. Flürscheim and Holmes succeeded in reducing TATB with phenylhydrazine by heating them together up to 200° (Ref 6)

In the 1950's the US Naval Ordn Lab recognized TATB as a useful heat-resistant expl. Successful small-scale prepn was achieved by saturation of abs ethanol with ammonia and adding 1,3,5-tribromo-2,4,6-trinitrobenzene. The stoppered reaction flask was then allowed to stand at RT for a day. Then, addnl ammonia was bubbled into the mixt, which was refluxed for 30 mins., filtered hot and the insol prod collected on a Buchner funnel. The impure prod was then w-washed, ethanol-washed, dried and

recrystd from NB

As a result of attempts to find a modification of various amination procedures which would produce high yields of a pure product, Benziger and Rohwer (Refs 3, 6, 15, 19, 37 and 55) evolved the following "two step" procedure presented next:

1) Nitration of s-trichlorobenzene (1,3,5-TCB) to 1,3,5-trichloro-2,4,6-trinitrobenzene (TCTNB)

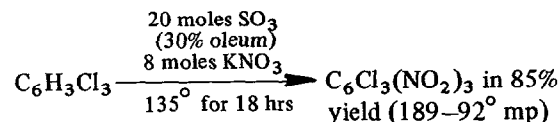

2) Amination of the TCTNB to yield TATB

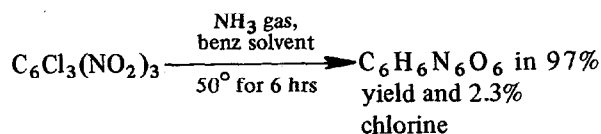

Benziger (Ref 60) reports in his patent that the problem with the above procedure is the prodn of amm chloride as a contaminating by-product. The refined patented process renders the amm chloride formed semideliquescent, allowing for its removal in aq soln by using toluene contg $\sim 2.5\%$ w as the solvent for the gaseous ammonia. Attempts to reduce chlorine contamination of TATB are reported by Estes (Ref 62). He concludes that "... probably the best methods of reducing the halogen content of TATB found thus far are by recrystallization and ... emulsion processing. Emulsion amination of TCTNB in ammonium hydroxide appears to reduce the inorganic chloride content by 1 or 2 orders of magnitude in laboratory scale experiments ...". Estes also reports (Ref 78) on an alternative starting material to TCB (suggested because of environmental concerns); 1,3,5-trichloro-2-nitrosobenzene

Preparation.

1) **Laboratory.** The preferred lab prepn consists of the nitration of s-trichlorobenzene with a mixt of nitric acid and oleum at a temp of 150° for 3 hrs. A toluene soln of the TCTNB produced by the nitration is then aminated to yield TATB

2) **Plant.** A) The preferred plant prepn to produce a particle size greater than 20 microns in 96% of the yield, suitable for PBXs and

normal expl compounding methods, is that of Benziger and Rohwer (Ref 15, pp 13–17) modified by the patented procedure of Benziger (Ref 60), viz:

Equipment:

1. A 10-gallon, glass-lined Pfaudler reactor capable of operation over a range of 20–150°C and pressures of 70mm Hg absolute to 100 psig; agitation provided by an anchor type blade at speeds of 20 to 200 rpm
2. A glass-lined, concentric tube reflux condenser, integral with the reactor
3. A 50-gallon, stainless steel reactor with agitator used in ice quenching of the nitration mixt
4. Two 60-gallon, stainless receivers used in filtrate storage and recovery
5. A stainless steel, 11" x 11" x 2" plate and frame filter press, closed delivery washing type

Nitration Step:

Materials

Mole ratio: 1/6.6/15.6 – TCB/NaNO₃/SO₃
(30% oleum)
5.5 lbs TCB, mp 63–64°, Eastern Chem Corp
17.0 lbs NaNO₃, AR, granular
126.0 lbs oleum (30%)

Procedure

- a) The oleum is charged to the glass-lined reactor, and the Na nitrate is then added at a slow rate with full agitation. The reaction is quite exothermic, and jacket cooling is used to keep the temp at 60–70°. When the entire amt of Na nitrate has been added and the exotherm peak has passed, the kettle contents are brought to a temp of 100°
- b) The TCB is then charged to the reactor, and steam is applied to the jacket to bring the temp quickly to 145–55°. The reactor contents are maintained at this temp for a period of four hours. The small amts of gases generated during the nitration are vented thru the reflux condenser
- c) At the end of the four-hour reaction period, the contents are cooled to 40° and discharged into the 50-gal stainless steel reactor which contains approx 250 lbs of crushed ice. Full agitation is used during this quench step, and the nitrous fumes are removed using a w-sealed vac pump. The TCTNB product ppts in the form of heavy white crystals. With the stated quantity of ice, the temp during dilution does not exceed

40°, and hydrolysis of the prod does not occur
d) The quenched reaction mixt is then pumped thru the plate and frame press which discharges into a 60-gal holding tank. Dynel cloth is used as the filtering medium. Only two frames (0.24 cu ft) are needed for the amount of cake produced. The cake is washed with several 20-gal quantities of w, each followed with an air blow. This is continued until the wash w pH is 6–7. The cake is dried in open trays in a forced-draft oven at 60° for 16 hrs

Amination Step:

Materials

Mole ratio: 1/7.1 – TCTNB/NH₃
6 lbs TCTNB
60 lbs toluene, tech grade
1.5 lbs water
2.3 lbs NH₃, anhyd, refrigeration grade (includes leakage and blowdown)
Product yield: 4.4 lbs

Procedure

- a) The TCTNB is dissolved in the toluene and the soln is clarified by filtration using Celite filter aid before transfer to the 10-gal reactor
- b) At this point Benziger (Ref 60) recommends that elimination of 67% of the contaminating amm chloride by-product can be accomplished by the addition of 1.5 lbs of w. The reactor system is then sealed and heating is continued until the contents are at 145°
- c) As the amination step is moderately exothermic, the jacket steam is turned off at this time. Ammonia gas is then added to the reactor gas phase thru an opening on the top of the kettle. It is metered thru a rotameter at a rate of about 0.8 lb/hr. When the NH₃ overpressure reaches about 5 psi, the reactor system is purged of residual air by venting thru the reflux condenser. The system is then resealed, and the reaction is continued for a total of approx three hours. Moderate agitation is used during this period. In the course of the reaction, conducted at 150°, the system press will remain at 35–40 psig for most of the three-hour reaction period. This represents an NH₃ partial press of about 5–10 psi. As the reaction progresses, a small amount of jacket heating may be necessary to maintain the 150° temp. The termination of the amination reaction is marked by a sharp rise in system press to about 60 psig
- d) After the press rise is noted, the NH₃ flow is

shut off and the system is cooled to about 60°. The system is vented, and approx ten gals of w is added to the reaction mixt with good agitation. The TATB prod is recovered by filtration using the plate and frame press, equipped with cotton cloths backed with filter paper. One frame (0.12 cu ft) is sufficient for the amount of product produced. The cake is washed three times with 20-gal portions of w, interspersed with air blows. This is sufficient to remove by-product NH₄Cl. To dry the cake and remove volatile impurities, the cake is steamed for about ten minutes and air-blown before removal from the press. The cake is then dried in open trays in a forced-draft oven at 100° for 16 hours

Data on a typical pilot plant product are as follows:

Yield (based on crude TCTNB) – 89.0%

Impurity content (chlorine) – <0.6% (with the

Benziger modification about 0.2%)

Particle size – 4% below 20 μ

Crystal density (sink-float) – 1.93g/cc

Analysis –	Found	Calculated
C	27.14	27.91
N	32.53	32.56
H	2.79	2.34
Cl	0.59	–

B) The preferred process for plant scale prodn of a fine particle size TATB, ie, $\bar{X} = 82 \pm 5\%$ passing thru a 20 micron sieve, is that of Quinlin and Locke (Ref 64). The material produced is suitable for booster pellets. The procedure is summarized as follows:

All the amination reactions are conducted in a 100-gal stainless steel reactor heated with 75 psi steam to the jacket. The reactor is fitted with an ammonia inlet, a vent tube for azeotroping w from the system and a thermowell

The TCTNB is first dissolved in toluene in a feed vessel and passed thru a 1.5 μ m in-line filter during transfer to the reactor. The soln is then heated to 140° and the w azeotroped from the system. The ullage is then backfilled with ammonia and the temp brought to 150°. The

Table 1
Amination Results

Batch No	Yield TATB (kg)	Time (hrs)	Total Chlorine, % ^a	Particle Size ^b	
				<20 μ m (%)	<44 μ m (%)
7076	18.2	6.25	0.44	87.5	99.0
7080	19.1	6.25	1.05 ^c	77.9	96.5
7084	18.2	5.75	0.47	88.0	98.1
7087	15.4	6.00	0.40	77.1	98.2
7088	16.8	6.50	0.52	79.2	97.4
7094	17.2	5.75	0.60	85.2	99.7
7242	16.8	6.75	0.45	88.8	98.3
7265	17.0	8.00	0.50	80.0	97.0
7270	17.7	6.50	0.37	85.7	97.7
7271	17.7	6.00	0.44	75.2	89.7
Mean			0.5	82.0	97.0
Standard Deviation			0.07	5.1	3.2

a—by decompn in a Parr bomb calorimeter and detg the chloride liberated by titration with Ag nitrate

b—by wet sieving thru a stack of electroform sieves

c—omitted from calculation of average

Note: All batches were run using 26.3 kg TCTNB in 312-liter toluene at 154° and 55 rpm. Concn was at 0.084 kg/l

reaction time varies between 6 and 8 hours with completion indicated by a drop in ammonia flow as measured by the mass flow meter, an increase in system press approaching the 60 psig of the ammonia regulator and a decrease in the heat generated as indicated by the requirement of more steam to the reactor jacket

Product isolation involves cooling the reaction mixt to 100°, adding 40ℓ of w and vigorously stirring for 0.5 hours. The warm mixt is isolated in a plate and frame filter press, washed with 85° w for 1 hr and steamed for 1 hr. The product is then dried at 115° for a min of 16 hrs prior to sampling and packaging

Table 1 gives the yield, conditions and analysis for 10 TATB batches thus prepd

Properties. The structure of TATB, as illustrated in Fig 1, contains many unusual features. Some of these are the extremely long C-C bonds in the benzene ring, the very short C-N (amino)

bonds, and the six furcated hydrogen bonds. Evidence of a strong intermolecular interaction (hydrogen bond) in TATB is indicated by the lack of an observable mp, and low solubility in all solvents except concd sulfuric acid and the like. The intermolecular network results in a graphite-like lattice structure with the resulting properties of lubricity and intercalaction. The unit cell is triclinic (X-ray data), P1, $a=9.010$, $b=9.028$, $c=6.812\text{\AA}$, and $\alpha=108.59^\circ$, $\beta=91.82^\circ$, $\gamma=119.97^\circ$; with two molecules/cell (Ref 12)

Kolb and Rizzo (Refs 75 & 84) studied the expansion of TATB on a molecular level by means of X-ray crystallography. Continuous monitoring of the cell constants of TATB between 214° and 377°K allowed for the calcn of a volume change of +5.1% for this molecular system. Expansion of the pure material is almost exclusively a function of a 4% linear increase in the c axis (the perpendicular distance between sheets of hydrogen-bonded TATB).

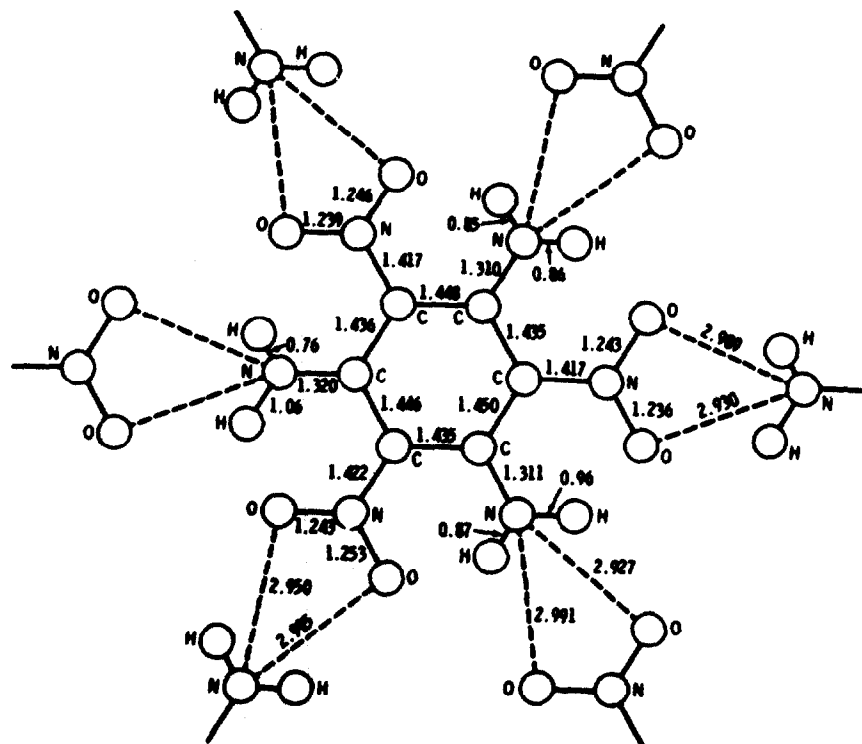

Fig 1 Configuration of the TATB molecule within the normal lattice according to Cady and Larson. Bond lengths are given in Å and the dashed lines represent hydrogen bonds between the basic molecule and its nearest neighbors (Ref 36)

Table 2
Properties of TATB

Property		Value				Ref			
Activation Energy, E (kcal/mole)		59.9				34			
Autoignition point, °C		320-25				14			
Booster Sensitivity		<u>30-10 log (test gap/ref gap)</u>		<u>Lucite gap (mils)</u>		8			
	at 93% TMD	10.1		98					
	at 95% TMD	11.1		78					
Brisance by Sand Test, gm		42.9				6			
Cook-Off Test	<u>Round No</u>	<u>Sample Size, g</u>	<u>Min Heating Time, mins</u>	<u>Deton Temp, °C</u>		6			
	1	29.2	10.2	355					
	2	29.2	10.0	346					
	3	29.2	9.5	352					
Critical Temp (for a 0.66mm thick bare slab), °C		Calcd 334 Exptl 331 Gilding Metal 312 Al 331 (332)				34			
In cells of different materials at d 1.84g/cc °C		0.67				50a			
Cylinder Test at d 1.863g/cc (PBX 9404 Ref = 1.00)		0.67				50a			
Detonation Parameters	<u>Chapman-Jouguet Pressure, Energy, and Isentropic Exponent from Water Shock Measurements</u>							11	
	d or ρ (g/cm ³)	Deton Vel, D(m/sec)	U_{H_2O} (m/sec)	u_{H_2O} (m/sec)	P_{H_2O} (at HE-H ₂ O interface) (kb)	Deton Press, P_{CJ} (kb) ^a	Isentropic Exponent, k	Deton Energy, Q (cal/g)	
	1.80	7658	6071	2685	163.0	259.4	3.07	829	
1.50	6555	5519	2303	126.9	174.6	2.71	808		
a - calcd at ρ_C as being 29.3 GPa (from Ref 25)						50a			
C-J Pressure at ρ_C , (calcd) kbar						50a			
C-J Pressure, Plate Dent Value at 1.870g/cc, kbar						50a			
Deton Vel at ρ_C , (calcd) m/sec						50a			
Deton Vel at d 1.857g/cc, m/sec						50a			

(continued)

Table 2 – Properties of TATB (continuation)

Property	Value					Ref
Detonation Velocity						11
	Charge No	Diameter (cm)	Length (cm)	Confinement	Density (g/cm ³)	Detonation Velocity (m/sec)
	1*	Conical	0.64	None	1.880	–
		0.64	1.27	None	1.881	–
	(Boostered by 75/25 Cyclotol)	1.27	1.32	None	1.874	7610
		1.27	1.35	None	1.879	7610
		1.27	1.35	None	1.880	7610
		1.27	1.32	None	1.878	7614
		2.54	2.57	None	1.882	7772
		2.54	2.57	None	1.875	7772
	2**	Conical		None	1.864	7650
		1.27	2.54	None	1.863	7650
	(Boostered by Tetryl)	2.54	2.54	None	1.860	7745
		2.54	2.54	None	1.864	7745
		5.08	5.08	None	1.862	7745
		5.08	5.08	None	1.864	7745
	3	5.08	5.08	Glass	1.802	7658
	4	4.45	15.24	Glass	1.508	6555
		Cylindrical				
	—***	1.27	–	Yes	1.80	7500
	–	–	–	None	1.290	5380
	–	–	–	None	1.345	5628
	–	–	–	None	1.675	6550
	–	–	–	None	1.675	6575
	–	–	–	None	1.882	7035
	–	–	–	None	1.835	7220

* Tapered to 0.31cm from 0.64cm over 0.64cm length
 Detonation did not propagate into 0.64-cm diam section

** Tapered to 0.64-cm diam from 1.27-cm diam over 1.9-cm length

*** Confined—pressed at 50000psi

(continued)

Table 2 – Properties of TATB (continuation)

<u>Property</u>	<u>Value</u>	<u>Ref</u>
Electrostatic Sensitivity; 50% pt, Joules	1.83–6.3	14
Explosion Temp in 5 secs, °C	520	6
Failure Diameter, cm	1.3	8
Friction Sensitivity at 440kg-cm	10/10–no fires	14
Friction Test (Sliding Rod)	No Reaction	50a
Gap Test, Large Scale, mm	~ 14.73 (Comp B-3 is 50.29)	57
Gap Test, Small Scale, mils of polymethylmethacrylate required at the 50% pt for TATB, d 1.60g/cc (deton with 50000 bars explosive shock input press)	150	20
Gap Test, Small Scale (12.7mm) Donor: SE-1 detonator plus a PBX 9407 booster		31
	<u>d, g/cc</u>	<u>G₅₀ point (Brass Thickness, mm-inches)</u>
	1.60	2.16–0.085
	1.70	1.60–0.063
	1.80	1.14–0.045
	1.85	0.58–0.023
	1.88	0.25–0.010
Heat Capacity	$C_p(T^\circ) = 0.215 + 1.324 \times 10^{-3}T - 2 \times 10^{-6}T^2$	13
Heat Capacity at d 1.938g/cc, cal/°C-g	0.25	41
Heat of Combustion; $-\Delta H_c^\circ$, kcal/mole (in cal/g)	735.9 2850.34	41
Heat of Detonation at d 1.87g/cc; Q _d , cal/g	1018 ± 25	81
Heat of Explosion, ΔH_e° , cal/g	2831	6
Heat of Formation; ΔH_f° , kcal/mole	-33.46 -36.85 (separate value)	41 5, 8, 50a
Heat of Reaction during self-heating, cal/g	600	34

(continued)

Table 2 — Properties of TATB (continuation)

Property	Value	Ref				
Heat of Sublimation, cal/g	155.7	17				
Heat Test at 100°C	No loss, no expln in 100 hrs	6				
Impact Sensitivity: 1) PA app, 7mg sample, in inches	11	6				
2) 2.5 kg hammer, type 12 tools with and without grit, no deton (or reaction), cm	200	38				
3) 50% pt, cm	> 320	8, 11, 50a				
4) 50% pt, cm	≈ 800	57				
Wt energy, Joules	≈ 200	57				
Initiation Sensitivity, LA, g	0.30	6				
Impact to Detonation Threshold Velocity Measurements Obtained from the Transit of 0.25mm Thick Plastic Flying Plates Impacting TATB Pellets	TATB d, (g/cc)	Detonation Threshold Flyer Velocity, mm/μsec	42, 46			
		Flyer Diameter, mm		25	12.7	6.3
	1.85 (Blend 226)	3.1–3.5		—	4.2–4.5	
	1.80 (Blend 226)	2.8–3.0		—	4.2–4.8	
	1.70 (Blend 226)	2.4–2.6		—	3.4–3.8	
1.80 (Blend 317)	2.7–2.9	2.7–3.0	3.8–4.2			
Loading d at 50000psi, g/cc	1.80	6				
Loading d at 64000psi, g/cc	1.89	8				
Plate Push Value, ft/sec		8				
	at 98% TMD	3229				
	at 93% TMD	3124				
Radiation Effects: See "Radiation Induced Changes in Explosive Materials" in this Vol		24				
Gamma Radiation Effects						
Amt Co ⁶⁰ γ	d, g/cc	d, g/cc	Deton Vel,	Deton Press,	Expln	
R	Before	After	m/sec	kbar	Temp, °C	
Control	1.84	—	7510	260	403	
1.0 x 10 ⁷	1.84	1.84	7520	260	394	
9.0 x 10 ⁷	1.85	1.84	7525	261	370	
7.4 x 10 ⁸	1.82	1.81	7435	250	345	

(continued)

Table 2 – Properties of TATB (continuation)

<u>Property</u>	<u>Value</u>	<u>Ref</u>
Shipping Classification	Class A Expl	82
Shock Input to Cause Deton, kJ/m^2	9500	57
	(Comp B Ref) 1500	
Size Range, mean diameter in microns	15–25	14
Skid Test (LASL), Sandpaper target, d 1.88g/cc	Drop height off scale – no energy release	80
Solubility		56

1) Estimated Solubility of TATB in Various Solvents

<u>Solvent</u>	<u>Solubility, ppm</u>
Methanesulfonic acid	820
Hexamethylphosphortriamide	150
Ethanesulfonic acid	120
DMSO	70
Hexafluoroacetone sesquihydrate	68
N-methyl-2-pyrrolidinone	58
N,N-dimethylacetamide	33
DMF	27
Tetramethylurea	26
Dimethyl methylphosphonate	22
N,N-dimethylpropionamide	16
λ -butyrolactone, bis(dimethylamino)phosphochloridate, conc. nitric acid	14
3-methylsulfolane	13
Pyridine	12
Trimethylphosphate	11
Dimethylcyanamide, vinyl sulfone	8
Methyl dichlorophosphate	7
N-methylformamide	6
Methyl methanesulfonate	5
Trimethylphosphite	4

(continued)

Table 2 -- Properties of TATB (continuation)

<u>Property</u>	<u>Value</u>	<u>Ref</u>
Solubility (cont'n)	<u>Solvent</u>	<u>Solubility, ppm</u>
	Acetone, dimethyl carbamoyl chloride	3
	Acetonitrile, acetic anhydride, trifluoroacetic acid	2
	Acetic acid	1
	Hexamethyldisilazane, trifluoroacetic anhydride, hexafluorobenzene, pentafluoropyridine, perfluoro-2-butyltetrahydrofuran	< 1
2) Apparent Solubility of TATB in Basic Solvents		
	Tetramethylguanidine	485
	Bu ₄ NOH, 25% in methanol	390
	N,N,N',N'-tetramethylglycinamide	67
3) Super Solvents for TATB (solubility > 20% (w/v))		
	Concentrated sulfuric acid	
	Chlorosulfonic acid	
	Fluorosulfonic acid	
	Trifluoromethanesulfonic acid	
Spark Sensitivity, LASL Test, 0.010" Pb foil, Joules	11.29 at 25°; 6.75 at 150°	50a
Susan Test, at over 1.0km/sec impact velocity	No significant energy release	42, 46, 57
Temp at which TATB has a vap press of 10 ⁻⁷ Torr, °C	131.4	17
Temp at which TATB has a vap press of 10 ⁻⁵ Torr, °C	171.3	17
Temp-Time Heat Test Using Sample Cylinders 2.75" diam x 3.00" long, linear thermal input from 90°F to 500°F in 300 mins	Gaseous decompn occurs at about 600°F	22
Thermal Conductivity	DSC Measurements Made Between 26.5° to 40°C	
	<u>Batch No</u>	<u>d, g/cc</u>
		<u>λ x 10⁴ cal/cm-sec-°C</u>
	6064-16-01	1.8410
	6064-16-01	1.8576
	6072-16-01	1.8263
	6072-16-01	1.8273
	$\bar{X} = 1.83805$	$\bar{X} = 10.825$

T 43

(continued)

Table 2 – Properties of TATB (continuation)

<u>Property</u>	<u>Value</u>	<u>Ref</u>					
Thermal Decomposition	DSC exotherm at 330°, 350°	50a, 57					
Thermal Expansion Coefficients (214°K to 377°K)	$\alpha_a = 8.3 \times 10^{-6}/^{\circ}\text{K}$ $\alpha_b = 20.9 \times 10^{-6}/^{\circ}\text{K}$ $\alpha_c = 248 \times 10^{-6}/^{\circ}\text{K}$	75, 84					
	} linear						
	30.4 x 10 ⁻⁵ /°K volumetric						
Vacuum Stability, cc/g	At 100° for 40 hrs is 0.36	6					
	At 100° for 48 hrs is 0.0, 0.1, 0.12–0.29*	6, 8, 11, 14					
	At 200° for 48 hrs is 0.5	50a					
	At 220° for 48 hrs is 2.3	50a					
	At 260° for 1 hr is 0.7, 1.04–1.23, 1.85*	6, 8, 14					
	At 260° for 2 hrs is 0.8 (cc/g/hr)	11					
	At 280° for 1 hr is 2.0	8, 14					
	* separate values	11					
	At 280° for 2 hrs is 4.5 (cc/g/hr)	11					
Wedge Test Parameters							
	Initial Shock Velocity (m/sec)	Initial Particle Velocity (m/sec)	Initial Shock Pressure (kb)	Initial Compression (V/V ₀)	d or ρ ₀ (g/cm ³)	Deton Vel, D (Final) (m/sec)	
Shot No	Brass Thick (cm)						
TATB							
1	2.54	4612	976	83.7	0.788	1.862	Failed to
2	1.27	5140	1140	109.1	0.778	1.862	Detonate
3	1.27	5200	1129	109.3	0.783	1.863	
4*	1.27	5200	1129	106.0	0.783	1.800	6200

* 30-degree wedge, maximum thickness 3.10cm

Calculated from these data, the volume coefficient of thermal expansion for crystalline TATB is $30.4 \times 10^{-5}/^{\circ}\text{K}$

Using the configuration of the TATB molecule as shown in Fig 1, Pastine and Bernecker (Ref 36) derived an equation of state (P, v, E, T) for nonporous TATB from which they theorize that at constant vol the shock Hugoniot should remain close to the room temp isotherm up to a press of 200kbar. The reader is referred to the original paper which delineates the equation at length

TATB has excellent thermal stability. Exothermal decompn can be observed at about 330° in a differential thermal analysis (DTA) run at a heating rate of $10^{\circ}/\text{min}$. Arrhenius expression kinetic constants for the most observable condensed-phase decompn reaction are: $E=59.9\text{kcal/mole}$ and (the pre-exponential) $Z=3.18 \times 10^{19}\text{sec}^{-1}$ (Ref 34)

Under Oxygen deficient conditions, the formation of detonation product gases from TATB are as follows:

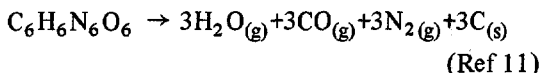

Other properties of TATB are presented in Table 2

Uses. Ambrosius and Rose (Refs 4 & 7) report that in spite of extensive development attempts, TATB could *not* be used as a base charge in a high temp-resistant electrically-initiated detonator simply because the expl could not be made to deton in the specified item. Stott (Ref 14) reports on initial development of castable formulations using silicone resins (approx 50 TATB/50 wt % resin) yielding compns with autoign temps of from 250° to 340° . Quong (Ref 26) advances an interesting concept for the use of TATB in nuclear weapons systems. His work evaluated a multi-component expl system consisting of a fuel (TATB) and an oxidizer (hydroxylammonium perchlorate). Here both fuel and oxidizer are individually non-expl (or extremely insensitive to impact), hence their use would minimize the danger of an unintentional expln as long as the components remain separated until used. He reports that the system appears feasible but that energy output is uniformly low. He concludes that higher energy systems can be achieved by using oxidizers with greater O_2

density. Hallam (Ref 43) suggests a process for the small-scale prepn of TATB/Kel-F (92.5/-7.5 wt %) PBX by the admixt of a TATB aq slurry with a solvent soln of Kel F. As the solvent is removed from the slurry at 75 to 80° under vac, the fine particles of TATB clump together to form granules. After drying at 80° , the granules are pressed at 120° and 138 MPa ($20,000\text{ psi}$) for shaping. Benziger (Ref 48) reports his patented procedure for making a pressed TATB expl using 10 wt % of a binder of chlorotrifluoroethylene-vinylidene fluoride polymer (Kel-F 800). The properties of this expl are presented as part 2 of Table 3

Ref 6 summarizes the major mil expl use of TATB as follows: “. . . special application in warheads of high speed guided missiles . . .”. Here, energy is sacrificed, but handling safety is gained because the main charge would remain inert under abnormal service environments of high-velocity impact and fire

Examples of both pressed and cast compns are presented in Tables 3 and 4

Compn PBX X-0219 has been acoustically characterized by Sutherland and Kennedy (Ref 35). The two parameters studied were the *viscoelastic* nature of the expl and its *geometric dispersion*. The former was found to be an important characteristic of the compn by a measurement process using a direct transmission ultrasonic technique to monitor acoustic phase velocity and acoustic attenuation as a function of temp at a constant frequency (-10 to 40° at 1.0 and 0.5MHz). This data is shown in Figs 2 and 3. Geometric dispersion was found to be an unimportant characteristic of the expl. The mechanism for this parameter was studied using an ultrasonic w-bath technique to measure the phase velocity as a frequency function at constant temp ($0.5-4.0\text{MHz}$ at 20°). The resulting data is shown in Fig 4

Routine *casting* procedures for TNT work well with a TATB/TNT formulation, “1)” of Table 4. The higher thermal conductivity of a TATB/TNT/Al formulation, “2)”, requires addnl side insulation of the molds and a crack inhibitor such as anthracene to produce intact charges free of fine cracks (Ref 28)

Pritchard (Refs 40 and 77) reports that after one to four months exposure at 120° materials such as 21-6-9 stainless steel, uranium, poly-

Table 3
Pressed Compositions

<u>Property</u>	<u>Value</u>		<u>Ref</u>
1) PBX-9502:			
Composition	TATB/Kel-F, 95/5 wt %; 95.2/4.8 vol %		59
Compressive Strength at d 1.892g/cc,	<u>MPa (psi)</u>	<u>Temp, °C</u>	59
	26.2 (3800)	-20	(see also Refs 32, 37 & 51 for data on similar compns)
	18.1 ± 1.38 (2620 ± 200)	21	
	10.3 (1500)	50	
Corner Turning	<u>mm</u>	<u>Temp, °C</u>	80
(distance from entrance surface to perpendicular emergence of deton wave from the cylindrical surface, where expl d is 1.892g/cc and expl contains 2.57% voids)	10.6	62	
	13.8	24	
	23.5	-53	
Deton Press, GPa	~29 at d 1.89g/cc		74
Deton Vel (Cylinder Test), m/sec	7589 at d 1.89g/cc		59
Deton Vel at Infinite Diam, m/sec	7700 at d 1.89g/cc		74
Drop Wt Sensy (12/12B Tools), cm	> 360		59
Energy Generation, cal/g-sec	3.2 x 10 ⁻¹ at 300°C		74
Failure Diam (d 1.89g/cc)	<u>mm</u>	<u>Temp, °C</u>	59
	10 ± 2	23 ± 2	
	11 ± 1	-55 ± 1	
Gap Test Data (1-5/8" diam and d 1.895g/cc), mm	22.33		82
Gap Test (25.5mm diam and d 1.895g/cc)	<u>mm Brass</u>	<u>Temp, °C</u>	59
	2.34	-78	
	3.78 ± 0.5	25	
	5.54	80	

(continued)

Table 3 — Pressed Compositions (continuation)

Property	Value					Ref
	Initial Press, GPa	Initial U_s , m/sec	U_p , m/sec	Time to Deton microsec	Dist to Deton mm	
Hugoniot and Sustained-Pulse Initiation Data (LASL) at d 1.896g/cc	10.05	4894	1083	2.893	15.38	80
	11.75	5401	1148	2.243	12.78	
	14.95	5552	1421	0.756	4.64	
Impact Vel for Initial Reaction, m/sec			> 500			74
Tensile Strength at d 1.89g/cc		MPa (psi)	Temp, °C			59
		5.75 ± 1.2 (834 ± 180)	21		(see also Refs 32, 37 & 51 for data on similar comps)	
2) <u>PBX-X0219</u>						
Composition	90 wt % TATB — 10 wt % Kel-F 800					48
Theoretical density (g/cm ³)	1.946					48
Typical pressed density (g/cm ³)	1.920					48
Detonation velocity, 1-5/8" diam (m/sec)	7,534					48
Failure diam (inches)	0.6–0.8					48
P_{CJ} , calc, $0.258 \rho D^2$ (kbar)	282					48
P_{CJ} , plate-dent comparison (kbar)	270					48
Cylinder-test comparison (PBX-9404=1.00)	0.68					48
Intra-Expl Shock Parameters Evolved on Detonation	Explosive	Impulse, $P^2\tau$ (kbar ² -μsec)	Peak Press, P (kbar) for 1-μsec pulse			48
	90 w% TATB–10 wt % Kel-F 800	23000	150			
	Composition B	700	26			
	PBX-9404	540	23			

(continued)

Table 3 – Pressed Compositions (continuation)

<u>Property</u>	<u>Value</u>				<u>Ref</u>
Mechanical Properties					48
	<u>Temperature (°F)</u>	<u>Yield Stress (psi)</u>	<u>Ultimate Stress (psi)</u>	<u>Modulus 10⁵ psi</u>	
Compressive	0	1750	5020	5.7	
	75	980	3140	5.2	
	120	600	1800	3.4	
	165	410	1240	1.9	
Tensile	0	420	1530	8.4	
	75	400	1020	4.5	
	120	210	710	1.7	
	165	150	450	1.9	
Shear	0	1880	2370	—	
	75	1450	1670	—	
	120	760	1020	—	
	165	520	520	—	

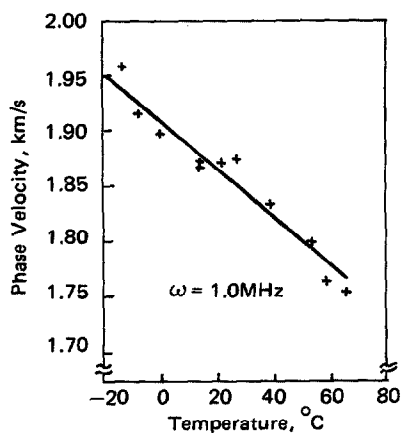

Fig 2 Phase Velocity Data at 1.0MHz for Formulation X-0219

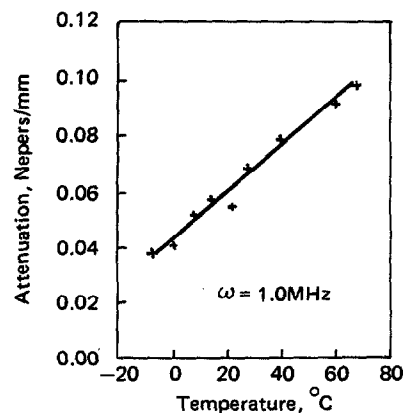

Fig 4 Attenuation Data at 1.0MHz for Formulation X-0219

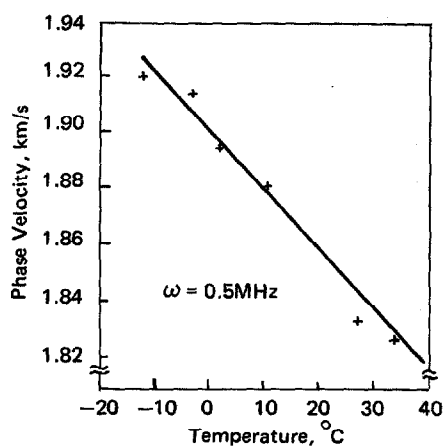

Fig 3 Phase Velocity Data at 0.5MHz for Formulation X-0219

carbonate, Al and Cu encased in polyimide film, Dupont LW-520 adhesive and Dow Corning 93-120 sealant exhibit both *compatibility* and *thermal* stability with TATB PBXs. However, the decomn of Estane 5702-F1 binder, he feels, has cast some doubt on the long-term stability of TATB/Estane compns. He concludes that TATB/Kel F and TATB/Viton A appear to be suitable for long-term use. Of concern in some applications is the small amount of w (<0.01%) present in the PBXs. No large-scale generation of NH_3 or NO_x was found

Table 5 is illustrative of the properties of a proplnt formulation containing TATB

Table 4
Castable Compositions

Property	Value	Ref
1) <u>TNT/TATB:</u>		
Composition	50/50 wt %	28 & 82
Chapman-Jouguet, P_{CJ} (GPa)	25.7 calcd at d 1.785g/cc	28
Deton Vel, m/sec	7461 calcd at d 1.785g/cc	28
Differential Thermal Analysis (DTA exotherm), °C	270	28
Failure Diam (cylindrical geometry), mm	41.3 (a go at d 1.76g/cc)	28
Fluidity (TMD g/cc, solid)	Pourable at d 1.783g/cc	28

(continued)

Table 4 – Castable Compositions (continuation)

Property	Value	Ref
Friction, Sliding Rod	No go	28
Gap Sensy (1-5/8" diam, d 1.759g/cc), mm	35.10	82
Impact Sensy (drop-wt using 12/12B Tools), cm	> 320	28
Plate-Dent Test in Steel, mm	6.35 on a d 1.76g/cc 41.3mm diam cylinder	28
Vac Stab, ml gas/g/48 hrs	At 120° is 0.1 At 150° is 0.7	28
2) <u>TNT/TATB/Al:</u>		
Composition	40/40/20 wt % TNT/TATB/Al	28 & 82
Chapman-Jouguet, P _{CJ} in GPa at d 1.913g/cc	25.1	28
Coefficient of Thermal Expansion, °C at d 1.895g/cc and temp range of 20–50°	4.4 x 10 ⁻⁵	28
Deton Vel, m/sec	Calcd at d 1.913g/cc is 7125 Exptl at d 1.900g/cc is 7111 with an unconfined diam of 50.8mm and $\sigma = 5.77$ m/sec	28
Differential Thermal Analysis (DTA exotherm), °C	275	28
Failure Diam (cylindrical geometry)	Go at test diam of 25.4mm and d 1.90g/cc	28
Fluidity, at TMD a solid	Quite fluid at d 1.913g/cc	28
Friction, Sliding Rod	No go	28
Gap Sensy (1-5/8" diam), mm	31.29 at d 1.893g/cc	82
Impact Sensy (drop-wt using 12/12B Tools), cm	> 320	28
Irreversible Cycling Growth Cycle between –54° and 74° in a 24-hr period with cycles repeated until growth ceases	Grows Linearly ~0.2% Before Stabilization	28
Mechanical Properties		
Compressive Strength, MPa (psi)	34.66 (5027) at d 1.895g/cc and 24°	28
Shear Strength, MPa (psi)	7.50 (591) at d 1.895g/cc and 24°	
Tensile Strength, MPa (psi)	5.10 (740) at d 1.895g/cc and 24°	
Plate-Dent Test, Steel, mm	At d 1.90g/cc and 41.3mm diam – 6.78 At d 1.90g/cc and 50.8mm diam – 8.15	28
Vac Stab, ml gas/g/48 hrs	At 120° is 0.0 At 150° is 0.3	82

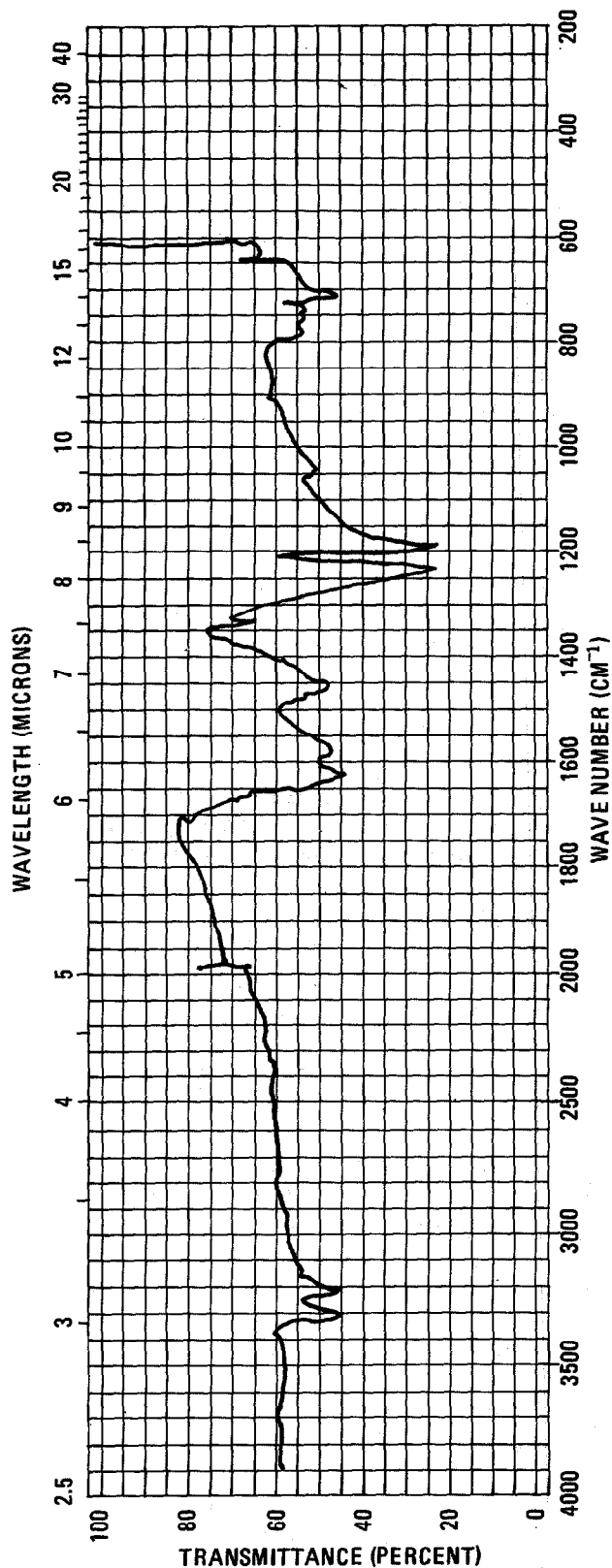

Fig 5 IR Scan of TATB

Analytical. The quantitative analysis of TATB by two methods is worthy of mention:

1) *Non-Aqueous Titrimetry.* A procedure for determining total amination is reported by MacDougall and Boyles (Ref 31b). The procedure includes a digestion of the TATB in 0.1N perchloric acid-acetic acid soln, followed by titrimetric analysis. An excess of basic K acid phthalate is added and then back-titrated with the perchloric-acetic acid soln to a crystal violet end pt. The method requires a sample contg 86mgs of TATB (~ 1 meq), and the digestion of the TATB requires 48 hrs. The authors estimate that 18 samples can be titrated in an 8-hr day. They conclude that the method is stoichiometric and that the relative std deviation is $\pm 0.1\%$ for 1 meq amounts of TATB. Also, an IR scan is reported and presented as Fig 5

2) *Spectrophotometric absorption.* Glover (Ref 9) reports a quantitative procedure for determining TATB above 90% concn by soln in concd sulfuric acid, followed by absorption measurements at both 325 and 272m μ using either a Beckman DU or Carey spectrophotometer:

$$\% \text{ TATB} = \frac{A(258)(100)}{C \times 10^4 (\text{g sample})}$$

where: A is the absorbance at 325m μ

C is the molar absorbancy index at 325m μ

g is approx 5mg

The author suggests that measurement of the sample absorbance at 272m μ also be made. The ratio of A_{325}/A_{272} should be between 1.93 and 1.97 for $\pm 1\%$ accuracy

Table 5
TKA — A High Temperature Propellant Composition Containing TATB

Property	Value	Ref
Composition, wt %	TATB 47	83 (See also Ref 10 for data on similar comps)
	KClO ₄ 41	
	Astrel 10	
	PbCrO ₄ 2	
DTA Exotherm, °C	275	83
Force, ft lbs/lb	265000	83
Grain Dimensions, Single Perforated, inches	0.110 OD x 0.035 ID x 0.130 long	83
Impact Sensy (Type 12 Tools), cm	83 (flame)	83
Relative Quickness (IMR-4350 = 100)	46	83
Service Requirement	175-200°/3 months	83
Spark Sensy, 3 mil of Pb, Joules	1.0	83
Vac Stab, ml gas/g/48 hrs	At 230° is 0.6	83

Refs: 1) Beil 13, 301, [147] & {556} 2) C.L. Jackson & J.F. Wing, AmerChemSocJ 9, 354 (1887); also see Ibid 10, 287 (1888) 2a) J. Palmer, Ibid 14, 378 (1892) 3) L.A. Kaplan & F. Taylor, Jr, "High Temperature Stable Explosives I. Process Development Study of 1,3,5-Triamino-2,4,6-Trinitrobenzene", NAVORD 6017 (1958) (Limited Dist; not used in this article) 4) C.D. Ambrosius & W.E. Rose, "Development of a High-Temperature Resistant, Electrically Initiated Detonator", Bimonthly Progr Rept No 5, Universal Match Corp, St Louis, Contract No N123 (62738) 18698A (1959) 5) D.V. Sickman, "Information on the Heat of Combustion of Some High Explosives", NOL Tech Note 1636 (1959) 6) Anon, OrdEngrgDesHbk, Expls Series, "Properties of Explosives of Military Interest (U)", Sect 2, ORDP 20-178 (1960), 84-87 7) Anon, "Research and Development to Obtain a High Temperature Resistant Electrically Initiated Detonator", 1st-12th Bi-monthly Prog Rept, Rept 3, Univ Match Corp, St Louis, Contract No N123 (62738) 18698A (1960), (1959), 14-20 8) M.F. Murphy & N.L. Coleburn, "A Preliminary Evaluation of TACOT, A New Heat Resistant Explosive (U)", NOLTR 61-155 (1961) 9) D.J. Glover, "Heat Resistant Explosives. XII. Quantitative Analysis of 1,3,5-Triamino-2,4,6-Trinitrobenzene", NOLTR-62-76 (1962) 10) W.O. Seals,

"Studies of Thermal Resistant Propellants for Power Actuated Devices", PATR 1182 (1963) (Limited Dist; not used in this article) 11) N.L. Coleburn & B.E. Drimmer, "The Explosive Properties of the Amino-Substituted, Symmetrical Trinitrobenzenes", NOLTR 63-81 (1963) 12) H.H. Cady & A.C. Larson, "The Crystal Structure of 1,3,5-Triamino-2,4,6-Trinitrobenzene", ActaCryst 18, 485-96 (1965) & CA 62, 11244 (1965) 13) R.N. Roger, Los Alamos Scientific Laboratory, private communication (1966) 14) B.A. Stott, "Castable Heat Resistant Explosive Compositions Capable of Withstanding 500°F and Higher", NWC-TP-4461 (1967), 7 15) T.M. Benziger & R.K. Rohiwer, "Pilot Plant Production of Triaminotrinitrobenzene (TATB)", LA-3632, Los Alamos Scientific Laboratory, Los Alamos, NM (1967) 16) Not used 17) J.M. Rosen & C. Dickinson, "Vapor Pressures and Heats Sublimation of Some High Melting Organic Explosives", NOLTR 69-67, US Naval Ordnance Laboratory, White Oak, MD 18) D. Price, "Burning Rates and Sensitivity Data for Explosive D, Comp A-3 and PBXW-106", NOLTR 70-137 (1970) 19) K.G. Shipp, "Properties of Selected Thermally Stable Explosives", NOLTR 70-95 (1970) 20) C.L. Scott, "The Sensitivity of Selected Conventional and Heat Resistant Explosives at Low Temperatures", NOLTR 70-36 (1970)

- 21) V.D. Gupta & B.L. Doopura, "Low Frequency Neutron Spectrum of 1,3,5-Triamino-2,4,6-Trinitrobenzene", *JMolPhys* **19** (4), 589-92 (1970) & CA **74**, 17650 (1971) 22) A.B. Donaldson & D.O. Lee, "Comparative Thermal Behavior of HMX and TATB Base Explosives", **SC-DR-720729**, Sandia Labs, Albuquerque (1972) 23) Not used 24) L. Avrami et al, "Radiation-Induced Changes in Explosive Materials", *PATR* **4602** (1973) & CA **81**, 93589 (1974) 25) P.E. Rouse, "Calorimetry", *WX-2 Monthly Progress Report, WX-2-MR-74-12*, Los Alamos Scientific Laboratory, Los Alamos, NM (1974) 26) R. Quong, "Nitrogen Component Explosive Systems. Feasibility Study", **UCID-16529**, LLL, Livermore (1974) & CA **82**, 113753 (1974) 27) M.L. Bernard et al, "Kinetic Theory of Condensed Explosive Detonation", *CR* **277** (16), 671-73 (1973) & CA **81**, 27804 (1974) 28) M. Urizar, "Progress Report-Hard Structure Munition Program-Oct 1973-Apr 1974" performed under SANL/Request 261-002 to Los Alamos Scientific Lab, Los Alamos (1974) 29) B. Dobratz, Ed, "Properties of Chemical Explosives and Explosive Simulants", **UCRL-51319, Rev 1**, LL Lab, Livermore, Contract No W-7405-Eng-48 (1974), pp 18-95 & 18-96 30) P.E. Karmer, "TATB GAP Testing, April-June 1974", **MHSMP-74-20K**, Mason & Hanger . . . , Amarillo, Contract DA-11-173-AMC-487(A) (1974) 31) P.E. Karmer, "TATB Sensitivity Testing. Period Covered: July-September 1974", **MHSMP-74-35T**, Mason & Hanger . . . , Amarillo, Contract DA-11-173-AMC-487(A) (1974) 31a) L.C. Myers, "Thermal Properties and Compatibility of TATB and TATB/Binder Systems. Period Covered: July-September 1974", **MHSMP-7435U**, Mason & Hanger . . . , Amarillo, Contract DA-11-173-AMC-487(A) (1974) 31b) C.S. MacDougall & L.M. Boyles, "Determination of Total Amination of TATB. Progress Report, January-March 1975", **MHSMP-75-20K**, Mason & Hanger . . . , Amarillo (1975) 32) H.D. Johnson, "Mechanical Properties of TATB/Kel-F 800 Formulations. Period Covered: April-June 1975", **MHSMP-75-24E**, Mason & Hanger . . . , Amarillo, Contract DA-11-173-AMC-487(A) (1975) 33) P.B. Bailey, "Problem of Thermal Instability of Explosive Materials", *Combstn&Flame* **23** (3), 329-36 (1974) & CA **82**, 142280 (1975) 34) R.N. Rogers, "Thermochemistry of Explosives", *ThermochimActa* **11** (2), 131-39 (1975) & CA **82**, 142281 (1975) 35) H.J. Sutherland & J.E. Kennedy, "Acoustic Characterization of Two Unreacted Explosives", *JApplPhys* **46** (6), 2439-44 (1975) & CA **83**, 149753 (1975) 36) J.D. Pastine & R.R. Bernecker, *JApplPhys* **45**, (10), 4458-68 (1974) & CA **82**, 32899 (1975) 37) G.T. West, "Formulation and Process Safety. Progress Report. July-September 1975", **MHSMP-75-40L**, Mason & Hanger . . . , Amarillo, Contract DA-11-173-AMC-487(A) (1975) 38) P.E. Kramer, "TATB Performance and Sensitivity. Period Covered: January-March 1976. Normal Process Development Endeavor No 106", **MHSMP-76-17M**, Mason & Hanger . . . , Amarillo (1976) 39) E. Catolano et al, "Thermal Decomposition and Reaction of Confined Explosives", **UCRL-78245**, LLL, Livermore (1976) & CA **86**, 192067 (1976) 40) R.H. Pritchard, "Initial Compatibility Evaluation of TATB Plastic-Bonded Explosive", **UCRL-77897**, LLL, Livermore, Contract No W-7405-Eng-48 (1976) 41) P.E. Rouse Jr, "Enthalpies of Formation and Calculated Detonation Properties of Some Thermally Stable Explosives", *JChemEngrgData* **21** (1), 16-20 (1976) & CA **84**, 92352 (1976) 42) R.K. Jackson & R.C. Weingart, "Detonation Properties of the Insensitive Explosive TATB", **UCRL-77755 (Rev 1)**, LLL, Livermore, Contract W-7405-Eng-48 (1976), (AD-A026051) & CA **85**, 179841 (1976) 43) J.S. Hallam, "TATB Formulation Study", **UCID-17087**, LLL, Livermore (1976) & CA **86**, 45332 (1976) 44) J.K. Carson, "Energy Deposition in TATB by Electrons at 50 and 100 MeV", **UCID-17192**, LLL, Livermore (1976) & CA **86**, 157800 (1976) 45) A.W. Campbell & R. Engelke, "Diameter Effect in High-Density Heterogeneous Explosives", **LA-UR-76-1115**, Los Alamos Sci Lab, Los Alamos (1976) & CA **86**, 157801 (1976) 46) R.K. Jackson & R.C. Weingart, "Detonation Properties of the Insensitive Explosive TATB", **UCRL 77755** or **CONF-760329-1**, LLL, Livermore, Contract W-7405-Eng-48 (1976) [also abstracted in CA **86**, 45331 (1977)]
NOTE: Apparently the same Ref as Ref 42 47) G.T. West, "Classification of Explosives. Period Covered: April-June 1976", **MHSMP-76-30K**, Mason & Hanger . . . , Amarillo, Con-

- tract DA-11173-AMC-487A (1976)
- 48) T.M. Benziger, "Insensitive Explosive . . .", USP 3985595 (1974) & CA **84**, 92357 (1976)
- 49) G.T. West, "Formulation and Process Safety, October-December 1976. Endeavor No 216", **MHSMP-77-5E**, Mason & Hanger . . ., Amarillo (1976)
- 50) G.D. Faubion, "Thermal Conductivity of TATB & TATB Blends by Differential Scanning Calorimetry. Period Covered: April-June 1976", **MHSMP-76-30C**, Mason & Hanger . . ., Amarillo, Contract DA-11173-AMC-487A (1976)
- 51) A.G. Osborn et al, "TATB PBX Formulation (Evaluation of Holston Process)", **MHSMP-77-18E**, Mason & Hanger . . ., Amarillo, Contract EY-76-C-04-0487 (1977)
- 52) D.R. Hardesty & J.E. Kennedy, "Thermochemical Estimation of Explosive Energy Output", *Combustn&Flame* **28** (1), 45-59 (1977) & CA **86**, 157804 (1977)
- 53) A. Delpuech & J. Cherville, "Relation Between the Electronic Structure and the Pyrotechnical Sensitivity of Secondary Nitrogen Explosives", *ProcSymp-ChemProblConnectedStabExplos* (1976) **4**, 179-99 (1977) & CA **87**, 120025 (1977)
- 54) V.I. Pepelkin & Yu.A. Lebedev, "Criterion for Estimating the Detonation Parameter of Explosives", *DoklAkadNaukSSSR* **234** (6), 1391-94 (1977) & CA **87**, 120023 (1977)
- 55) V.H. Evans, "Optimization of TATB Processing", **MHSMP-77-2**, Mason & Hanger . . ., Amarillo, Contract EY-76-C-04-0487 (1977)
- 56) W. Selig, "Estimation of the Solubility of 1,3,5-Triamino-2,4,6-Trinitrobenzene (TATB) in Various Solvents", **UCID-17412**, LLL, Livermore (1977) & CA **87**, 186686 (1977)
- 57) W.C. Davis, "Sensitivity of TATB Explosives", **LA-6676-MS**, Los Alamos Sci Lab, Los Alamos (1977) & CA **87**, 170033 (1977)
- 58) C.L. Schaffer, "Triaminotrinitrobenzene (TATB)/Kel-F: PBX Analysis", **MHSMP-76-46C**, Mason & Hanger . . ., Amarillo (1976) & CA **87**, 203824 (1977)
- 59) Anon, Group WX-3 HED-021 Phase 4 Proposal, February 25, 1977, Los Alamos Scientific Laboratory, Los Alamos, NM (1977)
- 60) T.M. Benziger, "Method for the Production of High-Purity Triaminotrinitrobenzene", USP 4032377 (1976) & CA **87**, 134491 (1977)
- 61) Z.L. Estes, "Trichloronitrosobenzene—A Raw Material for TATB Synthesis", **MHSMP-77-25**, Mason & Hanger . . ., Amarillo (1977)
- 62) Z. Estes. "Summary of Chlorine Free Synthesis of TATB. Process Development Endeavor No 106", **MHSMP-77-57**, Mason & Hanger . . ., Amarillo (1977)
- 63) P.E. Kramer, "Performance and Sensitivity Testing of TATB, Period Covered: July-September 1977", **MHSMP-77-52**, Mason & Hanger . . ., Amarillo, Contract No EY-76-C-04-0487 (1977)
- 64) W.T. Quinlin & J.G. Locke, "TATB Dry Amination Fine Particle Process. Period Covered: July-September 1977", **MHSMP-77-53**, Mason & Hanger . . ., Amarillo, Contract No EY-76-C-04-0487 (1977)
- 65) T.M. Benziger, "Method for the Production of High-Purity Triaminotrinitrobenzene", USP 4032377 (1977) & CA **87**, 134491 (1977)
- 66) H.H. Cady, Los Alamos Scientific Laboratory private communication with R.N. Rogers (1977)
- 67) A.G. Osborn et al, "TATB PBX Formulation . . .", *ProcDevEndeavor* **106**, **MHSMP-77-18E**, Mason & Hanger . . ., Amarillo, Contract EY-76-C-04-0487 (1977)
- 68) P.E. Kramer, "Performance and Sensitivity Testing of TATB. Period Covered: January-March 1977", **MHSMP-77-181**, Mason & Hanger . . ., Amarillo (1977) & CA **88**, 123387 (1978)
- 69) E.D. Loughran et al, "Influence of Metals on the Thermal Decomposition of S-Triaminotrinitrobenzene (TATB)", **LA-UR-77-857**, Los Alamos Sci Lab, Los Alamos (1977) & CA **88**, 107539 (1978)
- 70) J.A. Crutchmer, "TATB Formulation Study", **MHSMP-77-20**, Mason & Hanger . . ., Amarillo (1977) & CA **88**, 123389 (1978)
- 71) L.C. Myers, "X-0290 Coupon Test. Period Covered: January-March 1977", **MHSMP-77-11**, Mason & Hanger . . ., Amarillo (1977) & CA **88**, 107535 (1978)
- 72) A.G. Osborn et al, "TATB PBX Formulation (Evaluation of Holston Process)", **MHSMP-77-18E**, Mason & Hanger . . ., Amarillo (1977) & CA **88**, 107531 (1978)
- 73) A.G. Osborn et al, "TATB PBX Development (Particle Size)", **MHSMP-88-18D**, Mason & Hanger . . ., Amarillo (1977) & CA **88**, 107532 (1978)
- 74) A. Popolato & W.C. Davis, "The Insensitive Explosives Nitroguanidine and Triaminotrinitrobenzene", Los Alamos Sci Lab, Los Alamos (1978)
- 75) J.R. Kolb & H.F. Rizzo, "Growth of 1,3,5-Triamino-2,4,6-trinitrobenzene (TATB) I. Anisotropic Thermal Expansion", **UCRL-81189**, LLL, Livermore (1978)
- 76) A.G. Osborn & T.L. Stallings, "TATB PBX Formulation (Recycling Scrap PBX)", **MHSMP-77-18F**, Mason & Hang-

er . . . , Amarillo (1977) & CA **88**, 107530 (1978) 77) R.H. Pritchard, "Compatibility of TATB PBX with Weapons Materials", *Compat-PlastOtherMatExplos,Proplnts,PyrotsSymp* (1976), III-A & CA **87**, 87227 (1978) 78) Z.L. Estes, "Trichloronitrosobenzene: A Raw Material for TATB Synthesis", *MHSMP-77-25*, Mason & Hanger . . . , Amarillo (1977) & CA **89**, 8502 (1978) 79) Z.L. Estes, "Chlorine Free Synthesis of TATB", *MHSMP-77-24*, Mason & Hanger . . . , Amarillo (1977) & CA **88**, 19397 (1978) 80) B.M. Dobratz et al, "The Sensitivity of Triaminotrinitrobenzene (TATB) and TATB Formulations: Summary Report", **UCID-17808**, LLL, Livermore (1978) 81) D. Ornellas, LLL, Livermore, private communication with R.N. Rogers (1979) 82) M. Urizar, Los Alamos Sci Lab, private communication with R.N. Rogers (1979) 83) T.M. Benziger, *Ibid* (1979) 84) J.R. Kolb & H.F. Rizzo, "Growth of 1,3,5-Triamino-2,4,6-Trinitrobenzene (TATB). I. Anisotropic Thermal Expansion", *Proplnts&Expls* **4** (1), 10-16 (1979)

TAX. Code name for 1,5-Dinitro-3-acetyl-1,3,5-triazine. See in Vol 1, A50-L under "1-Aceto-3,5-dinitro-1,3,5-triazacyclohexane . . ."

TBB (Tri-n-butylborane or Tri-n-butylborine). $(\text{CH}_3\text{CH}_2\text{CH}_2\text{CH}_2)_3\text{B}$; mw 182.20; colorl pyrophoric liq; fp -34° ; bp 170° at 222mm; d 0.747g/cc at 25° ; RI 1.4285 at n20/D. Sol in most org solvents; not sol in w. CA Registry No [122-56-5]. Prepn is by heating an ethereal mixt of the Triphenyl ester of boric acid with n-butylMgB.. The reaction prod is distld off at 95° under N_2 . TBB has a flash pt of 0° and is considered a highly dangerous fire risk which must be stored and used under an inert atmos (Refs 2 & 4)

Wells (Ref 2) recommends TBB for use as a fuel in high Mach number aircraft jet motors because of its v high flame speed and blowout velocity, "with the unique safety feature that it doesn't burn when exposed to air, but must be sparyed before it exhibits its pyrophoric characteristics . . ."

Refs: 1) Beil **4**, [1022] 2) R.A. Wells, "High Energy Fuels for Aviation", *MechEngrg* **80**,

55-59 (1958) & CA **52**, 21016 (1958) 3) G. Brauer Ed, "Handbook of Preparative Inorganic Chemistry, Vol 1, 2nd Edn, Academic Press, NY (1963), 799 4) L. Bretherick, "Handbook of Reactive Chemical Hazards", CRC, Cleveland (1975), 597 5) *CondChem-Dict* (1977), 875

TDBP Detonation Wave. See in Vol 4, D582-L to D583-L

TEA (ATE, Triethylaluminum or Aluminum triethyl). $(\text{C}_2\text{H}_5)_3\text{Al}$; mw 85.12; colorl pyrophoric liq; fp -52.5° ; bp 194° ; sp grav 0.837 Miscible with saturated hydrocarbons. CA Registry No [97-93-8]. Prepn is by introduction of ethylene and H_2 into an autoclave contg Al. The reaction proceeds under moderate temp and at varying press. TEA has a flash pt of -63°F . It reacts violently with acids, alcohols, amines, halogens and w (Ref 4)

Because it ignites sponty in air, TEA is hypergolic with liq O and, hence, has been suggested for use as a rocket and turbo-jet engine (*proplnt*) fuel by Wells (Ref 2)

According to Tulis (Ref 4, p 246), in reporting on the use of TEA as a pyrophoric flame agent, ". . . The predictive models and computer simulations have guided research with thickened triethylaluminum, TEA, a pyrophoric flame agent which has led to an effective flame kill mechanism - the controlled fireball. The ability to control several key parameters such as the viscoelastic properties, a material's resistance to movement or to breakup, and the ignition delay, the time frame within which TEA first is exposed to the atmosphere and when it ignites, permits design and control of the generated fireball. The critical factor, however, is the coupling of these parameters with the total energy of the flame system to form a cloud of uniformly fine particles and to delay the ignition of these particles until the cloud has grown to the desired size, at which point all the particles react simultaneously. The net result is a very effective fireball which releases almost all of its energy within a very narrow time frame, on the order of milliseconds. In many cases, the fireball radiation pulse exists for several seconds. However, for all practical purposes, 1 second is

sufficient for desired target defeat because a high heat flux absorbed in a short time allows only a small portion of the energy to be dissipated by the target. . . ."

TEA is considered highly toxic, being v destructive to living tissue (Ref 3)

For addnl information on TEA see under "Pyrophoric Incendiary Agents" in Vol 8, P503-L to P504-R

Refs: 1) Beil 4, [1024] 2) R.A. Wells, "High Energy Fuels for Aviation", MechEngrg 80, 55-59 (1958) & CA 52, 21016 (1958) 3) Sax (1968), 1186 4) M.A. Tulis et al, "Controlled Fireballs-Effective Kill Mechanism for Flammable Targets", EA, APG (1974), AD-785691 5) CondChemDict (1977), 881; also, a *Limited Dist Ref*: L.W. Burggraff, "Test of the Triethylaluminum (TEA) Based Components Fuel Munition", ADTC-TR-73-26, Elgin AFB (1973)

TEB (Triethylborane, Triethylborine or Boron Triethyl). $(C_2H_5)_3B$; mw 98.13; colorl pyrophoric liq; mp -93° ; bp 95° ; d 0.6961g/cc at 23° ; RI 1.3971. Miscible with most org solvents; immiscible with w. Prepn is by dropwise addn of an n-butyl eth soln of BF_3 to a soln of ethyl Mg bromide in n-butyl eth. Upon completion of the reaction the prod is distld off at 95° under N_2 . Also, by the reaction of triethyl Al with B halide, or diborane with ethylene. TEB has a flash pt of 0° ; a Q_c of 20000BTU/lb and, according to Sax (Ref 4), a high vap toxicity

Although Wells (Ref 2) recommends TEB as a jet motor fuel for high speed aircraft, he cautions that TEB is ". . . extremely destructive to living tissue and on contact with the skin produce(s) a combined effect of dehydration and thermal burn. The reaction is immediate and deep burns with subsequent scarring result . . ."

For information on the mil usage of TEB see Vol 8, p 504-L under "Pyrophoric Incendiary Agents"

Refs: 1) Beil 4, [1022] 2) R.A. Wells, "High Energy Fuels for Aviation", MechEngrg 80, 55-59 (1958) & CA 52, 21016 (1958) 3) G. Brauer, Ed, "Handbook of Preparative Inorganic Chemistry", Vol 1, 2nd Edn, Academic Press, NY (1963), 799 4) Sax (1968), 483 5) Bretherick (1975), 513 6) CondChemDict (1977), 882

Tees Powder. Brit permitted expl which passed the Buxton test. It contained NG 10, AN 60, woodmeal 10 & Na chlorate 20%. BalPend swing 2.55"

Refs: 1) Marshall 3 (1932), 120 2) Thorpe 4 (1949), 554

Teflon. See in Vol 8, P351-L to P352-R under "Polytetrafluoroethylene" and the following *Addnl Ref*: D.M. Cavagnaro, Ed, "Polytetrafluoroethylene (Teflon)", Vol 2, NTIS/PS-78/0269 (1978) [A bibliography in which worldwide citations of engrg research in the reactions, properties, performance and manuf of Teflon are presented]

TEFO [Bis(1,1,1-trinitroethyl) formal]. $[(O_2N)_3C.CH_2.O.]_2CH_2$, $C_5H_6N_6O_{14}$; mw 374.17; N 22.45%; OB to CO_2 +4.28%; cryst; mp 65.3 to 65.5° ; d 1.72g/cc. Sol in methanol. Prepn is by reaction of trinitroethanol with paraformaldehyde in the presence of concd sulfuric acid (as a dehydrating agent) with rapid stirring at $25-30^\circ$. The crude TEFO is filtered off, dissolved in methanol and recryst by w addn. The product is dried by vac desiccation. The yield varies from 55-65% to 80%

TEFO has a ΔH_f of -286 cal/g and an impact sensy of 78 ± 9 cm (using a 2-kg wt) when dry, and 121 ± 12 cm when wet with CCl_4

Refs: 1) Beil, not found 2) M.E. Hill & K.G. Shipp, "Nitroalcohol Acetal Preparation in Sulfuric Acid, I. Synthesis of Bis(Trinitroethyl) Formal, TEFO", NAVORD 6672 (1959) 3) C.F. McDonough et al, "TEFO Summary Report November 1961-March 1963", American Cyanamid Co, New Castle, Contract NOw-60-0745-C (1963) 4) J.R. McCandless, "TEFO Summary Report January 25-February 12, 1965", Ibid (1965)

TEGDN (Triethyleneglycoldinitrate, 2,2-Ethylenedioxydiethylidinitrate, Triglykoldinitrat (Ger), Dinitrate de triethylèneglycol (Fr) or TEGN). $O_2N.O.CH_2.CH_2.O.CH_2.CH_2.O.CH_2.CH_2.O.NO_2$; $C_6H_{12}N_2O_8$; mw 240.20; N 11.67%; OB to CO_2 -66.6%; light yel, oily liq; mp -19° ; d 1.335g/cc; RI 1.4540. V sol in acet, eth, 2:1 eth-ethanol; sol in carbon disulfide; sl sol in w. CA Registry

No [111-22-8]

Prepn consists of first purifying triethylene glycol by fractional distillation under vacuum in an 18" Vigreux fractionating column. The assembly as a whole is equivalent to 4.5 theoretical plates. The distillation is conducted using a 5 to 1 reflux ratio, at a pot temp of approx 180°, and a take-off temp of approx 120°

The purified triethylene glycol is nitrated by carefully stirring it into 2.5p of 65/30/5 nitric acid/sulfuric acid/w maintained at 0 ± 5°. The rate of cooling is sufficient that 300g of triethylene glycol can be added within 40 minutes. The mixt is stirred and held at 0 ± 5° for 30 addnl minutes. It is then drowned by pouring over a large quantity of ice and extracted three times with eth. The combined extract is w-washed to a pH of about 4, shaken with an excess of Na bicarbonate soln, and further washed with 1% Na bicarbonate soln until the washings are colorless. The ethereal soln is w-washed until it has the same pH value as distld w. It is carefully separated from excess w, treated with chemically pure Ca chloride to remove dissolved w, and filtered. The eth is removed by bubbling with dry air until a minimum rate of loss is attained. The TEGDN yield is 1.34g/g of triethylene glycol (84% of theoretical) and the N content of different batches ranges from 11.60 to 11.69% by the nitrometer method (calcd 11.67%) (Refs 1, 2, 4, 10a & 21)

A modification of the above prepn by Ayerst (Ref 23) allows for continuous nitration. This procedure recommends the use of sufficient CH_2Cl_2 to maintain the temp at 11° and to ensure a safe degree of dilution of the product. The triethylene glycol and the mixed acid nitrating agent (without w) are separately dispersed in CH_2Cl_2 prior to mixing. The 74% yield is recovered by evapn of the CH_2Cl_2

TEGDN has a brisance by 200g Sand Bomb Test of 14.7g (TNT 48.0g); deflagration pt of 195°; deton vel of <2000m/sec under heavy confinement (no deton under (relatively light) steel confinement at a d of 1.33g/cc and a diam of 1.25"); a 5 sec expln temp of 225° (0.02g sample wt); friction pendulum test, unaffected with both fiber and steel shoes; an impact sensy of 100+ (cm) using a BM appar with a 20-mg sample, 43" with a PicArns appar; heat of combustion of 3428cal/g at 18mm, or 819.2kcal/

mole (at const press), or 836.60kcal/mole (Q_c^v - ref liq w) (Ref 9); heat of expln of 750 kcal/kg (at const press) (Refs 2 & 9a) or 676 kcal/mole(Q_c^v) (Ref 9); heat of formation of -576.6kcal/kg (at const vol) or -603.7kcal/kg (at const press); heat test at 100° (using a 0.6g sample) of 1.8% loss in wt in the 1st 48 hrs and 1.6% in the 2nd 48 hrs, with no expln in 100 hrs; power by Trauzl test of 320cc (Ref 10a); vac stab at 100° of 0.45cc of gas/40 hrs, and at 120° of 0.8 to 0.99cc of gas/g/8 hrs (Refs 2, 9 & 10a); vap press of <0.001mm at 25°; viscosity of 13.2cps 20° and volatility at 60° of 40mg/sq cm/hr (Ref 9)

The following are selected examples of the uses of TEGDN in expls, proplnts and pyrots:

Roberts (Ref 13) suggests the use of TEGDN in liq expls for fracturing geological formations so as to increase the permeability and flow in oil, gas or w wells. The patented expls are claimed to be insensitive to electrical discharge, mechanical shock, temp, order of mixing, or dilution by gas, w or oil. They can be pumped into fissures without decompn and have a critical diameter of ~0.4mm. A typical compn incorporates Tetranitromethane 50-80, TEGDN 7-20, RDX 5-10, 8-15, Al 5-10, NC 1-5, chalk 1-3, and glycerol linoleate 0-4%. Wells (Ref 16) reports the use of TEGDN as a plasticizer in the fabrication of exptl flexible sheet expls of the following compn range: RDX 20.7-31.5, NC 4.0-5.9, TEGDN 0-4.1, diethyleneglycol dinitrate 0-5.0, Trimethylol-ethane trinitrate 10.0-40.8 and pigment 0.3-0.4g. Twenty to thirty ml of ethanol are added to the mixt to form a paste which is then rolled into a rubbery sheet. No characterization tests were run on the compns contg TEGDN. In Ref 24 Wells suggests a formulation including 60-75% HMX with a balance of TEGDN-NC in a ratio of approx 5:1 which is formed into expl sheets claimed to have good energetic properties and resistance to cracking and bending at -45°. In another patent (Ref 24a), Wells claims that smooth, tough elastic expl sheets resistant to bending at -10° and sensitive to a 2-kg hammer dropped 15" are obtd from a formulation contg HMX 340, Nitrostarch 70, DPA 3.5, TEGDN 90g and ethyl acetate 75ml. In another invention, Wells (Ref 25) suggests that a flexible (at ≥ -40°) expl can also be obtd in-

corporating HMX 68, Nitrostarch 14, TEGDN 18, DPA 0.7% and $\sim 70\text{ml}/100\text{g}$ of mixt of ethyl acetate. The paste so formed is then rolled into sheets 6.2mm thick which are claimed to have the following characteristics: deton vel of 8219m/sec; d of 1.59g/cc; BalPend value of 1.316 (TNT=1.0); bullet impact value of no fire or expln; friction pendulum value (steel shoe) of no crackle, fire or expln; cap sensy to a No 8 blasting cap; and cold temp operation at 10°

Camp et al (Ref 12) claim a liq monopropnt useful for underwater propulsion with high combustion efficiency, low fp, reduced shock sensy, low volatility and low toxicity. The suggested formulation range is TEGDN 84.9–94.9, Metriol trinitrate 5–15 and ethyl centralite 0.1%. Forbes and Coleburn (Ref 15) in reporting on the deton threshold properties of liq propnt NOSET-A, a mixt of TEGDN/dibutyl sebacate/ethyl centralite (96/3/1%), conclude that the deton vel of the propnt is strongly affected by temp. For example, when heavily confined at 60°F , NOSET-A exhibits a deton vel of 5950m/sec; however, no deton occurs under the same confinement at 29°F . They also report that the deton pressure of NOSET-A at 55°F is 170kbars, and that wedge tests indicate a deton threshold at 110–130kbars transmitted shock pressure

One of the primary uses of TEGDN has been as an NC plasticizer in propnts, gelatinizing NC better than NG and having better chemical stability than NG. A typical example of this type of propnt is given in the patent of Zucker et al (Ref 18), who claim that a double base propnt contg TEGDN can be prepd which will not disintegrate upon firing in high pressure systems. Their formulation includes trimethylolethane 24–26, TEGDN 9.6–10.4, and Diethyleneglycoldinitrate 4.8–5.2%. In another such patent, Shinohara et al (Ref 22) claim solid propnts having high mechanical strength at low temps, incorporating NC 51, NG 25, TEGDN plus trimethylolethane 20, and a stabilizer plus a combustion adjusting agent 4%. Characteristic properties of these propnts are reported as: an impact strength of 0.20 and $0.05\text{kg}\cdot\text{m}/\text{cm}^2$ at 20° and -50° , respectively; a tensile strength of 70 and $250\text{kg}/\text{cm}^2$ at 20° and -50° , respectively; and an elongation of 30 and 8%, also at 20°

and -50° , respectively. These values are compared to the properties of conventional propnts which are reported as 0.15 and $0.01\text{kg}\cdot\text{m}/\text{cm}^2$, 90 and $400\text{kg}/\text{cm}^2$, and 30 and 4%. Mosher (Ref 26), in his invention claims a solventless double base propnt having superior strength and performance can be prepd using a nonmigrating plasticizer consisting of Metriol trinitrate and TEGDN in a ratio of at least 14:1. He reports a typical formulation incorporating Metriol trinitrate 38.5, NC 46, TEGDN 3, ethyl centralite 2, basic Pb carbonate 1, K sulfate 1, dibutylphthalate 8.4% and candelilla wax with characteristic properties of a d of $0.054\text{lb}/\text{in}^2$, an initial vel of 5.5ft/sec, flame temp of 2260°K , and an impetus of $3.56\times 10^6\text{inch}\cdot\text{lbs}/\text{lb}$

Experimentation using TEGDN as a plasticizer in flow-cast pyrot flare compns has shown that a dramatic improvement in flare luminous efficiency can be obtained because of the high oxygen content (53.3%) of TEGDN. Other factors favorable to its useage are its relative safety over other nitrate esters such as NG, and better combustion and castability over other plasticizer-binder systems investigated. A typical flare development program stressing these points is reported by Lane et al (Ref 10). An exptl flare formulation evaluated by the authors during this program incorporated Mg ($40\mu/200\mu$ mixt) 49.0, Na nitrate (400 mesh or $38\mu\text{m}$) 27.0, glycerin diglycidyl ether 7.06, maleic anhydride 4.94, and TEGDN 12.00%. The properties reported for their formulation are: a burning rate of $0.058\text{in}/\text{sec}$, a luminous efficiency of $59,400\text{cd}\cdot\text{sec}/\text{g}$, good storage stability at 70° for 4 to 12 weeks, and a viscosity of 117,500cps at 25° . Swotinsky et al (Ref 14) claim in their patent the development of flare fuel compns equivalent in light efficiency to standard flare compns, although contg only 65% of the fuel and oxidizer usually found in standard compns. They attribute the efficiency increase to their use of an energetic binder system featuring TEGDN

According to Anderson & Mehl (Ref 17), TEGDN is very toxic. It acts as a violent poison when ingested by rats or as a peripheral nerve block when selectively applied. Dermal application of 21mmoles/kg of body wt in rabbits causes death in 2 to 3 weeks. In a later study by Anderson et al (Ref 19) the 24 hr intraperitoneal

LD₅₀ in rats was found to be 995 (932 to 1063 range) mg/kg of body wt

Refs: 1) Beil 1, {2111} 2) P.F. Macy & A.A. Saffitz, "Basic Research Leading to the Development of Ideal Propellants. Explosive Plasticizers for Nitrocellulose", PATR 1638 (1947) 3) P. Varrato, "Manufacture of Triethylene Glycol Dinitrate on a Semi-Plant Scale", PATR 1767 (1950) 4) P. Aubertein, "Preparation and Properties of Several Glycol Nitrates", MP 30, 7-42 (1948) & CA 45, 354 (1951) 5) L. Médard, "Shock Sensitivity of Liquid Nitrate Esters", MP 31, 131-43 (1949) & CA 46, 11685 (1952) 6) Anon, "Report on Study of Pure Explosive Compounds", Part IV, ADL, Cambridge, Contract No DA-19-020-ORD-47 (1952), 549 7) J. Boileau & M. Thomas, "Viscosities and Indexes of Refraction of Various Liquid Nitrate Esters", MP 33, 155-57 (1951) & CA 47, 5200 (1953) 8) R.B. Norden, "Preparation of Triethylene Glycol Dinitrate on a Semi-Plant Scale", PATR 1953 (1953) 9) Anon, ADL (1961) 1, Compd 723, p 19 Card Set 01.10, p 10 Card Set 01.11, p 2 Card Set 53.06, p 12 Card Set 54.01, p 13 Card Set 54.02 and p 6 Card Set 54.03 9a) Urbański 2 (1965), 154-55 10) G.A. Lane et al, "Research and Development of Flow-Cast Magnesium Flares", AFATL-TR-71-120 (1971) (AD-902122) 10a) Anon, EngrDesHdbk, "Explosives Series—Properties of Explosives of Military Interest", AMCP 706-177 (1971), 367-79 11) J.A. Carrazza, Jr et al, "Evaluation of Castable Illuminant Formulations in Flare, Surface, Trip, M49A1", PATR 4295 (1972) (Limited distribution, not used in this article) 12) A.T. Camp et al, "Liquid Nitrate Ester Monopropellant Compositions", USP 3634158 (1972) & CA 76, 74452 (1972) 13) L.N. Roberts, "Liquid Explosives for Fracturing Geological Formations", FrP 2068343 (1971) & CA 76, 129586 (1972) 14) J.M. Swotinsky et al, "Castable Metallic Illuminant Fuel Containing a Nitrocellulose Plasticized Binder", USP 3715248 (1973) & CA 78, 126462 (1973) 15) J.W. Forbes & N.L. Coleburn, "The Shock-To-Detonation Transition in a Triethylene Glycol Dinitrate (NOSET-A)", NOLTR 73-117 (1973) 16) F.B. Wells, "Development of a High-Energy Flexible Sheet Explosive", PATR 4713 (1974) 17) M.E. Anderson & R.G. Mehl, "A Comparison of the

Toxicology of Triethylene Glycol Dinitrate and Propylene Glycol Dinitrate", NavToxUnit, Bethesda (1973), (AD 776831) & CA 80, 128943 (1974) 18) J. Zucker et al, "Nitrocellulose Doublebase Propellant Containing Ternary Mixture of Nitrate Esters", USP 3867214 (1975) & CA 83, 63047 (1975) 19) M.E. Anderson et al, "Some Neurotoxic Properties of Triethylene Glycol Dinitrate", ToxicolApplPharmacol 1976, 36 (3), 585-94 & CA 85, 138134 (1976) 20) F.B. Wells & J.R. Hendrickson, Sr, "High Energy Flexible Explosive. II. The Dynamite Grade Nitrocellulose/Triethyleneglycol Dinitrate Binder System", PATR 4847 (1976) (Limited Distribution, not used in this article) 21) R. Meyer, "Explosives", Verlag Chemie, NY (1977), 137 & 298 22) M. Shinohara et al, "Solid Propellant", JapP 7640129 (1976) & CA 86, 123921 (1977) 23) R.P. Ayerst, "Improvements in the Manufacture of Nitric Esters", BritP 1444341 (1976) & CA 86, 43176 (1977) 24) F.B. Wells, "Flexible Explosive Composition Comprising Particulate RDX, HMX, or PETN and a High Viscosity Nitrocellulose Binder Plasticized with TEGDN", USP 4014720 (1977) & CA 86, 192089 (1977) 24a) F.B. Wells, "Flexible Explosive Composition Comprising Particulate RDX, HMX, or PETN and a Nitrostarch Binder Plasticized with TEGDN or TMETN", USP 4014719 (1977) & CA 86, 192088 (1977) 25) F.B. Wells, "High-Energy Flexible Explosive: III. The Nitric Ester-Plasticized Nitrostarch Binder System", ARLCD-TR-77043 (1977) & CA 87, 203830 (1977) 26) P.R. Mosher, "Solventless Double Base Propellants for Plasticizing MTN Nitrocellulose Propellants Without Use of Solvents", USP 4082583 (1978) & CA 89, 45945 (1978)

Teledet. Proprietary thin layer w-based slurry expl developed by Teledyne McCormick Selph to be used for fracturing mineral formations. Its consistency can be adjusted from about 5000 centipoise to an essentially solid gel by variations in the concns of the thickener and cross-linking agent. A compn viscosity of approx 10000 centipoise is most often used

Expl classification, Class A Type III; d, 1.42 g/cc; deton vel, 6540 & 6740m/s (sep values); deton press (calcd), 128kbar; card gap sensitivi-

ty, $1.25 > < 1.50''$; static sensitivity, no initiation at 12.5 joules; drop wt sensitivity, $> 250\text{cm}$ BuMines app, 2-kg wt; min propagation thickness, $1/64''$; cap sensitivity, No 6 cap; temp stability, 200°F unlimited, 250°F no decompn shown by DSC, decompn 281°F ; appearance, white fluid (Ref 2)

Its nominal compn is ultra-fine particle PETN, 20–50; 60% AN soln, 0–80; diethyleneglycol, 0–25; guar gum or polyacrylamide, 0.1–0.3; and w to make 100%. A cross-linking agent (Ti tetraisopropoxide) is added as required

Teledet has also been recommended for use with flame suppressors as a fire lane clearance charge, and as an anti-tank/anti-personnel mine clearing agent (Ref 3)

Avrami & Jackson (Ref 4) subjected two Teledet compns representing extremes of viscosity (PETN, 38.0 ± 0.5 ; 60% AN soln, 27 ± 0.5 ; diethyleneglycol, 9 ± 0.5 ; guar gum, 0.5; water, 25 ± 0.5 ; and either 0.05 or 0.15% Ti tetraisoperoxide) to a series of safety and performance tests in order to characterize the slurry expl as a potential candidate for military use.

Comparisons were made relative to safety performance and cost with other expl materials. It was concluded that the most favorable features of Teledet are its good safety characteristics, good chemical and thermal stability (for a slurry expl), easy emplacement, and the ability to propagate in small diameters. The features that detract are the metal acceleration capacity which is about 75% that of TNT, the separation of ingredients in low-viscosity Teledet, and the higher cost, relative to other slurry expls

Refs: 1) C.D. Forrest, "Thin Layer Propagating Slurry Explosive", USP 3912560 (1975)
2) Anon, "Teledet™ Slurry Explosive", Teledyne McCormick Self, Hollister, Calif (no date)
3) Anon, "Teledet™ Minefield Neutralization Demonstration", Teledyne McCormick Self (1975)
4) L. Avrami & H.J. Jackson, "The Characterization of a Slurry Explosive—Teledet", ARLCD-TR-78077 (1979)

Telemetry. Telemetering in a broad sense involves the transmission of data by any means from a remote and usually inaccessible point to

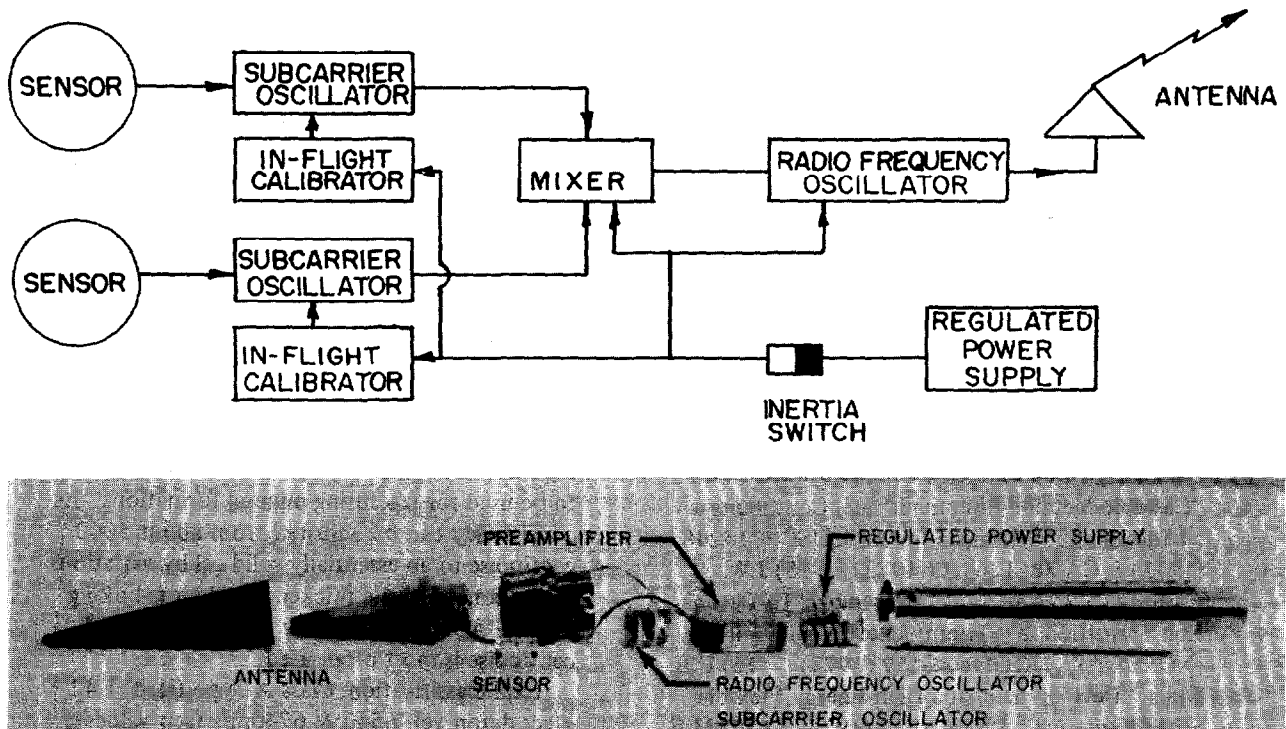

Fig 1 Typical VHF High-g Telemetry System

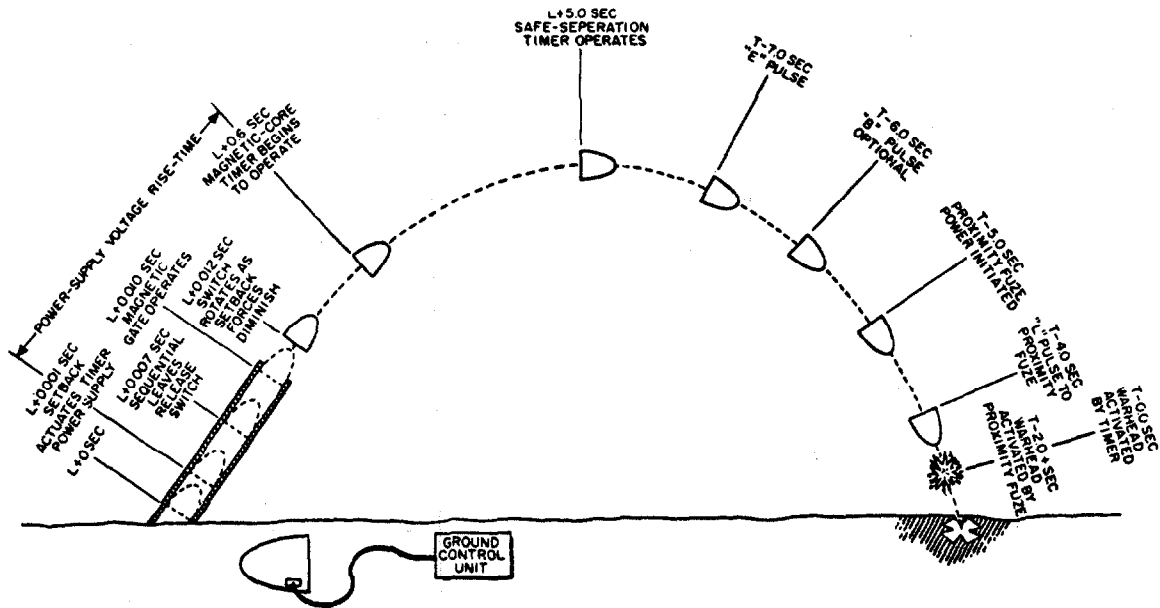

Fig 2 Sequence of Events

an accessible location (Ref 1). Usually, telemetering refers to electrical means of acquiring and transmitting data, transmission usually being accomplished by means of an RF link from the munition to a ground station. The requirement for telemetering data from fuzes may be quite severe, as in the artillery fuze where survival of the telemetering transmitter, power source, and antenna is essential under accelerations in excess of 50000g during setback. A typical system meeting these requirements is shown in Fig 1 (Ref 3)

Transducers in the device being tested convert the variable being measured into an electrical signal that subsequently is used to modulate the carrier of an RF transmitter. The signal is received, amplified, and demodulated on the ground, and recorded on magnetic type or on an oscillograph for subsequent analysis

Fig 2 shows the sequence of events of an electronic programmer system for a projectile. The projectile was equipped with a telemetry unit that transmitted the frequency of both oscillators and the outputs from both channels. The outputs occurred at T-70, T-60, T-40 and T-00 secs. The purpose of the test was primarily to determine if the decade dividers, output logic, and firing circuit would operate

properly after being subjected to gun-fired environments (Ref 2)

Refs: 1) P.A. Borden & W.J. Mayo-Wells, "Telemetering Systems", VanNostrand Reinhold, NY (1959) 2) O.T. Dellasanta & F.W. Kinzelman, "Electronic Programmer System for XM471 Projectile", Proc Electronic Timers for Ordnance Symp, Vol 1, US Army Harry Diamond Labs (1965), 21-58 3) W.H. Mermagen et al, "VHF and UHF High-G Telemetry Instrumentation for HARP Vehicles", BRL Memo Rept 1768, Aberdeen Prov Grnd, Md (1966)

Television Guidance. If a missile is to be fired against a target beyond visual range, a cathode ray viewer rather like a TV screen is used. The precise position of the target, if fixed and known, can be set up on the screen. The missile can then be tracked by radar in flight, and its "blip" steered into the target. Greater accuracy can be achieved by fitting a small TV camera into the nose of the missile. Then, as it approaches the target, the controller receives a TV picture of the target area and can steer the missile to a precisely-chosen pinpoint. Such techniques have enabled controllers in aircraft to hit a particular bridge, support or part of a ship beyond

visual range

An advantage of such a system is that the launch aircraft can turn back toward its base once the missile has been launched, without any loss of control over the flight path. This permits launch and control over "stand-off" ranges, beyond the reach of the target's close defenses

Another TV guidance technique entails "locking" the camera onto the target before launching the missile, which will then home automatically on where the camera is aimed, by means of on board electronics

Also see under "Smart Bombs" in this Vol Ref: C. Chant, Ed, "How Weapons Work", Henry Regnery, Chicago (1976), 244

Tellurium (Aurum paradoxum or Metallum problematum). Te; at w 127.60; at no 52; valence 2,4,6; diatomic (Te_2) in the vap state; eight stable isotopes: 120(0.089%), 122 (2.46%), 123 (0.87%), 124 (4.61%), 125 (6.99%), 126 (18.71%) 128 (31.79%) and 130 (34.48%); artificial radioactive isotopes: 114-119, 121, 127, 129 and 131-134; greyish-white, lustrous, brittle crystn solid, hexagonal, rh structure or dk grey to brown amorph powdr with metallic characteristics; mp 449.8°; bp 989.9°; d 6.11-6.27g/cc. Sol in nitric acid, KCN soln, concd sulfuric acid and K hydroxide; not sol in benz, carbon disulfide or w. CA Registry No [13494-80-9]. Te is present in the earth's crust to the extent of 0.002ppm. It occurs as telurides in combination with metals in the minerals tetradymite, altaite, coloradolite; it is found as the dioxide tellurite; it is also found in conjunction with Ag and Au. Prepn is by redn of telluric oxide with SO_2 or by dissolving the oxide in a caustic soda soln and plating out the metal

According to Ellern (Ref 2), Te (along with Se and S) belongs to a group called the *chalcogens* which can be used in pyrots as either a fuel or an oxidizer. As an oxidizer, Te is used for blasting cap initiation compns along with Mg, Pb or Zn as the fuel. Principal useage as a fuel has been as an ingredient in delay trains for detonators, examples of which are shown in Table 1

The recommended max allowable concn of the dust in air is 0.1mg/m³. Ingestion of Te causes nausea, vomiting and central nervous

Table 1
Detonator Delay Compositions Containing Te
(Ref 2, p 386)

Composition No 1	194	195
Composition		
Barium peroxide, %	40	70
Selenium, %	20	—
Tellurium, %	20	30
Rated burning time, sec/inch	9.0	4.4

system depression; ingestion also gives a garlic odor to both breath and perspiration

Refs: 1) Gmelin, Syst Nr 11 (1940) 2) Ellern, "Military and Civilian Pyrotechnics" (1968), pp 60, 209, 210, 284, 285, 322 and 386 3) Sax (1968), 1136 4) Merck (1976), 1178 (No 8864) 5) CondChemDict (1977), 840

Telsits. See under "Swiss Commercial Explosives of Nonpermissible Type" in Vol 3, C444-L

Meyer (Ref) states that *Telsit-Gelatine A or C* are trade names for gelatinous AN-NG expls distributed in Switzerland by Vereinigung Schweizerischer Sprengstoff-Fabriken:

	Density, g/cc	Pb block test, cc	Weight strength, %
A	1.4	375	83
C	1.4	305	75

He also notes that *Gamsit-Gelatine A or C* and *Aldorfit-Gelatine A or C* are identical products Ref: R. Meyer, "Explosives", Verlag Chemie, NY (1977), 257

Temperature of Detonation (and Explosion).

See "Detonation (and Explosion) Temperature and Its Determination" in Vol 4, D583-L to D589-L, and "Detonation (and Explosion), Temperature Developed On" in Vol 4, D589-L to D601-L

TEN. PETN (Russ); see under "Russian Explosives and Related Items" in this Vol

TeNA. Tetranitroaniline (USA); see in Vol 1, A411-L ff

TeNAns. Tetranitroanisole (USA); see in Vol 1, A454-L

TeNAzxB. Tetranitroazoxybenzene (USA); see in Vol 1, A667-R to A668-L

TeNB. Tetranitrobenzene (USA); see in Vol 2, B50-L to B50-R

TeNBPh. Tetranitrodiphenylamine (USA); see in Vol 5, D1433-R to D1434-R

TeNBu. Tetranitrobutane (USA); see in Vol 2, B367-R to B368-L

TeNCbz. Tetranitrocarbazole (USA); see in Vol 2, C48-L to C50-R

TeNDG. Tetranitrodiglycerine (USA); see in Vol 5, D1261-L to D1261-R

TeNMA. Tetranitromethylaniline (USA); see in this Vol under "Tetryl" and in Vol 8, M101-R

TeNMe. Tetranitromethane (USA); see in Vol 8, M83-L to M85-R

TeNN. Tetranitronaphthalene (USA); see in Vol 8, N14-R to N16-R

TeNOx. Tetranitrooxanilide (USA); see in Vol 8, O36-L & R

Tensile Strength of Explosives. Ref 2 contains tensile strength data obtained with the procedure outlined in **ASTM D638** (27) (1968),

189. Dumbbell-shaped specimens having a minor diameter of 0.5" were used for this test, and the cross head speed of the Tinius Olsen Universal Test Apparatus was set at 0.5"/sec. The data is presented on the following pages in Tables 1 & 2

Refs: 1) K.G. Hoge, *Explosivst* **18** (1970), 39-41
2) T.S. Costain & R.V. Motto, "The Sensitivity, Performance and Material Properties of Some High Explosive Formulations", *PATR* **4587** (1973)
3) B.M. Dobratz, "Properties of Chemical Explosives and Explosive Simulants", **UCRL-51319**, Rev 1, Lawrence Livermore Lab, Univ of Calif (1974), 7-15

Terephthalic Acid and Derivatives. See in Vol 8, P262-R to P265-R under "Phthalic Acid and Derivatives", and P214-R under "Terephthalic-diperoxy Acid"

Terminal Ballistics. Terminal ballistics is concerned with the principles underlying the effects of weapons on targets to include penetration, fragmentation, detonation, shaped charge, blast, combustion, and incendiary effects

In designing weapons and ammo, maximum desired terminal effect is a primary objective. A proper balance of many factors is essential to accomplish this purpose. The most important of these factors are shape, weight, and material used in the projectile; type and wt of expl charge; fuzing system; and terminal velocity

The science of terminal ballistics has lagged behind the companion sciences of *exterior* and *interior* ballistics (see Vol 2, B7-L to B8-L) primarily because of difficulties in obtaining basic data for study. Rapid advances in the fields of radiography (see in this Vol) and high speed photography (see Vol 2, C13-L to C19-R) have relieved the situation somewhat, but the problem of securing good data remains complex. For example, direct observation of the end product is possible only on fragmentation studies. Mechanisms by which these results were achieved can be determined only by statistical analysis of fragment distribution. However, newer developments and improvements in recording techniques

Table 1
Tensile Strengths of Typical Explosives

Explosive, Density	Test Temp, °F	Stress at Rupture, psi	Elongation at Rupture, %	Modulus of Elasticity, psi x 10 ⁻³	Work to Produce Rupture, ft-lb/in ³
<u>Composition A-3</u> (RDX 91/wax 9%) d = 1.65g/cc	-80	291	.018	1996	.002
	-40	321	.041	1206	.006
	73	164	.041	731	.004
	125	50	.021	330	.0005
	160	26	.014	230	.0001
<u>Composition B</u> (RDX 59.5/TNT 39.5/ wax 1%) d = 1.72g/cc	-80	95	.008	1580	.0004
	-40	142	.011	1540	.007
	73	208	.015	1696	.001
	125	102	.007	2408	.0004
	160	40	.007	1426	.0002
<u>Composition B-3</u> (RDX 59.5/TNT 40.5%) d = 1.73g/cc	-80	55	.018	478	.0006
	-40	145	.014	1458	.0008
	73	109	.007	2141	.0004
	125	82	.012	938	.0005
	160	56	.015	693	.0004
<u>75/25 Cyclotol</u> (RDX 75/TNT25%) d = 1.75g/cc	-80	98	.011	1021	.0005
	-40	119	.014	1011	.0007
	73	225	.114	275	.012
	125	159	.013	1466	.0013
	160	60	.013	846	.0004
<u>Composition H-6</u> (RDX 44/TNT 29.5/ Al 21/D-2 Desensitizer 5/Calcium chloride 0.5%) d = 1.76g/cc	-80	196	.022	943	.002
	-40	358	.032	1207	.005
	73	382	.022	1786	.003
	125	372	.028	1433	.005
	160	149	—	—	—
<u>Composition HBX-3</u> (RDX 31/TNT 28.5/ Al 35/D-2 Desensitizer 5/Calcium chloride 0.5%) d = 1.85g/cc	-80	323	.025	1329	.004
	-40	388	.029	1407	.005
	73	404	.019	2105	.003
	125	402	.026	1750	.005
	160	161	.024	1048	.002
<u>HMX/Kel F</u> (HMX Grade II, Class A 95/ Kel F-800 5%) d = 1.87g/cc	-80	355	.037	1295	.008
	-40	434	.042	1176	.008
	73	613	.065	1126	.018
	125	472	.066	950	.021
	160	300	.060	715	.010
<u>Composition HTA-3</u> (HMX 49/TNT 29/ Al 22%) d = 1.94g/cc	-80	126	.009	1370	.001
	-40	168	.017	1188	.001
	73	269	.016	1752	.002
	125	201	.023	1013	.002
	160	121	.015	1201	.005

(continued)

Table 1 (continuation)

<u>Explosive, Density</u>	<u>Test Temp, °F</u>	<u>Stress at Rupture, psi</u>	<u>Elongation at Rupture, %</u>	<u>Modulus of Elasticity, psi x 10⁻³</u>	<u>Work to Produce Rupture, ft-lb/in³</u>
<u>Composition HTA-4</u>	-80	158	.019	960	.0012
(HMX 38/Al 32/ TNT 30%)	-40	177	.017	1088	.0012
	73	318	.017	1821	.0021
d = 2.00g/cc	125	253	.029	1289	.0034
	160	69	.027	634	.0009
<u>LX-04-1</u>	-80	1450	0.11	1526	.072
(HMX 85/Viton A 15%)	-40	1274	0.26	837	.17
Molded d = 1.87g/cc	73	436	0.36	374	.11
	125	288	0.19	308	.025
	160	227	0.22	170	.022
<u>75/25 Octol</u>	-80	88	.019	445	.0007
(HMX 75/TNT 25%)	-40	81	.014	678	.0005
d = 1.81g/cc	73	146	.010	1565	.0006
	125	113	.015	1548	.0008
	160	120	.018	1102	.001
<u>PBX, Type A</u>	-80	779	.007	1852	.030
(RDX 90/Polystyrene 8.5/Dioctylphthalate 1.5%)	-40	770	.053	2001	.018
	73	627	.035	2065	.009
Molded d = 1.68g/cc	125	700	.14	743	.049
	160	304	.22	266	.028
<u>PBX, Type B</u>	-80	744	.056	1507	.019
(RDX 89.9/Gum Rosin 4.4/Polystyrene and Dye 5.7%)	-40	729	.047	1941	.016
d = 1.68g/cc	73	866	.047	2004	.018
	125	757	.045	1842	.013
	160	642	.038	1936	.011
<u>PBXN-1</u>	-80	873	.049	1816	.019
(RDX 69/Al 20/ Zytel-63 12%)	-40	813	.047	1523	.014
d = 1.78g/cc	73	1230	.067	1913	.035
	125	1087	.084	1371	.048
	160	981	.074	1356	.031
<u>PBXN-3</u>	-80	744	.056	1507	.019
(HMX 85/Zytel-63 15%)	-40	729	.047	1941	.016
Molded d = 1.71g/cc	73	866	.047	2004	.018
	125	757	.045	1842	.013
	160	642	.038	1936	.011
<u>PBX-9404</u>	-80	328	.024	2439	.005
(HMX 94/Tris beta chloroethyl phosphate 3/ NC 2.9/Diphenylamine 0.1%)	-40	620	.036	1960	.010
	73	636	.010	942	.032
	125	326	.012	478	.019
Molded d = 1.84g/cc	160	119	.091	506	.008

(continued)

Table 1 (continuation)

Explosive, Density	Test Temp, °F	Stress at Rupture, psi	Elongation at Rupture, %	Modulus of Elasticity, psi x 10 ⁻³	Work to Produce Rupture, ft-lb/in ³
PBX-9010 (RDX 90/Kel F Elastomer 10%) Molded d = 1.79g/cc	-80	687	.041	2080	.013
	-40	741	.057	1532	.019
	73	387	.158	962	.039
	125	241	.088	552	.012
	160	232	.093	541	.011
RDX-Wax (RDX 86/Wax 14%) d = 1.60g/cc	-80	103	.016	852	.002
	-40	154	.018	1087	.001
	73	363	.040	1172	.007
	125	79	.063	.007	.040
	160	—	—	—	—
TNT d = 1.61g/cc	-80	67	.02	452	.0006
	-40	153	.02	966	.002
	73	120	.03	600	.002
	125	64	.02	446	.0007
	160	61	—	—	—
80/20 Tritonal (TNT 80/Al 20%) d = 1.78g/cc	-80	153	.01	1769	.001
	-40	271	.02	1328	.002
	73	277	.03	1540	.004
	125	177	.045	756	.004
	160	74	—	—	—

Refs 1 and 3 give *dynamic* tensile strength compared to *static* strength (Table 2)

Table 2
Dynamic and Static Tensile Strengths

Explosive	Strain Rate, sec ⁻¹	Ultimate Stress, psi (MPa)	Type of Fracture
LX-04-01 (HMX 85/ Viton A 15%)	10 ⁻⁴	340 (2.34)	Slightly ductile
	850	1500 (10.34)	Slightly ductile
	1100	1780 (12.27)	Slightly ductile
	1550	1750 (12.07)	Brittle
	3100	2100 (14.48)	Slightly ductile
LX-14-0 (HMX 95.5/ Estane 5702-F1, 4.5%)	10 ⁻⁵	450 (3.1)	Brittle
	10 ⁻⁴	540 (3.7)	Brittle
	10 ⁻³	580 (4.0)	Brittle
PBX-9011 (HMX 90/ Estane 5740-X2 10%)	10	340 (2.34)	Slightly ductile
	1050	1300 (8.96)	Brittle
	1100	1450 (10.00)	Brittle
	1300	1400 (9.65)	Brittle

(continued)

X-rays of 10^{-7} secs duration to obtain a series of successive pictures of a jet or collapsing liner. The jet velocity is often in excess of 23000ft/sec. Optical techniques in shaped charge and detonation studies include rotating mirror cameras, Kerr cells, image converter systems, Faraday electro-optical shutters, and ultra high speed framing type cameras. These are all directed to record events in terms of exposure time ranging from 1/10000 to 1/1000000 part of a sec

Whatever the type of weapon considered and whatever the nature of the target attacked, damage can be produced by one or more of the physical phenomena associated with the bringing to rest of a missile, with the detonation of an expl, with nuclear fission, or with chemical or bacteriological action. It is convenient to classify these phenomena as follows: a) fragmentation, or the action of relatively small particles, usually from the case of a bomb, rocket, warhead or shell; b) impact, which pertains to the penetration or perforation of an object by a relatively large metallic body, such as an armor-piercing shot; c) blast, the effect caused by the sudden release of large amounts of energy in a fluid medium; d) debris, set in motion at relatively high velocities; e) heat, in the flame of the blast, or radiant heat; f) fire, which may result from the effects of an expl, or may be induced by special incendiary weapons; g) chemical action, particularly from smoke or poisonous gases; h) bacteriological action; and i) radioactivity

The technical aspects of producing target damage by the many mechanisms described above must include methods or standards by which specific effects on targets can be realized. A target must be considered in terms of its importance to the strategist, the tactician, or the local commander. Its vulnerability may be in terms of personnel, control equipment on the target, a control center or command post, the logistical lines which supply the target, or the economic potential which it supports. Likewise, defensive measures against attack at all levels play a critical role. Target intelligence from the strategic and tactical levels must include details of target vulnerability. Vulnerability studies of friendly and potential enemy weapons are highly scientific processes; for example, aircraft vulnerability studies indicate the best hope of kill against enemy planes, and likewise, indicate the

most vulnerable areas of our own aircraft which can often be minimized by redesign. Armor is evaluated in terms of mobility, armor protection, main weapon accuracy, and tactical employment. Basic data are concurrently fed into computers for playing of mathematical war games

Similarly, the problem of the human target extends far beyond the consideration of the effect of one round delivered against an enemy soldier. Incapacitation of enemy troops requires wound ballistic studies which include vulnerability of the human body; effects of body armor; and armament of friendly troops in terms of weight of principal weapon, weight of ammo carried, weapon accuracy, training time required to reach proficiency with the weapon, and logistical requirements

Refs: 1) Anon, EngrgDesHndbk, "Elements of Terminal Ballistics, Part One, Introduction, Kill Mechanisms and Vulnerability", **AMCP 706-160** (1962) 2) Anon, EngrgDesHndbk, "Elements of Terminal Ballistics, Part Two, Collection and Analysis of Data Concerning Targets", **AMCP 706-161** (1962) 3) Anon, EngrgDesHndbk, "Elements of Armament Engineering, Part Two, Ballistics", **AMCP 706-107** (1963) 4) M.E. Backman, "Terminal Ballistics", Naval Weapons Center **TP 5780** (1976), ADA 021833 5) J.P. Lambert et al, "Standardization of Terminal Ballistics Testing, Data Storage and Retrieval", **ARBRL-TR-02066** (1978), ADE 430062

Terminal Velocity. Drawn to the earth through gravitational attraction, a bomb released from an aircraft falls with an increasing speed. This acceleration due to gravity is retarded by the increasing density of the air as the bomb nears the earth and as velocity increases. The velocity of the bomb increases as it falls earthward, but the acceleration decreases with each second of travel until there is no acceleration and the bomb falls with a constant velocity. This ultimate velocity is known as the *terminal velocity* of the bomb. It is really a function of a given bomb design, dependent upon the aerodynamic characteristics of a bomb, rather than the practical velocity actually obtained, which is called the *impact velocity*

Refs: 1) Ohart (1946), 199 2) Anon, Engrg-

Table 2 (continuation)

Explosive	Strain Rate, sec ⁻¹	Ultimate Stress, psi (MPa)	Type of Fracture
PBX-9404			
(HMX 94/NC (12.0% N) 3/ Tris (β -chloroethyl)- phosphate 3%)	10	330 (2.28)	Slightly ductile
	950	1200 (8.27)	Brittle
	1070	1500 (10.34)	Slightly ductile
	1100	1340 (9.24)	Brittle
	1850	1510 (10.41)	Brittle
PETN			
	10 ⁻³	160 (1.10)	Brittle
	10 ⁻²	215 (1.48)	Brittle
	10 ⁻¹	215 (1.48)	Brittle
	1000	720 (4.96)	Brittle
	1120	700 (4.83)	Brittle
	1300	785 (5.41)	Brittle
	2600	840 (5.79)	Brittle

are helping to increase the knowledge of the subject

Studies previously initiated were intensified during WWII and have been continued for the purpose of having a greater store of technical data pertinent to terminal ballistics. Much of this data relating to the performance of ammo and the vulnerability of targets, has been published (see Refs)

Because terminal ballistic effects ordinarily appear as instantaneous events to the layman, the time factor in terminal ballistic investigations has often been the limiting factor, ie, the ability to physically record detailed reactions which take place during time intervals of the order of several microseconds

Expts are conducted to determine the principles governing the number, size, velocity, and spatial distribution of fragments resulting from detonations of cased HE charges, in order to gain knowledge that will permit optimizing of effects on enemy targets. Thick wall enclosed chambers, instrumented optically and electrically, and lined with thicknesses of materials to trap fragments are basic to these investigations. Penetration effects of small missiles and fragments demand knowledge of air drag parameters of fragments and sub-missiles

Investigations concerning the production and prevention of fire damage to military material must be conducted concurrently. The physical nature of the detonation process within expls involves studies of detonations by various types

of initiators with physical measurements by use of X-ray, electrical and optical techniques. Detonation studies include the mechanism for the formation of air shock from explns

Studies of the propagation and effects of shock waves in earth, rock, air, and other gases under varying conditions are required for the design of blast producing weapons, and for the design of structures capable of withstanding the effects of such weapons. The effects of detonation of small charges under varying conditions are found from actual expts. Extrapolations are made by appropriate scaling laws to obtain effects of full scale weapons. The studies of blast waves extend from the surface of an expl to extended distances, and include studies of effects against personnel, structures, structural members, aircraft, and the air-blast coupling into the ground for relatively long durations. In addition to the timing devices and sensitive pressure pickups, a basic technique involves large shock tubes to reproduce shock wave forms that can be scaled accurately to represent types of shock fronts that result from both conventional and atomic explns

The study of shaped charge and high velocity jets involves investigations in a variety of scientific fields. These include the physics of plasticity of metals at very high strain rates; the physics of interactions between metals and HE's; and the field of instrumentation design for highly specialized applications. Included are multiple flash radiographic techniques which produce

DesHndbk, "Elements of Armament Engineering, Part Two, Ballistics", **AMCP 706-107** (1963), 3-15

Terminalia Chebula. Dried tropical leaf which was patented as an ingredient of perchlorate contg expls. It contains a larger proportion of chebulinic acid than other myrobalans (See Vol 8, M163-L & R). Other ingredients of the expls could include Na nitrate, agar agar, castor oil, colza or rape oil, glycerin, etc
Refs: 1) C.G. Lais, BritP 296794 (1927) & CA 23, 2573 (1929) 2) Ibid, USP 1820000 (1931) & CA 25, 5771 (1931)

Terne Mk 8. Norwegian Navy anti-submarine unguided multiple missile depth charge, powered by two concentric solid-propellant rocket motors. Sonar on ship determines range, bearing and depth of target before Terne is fired; a full salvo of six missiles can be fired in five secs

Terne's warhead is HE, weighing 50kg, with a combined acoustic proximity, impact and time fuse. Its length is 1.95m; body diameter 0.203m; launch wt 135kg; and range approx 3km

Refs: 1) M.J.H. Taylor & J.W.R. Taylor, "Missiles of the World", Charles Scribner's Sons, NY (1976), 147 2) R.T. Pretty, Ed, "Jane's Weapon Systems-1977", Franklin Watts, NY (1976), 123

Terrier. US Navy surface-to-air anti-aircraft missile for shipboard use. The Terrier series of missiles has been operational since 1956, and has been the subject of continued development and improvement. The US military designation is RIM-2 and successive models have been denoted by letter suffixes running from RIM-2A to the latest version, the RIM-2F. The latter is also known as the Advanced Terrier

Beam-rider guidance with semi-active homing is employed to direct the missile against a target designated by the ship's tactical data system. Terrier is launched by a solid fuel rocket booster and propelled by a solid fuel sustainer. The normal warhead is of the HE type with direct action or proximity fuse, but one version of the Terrier (RIM-2D) has been produced with a

nuclear warhead

Range 35km (est); ceiling over 20000m; speed Mach 2.5; overall length 8m; body diameter 30cm; and wt (approx) 1400kg

Ref: R.T. Pretty, Ed, "Jane's Weapon Systems-1977", Franklin Watts, NY (1976), 116

Territ. Swed plastic blasting expl invented by S.A.G. Nauckhoff in 1909 and manufd beginning about 1910 by the Nitroglycerin Aktiebolaget of Stockholm. It consisted of a liq mixt of DNT and TNT 27.8, AP 43, Na nitrate 28, and NC 1.2%; cartridge d 1.67g/cc; Trauzl Pb block test 340cc; vel of deton 4700m/sec. It was comparable to some low-freezing Dynamites in properties and very safe to handle. Its brisance was low so that in coal (or other materials) blasting operations small particulate and dust formation was kept to a minimum

Due to the fact that Territ (as well as other plastic expls) was difficult to detonate, later formulations contained some NG (Ref 4)

Refs: 1) C. Herlin, SS 9, 389-91 & 401-04 (1914) & CA 9, 1116 (1915) 2) Naoúm, Expls (1927), 135 3) Stettbacher (1933), 316 4) R. Meyer, "Explosives", Verlag Chemie, NY (1977), 354

Terrorite. See under "Mindeleff Explosive" in Vol 8, M131-R

Tertiary-Butylhydroperoxide. See in Vol 2, B385-R under "Butylhydroperoxide . . ."

Tertiary-Butyl Peracetate. See in Vol 2, B387-L under "Butyl Peroxyacetate . . ."

Test Papers. See under "Methyl Violet Tests" in Vol 8, M118-L to M120-L, and "Lead Acetate" in Vol 1, A28-R

Testing of Explosives. See under "Explosive and Related Properties Including Tests, of Explosives and Propellants" in Vol 6, E432-L to E439-R; "Bullet Tests" in Vol 2, B332-L to B340-R;

“Detonation (and Explosion), Experimental Procedures” in Vol 4, D299-R to D346-L; “Heat Tests” in Vol 7, H59-R; “Influence Tests” in Vol 7, I98-R to I100-R; “Initiation of Explosion by Impact” in Vol 7, I35-R to I56-L; “Ignition Tests” in Vol 7, I25-L to I30-R; and under the individual expls

Testing Galleries (Versuchsstrecken, Sprengstoffprüfstrecken, Galeries d'essai). See under “Coal Mining Explosives, Testing for Permissibility” in Vol 3, C370-L to C378-L

Addnl Refs: 1) Urbański 3 (1967), 397 & 409–44
2) R. Meyer, “Explosives”, Verlag Chemie (1977), 210

TETA (or Triethylenetetramine). See in Vol 2, B129-L & R under “Bis (aminoethylamino)ethane and Derivatives” and the following
Addnl Ref: H.C. Dehm, “Composite Propellant Including Polyfunctional Amine”, USP 3790416 (1974) & CA 81, 79919 (1974) [The inventor claims a rubbery proplnt contg TETA with mech props at $\sim 40^\circ\text{F}$ and a strain rate of 74/inch/inch/min of: modulus 6300psi, tensile strength 387psi, elongation 37%; at 77°F and 65psi initial stress the creep life is 720 mins. Mfg consists of casting, deaerating and curing for seven days at 180°F a mixt consisting of Cr-2-ethylhexanoate 0.01, carboxy terminated polybutadiene 7.73, diepoxide 0.39, triepoxide 0.06, dioctyladipate 1.91, dioctyl random polyisobutylene polymer 1.91, TETA 0.14, $10\mu\text{Al}$ 5, $200\mu\text{AP}$ 32, $400\mu\text{AP}$ 31 and $100\mu\text{AP}$ 20 wt %]

Tetraacrylonitrile Copper (II) Perchlorate.

$\text{Cu}(\text{C}_3\text{H}_3\text{N})_4(\text{ClO}_4)_2$, $\text{C}_{12}\text{H}_{12}\text{Cl}_2\text{CuN}_4\text{O}_8$; mw 474.732; N 11.80%; OB to CO_2 -74.15%; cryst; loses acrylonitrile in air and absorbs moisture; mp, expl decompn on heating. Prepn is by the reaction of 1.6g of electrolytic Cu with a soln of 6.5g of nitrosyl perchlorate in 100ml of acrylonitrile under N_2 at 15 torr and RT

Refs: 1) Beil, not found 2) Gmelin, not found
3) G. Ondrejovic et al, ChemZesti 18, 281 (1964) & CA 61, 9156 (1964) 4) L. Bretherick, “Hdbk of Reactive Chemical Hazards”, CRC, Cleveland (1975), 593

Tetramminopermanganate, Cadmium.

$\text{Cd}(\text{MnO}_4)_2 \cdot 4\text{NH}_3$; $\text{CdH}_{12}\text{Mn}_2\text{N}_4\text{O}_8$; mw 418.435; N 13.39%; blk cryst turning brn on exposure to air. Prepn is by the reaction of a soln of K permanganate satd with ammonia with a Cd salt. The product explds on impact
Refs: 1) Gmelin, not found 2) Mellor, Vol 12 (1932), 335 3) L. Bretherick, “Hdbk of Reactive Chemical Hazards”, CRC, Cleveland (1975), 627

Tetra-aquoethylenediaminocupric Perchlorate.

See in Vol 6, E235-L & R under “Ethylene-diamine Complexes”

1,3,5,7-Tetrazabicyclo [3.3.1]-Nonane, 3,7-Dinitro. See in Vol 5, E91-R to E93-R under “DPT or DNPT . . . or Dinitropentamethylene-tetramine”

1,3,5,7-Tetraazabicyclo [3.3.1]-Nonane, 3,7-Dinitroso. See in Vol 5, E90-R to E91-R under “Endomethylene-Tetraazocyclooctane and Derivatives”

2,3,7,8-Tetraazaspiro [4.4] Nonane.

$\text{C}_5\text{H}_{12}\text{N}_4$; mw 128.21; N=45.7%; OB to CO_2 -199.67%; flat waxy cryst; mp $140-70^\circ$; d 1.21g/cc at $25/4^\circ$. Sol in dimethylformamide. Prepn is by reacting 2,3,7,8-tetraazaspiro-[4.4] nonane sulfate with ammonia gas at -40° followed by addn of abs ethanol. The mixt is then stirred for 3 hrs at RT and filtered. The solvents are then distld off at 30mm press and $40-50^\circ$ leaving the 95% yield. Neilson claims in his patent applic that the compd is hypergolic with fuming nitric acid, hence useful as a rocket motor fuel

Refs: 1) Beil, not found 2) A.T. Neilson, USP Applic 829761 (1977) (ADD 004343)

2,3,7,8-Tetraazaspiro [4.4] Nona-2,7-Diene.

$\text{C}_5\text{H}_8\text{N}_4$. mw 124.17; N=45.13%; OB to CO_2 -180.40%; feathery prisms; mp $113-19^\circ$; bp (decompn above 150°); d 1.28g/cc at $25/4^\circ$. Sol in chl_f and cyclohexane. Prepn is by reacting

2,3,7,8-tetraazaspiro nonane with mercuric oxide in eth by stirring for 11 hrs under N_2 at RT. The yield is 100%. Neilson claims that the compd is hypergolic with fuming nitric acid, hence useful as a rocket motor fuel

Refs: 1) Beil, not found 2) A.T. Neilson, USP Applic 829761 (1977) (ADD 004343)

2,3,5,6-Tetraazido-1,4-Benzoquinone. See in Vol 2, B80-R and the following *Addnl Ref*: A.H. Blatt & F.C. Whitmore, OSRD 1085 (1942), 79 [Blatt and Whitmore report that the azido-benzoquinone has an OB to CO_2 of -58.8%; an expln temp of 91° ; is expld by the impact of a 0.5-kg Kast app hammer dropped from a height of 20cm; decomps in air forming a yel-grn powder which when touched with a flame, ignites but does not deton as does the original compd]

3,4,5,6-Tetraazido-1,2-Benzoquinone. See in Vol 2, B80-R

Tetraazido-4,4-Diphenoquinone. See in Vol 5, D1414-L

2,4,6,8-Tetrabromo-1,5-Dinitramino-Anthraquinone. $O_2N.HN.C_6HBr_2(CO)_2.C_6HBr_2.NH.NO_2$, rearranges to become $HO.(O):N:N.C_6HBr_2.(CO)_2.C_6HBr_2.N:N(O).OH$; mw 648.82; N 8.70%; OB to CO_2 -49.70%; rhombic platelets; mp, deflagrates at 166° . V sol in dil aq Na hydroxide; sl sol in ammonia; insol in most org solvents. Prepn is by nitration of 2,4,6,8-tetrabromo-1,5-diaminoanthraquinone with colorl nitric acid (d 1.52g/cc) in the cold (using an ice-salt mixt for cooling

Ref: Beil 16, 680

3,3',5,5'-Tetrabromo-4,4'-Dinitramino Benzalazine (Azine). $[O_2N_2H.C_6H_2Br_2.CH:N]_2$; mw 643.88; N 13.06%; OB to CO_2 -69.58%; colorl ndles (from ethanol); mp, explds when heated. Prepn is by diazotization and reduction of 3,5-dibromo-4-aminobenzaldehyde (Ref 2) followed by nitration (Ref 3)

Refs: 1) Beil 16, [348] 2) O. deWitt, Ber 42, 2953-61 (1909) & CA, not found 3) L. Elion, Rec 42, 159-60 (1923) & CA 19, 2193 (1925)

N,N,N',N'-Tetrabutylethylenediamine Dipchlorate. $(C_4H_9)_2NCH_2CH_2N(C_4H_9)_2$. $2HClO_4$; $C_{18}H_{42}Cl_2N_2O_8$; mw 475.37; OB to CO_2 -164.9%; cryst solid; mp $183-85^\circ$. Its impact sensy using the PicArsn app with a 2-kg wt was found to be over 100 inches for at least one expln in ten tries. A stoichiometric soln in 100% nitric acid (storage stab at $200^\circ F$, 2.0 hrs) has been patented as a monopropellant

Refs: 1) Beil, not found 2) R.C. Doss, USP 3031838 (1962) & CA 57, 7508 (1962)

Tetracene. See under "Guanylnitrosaminoguanyl Tetrazene" in Vol 6, G169-L to G172-R, and "Tetracene Salts" on G172-R

N,N,N',N'-Tetrachloroadipamide (N,N,N',N'-Tetrachlorohexanedioic acid diamide). $Cl_2NCO(CH_2)_4CONCl_2$; mw 282.97. Sol in acet; not sol in w. Prepn is by passing Cl_2 thru a mixt of adipic amide and Na bicarbonate in w for 2 hrs at 0° . The prod is dissolved in acet and pptd by cold w. It is decompd by boiling w to yield a v expl (yel) oil which is either the di- or trichloroamine

Refs: 1) Beil, not found 2) P. Eckert et al, ReyonSyntheticaZellevolle 29, 2-8 (1951) & CA 45, 7527 (1951)

Tetraethanol Ammonium Pentanitrate (Tetra-(β -Hydroxyethyl) ammonium pentanitrate). $(O_2N.O.CH_2CH_2)_4N.O.NO_2$; mw 436.30; N 19.27%; OB to CO_2 -33.00%. Prepn is by nitrating $(OHC_2H_4)_4NOH$ (or its salts) at temps of from 20 to 60° . Ref 2 recommends its usage as an expl which is less sensitive to w than the tetranitrate obtd from $(OHC_2H_4)_3N$

Refs: 1) Beil, not found 2) E. VonHerz, GerP 630079 (1936) & CA 30, 5794 (1936) 3) Blatt, OSRD 1085 (1942), 79

Tetraethylammonium Nitrate. $(C_2H_5)_4N.NO_3$; mw 192.26; N 14.57%; cryst; mp $> 200^\circ$, 280° (decompn); d 1.1622g/cc at $25/4^\circ$. Sol in chl_f and methylene chloride. Prepn is by treating tetraethylammonium hydroxide with dil nitric acid (Ref 3)

Refs: 1) Beil 4, (350), [597] & {201} 2) S.D. Ross & M.M. Labes, JACS 79, 4155-59 (1957) & CA 52, 1048 (1958) 3) Private communication between O. Sheffield & S. Helf, PicArns, Dover (11 Nov 1960)

Tetraethylenepentamine Perchlorate (TEPAP). $C_8H_{19}N_5Cl_4O_{16}$; mw 583.12; N 12.01%; OB to CO_2 -23.32%; cryst; mp, fuses ca 65° . Prepn is by cautious addn of 70% perchloric acid to a methanol soln of tetraethylenepentamine. Wyandotte proposed that it be used as a proplnt (Ref 2)

Refs: 1) Beil, not found 2) C.T. Lenk et al, "Studies on the Preparation of Aminoethyl Cellulose Perchlorate and Other Fast Burning Propellants", Summary Rept 3, Wyandotte Chemicals Corp (1957), 18-19

N,N,N',N'-Tetraethylethylenediamine Dipchlorate. $(C_2H_5)_2NCH_2CH_2N(C_2H_5)_2 \cdot 2HClO_4$; $C_{10}H_{26}Cl_2N_2O_8$; mw 373.24, OB to CO_2 -107.2%; cryst solid; mp $166-68^\circ$. Its impact sensy using the PicArns app with a 2-kg wt was found to be 40 inches for at least one expln in 40 tries. A stoichiometric soln in 100% nitric acid (storage stab at $200^\circ F$, 6.5 hrs) has been patented as a monopropnt

Refs: 1) Beil, not found 2) R.C. Doss, USP 3031838 (1962) & CA 57, 7508 (1962)

Tetraethylozonide. See under "Ethylozonide" in Vol 8, O70-L

Tetraethynylgermanium. $Ge(C\equiv CH)_4$; mw 172.71; mp $91-92^\circ$ (subl); lt pink cryst. Sol in pentane and hexane-benz mixt. Prepn is by the addn of Ge tetrachloride to an anhydr tetrahydrofuran soln of mono-Na acetylde, and refluxing the mixt for 15-30 mins. The yield after recrystn (caution) is 34%. The acetylde

explds on rapid heating or friction

Refs: 1) Beil, not found 1a) Gmelin, not found 2) W. Davidsohn & M.C. Henry, JOrgmetChem 5, 29 (1966) & CA 64, 3593 (1966) 3) T.F. Rutledge, "Acetylenic Compounds . . .", Reinhold, NY (1968), 108

Tetrafluorohydrazine. See in Vol 6, F148-L & R and the following *Addnl Refs*: 1) R.E. Lide, "Scale-Up of New Process for Production of Tetrafluorohydrazine (U)", Report No S-106, Rohm & Haas Co, Huntsville, Contract No DA-01-021-AMC-13864 (Z) (1967). [A continuous process for the production of N_2F_4 is reported. The process involves the oxidn of HNF_2 by aq ferric ions at pressures of from 5 to 15psig and at temps of 70 to $220^\circ F$. Pilot plant production rates of 1.8 lbs/hr of 98.5% pure N_2F_4 were obtd] 1a) S.F. Reed, Jr, "Difluoramino Glycols Useful as High-Energy Binders for Propellants or Explosives", USP 3346643 (1967) & CA 67, 118753 (1967) [The inventor claims that by using N_2F_4 to treat substituted 1,3-dioxolanes, an adduct is formed which can be hydrolyzed to yield difluoramino glycols which can then be further treated to form high energy binders for proplnt or expl grains] 2) L.P. Kuhn & C.R. Wellman, "Explosive Reactions of N-F Compounds with Hydrogen", BRL 1431 (1969) [The authors report that one p of tetramethylethylene in 10000p of reaction mixt is sufficient to suppress the expl reaction between Tetrafluorohydrazine and H_2]

Tetrahydrofuran and Derivatives

Tetrahydrofuran (THF). See in Vol 2, B382-R under "Butylene Oxides, . . . or Tetramethylene Oxide" and the following *Addnl Refs*: 1) H. Rein, AngChem 62, 120 (1950); R. Criegee, Ibid & CA 44, 6129 (1950) [Presented are reports on the formation of an expl peroxide from THF. Criegee suggests that on standing or heating a highly expl alkyl peroxide is formed] 2) L. Bretherick, "Handbook of Reactive Chemical Hazards", CRC, Cleveland (1975), 409-10 [A bibliography of articles concerning the formation of expl peroxides from and the handling of

THF is presented with brief abstracting; “. . . The latest publication recommends the use of cuprous chloride for removal of trace quantities of peroxides. If more than trace quantities are present, the peroxydisolved solvent should be discarded by dilution and flushing away with water . . . The use of lithium tetrahydroaluminate is only recommended for drying tetrahydrofuran which is peroxide-free and not grossly wet . . .” THF peroxide will detonate on reaction with Na or K hydroxide] 3) Merck (1976), 1187 (No 8929) [CA Registry No [109-99-9]] 4) Anon, C&EN 56 (6), 3 (1978) [Expln on refluxing of THF with Ca hydride]

3,4-Dinitroxy Tetrahydrofuran (or Dinitroxy butylene oxide). See in Vol 5, E123-L under “Erythranediol Dinitrate”

1,4,5,6-Tetrahydro-6-Oxopyridazinecarbonyl Azide. $C_5H_5N_5O_2$; mw 167.15; N 41.91% OB to CO_2 -100.51%; mp 135° (with expln). Prepn is by treating the ethyl ester of 3-carboxy-4,5-dihydro-6(1H)-pyridazinone hydrazide hydrochloride with Na azide (Curtius reaction) Refs: 1) Beil, not found 2) H. Gault et al, BullFr 1954, 916-18 & CA 49, 12482(1955)

1,1,4,4-Tetrahydroperoxycyclohexane Tetraacetate. $C_{18}H_{28}O_{12}$; mw 436.46; OB to CO_2 -139.30%; rhombic plates (from ethanol); mp $144-45^\circ$ (decompn, then deton). Prepn is by reacting (caution) cyclodecandione (tetra) peroxide with ethanoyl chloride. The peroxy ester explodes on gentle rubbing Refs: 1) Beil, not found 2) R. Criegee & H. Dietrich, Ann 560, 135-41 (1948) & CA 43, 6189 (1949)

Tetrahydropyrimidine, 2-Nitrimino-5-Nitroxy. $C_3H_5N_4O_2$; mw 129.12, N 43.40%; OB to CO_2 -80.55%; micaceous cryst; mp 218° (decompn); RI 1.508. Prepn is by nitrating 2-imino-5-hydroxytetrahydropyrimidium ethyl sulfate with mixed acid for 2 hrs with stirring at $0-20^\circ$. After pptn by pouring on cracked ice, the prod is recryst from hot w. The inventors (Ref 2) suggest using the compd to replace NGu in

“cool” proplnts to aid burning, ignition and to reduce the size of cryst complexes Refs: 1) Beil, not found 2) J.A. Gallagher & R. Evans, USP 2994695 (1955) & CA 56, 2461 (1962)

Tetrahydroxybiphenyl, Hexanitro. See under “Hexanitrobiresorcinol” in Vol 2, B127-L

Tetrahydroxybiphenyl, Tetranitro. See under “Tetranitrobiresorcinol” in Vol 2, B127-L

1,2,5,6-Tetrakis (Difluoroamino)-3,4-Hexanediol Dinitrate. $C_6H_8F_8N_6O_6$; mw 412.20; N=20.39%; OB to CO_2 -38.82%; yel visc oil; bp, decompn at 155° . Sol in chl. Prepn is by nitration of 1,2,4,6-tetrakis (difluoroamino)-3,4-hexanediol in chl with mixed acid (50/50) at below 25° . After 6 hrs of stirring the mixt is poured over ice and the chl layer evapd leaving the prod. The inventor claims the compd is useful as an expl and rocket proplnt Ref: R.A. Smiley, “1,2,5,6-Tetrakis (Difluoroamino)-3,4-Hexanediol Dinitrate Rocket Propellant and Explosive”, USP 3331867 (1967) & CA 67, 75036 (1967)

Tetrakis (Nitraminomethyl) methane. See in Vol 8, P126-R to P127-L under “Pentaerythrityl-tetrakis (nitramine) . . . PETX”

Tetralin Hydroperoxide. See in Vol 8, P207-L under “1,2,3,4-Tetrahydro-1-Naphthyl Hydroperoxide” and the following Addnl Refs: J.S. McDonald & J.S. Owens, “Investigation of Tetralin Explosion”, NAA-SR-4803, Atomic Intrnl, Canoga Park, Contract AT (11-1)-GEN-8 (1960) [An expln in a Na-tetralin heat exchanger is reported as being caused by the unforeseen formation of α -tetralin hydroperoxide. The $Q_{decompn}$ of the hydroperoxide to α -tetralone or α -tetrol is calcd as being 70 and 67kcal/mole, respectively

Tetralin, 5-Nitro (5-Nitro-1,2,3,4-Tetrahydro-

naphthalene). $C_{10}H_{11}NO_2$; mw 177.12; N 7.91%; OB to CO_2 -212.29%; cryst (from methanol); mp 34° ; bp 157° at 13mm; d 1.175 g/cc at 40/40°. Prepn is by nitration of tetralin with a mixt of nitric (d 1.35g/cc) and sulfuric (d 1.84g/cc) acids at 0° . Blatt (Ref 2) terms the power and brisance of this expl as less than PA

Tetralin, 6-Nitro (6-Nitro-1,2,3,4-Tetrahydronaphthalene). This expl is obtained in mixt with the 5-Nitro compd (above). Its differing characteristics are: mp 31.4° ; bp 169° at 13mm; and d 1.1762g/cc at 40/40°
Refs: 1) Beil 5, (238) 2) Blatt, OSRD 1085 (1942), 70

Tetralina. Span for Tetranitroaniline (TeNA). See in Vol 1, A411-L to A413-R

Tetralita. Span for Tetryl. See in this Vol under "Spanish Explosives and Ammunition" and "Tetryl"

Tetralita No's 1 and 2. Span military expls. See in Vol 5, D1316-L & R

Tetralite. Ital for Tetryl. See in Vol 7, I179-L and in this Vol under "Tetryl"

Tetramethoxydiphenyl, Hexanitro (Tetramethyl-ether). $(CH_3O)_2C_6(NO_2)_3 \cdot C_6(NO_2)_3(OCH_3)_2$; mw 544.34; N 15.44%; OB to CO_2 -64.67%; brt

yel ndles (from ethanol); mp 208° . V sol in benz, sl sol in eth; insol in w. Prepn is by reacting one mole of hexanitroresorcinol with four moles of diazomethane in eth. Tetramethyl-ether deflgr when heated rapidly
Ref: Beil 6, (575)

Tetramethylammonium Azidodithiocarbonate. See in Vol 1, A637-R

Tetramethylammonium Chlorate. $(CH_3)_4N^+ \cdot ClO_3^-$; mw 157.62; N 8.89%; OB to CO_2 -60.91%; white cryst. V sol in ethanol and w. Prepn is by double decompn between tetramethylammonium-iodide and Ag chlorate followed by evapn of the resulting soln on a w bath to crystn. The chlorate explds at 230°
Refs: 1) Beil 4, (326) & {112} 2) R.L. Datta & J.K. Choudhury, JACS 38, 1079-86 (1916) & CA 10, 1749 (1916)

Tetramethylammonium Chlorite. $(CH_3)_4N^+ \cdot ClO_2^-$; mw 141.62; N 9.89%; OB to CO_2 -135.57%; colorl cryst. Sol in w. Prepn is by reaction of equimolar amts of tetramethyl sulfate and Ba chlorite with subsequent vac evapn of the resulting soln to crystn. The Chlorite explds on impact
Refs: 1) Beil 4, [558] 2) G.R. Levi, Gazz 52, I, 207-09 (1922) & CA 16, 2474 (1922)

Tetramethylammonium Hydrotriborate. $(CH_3)_4N \cdot B_3H_8$; mw 114.64; N 12.2%; tetr wh

Table 1
Comparison of a Standard NH_4ClO_4 Double-base Propellant
With a Similar Experimental Propellant Containing Tetramethylammonium Hydrotriborate

NH_4ClO_4 , wt %	Double Base, wt %	Al, wt %	$(CH_3)_4NB_3H_8$, wt %	d, g/cc	I_{sp} , sec	T_c^a , °K	T_e^b , °K
28.0	50.00	22.00	0	1.797	263	3770	—
26.53	50.00	20.47	3	1.718	264	3490	2274
27.23	50.00	17.77	5	1.663	264	3291	1977
29.00	50.00	11.00	10	1.540	257	2748	1508

a — chamber temp

b — exhaust temp

cryst; mp, not observed from 25 to 300°; d 0.778g/cc(X-ray), 0.312g/cc (bulk). Sol in liq ammonia, acetonitrile, methanol and w; sl sol in ethylenediamine and unsym DMH; insol in diethylamine. Prepn (from Refs 2 & 3 in a manner analogous to the prepn of borine trimethyl-amine) is by the reaction of tetramethylammonium chloride with an ethereal soln of LiB tetrahydride at RT, followed by distlg off the solvent and vac subliming the prod into a cooled receiver. The triborate has a compressive strength of 1700psi at RT; a Q_f of -35kcal/mole; an ign temp of 280° (30 secs), 330° (5 secs); an impact sensy of 40" using a 2-kg wt in a PicArSn app; a vac stab of no gas evoln below 170°, and H₂ evolved at 210°

The compd is suggested by Callory Chemical Co (Ref 3) as an additive to proplnt formulations where it lowers the chamber temp without loss in I_{sp} . An example of such usage is shown in Table 1

Refs: 1) Beil, not found 2) G. Brauer, Ed, "Handbook of Preparative Inorganic Chemistry", Vol 1, 2nd Edn, Academic Press, NY (1963), 778 3) Anon, "Tetramethylammonium Hydrotriborate (QMP-3) (U)", No 01516, Callery Chem Co, Callery, Contract NOW 64-0243-d (1964)

Tetramethylammonium Nitrate and Derivatives

Tetramethylammonium Nitrate (Nitetra, TeMeAN or Tetra-Salz (Ger)). (CH₃)₄N.O.NO₂; C₄H₁₂N₂O₃; mw 136.2; N 20.57%; OB to CO₂ -129.22%; white or colorl crystals; mp 325-28° (Ger sources), 405-10° (Fr sources); d 1.25 g/cc, 0.70g/cc (bulk). Sol in hot w; sl sol in cold w. Not an expl by itself, TeMeAN forms powerful expls, acting as a fuel when mixed with oxygen carriers such as nitrates (see below). It was produced in Ger in the last part of WWII, where it was used as an expl "extender" when the shortage of other expls (such as RDX, TNT, etc) became very acute. Two methods were used for its manuf (see below), one consisted of the interaction of methyl nitrate with trimethylamine (which was obtd together with monomethylamine in the manuf of dimethylamine), and the other method was the interaction of am-

monia and methyl nitrate. In the latter method the Tetra-Salz product is impure, containing some monomethylammonium nitrate and AN. This mixt could be used per se as an expl because it contains some amt of an O carrier, obviating the necessity for purification

Prepn by the First Method: A satd aq soln of pure TeMeAN is pumped into a stainless steel reactor equipped with a stirrer, cooling jacket and large diam inlet and outlet pipes. Gaseous trimethylamine and methyl nitrate (free from methanol) are then fed by separate inlet pipes into the reactor as its contents are efficiently stirred and cooled. The newly formed TeMeAN is immediately pptd and the resulting slurry is drawn off either batchwise or in a semi-continuous fashion. As the slurry is drawn off it is cooled and run into a rotary vac filter. After washing the solid product with a limited amt of w, it is dried in a vac on steam heated perforated shelves and removed. The mother liquor, consisting of a satd aq soln of TeMeAN and traces of impurities, is recycled 10-15 times. After the recycling phase the liquor is concd so as to ppt the bulk of the TeMeAN, again leaving the impurities in the concd mother liquor. The procedure is concluded by purifying the crude TeMeAN by means of recrystn. The waste mother liquor is either discarded or used as fertilizer and a new satd recycling soln is made from the pure TeMeAN product

Prepn by the Second Method: A concd aq ammonia soln (equiv to 136kg of 100% NH₃) is fed into a steam-heated jacketed stainless steel lined vessel (3-4m³ in vol and covered). After starting the stirrer, methyl nitrate (free of methanol) and gaseous ammonia are fed into the reactor. During this phase of the procedure the reaction vessel is closed so as to maintain the slightly increased press necessary to accelerate the conversion. Excess pressure is regulated by means of a safety valve equipped reflux condenser. Pressure is further regulated by control of the amts of reactants added to the mixt and maintenance of reaction temp at 40°. When the addn of the reactant is complete (616kg of methyl nitrate and 136kg of ammonia), the temp is allowed to increase to the bp of the mixt. The mixt is allowed to boil for 4-6 hrs so as to insure completion of the conversion of the reactants. The excess ammonia is then removed by

distln. This procedure can be used directly to prepare expl mixts for shell loading by the addn at this point of Na nitrate, RDX and powdered Al (Ref 3)

TeMeAN has the following expl properties as detd by LeRoux (Ref 4) except where noted: *Booster sensy.* When packed in a steel tube 30mm in diam and 17cm long, with walls of 1.5mm in thickness and initiated by means of a blasting cap and a 50g booster (consisting of PETN/MNN-95/5 at a d of 1.60g/cc), the deton extended 5-6cm (ref AN, 8-9cm)

Compressibility.

Pressure, kg/cc 68 170 270 850 3400
d, g/cc 0.90 1.17 1.20 1.21 1.22

Flammability. When placed in a 20mm x 1 m trough the material ignited after 50-60 secs exposure to an open flame and contd to burn for a half an hour with an orange flame until consumed

Heat of Combustion. Q_v^c , 707.2kcal/mole at 18° (using the diamond and liq w as refs)

Heat of Formation. F_v , 75.8kcal/mole at 18°; F_p , 80.8kcal/mole at 18° (using the diamond and liq w as refs) (Ref 5); ΔH_f , -607.4kcal/kg (Ref 7)

Hygroscopicity. Less than AN; however, mixts of 20/80p TeMeAN/AN proved to be more hygr than AN

Impact Sensy. No explns were produced at 3m when a 10-kg wt was used to impact encapsulated samples

Power by Trauzl Test (CUP). LeRoux reports that when used alone TeMeAN could *not* be detonated, but its 50/50 mixt with RDX gave a value of 96cc vs 100cc for PA. From this data he calcd a CUP value of 56

Sensy to Initiation by Thermal Means. When 0.1g of TeMeAN was heated in a test tube from 250° at a rate of 5°/min, the color changed to lt brn ca 400°. At 410° white smoke appeared and the material melted to a blackish liq. A fresh sample immersed in a metallic bath at 370° evolved nitrous fumes in 2 mins and gradually turned black

Toxicity. According to Römer and Walter et al (Refs 2 & 3), TeMeAN and its expl compns are not toxic, nor are they irritating to the eyes, skin or lungs. It can be disposed of by aq soln, filtering off of other expl constituents (if present), and using the soln as a fertilizer

The following information on expl compns contg AN as reported by LeRoux are shown in Tables 1 and 2

Table 1
Melting Points of Various Mixtures of TeMeAN with AN

TeMeAN, %	0	10	18	25	29	32	40
Mp, °C	169	156	146	137	150	158	>170

Table 2
Explosive Parameters of
Mixtures of TeMeAN with AN and RDX

TeMeAN, %	13.4	11.7 (and 13% RDX)
AN, %	86.6	75.3
Initiation Sensy, g MF	1.5	0.5
d, g/cc		
(Packing)	0.90	1.00
(Max)	1.60	1.40
Gap Test, cm	1.5	4.5
Trauzl Test, (PA=100), cc	112.5	119.5
Deton Vel, m/sec	3130 at d 0.90g/cc	4550 at d 1.30g/cc
Impact Sensy using 10-kg wt	at 3m- 40% expls	at 2m- 52% expls
Flammability	Hard to ignite; burns only when flame is applied	S1 easier to ignite

According to Römer (Ref 2) the following expl mixt is superior to PETN: TeMeAN 8, AN 52, Na nitrate 8, Ca nitrate 7, and RDX 25%. Its reported parameters consist of a casting temp of 112°, cast d of 1.50g/cc, and a fragmentation diameter of 41m vs 40m for TNT. The following expl mixts are reported by Walter et al (Ref 3) as being more powerful than TNT, thermally stable, much less hygr than AN, and cast-loadable at temps between 80-100° (Table 3)

Although TeMeAN is essentially neutral (with an aq soln pH of between 7.0-7.1) it is not compatible with TNT. For this reason TNT cannot be included with it in expl mixts. Indeed, when TNT is *gently* heated with TeMeAN the

Table 3
Explosive Compositions Containing TeMeAN,
AN and Na Nitrate (with RDX or PETN added)

Compn, %			
TeMeAN	19.5	13.4	15.1
AN	80.5	86.6	75.3
NaNO ₃	—	—	9.6

Footnote to Table 3: By adding about 15% of PETN or RDX, expls with deton vels of ca 6700 m/sec are obtd with a Q_e range of 1000 to 1050 kcal/g and a gas vol on deton of 970ℓ/kg

mixt turns red and undergoes violent decompn (Refs 2 & 3). However, despite this disadvantage, it is to be pointed out that when TeMeAN is prepd by "the Second Method" (above), a mixt with methyl amine nitrate and AN is obtained which in itself is an expl. Its properties can be improved by incorporating an addnl quantity of AN. By also incorporating Al into such mixts (in a not too finely divided state) in amts of up to 40%, an Ammonal type expl may be obtained. These expls are not very brisant and do not develop high deton vels, but they produce a secondary blast which is a true gas expln. Therefore, projectiles loaded with these Ammonal type expls were found to be useful for destroying larger targets, such as huts, houses, etc. They were also found to be effective against aircraft. It was also found that mixts of TeMeAN, methylamine nitrate and AN could be used for rapid production of foxholes or tank traps. For these purposes these mixts were loaded in paraffin impregnated wooden boxes and placed in desired positions directly on the ground. After covering the box with some earth (mudcapping method), the charge was expld, thus producing the desired crater (Ref 3)

The use of TeMeAN in proplnts is reported by Walter et al (Ref 3) as follows: Prepn consists of dissolving 19.5p of TeMeAN and 80.5p of AN in a small quantity of w. The soln is then evapd in a porcelain dish and melted. The melt is poured in a thin layer on an Al sheet where it solidifies. The resulting flakes are then crushed, ground, sifted and then compressed into cylinders of a desired diam/length ratio. When tested as proplnts in guns, these grains proved to be

ballistically as satisfactory as any single or double-base proplnt. Since it was found that the erosion produced by the TeMeAN proplnts was very small, the Germans proposed to use them in long-barreled naval guns and in antiaircraft arty. For large caliber guns, it was proposed that the proplnt compns be pressed into hexagonal prisms with axial perforations so as to increase the burning rate. To provide moisture protection a collodion coating was suggested. The TeMeAN proplnts produced proved to be more stable than NC, NC-NG, or NC-DEGDN powders. It was found that their burning rate obeys Berthelot's Law, ie: proportional to pressure. It was also found that TeMeAN proplnt mixts could be compressed into grains which are absolutely homogeneous, containing no pores or cracks (major causes of proplnt grain deton), thus providing an excellent group of solid proplnts for small and medium sized rockets

Walter et al (Ref 3) further reports the existence of **TeMeAN Perchlorate** (see below), which may be useful in *pyrots*. One method of prepn is by reacting TeMeAN with perchloric acid. The perchlorate is sl sol in w. It is considered to be not as sensitive as methylamine nitrate perchlorate. When ignited, the TeMeAN Perchlorate burns with a small bluish-white, sparkling flame

Refs: 1) Beil 4, 52, (326), [559] & {113} 2) G. Römer, "Report on Explosives", PBL Rept 85160 (1946), 24 3) H. Walter et al, "German Developments in High Explosives", FIAT Final Report 1035, or PB Rept 78271 (1947), 19-24 4) A. LeRoux, MP 35, 121-32 (1953) & CA 49, 5842 (1955) 5) L. Médard & M. Thomas, "Heats of Combustion for Twenty-Four Explosive Substances", MP 36, 97-127 (1954) & CA 50, 3763 (1956) 6) R. Meyer, "Explosivstoffe", Verlag Chemie, Weinheim (1975), 234 7) R. Meyer, "Explosives", Verlag Chemie, NY (1977), 258

Tetramethylammonium Dinitrate (TeMeADN or Tetra-Di-Salz (Ger)). $(\text{CH}_3)_4\text{N.O.NO}_2.\text{HNO}_3$; mw 199.20; N 42.20%; OB to CO₂ -68.27%; white cryst; mp, ca 126° (decompn to TeMeAN and nitric acid). Sl sol in w. There are two methods of prepn: 1) By boiling under reflux a soln of TeMeAN in a stoichiometric quantity of

60% nitric acid ($d=1.42\text{g/cc}$) and evap off the w under vac, or 2) by dissolving TeMeAN in hot nitric acid ($d=1.42\text{g/cc}$), then cooling the soln, separating the crstn ppt by filtration, washing the ppt with a small quan of w, and drying the ppt under vac at $60-70^\circ$

Mixts of TeMeADN with AN are considered suitable as *expls* by Walter et al (Ref 3). As an example, a compn contg TeMeADN 70 and AN 30% melts ca 88° and, if about 5% powd RDX is incorporated into the melt, forms a powerful expl quite suitable for filling shells. However, in order to prevent the corrosion of the shell from any nitric acid released by the compn, it is recommended that the interior of the shell be coated with acid resistant paint (such as an asphalt lacquer). This expl proved to be more brisant than TNT, as indicated by Kast test results of crushing a 10mm high Cu cylinder 8.5mm vs 6.3mm for TNT. The compn has a deton vel of 7000m/sec, a Q_e of 1200–1220 kcal/g (1500 for NG), an impact sensy rating of "insensitive", and a gas vol evolved on deton of 900l/kg

Refs: 1) Beil 4, (326) 2) G. Römer, "Report on Explosives", PBL Rept 85160 (1946), 24 3) H. Walter et al, "German Developments in High Explosives", FIAT Final Report 1035, or PB Rept 78271 (1947), 19–24

Tetramethylammonium Perchlorate. $(\text{CH}_3)_4\text{N}^+\cdot\text{ClO}_4^-$
 $\text{C}_4\text{H}_{12}\text{ClNO}_4$; mw 173.60; OB to CO_2 –92.2%; tetragonal crysts (Refs 1 & 4a); decomp above 300° without melting, explds on strong heating (Ref 2). Sl sol in cold w; moderately sol in chl, benz, methyl alc, ethyl alc, acet, and ethyl acetate (Ref 4). CA Registry No [2537-36-2]

It is best prepd by the addn of an excess of perchloric ac to an aq soln of tetramethylammonium sulfate, followed by evapn of the soln until crysts appear (Ref 3)

Its impact sensy is 48% of PA; power and brisance less than PA (Ref 5). The compressed salt failed to burn at all pressures between 1 and 400 atm (Ref 6)

Refs: 1) Beil 4, 52, (326), [558] & [112] 2) K.A. Hofmann et al, Ber 43, 2626 (1910) 3) J. Milbauer, JPraktChem 87, 397 (1913) & CA 7, 2544 (1913) 4) P. Walden et al, ZPhysik-Chem 123, 429 (1926) & CA 21, 1396 (1927)

4a) K. Herrmann & W. Ilge, ZKrist 71, 47–63 (1929) & CA 23, 5372 (1929) 5) Blatt, OSRD 2014 (1944) 6) A.E. Fogel'zang et al, Fiz-GoreniyaVzryva 8, 257 (1972) & CA 78, 45833 (1973)

Tetramethylammonium Permanganate. $(\text{CH}_3)_4\text{N}^+\cdot\text{MnO}_4^-$;
 mw 192.57; N 7.28%; OB to CO_2 –83.09%; violet tetragonal crysts; mp, explds when heated; d 1.541g/cc. It is decompd by moist air
Refs: 1) Beil 4, 52, (326) & [559] 2) K. Herrmann & W. Ilge, ZKrist 71, 4763 (1929) & CA 23, 5372 (1929)

Tetramethylazobenzene. See under "Azoxy-ylene" in Vol 1, A662-L

Tetramethylazoxybenzene. See under "Azoxy-ylene" in Vol 1, A673-L

N,N,N',N'-Tetramethyl-1,3-butanediamine Diperchlorate. $(\text{CH}_3)_2\text{NCH}_2\text{CH}_2\cdot\text{CHN}(\text{CH}_3)_2\cdot 2\text{HClO}_4$;
 $\text{C}_8\text{H}_{22}\text{Cl}_2\text{N}_2\text{O}_8$; mw 345.19; OB to CO_2 –88.1%; cryst solid; mp $296-98^\circ$

Its impact sensy using the PicArns app with a 2-kg wt was found to be 24" for at least one expln in ten tries. A stoichiometric soln in 100% nitric acid has a flash pt $<-80^\circ$, it shows a storage stability at 200°F of 9.5 hrs. The Dipperchlorate has been patented as a monopropnt
Refs: 1) Beil, not found 2) R.C. Doss, USP 3031838 (1962) & CA 57, 7508 (1962)

N,N,N',N'-Tetramethyl-2-butene-1,4-diamine Dipperchlorate. $(\text{CH}_3)_2\text{NCH}_2\text{CH}:\text{CHCH}_2\text{N}(\text{CH}_3)_2\cdot 2\text{HClO}_4$; $\text{C}_8\text{H}_{20}\text{Cl}_2\text{N}_2\text{O}_8$; mw 343.17, OB to CO_2 –83.9%; cryst solid, mp $193-95^\circ$

Its impact sensy using the PicArns app with a 2-kg wt was found to be 12" for at least one expln in ten tries. A stoichiometric soln in 100% nitric acid (storage stab at 200°F , 29.2 hrs; I_{sp} at 20 atm, 222.3 secs) has been patented as a monopropnt
Refs: 1) Beil, not found 2) R.C. Doss, USP 3031838 (1962) & CA 57, 7508 (1962)

1,1,4,4-Tetramethyl-2-Butynylene-Dihydroperoxide. See under "Acetylene dihydroperoxides" in Vol 1, A66-R

N,N,N',N'-Tetramethyldecanediamine Diperchlorate. $(\text{CH}_3)_2\text{N}(\text{CH}_2)_{10}\text{N}(\text{CH}_3)_2 \cdot 2\text{HClO}_4$; $\text{C}_{14}\text{H}_{34}\text{Cl}_2\text{N}_2\text{O}_8$; mw 425.29; OB to CO_2 -139.2%; cryst solid; mp 94-96°

Its impact sensy using the PicArns app with a 2-kg wt was 92" for at least one expln in ten tries. A stoichiometric soln in 100% nitric acid (flash pt < -72°; storage stability at 200°F, 7.2 hrs) has been patented as a monopropnt
Refs: 1) Beil, not found 2) R.C. Doss, USP 3031838 (1962) & CA 57, 7508 (1962)

Tetramethyldiaminobenzene (Tetramethylphenylenediamine). See under "Diaminotetramethylbenzene and Derivatives" in Vol 5, D1144-L

Tetramethylenediamine Diperchlorate (1,4-Butanediamine Diperchlorate). $\text{H}_2\text{N}(\text{CH}_2)_4\text{NH}_2 \cdot 2\text{HClO}_4$; $\text{C}_4\text{H}_{14}\text{Cl}_2\text{N}_2\text{O}_8$; mw 289.07; OB to CO_2 -38.7%; cryst solid; CA Registry No [24827-79-0]

Samples were packed into tubes, ignited, and the change of burning rate with press measured. The following results were obtained:

Press in Atm	Equation for the Change of Burning Rate with Press
1-21	$u = 0.24p^{0.7}$ cm/sec
21-37	$u = 0.07p^{1.14}$ cm/sec
37-48	a sharp drop in rate was observed
48-200	failed to burn
200-400	$u = -11.5 + 0.0635p$ cm/sec

Refs: 1) Beil, not found 2) A.E. Fogel'zang et al, FizGoreniyaVzryva 8, 257 (1972) & CA 78, 45833 (1973)

Tetramethylene-Diperoxide-Dicarbamide. See in Vol 5, D1337-R under "Dimethyleneperoxide-carbamide" and the following *addnl Ref*: 1) A. Weale & A. Renfrew, BritP 415779 (1934) & CA 29, 1251 (1935) [The inventors suggest

usage in priming compns along with such ingredients as MF, PbSt, Ba nitrate, K chlorate, Sb sulfide and Guanyl nitrosoaminoguanyltetrazene]

N,N,N',N'-Tetramethylethylenediamine Diperchlorate. $(\text{CH}_3)_2\text{NCH}_2\text{CH}_2\text{N}(\text{CH}_3)_2 \cdot 2\text{HClO}_4$; $\text{C}_6\text{H}_{18}\text{Cl}_2\text{N}_2\text{O}_8$; mw 317.13; OB to CO_2 -60.5%; cryst solid; mp 228-31°

Its impact sensy using the PicArns app with a 2-kg wt was 8" for at least one expln in ten tries. A stoichiometric soln in 100% nitric acid has been patented as a monopropnt

Refs: 1) Beil, not found 2) R.C. Doss, USP 3031838 (1962) & CA 57, 7508 (1962)

1,1,2,2-Tetramethylethylhydroperoxide-p-Nitrobenzoate. $(\text{O}_2\text{N})\text{CH}_6\text{H}_4[\text{CO.O.O.C}(\text{CH}_3)_2\text{CH}_2(\text{CH}_3)_2]$; mw 267.31; N 5.24%; OB to CO_2 -176.57%; colorl leaflets; mp 57-58°. Prepn is by treating the hydroperoxide with p-nitrobenzoylchloride in pyr at 0°. The ester explds when exposed to a flame

Refs: 1) Beil, not found 2) R. Criegee & H. Dietrich, Ann 565, 139 (1948) & CA 43, 6189 (1949)

N,N,N',N'-Tetramethyl-1,6-Hexanediamine Diperchlorate. $(\text{CH}_3)_2\text{N}(\text{CH}_2)_6\text{N}(\text{CH}_3)_2 \cdot 2\text{HClO}_4$; $\text{C}_{10}\text{H}_{26}\text{Cl}_2\text{N}_2\text{O}_8$; mw 372.24; OB to CO_2 -103.2%; cryst solid; mp 158-62°

Its impact sensy using the PicArns app with a 2-kg wt was 60" for at least one expln in ten tries. A stoichiometric soln in 100% nitric acid (flash pt < -70°; storage stab at 200°F, 27.5 hrs) has been patented as a monopropnt

Refs: 1) Beil, not found 2) R.C. Doss, USP 3031838 (1962) & CA 57, 7508 (1962)

Tetramethyllead (TML). $(\text{CH}_3)_4\text{Pb}$; mw 267.33; colorl, dense, strongly refractive liq with a pleasantly sweet odor; v toxic; f pt -27.5°; bp 110° at 10mm; d 1.995g/cc. Sl sol in benz, ethanol, petr eth; insol in w. Prepn is by means of the Grignard reaction of Pb chloride with an absol ethereal soln of methyl Mg chloride. The compd is stable and may be stored for years in

a brn, glass-stoppered bottle. Lower expln level in air is 1.8%. Flash pt is 100°F. TML detons *violently* above 90°. It has a toxic tolerance level in air of 0.15mg/cubic meter

Refs: 1) Beil 4, 639, (591), [1018] & {1938} 2) G. Brauer, Ed, "Handbook of Preparative Inorganic Chemistry", Vol 1, 2nd Edn, Academic Press, NY (1963), 763-65 3) Sax (1968), 870 4) L. Bretherick, "Handbook of Reactive Chemical Hazards", CRC, Cleveland (1975), 428 5) CondChemDict (1977), 850-51

N,N,N',N'-Tetramethylnepentanediamine Dipchlorate (N,N,N',N',2,2-Hexamethyl-1,3-Propanediamine Dipchlorate). $(\text{CH}_3)_2\text{NCH}_2\text{C}(\text{CH}_3)_2\text{CH}_2\text{N}(\text{CH}_3)_2 \cdot 2\text{HClO}_4$; $\text{C}_9\text{H}_{24}\text{Cl}_2\text{N}_2\text{O}_8$; mw 359.22; OB to CO_2 -98.0%; cryst solid; mp 185-86°

Its impact sensy using the PicArns app with a 2-kg wt was 26" for at least one expln in ten tries. A stoichiometric soln in 100% nitric acid (flash pt <-75°; storage stab at 200°F, 28 hrs) has been patented as a monopropnlnt

Refs: 1) Beil, not found 2) R.C. Doss, USP 3031838 (1962) & CA 57, 7508 (1962)

Tetramethylcyclohexanone Tetranitrate

[Sixonite, 2-Oxo-1,1,3,3-tetrakis-nitryloxy-methyl-cyclohexane, 1,1,3,3-Tetrakis-nitryloxy-methyl-cyclohexanone-(2), or 2,2,6,6-Tetrakis (nitryloxymethyl) cyclohexanone]. $\text{C}_6\text{H}_6\text{O}(\text{CH}_2\text{O}\cdot\text{NO}_2)_4$; mw 398.28; N 14.1%; OB to CO_2 -56.2%; mp 55-56°. Prepn is by nitration of 1,1,3,3-tetrakis-hydroxymethyl-cyclohexanone-(2) with mixed acid

The ketone has a Q_C^V of 3153cal/g; a sensy comparable to Tetryl; power by BalMort equal to 114% TNT

An analogous hexanol derivative is **Tetramethylcyclohexanol Pentanitrate** (Sixolite); $\text{C}_{10}\text{H}_{15}\text{N}_5\text{O}_{15}$; mw 445.3; N 15.7%; OB to CO_2 -44.9%; energy of formation -334kcal/kg; enthalpy of formation -357kcal/kg (Ref 3)

Refs: 1) Beil 8, {3974} 2) Blatt, OSRD 1085 (1942), 80 3) R. Meyer, "Explosives", Verlag Chemie, NY (1977), 259

Tetramethylcyclopentanol Pentanitrate. See under "Fivolite" in Vol 6, F40-R to F41-L
Addnl Ref: R. Meyer, "Explosives", Verlag Chemie, NY (1977), 259

Tetramethylcyclopentanone Tetranitrate. See under "Fivonite" in Vol 6, F41-L & R

Addnl Refs: 1) Beil 8, {3974} 2) H. Henkin & R. McGill, IEC 44, 1391-95 (1952) & CA 46, 8857 (1952) [Fivonite has an activation energy of 13.5kg-cal; an expln temp-time relationship of 0.300sec at 350°; 0.490sec at 320°; 0.760 sec at 300°, and 3.35secs at 232°; an impact sensy equal to 62% PA (or, comparable to TNT); power by BalMort equal to 122% TNT; and power by Trauzl Pb block test equal to 117% PA]

1,1,4,4-Tetramethylol-1,4-Dinitrobutane Tetranitrate. $(\text{O}_2\text{N}\cdot\text{O}\cdot\text{CH}_2)_2\text{C}(\text{NO}_2)\text{C}_2\text{H}_4\text{C}(\text{NO}_2)(\text{CH}_2\cdot\text{O}\cdot\text{NO}_2)_2$; mw 448.26; N 18.8%; OB to CO_2 -21.4%; mp 131.5-34° (corr). Prepn is by condensation of 1,4-dinitrobutane with formaldehyde followed by nitration with mixed acid. The compd has a sensy comparable to PETN, power by BalMort equal to 147% TNT, and a Pb block test value equal to 156% TNT

Refs: 1) Beil, not found 2) Blatt, OSRD 1085 (1942), 81 3) Anon, "Report on Study of Pure Explosive Compounds . . .", Part I, ADL, Cambridge (1947), 119

1,1,5,5-Tetramethylol-1,5-Dinitropentane Tetranitrate. $(\text{O}_2\text{N}\cdot\text{O}\cdot\text{CH}_2)_2\text{C}(\text{NO}_2)\text{C}_3\text{H}_6\text{C}(\text{NO}_2)(\text{CH}_2\cdot\text{O}\cdot\text{NO}_2)_2$; mw 462.25; N 18.02%; OB to CO_2 -31.2%; mp 84-85°. Prepn is by condensation of 1,5-dinitropentane with formaldehyde followed by nitration with mixed acid. Impact sensy is greater than TNT. The compd indicated a power of 137% TNT by BalMort and 145% TNT by Pb block test

Refs: 1) Beil, not found 2) Blatt, OSRD 1085 (1942), 81 3) Anon, "Report on Study of Pure Explosive Compounds . . .", Part I, ADL, Cambridge (1947), 119

N,N,N',N'-Tetramethyl-1,3-Propanediamine Dichlorate. $(\text{CH}_3)_2\text{NCH}_2\text{CH}_2\text{CH}_2\text{N}(\text{CH}_3)_2 \cdot 2\text{HClO}_4$; $\text{C}_7\text{H}_{20}\text{Cl}_2\text{N}_2\text{O}_8$; mw 331.16; OB to CO_2 -77.3%; cryst solid; mp 228-30°

Its impact sensy using the PicArns app with a 2-kg wt was found to be 18" for at least one expln in ten tries. A stoichiometric soln in 100% nitric acid (I_{sp} of 221.17secs at 20 atm; storage stab at 200°F, 33.7 hrs) has been patented as a monopropnt

Refs: 1) Beil, not found 2) R.C. Doss, USP 3031838 (1962) & CA 57, 7508 (1962)

1,1,4,4-Tetramethyltetramethylene-dihydroperoxide. See under "2,5-Bis(hydroperoxy-2,5-dimethyl)-hexane" in Vol 2, B144-R

Tetramino Cupric Nitrate [or Tetraammine copper (II) nitrate]. $[\text{Cu}(\text{NH}_3)_4](\text{NO}_3)_2$; mw 255.73; N 32.87%; purple monocl cryst. Sol in ammonia and w. Prepn is by addn of aq amm hydroxide to an aq soln of cupric nitrate with stirring at 5°. The ppt formed is filtered off, ethanol-eth washed and air-dried. The salt has a booster sensy of 0.24g MF, 0.19g Tetryl; an expln temp of 331°; an impact sensy of 19cm (BM app, LA 16cm); a sand test value of 17.2g (200g sand bomb, LA=18g); and a sensy to flame, on ign giving a green flame

Phillips (Ref 2) conducted an investigation of the impact sensy increase of Amatol mixts contg this compd as an accidental prod of the combined action of NH_4 ion, air and moisture on metallic Cu at high temp, or by the action of basic nitrates of Cu on metallic Cu at normal temps. He reports that in a 50/50 mixt of TNT/Tetramino-cupric nitrate, the impact sensy is 14" as compared to 19" found for 50/50 Amatol. Phillips accordingly recommended that no Cu or Cu alloys be used in any eqpt which may come in contact with Amatol during its manuf

King reports addnl expl parameters in Ref 3, resulting from work designed to explore the sensy of this Cu salt to mechanical stimuli, as well as to determine its TNT equivalent value. He found that in a friction pendulum test he obtd 14 ignitions out of 15 tries at 21cm; in impact sensy testing, first using a type 12 tool with a 2.5-kg wt, no detons were observed at 30cm

(10 tries); and 6 detons out of 10 tries were observed at 60cm (RDX=38cm). Next, using a Rotter tool and a 2.5-kg wt, no detons were observed at any ht; and finally, using a BM app no detons were observed at 10" or greater. Also reported is the power by BalMort as 81% that of TNT

For addnl information on ammine complexes and Cu ammine complexes see in Vol 1, A275-L to A286-R under "Ammine or Ammoniate Coordination"

Refs: 1) Beil, not found 1a) Gmelin, Syst Nr 60, Teil B (1960), 180 ff 2) A.J. Phillips, "Study Properties of Tetramino Cupric Nitrate", PATR 1302 (1943) 3) A.W. King, "Sensitivity of Tetramino Cupric Nitrate Complex", File 765-AF, DuPont & Canada Ltd, Ontario (Jan 1974) 4) L. Bretherick, "Handbook of Reactive Chemical Hazards", CRC, Cleveland (1975), 720

2,4,6,8-Tetranitramino-1,3,5,7,9-Pentamethylene-1,9-Dinitrate. $(\text{O}_2\text{NO})\text{CH}_2\text{N}(\text{NO}_2)\text{CH}_2\text{N}(\text{NO}_2)\text{CH}_2\text{N}(\text{NO}_2)\text{CH}_2(\text{ONO}_2)$; $\text{C}_5\text{H}_{10}\text{N}_{10}\text{O}_{14}$; mw 434.25; N 51.58%; OB to CO_2 -3.68%; cryst; mp 211°. Was obtained during WWII as a by-product of the manuf of RDX using either the E-Salz or K-Salz processes (see Vol 3, C613-R to C614-R). The power of this compd by Trauzl Test was claimed to be greater than that of RDX

Ref: B.T. Fedoroff et al, "Dictionary of Explosives, Ammunition and Weapons (Geman Section)", PATR 2510 (1958), 197-L & R

2,3,4,6-Tetranitroacetanilide. See in Vol 1, A24-L under "Acetanilide" and under "Acetyl-tetranitroaniline" on A87-R

Tetranitroaniline. See in Vol 1, A411-L to A414-L under "2,3,4,6-Tetranitroaniline (TeNA) . . ." Addnl Ref: R. Meyer, "Explosives", Verlag Chemie, NY (1977), 259-60

Tetranitrobenzene. See in Vol 2, B50-L & R

Tetranitrobenzophenone. See in Vol 2, B78-L

Tetranitrobiphenyl Isomers. See in Vol 2, B124-L & R and the following *Addnl Ref*: J.C. Hoffsommer & J.F. McCullough, "Thermal Stabilities of Tetranitrobiphenyl Isomers at Elevated Temperatures", **NOLTR 68-159** (1968), 3
[Table 1 summarizes the thermal stabilities, melting pts and impact sensys of six isomeric tetranitrobiphenyls:

OB to CO₂ -85.2%; energy of formation +28.3 kcal/kg or +118.5kJ/kg; enthalpy of formation +13.0kcal/kg or +54.4kJ/kg; and heat of expln 890kcal/kg or 3726kJ/kg

1,3,6,8 TNC is insol in w, eth, alc and CCl₄, and is readily sol in benz. It is not hygr]

"**Tetranitrocellulose**". The name given by Daniel (Ref 2) to a compd obtained by first nitrating collodion cotton (called variously

Table 1
Thermal Stabilities, Melting Points, and Impact Sensitivities of Six Isomeric Tetranitrobiphenyls

Tetranitrobiphenyl Isomer	Melting Point, °C	Impact Sensitivity (a), cm	(% Decomposition)/(Hour) (b)	
			260°C	280°C
3,3',5,5'-	231-232	208	0.10	-
4',2,4,6-	200-201	252	0.20	0.60
3',2,4,6-	182-183	308	0.20	1.0
2,2',6,6'-	219-220	85	1.1	4.4
2,2',4,4'-	165-166	198	1.6	9.2
2',2,4,6-	175-177	180	2.1	-

(a) 50% height of a 2.5-kg weight on sandpaper with type 12 tools

(b) Spectrophotometric analysis of isomer-EDA complex in DMSO solution, after separation and extraction of isomer from silica gel on TLC plates]

Tetranitrocarbazole (TNC; Tétranitrocarbazol). See in Vol 2, C48-L to C50-R, plus the following *Addnl Refs*: 1) H. Ellern, "Military and Civilian Pyrotechnics", Chemical Publishing Co, NY (1968) [p 173-Ger during WWII attempted to replace hygroscopic BlkPdr in illuminant igniter applications with TNC/K nitrate/Al powd formulations; p 193-TNC was proposed for use in fire transfer disc formulations; and p 203-In the UK, work on slow-burning delay trains employ high gassing mixts using fuels such as TNC with Ba nitrate] 2) R. Meyer, "Explosives", Verlag Chemie, NY (1977), 260

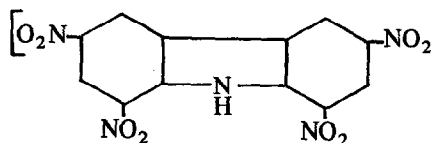

soluble NC, pyroxyline, dinitrocellulose or "octanitrocellulose") with a 1:1 mixt of sulfuric-nitric acids (d 1.5g/cc) to the guncotton stage (or "trinitrocellulose"). After separation from the spent acid, the product is treated with a mixed acid comprised of concd sulfuric and anhydr phosphoric acids. Subsequent washing and drying of the compd resulting from this treatment produces a brittle solid which is easily detonated on impact. The final processing step consists of digesting the brittle solid with a concd aq soln of perchloric acid. The "Tetranitrocellulose" produced by this step is even more brittle and impact sensitive than that of the prior synthesis stage, behaving more like a primer than a propnt

See also under "Cellulose Nitrates or Nitrocelluloses" in Vol 2, C100-R

Refs: 1) R. Warren, *ChemN* **85**, 239 (1901)
2) Daniel (1902), 765

Tetranitrodibenzo-1,3a,4,6a-Tetrazapentalene.
See in Vol 5, D1184-R to D1185-R, and in this
Vol under "TACOT"

Tetranitrodiglycerin (TeNDG). See under "Di-
glycerol and Derivatives" in Vol 5, D1261-L & R

1,5,1',5'-Tetranitro-Diimidazolyl-(2,2') and its
Salts. $C_6H_2N_8O_8$, mw 314.16; N 35.68%; OB
to CO_2 -25.46%; yel prisms (+2H₂O, from w);
mp 276° (decompn). V sol in hot w; sol in
ethanol, eth and acetic acid. Prepn is by ni-
trating diimidazolyl-(2,2') with a mixt of fuming
nitric and concd sulfuric acids at 165°. The
compd is v expl. It forms the following salts
which expld upon heating: The **Dipotassium
Salt**, $K_2C_6N_8O_8 \cdot 2H_2O$, red-brn ndles; **Disilver
Salt**, $Ag_2C_6N_8O_8 \cdot 2H_2O$, red-brn ndles; and **Di-
sodium Salt**, $Na_2C_6N_8O_8 \cdot 2H_2O$, orn-red, v sol
in w

Ref: Beil **26**, [215]

Tetranitro Erythritol. See in Vol 5, E124-R to
E125-L under "Erythritol Tetranitrate . . ."

Tetranitrogen Tetrasulfide. See "Sulfur Nitride"
in Vol 8, N102-L to N103-L

Tetranitroglycoluril. See in Vol 6, G117-R to
G118-L. *Addnl Ref:* R. Meyer, "Explosives",
Verlag Chemie, NY (1977), 80-81 [d 2.01g/cc;
deton vel 9150m/s; deflagration pt 237°; impact
sensy 0.15-0.2kg/m; is also called *Sorguyl*; it
decomps when mixed with molten TNT]

Tetranitromethane (TeNMe). See in Vol 8, M83-L
to M85-R

Tetranitromethylaniline. One of the names for
Tetryl

Tetranitronaphthalene (TeNM). See in Vol 8,
N14-R to N16-R

**1,3,5,7-Tetranitro, Octahydro-1,3,5,7-Tetrazo-
cine (HMX).** See in Vol 3, C605-R to C610-R,
under "Cyclotetramethylenetetranitramine . . .
or HMX . . .", and in Vol 8, P415-R & P416
(Table 19), under "C. High Energy Solid Propel-
lants". Also called Tetramethylenetetranitra-
mine; 1,3,5,7-Tetraza-1,3,5,7-tetranitrocyclo-
octane; or Octohydro-1,3,5,7-tetranitro-s-tetrazo-
cine. CA Registry No [2691-41-0]. More
current information on HMX is to be found in
the following *Addnl Refs:*

I. Explosives

A. Crystallographic Studies

1) H.H. Cady, A.C. Larson & D.T. Cro-
mer, "The Crystal Structure of α -HMX and a
Refinement of the Structure of β -HMX", *Acta-
Cryst* **16** (7), 617-23 (1963) & *CA* **59**, 12260
(1963) [The crystal structure of α -HMX, as detd
by single cryst X-ray, is reported; the unit cell
is orthorhombic, space group Fdd2 with a=
15.14, b=23.89 and c=5.913Å; there are eight
molecules in the unit cell. The molecules have a
basketlike shape with two-fold symmetry. Bond
lengths and angles all have normal values, how-
ever there are two rather short intermolecular
C-O distances of 3.04 (C₂-O₄) and 3.20Å
(C₁-O₃)

Data reported for β -HMX shows a=6.54, b=
11.05 and c=8.70Å; while $\beta=124.3^\circ$. Fig 1 is a
dwg of β -HMX showing intermolecular distances
and angles. The distances in parentheses are ref
data obt'd by the authors from P.R. Eiland & R.
Pepinsky, *ZKrist* **106**, 273 (1955) & *CA* **49**,
14416 (1955)]

2) C.S. Choi & H.P. Boutin, "A Study of the
Crystal Structure of β -Cyclotetramethylenetetra-
nitramine by Neutron Diffraction", *ActaCryst*
B26, 1235 (1970) & *CA* **73**, 134889 (1970).
[The heavy-atom parameters obt'd agree with
those from X-ray determinations except for
slight position shifts of a few atoms. The study also
concludes that all hydrogen atoms are located close
to nearby oxygen atoms, a few of which form intra-
molecular or intermolecular hydrogen bonds of the
type C-H . . . O. An R value of 0.059 was found]

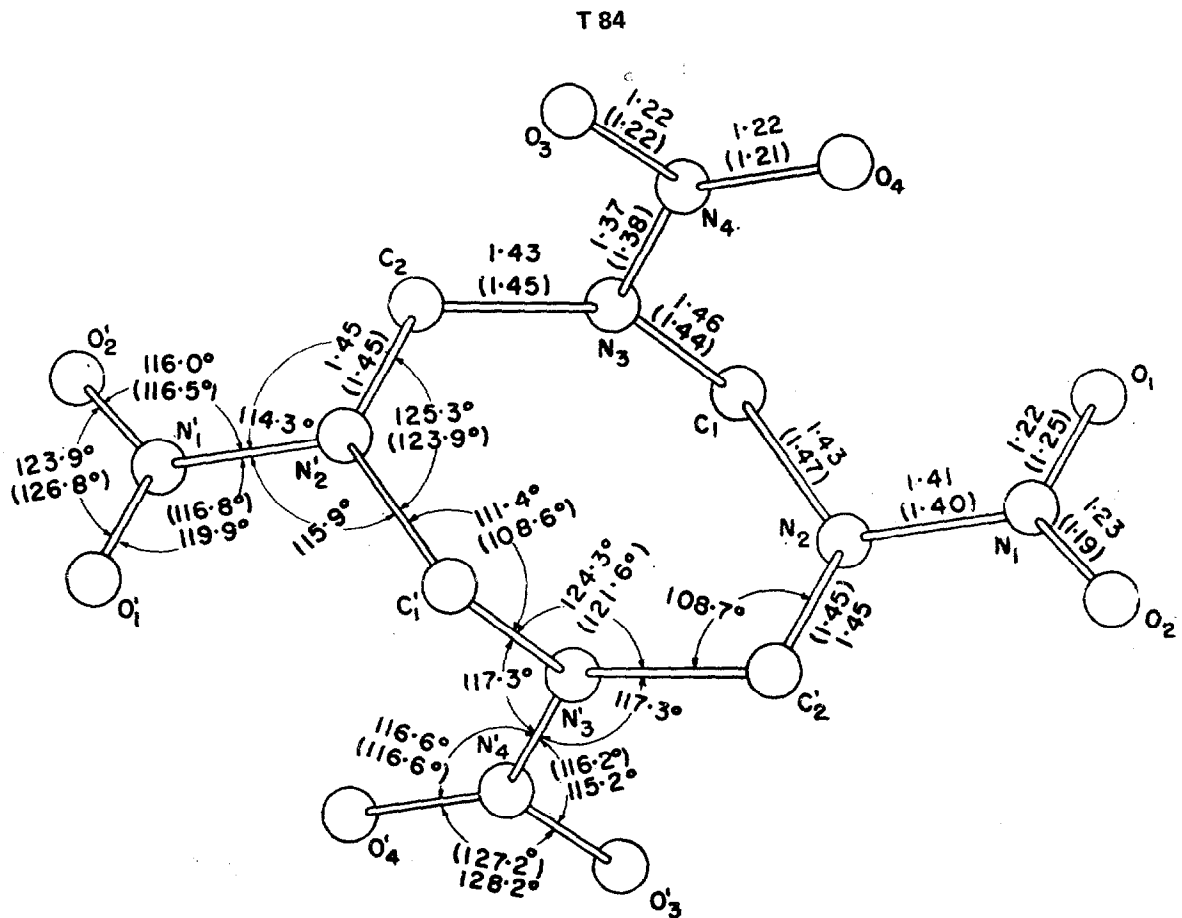

Fig 1 Drawing of β -HMX molecule showing interatomic distances and angles.
The distances given by a previous ref (in text) are shown in parentheses (Ref 1)

3) R.E. Cobbleddick & R.W. Snrall, "The Crystal Structure of the δ -Form of 1,3,5,7-Tetranitro-1,3,5,7-Tetraaza Cyclooctane (δ -HMX)", Acta-Cryst **B30**, 1918 (1974) & CA, not found. [The authors used direct methods of computerized data reduction from X-ray counter intensities to determine the cryst structure of δ -HMX. They found that the crystals are hexagonal, space group P6, (P6₅), with $a=7.711$ (2), $c=32.553$ (6)Å, and $Z=6$; the final R is 0.115 (from 1126 observed reflections); the four C atoms of the eight-membered ring of δ -HMX are planar; the molecule has approx two-fold symmetry about an axis perpendicular to the plane of the eight-membered ring and thru its center; the shape of the molecule is similar to that of the α -polymorph which has crystallographic two-fold symmetry. See Fig 2 for stereoscopic views of both α - and δ -HMX

B. Detonation Studies

4) H.S. Leopold, "Initiation of Explosives by Exploding Wires—VIII. Survey to Determine Explosives Capable of Initiation at Moderate Voltage Levels", NOLTR 65-127 (1965) [The initiation data was gathered using a 2-mil diam Au wire expld by a 1-microfarad capacitor charged to either 2000 or 4000 volts. HMX of <44 micron particle size and d of 1.1g/cc was detonated high order at the 4000 volt level, exhibiting a deton vel of 1160m/sec] 5) S. Bulusu et al, "Mechanism of Thermal Decomposition of HMX...", PA(FRL)R (1968) (AD 837173) [The authors conclude that the thermal decompn of HMX involves the breakage of C-N bonds, and the major products of decompn are formaldehyde and N₂O] 6) J.M. Blain et al, "Evaluation of Detonating Cord by Framing Camera Technique", ProcSixthElectrexpDev, Franklin

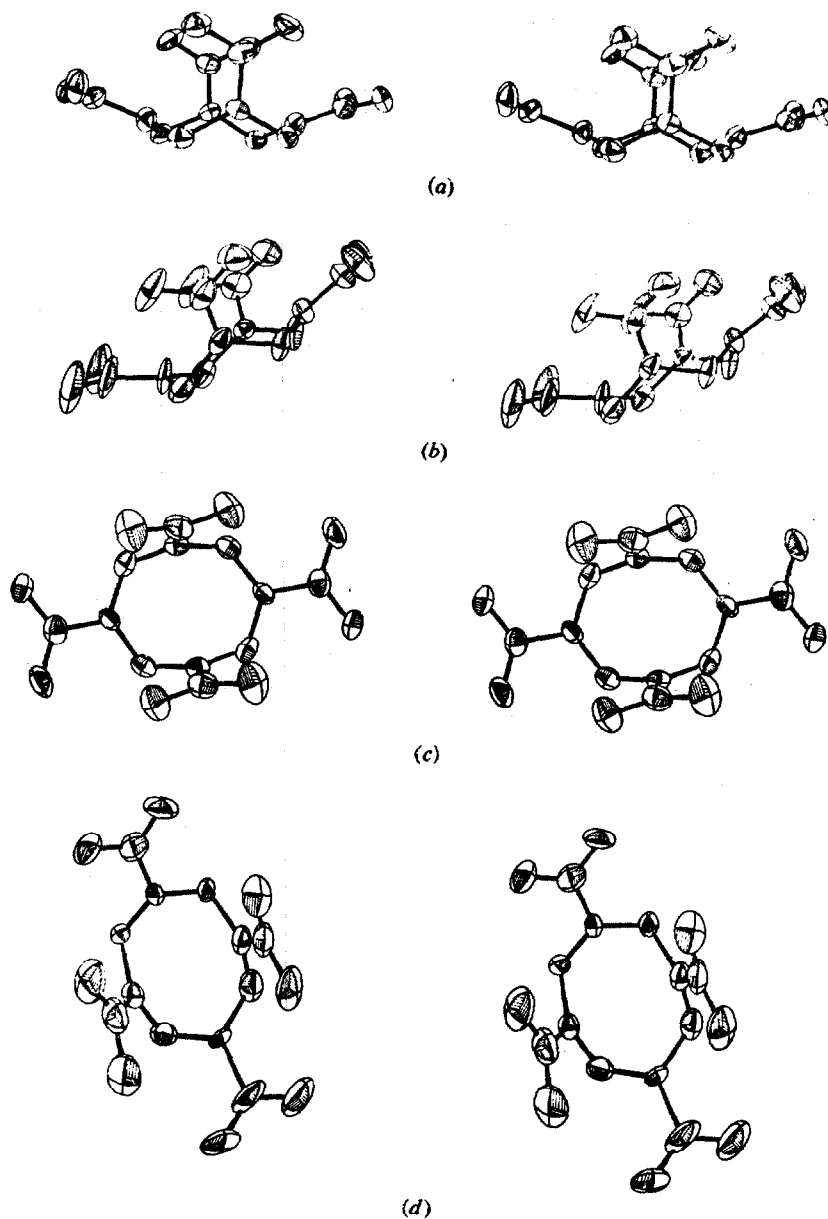

Fig 2 Stereoscopic views of α -HMX and δ -HMX showing thermal ellipsoids with 50% probability. (a) α -HMX viewed from the side. (b) δ -HMX viewed from the side. (c) α -HMX viewed from above. (d) δ -HMX viewed from above (Ref 3)

Inst, San Francisco (1969), section 4-11.1 to 4-11.19. [The study revealed that 11 grains/ft HMX core primer cord with Pb-polyethylene sheathing deton at 7850m/sec; the fragment vel of the sheath is 650m/sec] 7) M.J. Barbarisi & E.G. Kessler, "Initiation of Secondary Explosives by Means of Laser Radiation", PATR 3861 (1969). [Reliable direct deton of HMX is obtd

by means of the collimated photon emission from a Q-switched ruby laser (6943Å) when the expl is under a compression of 13,500psi. Although no initiation energy data is given for HMX, the initiation energy required for expls such as PETN is reported as 0.0252 to 0.0399 Joules/sq mm] 8) J.E. Sinclair, "The Effect of Pressure on the Autoignition of HMX",

Explosivst 17 (11/12), 259–62 (1969) & CA 73, 5583 (1970). [The author concludes that the deton of HMX is caused by autoignition, and that the time to deton is directly proportional to the ambient press and loosely obeys the burning rate—press relationship laws of proplnts. Deton rate= B_2 press+ A_2 , where A_2 is the slope of the press-time curve and B_2 is the intercept]

9) W. Kegler, "Comparative Study of the Explosive Properties of RDX–TNT and HMX–TNT", *ChimIndGenieChim* 103 (12), 1549–55 (1970) & CA 73, 122066 (1970) [It was found that HMX was more effective in increasing the d of a charge than RDX, and that HMX detonated more rapidly. For example, at 40–30% TNT content, the d increases are reported as 2.8mg/cc and 1.75mg/cc per 1% of HMX and RDX, respectively. Also, the deton vels are 8254m/sec and 8070m/sec for charges of infinite diam contg 65% HMX and 65% RDX, respectively]

9a) E.L. Lee et al, "Thermal Decomposition of High Explosives at Static Pressures 10–50 Kilo-bars", UCRL-72172, 5thSympDeton, Pasadena (1970) [The measurement of the time to expln of HMX under static press up to 50kbar at various temps is shown on an Arrhenius plot in Fig 3. The authors conclude from these measurements that the gaseous intermediate species of HMX deton are suppressed by high press, thus reducing the rate of decompn]

10) R.N. Rogers, "Thermochemistry of Explosives", *ThermochemActa* 11 (2), 131–39 (1975) & CA 82, 142281 (1975) [Using the equation

$$\frac{E}{T_m} = R \ln \left[\frac{a^2 \rho QZE}{T_m^2 \lambda \delta R} \right], \text{ where}$$

$E=52.7\text{kcal/mole}$ =the activation energy from the Arrhenius expression; T_m =the critical temp or the lowest constant surface temp of an expln above which an expln is produced; R =the gas constant ($1.9872\text{cal/mole}^\circ\text{K}$); $a=0.033\text{cm}$ =the radius of a sphere or cylinder or half-thickness of a slab; $\rho=1.81\text{g/cc}$; d ; $Q=500\text{cal/g}$ =heat of reaction during the self-heating process; $Z=5 \times 10^{19}/\text{sec}$ =the pre-exponential; $\lambda=7.0 \times 10^4/\text{cm-sec}^\circ\text{C}$ =the thermal conductivity; and δ =the shape factor (0.88 for infinite slabs, 2.00 for infinite cylinders and 3.32 for spheres). The author calcd T_m for HMX as 253° as compared to exptl values of 253 – 255° 11) A.Ya. Apin & G.V. Dimza, "Detonation of Filled Composition Explosives", *VzryvnoeDelo* 74/31, 13–17 (1974) & CA 82, 113760 (1975) [The authors report on a study where the deton rate was detd as a function of compn (HMX/paraffin), particle size (5 to 40mm), and the diam of the charge. It was found that the deton rate increases smoothly, then at a critical diam expands at a constant max speed before gradually decreasing. Measured deton rates ranged from approx 5000 to 8500m/sec] 12) F.E. Walker, "Effects of Free Radicals in the Shock Initiation of Explosives", UCID-16858-76-1 (1976) [In an initial set of expts designed to control the rate of the HMX initiation process, the author added 5% of tetramethylammonium triborohydride (QMB₃). This

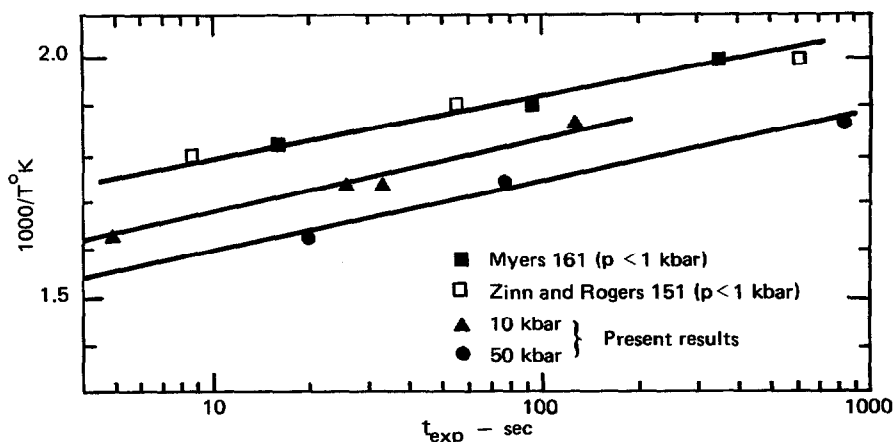

Fig 3 Time to Explosion for HMX (Ref 9a)

compd is considered a radical donor which should enhance the deton rate of HMX and increase the impulse generated (as measured by plate dent). However, this was not the case. The impulse is lessened in the QMB₃ added HMX compn, yielding a smaller plate dent depth]

13) G. Petino, Jr & D. Westover, "Detonation Propagation Tests on Aqueous Slurries of RDX, HMX, M-1, and Nitrocellulose", **ARLCD-CR-77002**, Hazards Research Corp, Denville, Contract No DAAA21-73-C-0772 (1977) [The purpose of the series of tests described in this report was to determine if a deliberately initiated deton would propagate in any of the aq HMX slurries of various concns tested when confined in horizontal, 2" diam, schedule 40, stainless steel pipes up to 40" in length. The authors conclude the following from their data: 1) ". . . Gelled HMX slurries propagate high-order detonations at 30% HMX concentrations, partially propagate at 25%, and do not propagate at 20% concentrations . . ." 2) ". . . Settled HMX slurries propagated high-order detonations at and above 10% HMX concentrations. A detonation occurred at the 5% level in 1 of 3 trials . . ."; and 3) ". . . HMX in an aqueous, settled slurry is the most sensitive material tested in this program . . ."]

14) B.I. Shekhter et al, "Effect of Elevated Temperatures and Hydrostatic Pressure on the Detonation Characteristics and Sensitivity of Explosives", *FizGoreniyaVzryva* **1978**, 14 (5), 163-67 (Russ) & *CA* **90**, 57482 (1979) [Expts were performed with elongated cartridges of HMX inserted in 0.5mm wall thickness Al castings which were exposed to a temp range of 150-230° and pressures of 80-150MPa. At ≤ 170°, the deton vel increased by 3-5%. Above 170°, the deton vel decreased because of the thermal decompn of HMX. The saturation of the HMX cartridges with liq at elevated press and temps increased the sensy of HMX]

C. Deflagration to Detonation Studies

15) G. Dauge et al, "Pressure Dependence of Solid Explosives Initiation", *ProcIntSympCombustn* **15**, 21-27 (1975) & *CA* **85**, 162889 (1976) [A study involving a thermal energy source consisting of either a laser or a hot wire applied in a controlled press environment to an HMX PBX indicates a deflagration press threshold of 0.4kbar. The authors conclude that below this press threshold no stable stationary ignition state is possible

because of the rapid expansion of gaseous reaction products of low heat conductivity, and the heat flux over the surface is insufficient to sustain expl fusion] 16) D. Price & R.R. Bernecker, "DDT Behavior of Waxed Mixtures of RDX, HMX and Tetryl", **NSWC/WOL TR 77-96** (1977), pp 14 & 23 [Several interesting effects upon deton of HMX and HMX/wax mixts were noted; viz, class A RDX and HMX were found to be indistinguishable in their DDT behavior; the porosity of HMX/wax is affected at the 70% theoretical max d point to the extent of a decrease in burning rate and reactivity with increasing wax content] 17) M.W. Beckstead et al, "Convective Combustion Modeling Applied to Deflagration-to-Detonation Transition (DDT)

Table 1
Physical Properties and Configuration
of Baseline System (Ref 17)

Propellant Properties	
Burning rate proportionality constant (in/sec/psi ⁿ)	9 x 10 ⁻⁴
Burning rate exponent	0.9
Propellant density (gm/cc)	1.91
Grain diameter (microns)	200
Initial grain temp (°K)	295
Thermal diffusivity of a grain (cm ² /sec)	1.1 x 10 ⁻³
Chemical energy released (cal/gm)	1356
Initial porosity	0.30
Molecular weight of propellant gas	24.09
Polytropic gas constant	1.333
Numerical Configuration	
Number of stations at which data is taken	41
Artificial viscosity coefficient	0.4
Grid mesh (inches)	0.05 (1.27mm)
Total calculational length (inches)	2.0 (50.8mm)
Start Conditions	
Length of preignition constant (inches)	0.2 (5.1mm)
Length of preignition ramp (inches)	0.5 (12.7mm)
Preignition gas temperature amplitude (°K)	1865
Preignition pressure amplitude (psi)	1440 (~0.1kb)

Table 2
Parameter Values for Variation of DDT Characteristics (Ref 17)

Parameter varied	Parameter changes	Grid mesh (inches)	Ignition section changes		Runup length (inches)	Runup time (μ sec)
			Constant	Ramp		
Baseline	—	0.05	None	None	0.6	41.7
Particle diameter	200 μ \rightarrow 20 μ	0.01	None	None	0.11	4.4
Particle diameter	200 μ \rightarrow 100 μ	BL	None	None	0.35	20.4
Particle diameter	200 μ \rightarrow 400 μ	BL	2 x BL	2 x BL	0.9	90.0
Particle diameter	200 μ \rightarrow 1200 μ	0.10	2 x BL	2 x BL	1.9	270.0
Porosity	0.3 \rightarrow 0.2	BL	None	None	0.35	19.4
Porosity	0.3 \rightarrow 0.5	BL	None	None	1.27	105.0
Diameter and porosity	D = 67 μ ϕ = 0.45	BL	None	None	1.3	34.8
Diameter and porosity	D = 67 μ ϕ = 0.35	BL	None	None	0.4	21.1
Diameter and porosity	D = 67 μ ϕ = 0.2	0.025	BL/2	BL/2	0.25	11.1
Diameter and porosity	D = 34 μ ϕ = 0.4	BL	None	None	0.3	13.5
Burn rate coefficient	1/2 x BL	BL	2 x BL	2 x BL	0.95	75.5
Burn rate coefficient	2 x BL	BL	None	None	0.3	16.9
Chemical energy	BL/1.3	BL	None	None	0.65	55.6
Chemical energy	1.3 x BL	BL	None	None	0.4	30.2
Particle diameter & drag	200 μ \rightarrow 1200 μ drag = 1/10 x BL	0.10	None	None	2.3	264.2
Drag	1/10 x BL	BL	None	None	0.7	41.7
Heat transfer	2 x BL	BL	None	None	0.65	49.5
Ignition (bulk) temp	311 $^{\circ}$ K \rightarrow 322 $^{\circ}$ K	BL	None	None	0.6	45.3
Artificial viscosity coefficient	BL/2	BL	None	None	0.6	36.3
Artificial viscosity coefficient	BL/4	BL	None	None	0.6	36.3

Footnote to Table:

BL = baseline condition

of HMX", *Combustn&Flame* **30** (3), 231–41 (1977) & *CA* **88**, 76094 (1978) [The authors use a modified Kries/Van Tassel convective combustion computer code in the analysis of HMX DDT. The code provides a description of the processes and variables involved in an accelerating convective combustion wave, and carries the

results sufficiently far into deton to obtain good agreement with existing exptl data (see Figs 4 & 5). To examine the effect of changing sensitive parameters such as particle diameter or porosity, a base set of information called "Runup length" and "Runup time" are used. These effects refer to the space-time point of initiation of a model

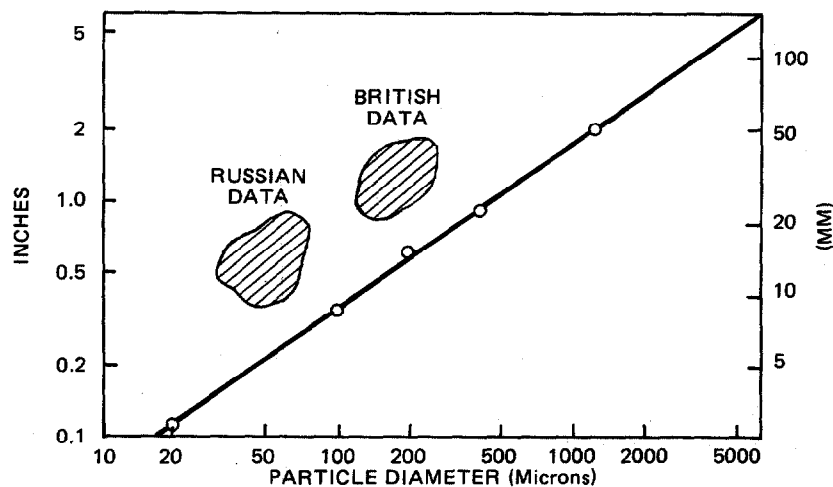

Fig 4 Variation of runup distance with particle diameter for baseline conditions compared to experimental data (Ref 17)

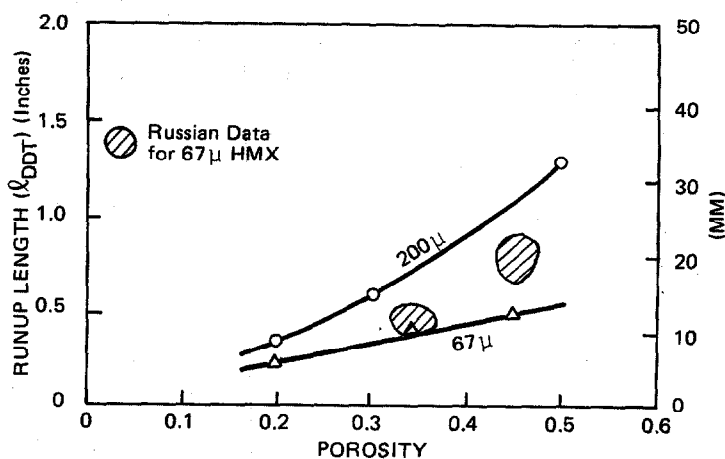

Fig 5 Variation of runup length with porosity (Ref 17)

baseline (HMX) system shown in Table 1. The computed effect of varying the sensitive parameters is shown in Table 2. Figs 4 & 5 compare actual data with calcd information.

The authors conclude that "... The runup length is related to sensitive parameters by power laws or other simple functional forms. The most significant appears to be the dependence of runup length on the explosive particle diameter ($l_{DDT} \sim D_p^{2/3}$)..."^a

^a— l_{DDT} is the Runup length for deton and D_p is the particle diameter

D. Energetic Properties

18) J. Haberman & T.C. Castorina, "The Surface Chemistry of HMX", PATR 3089 (1963) [A study was made of the solution-adsorption properties of HMX using a ¹⁴C labeled quarternary ammonium salt, stearyl trimethyl ammonium bromide (STAB). The solvent system used consisted of 10% ethanol and 90% w. The solution-adsorption system isotherms for 10-micron HMX were measured. The authors conclude that an H-type Langmuir adsorption isotherm is obtd, the adsorption of STAB on HMX is reversible and therefore physi-

cal in nature, the mechanism of adsorption is ammonium cation-dipole (HMX surface), and the ΔH_i is 15 Joules/g] 19) Y.P. Carignan & D.R. Satriana, "Differential Thermal Analysis of Nitramines, Amine Salts, and Guanidine Derivatives", JOC 32, 285-89 (1967) & CA 70, 10960X (1967) [The authors point out that the thermogram of HMX shows a violent decomp exotherm at 279°, just after the mp (276-78°). Also, in the thermogram of β -HMX, an endotherm was observed at 185°. They conclude that this endotherm indicates a crystal phase transition pt from the β form to the metastable δ form] 20) J.D. Wilcox, "Differential Scanning Calorimetry Methods in the Determination of Thermal Properties of Explosives", Master's Thesis, GAW/ME/67B-3, Air Univ, USAF, WPAFB, Ohio (1967) [Experimentally derived differential scanning calorimetry information from a variety of sources, as well as the author's own expts, is reported on the specific heat (0.26 to 0.32 cal/g·°K) of HMX over a temp range of from 312 to 422°K, and an activation energy reported variously as 228, 844 or 2100 kcal/mole. Probable sources of error in the data are included in the discussion sections of the report] 21) J.M. Rosen & C. Dickinson, "Vapor Pressures and Heats of Sublimation of Some High Melting Organic Explosives", NOLTR 69-67 (1969) [The data collected by the Langmuir method is used to compute the vapor pressures for β -HMX as shown in Table 3. The method uses the observed wt loss of a sample heated in a vac in the following expression: $P(\text{torr}) = 17.14 \times G \times (T/M)^{1/2}$, where
 G = wt loss in g/sq cm/sec
 T = absolute temp
 M = the molecular wt

Table 3
Vapor Pressure of β -HMX (Ref 21)

Temp $\frac{1000}{T}, ^\circ\text{K}$	Vapor Press, Torr
2.69	33×10^{-9}
2.615	18×10^{-8}
2.575	4×10^{-8}
2.49	3×10^{-7}

The heat of sublimation (ΔH_s) is detd as 41.9 kcal/mole] 22) J.E. Sinclair & W. Hondee,

"The Thermal Decomposition of β -HMX", Proc 7th Symp Expl&Pyrots, FIRL, Phila (1971) [DTA analysis of β -HMX in air at 1 atm using a heating rate of 2°/min revealed the endothermic process of the irreversible cryst phase change from β to δ at 192°, and the violent decompn of δ -HMX at 276°. Integration of the dx/dt or dT/dt curves for the activation energy expo- nent yields the data shown in Table 4

Table 4
 β -HMX Activation Energies (Ref 22)

Temp, °K	Activation Energy, kcal/mole
473-506	44.20
506-514	63.23
above 514	52.65]

23) R.N. Rogers & G.W. Daub, "Scanning Calorimetric Determination of Vapor-Phase Kinetics Data", AnalChem 45 (3), 596-600 (1973) & CA 78, 115708 (1973) [The kinetics of vap phase decompn of HMX at 550°K as detd by scanning calorimetry in constant vol cells having holes for vap exit, were found to be first-order with a value for the activation energy of 52.9 kcal/mole and a pre-exponential factor of $1.51 \times 10^{20} \text{sec}^{-1}$] 24) L.A. Shipitsin & P.B. Lerman, "Thermal Stability and Effectiveness of Cumulative Charges", PribiGeofiz, No 70, 217-22 (1973) (Russ) & CA 81, 15260 (1974) [The development of an analytical expression which correlates the critical temp of expl self-ignition, geometry, kinetic characteristics of thermal decompn, and thermophysical properties, is reported and applied to the effectiveness of HMX in charges of from 4-20mm in diam. This effectiveness is expressed as the depth of deformation in a steel slab caused by the expln. For the same HMX charge geometry, it is directly proportional to the expln temp and the square of the deton vel] 25) J. Harris, "Autoignition Temperatures of Military High Explosives by Differential Thermal Analysis", ThermochemActa 14 (12), 183-99 (1976) & CA 84, 107975 (1976) [The author obtd an autoign temp of 234° by calculating the peak DTA temp at a heating rate of 0.1°/min from his data, and extrapolating to the ign temp] 26) H.J. Scullion, "Quantitative Effect of Gritty Contaminants on the Sensitiveness of High Explosives to Initiation by Impact. II. Nonparametric Variant of Bruceton Procedure", JApplBiotech-

vol 25 (7), 503-08 (1975) & CA 84, 92350 (1976) [The normal Gaussian distribution of coarse HMX impact sensy is used to estimate the increased sensy of coarse HMX contg various amounts of fine (<63 microns) airborne grit by a statistical modeled expt. The exptl results were then used in a Bernoullian confidence level eqtn to determine the sample size required to accurately estimate the sensy of any grit contg HMX sample with a "K" % level of confidence. A sample of the type of "K" table derived is shown for HMX in Table 5]

Table 5
The Confidence Level (K) that Coarse HMX is Sensitized by 50 Parts/10⁶ of Fine (< 63 micron) Air-Borne Grit (Ref 26)

Sample Size, N	K (%)
10	98.92
20	99.50
30	99.73
40	99.88
50	99.999

27) R. Meyer, "Explosives", Verlag Chemie, NY (1977), pp 108, 117, 152, 201 & 282 [The four modifications of HMX are briefly discussed primarily under "Octogen". Transition enthalpies and temps (p 202) are of particular interest:

α to δ	- 5.98kcal/kg at 193-201°
β to δ	- 7.90kcal/kg at 167-183°
γ to δ	- 2.26kcal/kg at 167-182°
β to γ	- 5.64kcal/kg at 154°
α to γ	- 3.71kcal/kg
α to β	- 1.92kcal/kg at 116°

Also, the friction sensy which is stated as "12 kp pistil load"] 28) M.Ya. Vasil'ev, "Dependence of the Critical Excitation Energy of Explosion by Impact on the Density of Explosives", Deposited Doc, VINITI, 1247-76 (1975) & CA 88, 76093 (1978) [The critical impact energy and critical impact vel found for HMX as a function of d are shown below:

Density, g/cc	Critical Impact Energy, erg/g	Critical Impact Vel, m/sec
1.32	0.17 x 10 ⁹	191.2
1.81	0.40 x 10 ⁹	314.8]

29) R.A. Beyer, "Molecular Beam Sampling Mass Spectrometry of High Heating Rate Pyrolysis. Description of Data Acquisition System and Pyrolysis of HMX in a Polyurethane Binder",

USNTIS AD Rept, AD-A054328 (1978) & CA 89, 165651 (1978) [Relative amts of the major decompn products observed after low press pyrolysis are reported as N₂O (100), NO₂ (54), HCN (42), HCHO (39) and NO (27 parts). The author concludes that the large amt of NO₂ is compatible with the breaking of the N-N bond as the first step of thermal decompn of HMX] 30) R.H. Dinigar, "Ignition and Deflagration of Potassium Picrate (KP) and KP/Explosive Mixtures: Low-Voltage, Nonprimary Detonators", LA-UR-78-1298 (1978) & CA 90, 89613 (1979) [KP can be ignited by a 0.05mm diam Nichrome wire at 1-amp/1-watt level. It was found that mechanical mixts of KP/HMX (10/90 mass %) exhibit hot wire ign properties similar to those of pure KP. It was concluded that since this mixt generated higher press than pure KP, it could be used as a donor charge for accelerating an impact plate onto an acceptor charge, or for driving a stress wave into a deflagration-to-deton transition charge]

31) G. Bjarnholt & R. Holmberg, "Expansion Work Provided by an Underwater Explosive Detonation", Explosifs 31 (1), 12-22 (1978) & CA 89, 45927 (1978) [The absolute work done in expansion by HMX has been calcd by the authors from exptl data and is shown, together with associated energy change parameters, in Table 6:

Table 6
Expansion Work Calculation Together with Associated Parameters Provided by Underwater Detonation Data for HMX (Ref 31)

Charge Wt, kg	0.340
Initiation By	6g PETN Booster + No 8 electric detonator
Charge Shape	As an Erlenmeyer Flask/ Detonator in neck of flask
Shock Energy Generated, MJ/kg	1.40
Bubble Energy, MJ/kg	2.33
Deton Press, GPa	13.4
Heat of Deton (- ΔH_d), MJ/kg	5.76
Expansion Work, MJ/kg	5.09

32) R.B. Cundall et al, "Vapor Pressure Measurements on Some Organic High Explosives", *J-ChemSoc, Faraday Trans I*, **74** (6), 1339-45 (1978) & *CA* **89**, 181933 (1978) [Equilibrium vap press were detd for various expls by the Knudson cell technique. The data for HMX follows the Clausius-Clapeyron eqtn. The values detd for the const A and B in the eqtn, $\log_{10}P = A - (B/T)$, plus the std enthalpy, entropy and Gibbs energy of sublimation from the authors' calcs are presented in Table 7:

Table 7
Thermodynamic Values for HMX as Calculated
by Cundall et al from
Knudson Cell Measurements (Ref 32)

Clausius-Clapeyron Constants	
A	12.98
B	8407
Temp Range, °C	141.8-206.2
Enthalpy, (ΔH°), KJ/mole	161.0 \pm 0.3
Entropy (ΔS°), J/mole-°K	152.7 \pm 4.0
Gibbs Free Energy, (ΔG°), KJ/mole	115.5 \pm 1.9

E. Manufacturing Processes and Treatments

33) T.C. Castorina & J.R. Autera, "Amino Nitrogen-15 Tracer Studies of the Nitrolysis of Hexamethylenetetramine", *PATR* **3116** (1964) [On completion of their study of the reaction of hexamine with AN and nitric acid, the authors conclude that the fragmentary precursor to HMX is methylene, $[(CH_2O)_x]$. They found that the fragment exists in sufficient concn to be the key component of the nitrolysis reaction because of the condensation of the equilibrated methylene fragments with the ammonium radical. Since the tracer study data so conclusively indicated an HMX precursor of the type $HOCH_2NHNO_2$, the authors recommend the prepn of HMX from monomethylene-contg compds] 34) W. Selig, "Stabilization of the Delta-Polymorph of HMX", *Explosivst* **17** (9), 201-02 (1969) & *CA* **72**, 68810 (1970) [Eighteen months ambient temp stability is claimed for δ -HMX produced as follows: Dissolve 150mg HMX in 5cc of N,N-dimethyl-p-toluidine by heating to 165° while stirring. Then stopper the reaction vessel and let cool to RT. After several days, decant the solvent and air dry to constant wt or dry in vacuo at 5-10

microns press at $\leq 45-50^\circ$. The crystals are purified by refluxing for several hrs in absol methanol, filtered and then air dried. The purified product showed a large DTA exotherm at 150°] 35) Y. Arnaud et al, "Thermal Stabilization of Explosive Compositions with Plastic Binder", *FrP* 1605235 (1973) & *CA* **81**, 108105 (1974) [A thermal stabilization process for an HMX contg PBX is claimed by the inventors. The PBX granules are first pretreated to eliminate moisture by drying at 50-60°. The process then consists of repeated refluxing with benz or C tetrachloride, HMX granules coated with 10% nylon, followed by drying at 60° for 36 hrs. The processed expl produces 0.10cc of gas/g on vac-heating at 130° for 20 hrs as compared to untreated granules which produce 3cc of gas/g] 36) R.W. James, "Propellants and Explosives", Noyes Data Corp, Park Ridge (1974), 348, "Direct Production of Beta-HMX" [The author reports on a patented process by R. Robbins & B.C. Boswell (USP 377-721 (1973)) for a continuous process to make HMX from hexamethylenetetramine (hexamine) by nitration with nitric acid. Mixts of glacial acetic acid, AN, acet anhyd and paraformaldehyde are used to provide the favorable reaction conditions. The temp is kept at 40-50° for the reaction and at 98-102° for the hydrolysis. The product is cooled to 30° for filtrn and then w-washed free of acid. The yield is claimed to be 0.80g of pure Beta-HMX/g of hexamine] 37) A. Reichel et al, "Phlegmatization of Crystalline Explosives", *GerP* 2308430 (1974) & *CA* **82**, 5787 (1975) [Safe mfg of HMX granules is claimed using a phlegmatization process involving emulsion coating of the crystn expl with approx 1-5% wax, vac drying and heating at temps in the wax melting range with stirring] 38) C.L. Coon & J.M. Guimont, "HMX and RDX Synthesis", Final Rept (1/74 to 12/31/74), SRI, Menlo Park, Contract No DAAA21-73-C-0487, Mod P00002 (1974) & *CA* **83**, 118022 (1975) [Prepn of HMX by nitrolysis of 1,5-diacetyl-3,7-dinitro-1,3,5,7-tetraazacyclooctane (DADN) is reported. The nitrolysis medium is prepd by adding 9.72g of 100% nitric acid to 3.24g (30 millimoles) of N_2O_5 at -30°. The mixt is then warmed to 0° and 1.45g (5 millimoles) of DADN is added all at once. The reaction mixt is then heated to 50° for one hr while it is being stirred. The resulting crude

HMX is pptd by pouring the reaction mixt into 300g of ice w. The product is removed by filtrn and dried in a vac over P_2O_5 to yield 1.21g of HMX contg 3% SEX, an 80% yield] 39) J.J. Vrolyk & R.D. Sheeline, "Nitration", USP 3822251 (1974) & CA 82, 19165 (1975) [The patent suggests that hexamine can be nitrated to HMX by turbulent mixing of the reactants in an inert liq carrier below its bp to control the temp of the reactions. Thus, an agitator is charged with approx 2cc of nitrating acid (50.7% nitric acid and 49.3 sulfuric acid) and 50cc of $n-C_7H_{16}$. At 10° , approx 1 g of hexamine is added and mixed under turbulent conditions. The max temp rise is reported as 10° during the turbulent nitration. Discrete layers are formed with the product being one of them]

40) I.J. Solomon & L.B. Silberman, "Cyclo-tetramethylenetetranitramine", USP 4086228 (1978) & CA 89, 62015 (1978) [The inventors claim that the prodn of HMX by nitrolysis of hexamethylenetetramine is increased by up to 28% over the prior art by modifying the sequence of reagent addn as follows: A small amt of hexamethylenetetramine is added to the acetic acid-acetic anhydride stirring medium prior to the addn of the nitric acid-AN nitrating soln with acetic anhydride. After ageing, the remaining hexamethylenetetramine and the nitrating soln are added and the reaction mixt aged again. Thus the conventional process gives an HMX yield of 67.3%, whereas an 80.4% yield is claimed for the invented process]

F. Chemical, Mechanical and Other Properties

41) M.E. Sitzman & S.C. Foti, "Solubilities of Explosives", JChemEngrgData 20 (1), 53-55 (1975) & CA 82, 100890 (1975) [Dimethyl formamide (DMF) is the best solvent for HMX, except that it forms a complex, and therefore is not recommended as being a *true* solvent. Butyrlactone and dimethylsulfoxide or their mixts are also excellent solvents for HMX, resulting in *true* solns]

42) D. Tabor et al, "Mechanical Properties of Energetic Materials", Final Tech Rept (7/76-1/77), Cavendish Lab, Cambridge (Engl), Contract DEARO-75-G-008 (1977) & CA 87, 154294 (1977) [Several properties of HMX are reported: during impact, the press-time curve exhibits a sharp drop with ignition at the instant of press drop; a coefficient of friction of 0.55 (crysts of HMX slide over smooth glass at a sliding velo-

city of 0.2mm/sec at 20°); and the Vickers hardness of a single HMX cryst is 41.3 ± 1 kg/sq mm at 20°] 43) C.C. Andrews & J.L. Osmon, "The Effects of UV Light on TNT and Other Explosives in Aqueous Solution", WOEC/C-77-32 NAVWEPSUPCNTR, Crane (1977) & CA 87, 55279 (1977) [A safe and efficient means of waste HMX disposal is described which includes acet soln of HMX followed by aq diln to 50,000 ppm, addn of 0.1% of hydrogen peroxide followed by exposure to UV radiation for 1 hr. The HMX is decompd into N, CO_2 and w]

G. Uses in Explosive Compositions

44) M. Finger et al, "Multiphase Extrudable Explosives Containing Cyclotrimethylenetrinitramine or Cyclotetramethylenetetranitramine", USP 3480490 (1969) & CA 72, 33910 (1970) [The inventors claim an extrudable, multiphase expl prepd by premixing HMX dispersed in a liq gem-dinitroaliphatic compd with stabilization additives. Thus, HMX (71.45), dinitropentnitrile (27.06) and colloidal silica (1.49%) were mixed, deaerated, and injected under press into a mold, and cured at about 70° . The product is reported as having a d of 1.70g/cc and a deton vel of 7980m/sec] 45) S. Fujiwara, "Explosive with Controlled Brisance", GerP 2039713 (1971) & CA 76, 47954 (1972) [The inventor proposes to use a mixt of HMX (70), Portland cement (30) and w (30p) to construct buildings. He claims that when the structure is outmoded it can be easily destroyed with a v small amt of noise and fragmentation because the inert fillers used in the compn have shock impedances of greater than 1400m/sec. A typical compn is reported as having a d of 1.64 g/cc, compression strength of 75-100kg/sq cm, deton vel of 7900m/sec, ρ_0 (deton vel)² of 104km/sec², Force of 7000 to 8000 kg-sq cm , and an ign temp of $280-90^\circ$] 46) M.A. Cook et al, "Explosive Composition for Use Under High-Pressure Conditions at Elevated and Normal Temperatures", SAfrP 7204378 (1973) & CA 79, 147873 (1973) [The inventors claim a liq expl useful for deep-well blasting at $\leq 10,000$ psig and temps of $15-350^\circ\text{F}$ which is stable at the higher temps for a reasonable length of time. The expl mixt consists of ammonitrotoluene (approx 22) suspension of HMX (approx 50 to 60) with up to 20% of a metal such as flake Al present to thicken, smooth and sensitize the

mixt. Initiation of the suspension can be accomplished by means of an RDX booster]

47) F.D. DePrisque & O. Naud, "Pliable Explosives", FrP 2166614 (1973) & CA 80, 122958 (1974) [The inventors claim a flexible (HMX) expl using an expl binder which has a deton rate of 8420m/sec as compared with 7200m/sec for HMX using an inert binder. The expl compn is HMX-Al (60-85) and an expl polymer mixt such as NG/NC/triacetin-4/1.5/1 g (40-15%). Prepn consists of degassing under vac a mixt of 160g NG and 40g triacetin, and then adding 60g of NC particles by thoroughly mixing to form a gel, with the NC well distributed thruout the gel. The gel is then degassed and 740g of HMX are added to form a homogeneous fluid which is subsequently degassed again, poured into molds and allowed to gel for 48 hrs at 60°]

48) J.M. Butler et al, "Explosive Composition Containing Lithium Perchlorate and a Nitrated Amine", USP 3723202 (1973) & CA 80, 49971 (1974) [A TNT-like expl, flexible, of low viscosity, easily milled and insensitive to normal handling shock because of the noncrystallinity of its Li perchlorate content even at low temps, is suggested by the inventors. Prepn consists of dispersing 600-900p by wt of HMX in a mixt of β -hydroxyethyl acrylate (30-80), ethylene glycol (20-70), Li perchlorate (133-200p by wt) plus 0.01-1 wt % of benzoyl peroxide. The mixt is then cured in 1-16 hrs at 60-120° to 48psi tensile strength and 50% elongation]

49) J. Rothenstein, "Flexible, Self-Supporting Explosive Compositions", GerP 2313886 (1973) & CA 80, 61726 (1974) [A tough, flexible expl is claimed which is settable at low temps. Prepn consists of mixing 75p of HMX with 10.75p of triacetin desensitizer, and then adding polyethylene glycol prepolymer (13), tolylene-2,4-diisocyanate dimer (1) and an antioxidant (0.25p). The mixt is then poured into molds and hardened at RT] 50) L.N. Roberts, "Liquid Explosive for Well Fracturing", USP 3825452 (1974) & CA 82, 46008 (1975) [The inventor claims a liq expl mixt contg HMX capable of penetrating rock fissures, which is cap and diameter insensitive. As an example of compn and useage he reports that a 6000-lb charge of thickened liq contg Nitromethane (42), TNT (42), HMX (4.2), Al powder (9.8) and NC (2p) was pumped into a 1-barrel/day, 4000-ft

deep oil well beneath an annular (3" diam opening) packing plug, a Compn B booster charge inserted, and the well sealed and stemmed with 600 lbs of sand and rock fragments. When fired, the well was blown free of stemming and rubble and productivity was increased to 40 barrels/day] 51) A. Reichel et al, "High Explosives", GerP 2335926 (1975) & CA 82, 173248 (1975) [A high performance expl series is claimed, formulated from HMX of 80-micron avg particle size, with binders such as a polyurethane resin and a desensitizer such as paraffin wax. The mixt is compressed into cylindrical casings at a press of 3 tons/sq cm. The properties of the expls are: comp strengths of 350-710kg/sq cm; d 1.68-1.79g/cc; deton rates of 8400-8690m/sec; friction sensy of 24 to > 36kg; and impact sensys of 0.5 to 1.5kg-m] 52) F.B. Wells, "Development of a Nonproprietary Flexible Sheet Explosive", PATR 4714 (1975) [Several versatile expl products have been developed by the author incorporating HMX. Their compn and properties are listed in Table 8. Prepn is by a pptn technique in which a lacquer consisting of NC, plasticizer, and stabilizer in butyl or ethyl acetate is added in a fine stream to a vigorously stirred suspension of the particulate expl and pigment in w. The mixing

Table 8
Composition and Properties of Flexible Sheet Explosive Containing HMX (Ref 52)

Composition and Properties	Values	
	Compn A	Compn B
RDX, %	33.4	-
HMX, %	29.6	63.0
Citroflex A4, %	28.2	28.2
NC, %	8.0	8.0
DPA, %	4.0	0.4
Pigment, %	0.8	0.8
Cap Sensy (consistent initiation using)	M6	M6
d, g/cc	1.5147	-
Deton vel, m/sec	7006	7005
Impact Sensy (PA app, 2kg wt), inches	17	16
Vac Stab (ml gas evolved in 40 hrs) at 100°	0.66	0.64
Vac Stab (ml gas evolved in 40 hrs) at 120°]	2.79	2.76

is conducted at elevated temps to rapidly drive off the solvents, with the product being recovered by filtration and drying. The recovered matl, consisting of discrete particles having a max diam of 1/16" to 1/8", are easily formed into any desired shape by rolling, extrusion, or pressing

53) F.B. Wells, "S-Trinitrobenzene as a Binder in Compression-Molded Explosive Compositions", *PATR* **4783** (1975) [It was found that the ideal HMX/TNB ratios required to provide compression-molded pellets that come close to the theoretical max d are 95/5 to 94/6 with no TNB loss at 5000psi compression press. It was also noted that the HMX used need not be of a very fine particle size to be successfully molded in the mixt] 54) J.R. Hendrickson & F.B. Wells, "Castable Composite Explosive Compositions Containing a Mixture of Trinitrobenzene (TNB) and Trinitroxylyene", *USP* 3994756 (1976) & *CA* **86**, 75497 (1977) [A castable composite expl which meets Mil Specs is claimed which contains TNB 26.25, Trinitroxylyene 3.75, and HMX 70 wt %] 55) F.B. Wells, "High-Energy Flexible Explosive. III. The Nitric Ester-Plasticized Nitrostarch Binder System", *ARLCD-TR-77043* (1977) & *CA* **87**, 203830 (1977) [An HMX contg flexible, w-repellant expl is reported with the following properties: bullet impact — no fire or expln; cap sensy — No 8 cap; cold temp, -10° ; d — 1.59g/cc; deton vel — 8219 m/sec; friction pendulum (steel shoe) no crackle, fire or expln; power by BalPend — 1.316 (TNT=1.0). The compn consists of HMX (68), Nitrostarch (14), Trimethylolethane dinitrate (18) and DPA (0.7%, added)] 56) S. Balwant et al, "A Survey on Cyclotetramethylene Tetra-nitramine (HMX)", *DefenseSciJ* **28** (1), 41–50 (1978) & *CA* **90**, 25603 (1979) [A review article with 146 refs on the properties of HMX and its use in expls]

Note: For addnl information on PBX formulations contg HMX see in Vol 8, P60-L to P77-L under "PBX"

II. Propellants

A. Analytical Models of Propellant Combustion and Detonation

57) N.S. Cohen & C.F. Price, "Combustion of Nitramine Propellants", *JSpacecraft&Rockets* **12** (10), 608–12 (1975) & *CA* **84**,

124116 (1976) [The authors claim an analytical model of the combustion of nitramine composite proplnts which explains observed burning rate characteristics and the effects of particle size, concn, and binder type in an entirely consistent manner. They conclude that there are two mechanisms responsible for observed shifts in pressure exponents, one involving surface structure and one involving flame structure. The surface structure and the monopropnt flame control the high pressure burning rate. The role of diffusion in nitramine proplnts, the authors contend, is more accurately described by a reactive process than by passive cooling of the monopropnt flame, and it controls the low pressure burning rate. They conclude their analysis by stating that "... The interreaction of the two mechanisms can produce what would appear to be unsystemic formulation effects on burning rate characteristics ..."]

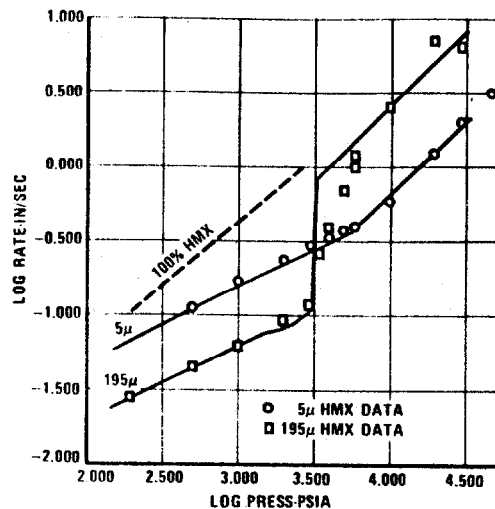

Fig 6 Effect of HMX particle size in HTPB propellant, 75% HMX (Ref 57)

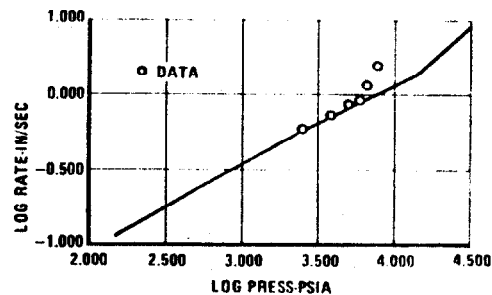

Fig 7 75% HMX in polyurethane propellant; 2μ HMX (Ref 57)

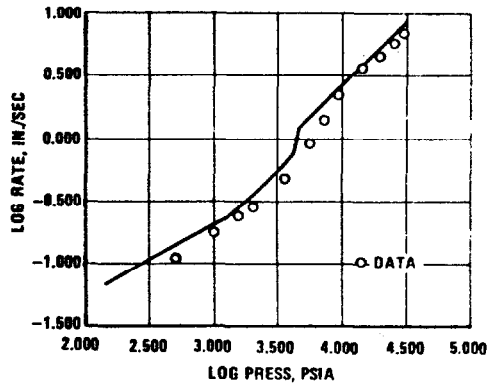

Fig 8 85% HMX in CTPB propellant; 100 μ HMX (Ref 57)

Cohen and Price's model was applied to several HMX proplnt formulations with the results shown in Figs 6, 7 and 8. The model information is represented by the solid line plot 58) D. Price & A.R. Clairmont, Jr, "Explosive Behavior of Simplified Propellant Models", *Comb&Flame* **29**, 87-93 (1977) & *CA* **87**, 55269 (1977) [The objective of the study was to determine deton vel (D), detonability and shock sensy as functions of loading d (ρ_0) and (critical) charge diameter (d_c) for a model proplnt compn contg AP/Al/wax/HMX (50/15/15/20%). From the data the authors conclude that (1) D varies directly (or linearly) with ρ_0 (2) d_c increases with increasing ρ_0 , (3) deton is diffusion controlled, (4) the proplnt cannot be dead-pressed (it will always detonate), (5) the proplnt is a group 2 expl, and (6) addn of 20% HMX to a proplnt model without expln at 55% theoretical max d lowers the relative Eyring reaction time (to deton) from 1.0 to 0.45 units]

B. Burning Rate Studies

59) Yu.M. Maksimov & E.I. Maksimov, "Burning of Condensed Systems in a Mass-Force Field at Moderate Pressures", *FizGoreniya-Vzryva* **8** (4), 517-23 (1972) & *CA* **78**, 99924 (1973) [The study showed that the burning rate of HMX remains unchanged at overloads of ≤ 900 gravities and ≤ 70 atmospheres] 60) N.S. Cohen, "Combustion of Nitramine Propellants", AFOSR, Lockheed Proplsn Co, Contract F44620-74-C-0031 (1974) (AD-783345) [A study of the burning rate of HMX/hydroxyl-terminated polybutadiene (75/25 wt %) proplnts has led to the formulation of an eqtn defining the relationship

between HMX particle size and proplnt burning rate:

$$T_m - T_0 = \frac{T_s - T_0}{1 + (r^2 D^2 / 12 \alpha_f \alpha_0) (K_0 / K_f)}$$

where: T_m = mp of HMX
 T_0 = ambient temp
 T_s = binder surface temp
 r = proplnt burning rate
 D = HMX particle size
 α_f = binder thermal diffusivity
 α_0 = HMX thermal diffusivity
 K = thermal conductivity (binder=f; HMX=0)]

61) L.H. Caveny et al, "Evaluation of Additives to Reduce Solid Propellant Flammability in Ambient Air", BRL Contract Rept **278**, Princeton Univ, Princeton, Contract DAAD05-72-C-0135) (1975) (ADA-019108), 15, 17, 73 [The authors' expts show that addn of 10% tritotyl phosphate is the most effective means of lowering the mass burning rate and reducing flammability limits of a control HMX composite proplnt. The proplnt compn consisted of HMX/-3,3'-bitolylene 4,4'-diisocyanate, hydroxyl-terminated polyethylene oxide of 400 mw, trimethylolpropane trimethacrylate and ferric acetylacetonate (75/25%)] 62) N. Kubota & T. Masamoto, "Flame Structures and Burning Rate Characteristics of CMDB Propellants", *ProcInt-SympCombustn* **1976**, 16, 1201-9 (1977) & *CA* **87**, 154283 (1977) [A conclusion reached resulting from a study of the flame structures and burning rate characteristics of composite modified double-base proplnts contg HMX, using techniques of photographic observation and temp profile determination, is that the HMX particles gasify at the burning surface of the proplnt. However, the flame structure and the temp profile in the fizz and dark zones are not altered by decompng HMX particle diffusion into the proplnt matrix of these zones, and the proplnt burning rate (as compared to AP as oxidizer) is slightly decreased by HMX addn]

C. Energetic Properties

63) B.K. Moy, "Thermochemical Evaluation of Advanced Gun Propellants", *AFATL-TR-73-244* (1973) [A theoretical, thermochemical proplnt-performance computer program was used to evaluate potential ingredients (including

HMX) for advanced gun proplnts, the program providing a good first approximation to proplnt parameters such as impetus, flame temp, and product gas molecular wt

HMX was first evaluated with hydrocarbon binders (Butarez, a carboxy-terminated polybutadiene, and Butyl rubber) because of their high thermal stability, in addition to the expected advantages of high impetus levels and low flame temps. In the Butarez binder, an 85% HMX level produced an impetus of 370000 ft-lbs/lb and a flame temp of 2540°K. At 84% HMX, the system was under-oxidized, at 86% the flame temp exceeded 2600°K. Because of a less favorable heat of formation, higher HMX loadings were required for the Butyl rubber system, ie, about 87% HMX and 13% Butyl rubber vs 85% HMX and 15% Butarez for an impetus of 370000 ft-lbs/lb. In the hydrocarbon formulations, the Butarez polymer appeared more attractive thermodynamically

The addition of HMX to NC at either the 12.6% or 13.15% N level increases the impetus as well as the flame temp. Replacement of NC (12.6% N) with 80% HMX increases the impetus from 347000 to 438000 ft-lbs/lb while only increasing the flame temp by about 800°K (from 3100° to 3900°K). Unlike the hydrocarbons, no combination of NC and HMX would produce flame temps below 3000°K. The mean molecular wts of the combustion products from NC/HMX systems were in the 24 to 26 range, while those from the hydrocarbon/HMX systems were in the 18 to 21 range

The author concludes that theoretically, the hydrocarbon/HMX formulations are superior to those with NC/HMX]

D. Ignition Studies

64) L. DeLuca et al, "Radiative Ignition of Double-Base Propellants: I. Some Formulation Effects", AIAAJ 14 (7), 940-6 (1976) & CA 85 126780 (1976) [The ign response to arc image radiative heating (5 to 100cal/sq cm-sec) of several HMX composite proplnts is shown in Fig 9

65) L.H. Caveny et al, "Solid Propellant Flammability Including Ignitability and Combustion Limits", BRL-R-1701 (1974), (AD 775795) [The authors found that the use of oxamide with high decompn temp HMX/polyurethane composite proplnts is effective in reducing flamma-

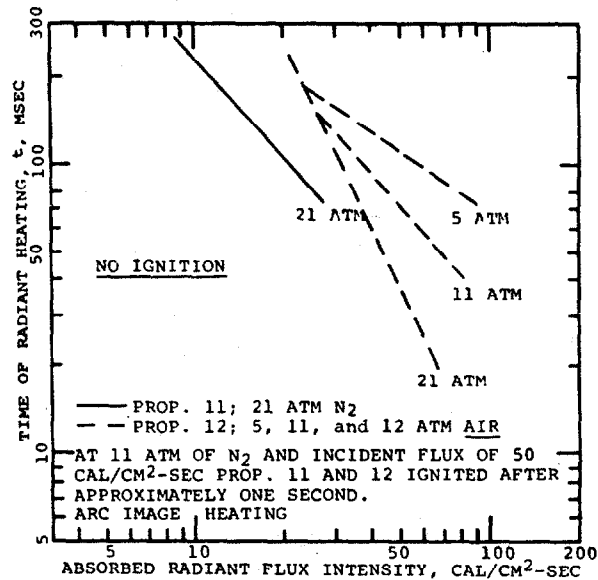

Fig 9 Arc-image ignition data for HMX composite propellants 11 and 12 in N_2 and in air showing resistance to ignition (Ref 64) ^a

Footnote to Fig 9

- a - Propnt compns, where PU is polyurethane:
 11. High energy proplnt (85% HMX, 15% PU)
 12. Cool proplnt (75% HMX, 15% PU, 10% oxamide)]

Table 9
 Time to First Flame Ignition of Oxamide-Containing HMX Propellants Using a Heat Source Consisting of an Acetylene Flame 1.7 cm in Length (Ref 65)

Propellant Compositions, %	Time to First Flame, Secs
HMX (75), Polyurethane (15), Oxamide (10)	18
As above but with a 0.03cm thick outer layer of 50% Oxamide	24
TAGN (60.0), HMX (10), Tufflex (25.5) . . .	4.5
References:	
Brass case 0.025cm thick (Ball pdr proplnt)	10.5
100% Clean Cotton Cloth	2
As above but soiled with Pwdrd C	4]

bility as shown in Table 9. The ign limits of these proplnts is well above the ign limits of

materials used as flammability refs, such as conventional clothing materials (clean or soiled) and ball powder proplnt protected by a brass case

E. Propellant Concepts

66) O. Heiney, "Advanced Gun Propellant Concepts", **AFATL-TR-73-28** (1973) [The author considers HMX oxidizer proplnt to be a major USAF step forward toward less expensive proplnt contg RDX which are 1/3 less costly. He considers this program to be important because low flame temp formulations contg nitramines such as HMX or RDX reduce gun barrel erosion, allow for the use of Al or plastic cartridge cases, and will make possible hypervelocity projectile firing from operational aircraft guns]

F. Propellant Manufacturing Processes

67) J.P. McDevitt & M.S. Chang, "Solvent Process for Production of Composite Propellants Using Hexane and Cyclotetramethylene Tetranitramine (HMX)", USP 3834957 (1974) & CA **82**, 75157 (1975) [A proplnt claimed to be useful in cartridge activated devices is prep'd by mixing together for 5 mins under vac, polyglycol adipate (223.6), Kopox-170 (29.9) and ferric acetylacetonate (0.9g), and then adding the following ingredients with 3 mins of mixing for each addn: HMX (436.2) having an avg particle size of 150 microns (previously wetted with 289.1g of n-hexane), HMX (817.6) having an avg particle size of 25 microns (previously wetted with 545.1g of n-hexane), K perchlorate (272.6) and Cu chromite (36.4g). The compn is then mixed for 25 mins, the n-hexane removed under vac and collected. The total mixing process is performed at 93–123°F. The proplnt is then removed from the mixer, extruded and cured at 203°F for 3 days]

G. Use in Propellants

68) F.A. Marion & H.J. McSpadden, "Feasibility Study of Thermoplastic Gun Propellant", **AFATL-TR-73-142** (1973) [The report describes an attempt to use an acetal resin (Celanese Corp "Celcon") and HMX to form a proplnt. The use of this mixt in proportions of 30–80% HMX was found not to be feasible because of lower than expected impetus, low burning rates and high burning rate exponents. However, the authors recommend the thermoplastic material as a candidate for use as cartridge case or closure material because of the high temp

stability evidenced, and the energy contribution to the proplnt system on combustion]

69) S. Kiname et al, "Mixed Solid Propellants", JapP 7430515 (1974) & CA **81**, 51892 (1974) [The inventors claim a rocket proplnt contg HMX with improved combustibility and stability. Thus, Amm perchlorate (40), NC (25), NG (35), HMX (30), DPA (2), ethyl centralite (2), Al powdr (20) and triacetin (5p) are mixed, de-aerated at 3 torr, molded and hardened at 60° for 48 hrs to obtn a proplnt 10cm in diameter by 20cm in length contg no air bubbles. Storage at 50° for 45 days showed no changes]

70) M.S. Chang & J.U. Lowe, "Temperature Resistant Propellants Containing Cyclotetramethylenetetranitramine", USP 3756874 (1973) & CA **80**, 5437 (1974) [The inventors suggest the use of 1:2 to 19:1 mixts of HMX/K perchlorate as an oxidizer together with 12 to 25% mixts of a binder such as bisphenol A diglycidyl ether or polyglycol adipate, and a burning rate modifier such as Pb salicylate or Pb chromate to yield a clean burning proplnt suitable for use in cartridge activated personnel escape devices. Several of these proplnt compns and their properties are shown in Table 10

Table 10
Compositions and Properties of Two
Temperature-Resistant Propellants
Invented by Chang & Lowe (Ref 70)

Compn and Properties	Values	
	Compn 1	Compn 2
HMX, %	69	69
K perchlorate, %	15	15
Polyglycol adipate, %	14	16
Pb chromate, %	2	—
Autoign temp (DTA), °F	452	457
d, g/cc	1.846	1.618
Impetus, 10 ⁶ in-lb	4.3	4.4
Vac Stab at 120° for 40 hrs, cc/g	0.31	0.54
Wt loss in 24 hrs at 302°F, %	0.63	0.30]

71) F.H. Bell, "Wafer Gun Propellant", USNatnl-TechInform Rept, Thiokol Chem Corp, Brigham City (1973) (AD 771651/76GA); USGovtRep-Announce **74** (5), 159 (1974) & CA **81**, 5170 (1974) [The author reports on a plastic composite solid proplnt contg HMX. The proplnt is

punch-pressed from a dry powder and then oven-cured. The wafer configuration permits early variation of the burning web by simply changing the pressing dies. The mfg process is adaptable to high volume production]

72) S. Kiname et al, "Smokeless Solid Propellant Containing Cyclotetramethylenetetranitramine", JapP 7435519 (1974) & CA 81,93624 (1974) [A smokeless solid propellant is claimed which when combusted in a test rocket motor at a press of 70kg/sq cm gives a specific thrust of 225 secs and a press index of 0.39. Prepn consists of mixing AN (27), NG (35), NC (27), triacetin (10), DPA (1) and HMX (30p) with subsequent vac defoaming and pour-molding at 50° for 48 hrs] 73) W. Zetzl & H. Schubert, "Non- or Difficultly-Flammable Cartridge and Propellant Charge for Caseless Ammunition", GerP 2246588 (1974) & CA 81, 93617 (1974) [The inventors claim a propellant with a v smooth surface, low mw and good mechanical stability. Thus, HMX (75.00), polyetherpolyol (9.25), diphenylmethane-4,4'-diisocyanate (14.35) and C trichlorofluoride (1.40%) are homogenized in a fast kneader at RT for 6 mins, and then poured into molds and allowed to harden at RT]

74) D.C. Sayles, "Propellant with Acrylate Copolymer Binder and Butanetriol Trinitrate Plasticizer", USP Applic B64868 (1975) & CA 82, 158374 (1975) [The inventor claims a smokeless propellant with a specific impulse of 265.1 lb-sec/lb-m with the following formulation: 95/5 ethyl acrylate-acrylic acid copolymer (4.6), butanetriol trinitrate (12.85), 1,2,3-tris-[1,2-bis(difluoroamino) ethoxy] propane (12.85), HMX (48.5), AP (19.2), diepoxydicyclohexyl carboxylate (1.5) and carbon black (0.5 wt %)] 75) J.E. Flanagan & V.E. Haury, "Propellant Powder", GerP 2449776 (1976) & CA 85, 162919 (1976) [The inventors claim an HMX-contg propellant for rapid-fire 20mm weapons with an isochoric flame temp of 2118°K, a mw of 17.78, a specific impulse of 101000kg-m/sec, and stability indicating no decompn after 7 days at 75° with the following compn: HMX (20), triaminoguanidine ethylenedinitramine (55), ethyl cellulose (10), trimethylolthane trinitrate (15 wt %)] 76) O. Prigent, "Propellants Having High Specific Impulse and Low Attenuation Effect on Radioelectric Waves", AGARD Conf Proc 194, 16 (1976) & CA 86, 123907

(1977) [Experimentation has produced a high specific impulse propellant compn whose exhaust is transparent to 10GHz radar waves. The compn incorporates as principal ingredients Amm perchlorate 74 and HMX 15%]

Note: Addnl information on the use and properties of HMX in propellants can be found in Vol 8, P408-L to P410-R, P416 (Table 19), P434 (Table 30), and P451-R to P452 (Table 54), under "Propellants, Solid"

III. Pyrotechnics

77) A.F. Taschler & S.M. Kaye, "Electrostatic Sensitivity of 95/5 HMX/Titanium . . .", PA-FRL-TN-9 (1961) [A mixt contg 36 micron HMX and 7 micron Ti exhibited a minimum electrostatic sensy for ign of 0.0010 Joules (5.6% igns), a 50% pt of 0.0036 Joules, and a 100% ign pt of 0.0160 Joules]

Tetranitro-oxanilide (TNO). See in Vol 8, O36-L to O37-R

2,3,4,6-Tetranitrophenylmethylnitramine.

(m-Nitrotetryl; N-Nitro-N-methyl-2,3,4,6-tetranitroaniline; or N-Methyl-N,2,3,4,6-pentanitroaniline). $C_7H_4N_6O_{10}$; mw 332.17; N 25.31%; OB to CO_2 -28.9%; monoclinic prisms; mp 145°, 145-146°, 146-147° (separate values) with decompn. Prepn is by nitration of m-nitromonomethylaniline. The compd exhibits a deflagration temp range of 162-175°, and evolves nitrous acid after 2 hrs at 60°. Power by Trauzl block expansion is 120% PA; Q_C 2453cal/g; and Heat test values are:

Test temp, °C	% Weight loss		Expln in 100 hrs
	1st 48 hrs	2nd 48 hrs	
75	0.90	3.24	None
90	7.02	1.78	None
100	8.62	1.29	None

It has an impact sensitivity (FI) that is 48% PA, or, using a Kast app with a 2-kg wt, no-fire is 19cm vs 51-53cm for Tetryl; all-fire is 36cm vs > 60cm for Tetryl. With the PicArsn app a

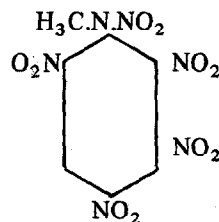

sensy of 6" is obtained for a 14mg sample, using a 2-kg wt. The nitramine gives a 100° vac stab test value of 11+cc of gas evolved in 28 hrs from a 1 g sample

The nitro group in the 3-position is readily removed by hydrolysis. Since monomethylaniline, on nitration in strong sulfuric acid furnishes some m-nitromonomethylaniline, crude Tetryl made from dimethylaniline contg monomethylaniline will contain m-Nitrotetryl as an impurity (Ref 2)

Refs: 1) Beil 12, 771, (372) & [428]

2) Davis (1943), 178 3) Blatt, OSRD 2014 (1944) 4) S. Helf & K.G. Ottoson, "Tests of Explosive Compounds Submitted by Arthur D. Little, Inc", PATR1750/1 (1949)

Tetranitrophenylnitramine. See in Vol 8, P243-L and R

Tetranitrosulfoxydiphenylamine. See in Vol 5, D1441-L and R under "2,4,5,7-Tetranitrodiphenylamine-Sulfoxide"

3,5,3',5'-Tetranitro-4,4'-Tetramethyldiaminobiphenyl (or TNTMB). $C_{16}H_{16}N_6O_8$; mw 420.38; N 20.0%; OB to CO_2 -121.79%; orange plates; mp 282°. Prepn is by addn of dimethylaniline to nitric acid without cooling. TNTMB is found as a benz insol impurity in Tetryl. It has an impact sensy of 10" using a 2-kg wt

Refs: 1) Beil 13, 237 2) Blatt, OSRD 2014 (1944)

1,3,5,7-Tetranitro-1,3,5,7-Tetrazacyclooctane (or Octahydro-1,2,5,7-Tetranitro-1,3,5,7-Tetrazocine). See under "Cyclotetramethylenetetranitramine . . . or HMX" in Vol 3, C605-R to C610-R and update in this Vol under "1,3,5,7-Tetranitro, Octahydro-1,3,5,7-Tetrazocine"

Tetra (2-Nitroxyethyl) Ammonium Nitrate. $(O_2N.O.CH_2CH_2)_4.NNO_3$; mw 436.0; N 19.30%; OB to CO_2 -33.0%; cryst; mp 127-29°, 137-38° (sep values). Sl sol in w. Prepn is by nitration of tetra (2-hydroxy ethyl) amm nitrate or tetra

ethanol amm hydroxide with concd nitric acid at < 25°. The compd has a deton rate of > 8000 m/sec at d of 1.6g/cc; an expln temp of 175-80°; a Q_C^y of 2637cal/g; an impact sensy of 42cm using a 1-kg wt (32cm RDX); power by BalMort 138% TNT, and by Trauzl test 157% TNT, or 420cc vs 480cc for RDX

Refs: 1) Beil, not found 2) E. VonHerz, GerP 630079 (1936) & CA 30, 5794 (1936) 3) Blatt, OSRD 2014 (1944)

Tetraoxymethylene Diperoxide. See under "Cyclodioxymethylene Peroxide" in Vol 3, C594-L

Tetrapentaerythritol and Its Decanitate Derivative, Tetrapentaerythritol.

$[(CH_2OH)_3C.CH_2.O.H_2C]_3.C.CH_2.OH$; mw 490.62; white cryst; mp 234°. V sl sol in hot w; v v sl sol in cold w. Prepn is by fractional crystn from hot w of impure pentaerythritol. It is the parent compd for the Decanitate presented below

Tetrapentaerythritol Decanitate.

$[(O_2NO.CH_2)_3C.CH_2.O.H_2C]_3.C.CH_2.O.NO_2$; mw 940.56; N 14.90%; OB to CO_2 -39.12%; white cryst; mp 70°. V sl sol in acet and ethylene dichloride; sl sol in ethanol, benz, and chl; insol in eth. Prepn is by adding with stirring 1 p of tetrapentaerythritol to about 10p of 98% nitric acid at from -5° to 5°. After stirring for 20 mins, the resulting mixt is poured with vigorous stirring into about 5 times its vol of ice w. The pptd Decanitate is then w-washed, neutralized and crystd from 1:1 acet-ethanol

The Decanitate is a powerful expl, v insensitive to impact (it is not detonated by a 2-kg wt dropped 100cm), with satisfactory thermal sensy. The inventor, Wyler, suggested that it be incorporated into safety expls such as a mixt of 5-35p to each 100p of AN. Also, because of its adhesiveness towards salts such as AN, he suggested that it could be used to coat AN as a superior waterproofing agent. Moreover, Wyler reports that the Decanitate sensitizes AN when used as a coatant

Refs: 1) Beil, not found 2) J.A. Wyler, USP 2427899 (1947) & CA 42, 764 (1948) 3) Ibid, USP 242957 & CA, ibid

1,4,7,10-Tetrapicrylhexamethylene-1,4,7,10-Tetramine, 1,10-Dinitro. $C_{30}H_{20}N_{18}O_{28}$;

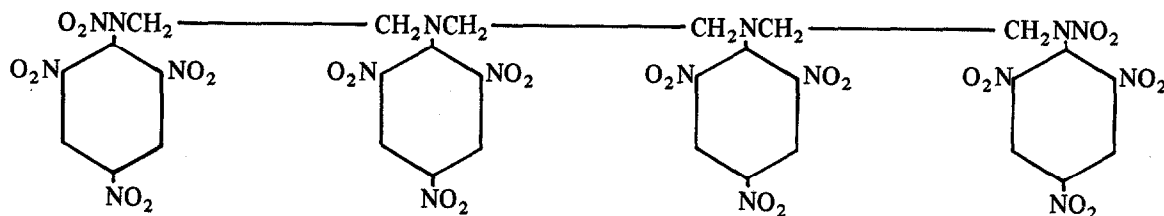

mw 1080; N 23.3%; OB to CO_2 -62.2%; mp 159° (decompn). Prepn is by condensing triethylene tetramine with picryl chloride and nitrating the product. Purification is difficult

Its impact sensy is 1.4 TNT (ie, more sensitive than TNT), and its Pb block expansion value is 122% TNT

Refs: 1) Beil, not found 2) Anon, Canadian Report on CE-12 (1 April to 1 June 1942)
3) Blatt, OSRD 2014 (1944)

Tetra (2,4,6-Trinitrophenylnitraminomethyl) Methane (or Tetratetryl).

$[(NO_2)_3C_6H_2.N(NO_2)CH_2]_4C$; mw 1156; N 24.2%; OB to CO_2 -47%; cryst; mp 117° , decompn at 140° . Prepn is by nitrating tetra-(2,4-dinitrophenylaminomethyl) methane. The compd explds when heated in a sealed tube

Refs: 1) Beil, not found 2) Blatt, OSRD 2014 (1944)

Tetravinyllead. $C_8H_{12}Pb$; mw 315.40; mp, explds violently on heating. Prepn is by reacting Pb(II) chloride and vinylmagnesium bromide in tetrahydrofuranhexane. The product is isolated in 80% yield by steam distln

Refs: 1) Beil, not found 2) A.K. Holliday et al, Chem&Ind, 1699 (1968) & CA 70, 47560 (1971) 3) L. Bretherick, "Hdbk of Reactive Chemical Hazards", CRC, Cleveland (1975), 554

1,4,7,10 Tetrazadecanes, Nitrated. See in Vol 2, B129-L to B130-L

TETRAZENES

Tetrazene (Tetrazen in Ger) is a collective name for derivatives of compds contg 4 nitrogens in a straight chain, such as **Tetrazene (1)**, $R.N:N.NH.N:R.R$, and **Tetrazene (2)**, $R.R:N.N:N:N:R.R$, where R is any alkyl or aryl radical

Tetrazenes (1) were formerly called **Diazo-hydrazides** by Wohl and Schiff (Ref 3), while **Tetrazenes (2)** were called "**Tetrazones**" by Fischer (Ref 2)

Tetrazenes of type (1), which had only two hydrogen substitutions, such as $R.N:N.NH.NH.R$, were called **Buzylenes** (See Vol 2, B394-R)

It appears that the first tetrazene ever prepd was the so-called "**dimethyldiphenyltetrazene**", prepd by Fischer in 1878 (Ref 2, p 172). The next tetrazene, called "**tetraethyltetrazone**", was also prepd by the same investigators

From that time until the present very many tetrazenes have been prepd and some of them proved to be expl

One of the most important expl tetrazenes is the so-called "**Guanylnitrosoaminoguanyltetrazene**" (see below). This compd has found some use as a primary and initiating expl. Instead of giving some abbreviated name, eg, "**Guanyltetrazene**", to this expl, the Germans initially called it simply "**Tetrazen**". This was Anglicized to "**Tetracene**". Tetrazenes form numerous derivatives, some of them expl. As the present nomenclature of tetrazenes, as well as of combinations of them with tetrazines, tetrazoles, triazines, triazoles etc, is very confusing, it is proposed to use a method (presented next), which might be called a combination of the German and English methods

Refs: 1) Beil 4, 579; 26, 74 2) E. Fischer, Ann 190, 172 (1878) 3) A. Wohl & H. Schiff, Ber 33, 2743 (1900) 4) E. Fischer, Ber 43, 3500 (1910) 5) K.A. Hofmann & H. Hock, Ber 44, 2946-47 (1911) 6) W.H. Rinckenbach & O.E. Burton, Army Ordn 12, 120 (1931) & CA 25, 5770 (1931) 7) A. Stettbacher, Nitrocellulose 7, 141 (1936) & CA 30, 8165 (1936) 8) R. Walbaum, SS 34, 128, 162-63, 197-201 (1939) 9) CondChemDict (1977), 852

Tetrazene Nomenclature. In order to differentiate between various kinds of tetrazenes it has been customary to designate the nitrogen at one end of the chain as N, and that at the other end as N'. In this method, however, there is no provision for naming the compd if a radical is attached somewhere in the middle of the tetrazene chain (the same applies to the hexazadienes) *Note:* In some Ger works, the nitrogen of tetrazenes is marked 1,2,3,4 and no method has been provided to differentiate these numerals from those used in radicals such as benzene, pyridine, triazole, tetrazole, etc

It seems that it would be less confusing to designate each member of the tetrazene ring by a Roman numeral. In this case, nitrogens of tetrazene (1) would be numbered as

I II III IV

R . N . N . N (R) . NRR, while those in tetrazene (2) as

I II III IV

RR . N . N . N . N.RR

The same rule would apply to derivatives of triazenes R . NH . N . NR or R'N . N . NH . R

I II III I II III

pentazadienes R . N . N . NH . N . N.R

I II III IV V

hexazadienes R . N . N . NH . NH . N . NR and

I II III IV V VI

octazones R . N . N . N(R) . N . N . N(R) . N . N . R

I II III IV V VI VII VIII

In order to make the nomenclature more uniform, the group .N.N., commonly called "azo", will be called "diazene"

When the compds mentioned above are connected to substances like tetrazine, tetrazole, triazine, triazole, benzene, pyridine etc, there seems to be no definite rule for naming the resulting compds, and, although some of them have as many as 6 different names, none of them

appear to be simple enough. After thoroughly examining the nomenclatures used in the following sources, we came to the conclusion that the present systems are satisfactory for relatively simple compds, but not for complicated ones:

1) Beil, 16 & 26 2) A.M. Patterson & L.T. Capell, "The Ring Index", Reinhold Pub Co, NY (1940) 3) F.R. Benson, ChemRevs 41, 1-60 (1947)

For example, suppose it is necessary to name the following compd:

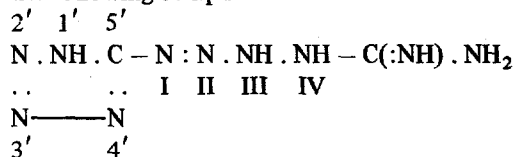

F.R. Benson, p 9, calls it 4-Tetrazolyl-5-tetrazene-guanyl-1, while the Germans called it either 1-Guanyl-4-tetrazolylidene-(5)-tetrazene or 1-Guanyl-4-tetrazolyl-(5)-tetrazene. None of these names are simple and comprehensive

If we adopt as a rule that any compd numbered from the left of the formula with numerals marked with a prime (') sign (such as 1', 2', etc) with the numbering done counter-clockwise, and any ring compd on the right hand side of the formula carrying plain numerals, such as 1,2 etc, and the numbering is done clockwise, the designation will be simplified

If we adopt Roman numerals for "tetrazene", then the name will be: (Tetrazolyl-5'), guanyl.I, IV-tetrazene or Guanyl(tetrazolyl-5') .IV,I-tetrazene. The figure 5', which follows the name of the tetrazolyl radical, signifies that the position 5' of the tetrazolyl is connected to the tetrazene. As the guanyl group -C(NH).NH₂ is always connected thru a C atom, there is no necessity to put a numeral after it. The sign . before I and IV was adopted from Beilstein and it means that two radicals are connected to positions I and IV of tetrazene

Note: If only one group is connected, the sign would be .; and if 3 groups are connected to the same compd, the sign would be :, etc

If some substituted group is present in tetrazole (for example, the amino group in position 1'), then we place 1' in front of the compd in which substitution has taken place and the compd will be "1'-aminotetrazole"

Let us now write the name of the following compd:

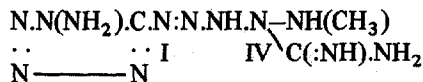

Using the same numeration as above, the name will be: (1'-Aminotetrazolyl-5'), methylamine, guanyl .1,IV,IV-tetrazene

Let us now suppose that it is necessary to write a name for the compd having the structural formula:

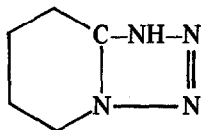

This already has several names (see Patterson and Capell, p 116, compd 712), such as Pyrido-2,1-C -s-triazole, Triazole-pyridine,2,3-Diazopyrrocoline, Benztriazole and 1,2,3-Benzisotriazole. Of these, only the first name is really scientific and would allow for writing the formula, once one learns what the letter C signifies. This system, however, not only uses numerals for positions, but also introduces letters, a,b,c,d,e, etc, for each side of a ring compd. This, in our opinion, is an unnecessary complication

Examining the formula of the above compd, it is observed that it is one of the **pyridotriazoles**, but as there are several pyridotriazoles, it is necessary to indicate the positions at which pyridine is connected to sym triazole

If we adopt the system of numbering each compd separately, and if the compd on the right side of the formula has simple arabic numerals (1,2,3, etc) counted clockwise, while the compd on the left side has primed arabic numerals 1', 2',3', etc, counted "counter-clockwise", then the formula may be represented as:

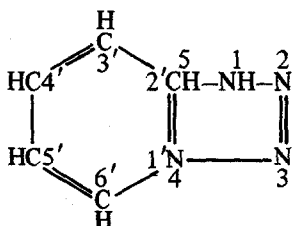

and the name proposed for this compd would be: **Pyrido-1',2',4,5-(sym-triazole)**

If this compd has an amino group in position 4' of the pyridine ring and a methyl group in position 1 of the tetrazole ring, then the name will be 4'-Aminopyrido-1',2',4,5-(1-methyl-sym-triazole)

As a final test of this method, let us write the name of the following compd:

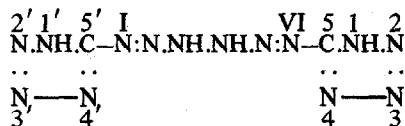

We call it **Di(tetrazolyl-5).1,VI-hexazdiene**; previous names were N.N'.Hexazadiene-di(5-tetrazole) and Bisdiazotetrazolyl-hydrazine

See also in Vol 1, Introduction II to VI under "Nomenclature"

The following are a selected group of tetrazenes and their derivatives

1, III-Diphenyl-Tetrazene (1) (Diazobenzene-phenylhydrazide, Benzoldiazo-phenylhydrazide or 1,3-Diphenyl-tetrazen-(1) (Ger)). $\text{C}_{12}\text{H}_{12}\text{N}_4$; mw 212.28; N 26.40%; OB to CO_2 -226.12%; pale yel cryst from eth; mp 71° (with decompn). V sol in eth, benz and acetic acid; sl sol in ethanol; not sol in dil acids and alkalies. The compd explds on heating
Refs: 1) Beil 16, 746 2) R. Stolle, JPrakt-Chem 2, 66, 336 (1902) 3) Ibid, JCS 84 (Abs 2), 100 (1903)

Guanylnitrosoaminoguanyltetrazene and Derivatives (GNAGT; Guanyldiazoguanyltetrazene,4,9 Bis-(imino)-1,2,3,5,6,7,8,10-octaza-1-oxo-5-decene; [CA name (1)] 1-Tetrazene-2-carboximidamide, 4-(1H-tetrazo-1-5 yl)-monohydrate; [CA name (2)] 3-Tetrazene-2-carboxamide, 4-(1H-tetrazol-5-yl)-monohydrate; Tetracine or "Tetracene"). CA Registry No [31330-63-4 (or 9)]. See in Vol 6, G169-L to G172-R, and the following *Addnl Refs:* 1) H.R. Weisbrod, "Development of Method for Measurement of Sensitivity of Explosives to Friction", Final Summary Rept, Univ Match Corp, St Louis, Contract No DA-23-072-RRD-1397 (1961) [A Bruceton analysis of data obtd for Tetrazene using a falling pendulum steel shoe friction appar indicated a 50% pt of 38.800 lbs with the "no fire" level (0.1%) at < 14.800 lbs and the 99.9% pt at 100.000 lbs] 2) A. Schoenbeck & J.R. Duguet, "Tetrazene Crystal Modification by Nucleating Agents", FrP 1582964 (1969) & CA 73, 37096 (1970) [The inventors claim a

means of improving the density and pourability of Tetrazene by addition to the reaction mixture of 0.005–1% of a nucleating agent such as animal protein, vegetable gum, waxes, colloids and sol synthetic polymers. Thus, to a mixture of 10ℓ of 25% aq aminoguanidine sulfate and 5ℓ 30% aq Na nitrite are added 12.5ℓ of w, 150ml acetic acid and 25ℓ of 2% aq CM-cellulose; the mixture is heated to 55° and then chilled to precipitate the product]

3) H. Gawlick et al, "Percussion-Sensitive Priming Agents for Solid Propellant Charges", GerP 1805358 (1970) & CA **73**, 57645 (1970) [The inventors report complete detonation of 160mg of NC without residues by using 5mg of one of the subject patented primer compositions prepared from 50% Tetrazene and 50% NC by granulating and mixing these ingredients with organic solvents and dextrin. They suggest that these primers be used for ignition of annular caseless propellant charges in stud-driving or pin-setting tools]

4) A.F. Schlack, "Ammunition Priming Mixture", USP 3602283 (1971) & CA **75**, 119656 (1971) [The inventor claims a noncorrosive priming mixture for use with 7.62mm solid caseless cartridges which met all circa 1971 specifications. The mixture consists of Pb styphnate 30–40, Tetrazene 10–15, Ba nitrate 20–25, Pb dioxide 7–10, Sb trisulfide 5–10, Zr 7–10 and PETN 3–5 wt %]

5) B.D. Pollock & R.F. Gentner, "Impact Sensitivity of Wetted Primary Explosives as Determined by the Ball Drop Test", PATR **4311** (1972) [The authors report that "no fires" were observed in ten consecutive trials at a maximum drop height of 42 inches, using a 1/2 inch diameter steel ball weighing 8.35g, which was dropped on liquid-wetted Tetrazene specimens spread uniformly on a hardened steel block. The test liquids studied were Freon-TF 90%, Freon-10%, ethanol 95%, ethanol 50/w 50%, and w]

6) T.A. Olson & J.J. Scanlon, "Molding Plastic-Coated Nitrocellulose", USP 3679781 (1972) & CA **77**, 128637 (1972) [The production of primary charges consisting of compression molded grains of 80/20 wt% mixtures of Tetrazene and Mannitol Hexanitrate coated with 2 wt % plasticized polyvinyl acetate is claimed. The charge manufacturing process is reported to consist of heating the coated grains initially to 180–230°, followed by a compression molding step at 6000–10000psi. The resulting charges are claimed to retain their geometry and dimensions]

7) H. Bartels, "Modified Gap Test for the Determination of the Shock Wave Sensitivity of Igniting and Initiating", Explosivst **20** (7–8), 143–50 (1972) & CA **78**, 126457 (1973) [The author reports the results of a shock wave sensitivity test in terms of safe handling criteria. The materials tested were tech LA, Pb Trinitroresorcinat, Tetrazene, tech Pb picrate (40% Pb nitrate), 2 grades of Tetryl and tech NGu (safest)]

8) C.O. Williams, "Propellants for Bolt Driving Guns", GerP 3404459 (1973) & CA **79**, 147871 (1973) [The inventor claims storage-stable, highly sensitive propellant for bolt-driving guns consisting of NC and 5–10% Tetrazene]

9) G.A. Younger, "Investigation of a Quick and Simplified Method to Manufacture Tetracene", FA Rept **2093** (1973) [The author reports on a proposed Tetracene (Tetrazene) manufacturing process, requiring two hours time as a laboratory scale procedure, using aminoguanidine sulfate as the basic aminoguanidine salt. He concluded that the proposed process uses less materials, fewer operations and less equipment than processes using other aminoguanidine salts as a starting material and that the quality of the Tetrazene so produced is equal in all respects (chemical, physical and ballistic) to Tetracene made by other processes circa 1973]

10) G. Norwitz et al, "Thermal and Stability Study of Tetrazene Using Differential Scanning Calorimetry (DSC)", FA-TT-74038 (1974) [At DSC scan speeds of 0.625° to 10°/min, two large exothermic peaks are produced. The peaks are seen at increasingly higher temperatures as the scan rate is increased. At a scan rate of 80°/min, only one large sharp exotherm is produced. The authors conclude that the stability of Tetrazene is changed by the more rapid heating rate]

11) G. Heinz & G. Marondel, "Caseless Formed Propellant Powder Charge", CanP 968629 (1975) & CA **83**, 11086 (1975) [The use of Tetrazene is recommended in an impact sensitive powder to ignite a caseless propellant charge. The described device is claimed to be suitable for activating such equipment as stud-drivers, impact tools, operating mechanisms and quick acting switches]

12) J.J. Swatosh et al, "Blast Parameters of Lead Styphnate, Lead Azide and Tetracene", PATR **4900** (1975) [Table 1 presents the reported TNT equivalency data for Tetrazene]

13) S. Oinuma & Y. Mizushima, "Guanylnitroso-aminoguanidyltetrazine Compositions with Im-

Table 1
TNT Equivalency of Tetrazene

Expl Configuration	% TNT							
	$\lambda = 3$		$\lambda = 9$		$\lambda = 18$		$\lambda = 40$	
	P	I	P	I	P	I	P	I
0.65 lb, dry, in a 1 qt rubber beaker	20	25	25	30	25	35	30	35
About 10 lbs, wet ^a , in a bag	10	15	15	20	20	20	25	—

Legend: λ = Scaled Distance, ft/(lb)^{1/3}

P = Peak Press, TNT Equivalent, % TNT

I = Positive Impulse, TNT Equivalent, % TNT

Footnote to Table 1: a—Excess w/ethanol 50/50 soln drained off]

proved Antistatic Properties”, JapP 75132112 (1975) & CA 84, 108032 (1976) [The inventor claims improvement in the antistatic properties of Tetrazene thru the addn of graphite. Thus, 35ml of 20% Na sulfate is added to a mixt of 7.5g aminoguanidine sulfate and 30ml of a graphite dispersion, followed by a drop of 50% acetic acid. The mixt is then warmed for 3.5hrs at 60°, and then left overnight to yield Tetrazene 90.7 and graphite 9.3%. The dried product is reported to have an electrical conductivity of “ 6.7×10^6 (ohm-cm)⁻¹ at d 0.56g/cc”]

14) N. Prange, “Priming Formulation for Rim Fire Ammunition”, USP 3963543 (1976) & CA 85, 96637 (1976) [The inventor suggests the use of Tetrazene 5, a Styphnate 45, Pb dioxide 7, Ba nitrate 20–30 and ground amorph Zr dioxide (to replace glass) 13–23 wt % in a priming compn designed to decrease the incidence of deflagration during the final cartridge rim forming process] 15) R.E. Bentley et al, “Preliminary Evaluation of the Acute Toxicity of Desensitized Primer Compounds and Primer Waste Effluents to Representative Aquatic Organisms”, NTIS (1975), (AD-A026125) & CA 85, 187352 (1976) [The acute toxicity of Tetrazene to aquatic life is not caused by the high pH resulting from desensitizing the expl, but to Tetrazene per se. It was detd to be the most toxic material tested] 16) M.S. Kirshenbaum, “Response of Primary Explosives to Gaseous Discharges in an Improved Approaching Electrode Electrostatic Sensitivity Apparatus”, PATR 4955 (1976), (AD-A033118) & CA 87, 8167 (1977) [The author reports on a study using an approaching

needle electrostatic sensy appar operated in a spark mode (long duration discharge) as well as in the oscillatory or arc mode (short duration discharge) to examine the electrostatic initiation sensy of Tetrazene. He found that threshold initiation energy values are a strong function of the energy delivery rate and are considerably less in the spark mode than in the arc mode]

17) D. Tabor et al, “Mechanical Properties of Energetic Materials”, Final TR, Cavendish Lab, Cambridge (Engl), Contract DA-ERO-75-G-008 (1977), pp 26–39 [In a study of the thermal decompn of Tetrazene employing Differential Thermal Calorimetry, the authors report the determination of the specific heat of Tetrazene over a temp range of 290–410°K as 1585 ± 0.65 J/kg·°K versus 1630 J/kg·°K reported from literature refs; the heat of reaction as 930 ± 50 J/g for unsealed samples and 860 ± 40 J/g for sealed samples (literature ref values of 1192 or 2270J/g). Also reported is a value of E (decompn activation energy) from the equation $\ln(\text{time to expl}) = B + E/RT$; where R is the gas constant, T is the absolute temp and B is a constant; as 195 ± 17 kJ/mole. A supporting value of 198 kJ/mole was found using the Avrami-Erofeev equation, viz, $[-\ln(1-\alpha)]^{1/6} = kt$, where α = the decimal fraction of dissociated material and t = time to expln in minutes]

18) C.L. Scott & H.S. Leopold, “Stab-Initiated Explosive Device Containing a Single Explosive Charge”, USP 4024818 (1977) & CA 87, 87254 (1977) [The inventors claim the subject charge output is equal to 3 (ordinary) charge detonators. The charge compn is reported as Tetrazene

- 2–10, Hg-5-nitrotetrazole 90–98 wt %. 50% initiation energy is reported as 2.4, 2.2 and 1.8 inch-oz for loading pressures of 20, 40 and 60psi, respectively] 19) J.F. Kenney, "Lead Styphnate Ammunition Priming Mixture", USP 4029530 (1977) & CA **87**, 8725 (1977) [Tetrazene is suggested as the sensitizer in center fire (shotgun) primary mixts with gum arabic as the binder along with Pb Styphnate and Styphnic Acid. The process is claimed to be cheaper, safer, eliminating polluting wastes and giving improved percussion sensy] 20) D.C. Sayles, "High Nitrogen Content Gas Generant and Method of Producing Near-Neutral Combustion Products", USP 4023352 & CA **87**, 25522 (1977) [The inventor suggests replacing Na Azide with Tetrazene pellets as a means of generating pressurized high N content gases to expel inhibited red fuming nitric acid (IRFNA) from tanks in rocket motor systems. The pellets are prepd by dead pressing Tetrazene at 10000–30000psi, and in contact with IRFNA produce, it is claimed, higher vols of N and fewer undesirable by-products than Na Azide. It is also claimed that the Tetrazene pellets are stable and save wt in a rocket system] 21) M.S. Kirshenbaum, "The Effect of an Electric Field on Sensitivity of Primary Explosives", **ARLCD-TR-77026** (1977) [The author reports that Tetrazene may have become slightly more electrostatically sensitive after exposure to an electric field of variable, but sub-deton threshold intensity; ie, six cycles of one min on and one min off of an electric field with a strength of 64 kv/cm, but the results are inconclusive. It was found that the minimum initiation energy value of Tetrazene decreased from 6100 to 5400 ergs. No appreciable effect was noted when the same voltage was applied continuously for 220 mins or in 8 cycles of ten mins on and ten mins off] 22) G. Krien, "Thermal Decomposition of Tetrazene", *SympChemProblConnectedStab-Expls (Proc)* 1976, **4**, 371–76 (1977) & CA **87**, 203825 (1977) [The author reports a differential scanning calorimetry study on the decompn kinetics of Tetrazene. It was found that no simple set of kinetic eqtns can describe the thermal decompn of the compd. He concludes that the reason for the stability of Tetrazene at RT, in contrast to its instability at elevated temps, is its very high activation energy]
- 23) R. Bird & A.J. Power, "Thermal Decomposition of Tetrazene at 90°C", **MRL-R-710**, Australia (1978) [The authors report that Tetrazene is converted into 5-aminotetrazole in less than three days at 90°, thus losing its stab sensy property. Spectroscopic evidence indicates that the 5-aminotetrazole is derived from both the side chain (via guanyl azide) and the Tetrazole ring] 24) G.B. Franklin & C.F. Parrish, "Radiation Polymerized Priming Compositions", USP 4056416 (1977) & CA **88**, 52661 (1978) [The inventors claim that extrudable primers with good percussion sensy are prepd from Tetrazene 3.9–4.1, n-Pb Styphnate 32–42, Sb sulfide 14–16, Ba nitrate 30–33, powdered Al 6–8 and a binder 4.5–8%. The acrylate binder is radiation polymerized using a ⁶⁰Co γ-ray source at approx 5 Mrad strength] 25) E. Brandenberger et al, "Piercing Sensitive Igniter Mixture", *SwissP* 594578 (1978) & CA **88**, 138720 (1978) [The inventors claim a compn stable to deflagration at > 200° for 30 mins contg Tetrazene 2–8 and Pb Azide 98–92%, which can directly initiate Tetryl, Nitropenta, etc. Also suggested is the use of 10–40μ grain size Tetrazene in friction sensitive detonators] 26) R. Bird, "The Stab Sensitizing Action of Tetrazene", *TechNote* **362** (Limited Dist), Aust Mat'l Res Lab (1975) & CA **89**, 26999 (1978) [The author reports (from the CA abstract) an extremely sensitive priming mixt consisting of Tetrazene and Pb Azide. This mixt has a striker impact sensy of about 3 millijoules. The rationale used in the development of this compn is that since Tetracene, although having a low ign temp, is too soft to have a good stab sensy, it must be compacted with a hard primary expl such as Pb Azide to yield a compn with the stab sensy desired]
- Some addnl expl derivatives and salts of Guanyl Nitrosoaminoguanyltetrazine, other than those shown in Vol 6 are the derivatives and salts of a misnomer compd, "Diazoaminoguanidine" or "Aminoguanidinediazonium" (*Note:* For a brief explanation of this error in nomenclature see under "Aminoguanidinediazonium Hydroxide" in Vol 1, A210-R)
- "Tetracene" Chloride (Diazoaminoguanidine chloride or Aminoguanidinediazonium chloride). C₂H₇N₁₀Cl; mw 206.61; N 67.79%; OB to CO₂

–58.08%; colorl prisms or ndls; mp, explds. Prepn is by action of concd hydrochloric acid on diazoaminoguanidine hydroxide (see below). Explds on friction or heating to ca 140°

“Tetracene” Hydroxide (Diazoaminoguanidine hydroxide or Aminoguanidinediazonium hydroxide). $C_2H_7N_{10}OH$; mw 188.16; N 74.5%; OB to CO_2 –63.78%; colorl prisms; mp, explds. Prepn is by reaction of aminoguanidine nitrate ($H_2N.NH.C(:NH).NH_2.HNO_3$) with an aq soln of Na nitrite at approx –10°. The hydroxide explds on impact or heating to 135–40°. On reaction with Cu or Ag hydroxide the expl Cu or Ag salts are formed (See Vol 6, G172-R)

“Tetracene” Sulfate (Diazoaminoguanidine sulfate). $(C_2H_7N_{10})_2SO_4$; finely divided white powder. The sulfate forms a Ag salt which is v expl; $C_2N_{10}OSO_3.Ag_2SO_4$; mw 571.98; N 24.49%; OB to CO_2 +11.19%; cryst. Prepn is by treating an aq sulfuric acid soln of GNAGT with Ag sulfate in aq 20% sulfuric acid at RT
Refs: 1) Beil 3, (60) & [103] 2) K. Hofmann & R. Roth, Ber 43, 682–88 (1910) & CA 4, 1309 & 2465 (1910) 3) K. Hofmann et al, Ann 280, 131 & 138 (1911) & CA, not found

[(I-m-Nitrophenyl), III-phenyl, IV-carboxamide]-tetrazene (1) [(α -Ureide- α -phenyldiazoaminobenzene)-(3-Phenyl-1-[3-nitro-phenyl]-tetrazen-(1)-carbonsäure-(4)-amid; or 1-[3-Nitrobenzoldiazo]-1-phenyl-semicarbazid in Ger]. $(m-O_2N.C_6H_4).N.N.N(C_6H_5).NH(CO.NH_2)$; mw 280.31; N 27.48%; OB to CO_2 –165.53%; orange colored gelatinous substance while wet, becoming a yel amorph solid on drying; mp, expl decompn at ca 104°. Sol in ethanol and ethyl acetate; sl sol in eth and chl; insol in benz and petr eth. Was prepd by Bailey and Knox from 1-phenylsemicarbazide (Beil 15, 287) and 3-nitrobenzoldiazonium chloride-(1)
Refs: 1) Beil 16, 748 2) J.R. Bailey & L. Knox, JACS 29, 890 (1907) & CA 1, 2798 (1907)

[(I-m-Nitrophenyl), (III- α -“ethylisobutyrate”)- (IV-carboxamide)]-tetrazene (1) (Note: α -Ethylisobutyrate should really be something similar to “ethylisobutyryl”). It is an abbreviation for the radical $-C(CH_3)_2CO_2.C_2H_5$, commonly called “ α -Isobutyric acid ethyl ester”);

(α -Ureido- α -m-nitrophenylenediazoamino-i-butyric acid ester); (1-[3-Nitro-phenyl]-tetrazen-(1)-[carbonsäure-(4)-amid]-[α -iso-butter-säure-(3)-äthylester]; α -[1-(3-Nitro-benzoldiazo)-semicarbazino]-isobutter-säure-äthylester in Ger). $(m-O_2N.C_6H_4).N.N.N[C(CH_3)_2.CO_2.C_2H_5].NH(CO.NH_2)$; mw 318.37; N 24.85%; OB to CO_2 –145.74%; cream-white cryst. Sol in ethanol and ethyl acetate. Was prepd by Bailey and Knox from α -semicarbazineisobutyric acid ethyl ester (see Beil 4, 560) and 3-nitrobenzoldiazonium chloride-(1). Expl decompn at 133°

When this ester was treated with alcoholic KOH, bright vermilion colored narrow prisms were obtained, which expld at 166°. The analysis of this K compd showed that it was not the salt of the ester mentioned above, but the salt of 1-[3-nitrobenzoldiazo]-3,5-dioxo-6,6-dimethylhexahydro-1,2,4-triazine, also an expl compd

Refs: 1) Beil 16, 748 2) J.R. Bailey & L. Knox, JACS 29, 889–90 (1907) & CA 1, 2798 (1907)

[(I-m-Nitrophenyl), (III- α -propionic acid), (IV-carboxamido)]-tetrazene (1); [(α -Ureido- α -m-nitrophenylenediazoaminopropionic acid); (1-[3-Nitro-phenyl]-tetrazen-(1)-[carbonsäure-(4)-amid]-[α -propionsäure]-(3); or α -[1-(3-Nitrobenzoldiazo)-semicarbazino]-propionsäure in Ger]. $(m-O_2N.C_6H_4).N.N.N[CH(CH_3)CO_2H].NH(CO.NH_2)$; mw 276.28; N 28.38%; OB to CO_2 –121.62%; amorph substance; mp, expl decompn at about 128°. The compd was prepd by Bailey and Knox from α -semicarbazino-propionic acid (Beil 4, 557) and 3-nitrobenzenediazonium chloride-(1). It could not be purified by crystn because it decompd

It forms salts and esters, most of which are expl:

Potassium salt, $KC_{10}H_{11}O_5N_6$; mw 334.37; N 25.15%; OB to CO_2 –104.34%; vermilion-colored solid. Prepn is by treating the alcoholic soln of the above acid with alcoholic KOH

When freshly prepd and heated to 165°, it explds, but if the pure dry substance is allowed to stand for 24 hrs, its expln pt rises to 184° (Refs 1 & 2)

Ethyl ester, $O_2N.C_6H_4.N.N.N[CH(CH_3).CO_2.C_2H_5].NH(CO.NH_2)$; mw 324.34; N 25.93%; OB to CO_2 –133.19%; mp, decomp explosive-

ly at about 146°; crystals from ethyl acetate; the ester is sol in chl_f, ethanol and ethyl acetate; insol in w, eth and petr eth. The compd was prepd by Bailey and Knox by treating in aq soln at 0°, 3-nitrobenzoldiazonium chloride-(1) and α-semicarbazinopropionic acid ethyl ester (Beil 4, 557)

Propyl ester, (m-O₂N.C₆H₄).N:N[CH(CH₃).CO₂C₃H₇].NH(CO.NH₂); mw 324.36; N 21.60%; OB to CO₂ -147.98%; mp, decomps explosively at about 149°. The compd was prepd by Bailey and Knox from α-semicarbazinopropionic acid propyl ester (Beil 4, 557) and 3-nitrobenzoldiazonium chloride-(1)

Nitrile, (m-O₂N.C₆H₄).N:N.N[CH(CH₃).CN].NH(CO.NH₂); mw 277.17%; N 35.38%; OB to CO₂ -129.88%; yellowish ppt; mp, decomps explosively at about 133°. It was prepd by Bailey and Knox from α-semicarbazinopropionitrile (Beil 4, 558) and 3-nitrobenzoldiazonium chloride-(1)

Refs: 1) Beil 16, 748 2) J.R. Bailey & L. Knox, JACS 29, 885 (1907) & CA 1, 2798 (1907)

I-Phenyl (III-β-ethylpropionate), IV-carboxamide-tetrazene (1). (*Note:* "β-Ethylpropionate" (it really should be something similar to "β-Ethylpropionatyl") is an abbreviation for the radical -CH(CH₃)CO₂.C₂H₅, commonly called "β-proprionic acid ethyl ester"; -Ureido-4-phenyldiazaminopropionic acid ethyl ester, 1-Phenyl-tetrazene-(1)-carbonsäure-(4)-amid-propionsäure-3-äthylester; or 1-Benzoldiazo-semicarbazine-propionsäure-äthylester in Ger). (C₆H₅).N.N.N.CH(CH₃).CO₂.C₂H₅.NH(CO.NH₂); mw 279.34; N 25.09%; OB to CO₂ -168.99%; cryst from aq ethanol; mp, melts with expln ca 125°. Sol in ethanol, ethyl acetate and chl_f; sl sol in eth; insol in benz and petr eth.

Prepn is by reacting benzenediazonium chloride with β-semicarbazinopropionic acid ethyl ester
Refs: 1) Beil 16, 747 2) J.R. Bailey & L. Knox, JCS 29, 884 (1907) & CA 1, 2798 (1907)

I-Phenyl, III-Ethyl-Tetrazene (1). (III-Ethyl, I-phenyl-tetrazene (1), or 3-Aethyl-1-phenyl-tetrazene in Ger). C₆H₅.N.N.N(C₂H₅).NH₂; mw 164.24; N 34.12%; OB to CO₂ -214.32%; oily liq; bp, explds. Sol in eth and is decompd by alkalies. The compd was prepd by Fischer and Troschke in 1879 by introducing a benzenediazonium salt in a cold aq soln of ethylhydrazine. A very

unstable compd which deflagrates on rapid heating and forms salts which are also unstable

Refs: 1) Beil 16, 746 2) E. Fischer & H. Troschke, Ann 199, 306-07 (1879) 3) E. Fischer, Ber 43, 3500 (1910) & CA, not found
I,I,IV,IV-Tetraallyl-Tetrazene (2). (I,I,IV,IV-Tetraallyl-tetrazene; 1,1,4,4-Tetraallyl-tetrazene (2); or 1,1,4,4-Tetraallyl-tetrazene in Ger). (CH₂.CH.CH₂)₂.N.N.N.N.(CH₂.CH.CH₂)₂; mw 184.33; N 25.44%; OB to CO₂ -243.04%; pale yel liq with aromatic odor, acts as a narcotic; bp 113° at 752mm. Sl sol in w. Prepn is by reacting an ethereal soln of the diethyl-ester of azocarbonic acid (C₂H₅.O₂C.N.N.CO₂.C₂H₅) with N,N-diallylhydrazine [(C₃H₅)₂N.NH₂] at -10°. The reaction is reported by Diels as:
2(C₃H₅)₂N.NH₂ + 2C₂H₅.O₂C.N.N.CO₂.C₂H₅ →
2C₂H₅.O₂C.NH.NH.CO₂.C₂H₅ +
(C₃H₅)₂N.N.N.N(C₃H₅)₂.

The compd explds violently when heated above its bp

Refs: 1) Beil 4, [968] 2) O. Diels, Ber 56, 1936 (1923) & CA 18, 528 (1924)

Tetramethyl Tetrazene (I,I,IV,IV-Tetramethyl tetrazene; TMT; (CA name) 1,1,4,4-Tetramethyl-2-tetrazene; Tetramethyl-2-tetrazene; Tetramethyltetrazene; or 1,1,4,4-Tetramethyltetrazene). (CH₃)₂N₄(CH₃)₂; mw 116.17; N 48.24%; OB to CO₂ -192.82%; colorl to lt yel oil; fr pt -22.0°; b pt 125°; d 0.8895g/cc at 25°; RI 1.4625. Sol in org solvents such as ethanol, CCl₄ or n-hexane and dil aq acid solns; sl sol in w. CA Registry No [6130-87-6]. Prepn is by oxidation of an aq soln of 1,1-dimethylhydrazine hydrochloride with K bromate at 0 to 10°, followed by neutralization of excess acid with aq Na hydroxide soln. The yield (relative to the amt of oxidant used) is 75-86%. When heated appreciably above its bp (130°), TMT explds violently

TMT has a ΔH_f of 55.9kcal/mole. Open cup (hypergolic) ignition delay with perchloric acid is 1.6msec; with perchloryl fluoride it is 214.2msec. Since it is smoothly hypergolic with perchloryl fluoride, TMT would seem a good rocket fuel; however, it is considered logistically inferior to its closest competitor, UDMH, because it is prepd from UDMH

Refs: 1) Beil 4, 579 & (570) 2) W.R. McBride et al, "Potentialities of Tetramethyl-tetrazene as a Liquid Propellant", NAVORD

5419; NOTS 1679 (1957) 3) J.D. Clark, "Tetramethyl Tetrazene as a Rocket Fuel", NARTS L-17 (letter report) (No date)

Tetrazidocuprate Metal Salts. There are two specific salts of interest which are not mentioned in Vol 1, A533-R to A534-L under "Cupric Azide Complexes", viz:

Barium Tetrazidocuprate. $\text{Ba}[\text{Cu}(\text{N}_3)_4]$; mw 369.01; N 45.56%. The compd explds at 178–80°. Also, **Strontium Tetrazidocuprate.**

$\text{Sr}[\text{Cu}(\text{N}_3)_4] \cdot 3\text{H}_2\text{O}$; mw 373.35; N 45.03%.

This compd becomes a brisant expl only after heating and loss of w of crystn. The expln temp depends on the sample wt (or actually, the rate of heating); ie, 5mg explds at 190° in 0.5min, while 0.8g explds at 100° in 0.5 hr

Refs: 1) Gmelin, Syst Nr 60, Teil B, Lief 3 (1965), 1140 2) M. Straumanis & A. Cirulis, ZAnorgChem 252, 121–25 (1943) & CA 38, 1701 (1949) 3) Ibid, 9–23 (1943) & CA 38, 3563 (1944)

The Tetrazines and Derivatives

Tetrazines are heterocyclic, six-membered ring compds contg 4 N atoms that are remarkable for their high nitrogen content. They are characterized by their red color

Three types of tetrazines are possible, only the first two of them are known (vicinal and symmetric); the third (asymmetric type) has not been prepd to date:

1) *vic*, or 1,2,3,4-tetrazines- derivatives of

(6) (1) (2)

HC : N . N

..

HC : N . N

(5) (4) (3);

2) *sym*, or 1,2,4,5-tetrazines- derivatives of

(1) (2)

N . N

..

(6)HC CH(3)

..

N : N

(5) (4); and

3) *asym*, or 1,2,3,5-tetrazines- derivatives of

(1) (2) (3)

N . N : N

..

HC . N : CH

(6) (5) (4)

The derivatives of *vic-tetrazines* were obtd in 1888 by H. vonPechmann (Ref 4) by the oxidation of esazones and were called by him "oso-tetrazines" or "dihydotetrazines" (see also, H. vonPechmann and W. Bauer—Ref 5)

The derivatives of *sym-tetrazines* were first prepd by T. Curtius in 1888 (Ref 2) and were further investigated by A. Hantzsch et al (Ref 3)

No evidence has been found in the literature that the *asym-tetrazines* have ever been prepd (Refs 7 and 8)

An expl K tetrazine salt was prepd by Wood and Bergstrom (Ref 6) with the approx formula $\text{K}_2\text{C}_3\text{N}_4$; mw 158.26; N 35.41%; red cryst; mp, highly expl when heated. Not sol in ammonia. Prepn is by reacting an unspecified (*vic* or *sym*) tetrazine with K amide in liq ammonia at –40°

Refs: 1) Beil 26, 353, (111) & [212]

2) T. Curtius, JPraktChem 38, 557 (1888)

3) A. Hantzsch et al, Ber 33, 58 & 3668 (1900)

4) H. vonPechmann, Ber 21, 2754 (1888)

5) H. vonPechmann & W. Bauer, Ber 33, 644 (1900) 6) D. Wood, Jr & F.W. Bergstrom,

JACS 55, 3648–52 (1933) & CA 27, 5078

(1933) 7) J.G. Erickson et al, "The 1,2,3- and 1,2,4-Triazines, Tetrazines and Pentazines", Interscience, NY (1956) 8) CA literature search to date (1979)

Vicinal (*vic*) or 1,2,3,4-Tetrazine Derivatives.

There is only one expl *vic* derivative:

1-Nitroso-Phenyl-*v*-Tetrazine. $\text{C}_8\text{H}_9\text{N}_5\text{O}_2$; mw 207.22; N 33.80%; OB to CO_2 –142.84%; yel cryst; mp, explds about 120°. Peprn is by nitrosation of 2-phenyl-1,2-dihydro-*v*-tetrazine with nitrogen oxides

Refs: 1) Beil, not found 2) J.G. Erickson et al, "The 1,2,3- and 1,2,4-Triazines, Tetrazines and Pentazines", Interscience, NY (1956), 160–62

The other expl tetrazines consist of the parent compd, *sym*-Tetrazine and its derivatives:

Sym-Tetrazine (or 1,2,4,5-Tetrazine). $\text{C}_2\text{H}_2\text{N}_4$; mw 82.08; N 68.27%; OB to CO_2 –97.47%; dark purple-red prisms with volatile red fumes

that have an iodine-like odor; cryst data at -20° is a 5.23, b 5.79 & c $6.63 \pm 0.01 \text{ \AA}$ with $B=115.30' \pm 15'$ (Ref 3); mp 99° . Sol in org solvents and w. CA Registry No [290-96-0]. Prepn is by heating 3,6-dicarboxy-sym-tetrazine to 160° , or by reacting hydrazoformaldehyde-dihydrazon with Na nitrite in acetic acid. When heated with Ba oxide sym-Tetrazine explds violently It deflagrates when in contact with concd sulfuric acid

Refs: 1) Beil **26**, 353, (111) & [212] 2) T. Curtius et al, Ber **40**, 84-85 (1907) 3) F. Bertinotti et al, ActaCryst **8**, 513-14 (1955) & CA **49**, 15353 (1955)

3,6-Diamino-3,6-Dihydro-Sym-Tetrazine Dinitrate. See in Vol 5, D1135-L & R

3,6-Diamino-Sym-Tetrazine Hydrobromide.

(The parent deriv compd is listed in Vol 5, D1135-L). Yel leaflets with an expln temp of 120°

Ref: Beil **26**, (130)

3,6-Difluorenylidene-3,6-Dihydro-Sym-Tetrazine.

See in Vol 2, B143-L under "3,6-Bis (fluorenylidenedihydro)-sym-tetrazine . . ."

1,2-Dihydro-Sym-Tetrazine-3,6-Dicarboxylic Acid. See in Vol 5, D1267-L

Di(Tetrazolyl-5):3,6-(Dihydro-Sym-Tetrazine).

See in Vol 2, B157-R to B158-L, under "3,6-Bis (2H-tetrazolyl-5)-dihydro-1,2,4,5-tetrazine . . ."

Di(Tetrazolyl-5):3,6-Sym-Tetrazine. See in Vol 2, B158-L under "3,6-Bis (2H-tetrazolyl-5)-sym (or 1,2,4,5-) tetrazine . . ."

Octahydro-1-Acetyl-3,5,7-Trinitro-Sym-Tetrazine.

See under "1-Aceto-3,5,7-trinitro-1,3,5,7-tetra-cyclooctane . . ." in Vol 1, A49-R to A50-L

TETRAZOLES

The tetrazoles are characterized by a five-membered, doubly unsaturated ring consisting of one carbon and four nitrogen atoms in the order shown:

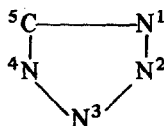

This general structure usually exists in the tautomeric forms shown next:

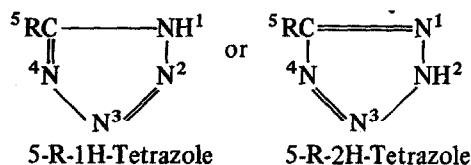

On the basis of the tautomeric formulas shown for 5-monosubstituted tetrazoles (where R is any substituent) there are three classes of monosubstituted and two classes of disubstituted derivatives (where the H is replaced). Also, there are fused ring tetrazoles of the 1,5-disubstituted class. In addn, there are salts and substituted derivatives which have 2,3-, 1,4- and 1,2-substituents. However, compds of ordn interest are usually 1,5-, 2,5- or 1,3-substituted. Bis expl compds may be connected at the 5,5'-positions. Bis expl salts may be connected at either the 1,1'- or the 5,5'- position with the (metallic) anion. (See in Vol 2, B157-L & R and below under the pertinent compds)

The majority of tetrazoles are crstn solids. There is considerable variation in thermal stability, viz, derivatives which melt above 150° do so with decompn, while 5-guanylaminotetrazole (Vol 7, G166-L) does not melt at 300°. In general, most of the tetrazoles are acids and often yield expl salts. The tetrazoles, in the main, can be looked upon as gas generators, useful where instantaneous or progressive pressure effects are required. They possess moderate brisance. However, their salts, which may detonate with extreme brisance, can be used as primary expls, as can 1- and 2-Methyl-5-Nitro Tetrazoles, which are delineated in this article

History of Use:

Rathsburg (Ref 1) patented the use of some expl derivatives and salts of the tetrazoles to re-

place Hg Fulminate in detonators, percussion caps, etc. Primers prepd with these materials were claimed to be stable, and to have the advantage that the compds could be subjected to high pressures without desensitizing the charge. A typical blasting cartridge formulation contained Tetryl (1.00), Pb or Cd Tetrylazide (0.15), and Pb Azotetrazolate (0.15g). In order to increase safety in handling, the tetrazoles may be granulated with paraffin or resin, with or without addn of cork meal. Another suggested procedure for desensitizing the tetrazoles was to intimately mix them with or co-ppt them from some solvent together with one of the following expls: Di or Trinitroresorcinol, Trinitrophenol, m-Dinitro- or o-Dinitrosobenzene, etc. During WWII, the Germans suggested replacing Ag azide and Hg Fulminate with the 5-Nitrotetrazoles of Ag and Hg. Work was performed in 1952-53 at NOL with the salts of Nitro- and Nitroamino-tetrazole and in 1955 at PicArnsn with the Halotetrazoles and 5,5'-Hydrazotetrazoles (Vol 2, B157-R and Vol 7, H211-R). Also, in the early 1950's, investigation of nitroguanylaminotetrazole (and its guanidinium salt) as ballistic modifiers in cool proplnt formulations was of sufficient interest to merit evaluation by PicArnsn and the Naval Ordn Lab (Refs 2a and 2b). Evaluation of amino- and iminotetrazoles as proplnt flash and smoke reducing energetic agents was also conducted (Ref 2c). In the 1960's work was done to improve proplnt initiation using the salts of Diazoaminotetrazole, Azotetrazole and the double salt of Pb Styphnate and Pb Nitroaminotetrazole (Vol 1, A257-R to A262-L, A659-R to A660-L, and below). Aminotetrazole has been suggested for use in pyrot compns contg Amm nitrate (Ref 3a). Currently, advances in rocket proplnts, anti-gun barrel wear proplnt additives, and match compn binders employing polyvinyl tetrazoles (see below under 5-Methyl-5-Vinyl Tetrazole), as well as the use of the well known expl sensitizer "Tetrazene" (qv in this Vol) (Refs 4 to 10), add sufficient incentive to continue exploration in the use of tetrazoles as important compds for energetic applications. Further evidence of their importance is the fact that the tetrazoles are considered to be standard or prototype expls having interchangeable juxtaposition substituents with easily measurable properties which can be cor-

related with energetic performance vs substituent site on the same ring structure. To this end, Tarver et al (Refs 7–9; 10) used both 1-Methyl-5-Nitrotetrazole and 2-Methyl-5-Nitrotetrazole (see below) in an attempt to identify those characteristics which contribute to their initiative action by correlating their physical and chemical properties (DDT behavior, heats of formation, bond energies, etc) with molecular structure. However, they were only able to present qual information and the obvious conclusion that DDT occurs at a more rapid rate in primary than secondary expls (where it can be predicted), claiming that a lack of firm basic quant information prevented the desired quant correlation

However, sufficient data on tetrazoles have been accumulated to allow research workers to make a few structure/property correlations. Bates and Jenkins (Ref 9a) have suggested that the ranking in expl behavior of twelve 5-substituted Nitrotetrazoles could be related to the substituent's electron withdrawing power: the more electron withdrawing, the more expl the compd. The ranking observed for the substituent in the 5 position ranged from mild ignitions for Methyl 5-Nitrotetrazole to instability in the following order: $\text{CH}_3 = \text{C}_6\text{H}_5$ (mild ignitions), $< \text{NH}_2$ $< \text{H} < \text{NHNO}_2$ (compds expld), $< \text{bis}$ (tetrazole) $< 5,5'$ -aziditetrazole (do not detonate RDX), $< \text{Cl} < \text{NO}_2$ (very powerful expls) $< \text{N}_3$ (very sensitive) $< -\text{N}_2^+$ (unstable)

The salts of 5-Nitrotetrazole could also be ranked according to their sensitiveness. The salts of Ag, Hg, and Pb gave more sensitive compns and greater initiating power than the alkali metal salts. The same salts of 5-Chlorotetrazole were too sensitive and corrosive, and those of 5-Azidotetrazole were too hazardous (Ref 9b)

Haskins (Ref 9c) has compared molecular orbital calcns of some azides and tetrazoles with expl behavior, dipole moments, and binding energies. He used an iterative extended Huckel molecular orbital approach to calculate dipole moments of 1-(H)tetrazole, 2-(H)tetrazole, and 5-aminotetrazole and found good agreement with exptl measurements. For example, 1-(H)tetrazole was calculated as 5.269μ and measured as 5.11μ . Binding energies calcd by the similar extended Huckel molecular orbital (EHMO)

method for the 1-(H) and 2-(H) compds were also in good agreement with exptl measurements

Haskins also compared the empirical ranking of expl behavior proposed by Jenkins with one devised according to total charge in the substituent group. Thus, EHMO results gave a quant measure of the electron withdrawing power of the substituents and gave an order: $\text{CH}_3 < \text{H} < \text{NH}_2 < \text{NHNO}_2 < \text{N}_3 < \text{NO}_2$. Haskins suggested that the EHMO calcns, although not in agreement with the qual ordering, were enough in agreement to indicate a relationship between expl behavior and electron withdrawal power from the ring

Schroeder et al (Refs 4–6; 8), as a corollary to the study of Tarver et al, have proceeded with a research program in quantum chemistry in an attempt to relate the ballistic and expl properties of compds such as the tetrazoles with their calcd and exptly derived molecular properties and to understand the chemistry of these compds. They reported (ca 1975) progress in their study in that the apparent greater electron withdrawing ability of the 1- rather than the 2- substituted 5-tetrazolyl groups is “. . . due to both resonance and electrostatic field effects . . .” (Ref 8, p 19)

Refs: 1) H. Rathsburg, BritP 185555 (1921) & CA 17, 1147 (1923) 2) F.R. Benson, “The Chemistry of the Tetrazoles”, ChemRevs 41, 1–61 (1947) & CA 41, 6885 (1947) 2a) S. Helf, I. Minsky & B.D. Guida, “Long Range Basic Research Leading to the Development of Superior Propellants”, PATR 1841 (1951) 2b) R.A. Henry & E.D. Besser, “Preparation and Preliminary Evaluation of 1-(5-Tetrazolyl)-2-Nitroguanidine and its Guanidinium Salt”, NAVORD 3483 (1955) 2c) D.B. Murphy et al, “High Nitrogen Compounds as Flash-Reducing Agents”, PATR 2029 (1954) 3) J. Cohen et al, “Evaluation of Substituted 5-Aminotetrazoles and Related Compounds in Double-Base Propellant Formulations”, NAVORD 5324 (1956) 3a) H. Morisson, “Chemistry of Tetrazole Explosives Derivatives”, IntSymp, Utilization of Pyrot & Expl Elements in Space Sys, Tarbes (Fr), Dunod (July, 1968) 4) M.A. Schroeder et al, “Quantum Mechanical Studies on Chemical Reactivity and Ballistic Chemistry. 1. CNDO/2 Calculations on Pyrrole and on its Aza Derivatives”, BRL 1557 (1971)

5) M.A. Schroeder et al, "Ibid. III. Effect of Assumed Molecular Geometry on CNDO/2 Electron Distribution for Some Tetrazole Derivatives", **BRL 1592** (1972) 6) M.A. Schroeder & R.C. Makino, "Ibid. IV. CNDO/2 Calculations on Azolium Cations and on the Zwitterions Resulting from their Deprotonation", **BRL 1618** (1972) 7) R. Shaw, "Structure-Property Correlations in Primary Explosives", **TPR 74-2**, Stanford Res Inst, Menlo Park, Contract N00017-73-C-4346 (1974) (AD A026746) 8) M.A. Schroeder, "Quantum Mechanical Studies on Chemical Reactivity and Ballistic Chemistry. VI. Literature Review on the Relationship Between Structure and Reactivity in Isomeric Tetrazole Derivatives", **BRL 1848** (1975) (AD A018652) 9) R. Shaw, "Structure/Property Correlations in Primary Explosives", **SRI-ITR 75-1**, Stanford Res Inst, Menlo Park, Contract N00024-75-C-5008 (1975) 9a) L.R. Bates & J.M. Jenkins, ProcIntnlConfResPrimaryExpls, (Vol 2, paper 12/14), ERDE, Waltham Abbey, Engl, (March 17-19, 1975) 9b) Ibid, paper 12/5 9c) P.J. Haskins, Ibid, paper 14/21 10) C.M. Tarver et al, "Structure/Property Correlations in Primary Explosives", **SRI-FR-76-2**, Stanford Res Inst, Menlo Park, Contract N00024-76-C-5329 (1976)

Tetrazole. This compd may be represented by two tautomeric formulas, the position of the hydrogen attached to one of the nitrogens being intermediate:

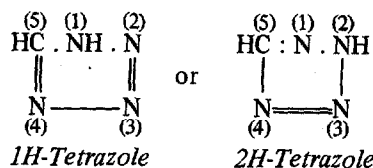

CH_2N_4 ; mw 70.05; N 79.84%; colorl prisms, ndles or lfits (from ethanol, tol or ethyl acetate). The compd's crystallographic properties are (Ref 26):
Crystal Morphology

Crystal System: Triclinic

Form and Habit: Plates flattened parallel to and usually lying on 001, showing the pinacoids, {001}, {010}, {100}, and occasionally the prisms, {110}

Axial Ratio: a:b:c = 0.915:1:0.687

Interfacial Angles (Polar): 001 Δ 100 = 86°; 001 Δ 010 = 57.7°; 100 Δ 010 = 106°

Crystal Angles: $\alpha = 130^\circ$; $\beta = 111^\circ$; $\gamma = 63^\circ$

X-ray Diffraction Data

Cell Dimensions: a = 5.00; b = 5.46; c = 3.75

Formula Weights per Cell: 1

Formula Weight: 70.06

Density: 1.406 (flotation); 1.632(X-ray) g/cc

Principal Lines

d, g/cc	I/I ₁	d, g/cc	I/I ₁
4.35	0.77	1.727	0.04
3.91	.032	1.703	0.10
3.38	0.60	1.676	0.02
3.20	1.00	1.649	0.03
2.68	0.10	1.603	0.09
2.62	0.06	1.572	0.03
2.48	0.10	1.553	0.04
2.33	0.06	1.536	Very weak
2.27	0.05	1.492	0.03
2.17	0.15	1.463	0.02
2.04	0.06	1.438	0.02
1.943	0.08	1.403	Very faint
1.870	0.04	1.364	Very faint
1.799	0.08	1.312	Very faint
1.773	0.06	1.195	Very faint
1.748	0.04	1.177	Very faint

Optical Properties

Refractive Indexes (5893 Å; 25°C)

$\alpha = 1.388 \pm 0.005$. $\beta = 1.595 \pm 0.002$.

$\gamma = 1.660 \pm 0.002$

Optic Axial Angles (5893 Å; 25°C).

$2V = 51^\circ$. $2E = 90^\circ$

Dispersion: $v > r$ very slight

Sign of Double Refraction: Negative

Acute Bisectrix: Almost \perp 001

Extinction: $\gamma \Delta a = 13^\circ$ on 001

Molecular Refraction (R) (5893 Å; 25°C).

$\sqrt[3]{\alpha\beta\gamma} = 1.54$. R (calcd) = 19.7 (imidine value for N's). R (obsd) = 15.6

Fusion Data: Tetrazole melts without decompn at 155.5° (equilibrium micro melting point) and crystallizes without supercooling to form flat rods with oblique extinction (ca 15°) and showing centered BX_a figures. Negative, $v > r$, $2E = 90^\circ$

It is easily sol in acet, acetic acid, hot eth acetate, w and ethanol; difficultly sol in benz and eth. CA Registry No's [27988-97-2] or [288-94-8]

Preparation. The first tetrazole was prepd in 1885 by the Swedish chemist J.A. Bladin. This was a derivative of tetrazole known as phenyl-

cyanotetrazole. In 1892, Bladin succeeded in prepg the parent compd by a series of degrading reactions, starting with phenyltetrazolecarboxylic acid. A simpler method for the prepn of tetrazole is by prolonged heating of a mixt of hydrazoic acid and anhydrous hydrocyanic acid;

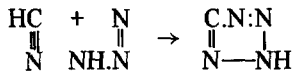

2-H-Tetrazole:

(Refs 2 thru 9). Other methods of prepn are given in Beil and other listed Refs. Benson (Ref 24, p 17) gives improved directions for the prepn of tetrazole as related to him in a private communication by Dr. R.M. Herbst of E. Bilhuber, Inc, Orange, N.J. In this procedure, 5.4g of anhydr hydrogen cyanide is heated in a sealed tube for 96 hrs at $110 \pm 5^\circ$ with 40cc of a 13.4% benz soln of hydrazoic acid. The benz soln is then decanted and the remaining crysts of tetrazole are dissolved in warm methanol. This soln is then mixed with the benz soln (mother liquor) and the solvents evapd on a w bath under reduced press. The residue is recrystd from 150cc of hot ethyl acetate. Yield is 75% of theory. The tetrazole ring structure is generally more stable than the pyrrole ring or other 5-membered heterocyclic ring compds. The N-atoms of its structure make tetrazole a strong acid. Tetrazole has a ΔH_c^v of 219.03 ± 0.21 kcal/mole and a ΔH_f^v of 56.66 kcal/mole at 25° (Refs 27 & 28)

Enumeration of the energetic matl uses of tetrazole per se include the following: Doin and Thomas claim in their patent (Ref 30) a proplnt contg tetrazole which is used for the inflation of automobile air bags by the generation of a non-toxic gas. Thus, tablets contg Na azide (70), K perchlorate (30), tetrazole (6.5) and Si dioxide (30 micron) (6.5p) produce 0.45ℓ/g of a gas contg N₂ (83), H₂ (16) and various non-toxic gases (1%) at a burning rate of 280mm/sec at 40 bar, producing 1000cal/g of heat on expln. Sayles (Ref 32) suggests a means of obtaining proplnt exhaust gases essentially free of w by using tetrazole in the form of a doughnut ring affixed forward of the rocket nozzle throat or as a toroidal ring at the aft end of the nozzle exit cone. Apparently, w vapor obscures IR sensor information required for guided missile performance. The inventor reports that the tetrazole, present to the extent of $\sim 70\text{g}/1-1.5$ moles of w calcd to be present in each 100g of

double-base propulsion gases, scavenges w from the exhaust gases while simultaneously generating N₂, H₂ and CO which also serve as valuable propulsion gases. Gawlick et al (Ref 33) claim in their patent the use of tetrazole in igniter systems for caseless ammo proplnts with a thermal decompn pt of $>180^\circ$. The tetrazole is incorporated into a booster compn which is then combined with std igniters. The booster charge is reported to contain hexanitrobiphenyl, hexanitrodiphenyl oxide and tetrazole as the basic ingredients

Because of its strongly acid nature, tetrazole reacts with bases to form expl salts such as:

5-Bromo-Tetrazole.

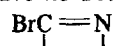

CHN₄Br; mw 148.96; N 36.62%; cryst powder from w, ndles from benz; mp 156° . V sol in hot ethanol and eth; moderately sol in w, exhibiting a strong acid reaction; and in benz. Prepn is by reacting a Cu salt soln with tetrazole diazonium bromide-(5). The green Cu salt of this compd detonates when heated quickly to 250° in the capillary tube of a mp appar. This salt is sol in dil hot mineral acids. According to Morisson (Ref 28a), it has an impact sensy of 1" (PA appar, 2kg wt), and 300mgs can initiate 400mgs of RDX to crush 69.7g of sand in the BuMines Sand Test

5-Chloro-Tetrazole.

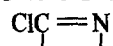

CHN₄Cl; mw 104.51; N 53.62%; mp 73° (decompn at 120°). V sol in eth, ethanol and w. Prepn is by reacting a soln of tetrazole diazonium chloride-(5) with a Cu salt. Its light blue Cu salt, Cu(CN₄Cl₂), explds violently at 300° on rapid heating. The salt is sol in hot dil mineral acids. According to Piechowicz (Ref 29), the Cu chlorotetraazolate is used in primers for space applications. According to Morisson (Ref 28a), it has an impact sensy of 1" (PA appar, 2kg wt) and 300mg can initiate 400mgs of RDX to crush 71.0g of sand in the BuMines Sand Test

The **Cu Salt** of 5-Tetrazole is considered to be a mild expl

5-Iodo-Tetrazole. CHN₄I; N 28.60%; de-comps, evolving flame at about 190°

The **Hg Salt**, a white ppt, puffs off mildly when heated to about 230° (Ref 18)

The **Ag Salt**; AgCHN₄; mw 176.93; N 31.67%; ndles; mp, explds violently on heating

Refs: 1) Beil **26**, 346, (108) & [196]
 2) Karrer (1950), 803 3) J.A. Bladin, Ber **18**, 1544 (1885) 4) Ibid, **25**, 1412 (1892)
 5) H. vonPechmann & E. Wedekind, Ber **28**, 1693 (1895) 6) K.A. Hofmann et al, Ber **43**, 1087 (1910) & CA, not found 7) Ibid **43**, 1866 (1910) & CA **4**, 2807 (1910) 8) Ibid **44**, 2946 (1911) & CA, not found 9) O. Dimroth & G. Fester, Ber **43**, 2223 (1910) & CA **4**, 2930 (1910) 10) H. Rathsburg, BritP 177744 (1922) & CA **16**, 3349 (1922)
 11) Ibid, BritP 185555 (1921) & CA **17**, 1147 (1923) 12) Ibid, BritP 201009 (1923) & CA **18**, 472 (1924) 13) Ibid, USP 1511771 (1924) & CA **19**, 178 (1925) 14) Ibid, USP 1580572 (1926) & CA **20**, 1907 (1926) 15) K.F. Schmidt, Ber **57**, 704 (1924) & CA **20**, 3460 (1926) 16) H.H. Strain, "Metallic Salts of . . . Tetrazole", JACS **49**, 1995 (1927) & CA **21**, 3054 (1927) 17) H. Rathsburg, ZAngewChem **41**, 1284-86 (1928) & CA **23**, 1271 (1929)
 18) R. Stollé et al, Ber **62**, 1118-26 (1929) & CA **24**, 2748 (1930) 19) Ibid, GerP 426346 (1929) & CA, not found 20) Anon, GerP 574943 (1933) & CA **27**, 4541 (1933) [Improved prepn of cyclic disubstituted tetrazoles]
 21) E. Franklin & F.M. Bergstrom, ChemRevs **16**, 305 (1935) & CA, not found 22) E. Lieber & G.B.L. Smith, ChemRevs **25**, 214-71 (1939) & CA **34**, 719 (1940) 23) V. von-Richter & R. Anschütz, "The Chemistry of the Carbon Compounds", Vol **4**, Elsevier, NY (1947), 69-74 24) F.R. Benson, ChemRevs **41**, 1-61 (1947) & CA **41**, 6885 (1947)
 25) R.M. Herbst et al, JOC **16**, 139-49 (1951) & CA **45**, 6629 (1951) 26) W.C. McCrone et al, "Tetrazole", AnalChem **23**, (4), 675 (1951) & CA **45**, 4520 (1951) 27) W.S. McEwan & M.W. Rigg, "The Heats of Combustion of Compounds Containing the Tetrazole Ring", JACS **73**, 4725-27 (1951) & CA **46**, 4350 (1952)
 28) F.R. Benson, "The Tetrazoles", in "Heterocyclic Compounds", Vol **8**, R.C. Elderfield, Ed, J. Wiley, NY (1967), 1-104 28a) H. Morison, "Chemistry of Tetrazole Explosive Derivatives", IntSymp Utilization of Pyrot & Expl Elements in Space Systs, Tarbes (Fr), Dunod (July 1968) 29) T. Piechowicz, "New Priming Explosives and Their Space Applications", Ibid (1969), 99-104 30) B. Doin & J.P.F. Thomas, GerP 2351401 (1974) & CA **81**, 108115 (1974)

31) W.F. Beckert & O.H. Dengel, USP 3940298 (1976) & CA **84**, 142945 (1976) 32) D.C. Sayles, USP 3942319 (1976) & CA **85**, 7957 (1976) 33) H. Gawlick et al, GerP 2543971 (1977) & CA **87**, 70417 (1977)

Derivatives and salts of tetrazoles. Tetrazole forms numerous derivatives which may be divided into the **C-type** (or 5-substituted compds), when the substituting radical is on the C atom, and the **N-type** when the substituting radical is on the N-atom, either in the 1- or 2-position. It has been observed that tetrazoles with a hydrogen in position 1 or 2 show the strength of organic acids

Many tetrazoles are low brisance expls, and those containing tetrazole rings linked to chains of nitrogen atoms, such as Tetrazole Azide (see below) or 1,6-Ditetrazolyhexadiene (Vol **7**, H91-L & R) are exceedingly sensitive to heat and impact. Probably **Diazotetrazole** (Vol **5**, D1176-L) represents the extreme in expl properties because it expls even in dilute aq solns (as low as 2%) and at temps as low as 0°. The expl derivatives of tetrazole are presented below:

1-Amino-Tetrazole and Derivatives

1-Amino Tetrazole. $\text{HC.N(NH}_2\text{).N}$
 $\begin{array}{c} \parallel \qquad \qquad \parallel \\ \text{N} \text{-----} \text{N, CH}_3\text{N}_7; \text{mw} \end{array}$
 113.17; N 86.66%. No prepn can be found for this compd. However, its expl derivatives are listed below:

1-Amino-5-Phenyl-1H-Tetrazole. See in Vol **1**, A247-L

1-(p-Aminophenyl)-1H-Tetrazole. See in Vol **1**, A247-R

1-Amino-1(1H-Tetrazol-5-yl) Azo Guanidine Hydrate (or Tetracene). See in this Vol under "Tetrazenes . . ." and in Vol **6**, G169-L to G172-R under "Guanylnitrosaminoguanyl Tetrazene . . ."

1-Amino-5-p-Tolyl-Tetrazole and Derivatives. See in Vol **1**, A265-R to A267-L under "Aminotolyl Tetrazoles and Derivatives"

1-Dichloroamino-5-o-Chlorophenyl Tetrazole.
 $(\text{Cl})_2\text{N.CN}_4(\text{C}_6\text{H}_4\text{Cl})$, $\text{C}_7\text{H}_4\text{N}_5\text{Cl}_3$; mw 264.51; N 26.48%. Prepn is by reacting 5g of 1-amino-5-o-Chlorophenyl Tetrazole, wetted with ethanol, with 600cc of aq hypochlorous acid soln, filtering off the product and washing it in ice-w. The dichloro product is so sensitive that it can be detonated by a touch from a spatula, impact, friction or by heating
 Refs: 1) Beil, not found 2) R. Stollé et al, JPrakt Chem **138**, (1-3), 10 (1933) & CA **27**, 4798 (1933)

1-Dichloroamino-5-Phenyl-Tetrazole.
 $(\text{Cl})_2\text{N.CN}_4(\text{C}_6\text{H}_5)$, $\text{C}_7\text{H}_5\text{N}_5\text{Cl}_2$; mw 230.07; N 30.45%. Prepn is by reacting 5g of finely powdered 1-amino-5-phenyl tetrazole, wetted with ethanol, with either chlorine gas or aq hypochlorous acid soln. The product is so sensitive to mechanical action that Stollé reports that it detonated when removed from filter paper with a spatula
 Refs: 1) Beil, not found 2) R. Stollé et al, JPraktChem **138** (1-3) 4 (1933) & CA **27**, 4798 (1933)

5-Amino-1H-Tetrazole (5-ATZ) and Derivatives.
 See in Vol 1, A258-L to A262-L and the following *Addnl Refs and Derivatives*:
 Refs: 1) F.R. Benson & R.W. Scharf, "Compounds of High Nitrogen Content in Propellant Powders", PATR **1538** (1945) [The authors conclude that inclusion of 25% 5-ATZ in cal .50 proplnt compns materially improve both

flash and smoke characteristics when compared to standard service powders of this era. The Q_g of the improved proplnt with 5-ATZ is reported as 751.95cal/g, while the gas vol of the combstn products is 910.5cc/g. However, the 5-ATZ contg proplnt gave a max vel of 100ft/sec less than the std compn (IMR-4814)] 2) S. Helf, "Long Range Research Leading to the Development of Ideal Propellants", PATR **1752** (1949) [The author reports the following (addnl) properties of 5-ATZ Nitrate (see Vol 1, A259-R): d 1.68g/cc; hygroscopicity at 30° & 90% RH is none; impact sensy is 8" using a 2kg wt in the PicArsn app; Sand Test (brisance) is 48.8g using a 0.1g Pb Azide initiator; sol in ethanol and w; sl sol in acet and eth; 100° heat test values of 0.55 wt % loss in 48 hrs and 0.17 in the second 48 hrs, with no expln in 100 hrs; 120° Vac Stab test is 11cc for a 1 g sample in 20 hrs] 3) W.S. McEwan & M.W. Rigg, "The Heats of Combustion of Compounds Containing the Tetrazole Ring", JACS **73**, 4725-27 (1951) & CA **46**, 4350 (1952) [The ΔH_c of 5-Nitroaminotetrazole is reported as 222.6Kcal/mole] 3a) W.F. Sager & D.V. Sickman, "Research and Development in New Chemical High Explosives", NAVORD **483** (1952) [Addnl properties of 5-ATZ Nitrate reported are a cryst d of 1.82 g/cc and an impact sensy approaching that of Pentolite] 3b) J.H. Bryden, "The Unit-Cell Dimensions and Space Groups of Some Tetrazole Compounds", ActaCryst **6**, 669-70 (1953) & CA **47**, 10947 (1953) [Table 1, below, delineates these properties:

Table 1
Unit Cell Dimensions and Space Groups of Some Amino-Tetrazole Compounds (Ref 3b)

Compound	a	b	c	β	Z	Space Group	d, g/cc	
							Obsd	Calcd
5-ATZ.H ₂ O	6.39	7.28	9.80	90°15'	4	P2 _{1/c}	1.51	1.504
5-ATZ.Guanidine	11.94	7.05	7.05	—	4	Pba	—	1.201
5-MeATZ	9.70	13.70	7.09	109°45'	8	C2/c or C _c	1.46	1.485
5-Nitro-ATZ	9.40	5.56	9.36	105°0'	4	P2 _{2/c}	1.82	1.832
5-DiMeATZ	13.78	9.90	7.88	—	8	Pbca	—	1.398
1-Me-5MeATZ	14.24	10.01	7.77	—	8	Pbca	—	1.357

3c) F. Taylor, "Primary Explosive Research", **NAVORD 2800** (1953) [A number of metallic salts of 5-NATZ (see Vol 1, A260-L) were prepared in order to determine their suitability as primary expls. However, it was found that only the *silver*, *cupric* and *mercurous* compds are insol in w. The expl properties of these compds were explored to the extent of impact sensy, hot bar ign temp and vac stab. This information is presented below in Table 2:

Table 2
Impact Sensitivity, Hot Bar Ignition Temperature and Vacuum Stability (Ref 3c)

5-ATZ Compd	Impact Sensy, cm (2.5kg wt)	Hot Bar Ign Temp, °C	Vac Stab, ml/gas/48hrs/100°
Mercurous Salt	38	256 (deton)	2.05
Cupric Salt	68	256	0.29
Silver Salt	22	366	0.24]

Table 3
Nomenclature, Formulas, Melting Points and Heats of Explosion of 5-Amino Tetrazole Derivatives Used as Experimental Propellant Additives (Ref 4)

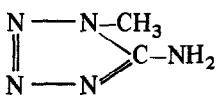
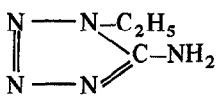
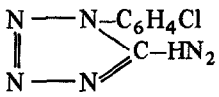
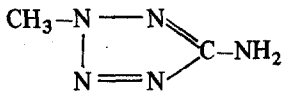
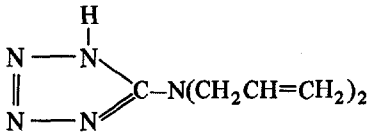
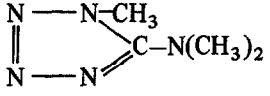
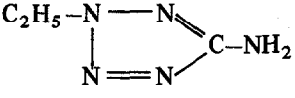
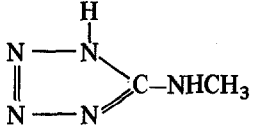
Name	Formula	Melting Point, °C	$-\Delta H_e$ (avg), ^a Kcal/mole
1-Methyl-5-aminotetrazole		228	405.16 ± .11
1-Ethyl-5-aminotetrazole		147-148	—
1-(m-Chlorophenyl)-5-aminotetrazole		174-175	—
2-Methyl-5-aminotetrazole		104.5-105.5	409.30 ± .49
5-Diallylaminotetrazole		96-97	1118.03 ± .54
1-Methyl-5-dimethylaminotetrazole ^b		43-44	—
2-Ethyl-5-Aminotetrazole		mp ca 20 bp 94 at 1mm	—
5-Methylaminotetrazole		185-187	407.31 ± .47

(continued)

Table 3 (continued)

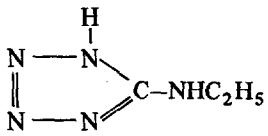
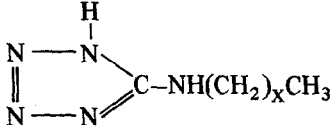
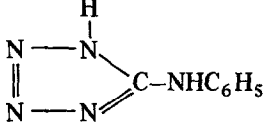
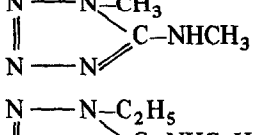
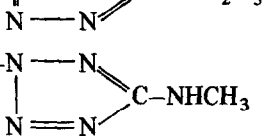
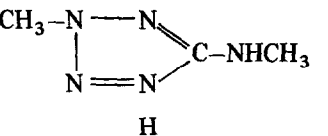
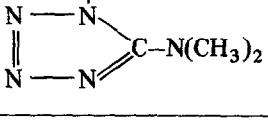
Name	Formula	Melting Point, °C	$-\Delta H_c$ (avg), ^a Kcal/mole
5-Ethylaminotetrazole		174-175	—
5-n-heptyl, 5-n-octyl, and 5-n-decylaminotetrazole		x=6 164-165 x=7 164-165 x=9 163-164	—
5-Phenylaminotetrazole		211-212	970.31 ± .02
1-Methyl-5-Methylaminotetrazole ^b		172-173	569.09 ± .70
1-Ethyl-5-ethylaminotetrazole		96-97	—
2-Methyl-5-methylaminotetrazole		48-49	—
5-Dimethylaminotetrazole		244-246 235-236	564.95 ± .54

Footnotes to Table 3:

a—from M.M. Williams et al, "The Heats of Combustion of Substituted . . . Tetrazoles . . .", *JPhysChem* **61**, 261-67 (1957) & *CA* **51**, 9284 (1957)

b—Prepn, S. Helf et al, *PATR* **2029** (1954), p 16 & 17

4) J. Cohen et al, "Evaluation of Substituted 5-Aminotetrazoles and Related Compounds in Double-Base Propellant Formulations", *NAVORD* **5324** (1956) [The measured heat of expln is reported for two proplnt compns contg NC (12.6% N) 41.04 and 40.0; NG 35.75 and 26.3; diethylphthalate 11.16 and 7.7; 2-NDPA none and 1.0; and 5-ATZ 12.05 and 25.0%; as 837.5 and 761Kcal/g, respectively. Other 5-ATZ derivatives of interest as proplnt additives described in this ref are shown in Tables 3 and 4

Table 4
Heat Stability Tests at 136° on Double-Base Propellant Formulations
Containing Various Tetrazoles and No Other Stabilizer (Ref 4)

Compn: 37% Nitrocellulose (12.6% N), 30% Nitroglycerin, and 33% Tetrazole Derivative

Compound	First Salmon Color on Methyl Violet Paper, Minutes	Definite Salmon Color, Minutes	Decomposition, Minutes
5-Methylaminotetrazole	25	—	39–42
5-Dimethylaminotetrazole	3	8	8–16
5-Diallylaminotetrazole	—	—	8–10
5-Ethylaminotetrazole	16	26	32
5-Heptylaminotetrazole	32	—	33
5-Phenylaminotetrazole	7	11	135
1-Methyl-5-aminotetrazole	5	—	10–13
1-Ethyl-5-aminotetrazole	—	—	9
1-(m-Chlorophenyl)-5-aminotetrazole	28	—	150–180
2-Methyl-5-aminotetrazole	25	—	28–29
2-Ethyl-5-aminotetrazole	21	—	29–39
1-Methyl-5-methylaminotetrazole	30	60	Melted but no expln
1-Ethyl-5-ethylaminotetrazole	30	45	Melted but no expln
1-Allyl-5-allylaminotetrazole	—	—	(a)
2-Methyl-5-methylaminotetrazole	117	210	Melted but no expln
1-Methyl-5-dimethylaminotetrazole	(b)	25	—

Footnotes to Table 4:

a—Melted after 10 mins, frothed after 55 mins

b—Melted after 7 mins, frothed after 20 mins

4a) M. Tremblay, "Synthesis of Some Tetrazole Salts", CanJChem **43**, 1230–32 (1965) & CA **63**, 599 (1965) [The following expl 5-NATZ salts and their properties are reported:

Aminoguanidinium-5-Nitroaminotetrazole (GNAT).

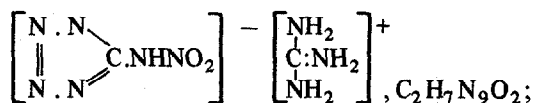

mw 189.18; N 66.65%; OB to CO₂ —46.5%; white cryst; mp 214–15°. Sol in warm w; insol in ethanol. Prepn is by reacting an aq ethanolic soln of aminoguanidine bicarbonate with nitroguanylazide. The product is recrystd from w. The salt has a ΔH_c of 26.59kcal/mole, and an impact sensy of 30cm at the 50% pt using a Bruceton app with a 2kg wt

According to Cohen et al (Ref 4, above) the salt has been used as a ballistic modifier to replace NGu in Cordite-N and mesa burning type naval proplnts such as X-5, X-6, X-7 and X-8. It substantially increases the burning rate

5-Aminotetrazolyli-5'-Nitroamino Tetrazole.

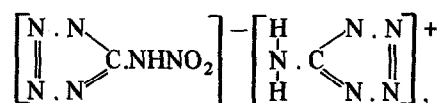

C₂H₃N₁₁O₂; mw 213.16; N 72.30%; OB to CO₂ 11.26%; cryst; mp 178° (decompn). Sol in warm w. Prepn is by reacting an aq soln of 5-ATZ Nitrate with an aq soln of 5-NATZ (see Vol 1, A260-L). The product is recrystd from w. The yield is 70%. The 50% pt impact sensy lies between 8–30cm using a Bruceton app with a 2kg wt

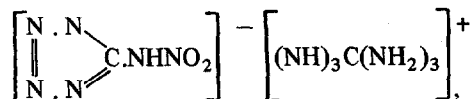
Triaminoguanidinium-5-Nitroaminotetrazole.

$\text{C}_2\text{H}_{10}\text{N}_{12}\text{O}_2$; mw 234.24; N 71.8%; OB to CO_2 -47.81%; white solid; mp 184–86°. Prepn is by heating an aq mixt of 5-NATZ with TAGN. The product crystallizes out on cooling. The salt has a 50% pt impact sensy of 8cm using a 2kg wt in a Bruceton app] 5) D.T. Elmore, "Diazotization Hazard", ChemBrit 2, 414 (1966) [The author points out that 5-ATZ forms an expl complex on being diazotized. For example, he reports that while being stirred magnetically an entire diazotization appar was demolished by an expln. To avert this danger he recommends adjustment of the pH of the diazotizing mixt to 5 by addn of K hydroxide] 5a) H. Morisson, "Chemistry of Tetrazole Explosives Derivatives", IntSymp on UtilPyrots&Expls in Space Systs, Tarbes (Fr), Dunod (1968), 11 [The expln temps of the following ATZ's are reported:

Compd	Expln Temp, °C
Lead Diazoaminotetrazole	285
Copper Nitroaminotetrazole	256
Mercury Nitroaminotetrazole	256
Silver Nitroaminotetrazole	366;

also reported are the impact sensy of Lead Diazoaminotetrazole as 280mm and Copper Diazoaminotetrazole as 220mm using the A.T.S. appar (Fr) with a 2kg wt] 6) H. Gawlick et al, "Propellant Composition Containing an Organic Tetrazole Derivative and Metal Oxidizer", USP 3468730 (1969) & CA 72, 14384 (1970) [The inventors claim a proplnt compn contg 5-ATZ effective for switching elements, triggering switching elements and/or controlling processes. It is resistant to shock, produces non-corrosive gases, and is controllable as to its rate of reaction. Thus, mixts of 10–50% 5-ATZ and 50–90% K nitrate upon ign provide performance in accordance with the patent claims] 6a) L.R. Bates & J.M. Jenkins, "The Salts of 5-Substituted Tetrazole . . . Some Metallic Salts . . . of . . . 5-Aminotetrazole . . .", ERDE-TN-25, Waltham Abbey, Essex, Engl (1970) [Table 5 presents methods of prepn of the salts by either 1) treatment of the hydrated metal nitrate salts with solns of the tetrazoles as free acids, or 2) treatment of the hydrated metal nitrate salts

with solns of the Na salts of the tetrazoles. Some salt properties are also given:

Table 5
Preparation of 5-ATZ Salts (Ref 6a)

Compd	Method of		
	Prepn	Color	Comment
AgATZ	2	Colorl	Microcrystn ppt
Co(ATZ) ₂ ·XH ₂ O	1	Pink	Pptd from acet
Cu(ATZ) ₂ ·H ₂ O	1	Green	Pptd from acet
Ni(ATZ) ₂ ·H ₂ O	1	Blue	Pptd from acet
Pb(ATZ) ₂	2	Colorl	Pptd with acet from w

Table 6 presents the reported ign data of some 5-ATZ salts

Table 6
Ignition Properties of
Some 5-ATZ Metal Salts (Ref 6a)

Compn	Ign		Effect as a Constituent of an Ign or Delay Train
	Temp, °C	Ign Type	
Ag(ATZ)	352	Smoke	Ignites but fails to support train
Co(ATZ) ₂ ·XH ₂ O	228	Exploded	ditto
Cu(ATZ) ₂ ·H ₂ O	164	Flame	ditto
Ni(ATZ) ₂ ·H ₂ O	290	Exploded	ditto
Pb(ATZ) ₂	303	Flame	ditto

The authors conclude that the 5-ATZ salts ". . . have little technical promise due to their instability, variability in composition and poor physical form . . ." 7) B.K. May et al, "Gas-Generating Solid Propellant Containing 5-Aminotetrazole Nitrate", USP 3734789 (1973) & CA 79, 8021 (1973) [The inventors claim a compression molded proplnt compn of d 0.056 lbs/in² with a strand burning rate of 0.57 in/sec at 77°F and 1000psi, incorporating 5-ATZ Nitrate (85), polyisoprene rubber (12.75), Conco oil (2.25) and p-quinonedioxime (0.06 wt %)] 8) R.A.H. Strecker & H.S. Haiss, "Solid 5-Aminotetrazole Nitrate Gas Generating Propellant with Block Copolymer Binder", USP 3898112 (1975) & CA 84, 7207 (1976) [The inventors claim compression or extrusion molded proplnt grains requiring no curing contg 5-ATZ Nitrate with a

burning rate of 0.420 in/sec at 1000psi and 77°F and an ign temp of 168°. Thus, a benz soln of a rubbery styrene-butadiene block copolymer of mw 60000–100000 contg 28–9% styrene (13) is mixed with 5-ATZ Nitrate (84), 2,2'-methylene bis (4-methyl-6-tert-butylphenol) (0.25) and Conco oil (2.75%) under vac until no solvent remains. The dry mixt is then processed into proplnt grains]

9) M.S. Chang et al, "Solid Gas Generating and Gun Propellant Composition Containing Triamino-guanidine Nitrate and Synthetic Polymer Binder", USP 3954528 (1976) & CA 85, 162927 (1976) [Claimed is a solid composite gas generating and proplnt compn which is cool burning with a flame temp of 2208°K at 300psi and approx 2358°K at 1000psi; thermally stable; no wt loss in one month at 140°F; with a theoretical gas availability of 5.155 moles. Thus, a mixt of 5-ATZN (75), TAGN (13), OH-terminated polybutadiene of mw 2600 (11.2) and toluene diisocyanate (0.8 (added) %) forms the patented proplnt]

10) F.J. Einberg, "Adhesive Tetrazole Polymers", USP 4013596 (1977) & CA 86, 156216 (1977) [Polymers contg 5-ATZ claimed to be useful as binders in proplnt systems were prepd by condensing 5-ATZ in DMF with chloroacetyl chloride to give N-(5-tetrazolyl) chloroacetamide which is polymerized by treatment with methanolic K hydroxide]

Derivatives:

5-Aminoethyltetrazoles and Derivatives. See in Vol 1, A206-R to A207-R

Aminophenyltetrazoles and Derivatives. See in Vol 1, A246-R to A249-L

Aminotolyltetrazoles and Derivatives. See in Vol 1, A265-R to A267-L

Bistriethyl-Lead Azoaminotetrazole. See in Vol 2, B158-R under "1,3-Bis (1H-Tetrazolyl-5)-Triazine, Ditrethyl Lead Salt" and in Vol 5, D1521-L under "Di-Triethyl Lead Azoaminotetrazole"

Diazotetrazole-Aminoguanidine. See in Vol 5, D1176-L & R

5,5'-Diazoaminotetrazole and Derivatives (or Diazoaminotetrazotic acid). See in Vol 2, B158-L & R under "Bis(Tetrazolyl)-Triazine and Derivatives" and the following *Addl Ref*: K. Bahadur, "Study of Some Double Salts of Lead Useful as Initiating Explosives by Thermo-gravimetry and Thermometric Titrations", Symp-ChemProblConnectedStabExpls[Proc], 3rd 1973 (Pub 1974), J. Hansson, Ed, & CA 83, 30455 (1975) [The author reports that **Lead-5,5'-Diazoaminotetrazolate Styphnate** was found to be superior as an initiator expl to other double complexes with azotetrazolic acid or 5-nitraminotetrazolic acid investigated, and it is recommended as an "ideal" replacement for Pb Azide

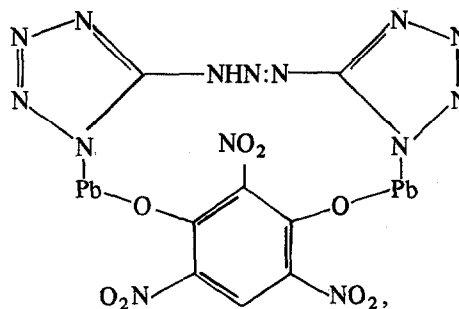

$C_8H_2N_{14}O_8Pb_2$; mw 636.64; cryst; N 30.18%; OB to CO_2 -248.81%. CA Registry No [55512-53-3] Prepn is by reacting a 0.1M aq Pb St soln with an aq soln of Na-5,5'-diazoaminotetrazole

5-Dimethylamino- α -Tetrazole. See in Vol 5, D1312-R

1,4-Dimethyl-5-Iminotetrazole.

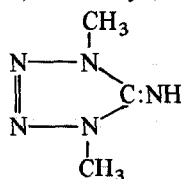

$C_3H_7N_5$; mw 113.15; N 62.0%; white cryst; mp 106.4–107.4°; bp 122° at 32mm. Prepn is by reacting 1-methyl-5-aminotetrazole with dimethyl sulfate. Yield is 69%

Murphy et al (Ref) indicate that this compd is an excellent high energy proplnt additive for the purpose of smoke and flash attenuation
Ref: D.B. Murphy et al, "High Nitrogen Compounds as Flash-Reducing Agents", PATR 2029 (1954)

1,4-Dimethyl-5-Methylaminotetrazole Hydrochloride.

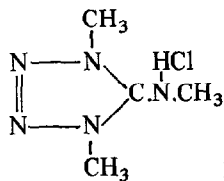

; $C_4H_{10}N_5Cl$; mw 163.64; N 42.81%; deliq cryst; mp 202–03°. Sol in hot isopropanol. Prepn is by reacting 1,4-dimethyl-5-aminotetrazole with dimethyl sulfate. The oily product is crystd as the hydrochloride

Murphy et al (Ref) indicate that this compd is an excellent high energy proplnt additive for the purpose of smoke and flash attenuation

Ref: D.B. Murphy et al, "High Nitrogen Compounds as Flash-Reducing Agents", PATR 2029 (1954)

Disilver Aminotetrazole Perchlorate (or 1,3-Disilver-5-aminotetrazole perchlorate).

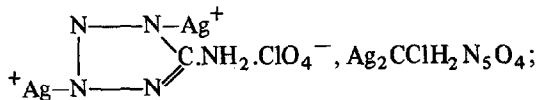

mw 291.40; N 24.04%. Prepn is by treating 6g of Ag perchlorate in 32cc w with 5.2g 5-ATZ in 184cc of 70% perchloric acid. The salt is stable at 500°±50°F. Rittenhouse's patent suggests use as a primary expl for initiation of TNT or DIPAM

Refs: 1) Beil, not found 1) C.T. Rittenhouse, USP 3663553 (1972) & CA 78, 60375 (1973)

Guanidinium-5-Nitroaminotetrazole. See in this article under "5-Amino-1H-Tetrazole (5-ATZ) and Derivatives" as "Aminoguanidinium-5-Nitroaminotetrazole (GNAT)", and the following Addnl Ref: 1) LeMoyné Plischke & R.A. Henry, "An Alternative Method for the Preparation of Guanidinium-5-Nitroaminotetrazole (GNAT)", NOTS-TM-1580 (1953) [Addnl energetic properties of GNAT are shown in Table 6A

Table 6A
Energetic Properties of GNAT

Test	Results
Wt Loss at 100°C	
after 2 days	0.16%
after 7 days	0.18%
Thermal Stability Test	No change on methyl violet paper after 8 hours
At 135°C	
Temperature of Explosion	
154°C	No fire
194°C	No fire
259°C	2.5 sec (average)
282°C	0.6 sec (average)
Impact Sensitivity—	
2kg hammer—50% pt	
Garnet paper	14cm (a) low order
Carborundum paper	22cm (b) low order
Vacuum Stability	0.33ml/gram
48 hours at 120°C	

Footnotes to Table 6A:

- (a) RDX (1–5μ), 12.5cm; RDX (Holston), 21cm; TNT, 44.5cm
 (b) RDX (1–5μ), 22.5cm; TNT, 140cm; PETN, 12cm]

Guanidinium-Nitroguanaminotetrazole(Guanidinium-1-(5-tetrazoly)-2-Nitroguanidine).

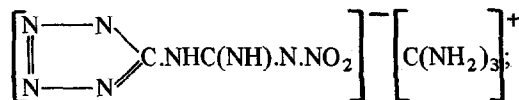

$C_3H_9N_{11}O_2$; mw 231.23; N 66.65%; OB to CO_2 –58.82%; white, fluffy rosettes; mp 236–40° (decompn). Sol in hot 60% ethanol and hot w. Prepn is by first reacting a cold aq soln of anhydr 5-aminotetrazole with guanidinium carbonate, releasing carbon dioxide. When the reactants are completely dissolved, 95% ethanol and 1-methyl-1-nitroso-2-nitroguanidine are added to the reactant soln. It is then allowed to stand at RT for 1 week. The resulting granular product is then put into soln by heating the mixt. Re-pptn occurs on cooling overnight at 5°. The product yield is 33.1%. Product recrystn is from either w or 60% ethanol

The salt has a 50% pt impact sensy of >190cm (TNT=140cm) (2kg wt sample on Garnet paper); thermal stab at 135° for 8 hrs reveals no change

in the methyl violet test paper with no deflagration of the sample; and a vac stab at 100° for 48 hrs of 0 ml/g of gas

Henry and Besser (Ref) report that the salt is less effective as a proplnt burning rate booster than the parent acid, although it still yields faster burning proplnts than similar formulations using Nitroguanidine. The cool proplnt formulation used as an evaluation vehicle consisted of NC (29.84), NG (7.86), 1-ethyl-5-ethylamino-tetrazole (7.50), and the subject salt (54.80%)
 Ref: R.A. Henry & E.D. Besser, "Preparation and Preliminary Evaluation of 1-(5-Tetrazolyl)-2-Nitroguanidine and its Guanidinium Salt", NAVORD 3483 (1955)

Guanylamino-tetrazole. See in Vol 6, G166-L under "α-Tetrazol-5-yl-guanidine" and the following *Addnl Ref*: S. Helf, I. Minsky & B.D. Guida, "Long Range Basic Research Leading to the Development of Superior Propellants . . .", PATR 1841 (1951) [The authors conclude that ". . . both guanylamino-tetrazole and its nitric acid salt are worthy of further consideration and investigation as cool, high potential propellant ingredients . . ."]

Guanylamino-tetrazole Nitrate. See in Vol 6, G166-R under "α-Tetrazol-5-yl-Guanidine Nitrate" and the following *Addnl Refs*: S. Helf et al, "Long Range Basic Research Leading to the Development of Superior Propellants", PATR 1841 (1951) [The authors report the following properties of interest: d 1.58g/cc; nil hygry at 30° & 90% RH; impact sensy of 10" using a 2kg wt in a PicArnsn app; expln temp of 180°; sl sol in w; 100° heat test result of a wt loss of 4.75% in the first 48 hrs, and nil during the second 48 hrs; and a 90° vac stab test result of 0.35cc of gas in 40 hrs from a 1 g sample]

1-Methyl-5-Nitramino-tetrazole.

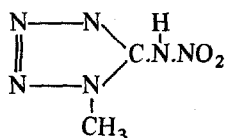

$C_2H_4N_6O_2$; mw 144.12; N 58.33%; OB to CO_2 -44.41%; cryst; mp 127°

(decompn). Sol in hot eth. Prepn is by reacting 1-methyl-5-aminotetrazole nitrate with concd sulfuric acid

Murphy et al (Ref) indicate that this compd is an excellent high energy proplnt additive for the purpose of smoke and flash attenuation

Ref: D.B. Murphy et al, "High Nitrogen Compounds as Flash-Reducing Agents", PATR 2029 (1954)

Nitroguanylamino-tetrazole. [1-(5-Tetrazolyl)-2-nitroguanidine].

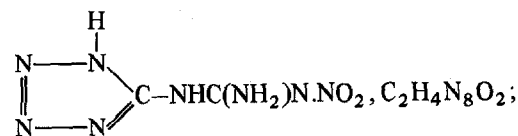

mw 172.14; N 65.11%; OB to CO_2 -37.18%; fine, white granular powder; mp decomn at 247°. Sol in hot w. Prepn is as follows: Guanylamino-tetrazole nitrate (7.0g) is slurried in 40ml of trifluoroacetic acid and cooled to -20°. Trifluoroacetic anhydride (11 ml) is then added, and the temp is allowed to rise to about -10°. The temp is then maintained between -3 and -10° for 30 mins. The nitrate will gradually dissolve, some gas being evolved, and the soln assumes a pale yel color. The nitration mixt is then poured into 200ml of cold diethyl ether; a white, somewhat gelatinous solid being pptd. The product is removed by filtration, washed with more cold ether until free of trifluoroacetic acid, and dried. The yield is 2.7g (42.6%). Two recrystns from w which contains a few drops of concd HCl have been found to give a product with an equiv wt of ca 189.9 (theory 190.13 for a monohydrate)

The tetrazole has an impact sensy at the 50% pt of 42.5cm (TNT=140cm) (using a 2kg wt, sample on Garnet paper); a thermal stability at 135° of no change in the methyl violet paper after eight hrs, nor deflagration of the sample; and a vac stab of 0.83ml/g of gas at 100° for 47 hrs

Henry and Besser report that the inclusion of the tetrazole (54.80) with NC (29.84), NG (7.86) and 1-ethyl-5-ethylamino tetrazole (7.50%), produces a two-to-threefold increase in the burning rate of this cool proplnt compn over that shown by comparable formulations containing Nitroguanidine

Ref: R.A. Henry & E.D. Besser, "Preparation and Preliminary Evaluation of 1-(5-Tetrazolyl)-2-Nitroguanidine and its Guanidinium Salt", **NAVORD 3483** (1955)

1-Methyl-5-Nitrosamino-Tetrazole.

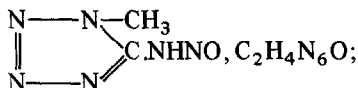

mw 128.12; N 65.61%; OB to CO_2 -62.44%; leaflets; mp, explds mildly at 177° . Sol in alkalis, hot ethanol and hot w; sl sol in ethanol and w; insol in eth. Prepn is by treating a 2N HCl soln of 1-methyl-5-amino tetrazole with a concd aq soln of Na nitrite

Refs: 1) Beil, not found 2) J. Thiele & H. Ingle, *Ann* **287**, 252 (1895) 3) R. Stolle, *JPraktChem* **134**, 283, 286-87 (1932) & *CA* **26**, 5565 (1933)

Monotriethyl-Lead Azoaminotetrazole. See in Vol 2, B158-R under "1,3-Bis (1H-Tetrazolyl-5)-Triazine, Monotriethyl Lead Salt"

5-Nitrosamino-1-Phenyl- α -Tetrazole and Salts. See in Vol 1, A248-L

5-Picrylaminetetrazole. See in Vol 8, P247-R

N-(2,2,2-Trinitroethyl) Aminotetrazole.

$(\text{NO}_2)_3\text{C.C.N.CN}_4\text{H}$, $\text{C}_3\text{HN}_8\text{O}_6$; mw 245.12, N 45.72%; OB to CO_2 -13%; mp 147° . Prepn is by reacting 5-methylolaminotetrazole with nitroform in methanol soln at 65° for several hrs, then cooling, followed by filtrn, washing and then drying the product. The expl has a KI-starch stability of 10 mins at 82.2°

Refs: 1) Beil, not found 2) R.H. Saunders, *USP* 2998424 (1952) & *CA* **56**, 623 (1962)

The Azido Tetrazoles and Derivatives

5-Azido Tetrazole (Tetrazolyl azide, 5-Triazo-tetrazole, Diazotetrazolimide, Tetrazylazoimide or [Tetrazolyl-(5)]-azoimid (Ger)).

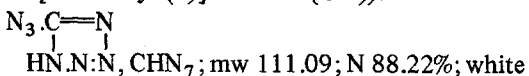

ndles (from benz, chl_f or C tetrachloride); mp $72-74^\circ$; bp, explds ca 217° . V sol in acet, ethanol, eth and w; sl sol in benz, chl_f and C tetrachloride; insol in ligr. Prepn is from cyanogen bromide and Na azide in w. The azide is fairly stable in storage when in the pure state, but it may expld spontaneously in the presence of some impurities. Particularly dangerous is acetic acid, traces of which might cause the deton of the azide even if it is dissolved in acet. However, this does not occur in aq or alcoholic solns. The azide explds violently on heating, friction or impact. In the v pure state it is less sensitive to impact than its (alkaline) salts which are presented next:

Ammonium Salt, NH_4CN_7 ; mw 128.13; N 87.47%; white powdr; mp, puffs off on heating. V sol in methanol and w, sl sol in benz and ethanol

Barium Salt. $\text{Ba}(\text{CN}_7)_2$; mw 384.74; N 25.51%; v deliq cryst; mp, deflagrates v violently with a red flame on heating. Sol in acet, eth and pyr; insol in anhydr eth, abs ethanol, C disulfide, C tetrachloride, trichloroethylene, benz, chl_f and petr eth. The salt's impact sensy at the 50% pt using a 500g wt is 35cm

Lead Salt. $\text{Pb}(\text{CN}_7)_2$; mw 427.36; N 45.68%; cryst; mp, explds with a red flame on heating. Insol in eth, abs ethanol, C disulfide, C tetrachloride, trichloroethylene, benz, pyr, acet, chl_f, petr eth and w. The lead salt detons when touched with a flame and has an impact sensy of over 100cm using a 5kg wt. Rathsburg (Refs 5 & 6) suggested that 0.15g of the salt be incorporated with 1.0g of Tetryl and 0.15g of Lead Azotetrazole to form a blasting cap compn

Mercury Salt. $\text{Hg}(\text{CN}_7)_2$; mw 420.75; N 46.62%; white solid. Not sol in w. Termed an expl

Potassium Salt. KCN_7 ; mw 149.18; N 65.74%; shiny white plates or ndles; mp $72-73^\circ$ (explds without melting). V sol in acet, ethanol and w; not sol in benz, eth and C tetrachloride. Prepn is from tetrazolyl azide and K acetate. The salt explds violently when placed on a surface previously heated to 60° or above, or when heated in a flame, giving a purple color. It is extremely sensitive to mechanical action and can be detonated by touching it with a spatula. The K salt is so brisant that even amounts as small as 0.01g can cause damage

Silver Salt. AgCN_7 ; mw 217.95; N 45%. Insol

in cold dil nitric acid and w. It is extremely sensitive, explg even in a moist condition
Sodium Salt. NaCN_7 ; mw 133.07; N 73.70%; shiny white plates; mp (explds). Prepn is from Na nitrite and Na acetate. Its properties are similar to the K azide salt

It is to be noted that Rathsburg (Refs 5 & 6) patented the use of Azidotetrazole and its derivatives in detonators and percussion caps after desensitizing these compds by coating with paraffin, resin or other techniques described in the patents (see above in the introduction to this article)

Organic Derivatives of Azidotetrazole

Friederich (Refs 7 & 8) patented the prepn and use of expls prepd by action of alkali salts of tetrazylazide on organic chlorides or sulfates. Examples of these expl compds are given below:

1) Alkyltetrazylazides

Ethylenetetrazylazide. $\text{C}_3\text{H}_3\text{N}_7$; mw 137.10; N 71.53%; oily liq. It possesses extraordinary brisance and is easily ignited by sparks and flames. The azide gelatinizes NC and forms easily ignitable gelatines which have high shattering power. When absorbed in porous materials such as kieselguhr or cellulose paper, it becomes an excellent igniter for proplnts

Ethyltetrazylazide. See Vol 6, E331-R

2) Hydroxytetrazylazides

1-Hydroxy-5-Azido-Tetrazole (or 1-Oxy-5-azido-tetrazol (Ger).

$\text{N}_3\text{C}(\text{N}=\text{N})\text{N}(\text{OH})$, CHN_7O ; mw 127.09; N 77.11%; OB to CO_2 -18.88%; cryst; mp 65° . Prepn is by acidifying its Na salt. The Na salt is prepd by treating Na azide with a mixt of nitrobrompicrin and ethanol. The compd is an expl less powerful but more sensitive to impact than Tetryl. It forms expl salts which are extremely sensitive to impact or friction with metals such as *mercury* or *silver*

3) Aryltetrazylazides

[1-Phenyl, 5-Azido]-Tetrazole. See in Vol 8, P246-R

4) Ketone-Tetrazylazides

Acetoniltetrazoles and Derivatives. See Vol 1, A46-R to A47-L

5) Urea-Carbamyl Azido Tetrazoles

N-(5-Tetrazolyl) Carbamyl Azide.

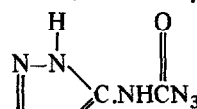

$\text{C}_2\text{H}_2\text{N}_8\text{O}$; mw 154.12; N 72.72%; OB to CO_2 -41.53%; white ndles; mp 207° (decompn). V sol in concd HCl and aq solns of alkalies (with decompn); v sl sol in dil HCl; v difficultly sol in w. Prepn is by adding slowly, with stirring, an aq soln of Na nitrite to a soln of 4-(5-tetrazolyl)-semicarbazide in concd HCl at 0° . The yield is 61%. The compd burns vigorously when ignited and is more sensitive to impact than Pb Azide

According to Friederich's patents the organic tetrazylazides are more stable and less sensitive than the salts. He suggested that they be used, either alone or in various mixts, as ignition compns for percussion caps, detonators, electric primers, detonating fuses, etc. Suitable secondary charges are PETN, RDX, Tetryl or TNT
 Refs: 1) Beil **26**, 347, (110) & [197]

2) J. Thiele & H. Ingle, Ann **287**, 238 (1895)
 3) K.A. Hofmann et al, Ber **43**, 1091-93 (1910) & CA, not found 4) Ibid, **44**, 2947 (1911) & CA, not found 5) H. Rathsburg, BritP 185555 (1922) & CA **17**, 1147 (1923)
 6) Ibid, USP 1511771 (1924) & CA **19**, 178 (1925) 7) W. Friederich, USP 2170943 (1939) & CA **34**, 265 (1940) 8) W. Friederich & K. Flick, USP 2179783 (1939) & CA **34**, 1827 (1940) 9) F.R. Benson, ChemRevs **41**, 8 (1941) & CA **41**, 6885 (1947) 10) Blatt, OSRD **2014** (1944) 11) E. Lieber & D.R. Levering, JACS **73**, 1313-17 (1951) & CA **45**, 9486 (1951) 11a) L.F. Audrieth & J.W. Currier, "Compounds of High Nitrogen Content - Derivatives of 5-Aminotetrazole", Final Rept-Part B, Univ of Ill, Urbana, Contract DA-11-022-ORD-33 (1954), 45-47 12) H. Ficherouille & A. Kovache, MP **41**, 9-11 (1959) & CA, not found 13) A.J. Baratt et al, "Some Reactions of the Azotetrazole Anion with Dilute Mineral Acids", ERDE-TN-44 (1971) & CA **78**, 124508 (1973)

The Azotetrazoles

Sometimes called diazotetrazoles. Here, usually only 5-azotetrazole, its salts and derivatives are of ordn interest as primary or initiator expls. Two different molecular structures exist which are identified by this nomenclature:

I) Compds of the monotetrazole azo radical

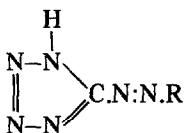

where R is any substituent comprising the remainder of the salt or derivative molecule, while the H in the 1-position may also be replaced, and II) Compds based on the bis-tetrazole-azo structure

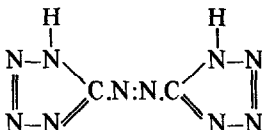

I) *Monotetrazole-Azo Compds*

5-Azotetrazole. See in Vol 5, D1176-L and in Beil 26, (190) & [350]

p-Aminobenzene, Tetrazolyl-5-Azo.

$(\text{H}_2\text{N})\text{C}_6\text{H}_4.\text{N}:\text{N}:\text{C}:\text{N}:\text{N}:\text{H}$
 $\text{N}:\text{N}:\text{C}:\text{H}_7\text{N}_7$; mw 189.21;
 N 51.83%; cryst; mp, puffs off at approx 97°. Sol in eth; insol in ethanol and w. Prepn is by reacting tetrazole-diazonium chloride with aniline. The product explds on heating
Refs: 1) Beil, not found 2) R. Stollé, Ber 62, 1125-26 (1929) & CA 24, 2748 (1930)

Aminoguanidine, Diazotetrazole—. See in Vol 5, D1176-L & R

Benzylideneaminoguanidine, Diazotetrazole—. See in Vol 5, D1176-R

5-Diazotetrazole. See in Vol 5, D1176-L

Diazotetrazole-Aminoguanidine. See in Vol 5, D1176-L & R

Diazotetrazole-Benzylideneaminoguanidine. See in Vol 5, D1176-R

Diazotetrazole-Phenylhydrazine. See in Vol 5, D1177-L and in Vol 1, A247-R under “N¹-Amino-N²-Phenyl-N³-(Tetrazolyl-5)-Triazine”

Diazotetrazole-Semicarbazide. See in Vol 5, D1177-L

5(4-Dimethylaminobenzeneazo) Tetrazole (or Tetrazole-(5-azo-4)-[N,N-dimethyl-aniline]).

$(\text{CH}_3)_2\text{N}.\text{C}_6\text{H}_4.\text{N}:\text{N}:\text{C}:\text{N}:\text{N}:\text{H}$
 $\text{N}:\text{N}:\text{N}:\text{C}_9\text{H}_{11}\text{N}_7$; mw 217.48; N 45.19%; reddish-peach leaflets (from ethanol); mp, explds at 155°. Sl sol in eth and w. Prepn is by reacting 5-diazo tetrazole with dimethylaniline in a weak soln of HCl, then adding Na acetate to hydrolyze the product
Refs: 1) Beil 26, 593 2) J. Thiele, Ann 270, 54 (1892)

—[N,N-Dimethylaniline], Tetrazole-(5-Azo-4)—. See in Vol 5, D1318-R to D1319-L under “[p-N,N-Dimethylanilino)-(Tetrazolyl-5)]-Diazine”

1-Naphthylamine-(2), Tetrazole-5-Azo.

$(\text{H}_2\text{N})\text{C}_{10}\text{H}_5.\text{N}:\text{N}:\text{C}:\text{N}:\text{N}:\text{H}$
 $\text{N}:\text{N}:\text{C}_{11}\text{H}_9\text{N}_7$; mw 239.27;
 N 40.99%; mp 184° (explds); greenish powder or dk red cryst (from absol ethanol). V sol in aq Na hydroxide; v sl sol in abs ethanol. Prepn is reacting 5-diazo-tetrazole and β-naphthylamine in aq HCl
Refs: 1) Beil 26, 593 2) F.R. Benson, Chem-Revs 41, 1-61 (1947) & CA 41, 6885 (1947)

Phenylhydrazine, Diazotetrazole—. See in Vol 1, A247-R

Semicarbazide, Diazotetrazole—. See in Vol 5, D1177-L

[(Tetrazolyl-5), Carboxamide]: 1,IV-Tetrazene [(1,4-Dihydroisotetrazolyl-5), Carboxamide]: I,IV-tetrazene), (N'-Tetrazolyl-5'), (N-carboxamide-tetrazene), 4-Tetrazolyl-5-tetrazene-1-carboxamide, or Diazotetrazole-semicarbazide).

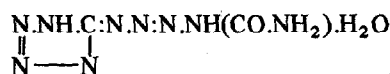
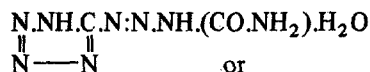

$\text{C}_2\text{H}_6\text{N}_8$ or 9O_2 (?), mw 174.16(?), N 64.35%(?), OB to CO_2 -45.93%(?); white cryst (from w); mp 122° . V sol in w. Prepn is by treating 5-diazo-tetrazole with semicarbazide or acet semicarbazene. The compd explds when heated above 122°

Refs: 1) Beil **26**, (123) 2) K.A. Hofmann & H. Hock, Ber **44**, 2950-51 (1911) & CA **6**, 755 (1912) 3) F.R. Benson, ChemRev **41**, 9 (1947) & CA **41**, 6885 (1947)

II) The bis-Azotetrazoles

5-Azotetrazole (or Bis-5,5'-azotetrazole). See in Vol 1, A659-R to A660-L and the following *Addnl Refs*: 1) H. Morisson, "Chemistry of Tetrazole Explosives Derivatives", IntSymp on "Utilisation Des Éléments Pyrotechniques et Explosifs Dans Les Systèmes Spatiaux", Tarbes (Fr), Dunod (1968); translated by M. Blais, US Army ARRADCOM, Dover (1970) [The impact sensy of various bis-5-azotetrazole salts is presented in Table 7, below

Table 7
Impact Sensitivity of Various
Metal Bis-5-Azo-tetrazole Salts (Ref 1)^a

Compd	Drop Height, mm
Barium Azotetrazole	400
Cadmium Azotetrazole ^b	130
Lead Azotetrazole ^c	120
Potassium Azotetrazole	400
Sodium Azotetrazole	400
Lead Azide (standard)	220

Footnotes to Table 7

a—A.T.S. app, 2kg wt used

b—expln temp is 295°

c—expln temp is 265°

2) J. Prior & W. Siegelin, GerP 2004620 (1971) & CA **75**, 111352 (1971) [The patent claims a safe gas generating compn contg a bis-5-azotetrazole compd which will *not* ignite on falling from a 2-meter height. Thus, pressed elements prepd from 700g of aminoguanidine-5-azotetrazole and 300g of K nitrate were ignited elec-

trically in a press tube provided with a nozzle to give 400cc of gas/g compn] 3) A.J. Barratt et al, "Some Reactions of the Azotetrazole Anion with Dilute Mineral Acids", ERDE-TN-44, Essex (Engl) (1971) (AD-752370) [The authors exposed several of the salts of 5,5'-azotetrazole to ordn sensy tests such as the Rotter, Hotplate and Friction. The results are shown in Table 8.

Infra-red spectra of the sodium, 1,1' lead, and 1,1' silver salts of 5,5'-azotetrazole are included] 4) A.T. Thomas & R.J. Williams, "Fuse Heads", USP 3763783 (1973) & CA **80**, 17084 (1974) [Electrically initiated (by resistance-wired bridges) fuse heads contg Pb-Azo-tetrazole are claimed in this patent. Thus, typically, sufficient wet Pb-Azotetrazole particles 6-10 microns long and 1-2 microns wide to give 8.08g of dry Pb-Azotetrazole, adjusted to include 2.0g w and 5cc of an aq suspension contg 5% methyl cellulose, is mixed to give a smooth paste. Bridge wires are then immersed in the paste, withdrawn, and the fuse heads so formed are allowed to dry]

1,1'-Azo-5,5'-d-o-Chlorophenyl-Tetrazole. See in Vol 2, B139-L

1,1'-Dimethyl-5,5'-Azotetrazole. See in Vol 5, D1320-L and in Vol 2, B151-L under "Bis (1-Methyl-1,2,3,4-Tetrazolyl-5)-Diazene"

The Dinaphthylazotetrazoles and Derivatives. See in Vol 5, D1379-R to D1380-L

Diphenylazotetrazoles. See in Vol 5, D1444-L & R

Hydrazide, Bis-Diazotetrazole. See in Vol 1, A260-R to A261-L under "[N¹,N⁶-Bis (α-Tetrazolyl-5)]-Hexazadiene"

5,5'-Hydrazo-Bis-1H-Tetrazole. See in Vol 7, H211-R

5,5'-Hydrazotetrazole. See in Vol 2, B157-R under "5,5'-Hydrazo-bistetrazole" and in Vol 7, H211-R

The Monotriethyl Lead Salt of 1,3-Bis (1H-Tetrazolyl-5)-Triazine. See in Vol 2, B158-R

Table 8
Sensitiveness of Products and Evaporation Residues of Bis-5,5'-Azotetrazole (Ref 3)

Sample	Rotter Test RMH, cm	Train Test or Hotplate Test	Friction		
			Mild Steel	Naval Brass	Al Bronze
Silver-bis-5-azidotetrazole	Too sensitive to handle. When dry will explode if touched with rubber spatula				
5-Azidotetrazole	Can be handled when dry but very destructive when explodes				
5-Hydrazinotetrazole monohydrochloride	111	Flashes and crackles on hotplate	—		
Brown product from Na ₂ AT ^a ·H ₂ SO ₄ (5N) cold	33	Flash	0/10	2/10 burns	1/10 burns
*Na ₂ AT·5H ₂ O + HNO ₃	192	Exploded on hotplate	—		
*Na AT·5H ₂ O + HCl	88	Crackles, smokes, does not support train	0/10	0/10	0/10
Na ₂ AT·5H ₂ O + warm H ₂ SO ₄ (5N)		Hygroscopic—not tested	—		
*Na ₂ AT·5H ₂ O + Ce Amm NO ₃	Out of range	No ignition	0/10	0/10	0/10
*PbAT.Pb(OH) ₂ (RD 1355) + acetic acid	Explodes, unreacted PbAT.Pb(OH) ₂ present				
*Na ₂ AT·5H ₂ O soln + CO ₂	Out of range	No ignition	—		
*PbAT.Pb(OH) ₂ (RD 1355) + HNO ₃ (5N)	111	Exploded on hot plate	0/10	0/10	0/10
*PbAT.Pb(OH) ₂ (RD 1355) + HCl (5N)	151	Crackles and smokes	0/10	0/10	0/10
*PbAT.Pb(OH) ₂ (RD 1355) + H ₂ SO ₄ (5N) (recommended method of destruction)	—	No ignition	—		

Footnotes to Table 8:

a—the designation "AT" is equivalent to bis-5,5'-azotetrazole

*—Evaporation residue

5-Oxy-1,5'-Azotetrazole. See in Vol 8, O55-L

1,2,3,9-Benzoisotetrazole (or 1,2-Dihydropyrido [2,1e] tetrazole).

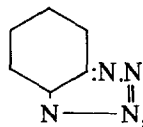

N—N, C₅H₄N₄; mw 120.13; N 46.70%;

colorl, elongated prisms; mp 159°. Sol in warm ethanol, acet and w; insol in cold w or eth.

Prepn is by reacting a dil acetic acid soln of 2-pyridylhydrazine with an aq soln of Na nitrite at 0°. The compd explds when touched with a red-hot rod

Refs: 1) Beil, not found 2) R.G. Fargher et al, JCS 107, 689-99 (1915) & CA 9, 2890 (1915)

5,5'-Bis (α - or 1,2,3,4-Tetrazole). See in Vol 2, B157-L & R

3,6-Bis (2H-Tetrazolyl-5)-Sym. See in Vol 2, B158-L

Bis-[1-Hydroxy-5-Tetrazole]. See in Vol 2, B148-L & R under "5,5'-Bis (1-Hydroxytetrazole)"

(5'-Carboxypyrido)-1',2':4,5-Tetrazole. See in Vol 2, C66-L & R

5-Cyano-(α -Tetrazole). See in Vol 3, C588-R to C589-L

Diphenyltetrazole and Derivatives. See in Vol 5, D1481-R to D1482-R

Ethoxyphenyltetrazole and Derivatives. See in Vol 6, E194-L & R

N'-N-Hexazadieno-Di(5-Tetrazole). See in Vol 7, H91-L & R under "Hexazadienes"

5-Hydrazino-Tetrazole (Tetrazyl-5-Hydrazine).

$$\text{H}_2\text{N.HN.C.NH.N}$$

$$\text{N} \text{---} \text{N}, \text{CH}_4\text{N}_6; \text{mw } 100.11; \text{N } 84.0\%;$$

cryst (from w); one of the richest compds in N content; mp 199° (decompn). Sol in alkalies and ammonia; sl sol in w; insol in ethanol, benz, and eth. Prepn is by redn of tetrazole diazonium chloride with stannous chloride in the presence of HCl. The compd explds when heated above its mp

Refs: 1) Beil **26**, 405 2) J. Thiele et al, Ann **273**, 155 (1893) 3) Ibid, **287**, 235 (1895) 4) Ibid, **303**, 62 (1898) 5) E. Lieber & G. Smith, ChemRevs **25**, 240 (1939) & CA, not found 6) F.R. Benson, ChemRevs **41**, 8 (1947) & CA **41**, 6885 (1947)

1-Hydroxytetrazole (1-Oxytetrazole).

$$\text{C.N(OH).N}$$

$$\text{N} \text{---} \text{N}, \text{CHN}_4\text{O}; \text{mw } 85.06; \text{N } 65.92\%; \text{OB to CO}_2 \text{ } -28.22\%; \text{slender acicular cryst, v volatile; mp, expl decompn on heating ca } 145^\circ. \text{Sol in acet, w, acetic acid, ethanol and methanol; sl sol in eth; insol in benz and C disulfide. Prepn is by treating 2 moles of hydrazoic acid with 1 mole of Na fulminate in w. The compd is re-$$

ported as having a lower power and brisance than PA

Refs: 1) Beil **26**, (109) 2) F.C. Palazzo, AttiR AcadLincei **19** [5], I, 218-22 (1910) & CA **4**, 2455 (1910) 3) F.C. Palazzo & G. Marogna, Gazz **43**, I, 71, 569 (1913) & CA **7**, 1724 (1913) 4) Ibid, JCS **104**, I, 300 (1913) & CA, not found

5-Hydroxytetrazole [5-Oxytetrazole, Oxo-tetrazolin, Oxy-5-tetrazole or Tetrazolol (Ger)].

$$\text{HO.C.NH.N}$$

$$\text{N} \text{---} \text{N}, \text{CH}_2\text{N}_4\text{O}; \text{mw } 86.07; \text{N } 65.11\%; \text{OB to CO}_2 \text{ } -37.18\%; \text{cryst; mp } 250-54^\circ. \text{V sol in acet, ethanol, eth, methanol and w. Prepn is by redn of Cu oxide with tetraolediazonium hydroxide, or by treating K-tetrazole sulfonate with K hydroxide, dissolving the product in w and acidifying with dil sulfuric acid. The compd forms expl salts: } \textbf{Mercuric Salt}$$
—a white solid which explds on heating. **Silver Salt**—Ag₂CON₄; mw 299.79; N 18.69%; white solid, explds violently on heating, but is insensitive to impact
 Refs: 1) Beil **26**, 403 & (121) 2) M. Freund & T. Paradies, Ber **34**, 3119-20 (1910) & CA, not found 3) R. Stolle & G. Adam, Ber **57**, 1658 (1924) & CA, not found 4) Ibid, Ber **62**, 1122 (1929) & CA, not found

The Methyl Tetrazoles and Derivatives

1-Methyl Tetrazole [Methyl-1-tetrazol (Ger)].

$$\text{CH}_3$$

$$\text{N-N}$$

$$\text{N-N=C}$$

$$\text{N-N}, \text{C}_2\text{H}_4\text{N}_4; \text{mw } 84.10; \text{N } 66.63\%; \text{prisms (from eth); mp } 36-37^\circ. \text{V sol in ethanol and w; sl sol in benz and hot eth; insol in cold eth. Prepn is by heating a mixt of 1-methyl-mercapto tetrazole with dil acid on a w bath, or by treating tetrazole with diazomethane. It forms expl salts: } \textbf{Silver Salt}$$
—AgC₂H₃N₄; white ndles; mp, decompn at about 107°. Prepn is by adding an ethanolic soln of Ag nitrate to ethanolic 1-methyl tetrazole. Explds mildly when heated on a spatula at above 107°

Refs: 1) Beil **26**, (108) & [196] 2) F.R. Benson, "The Chemistry of the Tetrazoles", ChemRevs **41**, 1-61 (1947) & CA **41**, 6885 (1947)

5-(β-Hydroxyethyl)-1-Methyl Tetrazole.

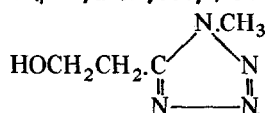

 $\text{HOCH}_2\text{CH}_2\text{C}$

 $\text{C}_4\text{H}_8\text{N}_4$; mw 113.16; N 49.52%; liq of 52cp visc. Sol in acet. Prepn is by saponifying 1-methyl-5-vinyl tetrazole with aq Na hydroxide and then hydrolyzing with hydrochloric acid. The product is extracted from the reaction mixt with acet. The inventor claims the product to be a high energy proplnt plasticizer which serves to improve the mech props of proplnts in which it is incorporated

Refs: 1) Beil, not found 2) H.S. Haiss, USP 3564005 (1971) & CA 74, 112805 (1971)

1-Methyl-5-Nitrosamino-Tetrazole.

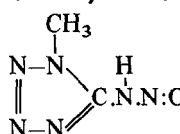

 $\text{C}_2\text{H}_4\text{N}_6\text{O}$; mw 128.12; N 65.61%; OB to CO_2 -62.44%; leaflets (from w); mp, explds at 177°. V sol in hot w and hot eth; sol in Na hydroxide and alkalies; sl sol in ethanol and w. Prepn is by reacting a soln of 1-methyl-5-amino-tetrazole in 2N HCl with an aq soln of Na nitrite at 0°

Refs: 1) Beil, not found 2) R. Stolle et al, "Tetrazoles", JChem 134, 282-309 (1932) & CA 26, 5565 (1932)

2-Methyl-5-Vinyltetrazole.

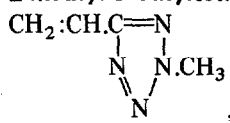

 $\text{CH}_2\text{:CH.C=N}$

 $\text{C}_4\text{H}_6\text{N}_4$; mw 110.14; N 50.89%; colorl liq. Sol in dimethylformamide (DMF). CA Registry No [15284-39-6]. Prepn according to Ref 3 is as follows: "... Agitate and heat at 122-124 degrees Centigrade (°C) for 24 hours, a slurry consisting of 196 grams (g) (2.00 moles) of dimethylaminopropionitrile, 144 g (2.20 moles) of sodium azide, 180 g (2.20 moles) of dimethylammonium chloride, and 750 milliliters (mℓ) of dimethylformamide. As soon as the temperature reaches about 115°C, a vigorous evolution of dimethylamine will begin. Amine is trapped in 300 mℓ of 95 percent ethanol, and cooled in a dry ice-acetone bath. Titration of an aliquot will indicate that 1.44 moles are evolved (in check ex-

periments this will vary from 1.44 to 1.62 moles)

When the heating period is completed, cool the solution to 70°C and rapidly remove the dimethylformamide under reduced pressure (20-30 millimeters (mm)). Thorough removal of this solvent is necessary in order to obtain high purity 2-methyl-5-vinyltetrazole. Under the best conditions 720 to 750 mℓ of dimethylformamide can be removed

Dissolve the gummy residue in 1000 mℓ of water; add 168 g (2.00 moles) of sodium bicarbonate and 1.0 g of trinitrobenzene (inhibitor). Methylate this solution at 32-35°C with 400 mℓ of dimethyl sulfate (4.3 moles). External cooling is needed in order to maintain the temperature. This procedure requires about 45 minutes to complete the addition. When all of the methylating agent is added, stir the solution for 30 minutes more at 32-35°C. Some gas (probably carbon dioxide) is evolved during the methylation. Next add 84 g (1.0 mole) sodium bicarbonate and 53 g (0.50 mole) of sodium carbonate, and reflux the solution for five hours. Stir to prevent bumping and frothing. Because of the large gas evolution (carbon dioxide plus trimethylamine) an efficient condenser is also required

Cool the mixture to 25°C, and filter to remove separated salts. The pH of the solution will be between 8 and 8.5

Extract the aqueous phase with six 250-mℓ portions of methylene chloride; wash the solid cake with three of the portions prior to their use on the solution. Dry the combined extracts over 40 g of anhydrous magnesium sulfate and inhibit with 0.5 g of hydroquinone. Remove the drying agent by filtration and strip the methylene chloride by distillation at atmospheric pressure; remove final traces of this solvent by stripping at 20 mm pressure and room temperature. Then separate the mixture of crude vinyl isomers by distillation at reduced pressure. By heating to a pot temperature of 90°C, the 2-methyl-5-vinyltetrazole is conveniently and almost completely removed at 1.0 mm pressure. A well cooled condenser and a receiver chilled in an ice-water bath are needed to prevent loss of the condensate. The weight of once distilled 2-isomer is 89.9 g; the index of refraction at 25°C is 1.4814, corresponding to a purity of 97.2 percent. The corrected yield amounts to

39.7 percent of theory . . .”

2-Methyl-5-vinyl tetrazole can be readily polymerized in a number of ways to yield high mw soluble polymers or **Poly-2-Methyl-5-Vinyl-Tetrazole (PMVT)**. Again, according to Ref 3 the following polymerization procedure is used for processing the monomer into PMVT:

“ . . . (a) Place benzotrifluoride solvent into a kettle. Connect condenser and start cooling water through it. Allow helium to bubble slowly through the solvent. Insert a thermometer in solvent in kettle. Turn on stirrer

(b) Heat solvent to 80°C and maintain steady temperature for one hour. Degas monomer if necessary

(c) Add α, α' azobisisobutyronitrile catalyst to kettle continuing agitation, helium bubbling and maintain constant 80°C temperature for five minutes

(d) Add monomer five minutes after catalyst addition. Withdraw small samples of mixture at one minute intervals after monomer addition

(e) At first signs of cloudiness in the solution:

1. Turn off the stirrer
2. Withdraw bubbler tube from solution and allow helium to flow just below the top of the kettle
3. Closely watching thermometer, turn off steam. Solution should be maintained at 80°C

(f) Heat of reaction should be released in 15 to 20 minutes at which time it will be necessary to readmit steam to maintain 80°C temperature in the kettle. Hold kettle at this temperature for six hours

(g) Remove resulting slurry from the kettle and filter off the polymer. Return solvent to storage container. Retain filter cake on vacuum filter flask until quite dry and crumbly. Recovered solvent may be used to wash down walls of reaction kettle. Refilter the solution. Last traces of polymer may be removed from the kettle with chloroform

(h) Break up polymer cake and place in drying trays. Vacuum dry at 60°C. This operation may take several days to remove last traces of solvent . . .”

The purified polymer is brittle but can be plasticized by a wide variety of compds. It has found use as a rocket propellant igniter-binder and as a fuel-binder by the US Navy for composite

propellants (Refs 3a & 4). Indeed, Haiss & Lowe (Ref 5) patented a compn contg the tetrazole which they claim to be a fluid or rubbery terpolymer useful as a fuel-binder in propellant compns. Thus, DMF contg 150/150/20 (mole ratio) 2-methyl-5-vinyltetrazole/ethyl acrylate/acrylic acid mixt, 2-mercaptoethanol, and azobisisobutyronitrile is heated for 2 hrs at 80° to give a 76.0% yield of an acrylic acid-ethyl acrylate-2-methyl-5-vinyltetrazole copolymer of 1980 mw. Similarly, Chang et al (Ref 6) claim a solid composite compn which is cool-burning and produces only noncorrosive products including a high percentage of gas. Thus, a mixt contg 5-aminotetrazole nitrate (71.5), hydrazinium-5-nitroaminotetrazole (8.5) and a binder (consisting of 45% each of 2-methyl-5-vinyltetrazole and 2-methoxy ethyl methyltetrazole, methyl acrylate 6% and cumene hydroperoxide 4%) (20%), is cured to form grains having a burning rate of 0.753in/sec at 100psi and 77°F. Another use of vinyl tetrazoles is reported by Schroeder and Inatome (Ref 5a), who claim that cloth backed with a laminar coating of poly (2-methyl-5-vinyltetrazole), used as a testing technique, is as effective in minimizing gun barrel wear as the standard XM-1 Swedish additive, but not as efficient as polyurethane foam. They conclude that gas-generating materials of the vinyl tetrazole type could be developed to serve as excellent wear-reducing additives

Refs: 1) Beil, not found 2) W.G. Finnegan & R.A. Henry, “Synthesis of Substituted Vinyl-tetrazoles”, **NAVORD 5405** (1959) (Limited dist) 3) Anon, “Instructions for Preparation of Binder, Poly (2-Methyl-5-Vinyltetrazole)”, **NAVWEP CENTR-Spec-OD-24521**, China Lake (1962) (AD-848260) 3a) L.A. Burkardt et al, **USP 3332353** (1967) & **CA 67**, 100663 (1967) 4) G. Cohn, Ed, **Expls&Pyrots 4** (8), Franklin Inst, Phila (1971) 5) H.S. Haiss & J.V. Lowe, **USP 3700636** (1972) & **CA 78**, 73365 (1973) 5a) M.A. Schroeder & M. Inatome, “The Relationship Between Chemical Composition and Wear-Reducing Effectiveness of Some Laminar Additives for Gun Propellants: Polyvinyltetrazole”, **BRL-MR-2512** (1975) 6) M.S. Chang et al, **USP 3909322** (1975) & **CA 84**, 138049 (1976)

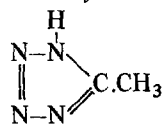
5-Methyl-Tetrazole.

$C_2H_4N_4$; 84.10; N 66.63%; colorless (from 2:5 ethyl acetate/petr eth); mp 145–47°. Sol in hot ethyl acetate, ethanol, eth and methanol. Prepn is by reacting acetonitrile with Na azide in acetic acid soln. Evapn of the reaction mixt to dryness gives a waxy solid from which the product can be extracted with boiling ethyl acetate. Upon evapn of the solvent, the product crystallizes out; recrystn is accomplished using a 2:5 ethyl acetate/petr eth mixt. Final purification of the product is by vac sublimation. The yield is 15%. Ref 3 considers the following salts of the compd to be candidates for fuze train incorporation:

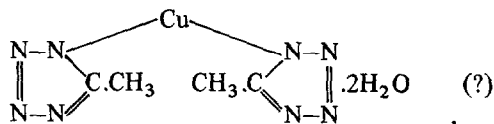
Copper-Bis-5,5'-Methyl Tetrazole.

$Cu(C_2H_3N_4)_2 \cdot 2H_2O$; mw 265.77; N 42.17%; mp, ignites at 280°. Prepn is by reaction between aq solns of Cu nitrate and Na-5-methyl tetrazole. Pptn of the salt is accomplished by drowning in acet

Silver -5-Methyl Tetrazole. $AgC_2H_3N_4$; mw 190.96; N 29.35%; mp, ignites at 335°. Prepn is similar to the Cu salt

Refs: 1) Beil 26, (110) 2) F.R. Benson, "The Chemistry of the Tetrazoles", ChemRevs 41, 1–61 (1947) & CA 41, 6885 (1947) 3) L.R. Bates & J.M. Jenkins, "The Salts of 5-Substituted Tetrazole . . . 5-Methyl Tetrazole", ERDE-TN-25 (1970) (AD-727350)

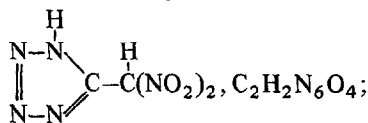
5-Dinitromethyltetrazole.

$C_2H_2N_6O_4$; mw 174.08; N 48.28%; OB to CO_2 -9.19%; white cryst; mp, fumes at 100°, darkens above 150°, decompn ca 180° without melting. Sol in w producing a deep yel, highly acidic soln. Prepn is by stirring and refluxing an aq mixt of Na dinitroacetonitrile, Na azide and amm chloride for 24 hrs. After cooling the mixt, the diammonium tetrazole ppt is filtered off and dis-

solved in an excess of hot 10% HCl to form crystn amm bitetrazole upon cooling to 5°. The amm bitetrazole is then filtered off, leaving a filtrate contg the desired 5-dinitromethyl tetrazole. The product is recovered from this filtrate by adjusting the pH to <1 with concd HCl, removing the hydrazoic acid and w by-products with w aspiration on a steam bath, and extraction of the crude 5-dinitromethyl tetrazole with boiling acet. With subsequent evapn of the acet and extraction of the desired product from the residual solids with eth, then evapn of the eth, the product is finally crystd from methyl alcohol in a yield of 8.0%. Ref 3 terms the compd to be of importance in both expls and proplntg. It forms the expl salt **Monosodium-5-Dinitrotetrazole** $NaC_2HN_6O_4$; mw 240.08; N 42.73%; OB to CO_2 -3.33%; cryst; mp, violently explds ca 160°. Sol in w. Prepn is by titrating 5-dinitromethyltetrazole in aq ammonia to the first electrometric end pt with 0.1N Na hydroxide, removing the w, and washing the salt with ethanol and then acet before drying

Refs: 1) Beil, not found 2) F. Einberg, "Preparation of 5-Dinitromethyltetrazole from Salts of Dinitroacetonitrile", JOC 29, 2021–24 (1964) & CA 61, 9489 (1964) 3) Anon, "Research Activities and Facilities Report", Pittman-Dunn Labs, Frankford Ars, Phila (Feb 1974)

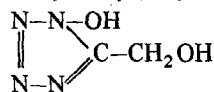
1-Hydroxy-5-Hydroxymethyltetrazole.

$C_2H_3N_4O_2$; mw 115.09; N 48.69%; OB to CO_2 -48.66%; mp, v volatile. Prepn is by treating 5-azido tetrazole with formaldehyde in aq soln. Ref 2 terms this compd an expl with less brisance and power than PA

Refs: 1) Beil, not listed 2) Blatt, OSRD 2014 (1944)

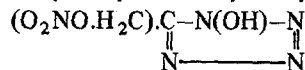
1-Hydroxy-5-Nitroxymethyltetrazole.

$C_2H_3N_5O_4$; mw 161.10; N 43.48%; OB to CO_2 -14.90%; mp, explds on heating. Prepn is probably by nitration of 1-hydroxy-5-methyltetrazole with dil nitric acid in the cold (?). The compd explds on heating or impact. It is less powerful and brisant than PA, but is more sensitive to impact

Refs: 1) Beil, not found 2) Blatt, OSRD
2014 (1944)

5-Methylmercapto-Tetrazole.

CH₃S-C-NH-N
|| ||
N=N, C₂H₄N₄S; mw 116.16; N
48.24%; white colorl prisms; mp 151° (with
decompn, starts to fuse and sinter at ca 144°).
Prepn is by treating s-methyl-thiosemicarbazide
with a HCl soln of Na nitrite. The compd forms
the following expl salts:

Copper Salt. Cu(C₂H₃N₄S)₂; mw 295.85; N
37.88%; greenish solid; mp, starts to decomp at
over 230°, deflagrates violently in an open flame

Silver Salt. AgC₂H₃N₄S; mw 223.02; N 25.13%;
white solid which detonates violently when
heated in an open flame. Rathsburg (Ref 3)
patented the use of these salts in detonators and
percussion caps

Refs: 1) Beil 26, 393 2) M. Freund & T.
Paradies, Ber 34, 3115-16 (1901) 3) H.
Rathsburg, BritP 185555 (1922) & CA 17,
1147 (1923)

5-Methylsulfone-Tetrazole [5-Methyl-sulfone-
tetrazole or Methyl tetrazol sulfone (Ger)].

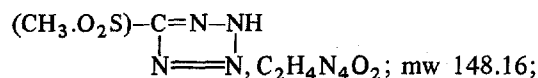
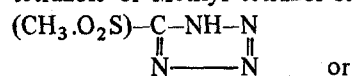

N 37.82%; white cryst (from ethanol); mp 120°
(starts to sinter at 110°). V sol in ethanol, eth,
chl, benz, ligr and w. Prepn is by treating 5-
methyl mercaptotetrazole with aq sulfuric acid.
The compd forms several expl salts:

Potassium Salt. (CH₃.O₂S).C=N-N.K
||
N=N,

KC₃H₃N₄O₂S; mw 186.24; N 30.09%; OB to
CO₂ -30.07%; cryst (from aq ethanol-eth). V
sol in w; sl sol in ethanol; insol in benz, chl, and
eth. Prepn is by reacting K permanganate with
5-methyl-mercapto tetrazole. The salt explds
violently when heated in an open flame

Silver Salt. AgC₂H₃N₄O₂S; mw 255.02; N
21.97%; OB to CO₂ -21.96%; amorph solid; mp,
explds on heating. Prepn is by treating an aq
soln of the K salt with Ag nitrate

Refs: 1) Beil 26, 394 2) M. Freund & T.
Paradies, Ber 34, 3116 (1901)

5-Nitrotetrazole and Derivatives

E. vonHerz (Refs 2 & 3) first proposed using
the w-insol heavy metal salts of 5-nitrotetrazole;
ie, Ag, Hg and basic Pb, as initiating substances.
It has been claimed that the initiating power of
these salts (when comparing the loading limits)
exceeds even that of Pb Azide (LA). This can be
seen from the following data which gives the
grams required to initiate equal amts of Tetryl:
LA 0.02, basic Pb-5-nitrotetrazole 0.02, Hg-5-
nitrotetrazole 0.006, and Ag-5-nitrotetrazole
0.005g

It has been claimed that in contrast with LA,
the 5-nitrotetrazole salts possess the advantage
of good inflammability even in a moist environ-
ment. Their stability is not influenced by the
presence of CO₂ and they may be stored without
deterioration in hot climates. Additionally,
these compds develop extremely high temps on
combustion or expln. If it is desirable to raise
the thermic effect, brisance, sensitivity, etc, of
the 5-nitrotetrazoles they may be combined with
oxygen carriers, combustible substances, abra-
sives, etc, for use in priming compns. To this end
the US Navy is currently proceeding to replace
LA with Hg-5-nitrotetrazole (Ref 8)

Presented next are data on individual 5-
nitrotetrazole compds of interest:

5-Nitrotetrazole (NT).

N-NH
|| \ C.NO₂
N=N

, CHN₅O₂; mw 115.07; N
60.88%; OB to CO₂ -6.95%; deliq cryst; mp,
extremely sensitive, explds under the slightest
stimulus. Due to the fact that the H-atom which
is to be substituted is negatively influenced by
the strongly acid tetrazole nucleus, it is not
possible to prepare NT by the direct nitration of
tetrazole. Instead, an indirect procedure pa-
tented by vonHerz (Refs 2 & 3) based on the
Sandmeyer reaction, and improved by Gilligan
and Kamlet (Refs 9 & 11a) is used. Essentially,
the method consists of treating a coned acidic
soln of 5-aminotetrazole with an excess of Na
nitrite in the presence of finely divided Cu or its
salts. It is reported that the best results are ob-
tained when using an aq soln of Cu (ic) nitrite
prepd by simultaneously dissolving in w, Cu

sulfate and Na nitrite. According to Refs 8, 9 and 12, the following reactions occur in the prepn of bis(ethylenediamine) copper (II)-bis(5-nitrotetrazole) (or $\text{Cu en}_2(\text{NT})_2$):

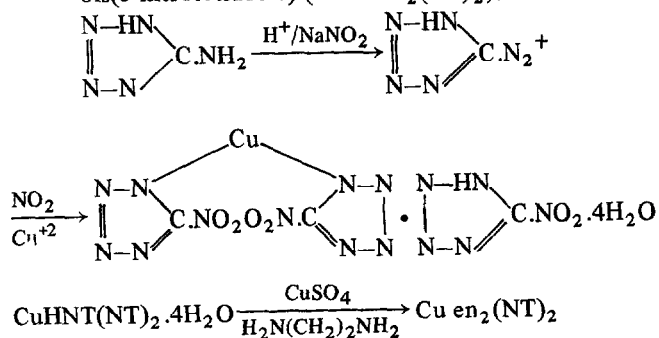

The acid Cu salt crystallizes as thin blue ndles. This compd, bis(ethylenediamine) Cu (II) bis-(5-NT), serves as the starting material for the prepn of other salts, some of them extremely expl. The *free* 5-Nitrotetrazole can then be prepd by treating the warm aq suspension of the Cu salt with H_2S , extracting with benz or ethyl acetate and evapg the filtrate until a syrupy consistency is obtd. On further evapn in vacuo, a very deliq crystn mass is obtd which possesses the properties of a very strong acid. Free 5-Nitrotetrazole is a *violent* expl, however it is not suitable for expl use because of its extreme hygroscopicity. According to Jenkins (Ref 5), if acidified with normal HCl, NT becomes an unstable viscous mass which will expld violently without any external stimulus after a period of from 2 to 3 weeks in storage at RT

The Salts of 5-Nitrotetrazole

1-Sodium-5-Nitrotetrazole (Na-NT).

$\begin{array}{c} \text{Na} \\ | \\ \text{N}-\text{N} \\ \parallel \\ \text{N}-\text{N} \\ \diagup \quad \diagdown \\ \text{C.NO}_2 \end{array}$, $\text{CN}_5\text{O}_2\text{Na}$; mw 137.05; N 51.11%; OB to CO_2 0%; colorl cryst with from 2 to 4 moles of w of crystn. V sol in w. Prepn is by treating a suspension of $\text{Cu en}_2(\text{NT})_2$ in boiling water with Na hydroxide, filtering off the Cu oxide which forms during the reaction, and evapg the filtrate to obtn crystals of the salt. The Na salt can be used as the starting material for the prepn of both the mercuric and the silver

salts. According to Gilligan and Kamlet (Ref 9) the hydrated Na salt is relatively insensitive to shock; it cannot be detonated with a hammer blow. However, when completely dry, the Na salt is a sensitive expl

Basic 1,1'-Lead bis-5,5'-Nitrotetrazole.

$\begin{array}{c} \text{N:N:N} - \text{Pb} - \text{Pb} - \text{N:N:N} \\ | \quad | \quad | \quad | \\ \text{N}=\text{C}(\text{NO}_2)(\text{O}_2\text{N}) \cdot \text{C}=\text{N} \end{array}$, $\text{C}_2\text{N}_{10}\text{O}_4\text{Pb}_2$; mw 642.52; N 21.80%; OB to CO_2 0%; pale yel granular crysts; mp, detonates at 220° . Sol in hot w; sl sol in cold w. Prepn is by saturating a hot (80°) 10% soln of free 5-Nitrotetrazole with two milliequiv of Pb peroxide. The mixt is stirred rapidly while hot, and on cooling the product crystallizes out. The basic Pb salt is detonated on impact or friction, being more sensitive to percussion than MF because of its brittleness

Mercury-5,5'-Nitrotetrazole (1,1'-Mercury-bis-5-nitrotetrazole).

$\begin{array}{c} \text{N:N:N} - \text{Hg} - \text{N:N:N} \\ | \quad | \quad | \quad | \\ \text{N}=\text{C}(\text{NO}_2)(\text{O}_2\text{N}) \cdot \text{C}=\text{N} \end{array}$, $\text{C}_2\text{N}_{10}\text{O}_4\text{Hg}$; mw 428.71; N 32.68%; OB to CO_2 0%; dense granular crysts; mp, deton at 215° . Sol in 20% aq amm acetate soln; v sl sol in w; insol in nitric acid. CA Registry No [60345-95-1]. Lab prepn, according to Ref 9, are as follows:

I. From Na 5-Nitrotetrazole:

Reagents: $\text{Hg}(\text{NO}_3)_2$ soln. Dissolve 54.0g of red mercuric oxide in 200ml of 35% HNO_3 . Filter and dilute the filtrate to 250ml with 35% HNO_3

Procedure: Dissolve 16.7g of Na 5-Nitrotetrazole in 188ml w. Add 12ml 70% HNO_3 and place a magnetic stirring bar in the soln. In a separate container, add 60ml of the $\text{Hg}(\text{NO}_3)_2$ soln to 140ml of w. Heat both the tetrazole soln and the $\text{Hg}(\text{NO}_3)_2$ soln to 75° in a w bath

Remove the solns, quickly add the $\text{Hg}(\text{NO}_3)_2$ soln to the tetrazole soln and begin stirring at slowest speed possible. Allow to cool gradually to ca 30° with continuous stirring while the mercuric salt crystallizes. Stop the stirring, allow the mercury salt to settle and then decant the supernatant liq. Transfer the solids to a "Nalgene" beaker by means of a w wash bottle. Add 200ml of w, swirl, and again decant

Transfer about 1/3 of the solids to a small

"Nalgene" buchner funnel (No 2 Whatman paper) by means of a w wash bottle and wash consecutively with 50ml w, twice with 50ml of methanol, and finally with 50ml of methylene chloride. Air dry on the funnel. Carefully transfer the dried salt by gently pouring the contents into a weighed wide-mouth conductive plastic container. After weighing, place mercuric salt into a blast-proof container. Repeat filtration and washing for remainder of product. Yield is 75 to 80% of theory based on Na-5-Nitrotetrazole II. From bis (Ethylenediamine) Copper (II) bis (5-Nitrotetrazole) [$\text{Cu en}_2(\text{NT})_2$]:

Reagents:

- A. 100g $\text{Cu en}_2(\text{NT})_2$ in 1100ml w at 75°
 B. 65ml of 70% nitric acid in 160ml w
 C. 4ml of 70% nitric acid in 225ml of 1.0 molar Hg (ic) nitrate

Procedure: Add soln B to A, dropwise, with stirring at 75° to 80° over a period of 15 mins. Then add soln C in the same manner over a period of 55 mins. Stir for 15 mins, then allow to cool to 55°. Decant the supernate from the solid product and wash by decantation 5 times with 500ml w. Transfer the product to a plastic bottle with a w wash bottle and store under w. Yield is about 92g (89%)

Equations for the conversion of the ethylene diamine complex to Mercuric-5-Nitrotetrazole are:

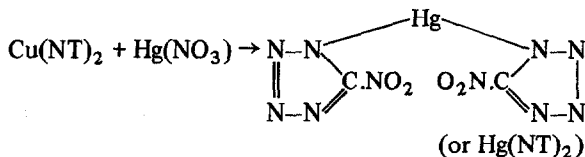
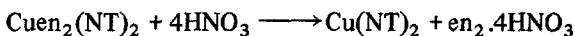

A "scale-up" of procedure II for plant prepn, according to Ref 8, is as follows:

Reagents:

- A. 5500ml of 80° w added to 1.21 moles of $\text{Cu en}_2(\text{NT})_2$
 B. 800ml of w mixed with 325ml of 70% nitric acid
 C. 1275ml of aq 1 molar Hg (ic) nitrate soln mixed with 22ml of 70% nitric acid soln

Procedure: Equipment is set up as shown in Fig 1, except that the immersion coil is not used in the reactor. Soln A was prepd in the reactor by adding 80° w to $\text{Cu en}_2(\text{NT})_2$. Soln B is added over 30 mins. When a green slurry is not

obtd, approximately 10% additional nitric acid is added. Soln C is added over about one hr, and two liters of 75° w are added to dissolve the unreacted $\text{Cu}(\text{NT})_2$ splashed on the reactor walls. The $\text{Hg}(\text{NT})_2$ slurry is cooled to 55° and filtered with a 6 centimeter diam flat faced polypropylene immersion filter having 35 micron pores. The product is washed five times with w in less than one hr. Each wash is two liters and is agitated before being filtered. Three liters of w is then added and the $\text{Hg}(\text{NT})_2$ is hydraulically transferred to plastic shipping containers using the device illustrated in Fig 2. Because drying of the product is prohibited and its sensitivity is unknown, yields of Mercuric-5-Nitrotetrazole are conservatively estimated at 80% as based on the intermediate $\text{Cu en}_2(\text{NT})_2$

Caution:

Mercuric 5-Nitrotetrazole is a powerful primary expl! It detonates at 7cm (2.5kg wt) on the Naval Surface Weapons Center impact machine, is sensitive to friction, and has an expln temp of 210°. All operations should be carried out behind a safety screen with the minimum exposure, by experienced personnel

Further safety data relative to this compd and its intermediates is shown in Table 9

Analysis of Mercuric 5-Nitrotetrazole (Refs 8 and 12):

The 5-nitrotetrazole ring has a max in the ultraviolet at 257m μ , which can be used for analysis. The molecular extinction coefficient is 5.4×10^3

About 60mg of Mercuric 5-Nitrotetrazole is dissolved in 20ml of 20% amm acetate soln and then dild to 250ml with w. A second dildn of about one to ten is then made with 2% amm acetate soln and the absorption is measured at 257m μ against a reagent blank

Sodium 5-nitrotetrazole dihydrate which is recrystd twice from w and three times from acet and then air dried is used to prepare a standard curve

Uses:

vonHerz (Refs 2 & 3) reports that the addn of 10% Hg-5-NT to MF allows reducing the amt of MF required to initiate Tetryl from 0.23g to 0.04g, and the addn of 20% Hg-5-NT further reduces this amt to 0.02g. Scott & Leopold (Ref 7) claim the compd to be a sensitive, stable,

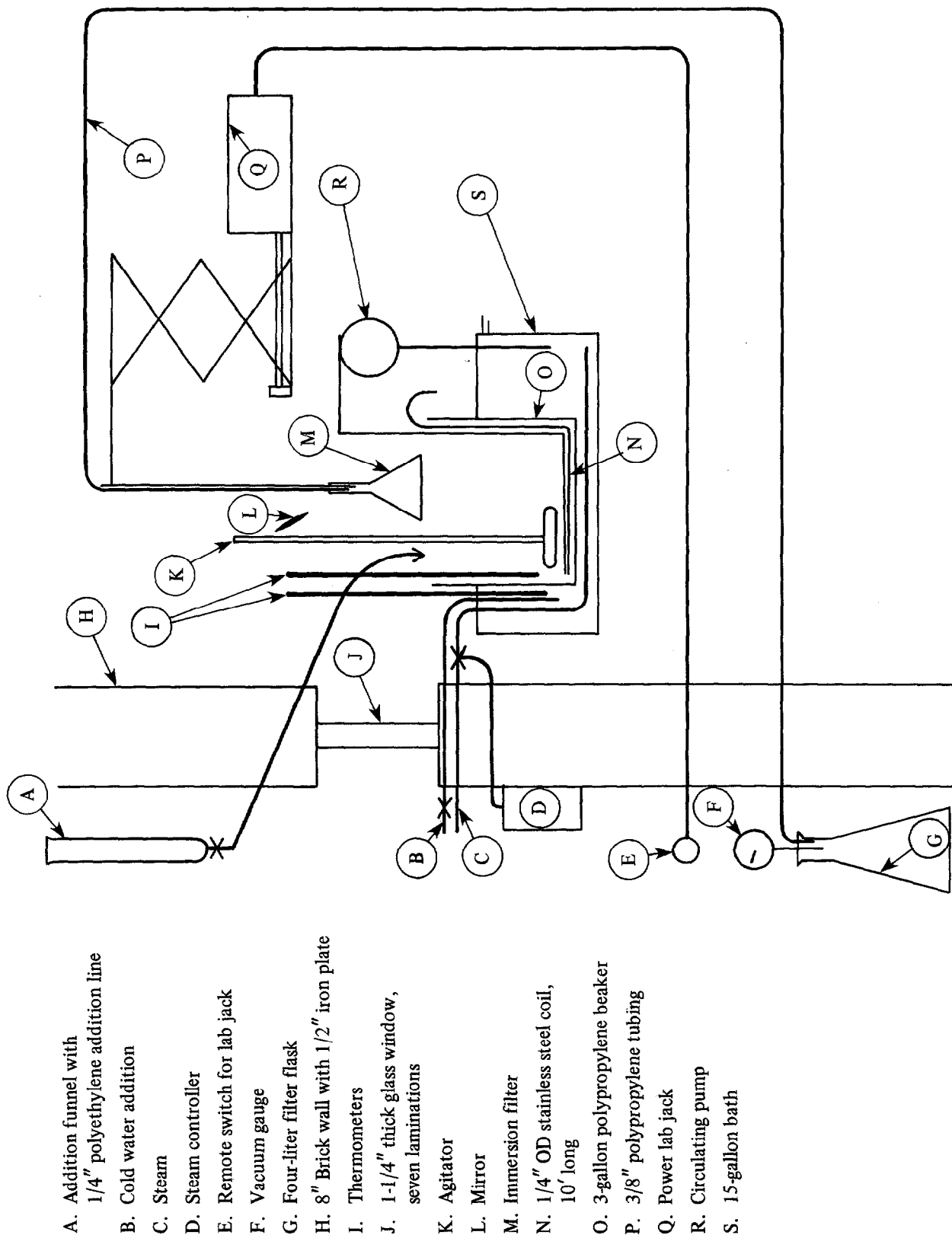
Fig 1 Equipment for Preparing $\text{Cuen}_2(\text{NT})_2$ and $\text{Hg}(\text{NT})_2$ (from Ref 8)

Fig 2 Hydraulic Transfer of Hg(NT)₂ (from Ref 8)

Table 9
Safety Data of Mercuric-5-Nitrotetrazole [Hg(NT)₂] and Its Intermediates^d (from Ref 8)

Material	Impact with 5kg Weight ^a (mm)	Sliding Friction ^b (lbs)	Electrostatic Discharge ^c (joules)
CuHNT(NT) ₂ ·4H ₂ O ^e , water wet	≥600 (low relat sensitivity)	≥980 (low relat sensitivity)	≥12.5 (low relat sensitivity)
CuHNT(NT) ₂ ·4H ₂ O, dry	50 (high relat sensitivity)	<40 (high relat sensitivity)	≥12.5 (low relat sensitivity)
Cu _{en} (NT) ₂ , dry	200 (medium relat sensitivity)	≥980 (low relat sensitivity)	≥12.5 (low relat sensitivity)
Hg(NT) ₂ , water wet	50 (high relat sensitivity)	<40 (high relat sensitivity)	≥12.5 (low relat sensitivity)
Hg(NT) ₂ , dry	50 (high relat sensitivity)	<40 (high relat sensitivity)	≥12.5 (low relat sensitivity)

Footnotes to Table 9:

- a—Three consecutive positive tests
b—8 ft/sec, 20 consecutive failures
c—5000 volts, 20 consecutive failures

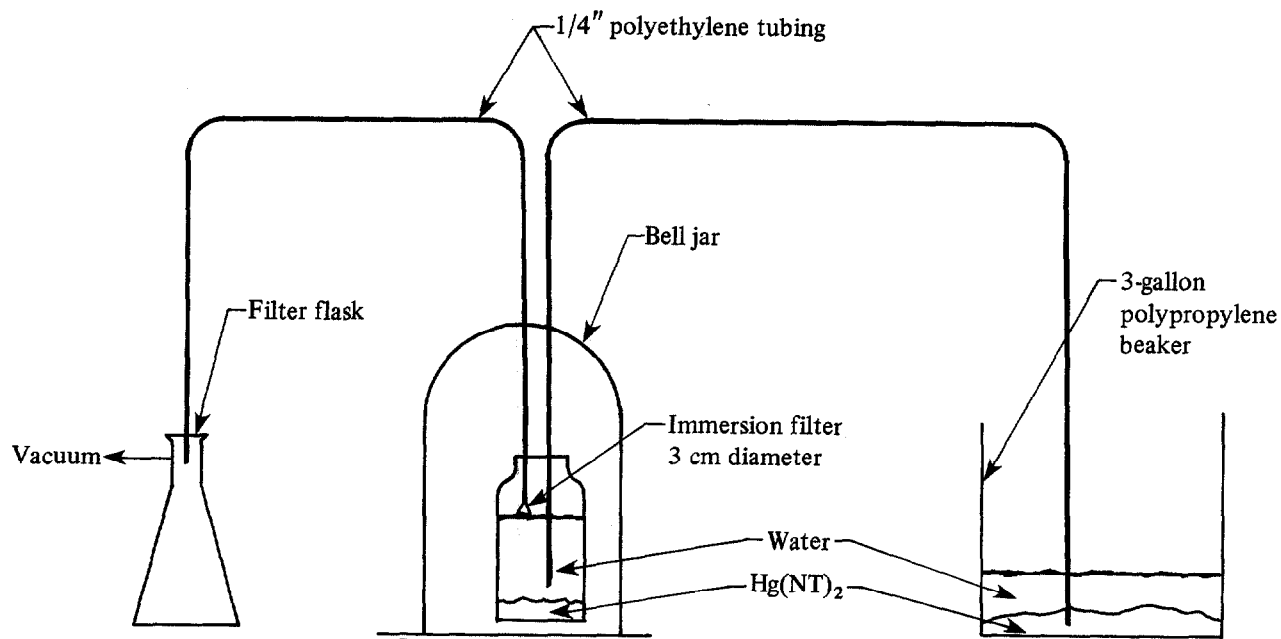
- d—Safety tests performed by NAVORDSTA Safety Department
e—Where NT is the acronym for the 5-nitrotetrazole radical

single component expl charge for an electric detonator used to initiate secondary expls. It is also claimed to be less sensitive to spark initiation than PbSt. The inventors report that when test-fired in a std electric detonator using 54mg charges, loaded at 10000psi, the ignition required 55–56 volts as compared to 56 volts for the std system. In the steel dent test, a detonator loaded with Hg-5-NT provides a dent of 21.8 mils compared to 16–19 mils with a conventional 3-component charge. The same inventors patented a stab-initiated compn contg Hg-5-NT (90–8) and tetracene (2–10 wt%) that they claim to be comparable in stab sensy and output to conventional 3-charge detonators (Ref 10)

1,1'-Cobalt-bis-5,5'-Nitrotetrazole.

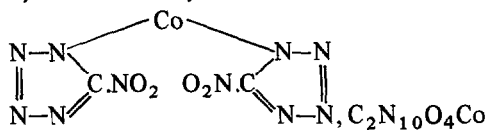
 $C_2N_{10}O_4Co$; mw 287.05; N 48.81%; OB to CO_2 is 0%; red-dish-white microscopic crystals; mp, detonates at 220° . V sl sol in w; not decompd by acids. Prepn is by treating aq NaNT with Co chloride. The salt is comparable in impact sensy to MF

1,1'-Nickel bis-5,5'-Nitrotetrazole. Mw 286.83; N 48.84%. Its prepn and properties are the same as the Co salt shown above

1,1'-Silver bis-5,5'-Nitrotetrazole.

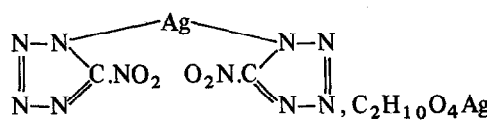
 $C_2H_{10}O_4Ag$; mw 235.99; N 59.37%; OB to CO_2 0%; white, felty ndles; mp, detonates at 230° . V v sl sol in w; insol in nitric acid. Prepn is usually by treating an aq soln of Na NT with an aq soln of Ag nitrate in the presence of an acid. A prepn patented by Bates and Jenkins (Ref 13) consists of forming an acid soln of a complex of $Cu(NT)_2$ with an aliphatic chelating amine, and then adding to the acid soln a soln of a soluble Ag salt to ppt the product. The Ag salt is slightly more sensitive than MF

Apart from the 5-NT salts shown above, there are two 5-NT derivatives of interest: 1-Methyl-5-NT and 2-Methyl-5-NT. These are

presented below:

1-Methyl-5-Nitrotetrazole (1-MNT).

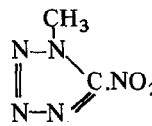
 $C_2H_3N_5O_2$; mw 129.10; N 54.26%; OB to CO_2 -43.38%; colorl cryst v sensitive to ultra-violet light; mp 52° ; d cast, is 1.775g/cc. Sol in eth and methylene chloride

Preparation, according to Ref 11, is as follows:

A mixt of 50g of aminotetrazole monohydrate, 19.1g of Na hydroxide, and 97ml of w is heated to $92-95^\circ$, and 31.7g of dimethyl sulfate is added dropwise over 40 mins. The temp of the reaction mixt is held at 96° for an additional hour and then cooled to 5° overnight. The product, 1-methyl-5-aminotetrazole, is removed by filtration, washed with cold w, and dried to yield 24.2g

A mixt of 5g of 1-methyl-5-aminotetrazole from above, 17ml of 96% sulfuric acid, and 300ml of w is added dropwise over 1 hr to a soln of 53g of Na nitrite in 500ml of w at 45° . The reaction mixt is stirred an additional hr at 45° and then cooled to 25° . The reaction is extracted with three 50-ml portions of methylene chloride. The methylene chloride extract is washed once with 5% Na bicarbonate and once with w. It is then dried over Mg sulfate and evapd, leaving 1.5g of yellow oil. This is combined with 6.0g of oil from another reaction, so as to have enough material for the next step, and dissolved in a minimum vol of diethyl ether. The ether soln is passed thru a neutral alumina column. The product from the column is then recrystd twice from ether to yield 3.5g of 1-methyl-5-nitrotetrazole. This compd is so light sensitive that it must be stored in methylene chloride soln at 0° in the dark

1-MNT can be used as a cast primary expl. In DDT expts conducted by Tarver et al (Ref 11) it was found that the threshold voltage for ignition by hot bridgewire (1-mil Nichrome of 4.5 to 7.5 ohms resistance) is 375 volts with a critical time of 8 microsecs and a critical distance of 2–3mm

2-Methyl-5-Nitrotetrazole (2-MNT).

$$\begin{array}{c} \text{H}_3\text{C.N-N} \\ | \quad \diagdown \\ \text{N=N} \quad \text{C.NO}_2 \end{array}$$
 $\text{C}_2\text{H}_3\text{N}_5\text{O}_2$; mw 129.10; N 54.26%; OB to CO_2 -43.38%; colorl cryst, v sensitive to ultra-violet light; mp 85° ; d, cast, is 1.67g/cc, 1.64g/cc (sep values). Sol in benz-petr eth mixt (10/3) and methylene chloride

Prepn according to Tarver et al (Ref 11) is as follows:

A mixt of 18g of Na 5-nitrotetrazole tetrahydrate, 400ml of w, 160ml of acet, and 20g of methyl iodide is refluxed for 3.5 hrs. More methyl iodide, 6g, is added after the first 2 hrs. The acet is then removed by distn, and 400ml of benz is added. The mixt is then washed with 100ml of 2% Na hydroxide in brine. After two addl washings with 25ml portions of brine, the soln is dried over Mg sulfate and evapd to dryness. The residue is then dissolved in a mixt of 200ml of benz and 60ml of petr eth and cooled to 0° for 24 hrs. The product is removed by filtration and dried under vac. Yield is 4.8g. The product, 2-methyl-5-nitrotetrazole, must be stored in methylene chloride soln at 0° in the dark

2-MNT can be used as a cast primary expl. In DDT expts conducted by Tarver et al (Ref 11), it was found that the threshold voltage for ignition by hot bridgewire (1-mil Nichrome of 4.5 to 7.5 ohms resistance) is 110 volts with a critical time of 8 microsecs and a critical distance of 2-3mm

Refs: 1) Beil, not found 2) E. vonHerz, GerP 562511 (1952) & CA, not found 3) E. vonHerz, USP 2066954 (1937) & CA 31, 1212 (1937) 4) J.P. Wintermayer, "... V. Preliminary Investigations on the Purification and Control of the Crystal Growth of Silver 5-Nitrotetrazole", NAVORD 2496 (1952) 4a) F.J. Taylor, NAVORD 2468 (1952) (Limited dist, not used) 5) J.M. Jenkins, ChemBrit 6, 401 (1970) 6) R. Shaw, "Structure-Property Correlations in Primary Explosives", SRI-TPR-74-2, Stanford Res Inst, Menlo Park, Contract N00017-73-C-4346 (1974) (AD A-026746) 7) C.L. Scott & H.S. Leopold, "Single Chemical Electric Detonator", USP 3965951 (1976) & CA 85, 110638 (1976) 8) R.E. Farncomb & M. Chang, "Process Scale-Up for Mercuric-5-Nitrotetrazole", NSW/WOL-TR-77-82, Dahlgren

& Silver Spring (1976) 9) W.H. Gilligan & M.J. Kamlet, "Synthesis of Mercuric 5-Nitrotetrazole", NSW/WOL/TR-76-146, Silver Spring (1976) 10) C.L. Scott & H.S. Leopold, "Stab-Initiated Explosive Device Containing a Single Explosive Charge", USP 4024818 (1977) & CA 87, 87254 (1977) 11) C.M. Tarver et al, "Structure/Property Correlations in Primary Explosives", SRI-FR-76-2, Stanford Res Inst, Menlo Park, Contract N00024-76-C-5329 (1976) (AD A-044714) 11a) W.H. Gilligan & M.J. Kamlet, "Improved Method of Preparing the Acid Copper Salt of 5-Nitrotetrazole", PatAppl 794197 (1977) (AD-D00-4164) 12) D.J. Glover, "Analysis of Mercuric 5-Nitrotetrazole", NSW/WOL/TR-77-71, Dahlgren & Silver Spring (1977) & CA 88, 123386 (1978) 13) L.R. Bates & J.M. Jenkins, "5-Nitrotetrazole Salts", USP 4094879 (1978) & CA 89, 163577 (1978)

1-(or N)-Oxytetrazole. See in Vol 8, O63-L

The Phenyl Tetrazoles and Derivatives

Phenylaminotetrazoles. See in Vol 1, A246-R to A249-L under "Aminophenyltetrazoles and Derivatives"

1-Phenyl-Tetrazole. See in Vol 8, P245-R

1-Phenyl-5-Mercapto-Tetrazole [1-Phenyl-tetrazolthion-(5) (Ger)].

$$\text{HS.C.N(C}_6\text{H}_5\text{).N}$$

$$\begin{array}{c} \parallel \quad \quad \parallel \\ \text{N} \text{-----} \text{N} \\ \diagdown \quad \diagup \\ \text{N} \quad \text{N} \end{array}$$
 $\text{C}_7\text{H}_6\text{N}_4$; mw 178.23; N 31.44%; white ndles; mp $152-56^\circ$ (can start decompn as low as 147°). V sol in hot ethanol, eth, chl, alkalis and alkali carbonates; sl sol in hot w; insol in cold w. Prepn is by reacting phenyl isothiocyanate with Na azide under reflux for 2 hrs. This compd forms the expl **5,5'-Lead-Bis-1,1'-Phenyl-5,5'-Mercapto Tetrazole.**

$$\begin{array}{c} \text{C}_6\text{H}_5 \quad \quad \text{C}_6\text{H}_5 \\ | \quad \quad \quad | \\ \text{N-N} \quad \quad \quad \text{N-N} \\ \diagdown \quad \diagup \quad \quad \quad \diagdown \quad \diagup \\ \text{N=N} \quad \text{C.S.Pb.S.C} \quad \text{N=N} \\ \diagup \quad \diagdown \quad \quad \quad \diagup \quad \diagdown \\ \text{N-N} \quad \quad \quad \text{N-N} \end{array}$$
 $\text{Pb(C}_7\text{H}_5\text{N}_4\text{S)}_2$; mw 561.64; N 19.96%; leaflets; mp, puffs off weakly at 224° . Prepn is by adding aq Pb acetate to Na-1-Phenyl-5-mercaptotetrazole

Refs: 1) Beil **26**, 409 & (124) 2) M. Freund & H. Hempel, Ber **28**, 78 (1895) 3) E. Oliveri-Mendala & F. Noto, Gazz **43**, I, 312 (1913) & CA **7**, 2934 (1914) 4) E. Oliveri-Mandalà, Ibid, **44**, I, 670 (1914) & CA **9**, 70 (1915) 5) R. Stollé, Ber **55**, 1289, 1295 (1922) & CA, not found 6) Ibid, JPraktChem **133**, 63 (1932) & CA **26**, 5565 (1932)

[1-(*p*-Nitrophenyl)]-Tetrazole. See in Vol **8**, P246-L

2-Phenyl-Tetrazole. See in Vol **8**, P246-L

[2-Phenyl-5-Methyl]-Tetrazole. See in Vol **8**, P247-L & R

5-Phenyl-Tetrazole. See in Vol **8**, P246-L & R

[5-(*m*-Nitrophenyl)]-Tetrazole. See in Vol **8**, P246-R

[1-Phenyl, 5-Azido]-Tetrazole. See in Vol **8**, P246-R

[2-Phenyl, 5-Carboxy]-Tetrazole. See in Vol **8**, P246-R to P247-L

[2-(*p*-Nitrophenyl), 5-Carboxyl]-Tetrazole. See in Vol **8**, P247-L

2,3-Diphenyl-Tetrazolyl-Oxide (?) [C-Oxy-diphenyl-tetrazolium-betain, Diphenylcarbodiazone or 2,3-Diphenyl-5-oxytetrazolium hydroxide (Ger)]

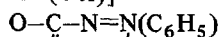

$\text{N}-\text{N}(\text{C}_6\text{H}_5)$, $\text{C}_{13}\text{H}_{10}\text{N}_4\text{O}$; mw 238.27; N 23.52%; OB to CO_2 -201.45%; lflts or ndles (from ethanol); mp, explds at 178–79°. Sol in ethanol, methanol and boiling w; insol in benz and eth. Prepn is by oxidn of N,N'-diphenyl-C-nitroformazan. Explds on impact. Diphenylcarbodiazone forms expl salts such as the **Picrate**; golden-yel lflts (from ethanol); mp 169°; explds above 169°; and the **Perchlorate**; colorl cryst; mp, explds at 194°

Refs: 1) Beil **26**, 408 & (124) 2) E. Bamberger, ChZtr **1898** II, 1050 3) P. Cazeneuve, CR **130**, 1562 (1900) 4) Ibid, **132**, 413 (1901) 5) E. Bamberger, Ber **44**, 3743–48

(1911) & CA **6**, 755 (1912) 6) E. Bamberger et al, Ann **446**, 262–63 (1926) & CA **20**, 1223 (1926)

2,3-Diphenyl-Tetrazolyl-Sulfide (?) [Diphenyl-tetrazolium-thio-betain; Diphenylthiocarbodiazone or 2,3-Diphenylmercaptotetrazolium hydroxide (Ger)]

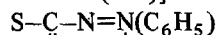

$\text{N}-\text{N}(\text{C}_6\text{H}_5)$, $\text{C}_{13}\text{H}_{10}\text{N}_4\text{S}$; mw 254.33; N22.03%; red ndles (from ethanol); mp, explds on heating without melting. Sol in hot ethanol, chl f and warm w; sl sol in benz and eth; insol in alkalis. Prepn is by heating N, N'-diphenyl-C-nitroformazan in the presence of isoamyl-nitrate

Refs: 1) Beil **26**, 409 2) E. Fischer & E. Besthorn, Ann **212**, 321 (1882) 3) E. Bamberger, Ber **44**, 3745 (1911) & CA **6**, 755 (1912) 4) E. Bamberger et al, Ann **441**, 282–82 (1926) & CA **20**, 1223 (1926)

5-Picrylamintetrazole. See in Vol **8**, P247-R

Pyrido-1',2':4,5-Tetrazole. See in Vol **8**, P247-R

[Phenyl]-[Phenyl-1-Tetrazolyl-5]-Triazene ([Phenyl, (1-phenyl tetrazolyl-5)]: I,III-triazene)

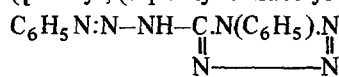

$\text{N}-\text{N}(\text{C}_6\text{H}_5)$, $\text{C}_{13}\text{H}_{11}\text{N}_7$; mw 265.40; N 36.95%; pale yel ndles; mp, explds weakly ca 130°. Sol in acet, benz and ethyl acetate; v v sl sol in eth and w. Prepn is by adding a soln of benzenediazonium chloride dropwise to an alc soln of 1-phenyl-5-aminotetrazole

Refs: 1) Beil, not found 2) R. Stollé, JPrakt-Chem **134**, 291–92 (1932) & CA **27**, 2687 (1933)

Semicarbazido-Tetrazole [1-(5-Tetrazolyl) Semicarbazide]



$\text{NH}-\text{N}(\text{C}_2\text{H}_5)_2$, $\text{C}_2\text{H}_5\text{N}_7\text{O}$, mw 143.14; N 68.51%; ndles (from w); mp 211° on slow heating, 218° on rapid heating. Sol in alkalis; insol in cold w. Prepn is by warming equimolar amts of 5-hydrazinotetrazole, K cyanate and HCl together. The compd forms an expl salt, **Sodium Semicarbazide-Tetrazole**;

Na.O.CO.N:N—C.N(Na).N
 $\begin{array}{c} \parallel \\ \text{N} \text{---} \text{N} \\ \parallel \\ \text{N} \end{array}$, C₂N₆O₂Na₂; mw
 186.06; N 45.18%; OB to CO₂ -17.20%; yel
 cryst; mp, explds on heating. Sol in w. Prepn is
 by treating the semicarbazide compd with K
 permanganate dissolved in aq K hydroxide, and
 then adding Na hydroxide

Refs: 1) Beil **26**, 407 2) J. Thiele & H. Ingle,
 Ann **287**, 237 (1895) 3) F.R. Benson, Chem-
 Revs **41**, 8 (1947) & CA **41**, 6885 (1947)

The Toly Tetrazoles

Aminotolytetrazoles and Derivatives. See in
 Vol 1, A165-R to A266-R

1,1'-Azo-5,5'-Di(p-Tolyl)-Tetrazole. See in Vol
 1, A266-R to A267-L

**(1'-o-Chlorophenyl-5-Amino-Tetrazolyl)-1-o-
 Chlorophenyl-5-Tetrazole** (or 1-o-Chlorophenyl-
 1-(o-chlorophenyl-5'-imino-1'-tetrazolyl)-5-tetra-
 zoldihydride-4,5).

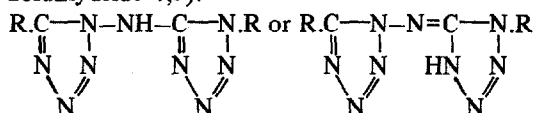

where R = O—Cl.C₆H₄; C₁₄H₈N₉Cl₂; mw
 373.22; N 33.79%; ndles (from ethanol); mp
 166° (decompn). Sol in hot ethanol. Prepn is
 by reaction of an ethanolic soln of di-o-chloro-
 benzhydrazide chloride with Na azide for 30 hrs
 at RT. The product is filtered off, washed with
 w and ether and hydrolyzed with dil sulfuric
 acid. The compd explds mildly when heated
 rapidly on a spatula

Refs: 1) Beil, not found 2) R. Stollé et al,
 JPraktChem **137**, 333 (1933) & CA **27**, 4233
 (1933)

5-(p-Tolyl)-Tetrazole [or p-Tolyltetrazotic
 acid (Ref 4)]

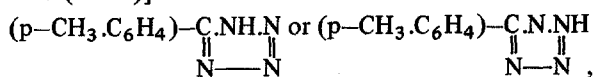

C₈H₈N₄; mw 160.20; N 34.98%; fine ndles (from
 ethanol); mp 248°. Sol in hot ethanol; v sl
 in ethanol; insol in w. Prepn is by heating an aq
 soln of 1-amino-5-p-phenyl tetrazole with Na

nitrite on a w bath in the presence of acetic acid.
 The product explds mildly on heating and forms
 expl salts such as **Silver-(p-Tolyl)-Tetrazole**;
 AgC₈H₇N₄; mw 266.96; N 20.99%; white solid.
 Sol in ammonia; insol in ethanol and w. Prepn is
 by treating Ag nitrate with neutral tolyltetra-
 zole (with Na bicarbonate). The Ag salt explds
 when heated above 250°

Refs: 1) Beil **26**, 365 2) A. Pinner & N. Caro,
 Ber **27**, 3278 (1894) 3) A. Pinner, Ann **298**,
 7-8 (1897) 4) W. Lossen & C. Kirschnick,
 Ann **298**, 105 (1897) 5) R. Stollé et al,
 JPraktChem **138**, 7 (1933) & CA **27**, 4798 (1933)

1'-p-Tolyl-5'-Tetrazolylamino-1-p-Tolyl-5-Tetrazole
 (or 1'-p-Tolyl-(5'-p-tolyl-1'-iminotetrazolyl)-5-
 tetrazoldihydride-4,5).

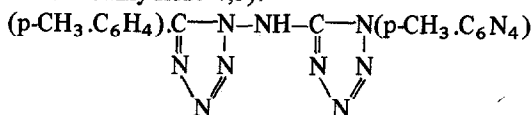

or

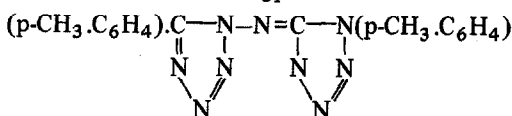

C₁₆H₁₅N₉; mw 333.40; N 37.82%; white ndles
 (from ethanol); mp 184°. V sol in Na bicarbon-
 ate soln; sol in ethanol and benz; sl sol in eth.
 Prepn is by reacting di-p-tolylhydrazide chlor-
 ide with an alc soln of Na azide for 20 hrs at
 RT. The Na salt of the compd, when reacted
 with a hot aq soln of Ag nitrate, forms the
 expl **Silver Salt**. Sol in dil aq ammonia; insol
 in ethanol and w. The salt explds mildly when
 heated rapidly on a porcelain spatula

Written by H. L. HERMAN

Refs: 1) Beil, not found 2) R. Stollé et al,
 JPraktChem **137**, 330-31 (1933) & CA **27**,
 4233 (1933)

Tetrazolines. There is some confusion in regard to this term. S. Ruhemann et al (Refs 2 & 3) called "Tetrazoline" the 6-membered ring compd:

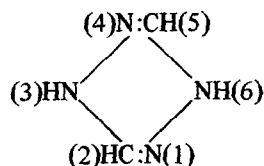

containing 2 C-atoms and 4 N-atoms (see also Vol 1, A268-R to A269-L under "4-Amino- γ -sym-triazole . . ."), while Beilstein calls a 5-membered ring compd containing 1 C-atom and 4 N-atoms, Δ^4 -Tetrazoline:

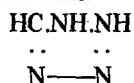

This is the preferred nomenclature. Comparing it with 5-tetrazole,

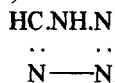

above Δ^4 -Tetrazoline may be called 2,3-dihydro-tetrazole

Some derivatives of tetrazoline are expl, for example:

(2-Carboxamide, 5-Nitroso)- Δ^4 -Tetrazoline
([2-Carboxamide, 3-hydro, 5-nitroso]-tetrazole; 5-Nitroso- Δ^4 tetrazolin-carbonsäure-(2)-amid (Ger) or C-Nitrosodihydro-tetrazol-N-carbonamid (Ger)). ON.C.NH.N(CO.NH₂);

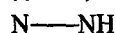

mw 120.10; N 58.33%; OB to CO₂ -53.29%; reddish-colored solid; mp, explds at 180-82°. Sol in alkalis, producing a reddish soln. Prepn is by treating N,N'-dicarboxamidinediazine (the "Hydrazin-N,N'-dicarbonsäure diamidin" of Beil 3, 120) with Na nitrite+HCl with strong cooling. The product is impure and explds violently on impact or rapid heating

Also, according to Ref 2, their "tetrazoline" forms an expl Ag salt, colorl ndles, by the reaction of tetrazoline with Ag nitrate

Refs: 1) Beil 26, 346 2) S. Ruhemann et al, JCS 75, 1131 (1899) 3) Ibid, 87, 1768 (1905) 4) H. Wieland & H. Bauer, Ber 40, 1685-86 (1907)

Tetrazotic Acid and Derivatives

The compd termed "Tetrazotic Acid", (CH₂)N₄, is known only thru its derivatives. Numerous org compds contg this nucleus; ie, one carbon and four nitrogen atoms linked in a chain, were prepd by Ger investigators beginning in the latter part of the 19th century. At first, any compd contg a chain of four nitrogen and one carbon atoms was called "Tetrazotsäure", but later it was shown that some of these compds have open chain linkages, such as:

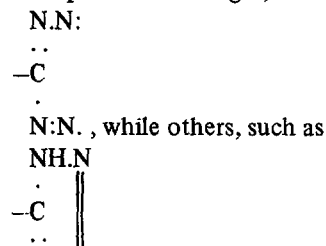

consist of a closed ring. In order to avoid confusion, the derivatives of the first (open chain) compd are now called "Tetrazotic Acids", while derivatives of the second (closed ring) comp are called "Tetrazoles". There were, however, some investigators, who as late as 1922 (for instance, Rathsburg, see Ref 3) called compds which are considered to have an open chain structure "tetrazoles", instead of calling them "tetrazotic acids" as Beilstein does. Five such compds are listed in Ref 3; benzenyl-dioxy-tetrazole, m-nitro-benzenyl-dioxy-tetrazole, phenylethenyl-dioxy-tetrazole, phenyl-glycolenyl-dioxy-tetrazole and p-tolenyl-dioxy-tetrazole

All of the compds mentioned by Rathsburg were prepd by Lossen et al at the end of the 19th century and were considered as derivatives of "dioxytetrazotsäure",

$\begin{array}{c} \text{HC} \text{---} \text{N.N:O} \\ \quad \quad \quad \backslash \\ \quad \quad \quad \text{N:N.OH;} \end{array}$ which should correspond in English to oxy, hydroxy-tetrazotic acid

If we take, for example, the compd to which Beilstein assigned the structural formula,

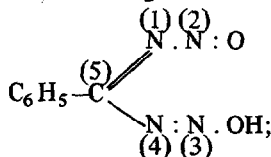

then it will be clear that Rathsburg's name,

“benzenyldioxytetrazole” is a very bad misnomer. However, Lossen’s name for it, “benzenyldioxytetrazotsäure”, is also a misnomer and should really be, in English, **oxy, hydroxy, phenyl-tetrazotic acid**

In order to show the location of O, OH and C₆H₅ groups, let us assign Roman numerals, I, II, III, IV and V to one carbon and to each of the four nitrogens of the tetrazotic acid chain. This is in order to distinguish them from ring compds – “Tetrazoles” -- (which have Arabic numerals), and to be comparable to other open chain compds with several nitrogens, such as triazenes, tetrazenes, etc (which also have Roman numerals)

If this system were adopted, then the name for “benzenyldioxytetrazotsäure” would be **(II-oxy, III-hydroxy, V-phenyl)-tetrazotic acid**

There are compds, however, which are still called “tetrazotsäure” by some investigators, although it has been now definitely established that they are derivatives of ring compds – “tetrazoles”. For example, the compd prepd by Lossen et al, and called “benzenyltetrazotsäure”, is in reality 5-phenyl-tetrazole (see in Vol 8, P246-L & R)

Refs: 1) Beil 9, 331, 332, 388, 447, 496 and 661; 10, 209–10; 26, 447–97 2) W. Lossen, C. Lossen et al, Ann 263, 73–108 (1890); Ann 297, 332–53 (1897); Ann 298, 54–116 (1897) 3) H. Rathsburg, BritP 185555 (1922) & CA 17, 1147 (1923)

Derivatives of Tetrazotic Acids. The following expl compds are listed in Beilstein 9 and 10 as derivatives of open chain compds, called by him “dioxytetrazotsäure” and “oxytetrazotsäure”:

Amidotetrazotsäure. Old Ger name for 5-Aminotetrazole. See in Vol 1, A258-L to A259-R under “5-Amino- α -Tetrazole . . .”

Aminotetrazotic Acid. Another old name for 5-Aminotetrazole

Benzenyldioxytetrazotic Acid [(IIN-Oxy, IIN-hydroxy, VC-phenyl)-tetrazotic acid; called by Lossen (Refs 2 & 3), “Benzenyldioxytetrazotsäure” and by Rathsburg (Ref 4), “Benzenyldioxytetrazole”]

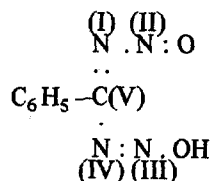

mw 178.15; N 31.45%; OB to CO₂ –134.72%; dk violet-brn cryst; mp, expl on decompn without melting. Sol in w. May be prepd by treating the K salt of “benzenyldioxytetrazotic acid” with sulfuric acid at 0°. The product is then extracted with amyl alc. The K salt is prepd by treating benzamidine hydrochloride with K nitrite and nitric acid (Refs 2 & 3). The free acid is sol in w. However, its aq soln is very unstable, decompn on standing into benzonitrile, nitric acid, NO and N₂ (Ref 3, pp 341–48)

Benzenyldioxytetrazotic acid forms expl salts and addition compds, such as:

Aniline compd. C₇H₆O₂N₄+C₆H₇N; mw 271.31; N 25.8%; OB to CO₂ –179.87%; white ndles. Sol in ethanol; diff sol in w; insol in eth. Puffs off at 93° with formation of a large amt of smoke

Hydrazine addition compd. (C₇H₆O₂N₄)₂+ N₂H₄; mw 388.40; N 36.1%; OB to CO₂ –135.94%; plates. Sol in ethanol and w; insol in eth. Explds violently at 60° or when rubbed in a mortar

Potassium salt. KC₇H₅O₂N₄; mw 216.26; N 25.91%; OB to CO₂ –107.28%; ndles or leaflets. Sol in w and ethanol. Explds on heating, impact or contact with sulfuric acid

Silver salt. AgC₇H₅O₂N₄; mw 177.16; N 19.6%; OB to CO₂ –130.96%; white solid. Very expl

Rathsburg proposed using the salts and derivatives of benzenyldioxytetrazotic acid in detonators and percussion caps

Refs: 1) Beil 9, 331 2) W. Lossen & F. Mierau, Ann 263, 81–87 (1890) 3) W. Lossen & M. Groneberg, Ann 297, 325–49 (1897) 4) H. Rathsburg, BritP 185555 (1922) & CA 17, 1147 (1923) 5) Hack’s Chem Dict (1972), 670

Benzenyloxytetrazotic Acid. [(IIN-Oxy, IIN-hydro, VC-phenyl)-tetrazotic acid or Benzenyloxytetrazotsäure (Ger)]

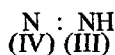
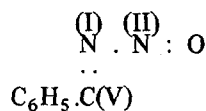

mw 162.15; N 34.56%; OB to CO₂ -157.88%;
cryst; mp 175° (decompn). It crystallizes in
the anhydr state from acetic acid and as a mono-
hydrate from ethanol plus eth. Benzenyloxy-
tetrazotic acid is sol in acetic acid, eth plus
ethanol mixt, and in sl warm concd sulfuric
acid (in which it may be heated to 130° without
decompn)

It is stable towards alkalies and reducing
agents

It forms expl salts, such as:

Barium salt. Ba(C₇H₅ON₄)₂+3H₂O; mw 322.32;
N 34.77%; OB to CO₂ -153.88%; leaflets. Sol
in w and ethanol. Loses w of crystn at 105°
and puffs off when heated on Pt foil

Copper salt. Cu(C₇H₅ON₄)₂+3H₂O; mw 385.87;
N 25.5%; OB to CO₂ -128.54%; grn ndles. The
salt explds

Lead salt. An expl

Benzenyloxytetrazotic acid also forms expl
esters such as:

Ethylester [Benzenyloxytetrazotsäure-äthylester
(Ger)]. C₇H₅N₄O.C₂H₅; mw 190.23; N 29.5%;
OB to CO₂ -185.04%; yel oil. Prepn is from
Ag benzenyloxytetrazotate, eth and ethyl
iodide. The ester explds on heating

Methylester [Benzenyloxytetrazotsäure-methyl-
ester (Ger)]. C₇H₅N₄O.CH₃; mw 176.20; N
31.8%; OB to CO₂ -172.53%; mp 40°. Prepn
is from Ag benzenyloxytetrazotate, eth and
methyl iodide. Explds on heating above its mp

Mononitromethylester [Nitrobenzenyloxyte-
trazotsäure-methylester (Ger)]. C₇H₄(NO₂)-
N₄O.CH₃; mw 221.20; N 31.7%; OB to CO₂
-119.35%; ndles from ethanol; mp 112°. Prepn
is by treating the methylester with nitric acid
(d 1.53g/cc) in the cold. Insol in w, acids and
alkalies; sol in eth and warm ethanol. Explds
when heated on a Pt foil

Refs: 1) Beil **9**, 332 2) W. Lossen & C.

Lossen, Ann **263**, 97-110 (1890) 3) W.

Lossen & M. Groneberg, Ann **297**, 348 (1897)

4) W. Lossen & F. Fuchs, Ann **298**, 54-67
(1897)

β-Naphthenyldioxytetrazotic Acid [(IIN-Oxy,
IIN-hydroxy, VC (β-naphth)]-tetrazotic acid,
erroneously called by Rathsburg, "β-Naphthenyl-
dioxytetrazole", or "β-Naphthenyldioxytetrazot-
säure" (Ger)).

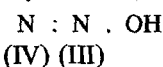
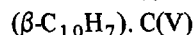

mw 228.21; N 24.55%. Only its derivatives and
salts have been reported

Lossen and Bogdahn (Ref 2) prepd the
following adduct in 1897, which they called
**β-Naphthenyldioxytetrazotsäure-β-Naphthenyl-
amidin**. C₁₁H₈O₂N₄+C₁₁H₁₀N₂; mw 398.46;
N 21.1%; OB to CO₂ -204.79%; ndles from
ethanol; mp, puffs off at about 180°. Sol in
hot ethanol; sl sol in w and cold ethanol; nearly
insol in eth. Prepn is by reacting a soln consist-
ing of 2 moles of K nitrite in 1 mole of concd
sulfuric acid with an aq soln of 1 mole of β-
naphthenylamidine at RT. After allowing the
mixt to stand, the crystals of the double salt are
sepd by filtration

By treating the above-mentioned adduct with
alc KOH, the **Potassium Salt of β-Naphthenyl-
dioxytetrazotic Acid**, KC₁₁H₇O₂N₄; mw
266.32; N 21.04%; OB to CO₂ -141.18% is
obtd. Yellowish ndles, which expld violently.
Sol in w

The **Silver salt**, AgC₁₁H₇O₂N₄; mw 335.09;
N 16.72%; OB to CO₂ -112.45%; white ppt,
turning violet in the light; is also an expl

Rathsburg (Ref 3) patented the use of salts
and derivatives of β-Naphthenyldioxytetrazotic
acid in detonators and percussion caps

Refs: 1) Beil **9**, 659 & 661 2) W. Lossen &
F. Bogdahn, Ann **297**, 380-86 (1897) 3) H.
Rathsburg, BritP 185555 (1922) & CA **17**,
1147 (1923)

m-Nitrobenzenyldioxytetrazotic Acid [(II Oxy,
III hydroxy, (V-m-nitrophenyl)]-tetrazotic Acid,
called by Rathsburg (Ref 3) "m-Nitro-benzenyl-
dioxy-tetrazole", "3-Nitrobenzenyldioxytetrazot-
säure" (Ger) or "Metanitrobenzenyldioxytetra-
zotsäure" (Ger)).

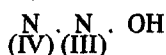
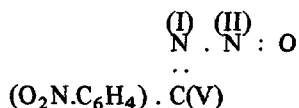

mw 223.15; N 31.39%. This compd is very unstable; it is known in the form of its adducts and salts, most of which are expl:

Barium salt. $\text{Ba}(\text{C}_7\text{H}_4\text{O}_4\text{N}_5)_2$; mw 561.66; N 24.94%; OB to CO_2 -68.37%. Nearly insol in w and ethanol. Explds on heating with a "crack" and the appearance of a green flame

m-Nitrobenzamidinium adduct, $\text{C}_7\text{H}_5\text{O}_4\text{N}_5 + \text{C}_7\text{H}_7\text{O}_2\text{N}_3$; mw 388.34; N 28.9%; OB to CO_2 -115.36%; yel cryst; mp 176° (decompn). Insol in common solvents. Prepn is by treating m-nitrobenzamidinium with K nitrite. Explds violently when heated above mp

Potassium salt. $\text{KC}_7\text{H}_4\text{O}_4\text{N}_5$; mw 261.26; N 26.8%; OB to CO_2 -73.49%; ndles. V sl sol in cold w and ethanol. Prepn is the same as the preceding adduct. Explds violently on heating, impact or friction

Silver salt. $\text{AgC}_7\text{H}_4\text{O}_4\text{N}_5$; mw 349.62; N 20.04%; OB to CO_2 -54.92%; solid. Explds violently

Rathsburg (Ref 3) suggested the use of the Acid's salts and derivatives in detonators and percussion caps

Refs: 1) Beil 9, 388 2) W. Lossen & N. Neubert, Ann 263, 88-92 (1899) 3) H. Rathsburg, BritP 185555 (1922) & CA 17, 1147 (1923)

"Phenethenyldioxytetrazotic Acid" [(IIN-Oxy, IIN-hydroxy, VC-benzyl)-tetrazotic acid, erroneously called by Rathsburg (Ref 4), "Phenyl-ethenyl-dioxy-tetrazol" or "Phenäthyndioxy-tetrazotsäure" (Ger)].

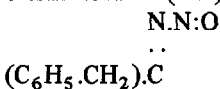

N:N.OH; mw 192.18; N 29.16%.

Reported only in the form of its salts and derivatives, some of them being expl:

Potassium salt. $\text{KC}_8\text{H}_7\text{O}_2\text{N}_4$; mw 230.29; N 24.33%; OB to CO_2 -121.59%; leaflets from ethanol. Sol in w; sl sol in ethanol; insol in eth. Prepn is by treating the adduct of phenethenyl-

dioxytetrazotic acid + phenacetamidine with alc KOH. The salt explds violently on heating, impact or friction

Silver salt. $\text{AgC}_8\text{H}_7\text{O}_2\text{N}_4$; mw 299.09; N 18.74%; OB to CO_2 -93.62%. Prepn is by treating a soln of the corresponding K salt with Ag nitrate. The salt is extremely expl

Rathsburg (Ref 4) patented the use of phenethenyldioxytetrazotic acid salts and derivatives in detonators and percussion caps

Refs: 1) Beil 9, 447 2) W. Lossen & C. Lossen, Ann 263, 92-95 (1890) 3) W. Lossen & E. Kammer, Ann 298, 79-80 (1897) 4) H. Rathsburg, BritP 185555 (1922) & CA 17, 1147 (1923)

Phenethenyloxytetrazotic Acid [(IIN-Oxy, IIN-hydro, VC-benzyl)-tetrazotic acid or Phen-athenyloxytetrazotsäure (Ger)]

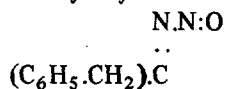

N:NH; mw 176.20; N 31.8%; OB to CO_2 -172.53%; yellowish ndles; mp 135° ; bp (puffs off). V sol in ethanol; sol in eth; v sl sol in cold w; fairly sol in hot w (without decompn). Prepn is by treating a 1% soln of the K salt of phenethenyldioxytetrazotic acid with 10% Na amalgam, and then acidifying the mixt with HCl (Ref 2). The acid explds on heating above its mp. It forms an expl derivative, the **Methylether**; $\text{C}_8\text{H}_7\text{N}_4\text{O}\cdot\text{CH}_3$; mw 190.23; N 29.5%; OB to CO_2 -185.04%; yel oil. Prepn is by treating the Ag salt of $\text{C}_8\text{H}_8\text{ON}_4$ with methyl iodide. The ether is a very expl compd

Refs: 1) Beil 26, 447 2) W. Lossen & E. Kammer, Ann 298, 78-88 (1897)

i-Phenylglycolenyldioxytetrazotic Acid (*i*-[IIN-Oxy, IIN-hydroxy, VC-hydroxyphenylmethyl]-tetrazotic acid, erroneously called by Rathsburg, (Ref 3) "Phenylglycolenyldioxytetrazole" or "Inakt Phenylglykolenyldioxytetrazotsäure" (Ger)].

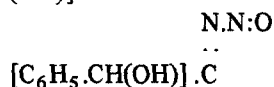

N:N.OH; mw 208.18; N 26.92%. Only its derivatives are described in

the literature. Its **Phenylglycoleneamidine salt** (or Mandelic acid amidine salt) is an expl; $C_8H_8O_3N_4 + C_6H_5.CH(OH).C(:NH).NH_2$; mw 358.40; N 23.5%; OB to CO_2 -165.18%; mp, expls. Prepn is by allowing an aq soln of 1 mole of the inactive hydrochloride of mandelic acid amidine to stand for 24 hrs at 30° , and then adding 4 moles of K nitrite and 1 mole of nitric acid. By treating this salt with an equimolecular quantity of alc KOH, one obtains, the **Potassium salt of i-Phenylglycolenyldioxytetrazotic Acid**, $KC_8H_7O_3N_4$; mw 207.14; N 27.05%; OB to CO_2 -127.42%; white powder. Sol in w (18g/100ml at 17°). Expls violently on heating, impact, friction or when brought into contact with concd sulfuric acid. The K salt is used as the starting material for the prepn of other salts such as the:

Barium salt. $Ba(C_8H_7O_3N_4)_2$; mw 414.38; N 27.05%; OB to CO_2 -127.42%; white cryst. Insol in w. This salt is less expl than the K salt
Silver salt. $AgC_8H_7O_3N_4$; mw 315.06; N 17.79%; OB to CO_2 -83.79%; white voluminous mass which darkens by the action of light. A very sensitive compd, expldg even when still wet

Rathsburg's patent suggested the use of the salts of "i-Phenylglycolenyldioxytetrazotic Acid" in detonators and percussion caps
Refs: 1) Beil **10**, 209-10 2) W. Lossen & F. Bogdahn, Ann **297**, 371-80 (1897) 3) H. Rathsburg, BritP 185555 (1922) & CA **17**, 1147 (1923)

p-Tolenyldioxytetrazotic Acid ([IIN-Oxy, IIIN-hydroxy, VC-(p-tolyl)]-tetrazotic acid, erroneously called by Rathsburg (Ref 3), "p-Tolenyldioxytetrazole" or "p-Tolenyldioxytetrazot-säure" (Ger)).

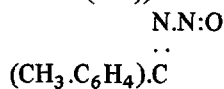

N:N.OH; mw 192.18; N 29.16%.

Only its salts and derivatives have been described in the literature, some of which are expl:

Barium salt. White solid; nearly insol in w; an expl

Potassium salt. $KC_8H_7N_4O_2 + H_2O$; mw 248.31; N 22.57%; OB to CO_2 -112.7%; long ndles or leaflets from w; mp, loses w and expls. Sol in w (2.4% at RT) and ethanol; insol in eth. Prepn

is by treating an aq soln of the p-tolenylamidine salt (see below) with an equimolecular quantity of alc KOH, and filtering off the product. The K salt expls violently on heating and even sometimes at RT while partly wet. It must be stored as an aq soln. The HCl hydrolysis product, a dark-grn ppt, expls spontaneously

"Rubamidid" compd,
NH₂

$(\text{CH}_3.C_6H_4).C$
..
N.N:O; $C_8H_9ON_3$; mw 163.20; N 25.8%; OB to CO_2 -191.18%; red amorph ppt; mp, expls at $60-65^\circ$. Insol in eth and w; sol in ethanol. Prepn is by shaking the K salt of p-Tolenyldioxytetrazotic acid for 5 mins with an equimolecular amt of one normal HCl and, after filtering, treating the ppt with ammonia
Silver salt. White amorph solid; nearly insol in w; expls on heating

p-Tolenylamidine salt. $C_8H_8O_2N_4 + CH_3.C_6H_4.C(:NH).NH_2$; mw 326.40; N 25.8%; OB to CO_2 -191.18%; leaflets from w, cubic or prismatic cryst from ethanol; mp, puffs off at $195-98^\circ$. V sl sol in ethanol and w; not sol in benz and eth. Prepn is by adding 20ml of HCl (d=1.2g/cc) dropwise to a mixt of the hydrochloride of p-tolenylamidine (20g in 100cc w) and K nitrite (80g in 80cc w) and then warming the mixt at 60° . The salt expls on heating

Rathsburg's patent suggests the use of the salts and the derivatives of p-Tolenyldioxytetrazotic acid as primary charges in detonators and percussion caps
Refs: 1) Beil **9**, 496-97 2) W. Lossen et al, Ann **397**, 349-70 (1897) 3) H. Rathsburg, BritP 185555 (1922) & CA **17**, 1147 (1923)

p-Tolenyloxytetrazotic Acid ([IIN-Oxy, IIIN-hydro, VC (p-tolyl)]-tetrazotic acid or p-Tolenyloxytetrazotsäure in Ger).

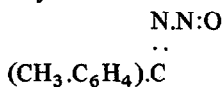

N:NH.H₂O; mw 194.22; N 28.85%; OB to CO_2 -164.76%; prisms from ethanol and eth; mp, loses w in an atm of CO_2 ca 120° and melts with decompn at about 172° . Easily sol in ethanol; sol in eth and hot w; diff sol in cold w. Prepn is by allowing an aq soln of the K salt of

p-tolenyldioxytetrazotic acid to stand for 12 hrs with 10% Na amalgam. The monohydrate detonates when heated rapidly to 184.4° and puffs off ca 172°

p-Tolenyloxytetrazotic acid forms several salts, some of which might prove to be expl. However, Lossen et al, who prepd these salts, failed to examine their explosibility

Refs: 1) Beil 9, 497 2) W. Lossen & P. Schneider, Ann 298, 67-68 (1897)

Tetraazylazide and its Salts

Tetraazyl Azide (Tetraazyl Azide, 5-Azido-Tetrazole, Tetraazyl Azide).

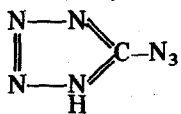

CHN₇; mw 111.09; N 88.28%;
OB to CO₂ -36.01%; colorl
needles from benz. V sol in
acet and w; sl sol in benz; insol

in ligr and eth

Can be prepd by reacting 5-hydrazinoltetrazole with Na nitrite and hydrochloric acid at 0°; from cyanogen bromide and Na azide in w (Ref 4); or from the Cu salt of 1-guanyl-4-nitrosaminoguanyltetrazene on treatment with acid (Ref 6a)

Tetraazyl azide is extremely sensitive, expldgd with brisance on heating or rubbing. Five inorg expl salts are described below:

Ammonium Tetraazyl Azide. NH₄CN₇; mw 128.13; N 87.47%; OB to CO₂ -49.95%; powdered dust. V sol in methanol and w; sparingly sol in benz and ethanol. Prepn is by heating Tetraazyl Azide with concd amm hydrazoate.

The salt deflagrates on heating

Barium Tetraazyl Azide. Ba(CN₇)₂; mw 357.50; N 54.86%; OB to CO₂ -17.70%. Sol in acet, pyr and w; v sl sol in eth, ethanol, carbon disulfide, carbon tetrachloride, trichloroethylene, benz, chl and petr eth. Prepn is by reacting Ba cyanogen with Na azide. The Ba salt deflagrates violently when heated, and has an impact sensy of 70cm using a 500g wt

Lead Tetraazyl Azide. Pb(CN₇)₂; v sl sol in acet, eth, ethanol, w and most org solvents. Prepn is by addn of a Pb nitrate soln to an aq soln of Tetraazyl Azide. The salt explds on heating, and has an impact sensy of 100cm with a 5kg wt

Silver Tetraazyl Azide. AgCN₇; mw 217.95; N

45.0%; OB to CO₂ -14.68%; scales. Not sol in cold dil nitric acid. A possible prepn is the reaction of Ag azide with Br cyanogen. A very unstable and brisant expl which can deton on warming in w, or simply standing at RT
Sodium Tetraazyl Azide. NaCN₇; mw 133.07; N 73.70%; OB to CO₂ -24.05%; white powder. V sol in w. Prepn is by reaction of Na azide with Br cyanogen at RT. When dry the salt bursts into flame; it is also impact sensitive

The prepn of organic tetraazyl azides is accomplished by reaction of the azides' alkali or alkaline earth salts with organic chlorides, sulfates or nitrocompds in suitable solvent media. The compds so formed are reported to be remarkably stable and brisant expls. It is suggested in the referenced patents that these tetraazyl azides be used either alone or in combination with inert materials such as powdered glass, kieselguhr, Sb sulfide, etc, or other expls to form initiating or HE compns. Examples of organic tetraazyl azides are: **Acetone Mono- or Di-Tetraazylazide** (a solid); **Ethylene Di-Tetraazylazide** (v brisant; easily ignited); **Methyl Tetraazylazide** (a solid); **Picryl Tetraazylazide** [(NO₂)₃-C₆H₂.CN₇; a solid less easily ignited than the others; suitable for use in detonators or fuses]; and **Trinitrophenylamino Tetraazylazide** [(NO₂)₃-C₆H₂.NH.CN₇; a solid; prepn by reaction of tetranitroaniline with an alkali tetraazyl azide]
Refs: 1) Beil 26, 347, (110) & [197 & 366] 2) W. Friederich, USP 2170943 (1939) & CA 34, 265 (1940) 3) Ibid, FrP 841768 (1939) & CA 34, 4574 (1940) 4) W. Friederich & K. Flick, USP 2179783 (1939) & CA 34, 1827 (1940) 5) W. Friederich, GerP 695254 (1940) & CA 35, 5318 (1941) 6) Ibid, BritP 519069 (1940) & CA 35, 7982 (1941) 6a) Blatt, OSRD 2014 (1944) 7) H. Ficherouille & A. Kovache, "Salts of Tetraazyl Azide", MP 41, 9-11 (1957)

Tetraazylazoimide and Salts. See in Vol 1, A659-R to A660-L under "Azotetrazole"

Tétréthyl or Ethyl Tetryl. See in Vol 6, E207-L

Tetritol. Russ for Tetryl. See under "Russian Explosives and Related Items" in this Vol

Tetrytol-Cyclonite. Russ for Tetryl/TNT/RDX 11.7/16.4/71.9. See under "Tetrytol-Cyclonite Explosive" in "Russian Explosives and Related Items" in this Vol

Tetrytols. The 1,2,3,4-tetrahydroxybutenes. These include the sugar alcohols erythritol and DL-erythritol which can be nitrated to stable expls. See in Vol 5, E123-L to E125-L under "Erythritol . . . (thru) . . . Erythritol Tetranitrate (ErTeN) . . ." and in this Vol under "Sugar Alcohols and Their Nitrated Derivatives"

Refs: 1) M.L. Wolfrom, "The Tetrytols and Their Nitrates", Interim Rept, Ohio State Univ, Contract DA-33-019 ord 163 (1951)

2) Ibid, Final Report (1952) 3) J.A. Monick, "Alcohols . . .", Reinhold, NY (1968), 415-22

Tetroxyl. Trinitrophenylmethoxynitramine (USA)

Tetryl (2,4,6-Trinitrophenylmethylnitramine, N-2,4,6-tetranitro-N-methyl aniline, or picrylmethylnitramine, also called Pyronite, Tetrylit, Tetralite or Tetralita)

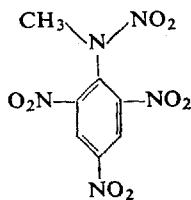

mw 287.0; N 24.4%; OB to CO₂ -47%; a pale yellow to yellow solid of 1.73g/cc theoretical max d (TMD) and 1.71g/cc nominal d; mp 130°C pure, 129°C technical grade

I. History and Uses

Tetryl was first prepd in 1877 by Mertens, who reacted fuming nitric acid with a sulfuric acid soln of dimethylaniline (Ref 1). He also obtd Tetryl by boiling a soln of dinitrodimethylaniline in fuming nitric acid. The structure of

Tetryl was established by Romburgh (Ref 2) by synthesizing it from K methylnitramine and picryl chloride:

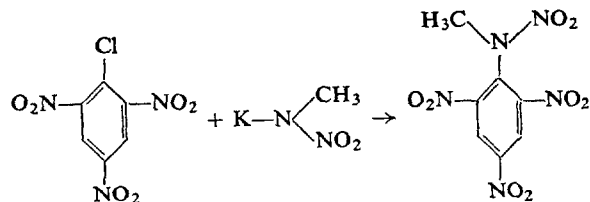

Tetryl has been used as an expl since 1906. In the early part of this century it was frequently used as the base charge of blasting caps but is now replaced by PETN or RDX. During WWII it was used as a component of expl mixts (see "Tetrytols" in this Vol). Tetryl is still used in military boosters and leads (the expl component of a fuze between the detonator and booster), but even here it is being replaced by plastic-bonded or waxed RDX and HMX expls. A widely used shock sensitivity test employs Tetryl as the donor charge (see "Shock Sensitivity of Explosives" in this Vol)

II. Physical Properties

Crystal & Optical data: monoclinic crystals with unit cell dimensions of a) 14.13Å, b) 7.37Å, and c) 10.61Å (Ref 34a); refractive index α) 1.546, β) 1.632, γ) 1.74 (calc) (Ref 34a)

Density ρ :	Loading pressure (psi)	Density (Ref 46a) (g/cc)
	0	0.9
	3	1.40
	5	1.47
	10	1.57
	12	1.60
	15	1.63
	20	1.67
	20	1.71
	cast	1.62

Solubility (Ref 46a):

Solubility of Tetryl, grams in 100 grams (%) of:

°C	%	
	Water	
0		0.0050
20		0.0075
40		0.0110
80		0.0810
100		0.184

<u>°C</u>	<u>%</u>
<u>Carbon tetrachloride</u>	
0	0.007
20	0.015
40	0.058
60	0.154
<u>Ether</u>	
0	0.188
10	0.330
20	0.418
30	0.493
<u>95% Alcohol</u>	
0	0.320
10	0.425
20	0.563
30	0.76
50	1.72
75	5.33
<u>Chloroform</u>	
0	0.28
20	0.39
40	1.20
60	2.65
<u>Carbon disulfide</u>	
0	0.009
10	0.015
20	0.021
30	0.030
<u>Ethylene dichloride</u>	
25	4.5
75	45
<u>Acetone</u>	
20	75
30	95
40	116
50	138
<u>Trichloroethylene</u>	
0	0.07
20	0.12
40	0.26
60	0.67
80	1.50
86	1.76

<u>Ethyl acetate</u>	
20	~40
<u>Benzene</u>	
20	7.8
30	10.0
40	12.5
50	16.0
<u>Toluene</u>	
20	8.5
<u>Xylene</u>	
20	3.3
30	4.4
40	5.4
50	6.0
<u>TNT</u>	
80	82
100	149
120	645

Dissolves readily in concd nitric acid, moderately in other mineral acids, and barely (0.3%) in spent acid (Ref 34)

Dielectric Constant ϵ (Ref 57):

ρ (g/cc)	0.9	1.0	1.4	1.5	1.6	1.7
ϵ (measured at 35GHz)	2.059	2.163	2.782	2.905	3.097	3.304

Dielectric Strength: Increases with increasing ρ and decreasing electrical pulse width; values range from 13 to 25kV/mm (Ref 47a)

Thermal Characteristics:

Standard heat of formation (ΔH_f°)

+4.67 Kcal/mole (Ref 57)

+7 \pm 1 Kcal/mole (Ref 54)

Heat of fusion

+6.3 Kcal/mole (Ref 46)

+5.48 Kcal/mole (Ref 54)

Standard entropy of fusion – 13.7 eu (Ref 57)

Heat of vaporization – 26 Kcal/mole (Ref 11)

Thermal Conductivity: 6.83×10^{-4} cgs units at 1.53g/cc (Ref 57)

Specific Heat: $0.0523 + 6.62 \times 10^{-4}T$ cal/g/°C over the temp range of 200–403°K (Ref 54)

Coefficient of Thermal Expansion 0.32×10^{-3} /deg (Ref 36)

Longitudinal Sound Velocities and Hugoniot

Data: U = shock vel; u = particle vel; c_g = longitudinal sound vel

ρ (g/cc)	c_D (km/sec)	U (km/sec)	Valid U range (km/sec)
1.30	1.1	2.16 + 1.43u	2.58 – 4.16 (Ref 40)
1.40	1.13	1.61 + 1.97u	2.20 – 4.07 (Ref 40)
1.50	1.36	2.17 + 1.62u	2.63 – 4.17 (Ref 40)
1.60	1.66	2.36 + 1.53u	2.86 – 4.25 (Ref 40)
1.70	2.04	2.48 + 1.42u	3.08 – 4.17 (Ref 40)
0.82	–	0.37 + 1.9u	– (Ref 44)
0.86	0.35	0.35 + 1.75u	– (Ref 43)
1.73	2.17	2.17 + 1.91u	– (Ref 43)
1.68	2.27	–	– (Ref 57)

Grüneisen Constant: 1.65 at high pressures (Ref 43)

III. Preparation, Chemical Properties and Toxicity

The two commercial methods of preparing Tetryl via nitration of dimethylaniline, or production of dinitromethylaniline and its subsequent nitration, were described under "Nitration" in Vol 8, N71-L to N72-L. Because the first of these reactions involves the oxidation of a methyl group it is highly exothermic and great care must be exercised to control the reaction temp. The second process proceeds with less gas evolution than the first and is less likely to be violent. In the lab, high purity Tetryl can be obtained by nitrating dimethylaniline with nitric acid (not mixed acid) in the presence of inert solvents such as dichloromethane, chloroform or carbon tetrachloride (Ref 18)

A number of by-products are formed in the preparation of Tetryl (Ref 34). Commercial dimethylaniline contains some methylaniline, which is nitrated to 2,3,4,6-tetranitrophenylnitramine (also called m-nitroethyl) which in turn is readily hydrolyzed to the substance below:

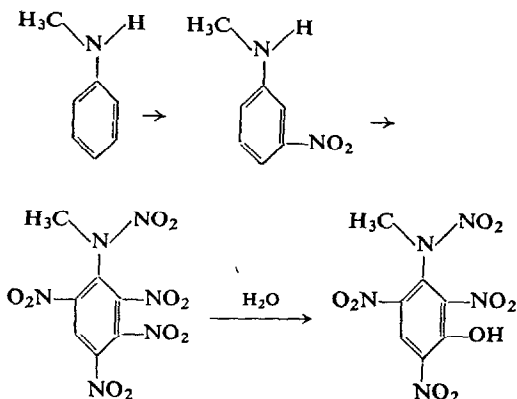

Other by-products are the following thermally labile benzidine derivatives:

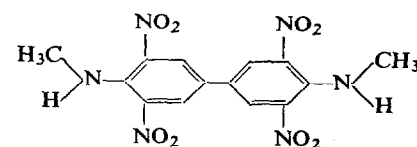
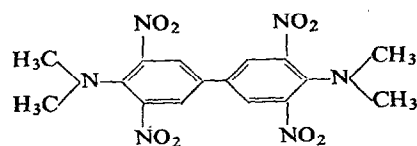

and:

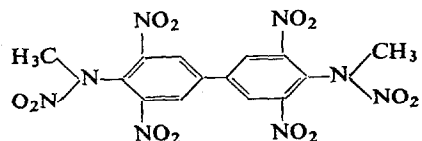

According to Urbański (Ref 34), Tetryl is highly resistant to attack by dilute mineral acids, but does react with concd acid or weakly basic solns. Trinitrophenyl methylamine,

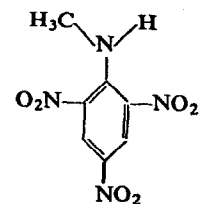

is formed when Tetryl reacts with concd sulfuric acid or with phenol. When Tetryl is boiled with a soln of Na carbonate (or dilute aq NaOH or KOH), the nitramino group is hydrolyzed as follows:

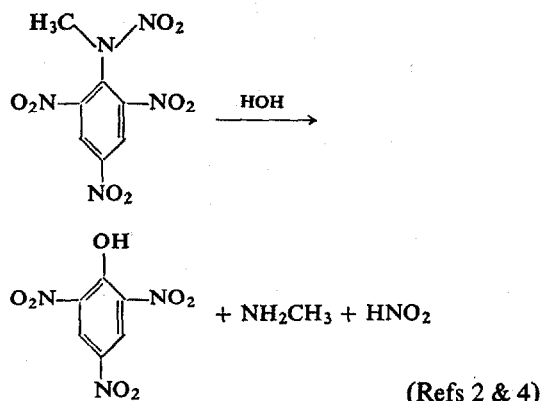

Tetryl reacts with aniline even at room temp to form 2,4,6-trinitrodiphenylamine and methyl-nitramine:

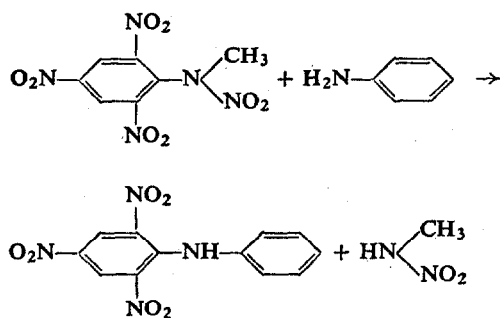

Prolonged heating of Tetryl at 120° yields Picric Acid (see Vol 8, P285-R to P295-L). Tetryl is reduced and hydrolyzed to 2,4,6-triaminophenol by the action of tin and hydrochloric acid (Ref 3)

Tetryl and TNT form an addition compd with a mole ratio of 1:2 (Ref 13). Another addition compd is a 1:1 mole ratio formed with naphthalene (Ref 7)

Tetryl may be destroyed by boiling it in a soln of Na carbonate

Tetryl forms ordinary eutectic mixts with 76.5% trinitro-m-xylene (mp 118.8°) and 29.5% trinitroanisole (mp 22.8°) (Ref 13)

A number of *homologs* and *analogs* of Tetryl are known. For example

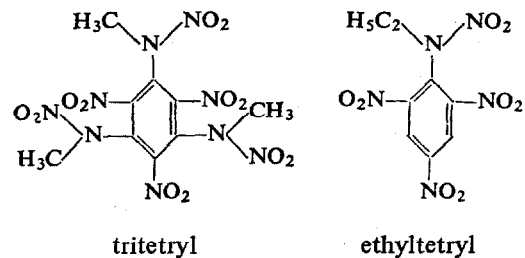
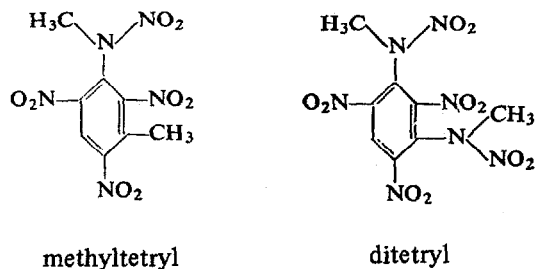

For a description of these and other compds see Ref 34, pp 62-70

Tetryl is fairly resistant to degradation by gamma-radiation. Exposure to a 10⁴ Curie Co⁶⁰ source (1.173 and 1.332Mev gamma rays), produced some erratic results, but on the whole the changes induced by this exposure were not great. According to Avrami et al (Ref 55), a sample exposed to 1.4 x 10⁷R passed the 120° vacuum stability test, but a sample exposed to 1.2 x 10⁸R could only pass the 100° test and failed in the 120° test. Weight loss increased dramatically when exposure levels were increased from 1.3 x 10⁸R to 10⁹R. Irradiated samples did not show much change over control samples in the DTA test until exposure levels reached 1.2 x 10⁸R, and even at 10⁹R changes were moderate

The expl behavior of Tetryl (impact, detonation vel, expl temp) was also only mildly affected by exposure to gamma radiation

According to a PicArns compilation of the compatibility of expls with plastics and adhesives (Ref 35), Tetryl shows negligible reaction with: Adhesive EC 1099, Dapon resin, Delrin, Epoxy 907 adhesive, Galvanoplast, conductive paint, Glastimat No 1, Lexan, Loctite 404, Molylube No 18, Permacel PN 112 tape, Polyesters, polysulfide rubber sealant, polyurethane EP 626/628, RTV 102 and 732 vulcanizing rubbers, Silastic RTV 731 or 732 (uncured), Silicone No SE 1201 and No Q 95-011, urea-formaldehyde. In the compilation by Dobratz (Ref 57), Tetryl is listed as being compatible with the following adhesives: Adiprene L-100, L-167 and LD-213, and Eastman 910

Tetryl does not react (is compatible) with Al, Sn, Cu, Ni, Pb, Cu-plated steel, bronze and stainless steel. There is a slight reaction with Zn, Fe, tin-plated steel, parkerized steel and brass. Tetryl reacts readily with steel (Ref 14). According to the compilation in Vol 8, M64

(Table 1), Tetryl corrodes steel heavily and iron slightly. There is very slight corrosion with Zn and Zn-plated steel. There is slight reaction and corrosion with Monel metal and no corrosion with Ti, Ag, Al, Cd, Cu, Ni, Pb and stainless steel

According to Sax (Ref 36a), Tetryl is a moderate acute local and acute systemic irritant (for both ingestion and inhalation) as well as a moderate chronic local and chronic systemic irritant. Troup (Ref 10) claims that breathing its dust induces symptoms of poisoning and concn of $1.5\text{mg}/\text{m}^3$ of Tetryl dust in the air is reported noxious, but a lower concn may be toxic. Tetryl has a particularly strong effect on skin, producing symptoms of an allergic character; the skin turns yellow and dermatitis develops. Consequently, workers employed in production, especially those engaged in handling Tetryl, should use protective clothing. Parts of the body exposed to Tetryl dust should be protected by a layer of cream containing 10% of Na perborate, and daily baths are essential. Presence of Tetryl dust in the air often causes irritation of the upper respiratory tract. Tetryl poisoning is also accompanied by general symptoms such as lack of appetite, insomnia, giddiness, etc. The symptoms usually occur 2–3 weeks after beginning work with Tetryl. In many cases (60–68%) some adaptation occurs and the effects of the poisoning appear less pronounced

In a Tetryl plant in the US, during WWII, out of 1258 workers engaged in handling Tetryl, 944 fell ill, while in another, 404 out of 800–900 were affected (Ref 8)

IV. Analytical and Mil Specs

A qual test for Tetryl dissolved in ethanol is the formation of a red color on addition of am-

monium hydroxide. This test is sensitive to about 0.01mg of Tetryl (Ref 47). The IR spectrum of Tetryl, according to Ref 47 is:

Quan detn of nitramine N can be obtained by the gas evolution method using ceric ammonium nitrate solns (Ref 47). Nitramine and nitro N can be detd by the chromous chloride method

A highly sensitive liq chromatographic method is described by Stanford (Ref 67). With UV detection, sensitivity may be as great as 50–250ppb of Tetryl in w in the presence of TNT and RDX. The mobile phase is a 50% methanol soln in w

An even more sensitive method for detg down to 20ppt of Tetryl in seawater is described by Hoffsommer et al (Ref 48). The seawater is extracted with benz, which is then evapd to a small vol and injected into a gas chromatograph. The traces are compared with traces of standard Tetryl solns. The method is also applicable to TNT and RDX

Tetryl can be sepd from its degradation products by high pressure liq chromatography using a mixt of cyclohexane-chloroform-tetrahydrofuran. Picramide and Picric Acid are the main decompn products of Tetryl heated at 80°C (Ref 63)

Yasuda (Ref 42a) used thin layer chromatography to obtain qual and quan analyses of Tetryl impurities and decompn products

US Mil Spec: Mil-T-339C (1973) supersedes *Mil-T-0339B* (1971):

Color: light yellow

Moisture: 0.1% max

MP: 129.5° max and 128.8°C min

Insoluble: 0.1% max in benzene

Acidity: 0.02% max as sulfuric acid

Granulation: thru No 12 Std US Screen,

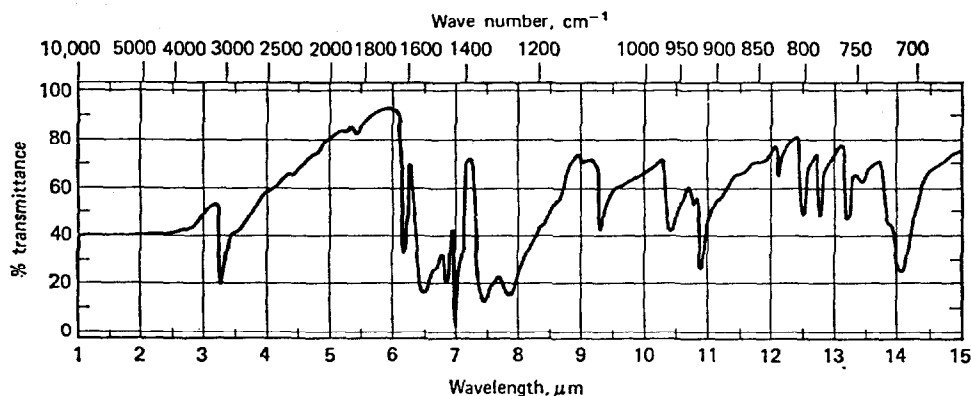

100% min

thru No 16 Std US Screen, 95% min
thru No 60 Std US Screen, 30% max
thru No 100 Std US Screen, 5% max

V. Thermal Decomposition

Like most other expls, Tetryl decomps in a very complex fashion. The condensed phase decompn is autocatalytic but initial rates appear to be first order. The best existing studies of the thermal decompn of Tetryl appear to be those of Dubovitskii and coworkers (Refs 22 & 23). They followed the decompn by gas evolution and product analysis, as well as by heat evolution (measured by a differential calorimeter method) and wt loss. Although both studies clearly showed the autocatalytic nature of the reaction, the kinetic constants obtained from gas evolution do not agree with those obtained from heat evolution or wt loss measurements. For example, k_1 , the first order initial rate constant is $10^{13.9} \exp(-36000/RT)$, sec^{-1} by heat evolution or wt loss over 130–55°, whereas $k'_1 = 10^{16} \exp(-40000/RT)$ by gas evolution over 140–65°. Similarly, the "effective" autocatalysis constants are $10^{15.6} \exp(-38500/RT)$ for the former and $10^{14.5} \exp(-35500/RT)$ for the latter. Note that k_1 obtained by Cook & Abegg (Ref 16), $10^{12.9} \exp(-34900/RT)$, agrees fairly well with Dubovitskii's k_1 , whereas the Rideal & Robertgson k'_1 (Refs 12 & 12a) of $10^{15.4} \exp(-38400/RT)$, and confirmed by Rogers & Smith (Ref 34b), agrees quite well with k'_1 . Harris used a DTA method to get an activation energy of 34000cal/mole, in rough agreement with the heat evolution or wt loss data

According to Dubovitskii et al (Ref 22), the heat of reaction of a slow decompn of Tetryl is

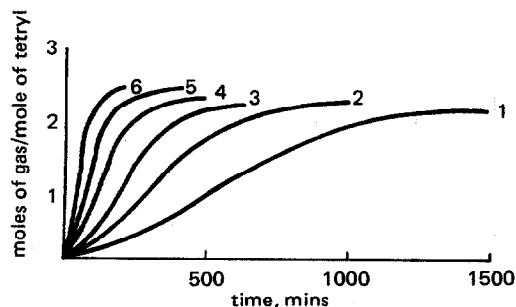

Fig 1 Kinetic gas-evolution curves in the decomposition of tetryl; 1) 140.3°; 2) 145.3°; 3) 150°; 4) 154.8°; 5) 160°; 6) 164.9°

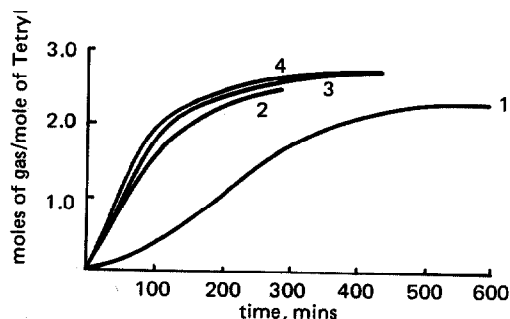

Fig 2 Kinetic gas-evolution curves in the decomposition of Tetryl with the addition of Picric Acid at 150°: 1) Tetryl alone; 2) 0.62 mole of Picric Acid per mole of Tetryl; 3) 1.26 moles of Picric Acid per mole of Tetryl; 4) 2.57 moles of Picric Acid per mole of Tetryl

341cal/g. This value is in excellent agreement with the 328cal/g reported by Hall (Ref 46)

The rate of gas evolution of Tetryl exhibits the characteristic autocatalytic shape as shown in Fig 1 (Ref 23)

Table 1 (also from Ref 23) shows the compn of gas products. Note the predominance of N_2 in the products

Table 2 (Ref 23) gives the condensed phase products of the thermal decompn of Tetryl at 160°. Aside from undecompd Tetryl, Trinitroanisole is the major product, although it tends to disappear on prolonged heating apparently forming Picric Acid, whose concn rises sharply at long decompn times. Note that the amount of condensed phase decreases on long heating. Consequently long heating favors production of gaseous decompn products

Addition of the Trinitroanisole or Trinitroaniline to Tetryl produces a slight retarding effect on the gas evolution. This contrasts sharply with the effect of adding Picric Acid. As shown in Fig 2, Picric Acid greatly enhances the decompn rate

Indeed, addition of Picric Acid wipes out the autocatalytic shape of the gas evolution curves of pure Tetryl. It is not clear whether this effect is due to reactions with Picric Acid or specifically to proton transfer from the Picric Acid. Unfortunately, addition of other proton donors (eg, mineral acids) was not tried

Presumably the $\text{N}-\text{NO}_2$ bond at around

Table 1
Composition of Gaseous Products of Tetryl Decomposition

Expt. No.	Time mins	Moles of gas per mole of Tetryl	Composition of dry gas, vol %				Composition of gas, moles per mole of Tetryl				
			CO ₂	CO	NO	N ₂	CO ₂	CO	NO ₂	NO	N ₂
1	221	0.650	23.6	10.6	4.3	61.5	0.134	0.060	0.016	0.024	0.348
2	1530	2.208	25.9	12.0	5.3	56.8	0.493	0.229	0.000	0.101	1.080
3	40	0.450	25.1	10.9	5.0	59.0	0.087	0.035	0.021	0.017	0.204
4	50	0.667	24.5	11.3	6.3	57.9	0.124	0.057	0.018	0.032	0.282
5	80	1.338	23.9	11.1	8.2	56.8	0.243	0.113	0.031	0.084	0.578
6	110	1.808	24.3	10.8	8.1	56.8	0.358	0.158	—	0.118	0.838
7	140	2.010	25.2	11.5	8.5	54.8	0.420	0.193	0.016	0.143	0.925
8	200	2.149	25.1	11.8	8.6	54.5	0.448	0.210	0.004	0.153	0.972
9	422	2.304	25.7	12.1	8.2	54.0	0.491	0.231	0.001	0.156	1.030
10	1440	2.674	27.8	13.4	8.4	50.4	0.624	0.302	0	0.190	0.130
11	40	1.950	24.5	11.6	8.8	55.1	0.397	0.188	0.023	0.142	0.892
12	382	2.572	27.7	12.7	9.6	50.0	0.584	0.268	0.003	0.202	1.060

Table 2
Composition of Condensed Phase (160°)

Expt. No.	Time mins	Wt of residue as % of m ₀ *	Moles per mole of Tetryl			
			Tetryl	2,4,6-trinitro-anisole	Picric Acid	N-methyl-2,4,6-trinitroaniline
1	25	95.6	0.832	0.073	0.037	0.030
2	45	90.0		0.195		0.034
3	55	86.9	0.494	0.265	0.094	0.045
4	70	83.8		0.295	0.113	
5	90	80.5	0.227	0.412	0.131	0.072
6	111	78.2		0.503		
7	145	75.9	0.029	0.525	0.160	0.065
8	300	74.2	0.019	0.478	0.204	0.047
9	400	73.2		0.463		
10	1440	69.0	0	0.110	0.524	0.031

* Initial quantity of Tetryl

40Kcal/mole (Ref 70) is the weakest bond in the Tetryl molecule. Thus the reaction

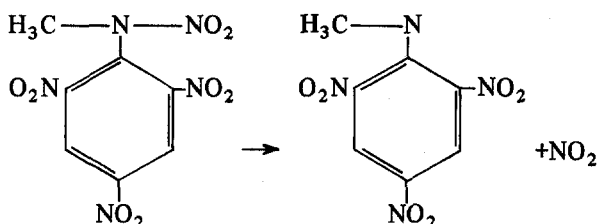

is expected to be the primary step in the decomn. The subsequent reactions have not been determined

Dubovitskii (Ref 23) presents some highly speculative subsequent steps to account for the observed products. However, these steps are neither plausible

nor do they constitute a complete decomn mechanism. Clearly much additional work is needed before the decomn mechanism of Tetryl is established

Thermal decomn of Tetryl was examined by Rogers (quoted in Ref 56) via DTA (differential thermal analysis) and thermal conductivity measurements. His results are shown in Fig 3. In the particular sample examined, melting started at 128° and rapid decomn at about 198°

VI. Detonation Characteristics

Included in this section are the steady state detonation properties of Tetryl. Initiation behavior will be treated in Section VII

Detonation Velocity and LVD

According to Cook (Ref 17) the ideal detonation velocity of Tetryl is given by:

$$D = 5600 + 3225 (\rho_0 - 1.00) \text{ m/sec}$$

where D = deton vel and ρ_0 = packing density. D calculated by this eqn for $\rho_0 = 1.71\text{g/cc}$ agrees very well with $D = 7850\text{m/sec}$ for that d given in Ref 46a. Even better agreement is obtained with Coleburn's measurement of 7581m/sec at 1.61 g/cc (Ref 26). Measurements by Warren (Ref 56) of $D \simeq 7300\text{m/sec}$ at 1.60g/cc and a charge diam of 1/2 inch are about 200m/sec lower than those computed by Cook's eqn

Cook also showed that ideal detonation velocity in coarse Tetryl at 1.05g/cc is achieved at charge diameters above 3cm (Ref 17, p 53), provided adequate initiation is used

These D vs diameter, d , curves are shown by the solid line in Fig 4. With weak initiation, transient but reproducible effects are observed, as indicated by the broken lines in Fig 4

Low velocity detonation, *LVD*, in Tetryl has been observed by several investigators (Refs 29, 38 & 45). The curves of Fig 5 (from Ref 29) are similar to those of Cook (Fig 4). Stable *LVD* is claimed when coarse Tetryl is initiated weakly. Above a certain diameter (which varies with particle size), *LVD* is stable only over short distances of the order of 2-4 charge diameters, and then abruptly transits into normal detonation. Below this diameter *LVD* can be stable for lengths of up to 25 charge diameters. *LVD* is not affected by the initiating power of the detonator, provided the detonators are weak enough not to initiate normal detonation

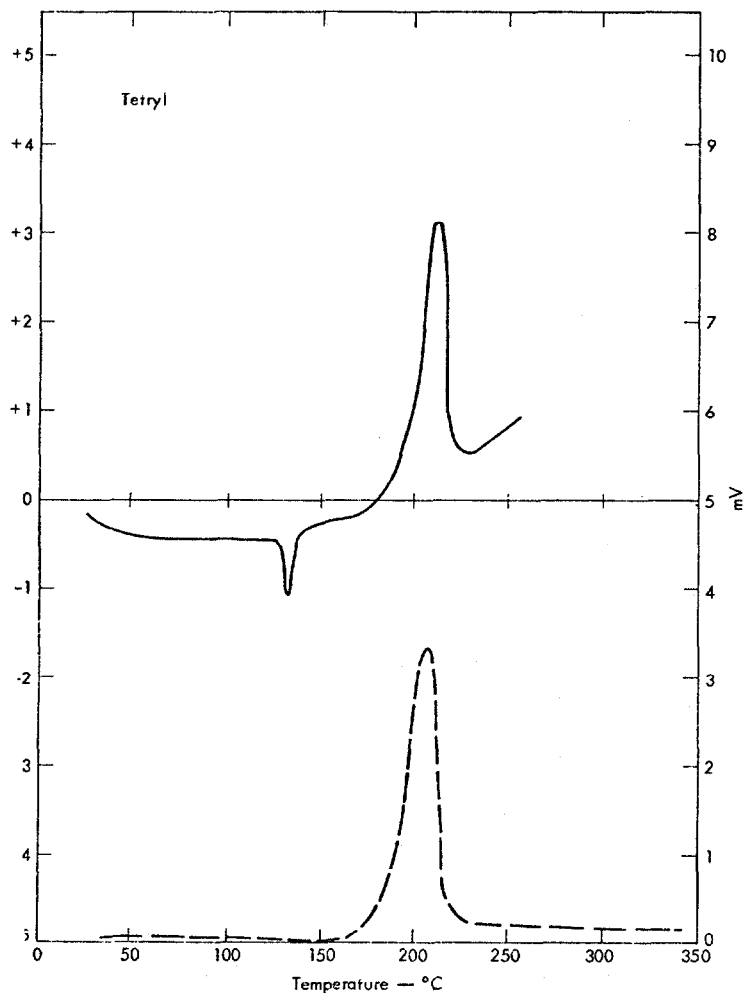

Fig 3 DTA curve (solid line) and pyrolysis (thermal conductivity) curve (dashed line) for Tetryl

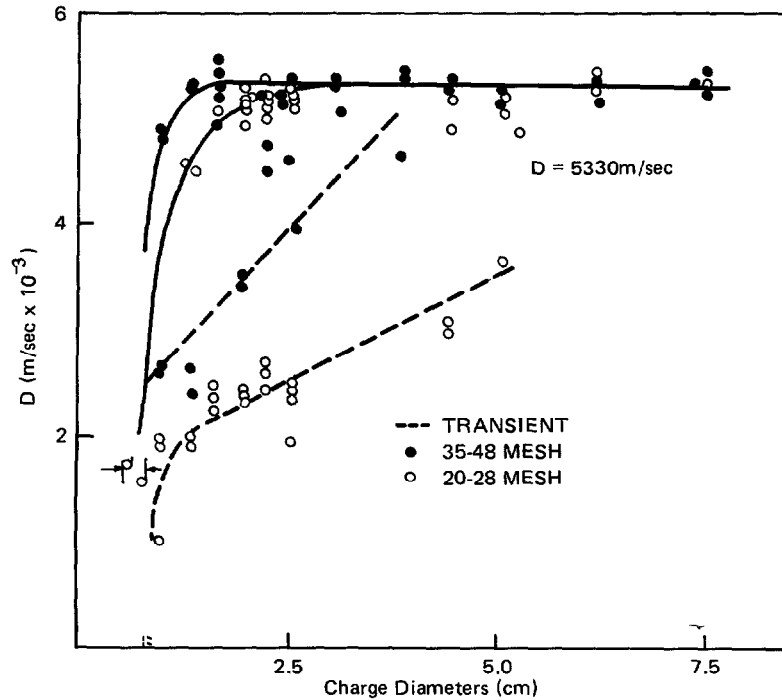

Fig 4 Detonation vs Charge Diameter Curves for Coarse Tetryl

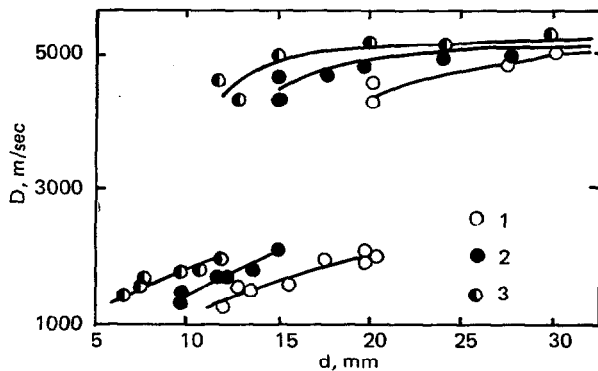

Fig 5 Steady-state detonation velocity of Tetryl ($\rho_0 = 0.9\text{g/cm}^3$) as a function of charge diameter. Particle size, in mm: 1) 1.0-1.6; 2) 0.63-1.0; 3) 0.4-0.63

In a more recent study, Parfenov & Voskoboynikov (Ref 38) obtained the following data for 0.9g/cc Tetryl (D denotes normal detonation):

Particle size (mm)	Min diam for LVD (mm)	Min diam* for D (mm)	Transi-tion diam (mm)	Min LVD (km/sec)	Max LVD (km/sec)
0.5	7	13	13	1.4	2.1
0.8	9	15	16	1.3	2.3
1.3	12	20	21	1.3	2.2

*with strong initiation

It is noteworthy that max LVD (ie, LVD at transition diam) is independent of particle size, and indeed of the type of expl (it is essentially the same for TNT, PETN, RDX and Tetryl). For charge diameters between min diam for LVD and min diam for normal detonation, even powerful initiators will produce only "steady" LVD provided the charge is of sufficient length. For 1.3mm Tetryl particles at 0.91g/cc and charge diam $d = 20\text{mm}$, it was found that LVD = 2.14km/sec and LVD pressure is about 14.5kb. Expts with oil-coated or crushed particles suggest that the main reaction in LVD is a surface combustion

Vashchenko et al (Ref 45) obtained the following results with 1–1.6mm Tetryl particles at 0.95g/cc, $d = 20\text{mm}$ and $\ell = 100\text{mm}$: $LVD = 2.1\text{km/sec}$; $D = 4.5\text{km/sec}$; $Q_{LVD} = 680\text{cal/g}$; $Q_D = 1030\text{cal/g}$ (Q is the heat of detonation). They claim that in LVD about 20% of Tetryl does not react. Differences in observed product compn for LVD and D will be described later

Closely related to the precise measurement of detonation velocity is the subject of detonation front curvature. Front curvature of Tetryl was examined at the Naval Ordnance Laboratory (NOL) (Refs 31 & 39). For point-initiated charges of 1.51g/cc, it was found that the radius of curvature of the detonation front increases with charge length in the manner expected for spherical expansion of the front. The radius of curvature is also a function of the chemical nature of the expl, its particle size and its packing density

Detonation Pressure

Coleburn used the "aquarium" method to measure the detonation pressure, P_j , of a series of expls (Ref 26). For Tetryl pellets of 5.1cm diam and 1.614g/cc, he gives $P_j = 226\text{kb}$. Warren, who also used the aquarium method, gives $P_j \approx 207\text{kb}$ for 1.60g/cc Tetryl charges of 1/2 inch diam (Ref 56). When one considers that Warren's $D = 7.26\text{km/sec}$ (non-ideal deton because of small diam), agreement with Coleburn is very good

Edwards et al measured the particle velocity, u , of pressed Tetryl pellets of 5.08cm diam at 1.51g/cc as a function of time using an electromagnetic velocity gage (Ref 51). Under these conditions $u = 1.75\text{km/sec}$ with an apparent reaction time of about 0.1 microsec. Coupling this u with $D = 7.17\text{km/sec}$ and $\rho_0 = 1.51\text{g/cc}$, yields $P_j = 189\text{kb}$. The adiabatic coefficient, Γ , for all 3 measurements (Ref 26, 51 & 56) lies between 3.0 and 3.1 where $\Gamma + 1 = \rho_0 D^2 / P_j$

Heat of Detonation, Q

The most recent measurements appear to be those of Pepekin et al (Ref 68). Their samples were confined in brass and the results are reported with w (a major deton product) considered to be gaseous. At $\rho_0 = 1.69\text{g/cc}$, $Q = 1160\text{cal/g}$ and at $\rho_0 = 0.98\text{g/cc}$, $Q = 960\text{cal/g}$. They provide an eqn for computing Q at intermediate densities, namely $Q = 680 + 282\rho_0$. Ornellas (quoted in Ref 57) gives 1090cal/g at 1.51g/cc, in reasonable agreement with the above eqn. It should be noted that these measured values are considerable lower than those computed for the ideal deton state, Q_j . Pepekin gives $Q_j = 1443\text{cal/g}$ for Tetryl, in good agreement with 1416cal/g calcd by the writer from computed deton products given by Mader (Ref 24a)

Detonation Products

There are no measurements of detonation products in the detonation state. Whatever pro-

Table 3
Observed and Computed Detonation Product Compositions
(moles product/kg Tetryl)

	Observed $\rho_0 = 1.56$	Computed $\rho_0 = 1.60$	Observed $\rho_0 = 0.9$	Computed $\rho_0 = 1.00$	Observed LVD $\rho_0 = 0.95$
CO ₂	5.59	9.00	3.02	4.75	0.21
CO	10.85	1.16	18.83	10.17	12.54
C _(s)	5.80	14.22	0.30	9.43	11.64
H ₂ O _(g)	5.91	8.70	3.03	8.20	(a)
H ₂	1.84	—	3.64	0.33	1.74
NO	—	—	—	—	7.94
N ₂	7.82	8.70	7.73	8.68	4.74
NH ₃	—	—	0.30	0.05	(a)
HCN	0.60	—	1.20	—	(a)
C ₂ N ₂	0.58	—	0.20	0.04	(a)
CH ₄	0.27	0.0003	0.48	—	(a)
Q(cal/g)*	1122	1405	941	1215	680

*Computed by the writer from the product compn shown

(a) not given

duct measurements exist are for much milder conditions of pressure and temp than those of the detonation state. In Table 3 we compare measured product compns reported by Baum et al (quoted in Ref 19a – source of original data not given) with the computed compns of Mader (Ref 24a)

Obviously there is a great difference between observed and computed product compns. As suggested above, this is due to different product equilibria controlling product compns in the detonation state, and at some “frozen” equilibrium in the expanded products in a bomb-technique measurement. There is also an appreciable difference between observed products in a normal detonation and products of LVD

Critical Diameter, d_c

According to Parfenov & Voskoboinikov (Ref 38) the critical diameters for 0.9g/cc Tetryl are 13, 15 and 20mm for particle sizes of 0.5, 0.8 and 1.6mm, respectively. Baum et al (Ref 19b) gives $d_c = 5.7$ mm for cast Tetryl at 1.6g/cc. Cook's value for d_c of 20–28 mesh or 35–48 mesh Tetryl at 1.05g/cc is about 7 to 8mm (Ref 17, p 53)

Performance

In the *Ballistic Mortar* and *Trauzl Block* tests, Tetryl is 130% and 125% of TNT, respectively (Ref 46a). In air shock overpressure, in the 3–20psi range, the *TNT equivalent weight* of Tetryl is 1.07 (Ref 62). In underwater performance, the *Pentolite equivalent weight* of Tetryl is 1.00 for shock energy and 0.98 for bubble energy (Ref 20). The *Gurney Constant* for 1.62g/cc Tetryl (quoted in Ref 71) is 2.5km/sec. This value seems low

Jaffe & Clairmont (Ref 31) studied the effects of configuration and confinement on the performance of Tetryl boosters. They found that: 1) there is no significant difference in the performance of cylindrical boosters or truncated cone boosters; 2) booster length, not booster geometry, controls shock attenuation in Plexiglass in contact with the booster; and 3) booster effectiveness increases with its length even at length-to-diameter ratios of 4

Detonation Light

Tetryl was one of three expls used in Blackburn & Seely's study (Ref 28) of the origin and nature of detonation light. They obtained some fine photographs with coarse Tetryl that show

light flashes of about the same size as the interstices between Tetryl grains. In fine particle, high d, pressings of Tetryl detonation light is much fainter than in coarse, lower d pressings. These observations, together with observation of the effects of interstitial gas, led these authors to postulate a stagnation of particle flow against neighboring still unreacted grains as the source of detonation light

Electrical Conductivity

No increase in electrical conductivity was observed upon detonation of Tetryl (Ref 52). This differs from TNT for which conductivity increased markedly. The difference is ascribed to the presence of large amts of free carbon in the products of TNT detonations

VII. Initiation Behavior

Because Tetryl was widely used as a booster charge, its initiation behavior has been studied extensively. In particular, the reaction of Tetryl to shock has been the subject of many investigations. We shall now summarize the initiation characteristics of Tetryl with emphasis on its shock initiation behavior. The transition from burning to detonation will be described in the next section

Shock Initiation

The most detailed studies of the shock initiation of Tetryl are those of Lindstrom (Ref 40) and those made at NOL (Refs 30, 32, 41 & 42). Lindstrom used large diameter, unconfined charges and plane-wave shocks. Threshold pressures and particle velocities to just initiate detonation (computed by the writer from Lindstrom's data in Ref 42a) are shown in Table 4

Note that threshold pressures decrease rapidly as packing d decreases, but *particle velocities stay essentially constant* (with the possible exception of Tetryl at 1.7g/cc, which is 98% crystal d)

Table 4
Plane-Wave Shock Initiation Threshold for Tetryl

ρ_0 (g/cc)	Pressure (kb)	Particle Velocity (km/sec)
1.70	~21	~0.40
1.60	9.5	0.29
1.50	5.5	0.26
1.40	4.5	0.28
1.30	3.0	0.27

NOL data from Ref 32 (recomputed in Ref 42a) are summarized in Table 5. The terms SSGT and LSGT are NOL descriptions for their usual gap tests (see under "Shock Sensitivity of Explosives" in this Vol)

Table 5
Gap-Test Initiation Thresholds for Tetryl

Test	ρ_0 (g/cc)	Pressure (kb)	Particle Velocity (km/sec)
SSGT	1.43	7.9	0.30
	1.54	8.5	0.32
	1.62	12	0.36
	1.69	~20	~0.39
	1.42 (a)	7.8	0.31
	1.50 (a)	8.0	0.33
	1.66 (a)	18.5	0.40
LSGT	1.43	5.6	0.29
	1.49	6.6	0.30
	1.64	12.5	0.33
Unconfined (Ref 30)	1.65	18	~0.4

(a) Different Tetryl sample from the one above

Obviously the variation of threshold pressure or particle velocity in gap tests is analogous to that observed with plane-wave shocks

The data in Refs 32 & 41 lead to the following tabulation of the effect of diameter of confined 1.47g/cc Tetryl charges on threshold pressure (in the expl at its interface with the barrier):

Diameter (inches)	Threshold Pressure (kb)
0.054	14.5
0.100	11.7
0.200	7.5
2.000	6.3
0.100 (a)	14.4

(a) light confinement

Scott (Ref 41) also investigated the effect of cooling Tetryl on its shock initiation behavior. Confined and lightly confined charges at 1.47 g/cc and 0.100 inch diam were found to have the following pressure thresholds:

	Room Temp	~ -65°C
Confined	14.7kb	14.5kb
Lightly confined	14.4kb	17.6kb

A further study by Scott (Ref 42) was concerned with effect of expl particle size on pressure thresholds. At about 1.5g/cc, approx pressure thresholds are 10.5kb and 7.5kb for thru 325 mesh Tetryl, and thru 40 on 60 mesh or thru 10 on 20 mesh, respectively. At about 1.6g/cc, the 10 on 20 mesh Tetryl threshold was about 14kb, and slightly less for the 40 on 60 mesh Tetryl. However, the coarse Tetryl showed some reaction at lower input pressures than the 40 on 60 material. These partial reactions with coarse Tetryl, but not thru the 325 material, were also observed at 1.58g/cc

Liddiard & Jacobs (Ref 30) also observed deflagration type reactions with 1.65g/cc Tetryl. They found a deflagration threshold pressure of 14kb as compared to 18kb for the detonation threshold. Bartels (Ref 50) investigated the shock behavior of coarse Tetryl at 1.65g/cc in a Plexiglass tube of 21mm ID. He claims that no reaction occurs below 7.2kb and reaction is observed regularly above 12.1kb. With recrystd Tetryl of a finer particle size, the no-reaction level shifts to 9.1kb, while the reaction level is still 12.1kb

Some of the complex phenomena occurring in a gap-test with a Tetryl donor charge were investigated in Ref 27. A result of some importance to our subsequent discussion is that the pressure of the NOL LSGT drops to about 1 kb in about 2 microsecs

Dremin et al (Ref 44), Koldunov et al (Ref 53), and Dremin & Shvedov (Ref 65a) observed the barrier interface velocity of several granular expls (including Tetryl) as a function of rectangular shock inputs. Their conclusions are summarized in this Vol under "Shock Sensitivity of Explosives". It will suffice to state here that neither inert liq nor gaseous fillers affected the results. Furthermore, grain shattering by low amplitude shocks may contribute to the shock-sensitivity of porous charges. Although such charges are "sensitive", transition to detonation is "slow"

The above-mentioned article in this Vol also describes the so-called *critical energy* concept of shock initiation. Walker et al (Ref 58) give a "critical energy" value of 11cal/cm² for Tetryl. Howe (Ref 49) presents a not very convincing "simplistic" model of shock initiation in granular expls. Based on some fairly drastic assumptions he computes a "reduced energy density" for the Tetryl data of Lindstrom (Ref 40) and then

shows that a plot of this vs "reduced time to detonation" is a single curve for $\rho_0 = 1.3, 1.4, 1.5$ & 1.6g/cc

An expldng bridge wire, EBW, is an alternate method of shock-initiating an expl. Leopold (Ref 37) studied the initiation of Tetryl by the EBW method. He examined the effects of particle size and packing d. Indications are that there is an optimum particle size for maximum EBW sensitivity. However, changes in crystal habit can produce large variations in EBW sensitivity. As expected, EBW sensitivity decreases as packing d is increased

Yet another form of shock initiation is provided by exposing expls to laser beams. Yang and Manichelli studied the action of Q-switched ruby or neodymium-glass laser pulses (Ref 65) on Tetryl and other expls. With the laser energy deposited in a thin metal film, and the shock generated therein transmitted to the test expl, detonation was not observed with high-d Tetryl at 4J max energy in a 1.43cm diam beam. At 1.08g/cc, however, Tetryl exhibited a very strange behavior in that a delayed detonation was observed which propagated a velocity 3 to 4 times higher than normal. Tetryl could not be initiated by direct exposure to the laser beam (no thin metal absorber)

Minimum Priming Charge

The smallest amt of primary expl required to reliably initiate detonation in a secondary expl is called the minimum priming charge. According to Martin (Ref 5) the minimum priming charges for Tetryl are:

Mercury fulminate	0.29g
Silver fulminate	0.02g
Lead azide	0.025g
Silver azide	0.02g

The min priming charges in Ref 46a are somewhat different, namely

Mercury fulminate	0.20g
Lead azide	0.10g

Incidentally, Tetryl containing 60% w cannot be detonated by a commercial detonator (Vol 8, M149-R)

Initiation by Heat

Henkin & McGill (Ref 15) give the following expl times for 25mg of Tetryl in copper shells of 0.635mm diam submerged into a hot Wood's metal bath:

Temp ($^{\circ}\text{C}$)	Expl Time (sec)
360	0.325
346	0.425
329	0.582
285	1.45
269	2.22
264	no expln

From these data, the 1 sec expln temp is 300° . Slightly different results are reported by Urbański (Ref 34, p 53) for Tetryl dropped onto a heated copper surface:

at 302°C ,	explodes in 0.4 sec
at 280°C ,	explodes in 1.1 secs
at 260°C ,	explodes in 2.0 secs
at 236°C ,	explodes in 6.2 secs

Andreev & Belyaev (Ref 21, p 476) report ignition in 5 secs at 257° , which is in rough agreement with Urbański. They also state that a 0.5g Tetryl sample, heated at the rate of $20^{\circ}/\text{min}$, ignites between $190-94^{\circ}$. Baum (Ref 19) states that Tetryl (wt or heating conditions not given) ignites in 40 secs at 180°

Rifle Bullet Sensitivity

Tetryl in capped cast iron pipes, 5cm diam & 5cm long, expls in 7 of 10 trials when shot thru with rifle bullets fired from a distance of 9m (Ref 21, p 473)

Initiation by Projectile Impact

When a projectile impacts on a bare expl charge, one normally observes either that the charge detonates or that it is scattered. The same is true for charges whose impacted face is confined, but are unconfined elsewhere. In this situation the projectile generates a strong shock in the expl, which causes reaction to take place, which then feeds energy into the shock and accelerates the shock towards detonation. This process is very rapid, and detonation generally occurs before the shock has propagated more than two or three projectile diams or, in most cases, in less than 10 microseconds. Confinement has little effect on the results

On the other hand, when a projectile impacts on a fully confined expl charge, a variety of results are possible. Sometimes explns occur which are quite violent, but they are not detonations. The time to expln in these situations can be hundreds of microseconds, and confinement can have a marked effect on the results

The projectile impact behavior of Tetryl (as

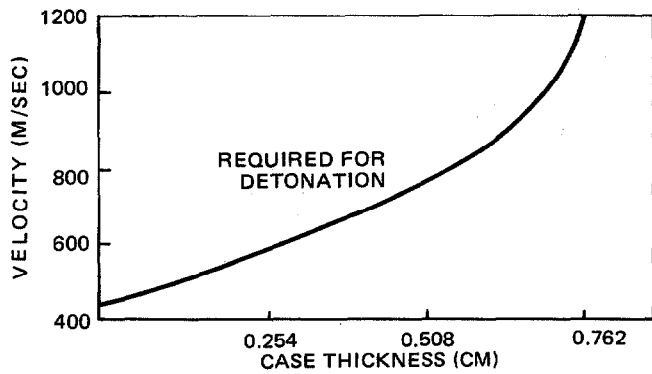

Fig 6 The impact velocity required for detonation. The projectile is 1.27cm long and 1.27cm in diam. The case and projectile are steel

well as other expls) was examined by Frey et al (Ref 64a). Fig 6 (adapted from Ref 64a) demonstrates the effect of front surface confinement on the projectile velocity required to detonate Tetryl

Frey et al also computed the "critical energy" for Tetryl in a somewhat roundabout way. Their results are shown in Table 6. Note that front surface confinement has relatively little effect, and projectile diam has virtually no effect on the computed critical energy. However, all the values in Table 6 are 2.5 to 3-fold greater than those reported by Walker et al (Ref 58)

Table 6
Critical Energies in Cal/cm² Calculated from
Projectile Impact Data on Tetryl

Projectile Diameter, cm	Cover Plate Thickness, cm				
	0	0.15	0.27	0.64	0.78
0.76	26.6	31.0	31.4	—	—
1.27	27.4	30.4	30.4	31.4	33.7
1.49	25.4	—	—	—	—
0.32 (brass)	25.4	—	—	—	—

Impact Sensitivity

This subject was covered in Vol 7, I35-R to I55-R, under "Impact, Initiation of Explosion By". Even qualitatively, there is disagreement about the impact sensitivity of Tetryl. Most laboratories rank it between HMX and Octol, but several claim it to be as sensitive as RDX. According to Russian investigators (Vol 7, I54), a quant impact sensitivity is given by \bar{P}_{cr} , a

critical stress. The value given for Tetryl is about $8.4 \times 10^{-3} \text{ kg/cm}^2$, with a critical thickness, h_{cr} , $\approx 0.012 \text{ mm}$. Their values rank Tetryl between RDX and Picric Acid

Kondrikov & Chubarev (Ref 61) examined the behavior of Tetryl impacted between two flat polished steel surfaces. The test samples were 10–15mm in diam (d) and 0.1–0.6mm thick (h). A rotating mirror camera was used to observe the events. The first event appears to be a slow deformation of the impacted sample accompanied by a rise in stress and d. The deformation velocity is of the order of several m/sec and the event lasts about 0.05 millisecc. The relative increase in sample diameter is about 4%. Both this increase and the duration, t_0 , appear to be independent of the impacting energy in the range of 2 to 4.5kgm. Above a critical stress, which varies with d/h, the sample ruptures and fragments escape from between the steel impacting surfaces. The escape velocity, u_1 , of these fragments is given by:

$$u_1 = 32(p_1 - 0.6) \text{ m/sec, when } p_1 \text{ is in kbars.}$$

Usually a second rupture occurs and sometimes even a third, and u_1 can attain quite high values of the order of several hundred m/sec. When u_1 is large enough, frictional heating can cause decompn and ignition of the fragments. The critical fragment velocity for Tetryl is about 300m/sec. Like u_1 and t_0 it is independent of impact energy

VIII. Deflagration to Detonation Transition (DDT) and Deflagration

Probably the most complete investigation of DDT of Tetryl is that of Bernecker et al (Ref 64) and Price & Bernecker (Ref 69). They studied DDT in "coarse" (470 micron) and "fine" (20 micron) Tetryl. The latter was prepd by w pptn of an acet soln of the coarse material. Their app is shown in Fig 7

An important parameter in the study of DDT is the length of the predetonation column, ℓ . Generally ℓ is detd from markings on the tube fragments; it is checked for consistency with the probe and gage records in the x-t plane. Unless otherwise indicated, ℓ values were measured to $\pm 3 \text{ mm}$

The effect of compaction on DDT was examined over the compaction range of 63–90% theoretical max d (TMD) for the coarse Tetryl,

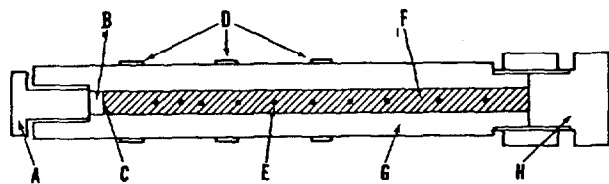

Fig 7 Cross Section of DDT Tube.
 (A—Igniter Bolt; B—Igniter; C—Igniter/
 Explosive Interface; D—Strain Gages;
 E—Ionization Probe Location; F—Explosive
 Charge; G—Tube; H—Bottom Closure.
 Inner Diameter=16.3mm, Outer Diameter=
 50.8mm. Distance From Igniter/Explosive
 Interface To Bottom Closure=295.4mm)

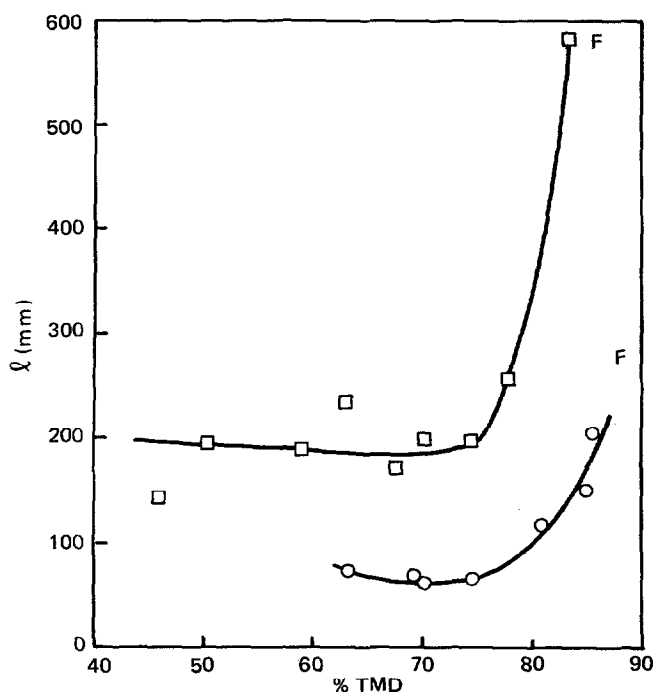

Fig 8 Effect of Compaction on Predetonation Column Length of Tetryl (□ 20 μ , ○ 470 μ)

and 46–85% TMD for the fine Tetryl. Although all Tetryl charges below 85% TMD exhibited a transition, their behavior differed from that found in earlier studies on RDX and RDX/wax (see “RDX” article in this Vol) in two ways: 1) the decompn products formed shortly after ignition had such a high electrical resistance that ionization probes frequently failed to respond to them, and 2) the onset of accelerated burning was

located nearer the onset of detonation than the ignition region. Both differences are attributed to the low temp decompn of Tetryl

As shown in Fig 8, coarse and fine Tetryl both showed the same qual effect of compaction on predetonation column length (l); a nearly constant l at high porosity with increasing values as the % TMD increases above 75%. At the same d values, the fine Tetryl had a greater l value than the coarse, as well as a longer relative time to detonation

Note that the curves have no well defined minimum as did those of 91/9 RDX/wax. In fact, l decreases with compaction to 75% TMD, and remains nearly constant as the porosity increases above 25%

Addition of 3% wax to 470 micron Tetryl at 66.5% TMD increased l from about 70mm (no wax) to about 240mm. This is a much greater increase than observed for waxed and unwaxed RDX. Furthermore, addition of wax apparently changes the initial low temp decompn behavior, observed in pure Tetryl, into behavior typical of other expls, in that accelerated burning in waxed Tetryl starts sooner (further away from the onset of detonation) than in pure Tetryl

Andreev & Chuiko (Ref 24) also examined the burning characteristics of Tetryl at high ambient pressures. For Tetryl particles of about 100 to 700 microns and packing d of up to 1.2g/cc, DDT was not observed in their app. Accelerated burning rates, however, were observed. Burning rates increased as gas permeability of samples increased. In agreement with the Bernecker et al studies, the accelerated regimes occurred sooner and at lower ambient pressures with coarse Tetryl than with fine Tetryl. Andreev & Chuiko invoke two possible schemes that may tend to “stabilize” burning in the accelerated regime and prevent DDT: 1) the high pressures that are obtained in accelerated regimes tend to eject unreacted material from the burning zone; and 2) at these high pressures the d of the air in the interstices is greatly increased and this densified air acts as a heat sink which cools the reaction zone

Andreev & Gorbunov (Ref 25) state that accelerating burning in Tetryl is not observed unless the ambient pressure exceeds 50 atm

Margolin & Chuiko (Ref 33) attempted to explain the occurrence of unstable, accelerating

burning of Tetryl (and other expls) in terms of gas dynamics. Although their explanations are not very convincing, they do stress the importance of porosity of the charge

According to Andreev et al (Ref 25a) the mass rate of burning, u_m , of Tetryl at ambient pressure, p , is given by:

$$u_m = 0.0630p^{0.695}$$

where u_m is in g/cm^2sec and p is in kg/cm^2 . This expression is valid for $10 \leq p \leq 250$ atm. The burning rate of Tetryl (as well as many other expls) is little affected by initial temp. For a temp increase of 100° the burning rate increases by a factor of less than two-fold. The apparent activation energy for this temp effect is about 7kcal/mole

Addition of small amounts of w reduces the burning rate of Tetryl packed to 1.21 to 1.35 g/cc. At 100 atm ambient pressure this effect is as follows:

Weight % of Water	u_m (g/cm^2sec)
0	1.55
2.4	1.32
2.7	1.35
4.4	1.20
6.0	1.12

A recent study by Glazkova (Ref 59) investigated the effect of additives on the burning rate of Tetryl. She gives a somewhat different dependence of u_m on p than that given in Ref 25a, namely:

$$u_m = 0.125p^{0.53} \text{ for } 10 \leq p \leq 100 \text{ atm}$$

$$\text{and } u_m = 0.026p^{0.873} \text{ for } 100 \leq p \leq 1000 \text{ atm}$$

The above relations are also claimed to hold for Tetryl with 5% of Cu oxalate. Other additives, in 5% amts, also had relatively little effect on the burning rate of Tetryl. This is shown as follows:

Additive	u_m	Pressure Range
5% Potassium Dichromate	$0.15p^{0.505}$	10-100
5% Potassium Dichromate	$0.018p^{0.96}$	100-1000
4% Potassium Dichromate + 1% carbon black	$0.073p^{0.133}$	30-100
4% Potassium Dichromate + 1% carbon black	$0.021p^{0.92}$	100-1000

The effects of heat loss on the stable combustion of Tetryl were examined theoretically by Knodrikov and Novozhilov (Ref 60). In particular they wanted to establish the effect of charge diam on the combustion characteristics of the charge. Expts were also made for comparison with theory. It was found that the combustion rate of Tetryl is practically independent of charge diam

Written by J. ROTH

Refs: 1) K.H. Mertens, Ber **10**, 995 (1877)
 2) P. vanRomburgh, Rec **2**, 31, 103, 304 (1883); **3**, 392 (1884); & **8**, 215 (1889) 3) P. vanRomburgh, Ibid **5**, 240 (1886); & **6**, 251 (1887)
 4) A.P.N. Franchimont & H.J. Backer, Rec **32**, 327 (1913) 5) F. Martin, "Uber Azide u. Fulminate (Habilitationsschrift)", Darmstadt (1913)
 6) W. Taylor & W.C. Cope, US BuMines Tech Paper 145 (1916); JSocChemInd (London) **35**, 1181 (1916) 7) N.N. Yefremov & A. Tikhomirova, AnnInstAnalPhysChim (USSR) **3**, 269 (1926); **4**, 92 (1928); A. Bogoyavlenskii & N.N. Yefremov, Ibid, **3**, 299 (1926) 8) L.J. Witkowski et al, J Amer Med Assoc **119**, 17 (1942)
 9) Davis (1943) 10) H.B. Troup, BritJIndMed **3**, 20 (1946) 11) A.F. Belyaev, ZhFizKh **22**, 91 (1948) 12) A.J.B. Robertson, Trans-FaradSoc **44**, 667 (1948) 12a) E.K. Rideal & A.J.B. Robertson, ProcRoySoc **A195**, 135 (1948) 13) N.N. Yefremov & O.K. Khaibashv, AnnInstAnalPhysChim (USSR) **17**, 130 (1949) 14) Anon, NOLR **1111**, Table 2-14 (1952) 15) H. Henkin & R. McGill, IndEngChem **44**, 1391 (1952) 16) M.A. Cook & M.T. Abegg, IndEngChem **48**, 1090 (1956)
 17) Cook (1958), 45 18) A. Semeńczuk & T. Urbański, BullAcadPolonSci, C1 III, **6**, 309 (1958) 19) F.A. Baum, K.P. Stanyukovich & B.I. Shekhter, "Fizika Vzryva" (Physics of an Explosion), FizMatGiz, Moscow (1959), 28 19a) Ibid, 159 19b) Ibid, 463 20) D. Price, ChemRev **59**, 801 (1959) 21) Andreev & Belyaev (1960), 356 22) F.I. Dubovitskii et al, ZhAkadNaukKhim **10**, 1763 (1960)
 23) Ibid, ZhFizKhim **35**, 255 (1961) 24) K.K. Andreev & S.V. Chuiko, Ibid **37** (6), 1304 (1963) & CA **59**, 6190 (1963) 24a) C.L. Mader, LA-2900, 114-23 (1963) 25) K.K. Andreev & V.V. Gorbunov, ZhVsesoyuzKhim-Obshch **8** (5), 592 (1963) 25a) Andreev et

- al, *Ibid*, 578 (1963) 26) N.L. Coleburn, **NOLTR 64-58** (1964) 27) I. Jaffee et al, **NOLTR 64-66** (1964) 28) J.H. Blackburn & L.B. Seely, *TransFaradSoc* **61** (3), 537 (1965) 29) A.K. Parfenov & A.Ya. Apin, *FizGorVzryva* **1** (1), 109 (1965) 30) T.P. Liddiard & S.J. Jacobs, **NOLTR 64-53** (1965) 31) I. Jaffee & A.R. Clairmont, **NOLTR 65-33** (1965) 32) D. Price & T.P. Liddiard, **NOLTR 66-87** (1966) 33) A.D. Margolin & S.V. Chuiko, *FizGorVzryva* **2** (3), 119 (1966) 34) Urbański **3** (1967), Chapt 3 34a) H.H. Cady, *ActaCryst* **23**, 601 (1967) 34b) R.N. Rogers & L.C. Smith, *AnalChem* **39**, 1024 (1967) 35) V.K. Canfield, *Addendum PATR 2595* (1968) 36) I.M. Voskobionikov et al, *FizGorVzryva* **4**, 45 (1968) & **CA 69**, 78872 (1968) 36a) Sax (1968), 1154-L 37) H.S. Leopold, **NOLTR 68-24** (1968) 38) A.K. Parfenov & I.M. Voskoboinov, *FizGorVzryva* **5** (3), 347 (1969) & **CA 73**, 5593 (1970) 39) J.O. Erkman & D. Price, **NOLTR 69-235** (1970) 40) I.E. Lindstrom, *JApplPhys* **41**, 337 (1970) 41) C.L. Scott, **NOLTR 70-36** (1970) 42) C.L. Scott, 5th DetSymp (1970), 259 42a) J. Roth, *Ibid*, 219 42b) S.K. Yasuda, *JChromatog* **50**, 453 (1970) & **CA 73**, 94387 (1970) 43) A.N. Dremin et al, *FizGorVzryva* **6**, 520 (1970) & **CA 75**, 89716 (1971) 44) A.N. Dremin et al, *Ibid* **7**, 103 (1971) & **CA 76**, 26892 (1972) 45) V.I. Vashchenko et al, *Ibid* **7**, 121 (1971) & **CA 76**, 26890 (1972) 46) P.G. Hall, *TransFaradSoc* **67**, 556 (1971) & **CA 74**, 103832 (1971) 46a) Anon, *Engrg-DesHndbk*, "Explosives Series, Properties of Explosives of Military Interest", **AMCP 706-177** (1971) 47) F. Pristera, *EncyclIndChem-Analysis* **12**, 405 (1971) 47a) M.A. Melnikov & N.P. Volkov, *IzvTomskPolytekhInst* **180**, 93 (1971) & **CA 76**, 88013 (1972) 48) J.C. Hofsommer et al, **NOLTR 72-215** (1972) & **CA 76**, 49532 (1972) 49) P.M. Howe, **BRL-MR 2151**(1972) 50) H. Bartels, *Explosivst* **20**, 143 (1972) & **CA 78**, 126457 (1973) 51) D.J. Edwards et al, **NOLTR 72-83** (1972) & **CA 78**, 13529 (1972) 52) A.N. Dremin et al, *FizGorVzryva* **8**, 150 (1972) & **CA 77**, 90771 (1972) 53) S.A. Koldunov et al, *Ibid* **9**, 295 (1973) & **CA 79**, 80989 (1973) 54) G. Krien et al, *ThermochemicaActa* **6** (5), 465 (1973) & **CA 79**, 119049 (1973) 55) L. Avrami et al, *PATR 4602* (1973) 56) T.W. Warren, **MHS MP 73-21** (1973) (NTIS 903000505) 57) B.M. Dobratz, "Properties of Chemical Explosives and Explosive Simulants", Lawrence Livermore Lab, Univ of California (1974) 58) F.E. Walker et al, *Proc8thSympExplPyrotech* (1974) & **CA 82**, 88201 (1975) 59) A.P. Glazkova, *FizGorVzryva* **10**, 323 (1974) & **CA 82**, 75127 (1975) 60) B.N. Kondrikov & B.V. Novozhilov, *Ibid* **10**, 661 (1974) & **CA 82**, 88202 (1975) 61) B.N. Kondrikov & V.D. Chubarev, *Combustn&Flame* **24** (2), 143 (1975) & **CA 83**, 82267 (1975) 62) M.M. Swisdak, **NSWC/WOLTR-75-116** (1975) 63) M.G. Farly & S.E. Wilson, *JChromatogr* **114**, 261 (1975) & **CA 84**, 124119 (1976) 64) R.R. Bernecker et al, 6thDetonSymp (1976), 426 64a) R. Frey et al, *Ibid*, 325 65) L.C. Yang & V.J. Menichelli, *Ibid*, 612 65a) A.N. Dremin & K.K. Shvedov, *Ibid*, 29 66) J. Harris, *Thermo-chimActa* **14**, 183 (1976) & **CA 84**, 107975 (1976) 67) T.B. Stanford, *FinalRept, Battelle Labs* (1977) (ADA 042598) 68) V.I. Pepekin et al, *DAN, KhimFiz* **232** (4), 852 (1977) & **CA 86**, 157803 (1977) 69) D. Price & R.R. Bernecker, **NSCW/WOLTR 77-96** (1977) & **CA 89**, 165659 (1978) 70) R. Shaw & F.E. Walker, *JPhysChem* **81**, 2527 (1977) 71) D.R. Hardesty & J.E. Kennedy, *Combustn&Flame* **28**, 45 (1977)

TETRYTOLS

Tetrytols are light yellow to buff colored mixts of *Tetryl* and *TNT*, usually in cast form. They have been used in boosters, burster charges, shaped charges, and demolition blocks. In much of their behavior, Tetrytols resemble Tetryl more closely than they resemble TNT. They are more "powerful" than TNT but not so "sensitive" as Tetryl. Furthermore, Tetrytol charges can be cast into munitons, which is an advantage over filling these munitions by pressing

Compn ranges and general characteristics of *Tetrytols* (from Ref 9) are shown in Table 1

Preparation: Tetrytol manufacture is similar to that of other "tol" mixts. TNT is heated and stirred in a melting kettle to about 100°C. Tetryl in the required amounts is then added to the molten TNT, and heating and stirring is continued. The temp is then gradually dropped. Filling of munitions is done at a temp where the Tetrytol mixt is still not too viscous for pouring (Ref 9)

Compatibility and Exudation

Compatibility with metals:

Dry: Copper, brass, aluminum, magnesium, stainless steel, mild steel, mild steel coated with acid proof black paint and mild steel plated with copper, cadmium, zinc or nickel are unaffected. Magnesium-aluminum alloy is slightly affected

Wet: Stainless steel and mild steel coated with acid-proof black are unaffected. Copper, brass, aluminum, magnesium, magnesium-aluminum alloy, mild steel and mild steel plated with

cadmium, copper, zinc or nickel are slightly affected (Ref 9)

70/30 Tetrytol is *incompatible* with 3M Adhesives EC 8708 and EC 1099. Tetrytol (compn unspecified) is compatible with neoprene (Ref 8)

All Tetrytols are subject to exudation above 65°C

Analytical and Solubility: TNT is extracted from Tetrytols with Tetryl-saturated carbon tetrachloride and the residue is Tetryl (Ref 1)

Tetrytols are soluble in the same solvents that dissolve TNT and Tetryl. Solubility levels depend on the proportion of each constituent in the Tetrytol

Explosive Characteristics

Detonation Velocity: For one-inch-diam unconfined charges the following deton velocities, *D*, were obtained (Ref 2):

75/25 Tetrytol (7 measurements), avg density = 1.57g/cc (range 1.55–1.60), avg *D*=7.35km/sec (range 7.29–7.41)

65/35 Tetrytol (5 measurements), avg density = 1.58g/cc (range 1.56–1.61), avg *D*=7.34km/sec (range 7.31–7.37)

These measurements agree with the ones quoted in Ref 3 (charge diam and confinement not specified), namely:

	d	D
75/25 Tetrytol	1.59g/cc	7.38km/sec
70/30 Tetrytol	1.61g/cc	7.34km/sec
65/35 Tetrytol	1.58g/cc	7.43km/sec

They are also in reasonable accord with a value of 7.31km/sec for 1-5/8" diam x 4" long Tetrytol at d=1.64g/cc, confinement not specified (Ref 7)

Table 1
General Characteristics of Tetrytols

Composition (% by weight)	Cast Density (g/cc)	Pressed* Density (g/cc)	MW	Oxygen Balance (to CO ₂)	MP(°C)
80/20 Tetryl/TNT ^(a)	1.51	—	274	-52	68
75/25 Tetryl/TNT	1.59	1.34	270	-54	68
70/30 Tetryl/TNT ^(b)	1.60 ^(c)	1.36	266	-55	68
65/35 Tetryl/TNT	1.60	1.38	264	-56	68

*Material passing thru No 100 sieve, pressed at 3000psi

(a) Not common

(b) Most common in military applications

(c) Voidless density is 1.71g/cc (Ref 5)

All of the above measurements were made with cast charges. For pressed charges of 70/30 Tetrytol in 1-5/8" diam, 12-15" long dimensions, $D=7.50\text{km/sec}$ at $d=1.63\text{g/cc}$ (Ref 5). This value is somewhat higher than that given in Ref 7. There is insufficient information as to whether this difference can be ascribed to the behavior of cast vs pressed charges

From Ref 5 one can obtain the following eqn: $D = 3.02 + 2.75\rho$ where D is in km/sec and the density ρ is in g/cc. The density range over which this eqn holds is not specified

Sensitivity:

There is no difference in the *impact* sensitivity of 65/35, 70/30 or 75/25 Tetrytol. All are less sensitive than Tetryl and more sensitive than TNT (Ref 3)

All Tetrytols are unaffected by the *Friction Pendulum Test* with either fiber or steel shoes (Ref 9)

In the *Rifle Bullet Test* (0.30 cal bullets fired into the open end of pipe-confined charges), Ref 9 gives the following results:

	Unaffected	Partials (%)
80/20 Tetrytol	80	20
75/25 Tetrytol	70	30
70/30 Tetrytol	45	55
65/35 Tetrytol	90	10

In a *wax gap test* (Ref 4), 75/25 Tetrytol is somewhat more sensitive than Comp B, but appreciably less sensitive than Pentolite

The following *minimum priming charge* data are taken from Ref 9:

	Lead Azide (gm)	Mercury Fulminate (gm)
80/20 Tetrytol	0.17	0.22
75/25 Tetrytol	0.19	0.23
70/30 Tetrytol	0.22	0.23
65/35 Tetrytol	0.23	0.23

For a priming charge of Diazodinitrophenol (DDNP) the minimum priming charges are: 0.19g for pressed 75/25 Tetrytol at $d=1.4\text{g/cc}$, and 0.31g for cast 75/25 Tetrytol (Ref 4)

Performance:

The *Ballistic Mortar Test* values of 75/25 and 70/30 Tetrytols are 122% and 120% TNT, respectively (Ref 9)

In the *Plate Dent Test* (Ref 9), the *brisance* of $d=1.66\text{g/cc}$ and 1.62g/cc 75/25 Tetrytol is 118% TNT and 114% TNT, respectively. 70/30 Tetrytol at 160g/cc has a *brisance* of 117% TNT

The *shaped charge* effectiveness of 70/30 Tetrytol at $d = 1.64\text{g/cc}$, as gaged in a const volume test (Ref 7), is appreciably lower than that of Comp B, Cyclotol and Comp A, all at roughly equiv packing densities. Cook's data (Ref 6) indicate that 60/40 Tetrytol is as efficient a shaped charge filler as 50/50 Pentolite and somewhat better than TNT. According to Ref 9, both 75/25 and 65/35 Tetrytols are about 1.2- to 1.25-fold more effective shaped charge fillers than TNT

Written by J. ROTH

Refs: 1) C.A. Taylor & W.H. Rinkenbach, I&EC **15**, 280 (1923) 2) L.S. Wise, "Study of Fundamental Properties of High Explosives", PATR **1466** (1945) 3) S. Livingston & W.H. Rinkenbach, "Characteristics of Tetrytols", PATR **1500** (1945) 4) Anon, NOL Rept **1111** (1952), 7-11 5) Anon, NAVORD Rept **2986** (1955) 6) Cook (1958), 236 & 237 7) D. Price, ChemRevs **59**, 815 (1959) 8) N.E. Beach & V.K. Canfield, "Compatibility of Explosives with Polymers (II)", PLASTECH Rept **33**, PicArsn (1968), 61 9) Anon, Engrg-DesHndbk, "Explosives Series, Properties of Explosives of Military Interest", AMCP **706-177** (1971), 341-47 10) M.M. Swisdak, NSCW **TR-75-116**, NavSurfWpnCenter, Silver Spring (1975), 28

Teutonite. A modification of Augendre Powder, described in Vol 1, A507-L

TEX. A designation for 1,5-Diacetoxy-1,3,5-trimethylene-2,4-dinitramine. See in Vol 5, D1118-L

Texas City Disaster. See under "Ammonium Nitrate Explosions, Fires and Hazards" in Vol 1, A359-L to A362-L

TFENA. Trifluoroethylnitramine (USA). See "TFEt Tetryl" which follows

TFEt Tetryl (2,4,6-Trinitrophenyl- β,β,β -Trifluoroethylnitramine, or β,β,β -Trifluoro Ethyl Tetryl). $(\text{NO}_2)_3\text{C}_6\text{H}_2\text{N}(\text{NO}_2)\text{CH}_2\text{CF}_3$; mw 355.152; N 19.72%; OB to CO_2 -45.05%; blocky white ndls which turn yel in light; mp 115.8-117°; bp, DTA shows a 2-stage decompn, 187-97° and 317-19°; (loading) d 1.62 to 1.69 g/cc. Sol in hot trichloroethylene. Prepn is by nitration of 2,4,6-trinitrophenyl- β,β,β -trifluoroethylamine with mixed acid at from 5° to RT. The product is pptd by pouring onto ice and then recrystd from trichloroethylene. The yield is 92.9% of theory

TFEt Tetryl has a booster sensy of 0.280g LA (<TNT); brisance by sand test 47.6g (110.7% TNT); closed cup expln temp of 250° and open cup expl temp of 302°; friction pendulum result of zero explns using a steel shoe; Q_c of -856.14kcal/mole (Parr bomb) and -869.01kcal/mole (rotating bomb); Q_e of 877.0 cal/g or 311.46kcal/mole (Parr bomb); Q_f of -149.56kcal/mole; a wt gain at 30° and 90% RH of 0.13%; impact sensy of $17 \pm 1.10''$ (50% pt using a PicArSn appar with a 2kg wt—Ref 3) and $56''$ (using a Bruceton machine with a 5kg wt where TNT is less than $56''$ —Ref 2); power by BalMort of 123.0% TNT, and by Trauzl test of 143.8% TNT; sensy to initiation of "no explns" from static electricity using a 2000 picofd condenser at 23000 kilovolts or 0.53J; 100° heat test result of 1.81% loss during the first 48 hrs and 1.50% loss during the second 48 hrs; vac stab test at 100° of 4.57cc/g/40 hrs, and at 120° of 11 plus cc/g/15 hrs; vel of deton 7253.4 m/sec at d 1.674g/cc, 7092.5m/sec at d 1.623 g/cc and 7335.0m/sec at d 1.690g/cc

See also under "Ethyl Tetryl" in Vol 6, E207-L

Refs: 1) Beil, not found 2) D.N. Thatcher & G.A. Noddin, "Bulk Synthesis of Fluorochemicals", Tech Documentary Rept **ATL-RDR-64-19**, E.I. DuPont de Nemours Co, Gibbstown, Contract No AF-08 (635)-2965 (1964) 3) H.J. Jackson et al, "A Comparative Evaluation of Selected Fluoroexplosives (U)", **PATR 3941** (1971)

TGSM. Acronym for **Terminally Guided Sub-Missile**. US concept, currently in exploratory development, to achieve an effective indirect

fire capability for destroying tanks. Whereas most other anti-tank weapons are line-of-sight weapons, the TGSM offers an indirect-fire option to a force commander, enabling him to engage reinforcements to the rear of enemy formations

A dispensing rocket or missile is launched with a warhead containing six or nine submissiles. An expl charge breaks open the warhead skin and the airflow provides sufficient force to catapult the submissiles away from the delivery vehicle and disperse them over the target area. Each submissile has a balloon parachute system to decelerate, stabilize and orient it. Four tailfins then open out and the balloon parachute is ejected. Each submissile contains a guidance system and seeker which independently searches for a target. When the target is acquired, the guidance system locks to it and guides the submissile in unpowered flight using the movable tailfins for control

The target acquisition system is likely to use an IR detector tuned to the typical emission spectrum of armored vehicles. It is understood, however, that a mm-band radiometric correlator is also being considered, the latter having the advantage of being less affected by environmental conditions than an IR system

The submissile warheads are HE anti-armor, but other warheads are possible

Refs: 1) M.J.H. Taylor & J.W.R. Taylor, Eds, "Missiles of the World", Charles Scribner's Sons, NY (1976), 148 2) R.T. Pretty, Ed, "Jane's Weapon Systems-1977", Franklin Watts, NY (1976), 46-47

Thallium, Its Salts and Organic Derivatives

Thallium. Tl; at w 204.37; at no 81; valence 1, 3; natural isotopes: 203 (29.50%) and 205 (70.50%); artificial radioactive isotopes: 191-202, 204 and 206-210; bluish-white, v soft, inelastic, easily fusible, heavy metal, leaves a streak on paper; oxidizes superficially in air at RT forming a grey coating of Tl_2O ; mp 303.5°; bp 1457°; d 11.85g/cc. Sol in nitric and sulfuric acids; insol in w, but readily forms sol compds when exposed to air and w. CA Registry No [7440-28-0]. Occurs in crooksite, (Cu, Tl, Ag)₂Se, found in Sweden; in lorandite, TlAgS_2 ,

found in Greece; and in hutchinsonite, (Tl, Cu, Ag)₂S, PbS, 2As₂S₃, found in Switzerland. Occurrence in the earth's crust is 0.7ppm. Prepn usually involves flue dusts from Pb and Zn smelting which are treated by electrolysis, pptn or redn to obtn the metal

Tl is toxic causing nausea, vomiting, diarrhea, weakness, coma, convulsions and death. Max tolerance level for w-sol salts in air is 0.1mg/m³ of air. Tl salts are used as rodenticides

The expl salts of Tl are shown below

Refs: 1) Gmelin, Syst Nr 38, Lief 2 (1940)
2) G. Brauer, "Hdbk of Preparative Inorganic Chemistry", Vol 1, 2nd Edn, Academic Press, NY (1963), 867-68 3) Sax (1968), 1154
4) Merck (1976), 1193 (No8970) 5) Cond-ChemDict (1977), 853

Thallium Azide. See in Vol 1, A631-R and the following *Addnl Refs*: 1) H. Rosenwasser, "Microscopic Examination of Thallium Azide Crystals", **USAERDL 1642-RR**, Ft Belvoir (1960) [The author reports that nucleation of TlN₃ acicular crystals leads to the formation of pyramidal faces, resulting in a whisker appearance. Also, that crystals of TlN₃ have been prepd in a matrix of KN₃] 2) H.D. Fair & R.F. Walker, Eds, "Energetic Materials-1, Physical Chemistry of the Inorganic Azides", Plenum Press, NY (1977) [Circa 1977 information on the physical, chemical and energetic properties of Thallium (I) Azide (pp 66-67 & 94); "Structural and Thermodynamic Details" (pp 167-70); "Role of Liberation Modes" (pp 170-72); "Transition Dynamics" (pp 172-73) and "Electron Spin Resonance of Defects in Tl azide"]

Bis (Chloromethyl) Thallium Chloride. See in Vol 2, B139-L

Thalliumdiethyl Chromate. (C₂H₅)Tl⁺CrO₄⁻ + Tl(C₂H₅)₂; C₈H₂₀O₄CrTl₂; mw 641.02; brilliant yel plates; mp, explds violently above 193°. V sol in ethanol and w; sol in eth. Prepn is by reacting aq Tl diethyl iodide with Ag chromate
Ref: A.E. Goddard, JCS **119**, 672-76 (1921) & CA **15**, 2416 (1921)

Thallium Diethyl-4:6-Dinitro-2-Amino Phenoxide.

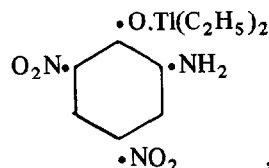

, C₁₀H₁₄O₅N₃Tl; mw 460.51; N 9.13%; small, carmine red plates with a metallic luster; mp 159° (decompn). Moderately sol in acet, ethanol and pyridine, sl sol in chl, eth and toluene; insol in carbon tetrachloride and lt petr. Prepn is by reacting an aq soln of Tl diethyl hydroxide with picramic acid, and then evapg the soln to dryness. The product is crystd from ethanol. The phenoxide explds violently when moistened with fuming nitric acid

Ref: A. Goddard, JCS **119**, 1310-15 (1921) & CA **15**, 3635 (1921)

Thallium Diethyl-4-Nitro-m-Tolyloxide.

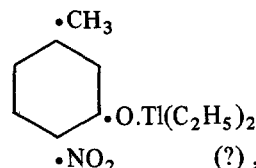

(?), C₁₁H₁₆O₃N₁Tl; mw 414.52; N 3.38%; pale red plates; mp, darkens at 220° and explds violently at 228°. Sol in chl, carbon tetrachloride & toluene; insol in lt petr. Prepn is by reacting an aq soln of Tl diethyl hydroxide with 4-nitro-m-cresol

Ref: A. Goddard, JCS **119**, 1310-15 (1921) & CA **15**, 3635 (1921)

Thallium Diethyl Picramate. See in Vol 1, A243-L

Thallium Dimethyl-p-Nitrophenoxide.

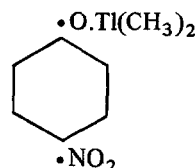

, C₁₀H₁₀O₃N₁Tl; mw 400.49; N 3.50%; yel plates; mp, darkens at 273° and explds violently at 275°. V sol in pyridine, sol in acet and eth; insol in other org solvents. Prepn is by reacting an aq soln of Tl-dimethyl hydroxide with p-nitrophenoxide

Ref: A. Goddard, JCS **119**, 1310-15 (1921) & CA **15**, 3635 (1921)

Thallium Dimethyl Picramate. See in Vol 1, A243-L

Thallium-2,5-Dinitrophenol (or Thallium γ -dinitrophenol).

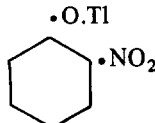
 $\cdot\text{O.Tl}$, $\text{C}_6\text{H}_3(\text{NO}_2)_2\text{O Tl}$; mw 387.48; N 7.23%; OB to CO_2 -35.099%; dk red leaflets; mp, explds on heating over 250° . Sol in w. Prepn is by the reaction of a soln of 2g of 2,5-dinitrophenol in 10% aq ethanol with 100ml of a 2.5% soln of Tl carbonate in acet at RT. After allowing the mixt to stand for 48 hrs at RT the cryst product is filtered off. The yield is 3.2g. The phenol puffs off v strongly when heated in a Bunsen flame and emits a bright green flame

Refs: 1) Beil 6, [867] 2) R. Langhans, SS 31, 2008 (1937)

Thallium Hexanitrodiphenylamine.

$(\text{NO}_3)_3\text{C}_6\text{H}_4\cdot\text{NH}(\text{Tl})\cdot\text{C}_6\text{H}_4(\text{NO}_3)_3$; $\text{C}_{12}\text{H}_5\text{N}_7\text{O}_{12}\text{Tl}$; N 15.24%; OB to CO_2 -36.05%; dk red ndles; mp, explds when heated over 250° . Sol in w. Prepn is by reacting an aq soln of 10g of Hexanitrodiphenylamine with a 2.5% acet soln of Tl

carbonate at RT. The mixt is then allowed to stand for 24 hrs at RT, and then the cryst product filtered off. The yield is 84%. The amine explds with brisance in a Bunsen flame and emits a bright green flame

Refs: 1) Beil, not found 2) R. Langhans, SS 31, 402-04 (1936) & CA 31, 2008 (1937)

Thallium MEDNA. See in Vol 8, M54-L under "MEDNA . . ."

Thallium Picrate (or the Thallium salt of 2,4,6-Trinitrophenol).

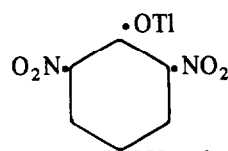

Prepn is by reacting a 20% concn of Picric Acid in methanol with a 2.5% soln of Tl carbonate in acet and then filtering off the dk red cryst formed. According to Langhans (Ref 3), the yel enantirope is obtained by drying the red cryst to 100° at atm press; under vac the transition

Table 1
Properties of the Thallium Picrate Enantiotropes

Color and Cryst Form	Transition pt, $^\circ\text{C}$	Melting pt, $^\circ\text{C}$	Density, g/cc	Solvent Solubilities				Expln Temp, $^\circ\text{C}$	Specific Heat, cal/ $^\circ$ between 0-19 $^\circ\text{C}$
				Methanol		Water			
				Temp, $^\circ\text{C}$	g/l	Temp, $^\circ\text{C}$	g/l		
Red Monoclinic Sphenoids	on standing; 46°	260	3.164 at 17°	0	1.35	0	3.91	284-295	0.137
	(stable below 46° Ref 1)			47	11.41	47	12.60		
Yellow Triclinic Sphenoids	on standing; 46°	\sim 260	2.993 at 17°	45	11.96	45	10.41	290-295	0.134
	(stable above 46° Ref 1)			65	18.42	70	24.33		

occurs at 90° in 80% yield with 0.5% w of crystn. Both enantiotropes expld on heating or impact

Refs: 1) Beil **6**, 277, (135) & {882} 2) O. Silberrad & H.A. Phillips, JCS **93**, 484 (1908) 3) R. Langhans, SS**31**, 359–62, 402–04 (1936) & CA **31**, 2008 (1937)

Thalious Azidodithiocarbonate. See in Vol **1**, A637-L

Thalious-Thallic Azide. See in Vol **1**, A623-R

Thawing of Dynamite. See in Vol **5**, D1588-R and D1596-L & R

Theodorovic. A Viennese who patented [BritP No 949 (1896)] proplnts prepd by blending NC, previously gelatinized with amyl acetate, with a nitrate and charcoal

Ref: Daniel (1902), 765

Theoretical Calculations for Energetic Materials. See under “Thermochemistry” and “Thermodynamics” in this Vol

Theories of Explosive (or Detonative) Reaction. See in Vol **6**, E441-R to E-442-R. Also, in Vol **7** under “Kinetics in Explosion Phenomena”, K6-R to K13-L; “Ionization in Detonation and Shock Waves”, I128-L to I132-L; “Initiation”, I106-L to I109-L; “Ignition”, I11-L to I30-R; and “Hugoniots”, H179-L to H185-L. In this Vol, see under “Shock Sensitivity of Explosives”

Thermal Analysis, Application of. See in Vol **5**, D1255–R to D1256-R. Also, in this Vol, see under “Safety in the Energetic Materials Field” (section on thermoanalytical procedures), and “Thermochemistry”

Thermal Conductivity of Explosives. See in Vol **3**, C498-L and under “Heat Conductivity Coefficients and Specific Heats of Common

Explosives” (Table 4) in Vol **7**, H45 to H46

Thermal Effects of Impact. See under “Impact, Initiation of Explosion by” in Vol **7**, I35-L ff

Thermal Expansion, Coefficient of. See in Vol **6**, E350-R for definition

Table 1, taken from the ref, lists the measured linear (α) and cubic (β) expansion coefficients of expls and binders along with their glass transition temps and pressed densities. The cubic expansion coefficients (β) can be calcd for isotropic materials as $\beta = 3\alpha$

Ref: B.M. Dobratz, “Properties of Chemical Explosives and Explosive Simulants”, UCRL-**51319**, Rev 1 (1974), 6-4 to 6-5

Table 1
Explosives and Binders: Coefficients of Thermal Expansion CTE,
Glass Transition Temperatures T_g, and Pressed Densities

	Linear CTE (α) ^a			Cubic CTE (β) ^a		T _g		Pressed Density (g/cm ³ or Mg/m ³)	
	(10 ⁻⁶ in/in-°F)	(10 ⁻⁶ cm/cm-°C or $\mu\text{m/m-K}$)	T (°F or °C)	(K)	(10 ⁻⁶ cm/cm-°C or $\mu\text{m/m-K}$)	T (°C (K))	(°F)		(K)
Explosives									
Baratol	—	33 + 0.26T	-40 to 60°C	(233–333)	—	—	—	—	—
Boracitol	—	46.7	0 to 60°C	(273–333)	—	—	—	—	—
Comp B-3	—	54.6	6 to 25°C	(279–298)	—	—	—	—	—
Comp B-3	—	97.5	27 to 63°C	(300–336)	—	—	—	—	—
DATB	—	32–46	-20°C	(253)	—	—	—	—	—
DATB	—	52–66	85°C	(359)	—	—	—	—	—
DOP	—	74	10 to 40°C	(283–313)	—	—	—	—	—
Estane 5702-F1	—	—	—	—	—	—	-31°C	(242)	—
HMX	—	50.4	-53.9 to 73.9°C	(219–347)	162.5	-30 to 70	None	—	—
HMX	22.0	—	-65 to 165°F	(219–347)	—	(243–343)	—	—	—
HNAB	—	80	—	—	—	—	—	—	—
HNS	—	92	—	—	—	—	—	—	—
Kel-F-3700	—	—	—	—	—	—	-51°C	(258)	—
LX-02	—	128.7	-20 to 50°C	(244–253)	385	-30 to 70	None above	—	—
LX-02	—	—	—	—	—	(243–343)	-4	(253)	—
LX-04	28.5	(51.3)	-65 to -18°F	(219–245)	228.2	-30 to 70	-18	(245)	1.860–1.870
LX-04	39.5	(71.1)	-18 to 165°F	(245–347)	—	(243–343)	—	—	—
LX-07	26.7	(48)	-65 to -18°F	(219–245)	182.9	-30 to 70	-18	(245)	1.860–1.870
LX-07	34.8	(63)	-18 to 165°F	(245–347)	—	(243–343)	—	—	—
LX-08	104.5	(188)	—	—	565	—	—	—	—
LX-09	27.1	(48.8)	-65 to -20°F	(219–244)	—	—	-20	(244)	1.835–1.845
LX-09	31.0	(55.8)	-20 to 165°F	(244–347)	—	—	—	—	—

(continued)

Table 1 (continuation)

	(10 ⁻⁶ in/in-°F)	Linear CTE (α) ^a			Cubic CTE (β) ^a			T _g		Pressed Density (g/cm ³ or Mg/m ³)
		(10 ⁻⁶ cm/cm-°C or $\mu\text{m}/\text{m}\cdot\text{K}$)	T (°F or °C)	(K)	(10 ⁻⁶ cm/cm-°C or $\mu\text{m}/\text{m}\cdot\text{K}$)	T (°C (K))	(°F)	(K)		
Explosives										
LX-10	24.8	(44.6)	-65 to 0°F	(219-255)	-	-	-18	(245)	-	
LX-10	26.2	(47.0)	0 to 165°F	(255-347)	-	-	-	-	-	
LX-11	31 est	(56)	-65 to -10°F	(219-249)	-	-	-18	(245)	-	
LX-11	46 est	(83)	10 to 165°F	(261-347)	-	-	-	-	-	
LX-14	27	(48.5)	<30°F	(<243)	-	-	-	-	-	
LX-14	31	(55.8)	>30°F	(>243)	-	-	-	-	-	
NC (12.7% N)	-	80-120	-	-	-	-	-	-	-	
PBX-9010	-	66	-	-	-	-	-	-	-	
PBX-9011	28.7	(51.7)	-65 to -40°F	(219-233)	-	-	-35	(236)	-	
PBX-9011	37.3	(67.1)	-30 to 165°F	(243-347)	-	-	-	-	-	
PBX-9404	28.1	(50.6)	-65 to -30°F	(219-239)	-	-	-29	(239)	1.828-1.842	
PBX-9404	32.2	(58.0)	-10 to 165°F	(250-347)	-	-	-	-	-	
PBX-9501	30.6	(55.1)	-80 to 160°F	(211-344)	-	-	-	-	-	
PETN	46.1	(83.0)	-	-	249.2	-30 to 70 (243-343)	None	-	-	
PETN	-	76.5-89.9	20 to 90°C	(244-363)	-	-	-	-	-	
Polystyrene	-	60-80	<100°C	(<373)	170-210	<100°C (<373)	100°C	(373)	-	
Polystyrene	-	-	-	-	510-600	>100°C (>373)	-	-	-	
RDX	-	63.6	20°C	(244)	191	20(244)	-	-	-	
Sylgard 182	180.0	(324)	-65 to 165°F	(219-347)	-	-	-	-	-	
TEF	-	-	-	-	840	-	-	-	-	
TNT	-	50.0 + 0.007T	Below m.p.	-	-	-	-	-	-	
Viton A	65.0	(117)	Below -6°F	Below 252	-450	Below -20(253)	-27°C	(246)	1.819	
Viton A	145.2	(254.8)	-6 to 165°F	(252-347)	728	-20 to 70 (253-343)	-	-	-	
XTX-8003	68.8	(123.8)	-22 to 158°F	(243-343)	413.7	-53.9 to 73.9	-	-	1.544	
XTX-8003	77	(139)	75 to 150°F	(297-339)	-	(219-296)	-	-	-	

Thermal Explosion

1.0 General Characteristics

If the heat generation in an exothermic reaction exceeds the heat loss of the system a *runaway reaction* will occur. This runaway reaction is commonly called a *thermal expln*, even though the manifestation of the runaway reaction can be a fire rather than an expln. Obviously the general subject of thermal explns is of great practical importance to expl safety and it also plays a very important role in the theoretical treatment of the initiation behavior of expls

The qual rationale for thermal explns is quite simple. Chemical reaction rates (which control heat generation in *exothermic* reactions) increase exponentially with temp (see Vol 7 article on "Kinetics", K11-L to K13-L), whereas heat loss rates increase only linearly with temp. As temp increases, the exponential dependence of heat generation on temp will invariably lead to a stage where the rate of heat generation

exceeds the rate of heat loss and thermal expln becomes inevitable. This is illustrated in the sketch shown in Fig 1 (from Ref 19) for the hypothetical exptl arrangement shown in Fig 2. The abscissa of Fig 1 is labeled "expl temp", but in the general context it is the temp of the reacting material, which need not be an "expl" in the usually accepted connotation of expls. The straight lines in Fig 1 are heat loss rates for three different "bath" temps in which the "expl" is immersed. The curve in Fig 1 is the exothermic chemical reaction of the heated material. For a bath temp (T_0) of 200° , the heat loss curve intersects the heat generation curve at point A, where heat loss rate and heat generation rate are equal. The physical significance of this intersection is that the temp of the heated material will be stabilized at a temp corresponding to the abscissa of point A or about 202° in our example. The second intersection has no physical reality since the temp of the system is stabilized. At a higher bath temp ($T_0 = 208^\circ$ in Fig 1), the heat loss curve touches the heat generation curve at a *single point* (the

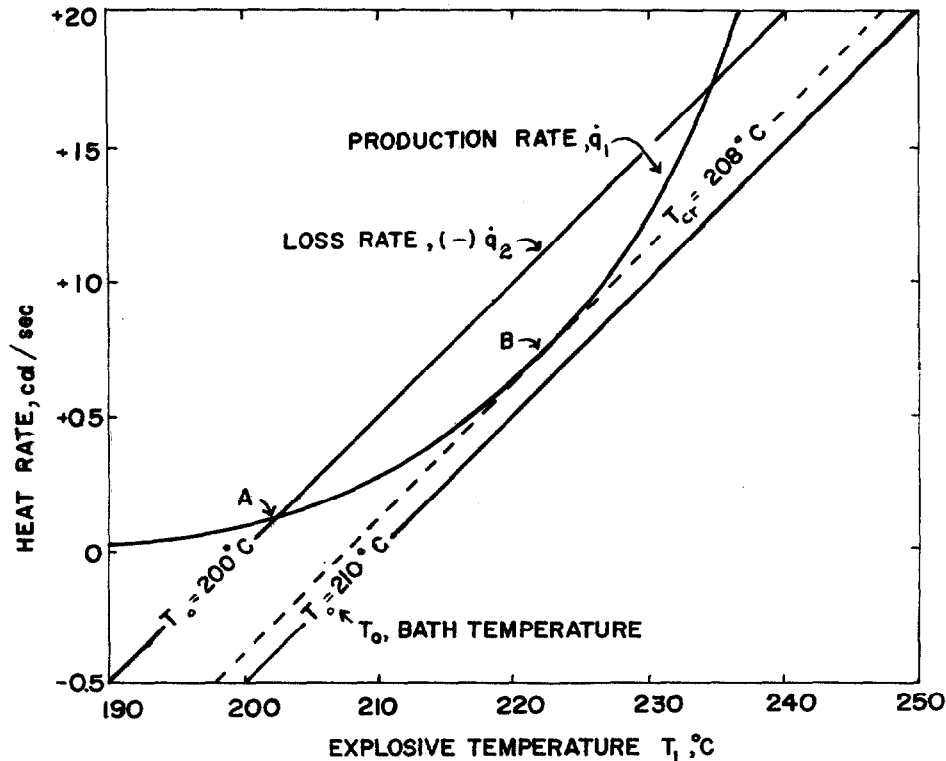

Fig 1 Heat Production and Heat Loss Rates in an Experiment of the Type Depicted in Fig 2

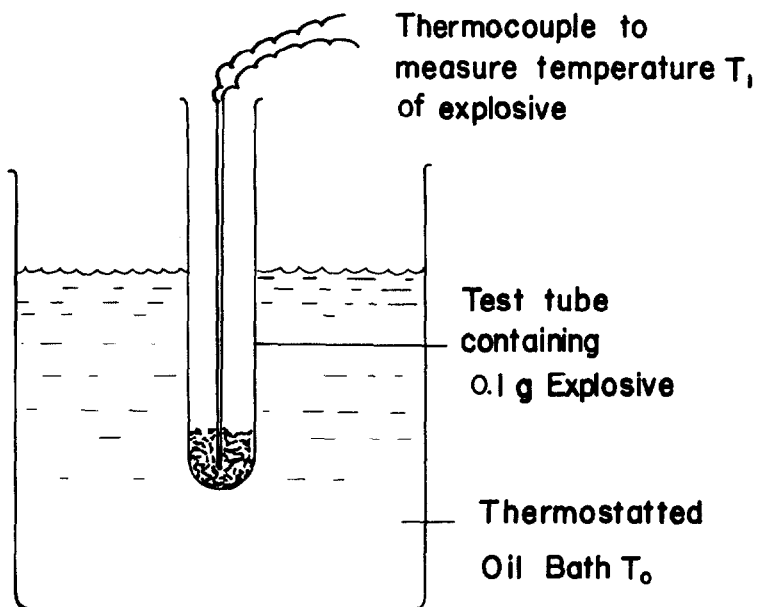

Fig 2 An Experiment to Illustrate the Critical Nature of a Thermal Explosion

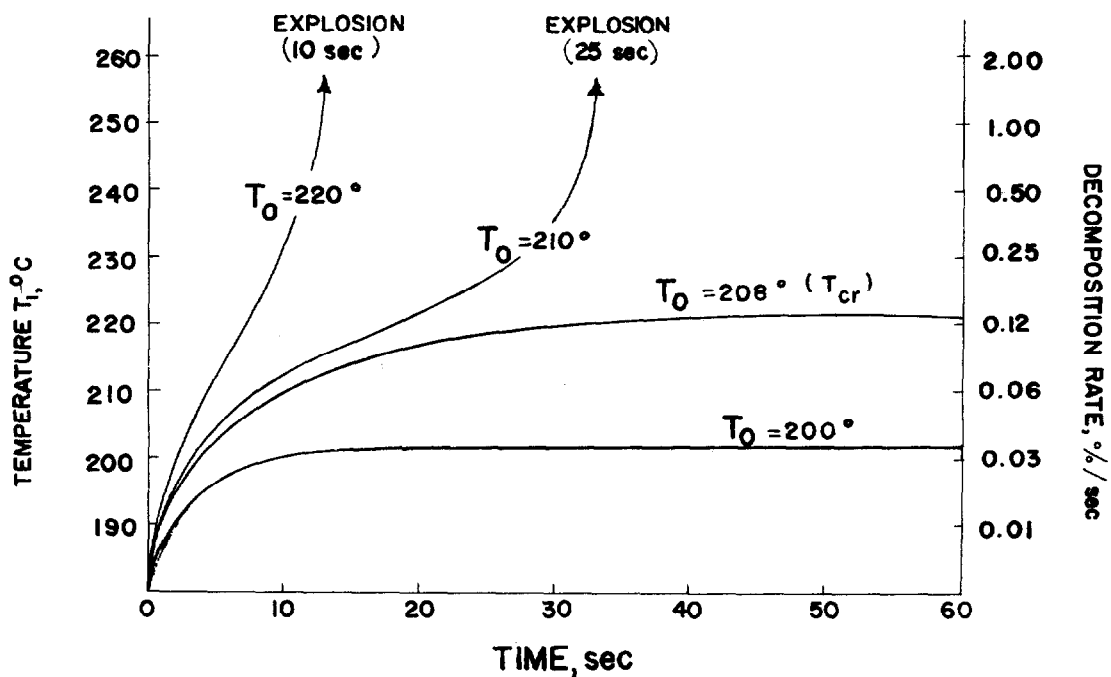

Fig 3 Heating Curves (Temperatures vs Time) in an Experiment of the Type Depicted in Fig 2 and Consistent With the Data in Fig 1

point of tangency at B). The abscissa value of point B is about 221°. This temp of 221° is the highest temp to which the material of the example can be subjected without undergoing thermal expln. For the particular system of the example, 221° is the *critical temp* of the material heated under the conditions shown in Fig 2. It should be emphasized that under different heating conditions this same material can have a critical temp which is different from 221°. A bath temp of 210° (the bottom straight line in Fig 1) exceeds the critical temp, and the material will undergo thermal expln. Incidentally, for a perfectly insulated system (no heat loss), we would, in principle, expect an exothermic reaction to undergo thermal expln *eventually* even at very low bath temp

The data of Fig 1 can be depicted as material temp vs time plots. This is done in Fig 3. Note that, as expected, T_1 reaches asymptotic values for $T_0 \leq 208^\circ$, whereas T_1 increases in an expln fashion for $T_0 > 208^\circ$. Also note that the times at which T_1 starts to increase rapidly decrease as T_0 increases. The righthand ordinate of Fig 3 depicts the decompn rate of the reacting material. Note that this rate is quite low. Indeed for reactions that are relatively exothermic and have a fairly high energy of activation (see Vol 7 article on "Kinetics"), most materials rarely undergo more than a few percent decompn before they "expld". It is also noteworthy (and indeed characteristic of most thermal explns) that the inflection points (the temp at which the curves "pause" before the rapid rise in temp) are quite close to the critical temp

2.0 Quantitative Treatment of Thermal Explosions

2.1 General Solution

Here we will consider only solid reacting materials, so that we can neglect convective heat losses. With this restriction we only need to equate the *self-heating* of the system to the algebraic sum of heat loss from the system and heat generation by the system. This is done in Eq 1:

$$\underbrace{\rho c \left(\frac{\partial T}{\partial t} \right)}_{\text{self-heating}} = \underbrace{\lambda \nabla^2 R}_{\text{heat loss by conduction}} + \underbrace{\rho Q \left(\frac{d\epsilon}{dt} \right)}_{\text{production of heat by chemical reaction}} \quad (1)$$

where:

- T = solid temp, °K
- c = specific heat, cal/g-°K
- ρ = density, g/cm³
- λ = thermal conductivity which is assumed temp independent, cal/cm-°K-sec
- Q = heat of reaction, cal/g
- ϵ = fraction of expl reacted, dimensionless
- ∇^2 = Laplacian operator, which in Cartesian space coordinates x, y, z is

$$\nabla^2 = \frac{\partial^2}{\partial x^2} + \frac{\partial^2}{\partial y^2} + \frac{\partial^2}{\partial z^2}$$

We further restrict our treatment to symmetric expl geometries for which heat conduction depends on a single space coordinate so that:

$$\nabla^2 = \frac{\partial^2}{\partial x^2} + \frac{\ell}{x} \left(\frac{\partial}{\partial x} \right) \quad (2)$$

where $\ell=0, 1, \text{ or } 2$ for planar, cylindrical, or spherical symmetry and x now refers to the appropriate *single* space coordinate

The term $d\epsilon/dt$ according to chemical reaction rate theory is:

$$\frac{d}{dt} = (1-\epsilon)^n k_r = (1-\epsilon)^n Z \exp [-E/(RT)] \quad (3)$$

where n is the reaction order and k_r the reaction rate constant is replaced by its Arrhenius form with E=activation energy and Z=frequency factor (see Vol 7 article on "Kinetics")

With the above formulations, Eq 1 becomes:

$$\rho c \left(\frac{\partial T}{\partial t} \right) = \lambda \left[\frac{\partial^2 T}{\partial x^2 a} + \frac{\ell}{x} \left(\frac{\partial T}{\partial x} \right) \right] + \rho Q (1-\epsilon)^n Z \exp [-E/(RT)], \quad (4)$$

where a is characteristic dimension

Unfortunately there are no exact analytical solutions to Eq 4 under any boundary conditions because of the nonlinearity introduced by the exponential chemical reaction term. Thus it becomes necessary to seek approximate solutions and/or restrict conditions even further than was done above

The remainder of this article will be devoted to describing some of these approximate solutions and applying them to problems of interest to expl technology. At this stage, even without further elaboration, it is quite clear from Eq 4 that the controlling variables in a thermal expl are:

- (1) Activation energy
- (2) Heat of reaction
- (3) Thermal conductivity and heat capacity

- (4) Effective heated surface area
 (5) Mass of explosive

In what follows, we will be examining the action and interaction of these variables on the incidence of thermal expln

Before examining various approximate solutions of Eq 4 for conditions of special interest, it is convenient to write Eq 4 in dimensionless form and to introduce some simplification. From the description of the thermal expln process given above, two reasonable approximations can be made which give rise to useful solutions. The approximations are:

- (1) The temp T of the material just prior to expln is not too different from the initial expl temp T_0 , ie, $(T-T_0)/T_0 \ll 1$
 (2) The amount of reaction just prior to expln is slight so that the reaction is essentially zero-order, ie, $n=0$

With these assumptions, Eq 4 simplifies in the following manner: Denoting $T=T_0+\Delta T$, then:

$$\frac{E}{RT} = \frac{E}{RT_0} \left(\frac{1}{1+\Delta T/T_0} \right) \approx \frac{E}{RT_0} \left(1 - \frac{\Delta T}{T_0} \right) \quad (5)$$

With the following dimensionless temp and space variables:

$$\theta = \frac{E}{RT_0^2} (T-T_0)$$

$$\xi = x/a, \text{ Eq 4 becomes:}$$

$$\frac{\rho c a^2}{\lambda} \left(\frac{\partial \theta}{\partial t} \right) = \frac{\partial^2 \theta}{\partial \xi^2} + \frac{\ell}{\xi} \left(\frac{\partial \theta}{\partial \xi} \right) + \delta \exp[\theta] \quad (6)$$

where:

$$\delta = \frac{Q E a^2 \rho Z}{\lambda R T_0^2} \exp [-E/(RT_0)] \quad (7)$$

Here a is the characteristic dimension of the expl— for example, the one-half thickness of an expl slab ($\ell=0$), the radius of a long cylinder ($\ell=1$) or of a sphere ($\ell=2$)

2.2 Steady-state Condition $\partial T/\partial t=0$, and the

Concept of Critical Temperature and Size

Frank-Kamenetskii (Refs 1 & 4) and Chambré (Ref 2) examined the possible steady-state solutions to Eq 7 for $\partial \theta/\partial t=0$, and symmetrical heating of potentially expl materials, with boundary conditions of:

$$\xi = 0, \quad d\theta/d\xi = 0 \quad (\text{at the center})$$

$$\xi = 1, \quad \theta = 0 \quad (\text{at the surface})$$

For each of the three geometries ($\ell=0, 1, 2$), it was found that there is a max value of the

parameter δ for which steady-state solutions to Eq 7 are possible. This max value is designated δ_{cr} . For $\delta \leq \delta_{cr}$, steady-state solutions are possible; but for $\delta > \delta_{cr}$, a stationary temp distribution is impossible. It is, therefore, seen that δ_{cr} defines the critical conditions for thermal explns under uniform surface heating conditions. The values obtained in Refs 1, 2 & 4 for δ_{cr} and the corresponding max critical stationary temp distribution $\theta_{max,cr}$ are shown in Table 1

Table 1
Critical Values for Thermal Explosion
Parameters δ and θ

Explosive Geometry	δ_{cr}	$\theta_{max,cr}$
Infinite plane-parallel slab, $\ell=0$	0.88	1.20
Infinite long cylinder, $\ell=1$	2.00	1.39
Sphere, $\ell=2$	3.32	1.61

Now the critical expln temp T_{cr} is just that value of the surface temp T_0 of the material which results in $\delta = \delta_{cr}$ in Eq 7, namely:

$$T_{cr} = \frac{E/R}{\ell n \left(\frac{Q E a^2 \rho Z}{\lambda R T_{cr}^2 \delta_{cr}} \right)} \quad (8)$$

Similarly, there is a critical size of material a_{cr} for $\delta = \delta_{cr}$, or

$$a_{cr} = \left(\frac{\lambda R \delta_{cr}}{Q E \rho Z} \right)^{1/2} T_0 \exp [E/(2RT_0)] \quad (9)$$

Eqs (8) and (9) are of great practical value since they can be used to estimate conditions of temp and size at which exothermic reactions become explosively violent. Note, Eqs 8 and 9 show that the critical temp T_{cr} below which no explns are obtained is related to the rate at which heat can flow to the expl surface, which in turn is related to the surface/volume ratio of the expl geometry. Thus, for a given value of a , slabs will have the lowest T_{cr} , and spheres will have the highest T_{cr}

2.3 Adiabatic Explosion Time

For adiabatic self-heating (obtained for an infinitely reacting mass or a thermally isolated finite mass), $\nabla^2 T = 0$. Consequently the heat

conduction terms in Eqs 4 & 6 disappear and Eq 6 becomes:

$$\frac{d\theta}{dt} = \frac{QZE}{cRT_0^2} \exp[-E/(RT_0)] \exp[\theta] \quad (10)$$

or

$$\int_0^{t_e} dt = \frac{cRT_0^2}{QZE} \exp[E/(RT_0)] \int_{\theta_0}^{\theta_e} \exp[-\theta] d\theta$$

and

$$t_e = \frac{cRT_0^2}{QZE} \exp[E/(RT_0)] \exp[-\theta] \Big|_{\theta_0}^{\theta_e} \quad (11)$$

The expln time t_e is considered to be the time from the beginning of heating to the time at which rapid temp rise commences. The dimensionless temp θ_e is the temp at t_e

The integration limits on θ correspond to:

$$t = 0; \quad \theta_0 = 0$$

$$t = t_e; \quad \theta_e = \frac{E}{RT_0^2} (T_e - T_0)$$

However, it may be shown (Refs 2 or 4) that, within the approximations used in deriving Eq 6, $\theta_e \approx 1$. We can, therefore, express the expln time in Eq 11 as:

$$t_e \approx \frac{cRT_0^2}{QZE} \exp[E/(RT_0)] \quad (12)$$

Eq 12 is of the form of

$$\ln t_e = A + B/T$$

which is the relationship observed in most measurements of expln time

2.4 Numerical Solution of Thermal Explosion Equation

Zinn and Mader (Ref 6) obtained numerical solutions of Eq 4 (without special restrictions such as $\partial T/\partial t=0$ or $\nabla^2 T=0$) for a number of expls of various geometries. They divided the time scale into equal increments of τ seconds and assumed that no reaction takes place during τ but only at the end of each such increment. Thus the heat produced by the chemical reaction, $\rho Q d\epsilon/dt$, can be added in the form of an "instantaneous" temp correction to the temp $T(x,t)$ that is obtained during the interval τ . Eq 4 is then solved with $Q=0$ over each interval τ but with a different initial temp distribution $f_j(x)$ for each consecutive τ . Consequently, the initial temp distribution will be given by:

$$f_{j+1}(x) = T(x,j\tau) + \frac{Q}{c} (\Delta\epsilon_j)$$

$$\Delta\epsilon_j = \tau [1 - \epsilon(x,j\tau)]^n Z \exp$$

$$\left\{ -E/[RT(x,j\tau)] \right\}$$

$$\epsilon(x,j\tau) = \sum_j \Delta\epsilon_j$$

The numerical procedure is then as follows.

Start with $Q=0$. Solutions for $T=f(x,t)$ for this case are given by Carslaw & Jaeger (Ref 5).

These solutions may also involve numerical integration. For example, in a slab with $0 \leq x \leq 2a$, $Q=0$ and $Q=0$, Eq 4 becomes:

$$\rho c \left(\frac{\partial T}{\partial t} \right) = \lambda \left(\frac{\partial^2 T}{\partial x^2} \right)$$

and its solution (according to Ref 5) is:

$$T(x,t) = T_s + \left\{ \frac{1}{a} \sum_{n=1}^{\infty} \exp \left[-\frac{n^2 \pi^2 \lambda t}{4 \rho c a^2} \right] \right\}$$

$$X \left\{ \sin \left(\frac{n\pi x}{2a} \right) \int_0^{2a} \left[f_0(x) - T_s \right] \sin \left(\frac{n\pi x}{2a} \right) dx \right\}$$

where the integral is evaluated numerically.

Subsequently $f_0(x)$ is replaced by $f_j(x)$ and the temp distribution is evaluated for each consecutive time interval τ . The accuracy of this method depends on fineness of the increments τ and x

Fig 4 shows temp profiles (from Ref 6) for *RDX* spheres for several initial surface temps at times near the time to expln (t_e). The parameters used in the calcn are: $\rho=1.8\text{g/cm}^3$, $c=0.5\text{cal/g}\cdot^\circ\text{C}$, $\lambda=7 \times 10^{-4}\text{cal}/^\circ\text{C}\cdot\text{cm}\cdot\text{sec}$, $Q=500\text{cal/g}$, $Z=10^{18.5}\text{sec}^{-1}$, $E=47500\text{cal/mole}$. It is important to note that for a surface temp, T_s , only slightly greater than T_{cr} , the hottest regions are near the center of the sphere. As T_s is increased, the hottest regions shift toward the surface, and for $T_s \gg T_{cr}$ they are very close to the surface. Of course the implication of these observations is that thermal expln will occur first near the center if $T_s \geq T_{cr}$, and near the surface if $T_s \gg T_{cr}$

Explosion times for *RDX* slabs, cylinders and spheres are shown in Fig 5. Note that calcd expln times *do not* follow Arrhenius kinetics in

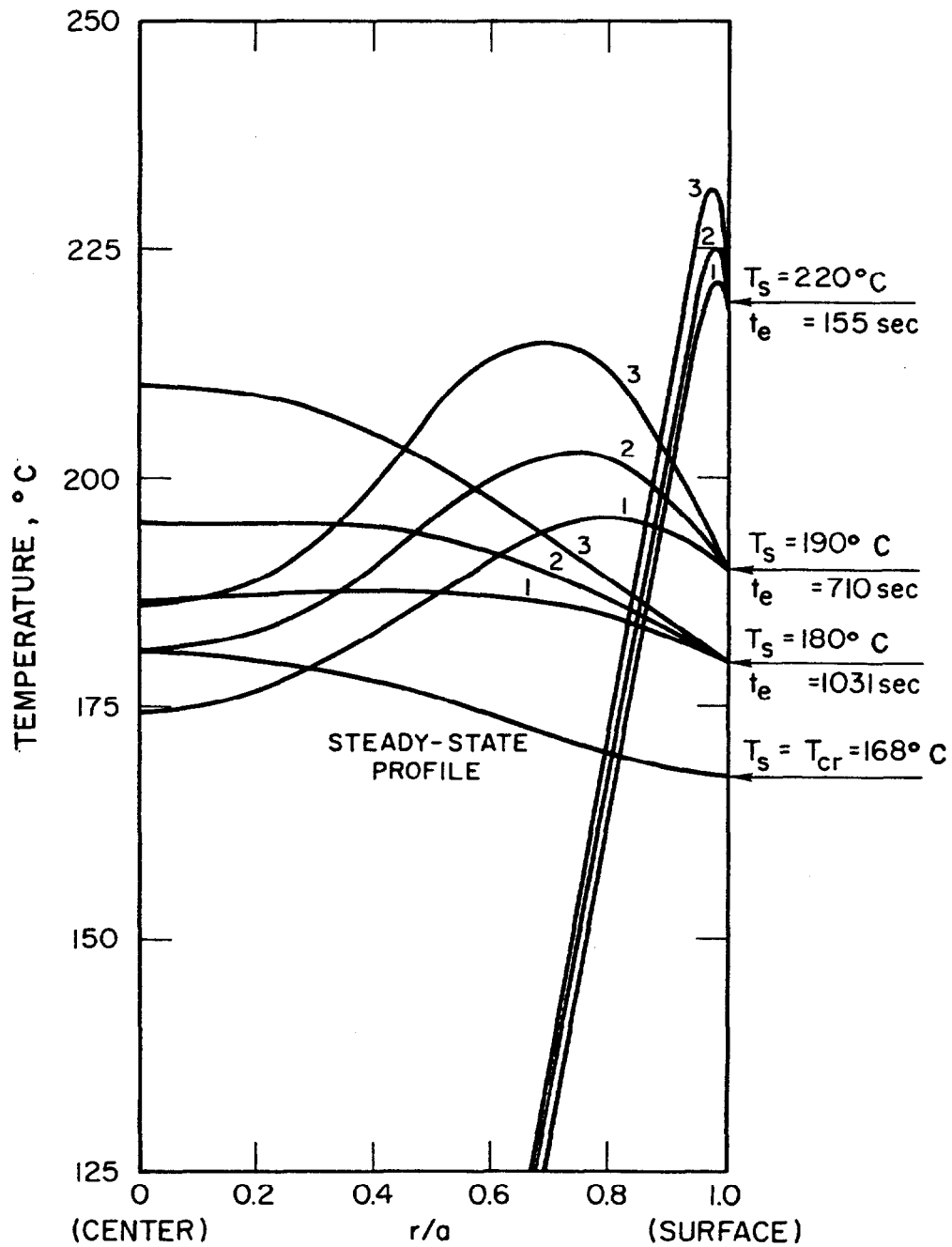

Fig 4 Temperature Profiles for Times Near the End of the Induction Period, as Calculated for 1-inch Spheres of RDX Initially at 25°C . [Curve 1: $t = 0.90t_e$; Curve 2: $t = 0.95t_e$; Curve 3: $t = 0.98t_e$. Also shown is the steady-state profile at the critical temp T_{cr} (Ref 6)]

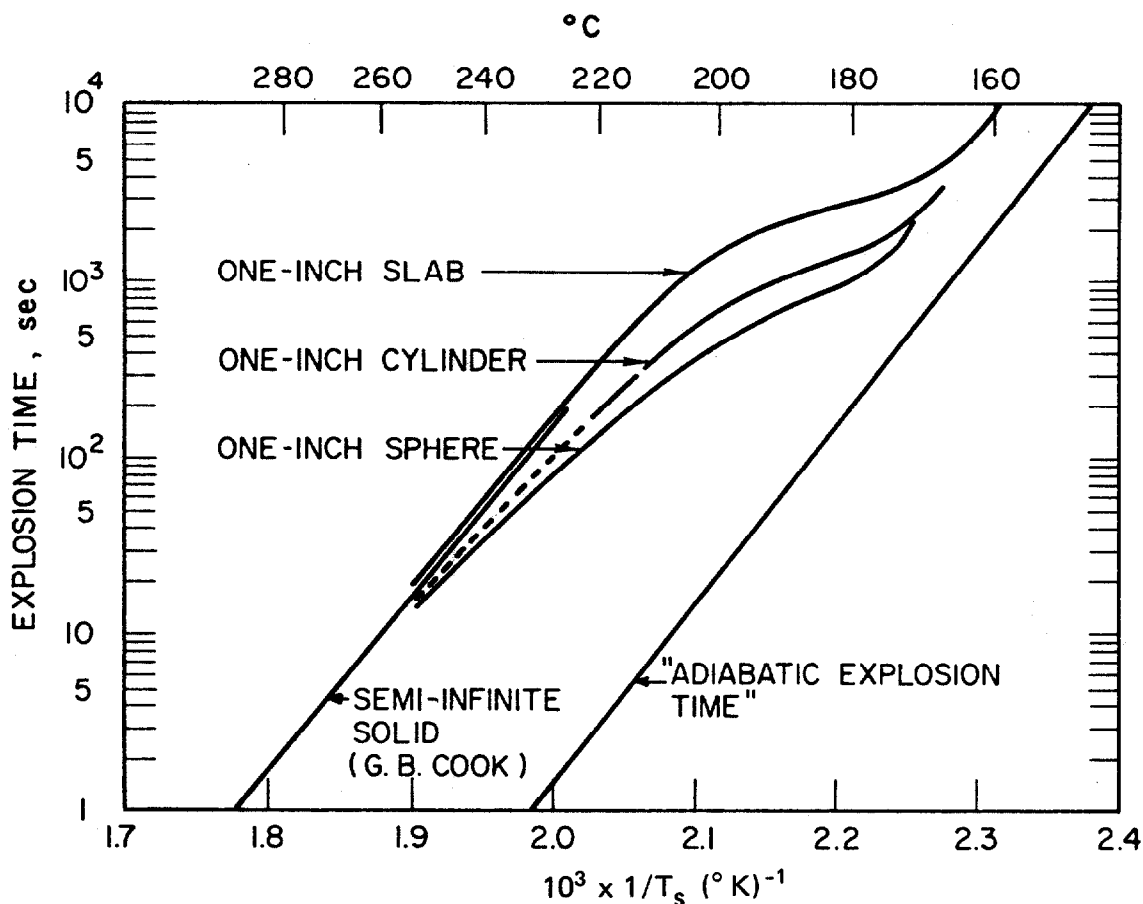

Fig 5 Explosion Times vs $1/T_s$ for RDX in Various Geometries, Initially at 25°C (Ref 6)

the same manner as adiabatic expln times. Thus one must be very cautious in identifying the slopes of measured expln times, T_e vs $1/T_s$, with an activation energy for the chemical reaction. Incidentally, the curve for the RDX cylinder is qualitatively similar to the curves obtained by Roth in his evaluation of the "Wenograd" test (Ref 12) *

Zinn & Mader (Ref 6) also found that t_e calcs for any expl could be generalized according to:

$$t_e = \frac{\rho c a^2}{\lambda} F(E/T_{cr} - E/T_s) \quad (13)$$

where F is a function which depends only on

* In the Wenograd test a liq expl is introduced into stainless steel hypodermic tubing which is then heated by a condenser discharge. The change in electrical resistance of the tubing is a measure of T_s and a further change in resistance upon expln is a measure of t_e

system geometry (slab, cylinder or sphere) and the initial temp T_0 . The variation of F in terms of the argument $(E/T_{cr} - E/T_s)$ is shown in Fig 6 for the three geometries all initially at 25°

Thus, t_e can be obtained for any material whose thermal and kinetic parameters are known

Roth's measurements for TNT in the Wenograd test (Ref 12) agree closely with calcs based on Fig 6 over the middle range of temps, but deviate (t_e faster than computed at low T_s , and t_e slower than computed at large T_s) from computed values in the low and high temp ranges. The parameters used in the computation were: $\lambda = 6 \times 10^{-4} \text{ cal}/^\circ\text{C-cm-sec}$; $\rho = 1.45 \text{ g/cc}$ (molten TNT); $c = 0.4 \text{ cal/g}$; $Q = 300 \text{ cal/g}$; $E = 41100 \text{ cal/mole}$; and $Z = 1.6 \times 10^{13} \text{ sec}^{-1}$. For expl columns of $9 \times 10^{-3} \text{ cm}$ radius and $19 \times 10^{-3} \text{ cm}$ radius, the computed T_{cr} 's were 670°K and 640°K respectively, in reasonable accord with observa-

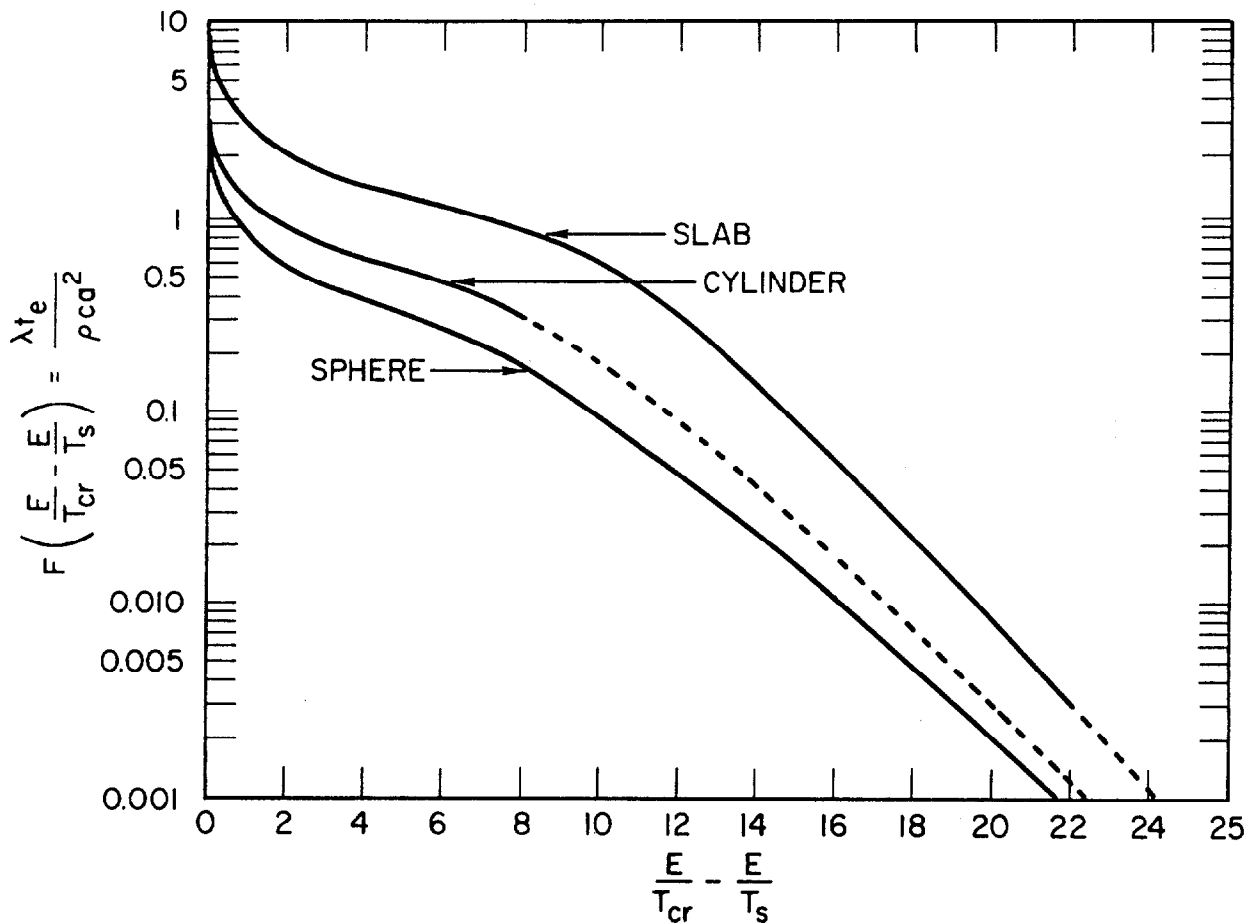

Fig 6 Graphs of $\lambda t_e / (\rho c a^2)$ vs $E/T_{cr} - E/T_s$ for Spheres, Cylinders, and Slabs, All Initially at 25°C (Ref 6)

tion. Similar computations for NG, EGDN and Petrin did not result in quant agreement with observation (Ref 12), but the observed t_e vs $1/T_s$ plots were qual similar to the computed plots (See Fig 5)

It is instructive to compare observed expln times, T_e , for TNT (Ref 12) (in the region where they agree with Zinn & Mader's numerical soln of Eq 4) with expln times, t_{ad} , calcd by Eq 12 (adiabatic conditions, $\Delta t T_s = 900^\circ K$, $t_e = 1.6$ msec, while $t_{ad} = 0.031$ msec; and for $T_s = 833^\circ K$, $t_e = 8.1$ msec, while $t_{ad} = 0.17$ msec. This example illustrates that adiabatic conditions are not realized in small-diameter expl columns. Consequently, use of Eq 12 for these conditions results in a large underestimate of the expln time

2.5 Thermal Explosion of Hot Spots

In sections 2.2 through 2.4 we have been examining the thermal expln of materials heated uniformly at their surface. These uniformly heated surfaces were assumed to be relatively large, eg, a semi-infinite slab or a long cylinder. Now we wish to consider the thermal expln of a very small hot region of material, ie, the thermal expln of a "hot spot". This subject, which is of great importance in the understanding of initiation of detonation, has already been treated in part in Vol 7, H170-L to H175-R. Below we will amplify that treatment and emphasize the critical conditions required to produce thermal expln in a hot spot

In essence a hot spot is a small volume of material at a considerably higher temp than its

surroundings. To be effective as a source for initiating reaction in the adjacent mass, the hot spot must expld by self-heating. Opposing the tendency toward expln is cooling by heat flow from the hot spot to the surrounding cooler medium

Consider the hot spot (at time zero) to be a tiny sphere of material at a uniform temp greater than that of the surroundings. If the material were inert and produced no heat by reaction, the cooling of the sphere in subsequent periods of time would be represented by the temp distribution curves in Fig 7 (Ref 6). These are derived from the classical treatment of the differential equation for heat conduction and may be found in Carslaw and Jaeger (Ref 5). Time is depicted in terms of a dimensionless parameter $\alpha t/a^2$, where "a" is the radius of the sphere and α is its thermal diffusivity [$\alpha = \lambda/(\rho c)$]

Note that the central portion of the hot spot gets progressively cooler as $\alpha t/a^2$ increases as a result of increased t and α or decreased a. Thus, a very small hot spot in a medium of high thermal diffusivity will not stay "hot" for very long

Regardless of how the hot spot in an expl is created, its chemical reaction will occur at a much higher rate than that in the body of the expl, where it may be virtually zero. However, during most of the induction period before expln

the amount of heat produced by the chemical reaction is very small, and the cooling behavior is little affected by the fact that reaction is taking place. To state this differently: the temp rise at any point in the hot spot caused by chemical reaction during the induction period is small compared to the initial difference in temp between the hot spot and the rest of the expl; therefore, the temp gradient that develops in this region, and consequently the flow of heat during this time, is affected very little by the fact that the material is reactive and not inert. The temp profiles in Fig 7, therefore, are a close approximation to those that would be obtained in an expl hot spot during the period prior to expln

Since chemical rate decreases drastically even for small decreases in temp, the reaction of a hot spot can be quenched by a "cold front" reaching the center of the hot spot. Therefore, unless a thermal expln occurs at the center of the hot spot before the cooling wave reaches that point, there will be no expln in the hot spot at all. From the curves in Fig 7, it may be seen that the maximum time available for an expln to occur is, therefore, equal to about 0.04 dimensionless time units. Hence, according to Ref 7, the criterion for expln may be expressed as

$$t_e \leq 0.04 a^2/\alpha \quad (14)$$

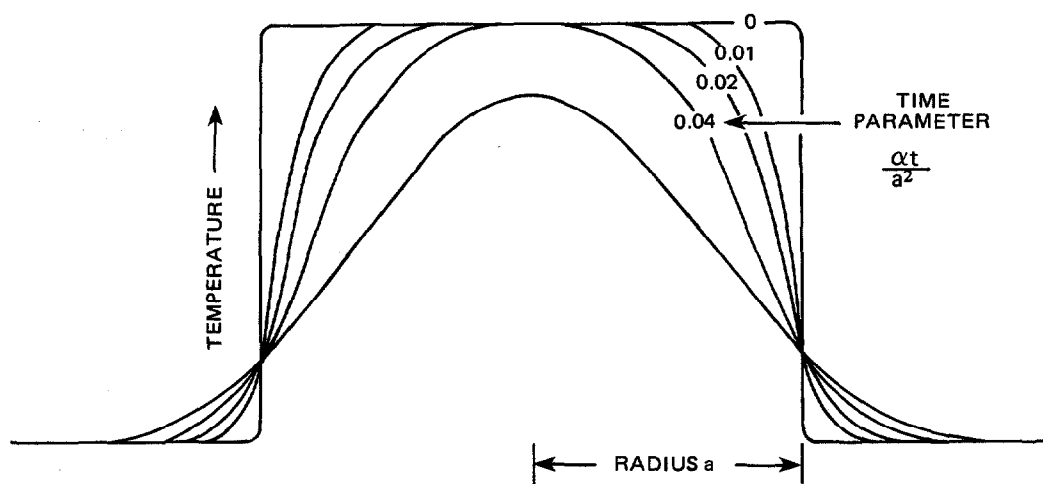

Fig 7 Temperature Distribution During Cooling of a Spherical Element of Inert Material That Has Been Raised Initially to a Uniform Temperature Greater Than That of the Surroundings.

Eq 14 combined with adiabatic expln times (Eq 12) can be used to estimate hot spot size as a function of hot spot temp. However, in the real world hot spot conditions are neither adiabatic nor is their chemical reaction zero-order. Consequently, several investigators have attempted to obtain solutions of Eq 4 under realistic hot spot conditions. Possibly the most successful of these attempts are those of Merzhanov & co-workers (Refs 11, 17 & 18). The more limited results of Friedman for semi-infinite slabs (Refs 9, 9a & 13) are also pertinent. The basic eqns of the Merzhanov treatment (Ref 11) are shown in Vol 7, H171-R to H172-L. Consequently, they will not be repeated here. Similarly, Friedman's analytical results (Ref 13) for an approximate solution are summarized in Vol 7, H172

A good approximate eqn for Friedman's numerical solution for a slab (Ref 9) is:

$$a_{cr}^2 = \left[\frac{\lambda(T_0 - T_1)}{\rho Z Q} \right] \exp \left[\frac{E}{RT_0} \right] \quad (15)$$

Calcs of the critical radius for *Tetryl*, based on the Merzhanov & Friedman treatments are compared in Table 2. Agreement is quite good. However, note that, as expected, critical radii based on the Frank-Kamenetskii-Chambré treatment (steady-state conditions) are considerably smaller than those computed via the hot spot approach. For comparison, Eq 14 (based on Ref 7) gives $a_{cr} = 2.76 \times 10^{-3}$ cm for a *Tetryl* sphere at 700°K, and $a_{cr} = 2.37$ cm at 445°K, in close agreement with Merzhanov

Approximate solutions of the heat eqns for hot spots have also been obtained by various authors other than those given in Refs 7, 11 or 13. These solutions will be described (briefly) below using the following dimensionless quantities:

Table 2
Critical Radius for Thermal Explosion of *Tetryl* *

Method	Geometry	Initial Temp ** (°K)	Critical Radius (cm)
Merzhanov (Ref 11)	slab	445	1.42 (a)
"	cylinder	445	1.90
"	sphere	445	2.18
"	slab	700	1.78×10^{-3} (a)
"	cylinder	700	2.36×10^{-3}
"	sphere	700	2.70×10^{-3}
Friedman (Ref 13)	slab	445	1.36 (a)
"	slab	700	1.62×10^{-3} (a)
Friedman (Ref 9)	slab	445	1.42 (a)
"	slab	700	2.19×10^{-3} (a)
Frank-Kamenetskii-Chambré (Refs 2 & 4)	slab	445	0.445 (a, b)
"	slab	700	5.17×10^{-4} (a, b)
"	cylinder	445	0.670 (b)
"	cylinder	700	7.79×10^{-4} (b)
"	sphere	445	0.863 (b)
"	sphere	700	1.00×10^{-3} (b)

* The following thermal and kinetic parameters were used:

$\rho_0 = 1.6$ g/cc; $\lambda = 6.8 \times 10^{-4}$ cgs units; $Q = 330$ cal/g; $E = 35000$ cal/mole; $Z = 10^{13}$ sec⁻¹ and $R = 1.987$ cal/deg mole

** Ambient temp = 300°K in all cases

(a) Half-thickness of slab

(b) Steady-state conditions

Variables:

$$\theta = \frac{E}{RT_0^2} (T - T_0); \quad \xi = \frac{x}{a};$$

$$\tau = t \frac{Q}{c_0} \frac{E}{RT_0^2} Z \exp(-E/RT_0)$$

Parameters:

$$\delta = \frac{Q}{\lambda} \frac{E}{RT_0^2} a^2 Z \exp(-E/RT_0);$$

$$\theta_0 = \frac{E}{RT_0^2} (T_0 - T_1); \quad \beta = \frac{RT_0}{E}$$

Friedman (Ref 9a), in an early study, assumed that reaction within a hot spot occurs at a constant rate regardless of temp (ie, for $\xi < 1$ $\exp \theta \equiv 1$); and outside the hot spot the reaction rate is zero. He obtained $\delta_n = b_n \theta_0$ and $b_n = b_0 = 1$ for a slab

Thomas (Ref 10), using the above approach, gives $b_1 = 2.6$ and $b_2 = 4.7$ for cylindrical and spherical hot spots respectively

Boddington (Ref 8) integrated the general heat eqn

$$\frac{\partial \theta}{\partial \tau} = \exp \theta + \frac{1}{\delta} \left(\frac{\partial^2 \theta}{\partial \xi^2} + \frac{n}{\xi} \frac{\partial \theta}{\partial \xi} \right)$$

$$\tau = 0 \begin{cases} \theta = 0 & \xi < 1 \\ \theta = -\theta_0 & \xi > 1 \end{cases} \theta_0 > 0 \dots$$

$$\tau \geq 0 \quad \xi = 0 \quad \frac{\partial \theta}{\partial \xi} = 0 \quad \xi = \infty \quad \frac{\partial \theta}{\partial \xi} = 0$$

over the hot spot volume by using the Gauss formula to convert the volume integral to a surface integral. He also used the simplifying assumptions that (a), the mean reaction rate

in the hot spot, is equal to the reaction rate at the average hot spot temp, ie $\overline{\exp \theta} \approx \exp \bar{\theta}$, and (b), heat flows at the surfaces of reacting and inert hot spots, are identical. His results are: $\delta_n = c_n \theta_0^2$ and $c_n = (n+1)^2/2\pi$. In this notation, n is equivalent to ℓ of Eq 6. Thus, $n = 0, 1$ & 2 for slabs, cylinders and spheres respectively

Although we have already discussed Zinn's method (Ref 7), his solution in dimensionless form was not given. It is $\delta_n = a_n$ with $a_2 = 25$ and $a_0 = 8$ for $\tau_a = 0.04\delta$. The a_0 was obtained by Friedman (Ref 9a)

The method used by Thomas (Ref 10) is essentially a combination of the methods of Zinn and Boddington. His initial conditions are $\tau = 0 \quad \bar{\theta} = -\ln(1 - \delta/a_n)$ which lead to:

$$\delta_n = \frac{a_n}{1 + (2a_n/c_n)^{1/2} \theta_0^{-1} + (a_n/c_n) \theta_0^{-2}}$$

As might be expected, at low values of θ_0 the Thomas formula changes to that of Boddington, and at high values it changes to that of Zinn

A summary and comparison of the several methods is given in the following tabulation taken from Ref 11:

All these methods give the general solution

$$\delta_n = f_n(\theta_0) \quad (16),$$

but it is obvious that the form of the function f_n varies greatly. Merzhanov (Ref 11) computed the difference in δ_n between his calcs and

Authors of methods		Zinn	Friedman	Boddington	Thomas	Barzykin, Gontkovskaya, Merzhanov
Reference		6 & 7	9 & 9a	8	10	11
General shape of function $f_n(\theta_n)$		a_n	$b_n \theta_0$	$c_n \theta_0^2$	$\frac{a_n}{1 + (2a_n/c_n)^{1/2} \theta_0^{-1} + (a_n/c_n) \theta_0^{-2}}$	$d_n (\ln \theta_0)^{m_n}$
Values of Constants	$n = 0$	$a_0 = 8$	$b_0 = 1.0$	$c_0 = 0.159$	—	$d_0 = 2.66$ $m_0 = 1.3$
	$n = 1$	—	$b_1 = 2.6$	$c_1 = 0.637$		$d_1 = 7.39$ $m_1 = 0.83$
	$n = 2$	$a_2 = 25$	$b_2 = 4.7$	$c_2 = 1.433$		$d_2 = 12.1$ $m_2 = 0.6$

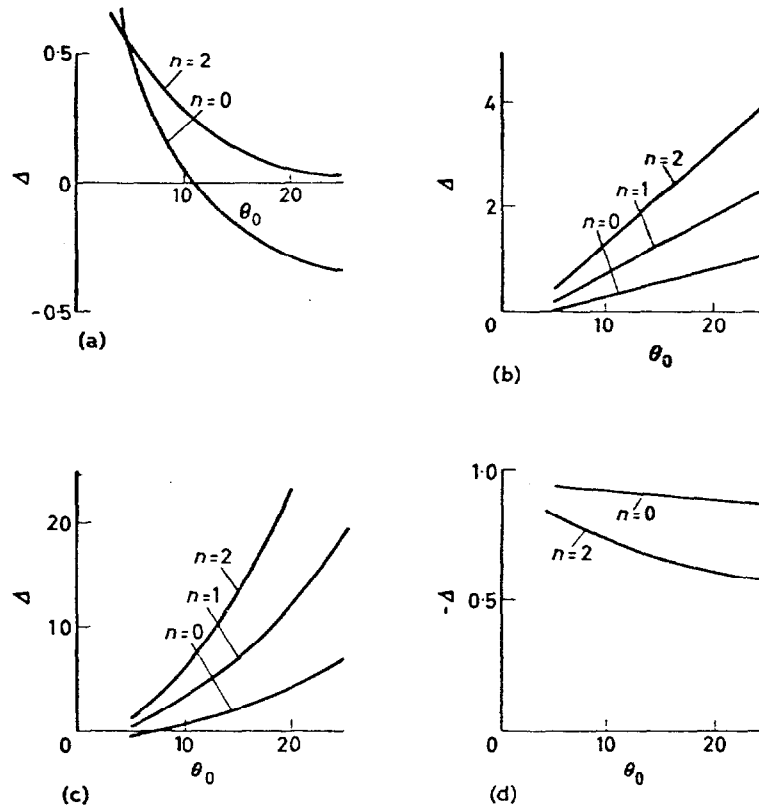

Fig 8 The Relative Error of Calculation of δ_n by Approximate Methods as a Function of θ_0 and n ; (a) Zinn Method; (b) Friedman Method; (c) Boddington Method; (d) Thomas Method

those of other authors. He calls this difference, Δ , "a relative error in the calculation of δ_n ." His "relative errors" are shown as a function of θ_0 in Fig 8

Disagreement between the Merzhanov method and those of Boddington or Friedman is quite pronounced, particularly for $n = 2$ (spheres). However note that, as shown in Table 2, agreement between subsequent Friedman calcs for slabs and those of Merzhanov is satisfactory. To rationalize the different forms of f_n in Eq 16 obtained by various authors, Merzhanov (Ref 11) states the following: "Generalizing the results of many numerical calculations of the curves $\theta(\xi, \tau)$ at δ close to δ_n and for different θ_0 and n it may be stated that:

- (a) the temperature on the hot spot surface θ_s fall rapidly (over a time a little shorter than the induction period) from 0 to the value $-(1-e)\theta_0$ and afterwards re-

mains much the same all through the induction period;

- (b) the temperature in the hot spot centre θ_c gradually increases and at the end of the induction period reaches the values which exceed the pre-explosion heating in non-hot spot problems on thermal explosion.

Thus the temperature difference between the centre and the surface of the hot spot is great throughout the whole induction period. With strong temperature gradients in the hot spot simplification of the exponential term may lead to wrong results."

In view of the above, one should expect that Boddington's approximation of $\exp \theta = \exp \bar{\theta}$ can result in serious errors. For a detailed analysis of these errors see Ref 11. Also included in Ref 11 are critiques of the Zinn, Friedman and Thomas methods. Merzhanov's qual description

of the thermal expln of a hot spot can be found in Vol 7, H171-L

3.0 Applications

Thermal expln theory has many practical and theoretical uses. Two practical applications and several theoretical applications of thermal expln phenomena will be considered below

An appropriate question to ask is whether thermal expln theory can be applied to designing safe storage of expls. A more direct question can be formulated as: how much expl can be safely stored at various ambient temps? An answer to these questions is provided by Eqns 9 and 12. This answer will err in the direction of safety by underestimating both the critical size and the storage life at a given ambient temp. As an example, Table 3 (from Ref 19) gives critical diameters and minimum storage lives for RDX spheres at various ambient temps. Of course the numerical results will depend strongly on the kinetic parameters used in the calcn, and to a lesser degree on the thermal parameters. The parameters used in constructing Table 3 are the same as those given for RDX in section 2.4 for Fig 4

Table 3
Critical Diameter and Adiabatic Explosion Time for RDX

Temp, °C	Critical Diameter*	Adiabatic Explosion Time**
50	540 meters	9200 years
75	148 meters	6.8 years
100	41 meters	27 weeks
125	5.8 meters	3.8 days
150	1 meter	3 hours
200	5.6 cm	30 seconds

* Surface of explosive sphere at constant temperature

** Sphere of explosive at uniform initial temperature

Note the long storage life and large critical diameters at low ambient temps and their drastic decrease as ambient temp is increased

Practical experience shows that in disposal of expls by burning, it is imperative to spread the expl into thin layers to avoid detonation. The rationale for this well-known fact is provided by Fig 4. According to Fig 4 and the discussion

in section 2.4, reaction takes place primarily at the surface of the charge when $T_s \gg T_{cr}$, as it usually is for expls in a fire. In a thin layer of expl such a surface reaction can consume most of the expl prior to the build-up of a violent reaction because most of the expl reacts essentially unconfined. Analogous reasoning implies that a hot fire is desirable ($T_s \gg T_{cr}$), otherwise reaction may occur largely in the interior of the expl ($T_s \approx T_{cr}$), and this reaction will be confined by the outer layers of expl and is likely to turn violent

The obvious importance of the thermal expln of hot spots in the theoretical description of the initiation of detonation by impact or shock was presented in Vol 7, H170-175, I43-55, L31-32, and in this Vol under "Shock Initiation", a section under "Shock Sensitivity of Explosives". Consequently no further discussion of these phenomena will be given here

The writer studied the initiation of Pb Azide by high-intensity light (Ref 9b). He found that the process of initiation was thermal, with thermal expln occurring in a thin layer that was heated by absorbing most of the incident light. He was able to make estimates of the kinetic parameters of Pb Azide based on observed initiation delays and thermal expln theory

Merzhanov & Stolin (Ref 17) examined hydrodynamic heating of a viscous fluid undergoing Couette-type flow. After developing the general equations, they obtained physical analogies between Couette flow and the well-known hydrodynamic heating that occurs in a Newtonian fluid with an exponential dependence of viscosity on temp. They present conditions under which hydrodynamic heating becomes non-stationary and leads to high temps and the likelihood of thermal expln

3.1 Thermal Explosion as a Method of Studying Chemical Kinetics

The methods of classical kinetics are not applicable to the study of rapid exothermic reactions. On the other hand, expln measurements of thermal explns (which are relatively simple to obtain) can yield kinetic data for the reactions taking place during the pre-expln induction period, provided that these observations are interpreted correctly, ie, using a sound theoretical basis. Thus, extraction of kinetic data from thermal expln measurements is likely

to be more of a theoretical than a practical problem

This subject has been examined in detail by Merzhanov and co-workers (Refs 14, 15, 16 & 18) and to a lesser extent by Rogers (Ref 20)

In Ref 14, Merzhanov summarizes the theoretical development and gives equations that relate observable quantities to kinetic parameters for different exptl approaches. These exptl methods are:

- Determination of critical conditions for thermal expln
- Determination of max temp for no expln
- Determination of induction times

In the last method he examines induction times obtained under adiabatic conditions, times obtained in a process without thermal gradients, and induction times for ignition

The exptl measurements used by Merzhanov and co-workers were (in his terminology):

- The *thermographic* method which obtains critical conditions for thermal expln of reactants heated in a manner to keep temp gradients at a minimum

- *Thermal explosion of particles* in which small spheres of reactant are quickly introduced into a heated gas stream, and induction times and critical temps are determined by observing

Table 4

Kinetic Parameters of Cellulose Nitrate Thermal Decomposition

Method	Source temperature, °C	Equation No	Figure No	QZ $\frac{\text{cal}}{\text{g sec}}$	E $\frac{\text{kcal}}{\text{mole}}$
Thermal explosion of particles	223–255	5	Figure 1 curve 3	$10^{21.63}$	48.5
	320–420	10–13	Figure 4 curve 1	$10^{23.00}$	50
Contact ignition by a block	212–242	14	Figure 3 curve 4	$10^{22.38}$	47.7
Ignition by a flow of gas	300–350	18	Figure 3 curve 1	—	48
Experiments under isothermal conditions	140–165	—	—	$10^{21.87}$	47

Kinetic Parameters of Polyvinyl Nitrate Thermal Decomposition

Method	Source temperature, °C	Equation No	Figure No	QZ $\frac{\text{cal}}{\text{g sec}}$	E $\frac{\text{kcal}}{\text{mole}}$
Thermal explosion of particles	224–254	5	Figure 1 curve 4	$10^{16.71}$	37
	247–450	10–13	Figure 4 curve 3	$10^{15.86}$	35
Ignition by a flow of gas	260–310	18	Figure 3 curve 3	—	38
	270–310	17	—	—	38.1

glow of the expln products

- *Contact ignition by a block* in which smooth-faced samples are rapidly brought into contact with a massive hot Al block and induction times are determined at different block temps

- *Ignition by a flow of gas* (sic) in which sample cylinders of various diameters are introduced into a hot gas stream with the cylinder axis normal to the gas flow. Induction times are measured for varying gas compns and temps

Results obtained in Refs 14 & 15 are summarized in Table 4. Here the columns labelled "Equation No" and "Figure No" refer to Merzhanov's article (Ref 14)

Additionally, the "thermal expln of particles" method was used in the range of 277–500° to obtain $E = 38\text{kcal/mole}$ and $ZQ = 10^{19}\text{ cal/g sec}$ for *Nitrostarch*. However, under isothermal conditions (95–117°) the initial step rate constant for *Nitrostarch* was found to be $k = 10^{14.9} \exp(-36000/RT)\text{sec}^{-1}$

This method was also used with Ba Azide (Ref 15), in the temp range of 260–370° to obtain $E = 35\text{kcal/mole}$ and $QZ = 10^{15.17}\text{ cal/g sec}$

The thermographic method was used to determine kinetic parameters for *DINA* (Dinitroxydiethylnitramine) and *Tetryl*. For *DINA* (over 147–62°) $E = 45\text{kcal/mole}$ and $QZ = 10^{21.29}\text{ cal/g sec}$, as compared to $E = 45\text{ kcal/mole}$ and $Z = 10^{18.58}\text{sec}^{-1}$ obtained under isothermal conditions. For *Tetryl* (over 132–53°), $E = 38\text{kcal/mole}$ and $QZ = 10^{17.8}\text{ cal/g sec}$, as compared to $E = 38\text{kcal/mole}$ and $Z = 10^{15.62}\text{sec}^{-1}$ obtained under isothermal conditions

In general, with the exception of *Nitrostarch*, agreement is satisfactory between kinetic parameters obtained from thermal expln studies and isothermal measurements. However, Z values obtained by either approach for Nitrocellulose or *DINA* appear to be considerably higher than expected on the basis of classical kinetics

In a more recent study (Ref 16), Merzhanov's school used high dilution with inert materials to study the kinetics of exothermic reactions over a wider temp range than was previously feasible. Dilution prevents self-ignition of the studied sample and also minimizes temp gradients. The method used is an adaptation of DTA (differential thermal analysis) in which temp

measurements are made differentially between equal masses of the diluted reactant and the neat diluting medium. Kinetic parameters obtained for Nitrocellulose diluted with Al oxide are in good agreement with those given in Table 4. These expts also showed that the decompn of Nitrocellulose is a two-stage process

3.2 "Quenching" of Thermal Explosion

In a series of studies, summarized in Ref 18, Merzhanov and co-workers examined conditions under which thermal explns may be quenched. This theoretical analysis provided two characteristic dimensionless parameters which determine the conditions for quenching. These are κ_{cr} obtained from inflection points of θ_M vs κ plots (θ_M is the max value of θ), and a quantity $\epsilon = [(\theta_M/\kappa)(d\theta_M/d\kappa)]_{\kappa=\kappa_{cr}}$, which is a measure of the uncertainty in the determination of the critical conditions. Both κ_{cr} and ϵ are functions of β and γ , which (as well as κ and θ) are defined as follows:

$$\theta = \frac{E}{RT_0^2} (T - T_0),$$

$$\kappa = \frac{Q}{\alpha \frac{S}{V}} \cdot \frac{E}{RT_0^2} Z \exp\left(-\frac{E}{RT_0}\right),$$

$$\beta = \frac{RT_0}{E},$$

$$\gamma = \frac{c}{Q} \frac{RT_0^2}{E}$$

Here T = temp of reacting material, T_0 = temp of the surrounding medium, S = surface of the heat-generating material, and V is its volume; α = heat transfer coefficient

Machine computation was used to obtain κ_{cr} and ϵ as functions of γ and β . The "thermographic" test procedure was then employed to obtain κ and ϵ , from observed ΔT_{max} vs T_0 plots, for mixts of *Tetryl* and *Picric Acid* (claimed to be a first-order decompn reaction), and for a *Tetryl/chalk* mixt (claimed to be an autocatalytic decompn). Agreement between calcd and observed κ 's and ϵ 's was excellent

All these studies are somewhat pedantic, in that they provide rigorous proof for a well-established fact, namely that quenching the thermal expln of expl materials is well-nigh impossible if β is sufficiently large. Merzhanov and co-workers also show that many exothermic

reactions (of non-expl materials) occur under conditions that are still outside the regions of criticality for quenching

Written by J. ROTH

Refs: 1) D.A. Frank-Kamenetskii, *ActaPhysChem USSR* **10**, 365 (1939) 2) P.L. Chambré, *JChemPhys* **20**, 1705 (1952) 3) H. Eyring et al, *ChemRevs* **45**, 69 (1949) 4) D.A. Frank-Kamenetskii, "Diffusion and Heat Exchange in Chemical Kinetics", Princeton Univ Press (1955) 5) H.S. Carslaw & J.C. Jaeger, "Conduction of Heat in Solids", Oxford Press (1959) 6) J. Zinn & C.L. Mader, *JApplPhys* **31**, 323 (1960) 7) J. Zinn, *JChemPhys* **36**, 1949 (1963) 8) T. Boddington, 9th SympCombust, 287 (1963) 9) M.H. Friedman, *Ibid*, 294 9a) *Ibid*, *TransFaradSoc* **59**, 1865 (1963) 9b) J. Roth, *JChemPhys* **41**, 1929 (1964) 10) P.H. Thomas, *Combust & Flame* **9**, 369 (1966) 11) A.G. Merzhanov, *Ibid* **10**, 341 (1966) 12) J. Roth, Final Rpt SRI Proj GHU 5476, Contr NOwr 65-0283-d, Stanford Res Inst (1966) 13) M.H. Friedman, *Combust & Flame* **11**, 239 (1967) 14) A.G. Merzhanov, *Ibid* **11**, 201 (1967) 15) Yu.M. Grigoriev et al, *FizGorVzryva* **3**, 512 (1967) 16) E.P. Goncharov, A.G. Merzhanov et al, *DAN* **197**, 385 (1971) 17) A.G. Merzhanov & A.M. Stolin, *DAN* **198**, 1291 (1971) 18) A.G. Merzhanov et al, *ZhFizKhim* **45**, 379 (1971) & *CA* **74**, 128338 (1971) 19) Anon, *Engrg Des Hndbk*, "Principles of Explosive Behavior", **AMCP 706-180**, Chapter 10 (1972) 20) R.N. Rogers, *ThermochimicaActa* **187**, 1 (1972); also see "Kinetics" in Vol 7, K11-L to K13-L

Thermal Ignition. See under "Ignition" in Vol 7, I11-L to I30-R

Thermal Initiation. See under "Initiation" in Vol 7, I106-L to I109-L

Thermate and Thermite. *Thermite*, one of the most common pyrot incendiary agents, is essentially a mixt of powdered ferric oxide and powdered or granular Al. When raised to its combination temp an intense reaction occurs whereby the oxygen in the ferric oxide is transferred to the Al, producing molten Fe, Al oxide, and releasing 795 kilocalories per gram molecule ($8\text{Al} + 3\text{Fe}_3\text{O}_4 \rightarrow 4\text{Al}_2\text{O}_3 + 9\text{Fe}$). This exothermic reaction may produce a temp of about 2500° under favorable conditions. The white-hot molten Fe and slag may itself prolong and extend the heating and incendiary action

Thermite was used for industrial purposes, such as welding railway lines, prior to WWI. It was used quite extensively as a military incendiary agent during WWI by most of the major combatants. Commercial Thermite is simply a loose mixt, but for military purposes a binder was necessary to prevent separation of the constituents. Na or K silicate or S were usually used for this purpose. Where a concd incendiary effect was required, the silicate binder was more effective, since the molten products were able to penetrate metal and prolong the incendiary action. Where a scattering action was required, S was used, as in the Fr *Daisite*, since this compn burns with expl violence and spatters small drops over a large area. Celluloid was also used as a binder, chiefly by Ger. Other substances including resins, paraffin and pitch, have also been tried as binders

Other pyrot mixts have been used as igniters for Thermite. Where a scattering effect was desired a rapid igniter was used, such as the Brit *Ophorite*, consisting of 9p Mg powder and 13p K perchlorate. This was used extensively by US and Brit forces during WWI in incendiary shells and also in certain types of gas shells

A number of modifications of Thermite were tried during and after WWI. Cu, Ni, Mn and Pb oxides were tried in place of Fe oxide, but had no greater effect. The Ger used a mixt of Mn oxide and Mg in certain early incendiary bombs. Later in the war the Brit introduced "flaming

Thermite" composed of powdered Al/Ba nitrate/ferrous oxide 3/6/8p

Thermate is the general name given to a number of mixts of Thermite and pyrot additives, several of which were developed before and during WWII. One use was as a component in igniter compns for Mg incendiary bombs. Three of these formulations were termed *Therm-8*, *Thermate-TH2*, and *Thermate-TH3*. *Therm-8* was the precursor of later, improved igniting formulations. TH2 differed from *Therm-8* in that it contained no S and slightly less Thermite. TH3 was found to be superior to the others and was adopted for use in an incendiary Mg bomb. Its compn by wt is Thermite 68.7, Ba nitrate 29.0, S 2.0 and oil (binder) 0.3%. In the bomb, a TH3 core is ignited by a primer charge, the burning core then melts and ignites the Mg alloy body of the bomb. The incendiary action on the target is localized since there is little scattering of the incendiary material

Thermite does not have the same ability as Mg or oil incendiary agents to start secondary fires because its heat of combustion is comparatively low and because it burns so quickly. However, the high temp produced by burning Thermite is sufficient to melt iron or steel with which it comes in contact, and it is very effective as an igniter for Mg bombs. It is still used in hand grenades and bombs

See also in Vol 7 under "Incendiary Warfare", I70-R, I72-R, I73-L & R, I75-R and I77-R, and in Vol 8 under "Pyrotechnics", P512-L
 Refs: 1) A.M. Prentiss, "Chemicals in War", McGraw-Hill, NY (1937) 2) J.B. Fischer, "Incendiary Warfare", McGraw-Hill, NY (1946) 3) L.W. Greene, "Prewar Incendiary Bomb Development", Chemical Corps Journ (Oct 1947), 25-30 4) S.J. Buginas, "Thermit Welding: A Selective Bibliography", Rept SB 6325, Lockheed Missiles & Space Co, Sunnyvale (1963), (AD 439446) 5) A. Stettbacher, "Development of Heat and Light from Burning and Lighting Compositions", PATM 1593 (1965), (AD 467507L) [Engl translation of Nitrocellulose 13, No 11, pp 203-07 & 13, No 12, pp 224-29 (1942)] 6) Anon, EngrgDesHndbk, "Military Pyrotechnics Series, Part One, Theory and Application", AMCP 706-185 (1967), 5-22 to 5-25 7) Ellern (1968), 220, 221 ff & 244 ff 8) Kirk & Othmer, "Encyclopedia of Chemical Technology", 3rd Ed, Vol 5 (1979), 404

THEMOCHEMISTRY

Introduction

Thermochemistry is an extension of the more general science of thermodynamics (see following article) which treats the relation between energy effects of all kinds attending changes in physical systems. Whereas, its name notwithstanding, thermodynamics deals with the description of static, ie, equilibrium states, thermochemistry covers all thermally induced changes, their kinetics and their mechanisms (the 'paths'). Thermochemistry is concerned, therefore, with the direction of the changes and the magnitudes of the effects. Whereas thermodynamic data are empirical, thermochemical data suppose knowledge of the rate laws and time becomes an important variable. Thermochemistry is therefore important in any discussion of expls and like energetic chemical systems

Thruout this article previous coverage in the Encyclopedia has been referenced. The contents have been organized into the following sections:

1. Units
2. Heats of Reaction
3. Reaction Temperature
4. Use of Thermodynamic Tables
5. Experimental Thermochemistry
6. Instrumental Tools
7. Hazard Assessment
8. Sources of Thermochemical Data
9. References

1.0 Units

Metric units, as opposed to the "Système Internationale" (SI) units, have been employed thruout this Encycl. For this reason, metric units have been retained in this article. Conversion factors from quantities encountered in Thermochemistry to SI units are listed below:

Heat Capacity:

cal/gmole °K	4.1868 (kJ/kgmole °K)
BTU/lb mole R	4.1868 (kJ/kgmole °K)

Enthalpy, Free Energy:

kcal/gmole	4.1868 (MJ/kgmole)
kcal/cm ³	4.1868 x 10 ³ (MJ/m ³)
BTU/lb mole	0.4806 (kJ/kgmole)

Entropy:

cal/gmole °K	4.1868 (kJ/kgmole °K)
BTU/lb mole R	4.1868 (kJ/kgmole °K)

Density:

g/cm ³	1 x 10 ³ (kg/m ³)
lb/in ³	2.768 x 10 ⁴ (kg/m ³)

Universal Gas Constant:

1.9864 (cal/gmole °K)	8.3136 (kJ/kgmole °K)
-----------------------	-----------------------

Pressure:

Atmosphere	1.01325x10 ⁵ Pa (lbf/in ²)	6.8947x10 ³ Pa
Bar	1x10 ⁵ Pa	(N/m ²) 1.000Pa
Mm of Hg	1.333x10 ² Pa	(kgf/m ²) 9.8066Pa

2.0 Heats Of Reaction

The sources and magnitudes of thermochemical data have been the subject of many entries in this Encycl. The use of the data presupposes a general acquaintance with chemical thermodynamics (next article) and with detonation theory (Vol 4, D268-L to D298-R). The principle difference between classic thermodynamics and the thermochemistry of reactive systems is that explns and deflagrations do not represent equilibrium processes. In principle, the heat of reaction is obtained by:

$$\Delta H_R = \sum \Delta H_f(\text{prod}) - \sum \Delta H_f(\text{react}) \quad (2.1)$$

The heats of formation from the elements, ΔH_f^{298} , in the reference state, are thermodynamic quantities which are tabulated (see Sect 8 of this article). In this discussion the convention of a negative heat of reaction for an exothermic reaction has been used

When analyzing the energetics of a reaction one must remember that chemical equilibria depend on the total pressure of the system and that, therefore, the heat of reaction of an expln or of a proplnt changes as the products expand and the total pressure decreases. This problem is particularly acute in detonations for which the compn of the shocked state is unknown and for which the calorimetrically measured heat is in fact for the "frozen" or the expanded compn. Moreover, often the tabulated heats of detonation are "corrected" for the heat of vaporization of the water which is one of the principle reaction products. Whereas tabulated data constitute the base from which the theoretical properties of expls can be calcd, there is no connection between the heat of expln, the heat of formation and the "sensitivity" of an expl. For instance, aliphatic

nitrate esters (certainly sensitive compds), as shown in Table 1, have a negative heat of formation, whereas secondary nitramines (which for reaction kinetic reasons are more "stable" than nitrate esters), have a positive heat of formation. An excellent comparison between the heats of expln for confined and unconfined events is that of Ornellas (Ref 21) who drew the following generalizations:

1) Confinement increases the heat of expln in oxygen deficient expls but not in oxygen balanced expls

2) In oxygen deficient expls an appreciable fraction of the carbon product is in elemental form even though sufficient oxygen is present for gasification. This is a consequence of Le Chatelier's Principle that with increasing pressure the number of molecules of gaseous products tends to be minimized by a shift to condensed reaction products

Calcns have shown that if an expl is oxygen balanced, the water gas equilibrium determines the compn of the products:

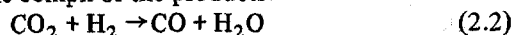

which is insensitive to changes in pressure. Therefore, aliphatic nitrate esters, for instance, have the same product compn at detonation and at ambient pressure. On the other hand, the reaction products of oxygen deficient expls show a marked dependence on the degree of confinement and likewise, the measured heats of reaction will depend on whether they were detd at ambient pressures or under shock conditions.

Exptl data for the heats and products of detonation of confined and unconfined expls are given on p 3.10 of Ref 34

A useful application of the heat of expln is to predict the ability of an expl to produce and accelerate fragments. This is accomplished by the so-called Gurney formulas (Vol 6, G195-R). Other applications involve the prediction of air-blast and underwater performance of expls as described on pp 3.16-3.19 of Ref 34

A very important application of the heats of reaction is the calcn of the reaction temp of proplnts which determine in part the ballistic performance. Heats of reaction also permit the calcn of the adiabatic reaction temp of pyrot reactions which are of value in judging the luminous yield of flares as well as the heat output of thermite reactions

3.0 Calculation Of The Adiabatic Reaction Temperature

As long as one has to consider no more than a single chemical reaction, one need compute only a single equilibrium constant from which the equilibrium compns are readily obtained. When, however, chemical processes take place at extreme temps and pressures, a large number of simultaneous equilibria may exist. For example, to calculate the flame temp for the combustion of a hydrocarbon in air it may be necessary to consider as many as 20 chemical reactions. As the number of reactions increases, so does the mathematical difficulty because no

Table 1
Thermal Properties of Selected Explosives

	ΔH_f^{298} kcal gmole	ΔH_{det} kcal gmole	Oxygen Balance (*)
<i>Aliphatic Nitrate Esters</i>			
Nitroglycerine	-90.8	-333.7	3.5
PETN	-126.7	-474.0	-10.0
<i>Nitramines</i>			
HMX	17.9	-438.1	-22.0
RDX	14.7	-306.4	-22.0
<i>Aromatic Nitro Compounds</i>			
TNT	-17.8	-347.3	-77.0

(*) Assuming that all hydrogen is oxidized to water and all carbon to dioxide

longer can the simultaneous equilibrium constants be solved in closed form and it becomes necessary to use either a trial and error or an iterative solution of the system of simultaneous equations

Not long ago a number of calculational methods were routinely used for the "manual" solution of special problems such as the calcn of compn of rocket exhaust gases (Refs 10 & 14). Other methods were intended to be multipurpose schemes which could, at least in principle, be applied to any chemical equilibrium problem. Prior to the advent of computers the special purpose schemes were common, but at present the predominant proportion of the computations of chemical equilibria are done with computers using multipurpose schemes. These are naturally complex and the reader is referred to the specialized literature (Ref 24)

We shall give an illustration of the calcn of the parameters for such a "machine" calcn and apply these to the calcn of the combustion temp of a proplnt. We shall also illustrate the "manual" calcn of the flame temp of a flare. Other applications of equilibrium calcns to pyrot problems have been published (Refs 40 & 45)

3.1 Reaction Temperature of a Propellant

Consider a solid proplnt containing 80% by weight ammonium perchlorate (AP) and 20% of a binder having the compn $C_{23}H_{28}O_4$. Based on 1 gram-mole of oxidizer, the elemental compn of the proplnt is therefore:

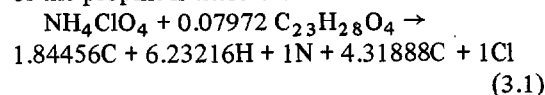

The heat of formation of AP is -69.42 kcal/gmole and that of the binder is approx -30 kcal/mole. Therefore, the heat of formation of the propellant is:

$$\Delta H_{f(\text{oxid})}^{298} + \Delta H_{f(\text{binder})}^{298} \rightarrow -69.42 + (-) 0.07972 \times 30 = -71.8116 \text{ kcal/g mole} \quad (3.2)$$

These data are used in a minimum free energy calcn (Refs 19, 30 & 56) which results in a listing of the combustion products and of a combustion temp for any value of chamber pressure. The computer program draws on data files for the heat capacities and heats of phase changes for the products as they have been made available in the JANAF data tapes (Ref 31)

3.2 Flame Temperature of a Magnesium-Sodium Nitrate Flare

Compns containing Mg and Na nitrate are used in many illuminating flares. There are several possible ways for this reaction to proceed which in turn determine the relative amounts of Mg and Na nitrate required for the stoichiometric chemical equation. Two examples are:



and



From the JANAF Tables (Ref 31) we find that Na oxide is thermodynamically unstable with respect to the elements above $2200^\circ K$ (ie, ΔF_f° becomes positive). Therefore, we conclude that Reaction (3.3) is less likely to occur than Reaction (3.4). From Equation (2.1) we calculate

$$\Delta H_R = 6(-) 143.8 + 2 \times 0 + 1 \times 0 - 6 \times 0 + 2 \times (-) 115.0 = 632.8 \text{ kcal}$$

The above data may be used in a computer solution as was done in Sec 3.1 or else the computation can be performed "manually" as will be illustrated here. The adiabatic reaction temp is detd by a trial and error procedure, equating the enthalpies of the reaction products to the heat of reaction:

$$\sum_{298}^T (H - H_{298}) + \Delta H_m + \Delta H_b = 632.8$$

The problem is to determine the temp at which the equality is satisfied.

The JANAF Tables report that Mg oxide vaporizes at high temps, and that the vapor pressure is appreciable at its melting point ($3100^\circ K$). Therefore, as a first approximation we shall assume that the flame temp is the melting point of the oxide. The enthalpies of the products, obtained from the JANAF Tables (Ref 31) are as follows:

Nitrogen ($H_{3100} - H_{298}$)	23.051 kcal/mole
Solid MgO (ΔH_f^{3100})	35.847 kcal/mole
For Gaseous Sodium	
H_m	0.622
H_b	23.285
liquid($H_{1100} - H_{298}$)	5.705
vapor($H_{3100} - H_{1100}$)	9.993
	<hr/>
	39.605 kcal/mole

The total enthalpy of the products at $3100^\circ K$, as computed from Equation (3.4) is

$$6 \times 35.847 + 2 \times 39.605 + 23.051 = 317.383 \text{ kcal}$$

Because this enthalpy is less than the computed heat

of reaction 632.8kcal, one can assume that the Mg oxide is molten. Mg oxide has a heat of fusion of 18.592kcal/mole. The revised enthalpy is:

$$6 \times 18.592 + 317.383 = 428.935\text{kcal}$$

The excess enthalpy (632.8-428.935=203.9kcal) goes into the vaporization of the oxide. The heat of vaporization of the oxide (*) is 133.807kcal/mole. Therefore, the heat of reaction is insufficient to raise the temp of the products above the melting point of the oxide and the first assumption was correct

4.0 Use Of Thermodynamic Tables

The two thermodynamic functions of greatest utility in thermochemical calcns are the enthalpy (H) which is for isobaric processes, equal to the heat generated or transferred by a chemical reaction, and the free energy (F) which permits the calcn of an equilibrium compn and the prediction of the direction of the reaction. Only when no products are vaporized by the reaction (as is the case in some pyrot reactions but never in explns or proplnt reactions) is the enthalpy change approx equal to the free energy change so that a negative heat of reaction is an adequate indication of the likelihood of the reaction. As a matter of convention, enthalpies and free energies are referred to a standard state, usually the solid at 298°K. Also by convention, enthalpies and free energies of formation of the elements are zero. The thermodynamic functions as function of temp are tabulated (see Sect 8) or they may be calcd from heat capacities. While the equilibria of complex reactions and of multi-component systems are today most profitably obtained by computer, the ability to use tabulated data is a great help in predicting the direction and the extent of a reaction. Although equilibria do not depend on the path of the reaction, in analyzing reactive systems one usually wishes to examine the equilibrium at the conditions of the reaction and not necessarily that of the standard state. For the calcn of the equilibria at high temps one must endeavor to determine which products are stable as otherwise profoundly erroneous results can be obtained, as was shown in the example of the flare flame temp in Sect 3.2

(*) the difference between the heat of formation from the elements of gaseous oxide at 3100°K and of liq oxide at 3100°K as found in the JANAF Tables (Ref 31)

The use of thermochemical data to estimate the heat effects in explns was discussed in Vol 7, H38-L to H46-R, where are listed also the heats of formation and detonation of common explns. A method of calculating the permissibility of explns was illustrated in Vol 3, C447-L to C450-L

The performance of proplnts is a unique function of the temp of the hot reaction products, their compn and their pressure. The proplnt burns at constant pressure and forms a set of products which are in thermal and chemical equilibrium with each other. The multiplicity of the reaction products requires that the combustion chamber conditions be calcd from the solution of simultaneous equations of pressure and energy balances. This calcn is best performed by computer, although the manual scheme has been described well by Sutton (Ref 14) and Barrère et al (Ref 10). The chamber conditions determine the condition in the nozzle which in turn characterizes the rocket engine performance in terms of specific impulse and characteristic exhaust velocity

The use of tabulated functions for the prediction of a thermochemical reaction as found in pyrot systems will be illustrated here. For example, if it were desired to prepare metallic Cr by carbon reduction of the Cr₂O₃, one must determine the conditions required to make the reaction proceed. For this calcn we are relying on the data in the JANAF Tables (Ref 31), these being most complete in the high temp region, although older compilations may be used as well (Refs 12 & 18)

From the principles of chemical thermodynamics (see next article) we know that the free energy change of the reaction:

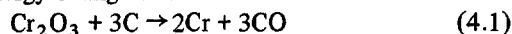

is given by:

$$\Delta F_T = \Delta H_T - T\Delta S \quad (4.2)$$

or

$$\Delta F_T = \Delta H_f^{298} - T(\Delta F_T - \Delta H_f^{298} / T) \quad (4.3)$$

Note that in Equation 4.1 one product is gaseous and that, therefore, Equations 4.2 or 4.3 will be required rather than Equation 2.1. The thermodynamic data for the products and the reactants are as follows:

	$\Delta H_f^{298} \frac{\text{kcal}}{\text{mol}}$	$S_f^{298} \frac{\text{cal}}{\text{mole}^\circ\text{K}}$	$(\frac{F_T - H_f^{298}}{T}) \frac{\text{cal}}{\text{mole}^\circ\text{K}}$
<i>Reactants</i>			
Cr ₂ O ₃	-271.2	19.396	19.396
3C(s)	0	3 x 1.359	3 x 1.359
<i>Products</i>			
2Cr	0	2 x 5.645	2 x 5.645
3CO(g)	3 x (-) 26.417	3 x 47.214	3 x 47.214
$\sum \text{Prod} - \sum \text{React}$	+191.95	+129.459	+129.459

At equilibrium, $\Delta F=0$. Substituting these values into Equation 4.2, we obtain

$$T = \frac{191950}{129.459} = 1483^\circ\text{K}$$

We conclude from the positive heat of reaction of 191.95kcal/mole that the reaction would not proceed spontaneously unless the temp were maintained above 1483°K. One can write a number of reactions for the reduction of Cr₂O₃ by carbon, such as the following:

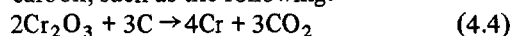

but we find, by performing the above calcn with CO₂ as a product, that a temp of 2660°K will be required. This shows again that unless care is taken in the selection of the most likely reaction products, erroneous conclusions can be reached

It would be interesting to determine whether the reaction could be made to proceed at reduced pressure if, for instance, the reagents could be held at 1300°K. From thermodynamic principles we know that:

$$\Delta F = RT \ln(P_2/P_1) \quad (4.5)$$

Calculating ΔF from the above enthalpy and entropy data and Eq 4.2 at 1300°K, we find that:

$$\Delta F = 191,950 - 1300 \times 129.459 = 23,654 \text{ cal/mole}$$

Setting $P_1=1$ atm, we find from Eq 4.5 that $P_2=1 \times 10^{-4}$ atm, a pressure readily attainable in a laboratory vacuum furnace

5.0 Experimental Thermochemistry

5.1 Heats of Reaction

5.1.1 By Bomb Calorimetry

The use of bomb calorimetry for the determination of heats of reaction and other calorimetric

determinations was briefly reviewed earlier (Vol 2, C10-L to C12-R). A much more detailed and current exposition is that of Sunner and Månsson (Ref 57). Bomb calorimetry remains the preferred exptl tool for the study of reactive systems. We have had occasion in Sect 1 of this article to describe some problems associated with the interpretation of the data

5.1.2 By Differential Scanning Calorimetry (DSC)

In the next section we shall examine the use of DSC for the determination of heats of reaction in greater detail. The method has the virtue of speed and economy and it consists of the integration of the area under a DSC exotherm. Special precautions must be taken to account for phase changes such as fusion and sublimation which may take place during the reaction (Ref 25); moreover, in cases of complex or consecutive reactions such as those found in pyrolys, bomb calorimetry is preferred. A recent review of exptl techniques for the study of the thermochemistry of expls was published by Collins and Haws (Ref 54)

5.1.3 By Manometric and Titrametric Methods

If one can determine equilibrium compns by suitable techniques as function of temp, one can compute both the heats of reaction and the entropies of reaction from:

$$\ln k = \exp - \frac{\Delta F}{RT} = \exp - \left(\frac{H_R}{RT} + \frac{S_R}{RT} \right) \quad (5.1)$$

This method was used by Freeman (Ref 8) to determine the heats of reaction of the nitrite-nitrate oxidation

5.2 Heat Capacities

5.2.1 By Calorimetry

This method was reviewed by K.K. Kelley

(Refs 2 & 4). The method consists of dropping the substance into a calorimeter operating at or near room temp. Changes in enthalpy of the substance between the temp of the furnace and that of the calorimeter are measured. Once the enthalpies, after repeated tests, are known as function of temp, heat capacities are obtained by differentiation:

$$C_p = (dH/dT)_p \quad (5.2)$$

This method tends to mask heats of phase transitions, and in the case of expls and similarly reactive materials, is severely limited in the range of temps

5.2.2 From Spectroscopic Data

"High temperature heat contents and specific heats of the simpler gases may be calculated statistically from spectroscopic data, that is, actual energy-level data for the gas molecules. When this method is applicable, it yields data with an accuracy which is beyond any direct experimental method. This method has been discussed by Giauque (1). Properties of gases for which complete energy level data are not available often may be calculated from knowledge of the molecular configuration and the fundamental interatomic vibration frequencies" (Refs 2 & 4)

5.2.3 By Differential Scanning Calorimetry

The earlier differential thermal analysis techniques (Vol 5, D1255-R to D1256-R) have been completely superseded by the newer technique of differential scanning calorimetry (DSC). We shall have occasion to discuss the operation of a DSC in the next section of this article. The great advantage of DSC in the determination of the heat capacity of temp sensitive materials derives from the fact that the heat capacity is directly proportional to the output signal (the pen displacement) which is calibrated by the manufacturer (*) making unnecessary the use of a reference substances. This technique has the accuracy of no better than 5%

5.3 The Study of Kinetics

5.3.1 Using Manometric and Titrametric Methods

By determining the reaction rate constant at several temps Freeman (Ref 8) was also able to obtain the heats of activation of the nitrate decomn and of the oxidation of the nitrite by

oxygen as well as the frequency factors from:

$$\ln k = \ln A - (E_a/RT) \quad (5.3)$$

Similarly, pyrolysis kinetics was studied manometrically by Hauser and Lee (Ref 20). If the components of the reaction are in solution, titrametric methods have been used (Ref 5). A good illustration is provided by H.P. Marshall et al in their study of the thermal decomn of hexanitroethane and of other polynitroalkanes in various solvents (Ref 26)

5.3.2 Using Differential Scanning Calorimetry

Yang and Steinberg (Ref 50) obtained generalized expressions for the kinetic parameters from a single DTA curve by the integration of the equation

$$dx/dt = A(1-x)^n \exp - (E_a/RT) \quad (5.4)$$

in what is in effect a revised Kissinger treatment (Ref 7). Because a peak ΔT is required, the method does not appear to be promising for the thermal analysis of all expls, although it may be of value in the study of solution kinetics

The thermal decomn of HMX was studied by Maycock and Pai Verneker (Ref 27) in flowing and stagnant He atms. Isothermal data were analyzed and compared with those obtained by the Kissinger (Ref 7) method. In earlier papers, Rogers and Smith (Ref 17) and Rogers and Morris (Ref 15) described the use of DSC in the study of first order reaction kinetics of several expls. DSC was used by Kishore (Ref 51) to perform an isothermal decomn study of RDX in open and closed sample holders. He showed that the decomn mechanism changes with confinement of the product gases and that the activation energy is decreased in closed pan tests due to autocatalysis

One of the important limitations in the use of DSC for the study of expls is that decomn is often accompanied by, or is a consequence of, melting or sublimation. Data analysis of such systems results in kinetic orders which have no significance. The problem was examined by Rogers (Ref 32) who noted that organic expls decomn normally more rapidly in the melt and, therefore, show very high apparent activation energies and preexponential factors, and that, therefore, compds which decomn without autocatalysis decomn in a DSC at a rate which is max when the melt is complete. For this reason Rogers used only the data above the ΔT_{max} peak. He performed the decomn isothermally and ob-

(*) Anon, "The Determination of Specific Heat with the Mettler TA 2000 System", Mettler Application Bull 1.5225.73A

tained the fraction reacted by graphical or mechanical integration of the areas under the DSC curves. Later, Rogers showed that additional contributions to the DSC thermogram arose from the decompn of the expl in the vapor phase (Ref 36), and he demonstrated a method for making the necessary correction

Rogers and Smith (Ref 28) discussed the general problem of applying DSC data to the study of chemical kinetics and they conclude that thermochemical techniques can only be used with "simple", ie, not consecutive, reactions. It appears, however, that much of the uncertainty which afflicts DSC data is due to phase changes which can be overcome by the use of combined TG-DTG, as will be shown in the next section

Summarizing, one finds that DSC is a suitable technique for thermochemical studies of equilibria and kinetics in the absence of phase changes. DSC may be used with confidence for the traditional multiple isothermal determination of reaction rates, but the particular elegance of the technique, albeit at the expense of the high degree of precision of other calorimetric techniques, resides in so-called programmed methods, ie, those which are designed to determine all kinetic parameters from a single thermogram

5.3.3 *By Combined Thermogravimetry and Differential Thermogravimetry*

Thermogravimetry (TG) analysis consists of heating a weighed sample at a programmed rate and recording the resulting weightloss. The sigmoid thermogram constitutes the integral of the weightloss or reaction rate so that suitably determined fractions of the areas subtended between the base line and the thermogram invite kinetic analysis of the reaction:

$$dw/dt = Aw^n \exp - (E_a/RT) \quad (5.5)$$

where 'w' is the fraction of the sample unreacted

This technique is obviously a suitable one for the study of reactive systems in which the products of the reaction are partially or completely gaseous, unless, of course, the weightloss is brought on by sublimation. By reducing the temp, or by reducing the heating rate, the decompn rate can be reduced so that the precision of the data acquisition can be enhanced. As with differential calorimetry, weightloss curves can be obtained isothermally or in a programmed manner. It is the use of the programmed rate of heating which gives thermogravimetry its greatest

utility in data analysis of reactive systems

The classic method of TG is to measure the weightloss, w, followed by manual differentiation. By use of a derivative computer, dw/dt is obtained directly. Determination of dw/dt at several temps permits computer programmed curve fitting and determination of A, E and n with high precision over any portion of the thermogram. In this manner changes of mechanism with changing temp can be detected, and by change of heating rate, complex reaction can be analyzed (Ref 53)

6.0 Analytical Tools

6.1 *Gas Chromatography*

Gas chromatography, especially in conjunction with mass spectrometry, has become an important tool for the separation and identification of the decompn products of expls and proplnts. For this purpose the techniques of gasometric analysis described in Vol 6, G15-R to G16-R have been largely superseded. A cursory description of gas chromatography is found in Vol 3, C289-L to C298-L. Since the publication of that volume (1966), the technique has seen great improvements in speed, reproducibility and convenience thru the development of microcapillary columns, while the precision has improved several orders of magnitude thru improved detection methods such as flame ionization which may be augmented by mass spectrometers and spectrophotometers

Gas chromatography for the study of equilibria in expls technology is limited by the tendency of expls to decomp in the columns, or by their nonvolatility. Expls which do not vaporize (ie, salts), must be derivatized, resulting in further complexity in the analysis of the data

6.1 *Liquid Chromatography*

Qual and quan identification of expls is often fraught with difficulty owing to the inherent thermal instability of the compds which limits the use of vapor phase analytical techniques. If the expl is present in reasonably pure and concd form, infrared spectroscopy is suitable. Many times, especially if the expl is present in trace amts (microgram quantities) or if it is diluted with fillers (as in proplnts), separation and concn prior to identification are required. The earlier method, thin layer chromatography,

is slow and it does not lend itself readily to quantization

Recent advances in liq chromatography appear to have solved some of the earlier difficulties. The technique involves the injection of a soln of the unknown mixt onto a packed absorption column at moderately high operating pressure, hence the term "high pressure liquid chromatography" (HPLC). The absorbed material is stripped using another solvent, the "mobile phase", which is analyzed using a refractometer or a spectrophotometric detector. The resultant signal is displayed on a strip chart recorder. Characterization of the unknown is, as with GC, thru measurement of the retention time. The sensitivity in terms of quantity required for detection is about three orders of magnitude lower than that of gas chromatography

Liq chromatography is conducted at ambient temps. Therefore, efficient separation and identification of chemically sensitive materials is now state of the art. Liq chromatography of NG, TNT, HMX and RDX using dichloroethane as solvent and 2% isopropanol in heptane as eluent has been reported (Ref 52). Separation of RDX from HMX was demonstrated using 40% 1,2 dichloroethane in heptane. The use of HPLC for the study of unstable compds is still in its infancy and major advances in the technique are anticipated

6.3 Mass Spectrometry

Until recently, mass spectrometric analysis (see Vol 8, M19-L to M39-R) of expls has been primarily conducted using electron impact (EI) ionization. However, under EI conditions, unstable compds undergo considerable fragmentation and in expl studies, the NO_2^+ ion constitutes the principal fragment while the molecular ion is usually lost in the process. Vouros et al (Ref 52) showed that by using ammonia as the reagent gas for chemical ionization mass spectrometry of TNT, RDX, HMX and NG, sufficient signals of the molecular ion are obtained to permit identification. An example of the use of chemical ionization for the identification of RDX was illustrated earlier (Vol 8, M26). The principle problem in using a mass spectrometer for the study of expls remains the difficulty of sample introduction which requires that the expl have a slight vapor pressure below its decompn

temp. Non-volatile expls may require derivatization or the use of a spark source

The potential storage of the mass spectrometer output in digital form has made possible the matching of mass fractograms against computer file stored reference data and hence the rapid identification of the material so that multi-component systems, after prior separation by GC or LC techniques, can be analyzed within the time frame required for the thrupt of the sample

6.4 Thermal Analysis

Thermal methods of analysis are defined as those techniques in which dependence of a property of a substance is measured as a function of temp. Techniques of interest for thermochemistry depend on weight changes or energy changes. These are defined briefly as follows: *Thermogravimetry (TG)* – A technique whereby the weight of a substance, in an environment heated or cooled at a controlled rate, is recorded as a function of time or temp. The record is the thermogravimetric or TG curve

Derivative Thermogravimetry (DTG) – A technique yielding the first derivative of the TG curve

Isothermal Weight-Change Determination – A method of obtaining a record of the dependence of the weight of a substance on time at constant temp. The record is the isothermal weight-change curve

Differential Thermal Analysis (DTA) – A procedure for recording the difference in temp between a substance and a reference material, against either time or temp as the two specimens are subjected to identical temp regimes in an environment heated or cooled at a controlled rate. The record is the differential thermal or DTA curve; the temp difference (ΔT) is usually plotted on the ordinate with endothermic reactions downward and time or temp on the abscissa increasing from left to right

Differential Scanning Calorimetry (DSC) – A means of recording the energy necessary to establish zero temp difference between a substance and a reference material, as for DTA. The record is the DSC curve; it represents the amount of heat applied per unit time as ordinate against either time or temp as abscissa

In the USA three manufacturers of program-

mable thermoanalytical equipment dominate the market. Perkin Elmer (*) is the original developer of the power compensated DSC concept permitting direct measurement of the differential power input to each pan. The current instrument (1979), the DSC-2, operates from 50–725°C with a subambient operating capability. Thermogravimetry is performed by a separate instrument, the TGS-2, operable to 1000°C with a DTG capability

The DuPont Company (**) provides an array of thermoanalysis modules which are operated from a central controller, the 990 Thermo Analysis System. The DSC cells operate on the heat flux principle from –190 to 725°C, at ambient, reduced and high pressures up to 1600psia in controllable atms. Various DTA modules can be operated from ambient to 2400°C. A separate TG module is operable to 1200°C with a DTG capability

The Mettler Instrument Corporation (***) is the only source of an instrument with a simultaneous DSC–TGA–DTG capability, the TA 2000C, which can operate on a single specimen from ambient to 1200°C (with 1600°C capability in development) at ambient and reduced pressures in normal and corrosive atms. The Mettler Instrument Corporation has other instruments with subambient temp and high pressure capabilities

All manufacturers offer computer software in various degrees of sophistication, most of which are at present in a state of development. The instruments are microprocessor controlled, provide differentiation, integration, disc storage of data and data analysis

6.4.1 Differential Thermal Analysis

Differential Thermal Analysis is the preferred technique for the study of high temp transitions, impurity determinations, and below ambient temp investigations because the temp sensors may be placed directly into the sample and because cell module designs are possible which can function at very high temps (2400°C)

and at high pressures. Because the geometries of the specimen holders may be poorly controlled at extreme operating conditions, the output signal does not reflect necessarily the amt of energy transferred. Therefore the instrument requires calibration at the operating condition

6.4.2 Differential Scanning Calorimetry

Differential Scanning Calorimetry (DSC) produces data which resemble superficially those produced by DTA but whose area under the output curve is proportional to the total energy transferred from the sample. The signal is therefore proportional to the rate of energy transfer (dq/dt). The original DSC concept called for actual measurement of the differential energy transfer (the power compensated DSC). Limited sample sizes and temp ranges have brought about reliance on the heat flux DSC principle which relies on a controlled (reproducible) heat flow into and out of the sample pan, the temp sensors being external to the specimen. Because the thermal resistance between the sample pan and the pan support is constant, differential temps are directly proportional to differential heat flows. The calibration constant is determined for each instrument and is then applicable without the need for re-calibration prior to each run. DSC devices can operate in controlled atms, in vacuum and under pressure. The temp range has now been extended to 1600°C, and sample sizes may be as large as 6g

Heat capacities as function of temp can be determined directly from the output signal from weighed specimens without the need of a separate calibration (see Sect 5.2.3). Enthalpies are obtained from the integrated areas under the DSC curve, as can the fraction of sample reacted which is proportional to the fraction of the area generated with time or temp. Likewise, reaction temps, initiation temps and the role of catalysts on mixts can be observed directly. The use of DSC for kinetic studies of reactive materials is limited by the tendency of such materials to undergo sublimation or melting. Suitable corrections can be applied to the data by the simultaneous use of TG. The role of impurities and of decompn products in promoting autocatalysis can be investigated by the use of reactive atms or reduced pressures as illustrated by the use of open (perforated) and closed sample pans (Ref 51)

(*) Instrument Division, Perkin Elmer Corporation, Norwalk, Conn 06852

(**) E.I. DuPont de Nemours & Co, Inc, Instrument Products, 1500 South Shamrock Avenue, Monrovia, Calif 91016

(***) Mettler Instrument Corporation, Princeton-Hightstown Road, Hightstown, NJ 08520

6.4.3 Thermogravimetry

Early devices for thermogravimetric analysis were limited in precision and convenience when compared with DTA or DSC equipment. Now devices for simultaneous DSC and TG are on the market which can operate at high temps in reactive atms permitting the simulation of high temp reactions on a micro scale. The use of TG for the study of reaction kinetics was described in Sect 5.3.3. An exptl study of the sublimation of ammonium perchlorate was published by Jacobs and Jones (Ref 25). Similar techniques should find application in the study of other propnt systems. The product gases have been collected for further analysis using gas chromatography and mass spectrometry

6.4.4 Differential Thermogravimetry

Differential thermogravimetric records can be generated electronically, obviating the laborious and inaccurate need for mechanical slope reading when reaction rates are under investigation. In the analysis of DSC data, DTG helps to distinguish phase changes from weight losses which are brought about by chemical reactions

6.5 Application of Infrared Spectroscopy to Thermochemistry

In addition to identifying molecular structure of expls, infrared spectroscopy has served to determine reaction rates by monitoring changes in the magnitude of absorption peaks with time. Visible spectra of flares containing Mg as fuel and Na nitrate and iodate as oxidizer have been examined for molecular emission (Ref 38). Computer programmed, automated high speed mapping techniques and optical scanning were applied to spectroscopic analysis of transient combustion and pyrot processes (Ref 49)

Great advances have occurred in the application of IR techniques to the study of transient phenomena, in the quant identification of trace contaminants and in the resolution of the spectra of mixts. The new techniques are known as Fourier Transform spectrometry. The following description will be necessarily brief but it is intended to highlight potential new areas of application in the study of rapid reaction phenomena:

"The limiting aspect of infrared spectroscopy is the available energy per unit time. The infrared sources are black bodies and as such are hot wire emitters. Infrared detectors such as thermocouples

or photoelectric devices have a relatively high internal noise compared with phototubes. Therefore, spectrometers should have a high energy thrupt since they suffer from energy limited sources and noise limited detectors.

Monochromators, using either gratings or prisms as dispersers, allow the observation of a narrow, predetermined nearly monochromatic frequency domain. Spectra are recorded by scanning the desired frequency range at successive resolution intervals. The narrow openings of the entrance and the exit slits limit the energy thrupt so that the detector views only a small frequency portion of the energy emitted by the source. Measurable signals are achieved by increasing the time of measurement per frequency interval. As the resolution is increased by narrowing the slits, the scanning rate is substantially decreased. Geometric dispersion in monochromators results in throwing away most of the valuable energy." (Ref 44)

Instead of one of the above-described monochromators, the Fourier Transform Infrared Spectrophotometer (FT-IR) employs a Michelson interferometer. The use of the interferometer produces two principle advantages: high energy thrupt and multiplexing. No slits limit the incoming energy so that the energy thrupt is 80-100 times greater than for a dispersion instrument. The multiplexing advantage is gained by the manner of interferometric scanning; a movable mirror varies continuously the path length of the light beam causing all frequencies to undergo interference. Consequently, each frequency has a characteristic interference pattern. The detector views all of the frequencies all of the time during the mirror movement which itself is precisely indexed with a second laser interferometer. The resulting interferogram requires further processing before a spectrum is obtained — but such a transformation need not be performed until all scans have been completed with a resulting gain in resolution, speed and sensitivity. The transformations are performed with a dedicated computer system. The interested reader is asked to consult the voluminous technical literature on the complex subject of Fourier transformation by the Cooley-Tukey algorithm (Refs 44 & 58). Commercial FT-IR devices are manufd in the USA by the Nicholet Corp and by Digilab, Inc. Several applications of

FT-IR to the thermochemical study of reactive systems are described below

6.5.1 Spectra of Transient Species

The emission spectrum of a nuclear fireball was measured for the first time using an airborne FT-IR (Ref 46)

6.5.2 GC-FT-IR

Rapid scanning interferometers can be used to measure spectra of peaks eluting from a gas chromatograph without prior trapping of the sample (Ref 58)

6.5.3 LC-FT-IR

Little has been published on the use of FT-IR to identify the peaks obtained from an on-line HPLC, but the obvious compatibility of the HPLC with the unstable intermediates of expl decompn suggests that this analytical technique will be extensively explored in the future. The difference spectroscopy (see below) possible with the FT-IR would allow subtraction of the spectrum of the mobile phase and so afford a measure of sensitivity not available with any other technique

6.5.4 Study of Reaction Kinetics

"In the past kinetic information has been acquired using infrared prisms and grating spectrophotometers by measuring the variation of absorbance of a single band as a function of time. This technique allows only one component to be monitored during a reaction. With a rapid scanning FT-IR spectrometer, complete interferograms can be measured over the entire frequency range at approximately one second intervals so that the variation of absorbance of bands due to all components can be monitored as a function of time. For rapid reactions each successive interferogram is processed but for slower reactions, several interferograms are signal averaged before they are stored." (Ref 58)

Liebman et al (Ref 47) have studied the formation of pyrolysis and combustion products as a function of time. Recently, very fast reactions have been studied by FT-IR using *time-resolved spectroscopy* (Ref 55). This method was first used to study the relaxation of vibrationally excited CO₂. Rapid scanning interferometers are now being modified in order that reactions with half times of much less than 1 ms can be studied. Using this technique it is possible to measure the spectrum of components that are present in flow thru reaction vessels as shortly

as 50 μs after the initial excitation

6.5.5 Difference Spectroscopy

Because most FT-IR spectrometers have a computerized data system as an integral component of the instrument, it is a relatively simple matter for programs to be written that operate on spectra as soon as they have been computed from the interferogram. One of the most important of these programs is the *scaled absorbance subtraction routine*. This program can be used to achieve the same result as placing a sample in the reference beam of the spectrometer, but the thickness of the reference cell or sample does not need to be controlled as accurately

6.5.6 Emission Spectroscopy

Infrared emission spectroscopy can be used for the laboratory study of heated samples as one would encounter in pyrot reactions or in the detonation of primary expls. One difficulty associated with the measurement of emission spectra of condensed phase samples is that the temp of the sample has to be uniform, or else radiation emitted from elements situated below the surface will be absorbed by the cooler particles near the surface. Emission spectrometry finds application in the study of flames and smoke

Further applications of spectrometry to explosive and pyrot phenomena are listed under the entry, "Spectroscopy of Energetic Materials", in this Vol

6.6 Pyrometry

The determination of electronic temps (energies) and black body temps in pyrot and expl events remains an important practical problem in the exptl study of the thermochemistry of high energy reactions. Instrumental difficulties inhibit, for instance, the study of energy transfer from the primary expl charge in primers to the proplnt. An interesting development of a three-color pyrometer was reported by Demeter and Childers (Ref 48) which is said to resolve transient temps in submicrosecond time frames. Examples of such events are exploding bridge wires (Ref 37), burning flash bulbs and energy deposition from Q-switched lasers

Many pyrot reactions take place by the formation of metallic oxides whose emissivity varies strongly with wavelength (Ref 9). As long as the emissivity is reasonably constant over the temp range investigated (ie, as long as the grey body

assumption is valid), two color pyrometry will afford an accurate temp reading

In optical pyrometry the size of the luminous object must meet a certain minimum, and the radiant energy output must be uniform over the area observed, lest the apparent temp be low. Moreover, temp readings will be low if radiant energy is absorbed in the colder outer gas envelope. The role of smoke and other debris in the study of expls was alluded to in an earlier article ("Spectroscopy of Energetic Materials" in this Vol). There, too, was referenced rapid scan spectroscopy for the resolution of pyrot phenomena, and of the energetics of fuel-air expls. For more extensive discussions of high temp measurement techniques, see Ref 6a

Obtaining high light output efficiency from pyrot devices continues to be a major problem. The cause of low flare efficiencies is, aside from the loss incurred from internal absorption due to smoke, that the light output originates from the excited state in atoms and molecules which decay to the groundstate. This excitation derives its energy thermally such that the portion of the energy which is not in the desired frequency range is lost. Attempts have been made to enhance the flare efficiency by generating the excited state thru the use of Na iodate as oxidizer (Ref 39), but without success. The emission from the Na D line accounts for most of the light output in Mg-Na nitrate flares, whereas the Mg vapor flame is the principle source of heat. This is the reason why fuel rich formulas produce more light than stoichiometric mixts (Ref 29). Attempts to substitute Al for Mg was found possible if moisture was rigorously excluded from the mixt (Ref 41). The whole rather complex relationship between the thermal and the luminous output of the flare, its size and its thermochemical energy was reviewed by Tanner (Ref 45). Time integrated spectra from various pyrot flames have been measured and the light absorption by smoke has been correlated with compn and ambient pressure (Ref 22). Eisel and Zurn (Ref 42) investigated the burning mechanism of Mg-Na nitrate flares using high speed motion pictures. This system resembles the Mg-Sr perchlorate tracer mixt studied by Hardt and Phung (Ref 40)

7.0 The Use of Thermochemistry In Hazard Assessment

7.1 Shock Initiation

We have seen in Sect 2.0 of this article that thermochemical parameters are no reliable guide for predicting the shock sensitivity of expls. For a quant determination of the shock required to initiate an expl or proplnt, one needs the appropriate Hugoniot (see under "Shock Sensitivity of Explosives" in this Vol, and under "Hugoniots" in Vol 7, H179-L to H184-R). Hugoniots are tabulated for several proplnts (Vol 8, P452) and for expls (Vol 7, H180-81). For pyrot mixts shock sensitivity is usually low but it is difficult to make a quant assessment because equations of state for the mixts are not available. An assessment of the problem was made by Hardt and Martinson (Ref 35)

The uses of thermochemical data in estimating heats of detonation, detonation product compns, fire and expln hazards and critical diameters for expls were reviewed earlier (Vol 7, H38-L ff). For instances where heats of formation of organic expls are lacking, their estimation from group activities was described in Vol 7, H47-L ff

A method for linking thermochemical data to the prediction of hazards was presented in Vol 7, H15-L to H23-L. The reader is directed to this article for a discussion of the complexity of the subject. For a further exposition of the problem, see "Safety in the Energetic Materials Field" in this Vol

7.2 Thermal Initiation

Expls and proplnts decomp exothermally at every temp above absoluté zero. If the mass of the material is such that the heat produced by the decompn cannot be dissipated as rapidly as it is produced, the mass will heat itself to expln. The lowest constant surface temp above which a thermal expln is initiated is a function of the size, thermal conductance, the heat of reaction, and the reaction kinetic parameters. The calcn of this critical temp was presented in this Vol in the article, "Safety in the Energetic Materials Field", and by Rogers (Ref 43)

7.3 Evaluation of New Explosives and Explosive Mixtures

Techniques and instrumentation for the evaluation and experimentation with reactive materials of unknown properties were reviewed also in the article on "Safety in the Energetic

Materials Field". A detailed listing of the thermochemical and hazard characteristics of PBX compns were tabulated in Vol 8, P68 to P74 (Tables 3 to 5)

8.0 Sources of Thermochemical Data

8.1 Explosives

Thermochemical data on expls are well documented in this Encycl and elsewhere. The heats of combustion and of expln are listed in Vol 4, D380 to D-381. The Standard Heats of Formation and the Heats of Detonation of common expls are found in Vol 7, H41 to H43, those of nitroalkanes in Vol 7, H54. The heats of phase change are tabulated in Vol 7, H44, and the thermal conductivities and specific heats in Vol 7, H45 to H46. The Free Energy Functions of the Detonation Products were listed in Vol 8, P388. A discussion of the thermochemical and detonation characteristics of liq expls are tabulated in Vol 7, L26-L to L34-R. Important

compilations are found in the Engineering Design Handbook Series (Ref 34) and in Urbański's books (Ref 16). Note also the entry under "Power of Explosives" in Vol 8, P364-L to P366-R

8.2 Propellants

Reports on the thermochemistry of proplnts are numerous but widely scattered. The distinction between gun proplnts and rocket proplnts must here be kept in mind. The use of the English units of measurement is still firmly entrenched, but as the impact of a change to the SI system on the numerical values will be slight, this change is to be expected soon

Solid proplnts and their thermochemistry were reviewed in a major article in Vol 8, P402-L to P473-L. Liq proplnts have been reviewed in an earlier volume (Vol 7, L34-L to L44-R) as well as by Barrère (Ref 10) and Sutton (Ref 14). The properties of solid proplnt components such as metals, hydrides, non-metallic and metallic

Table 2
Thermochemical Data Sources For Pyrotechnic Reactions
(Numbers Refer to Citations *under Refs*)

	<u>Elements</u>	<u>Oxides</u>	<u>Halides</u>	<u>Nitrides</u> <u>Carbides</u>	<u>Nitrates</u> <u>Chlorates</u> <u>Perchlorates</u>	<u>Sulfides</u> <u>Silicides</u> <u>Phosphides</u>	<u>Alloys</u>
ΔH_f^{298}	—	12, 31	12, 31 2, 3	12, 31	13, 23	3	33, 6
$(H_T - H_{298})$	3, 31, 2 33	31, 12	12, 31, 2 2, 3, 12	12, 31	13	—	33
$(S_T - S_{298})$	2, 3, 4 31, 33	31, 12	2, 3, 4 12, 31	12, 31	13	—	33
$(F_T - H_f^{298})$ T	3, 31 12, 33	31	—	31	13	—	33
T_m	3, 12, 31, 31, 33	31	3, 31	3, 12	13	3	33
H_m	3, 31, 33	31	3, 12, 31	—	13	—	33
T_b	3, 12, 31 33	31	3, 12, 31	12	13	—	33
H_b	3, 31, 33	31	3, 12, 31	—	13	—	33
ΔF_f^{298}	—	31	31, 3, 12	3, 12, 31	23	3	6, 33
S_f^{298}	—	31	3, 31	3, 31	13, 23	3	6, 33

nitrate, of glycol nitrate esters and of perchlorates are listed in Vol 8, P441 to P444. The calorimetry of propolnts was described in Vol 2, C9-L to C12-R

The role of the heat of expln of gun propolnts on bore wear was discussed in Vol 8, P405-R. Exhaust gas compns of composite propolnts were tabulated in Vol 8, P410-L, the heats of expln for double base, NC based and composite propolnts was listed in Vol 8, P 408-L to P418-R. The role of burning rate modifiers is described in Vol 8, P430-L to P439-L

8.3 Pyrotechnic Compositions

Table 2 lists the major sources for thermochemical data of the reactants and products which are likely to be encountered in pyrot calcns. This Encycl lists some of the properties in Vol 8, P441 to P444

Written by A. P. HARDT

Lockheed Missiles and Space Company, Inc.

Refs: 1) W.F. Giaque, "The Calculation of Free Energy from Spectroscopic Data", JACS 52 (1930), 4808 2) K.K. Kelley, "Contributions to the Data on Theoretical Metallurgy", US Bu-Mines Bull 476 (1949); & Bull 584 (1960) 3) L.L. Quill, Ed, "The Chemistry and Metallurgy of Miscellaneous Materials", McGraw-Hill, NY (1950) 4) K.K. Kelley, "Contributions to the Data on Theoretical Metallurgy", US Bu-Mines Bull 477 (1950) 5) C.L. Johnson, Anal-Chem 24 (1952), 1572 6) O. Kubaschewski & J.A. Catterall, "Thermochemical Data of Alloys", Pergamon Press, London (1956) 6a) I.E. Campbell, Ed, "High Temperature Technology", J. Wiley & Sons, NY (1956), 335 7) H.E. Kissinger, AnalChem 29 (1957), 1702 8) E.S. Freeman, "The Kinetics of the Thermal Decomposition of Potassium Nitrate and of the Reaction Between Potassium Nitrite and Oxygen", JACS 79 (1957), 838-42 9) H. Ellern, "Military and Civilian Pyrotechnics" Chemical Publishing Co, NY (1968), 91 10) M. Barrère et al, "Rocket Propulsion", Elsevier, Amsterdam (1960), 640-43 12) C.E. Wicks & F.E. Block, "Thermodynamic Properties of 65 Elements, Their Oxides, Halides, Carbides and Nitrides", US BuMines Bull 605 (1963) 13) Anon, EngrgDesHndbk, Military Pyrotechnics Series, "Properties of Materials Used in Pyrotechnic Compositions", AMCP 706-187 (1963)

14) G.P. Sutton, "Rocket Propulsion Elements", 3rd Ed, John Wiley & Sons, NY (1963), 206-11 15) R.N. Rogers & E.D. Morris, Jr, "On Estimating Activation Energies with a DSC", Anal-Chem 38 (1966), 412 16) T. Urbański, "Chemistry and Technology of Explosives", Pergamon Press, NY (1967) 17) R.N. Rogers & L.C. Smith, "Estimation of the Pre-Exponential Factor from Thermal Decomposition Curves of an Unweighed Sample", AnalChem 39 (1967), 1024-37 18) Anon, EngrgDesHndbk, Military Pyrotechnics Series, Part 1, "Theory and Application", AMCP 706-185 (1967) 19) B.J. McBride & S. Gordon, "Fortran IV Program for the Calculation of Thermodynamic Data", NASA TN D-4097, Lewis Research Center, Cleveland (1967); Available NTIS N67-35192 20) T.J. Hauser and B.M.H. Lee, "Pyrolysis Kinetics of Ethyl Nitrate", JPhys-Chem 71 (11) (1967), 3422-26 21) D.L. Ornellas, JPhysChem 72 (1968), 2390. See also: D.L. Ornellas et al, RevSciInstr 37 (1966), 907 22) R.M. Blunt, "Study Spectra of Metal Oxidant Combinations", DRI-3976-6803 F (1968) (AD 673 976) 23) D.D. Wagman et al, "Selected Values of Chemical Thermodynamic Properties", US Dept of Commerce Tech Notes 270-3 and 270-4 (1968, 1969) 24) F.J. Zeleznik & S. Gordon, "Calculation of Complex Chemical Equilibria", IEC 60 (6) (1968) 25) P.W.M. Jacobs & A.R. Jones, "Sublimation of Ammonium Perchlorate", JPhysChem 72 (1968), 202-07 26) H.P. Marshall et al, JPhysChem 69 (1965), 25; & Ibid 72 (1968), 1513 27) J.N. Maycock & V.R. Pai Verneker, "Thermal Decomposition of δ HMX", Explosivst 1 (1969), 5-8 28) R.N. Rogers & L.C. Smith, "Application of Scanning Calorimetry to the Study of Chemical Kinetics", Thermochim-Acta (1970), 1-9 29) R.M. Blunt, "Flare Flame Phenomena", RDTR No 186, Naval Ammo Depot, Crane, Indiana (1971) (AD 729 104) 30) S. Gordon & B.J. McBride, "Computer Program for Calculation of Complex Chemical Equilibrium Compositions, Rocket Performance, Incident and Reflected Shocks, and Chapman-Jouguet Detonations", NASA SP-273, Lewis Research Center (1971); Available NTIS N-71-37775 31) Anon, "JANAF Thermochemical Tables", NSRDS - NBS 37, Dow Chemical Co, Midland, Mich; Available

- from US Govt Printing Office, Wash, DC 20402, Catalog No C13.48:37. Loose Leaf Supplement and Magnetic Tape available from Dow Chemical Co, Midland, Mich, Thermal Research Laboratory
- 32) R.N. Rogers, "Differential Scanning Calorimetric Determination of Kinetic Constants of Systems that Melt with Decomposition", *ThermochimActa* **3** (1972), 437-47
- 33) R. Hultgren et al, "Selected Values of Thermodynamic Properties of Metals and Alloys", J. Wiley & Sons, NY (1963), Supplements available from the Univ of California, Berkeley (1972)
- 34) Anon, *EngrgDesHndbk*, "Principles of Explosive Behavior", **AMCP 706-180** (1972)
- 35) A.P. Hardt & R.H. Martinson, "Initiation of Pyrotechnic Mixtures by Shock", *Proc 8th Symp Expls & Pyrots*, Franklin Inst (Feb 1974)
- 36) R.N. Rogers, "Determination of Condensed-Phase Kinetic Constants", *ThermochimActa* **9** (1974), 444-46
- 37) R.D. Sacks & J.A. Holcombe, "Radiative and Electrical Properties of Exploding Silver Wires", *JApplSpectr* **28** (6) (1974), 578
- 38) B.E. Douda & E.J. Bair, "Radiative Transfer Model of a Pyrotechnic Flame", *JQuantSpectrRadiatTransfer* **14** (1974), 1091-1105
- 39) H.A. Webster III & C.W. Gilliam, "Spectral Characteristics of Flares Containing Sodium Iodate as Oxidizer", **NAD-RDTR-276** (1974) (AD 782510)
- 40) A.P. Hardt & P.V. Phung, "Study of Reaction Mechanisms in Tracer Munitions", **FA-TR-74047** (1974)
- 41) B. Jackson et al, "Substitution of Aluminum for Magnesium as a Fuel in Flares", **PATR 4704** (1975) (AD A013360)
- 42) J.L. Eisel & D.E. Zurn, "Physicochemical Details at the Surface of Burning Illumination Flares", **NWC-TP 5726** (1975)
- 43) R.N. Rogers, "Thermochemistry of Explosives", *ThermochimActa* **11** (1975), 131-39
- 44) L. Koenig, "Application of Fourier Transform Infrared Spectroscopy to Chemical Systems", *ApplSpectrosc* **29** (4) (1975), 293
- 45) J.E. Tanner, "A Mathematical Model of Flare Plume Combustion and Radiation", **NWSC/CR/RDTR-9**, Nav Weapons Supply Center, Crane, Indiana (1975)
- 46) L.V. Azarraga, "Improved Sensitivity of On-The-Fly GC-IR Spectroscopy", Paper No 334, Pittsburgh Conf Anal Chem Appl Spec, Cleveland, Ohio (1976), cited in Ref 58
- 47) S.A. Liebman et al, *ApplSpectrosc* **30** (1976), 355
- 48) L. Demeter & K. Childers, "Optical Pyrometer for Submicro-second Temperature Measurements", **DNA 3177 T**, Physics International Co, San Leandro, CA (no date)
- 49) M.B. Denton, "Investigating Mapping Techniques for Elucidating Processes Occurring in Pyrotechnic Flames and Their Flame Envelope", Final Report, Contract N00019-76-C0510 (1977)
- 50) R.T. Yang & M. Steinberg, "Differential Thermal Analysis and Reaction Kinetics for nth Order Reactions", *AnalChem* **49** (1977), 998
- 51) K. Kishore, "Thermal Decomposition Studies on RDX by DSC", *Proplnts-&Expls* **2** (1977), 78-81
- 52) P. Vouros et al, "Analysis of Explosives by High Performance Liquid Chromatography and Chemical Ionization", *AnalChem* **49** (7) (1977), 1039-44
- 53) R.W. Mickelson & I.N. Einhorn, "Kinetic Interpretation in Thermogravimetric Analysis", *Combustn&Flame* **28** (1) (1977), 45-61
- 54) L.W. Collins & L.D. Haws, "The Thermochemistry of Explosives—A Review", *ThermochimicaActa* **21** (1977), 1-38
- 55) A. Mantz, "Time Resolved Spectroscopy" in "Fourier Transform I.R. Application to Chemical Systems", J.R. Ferraro & L.J. Basilo, Eds, Academic Press, NY (1978)
- 56) J.E. Tanner, Jr & J.J. Angotti, "A Modification of the NASA PAC-2 Code to Read Input from Tape", Naval Weapons Support Center, Appl Sciences Dept, Crane, Indiana 47522 (Sept 1978)
- 57) S. Sunner & M. Månsson, "Combustion Calorimetry, Experimental Chemical Thermodynamics", Vol 1, Pergamon Press, Oxford (1979)
- 58) P.R. Griffiths, "Transform Techniques in Chemistry", Plenum Press, NY (1979)

Thermodynamics

"The fascination of a growing science lies in the work of the pioneers at the very borderland of the unknown, but to reach this frontier one must pass over well travelled roads; of these one of the safest and surest is the broad highway of thermodynamics"

—G. N. Lewis

Thermodynamics is a branch of science used by chemists, physicists and engineers. It deals primarily with the interrelation and transfer of various forms of energy. It is an exact mathematical science, based upon a small number of basic premises or postulates from which all its conclusions are deduced by logical processes. Most of its methods are based on the macroscopic exptl point of view. Thus thermodynamics is free from the uncertainties that beset other sciences that are based on microscopic considerations. From its inception a little over a century ago, thermodynamics has been associated with many of the famous names in science: Gibbs, LeChatelier, Boltzmann, Helmholtz, Van'tHoff, Haber, Nernst, G.N. Lewis, Debye and Onsager, to name just a few

To treat the subject of thermodynamics adequately would require a whole book, nay indeed a whole encyclopedia. In this article we will present a cursory overview of thermodynamic concepts and refer the reader to standard texts on the subject. Much of the article will be concerned with applications of thermodynamics to expln phenomena and its use, in conjunction with *hydrodynamics*, in explaining shock and detonation processes

General Considerations and Definitions

A *thermodynamic system* (closed system) is one that interacts with the surroundings by exchanging heat and work thru its boundary; an *isolated system* is one that does not interact with the surroundings. The *state* of a system is determined by the values of its various properties, eg, pressure, volume, internal energy, etc. A system can be composed of a finite number of homogeneous parts, called *phases*, or there can be a single phase. For some applications, it may

be necessary to consider the finite number of nonhomogeneous regions forming the boundaries between pairs of homogeneous phases; for most cases, the extent of such regions is small and they can be neglected in comparison to the homogeneous regions. Some properties of the homogeneous phases are regarded as fundamental; eg, temp, internal energy, pressure, entropy and volume

Properties such as internal energy, volume and entropy are called *extensive* because their values for a given phase are proportional to the mass or volume of the phase. The value of an extensive property of an entire system is the sum of the values of each of the constituent phases. The *molar value* of an extensive property is that for a properly defined gram-molecular weight or mole of material. The *specific value* of an extensive property is that per unit weight (eg, one gram of material). A property is called *intensive* if its value for a given phase is independent of the mass of the phase. Temp and pressure are examples of such intensive properties

A *thermodynamic process* is said to have taken place if a change is observed to have taken place in any *macroscopic* property of the system. An *infinitesimal process* is a process in which there is only an infinitesimal change in any macroscopic property of the system. A *natural process* is an infinitesimal process that occurs spontaneously in real systems; an *unnatural process* is one that cannot occur spontaneously in real systems. *Reversible processes* are either natural or unnatural processes which can occur in either direction between two states of equilibrium

For in-depth discussions of thermodynamic concepts and applications, the reader is referred to Refs 4, 5, 12, 14 and 16. From a historical point of view the publications of Gibbs (Ref 1), LeChatelier (Ref 2), and Haber (Ref 3) are of interest. In Refs 11, 15 & 18 there are many applications of thermodynamics to detonation theory

The Laws of Thermodynamics and Thermodynamic Identities

The *first law* of thermodynamics for an isolated system can be stated as follows: There exists a function of the state of a uniform phase called the energy which is conserved for

any process over all the phases participating in the process. In effect this is the law of conservation of energy

The *second law* of thermodynamics for an isolated system can be stated as follows: There exists a function of the state of a uniform phase called the entropy which is conserved for any reversible process and which increases for any irreversible process over all of the phases participating in the process

For a reversible process in the k^{th} phase, the two laws may be combined to give:

$$dE^{(k)} = T^{(k)} dS^{(k)} - p^{(k)} dV^{(k)} \quad (1)$$

where E = internal energy, T = temp, S = entropy, p = pressure and V = volume. In the general case (reversible or irreversible processes in the k^{th} phase):

$$dE^{(k)} = T^{(k)} dS^{(k)} - p^{(k)} dV^{(k)} + M \sum_i \mu_i^{(k)} dn_i^{(k)} \quad (2)$$

where M = total mass of the system, μ_i = chemical potential of the i^{th} species (also called the partial molar free energy) and n_i = number of moles of the i^{th} species

Other important relations are:

Enthalpy (or heat content):

$$H^{(k)} = E^{(k)} + p^{(k)} V^{(k)} \quad (3)$$

Helmholz free energy:

$$F^{(k)} = E^{(k)} - T^{(k)} S^{(k)} \quad (4)$$

Gibbs free energy:

$$G^{(k)} = H^{(k)} - T^{(k)} S^{(k)} \quad (5)$$

From these basic equations a whole spectrum of useful *thermodynamic identities* may be derived by partial differentiation

Some examples of useful identities are given below. Capital letters designate *molar* quantities whereas lower case letters designate *specific* quantities. Subscripts below the brackets show which properties were kept constant in the derivation

Specific heat capacity at constant volume and at constant pressure:

$$c_v = T \left[\frac{\partial s}{\partial T} \right]_v$$

$$c_p = T \left[\frac{\partial s}{\partial T} \right]_p \quad (6)$$

The ratio c_p/c_v is usually designated by γ

If, in addition to pressure or volume, the compn is assumed to remain fixed during the heating process, the heat capacities are called

the heat capacities for constant compn, or more shortly, the "frozen" heat capacities. Thus

$$c_{v,n} = T \left[\frac{\partial s}{\partial T} \right]_{v,n}$$

$$c_{p,n} = T \left[\frac{\partial s}{\partial T} \right]_{p,n} \quad (7)$$

Here n is the total number of moles

Alternately, in terms of specific energy e or specific enthalpy h :

$$c_v = \left[\frac{\partial e}{\partial T} \right]_v, \quad c_{v,n} = \left[\frac{\partial e}{\partial T} \right]_{v,n}$$

$$c_p = \left[\frac{\partial h}{\partial T} \right]_p, \quad c_{p,n} = \left[\frac{\partial h}{\partial T} \right]_{p,n} \quad (8)$$

Other important equations relating entropy and pressure or volume are:

$$\left[\frac{\partial s}{\partial v} \right]_{T,n} = \left[\frac{\partial p}{\partial T} \right]_{v,n}$$

$$\left[\frac{\partial s}{\partial p} \right]_{T,n} = - \left[\frac{\partial v}{\partial T} \right]_{p,n} \quad (9)$$

The relations between specific energy, or specific enthalpy, and P , V and T are:

$$\left[\frac{\partial e}{\partial v} \right]_{T,n} = T \left[\frac{\partial p}{\partial T} \right]_{v,n} - P$$

$$\left[\frac{\partial h}{\partial p} \right]_{T,n} = v - T \left[\frac{\partial v}{\partial T} \right]_{p,n} \quad (10)$$

The chemical potential of the i^{th} gaseous or pure condensed phase species in terms of observable quantities is:

$$\left[\frac{\partial \mu_i}{\partial p} \right]_{T,n} = \bar{V}_i$$

$$\left[\frac{\partial \mu_i}{\partial \tau} \right]_{T,n} = -p_i$$

$$\left[\frac{\partial (\mu_i/T)}{\partial T} \right]_{T,n} = -E_i/T^2$$

$$\left[\frac{\partial (\mu_i/T)}{\partial T} \right]_{p,n} = -\bar{H}_i/T^2 \quad (11)$$

The quantities with a bar over them are partial

molar quantities. The quantity τ is defined as follows: Let v be the specific volume of a mixt of gaseous and condensed phases, V_j' the molar volume of the j^{th} condensed component, and τ the volume of the gas phase for unit weight of mixt. For a homogeneous system consisting of a gas phase only, $v = \tau$. In general

$$v = \tau + \sum_j n_j' V_j'$$

Since we have briefly introduced the consideration of mixed systems, we will mention, in passing, Gibbs' famed *Phase Rule*. Its basic equation, which is generally applicable, is:

$$F = C - P + 2$$

where F is the number of degrees of freedom in a closed system containing C components and P phases

Of great importance to the thermohydrodynamic interpretation of detonation phenomena (see Refs 11, 15 & 18) is the *equilibrium sound velocity*, c . For a perfect gas:

$$c^2 = (\partial p / \partial \rho)_s = \gamma p v, \text{ where } \rho = 1/v.$$

For a gas that obeys the so-called polytropic equation of state (EOS): $p/\rho^\kappa = \text{const}$ and

$$\kappa = -\left(\frac{v}{p}\right)\left(\frac{\partial p}{\partial v}\right)_s$$

For this gas,

$$c^2 = \left(\frac{\partial p}{\partial \rho}\right)_s = \kappa p v \quad (12)$$

The relation between κ and γ is

$$\kappa = -\gamma \left(\frac{v}{p}\right) \left(\frac{\partial p}{\partial v}\right)_T$$

Similar relations are obtained for the *frozen sound velocity*, c_n , except that

$$\kappa_n = -\left(\frac{v}{p}\right)\left(\frac{\partial p}{\partial v}\right)_{s,n}$$

must be used instead of κ .

In terms of derivatives of the EOS, c_n and c are given by:

$$c_n^2 = -v^2 \left[\left(\frac{\partial p}{\partial v}\right)_{T,n} - \frac{T}{c_{v,n}} \left(\frac{\partial p}{\partial T}\right)_{v,n}^2 \right]$$

$$\begin{aligned} &= -v^2 \left[\left(\frac{\partial v}{\partial p}\right)_{T,n} + \frac{T}{c_{p,n}} \left(\frac{\partial v}{\partial T}\right)^2 \right]^{-1} \\ c^2 &= -v^2 \left[\left(\frac{\partial p}{\partial v}\right)_T - \frac{T}{c_v} \left(\frac{\partial p}{\partial T}\right)_v^2 \right] \\ &= -v^2 \left[\left(\frac{\partial v}{\partial p}\right)_T + \frac{T}{c_p} \left(\frac{\partial v}{\partial T}\right)_p^2 \right]^{-1} \end{aligned} \quad (13)$$

Physically, the frozen sound velocity corresponds to the velocity of propagation of sound waves in a limit attained at high frequency, and the equilibrium sound velocity corresponds to the propagation velocity of sound waves in a limit attained at low frequency

Occasionally it is convenient to analyze an equilibrium system or a fixed compn system in terms of volume and entropy. In this case, the coefficients β and β_n (defined below) become useful:

$$\beta = \frac{v}{T} \left(\frac{\partial p}{\partial s}\right)_v \quad \text{and} \quad \beta_n = \frac{v}{T} \left(\frac{\partial p}{\partial s}\right)_{v,n}$$

If energy is to be regarded as a function of pressure and volume, additional coefficients λ and λ_n can be defined as follows:

$$\left(\frac{\partial e}{\partial v}\right)_{p,n} = \frac{p}{\lambda_n}; \quad \left(\frac{\partial e}{\partial v}\right)_p = \frac{p}{\lambda}$$

From other thermodynamic identities one obtains the following relation between the coefficients κ , β and λ :

$$\kappa = \beta \left(\frac{1}{\lambda} + 1\right)$$

An analogous relation exists between the corresponding coefficients for a system of fixed compn

The *third law* (also called the Nernst heat theorem) states that *all perfectly ordered crystalline substances have zero entropy at absolute zero temp*

Most of the thermodynamic functions (eg, H , F and G) can be defined only with reference to some standard state. Entropy, however, can be defined in absolute terms with the help of the third law

Chemical Equilibrium

In terms of the chemical potential, the condition for chemical equilibrium at constant temp and pressure is:

$$\left(\sum_i \mu_i dn_i\right)_{T,P} = 0 \quad (14)$$

For a closed system in which a chemical change occurs, the change in number of moles of each constituent is determined by the stoichiometry of the reaction. For any number of reactants and products:



when $c dn$ moles of C are formed, $a dn$ moles of A disappear, etc, so at equilibrium, Eq 14 becomes:

$$c\mu_C dn + \dots - a\mu_A dn - b\mu_B dn - \dots = 0$$

This requires that

$$c\mu_C + \dots - a\mu_A - b\mu_B + \dots = 0$$

Now it becomes necessary to evaluate changes in chemical potential with changes in compn and the relative values of the chemical potentials of the pure components. This will be done below

From the definition of μ_i for the *ideal gas*:

$$\mu_i = \mu_i^\circ + RT \ln P_i \quad (15)$$

where μ_i° is the standard-state chemical potential of ideal gas i at 1 atm, μ_i is the chemical potential at any other partial pressure, P_i . For real gases, the *fugacity* f_i must replace P_i . Fugacity is in effect a corrected partial pressure for real gases. It is defined according to:

$$dG = nRT d \ln f$$

or, at constant temp, in integrated form:

$$\Delta G = G_2 - G_1 = nRT \ln \frac{f_2}{f_1} \quad (16)$$

and

$$\frac{f}{P} = 1, \text{ in the limit as } P \rightarrow 0$$

At this stage, we digress briefly to define another concept useful in the treatment of condensed phases. The *activity*, a , is simply a relative fugacity, namely:

$$a = f/f^\circ$$

where f° is the fugacity in the standard state

which, for the condensed state, is not necessarily chosen as 1 atm. Note that a is dimensionless. For a complete discussion of fugacity and activity see Refs 5, 16 or 18

Eq 15 for condensed systems becomes:

$$d\mu_i = RT d \ln f_i = RT d \ln a_i \quad (17)$$

The change in free energy ΔG for any chemical process is determined by:

$$\Delta G = \left(\sum_{\text{prod}} n_i \mu_i\right) - \left(\sum_{\text{react}} n_i \mu_i\right)$$

From Eqs 14, 15 and 16 it can be shown that:

$$\Delta G^\circ = -RT \ln K_f \quad (18)$$

Here ΔG° is the difference in free energies of products and reactants in their *standard states*, and the equilibrium constant K_f is:

$$K_f = \frac{f_C^c \dots}{f_A^a f_B^b \dots}$$

Eq 18 is applicable to equilibrium constants in alternate form. For ideal gases the equilibrium constant K_p is expressed in terms of partial pressures (rather than fugacities) of products and reactants. Still another form of the equilibrium constant, K_x , is expressed in terms of mole fractions. It is applicable to *ideal gases* or *ideal solns*. The relation between K_p and K_x is:

$$K_p P_t^{-\Delta n} = K_x$$

where P_t is the total pressure and Δn is the change in the number of moles during reaction. For *real solns* the relation between K_p and K_x is complex

Statistical Thermodynamics

Many interesting and useful concepts follow from classical statistical considerations (eg, the Boltzmann distribution law) and their later modifications to take into account quantum mechanical effects (Bose-Einstein and Fermi-Dirac statistics). These concepts are quite beyond the scope of the present article, and the reader should consult Refs 14 & 16. A brief excursion into this area is appropriate, however. A very useful concept is the so-called *partition function*, Z , which is defined as:

$$Z = \sum_i g_i e^{-\epsilon_i/kT}$$

where ϵ_i is the energy of i^{th} species, k is the Boltzmann constant and g_i is a statistical weighting factor. Partition functions can be used to compute free energy values, entropies, etc. A most useful result of such computations, as far as detonation product calcs are concerned, is a set of ideal gas-free energy functions, $\Delta G^\circ/RT$, for the common detonation product gases at several elevated temps (see "Products, Detonation", Vol 8, P388)

Shock Equations and Thermodynamics

The basic equations across a shock front, derived from consideration of conservation of mass, momentum and energy, are:

$$u_1 = U(1 - \rho_0 v_1) \quad (19a)$$

$$p_1 - p_0 = \rho_0 u_1 U \quad (19b)$$

$$e_1 - e_0 = \frac{1}{2}(p_1 + p_0)(v_0 - v_1) \quad (19c)$$

It is immediately apparent that the energy equation (the Rankine-Hugoniot relation) is expressed entirely in terms of thermodynamic quantities. The particle velocity, u_1 , and shock velocity, U , can also be expressed completely in thermodynamic quantities. If the material ahead of the shock is at rest:

$$U = v_0 \sqrt{(p_1 - p_0) / (v_0 - v)} \quad (20a)$$

and

$$u = (v_0 - v) \sqrt{(p_1 - p_0) / (v_0 - v)} \quad (20b)$$

However, the solution of the above equations requires an additional relation between p and v . This is readily available for an ideal gas or one that obeys the polytropic EOS. For other systems the $p-v$ relationships are complex. Some of these will be examined briefly in a following section

Incidentally, a thermodynamic inequality determines whether a shock is stable, ie, whether it does break into several shocks or becomes a gradually rising wave. A shock is stable if the isentrope satisfies the condition:

$$\left(\frac{\partial^2 p}{\partial v^2} \right)_s > 0$$

The Chapman-Jouguet Condition

Fundamental to the development of detonation theory is the relation $D = u + c$, where D is the steady-state detonation velocity, u , is the steady-state particle velocity, and c the steady-

state sound velocity. Originally this relation was known as the Chapman-Jouguet (CJ) hypothesis. Scorah (Ref 6) used thermodynamic arguments in an attempt to prove that the state defined by the above relation is the most probable one.

However, Scorah's arguments were criticized by Zeldovitch (Ref 7). A more complete "proof" that may have advanced the CJ hypothesis to the status of a "condition" was given by Brinkley & Kirkwood (Ref 10), again thru the use of thermodynamic reasoning

Thermodynamic reasoning can also be used to characterize the unique properties of a CJ state on the Hugoniot curve of the detonation products. The entropy of the detonation products varies along the Hugoniot but attains a stationary value at the CJ point, a minimum for detonation and a maximum for deflagration. Here the Hugoniot curve is tangent to the product isentrope (the P vs V curve at constant entropy) passing thru the CJ point, and both are tangent to the Rayleigh line passing this point. This is shown in Curve B of Fig 1 (taken from Ref 18)

The various detonations and deflagrations and Rayleigh lines referred to in this Fig are depicted graphically on the Hugoniot curve in Fig 2 (also taken from Ref 18). When the finite thickness of the reaction is taken into account it is found that only strong or CJ detonations, and weak or CJ deflagrations exist in the real world

Referring to curve (B) of Fig 1, note that the isentrope thru the CJ point always lies between the Hugoniot and the Rayleigh line tangent to the Hugoniot at the CJ point

As a direct consequence of the nature of the variation of entropy along the Hugoniot curve, certain qualitative statements can be made as to the nature of the flows associated with states represented by points on the various sections of the Hugoniot. These statements have been called *Jouguet's rule*. The flow of the reaction products relative to the reaction front is subsonic behind a strong detonation or weak deflagration, sonic behind a Chapman-Jouguet detonation or deflagration, and supersonic behind a weak detonation or strong deflagration. If we refer to Fig 2, these statements can be expressed as:

$$\begin{aligned} |w_1| &< c_1 \text{ on AB and DE} & (21a) \\ |w_1| &= c_1 \text{ at B and E} \\ |w_1| &> c_1 \text{ on BC and EF} \end{aligned}$$

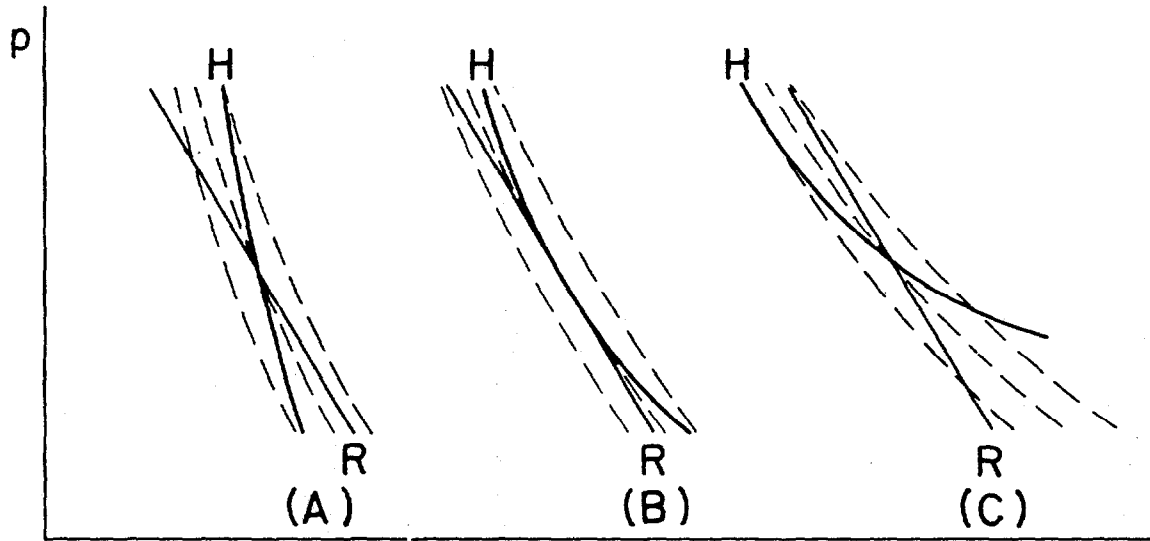

Fig 1 Hugoniot Curve (H), Rayleigh Line (R), and Isentropes (dashed curves) for (A) Strong Detonations and Weak Deflagrations, (B) Chapman-Jouguet Detonation and Deflagration, and (C) Weak Detonations and Strong Deflagrations

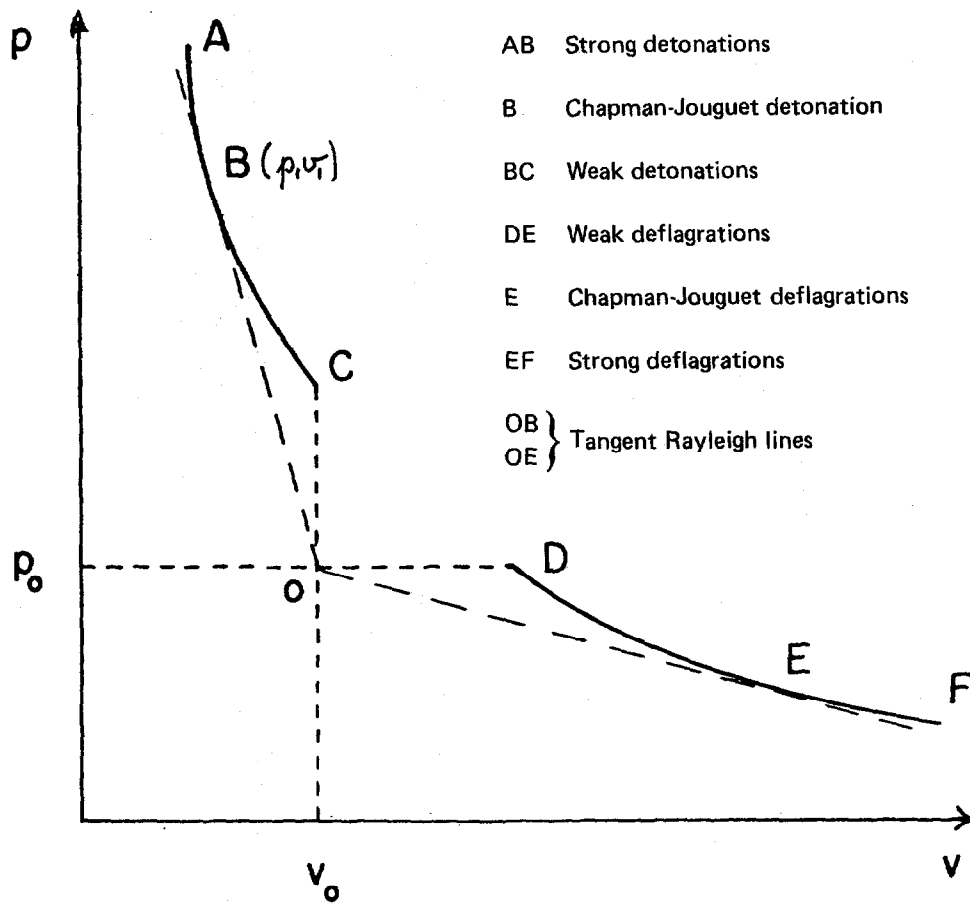

Fig 2 Nomenclature on the Hugoniot Curve for Detonation and Deflagrations

were c_1 is the velocity of sound at the point (p_1, v_1) and $w_1 = u_1 - D$. It can also be shown that the flow of the intact material relative to the reaction front is supersonic ahead of a detonation wave and subsonic ahead of a deflagration wave. Again according to Fig 2, these statements can be expressed by the relations:

$$D > c_0 \text{ on ABC} \quad (21b)$$

$$D < c_0 \text{ on DEF}$$

where c_0 is the speed of sound in the unreacted material at pressure p_0 and specific volume v_0

The Plane Detonation Wave with Finite Reaction Zone

The development of the thermo-hydrodynamic theory of detonation and its relation to the chemical processes that support detonation was achieved independently by Zeldovitch (Ref 7), vonNeumann (Ref 8) & Doering (Ref 9). For an *ideal gas* the fundamental equations of this theory are:

$$v_1 \approx \frac{\gamma_1 v_0}{\gamma_1 + 1} \quad (22a)$$

$$p_1 \approx \frac{2Q_1(\gamma_1 - 1)}{v_0} \quad (22b)$$

$$T_1 \approx \frac{2Q_1\gamma_1}{(\gamma_1 + 1)c_1} \quad (22c)$$

$$u_1 \approx \sqrt{\left\{ 2Q_1 \frac{\gamma_1 - 1}{\gamma_1 + 1} \right\}} \quad (22d)$$

$$D \approx \sqrt{\{2Q_1(\gamma_1^2 - 1)\}} \quad (22e)$$

$$D = \frac{\gamma_1 + 1}{\gamma_1} \sqrt{(\gamma_1 n_1 RT_1)} \quad (22f)$$

where Q is the heat of detonation (see Vol 7, H39-L to H43) and the subscript *one* designates the CJ state. Note that most of the terms in these equations are thermodynamic quantities. The only approximation in these equations is that p_0 can be neglected in comparison to p_1

An expln that occurs at constant volume is of considerable practical interest (eg, in commercial blasting). For an ideal gas, the relations between CJ and constant volume pressure and temp are:

$$\frac{p_1}{p_v} \approx 2 \quad (23a)$$

$$\text{and} \quad \frac{T_1}{T_v} \approx \frac{2\gamma_1}{\gamma_1 + 1} \quad (23b)$$

Here it was assumed that $\gamma_1 = \gamma_v$ and $n_1 = n_v$

All of the above equations, except the equations that contain T_1 , hold for detonation or expln of condensed expls if the products of these detonations or explns obey the polytropic EOS, and provided that γ is replaced by the polytropic coefficient κ

It was mentioned above that the only approximation in the above eqns for ideal gas detonation is the neglect of p_0 in comparison to p_1 . Unfortunately, this is not always completely justified because p_0 can be of the order of $0.1p_1$. It is simple enough to derive equations in which p_0 is included. Since the writer has never seen a correct set of such equations in the literature, the equations he derived (unpublished results) are given below:

$$\frac{v_0}{v_1} = \left(\frac{\gamma + 1 - (p_0/p_1)}{\gamma} \right) \quad (24a)$$

$$D = \frac{\gamma + 1 - p_0/p_1}{\sqrt{\gamma}} \sqrt{n_1 RT_1} \quad (24b)$$

$$p_1 = \frac{\rho_0 D^2}{\gamma + 1 - p_0/p_1} \quad (24c)$$

where $\rho_0 = 1/v_0$

$$T_v = \frac{\gamma + 1}{2\gamma} [1 - (p_0/p_1)^2] T_1 \quad (24d)$$

$$p_1/p_v = 2 / [1 - (p_0/p_1)^2] \quad (24e)$$

Another set of useful thermodynamic relations is:

$$e = pv/(\gamma - 1) \text{ for an ideal gas} \quad (25a)$$

$$e = pv/(\kappa - 1) \text{ for a polytropic gas} \quad (25b);$$

here e is the specific internal energy

Equations of State

Consider the conservation equations across a shock front (Eqns 19 & 20). There are four unknowns, u, U, v & e , but only 3 equations relating them. Thus another equation is required to determine completely the shocked state. This missing equation is an EOS. Any EOS is basically a thermodynamic relationship, although microscopic considerations may be used to evaluate deviations from ideal gas behavior. The most generally applicable EOS is one that relates

PV & T. An EPV EOS is also useful, but not as generally applicable as the PVT EOS

For a perfect gas the PVT EOS is the familiar ideal gas law. The equations grouped in 22, 23 & 24 follow directly from equations 19 & 20 and the ideal gas law. An EPV EOS follows directly from the assumption of a polytropic gas for the products of detonation. As already noted, this does not provide as complete a description of the detonation state as the PVT EOS (no information on T_1 and consequently on product compn)

Many attempts have been made to develop PVT relations for detonation products of condensed expls. These product gases, even in the absence of any condensed phase products, are very far from ideal. Thus most EOS for detonation products have included correction factors to account for non-ideality. Most product EOS are semi-empirical because they have to be adjusted to fit exptl data. Usually the Abel equation, $pv = nRT + \alpha p$, is used as a starting point. In the original Abel equation α is a constant co-volume, but a constant α does not agree with observation. Therefore various attempts have been made to modify the Abel equation by inclusion of $\alpha = \alpha(v)$ or $\alpha = \alpha(p)$ and so on. The various attempts at obtaining a "true" EOS are summarized in Vol 4, D268-L to D298-R. Below we will briefly describe a new EOS which was developed recently

A PVT EOS for a single species, based on concepts of molecular interactions, rather than semi-empirical modifications of the Abel EOS, was developed by Jacobs (Ref 17). It was then broadened to obtain relationships for detonation products by inclusion of mixt rules for n moles of s species. The most recent modification is called the JCZ-3 EOS (Jacobs-Cowperthwaite-Zwisler). For a general summary of JCZ-3 we quote from Ref 19:

"The equations of state developed by Dr. Jacobs are based on a (p-v-T) relationship for one mole of gas of the form

$$p = p_0(v) + G(v, T) RT/v$$

where $p_0(v)$ denotes the lattice pressure along the zero degree isotherm, R is the universal gas constant, and the G factor accounts for the thermal contribution to the pressure arising from intermolecular forces. For the purpose of this report, the problem of formulating the (p-v-T) equation for a single species can be considered

as that of constructing expressions for $p_0(v)$ and $G(v, T)$ with the pair potential describing the forces of interaction between the molecules. Since the Eq must describe states ranging from the ideal gas to the dense compressed state, the G factor must reduce to the virial expansion at low density and must approach the value determined by the repulsive potential at the high density limit. Dr. Jacobs took a semiempirical approach to this problem and used the results of Monte Carlo (MC) and Lennard-Jones & Devonshire (LJD) calculations to determine unknown parameters in theoretical expressions for $p_0(v)$ and $G(v, T)$."

For details of the evaluation of the terms of the above equation and the formulation of the mixing rules, the reader is referred to Refs 17 & 19

Application of Thermodynamics to Detonation Phenomena

In the previous sections we have seen how detonation theory is heavily dependent on the concepts of *thermodynamics*. Thermodynamics has been used to characterize various detonation phenomena thruout this Encycl. For example, *heat effects*, Vol 7, H38-L to H45; *EOS*, Vol 4, D268-L to D298-R; *products of detonation*, Vol 8, P387-L to P391-R; *pressure, detonation*, Vol 8, P367-L to P370-L; and *power of explosives*, Vol 8, P364-L to P366-R. Additional illustrative examples of the application of thermodynamics are presented below:

1) Detonation state of a CH_4 /air mixture

This example is presented because it illustrates most of the thermodynamic methods without the necessity of taking into account the complications arising from gas imperfection of the detonation products

Let us consider the detonation of the following methane-air mixt, initially at 1 atm and 298°K:

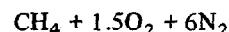

We have assumed that air is 20 mole % O_2 . The molecular weight, MW, of this mixt is 232.1, and its density, ρ_0 , at 1 atm and 298°K is 1.36g/l, assuming that the mixt is a perfect gas.

Provisionally, assume that the detonation reaction is:

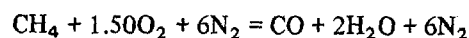

Table 1
Ideal Gas Free Energy Functions ($G^\circ/(RT)$) for Detonation Products

T, °K	CO ₂	CO	H ₂ O	H ₂	C(s)	NH ₃	N ₂	CH ₄	H	O
1000	-75.69	-38.88	-53.94	-17.49	-1.522	-31.70	-24.95	-34.17	-	-
1400	-63.66	-36.03	-46.77	-18.39	-2.064	-31.44	-25.97	-33.38	-	-
1500	-61.74	-35.61	-45.66	-18.59	-2.190	-31.49	-26.20	-33.38	-	-
1600	-60.09	-35.26	-44.70	-18.78	-2.312	-31.57	-26.43	-33.41	+0.435	-2.84
1800	-57.42	-34.72	-43.17	-19.14	-2.454	-31.79	-26.84	-33.59	-	-
2000	-55.36	-34.34	-42.00	-19.47	-2.764	-32.06	-27.24	-33.85	-3.31	-7.06
2500	-51.89	-33.79	-40.11	-20.20	-3.256	-32.83	-28.12	-34.70	-	-
3000	-49.83	-33.58	-39.07	-20.84	-3.686	-33.65	-28.89	-35.67	-	-
4000	-47.70	-33.58	-38.19	-21.90	-4.406	-35.24	-30.19	-37.61	-11.41	-16.11
5000	-46.81	-33.81	-37.99	-22.77	-4.996	-36.67	-31.29	-39.41	-13.24	-18.13

For this reaction the heat of reaction in the standard state is:

$$\Delta H_{298}^\circ = -124.1 \text{Kcal/mole CH}_4^*$$

From tables of average ideal molal heat capacities (eg, Table ii.4 in Ref 15)

$$\sum n_i(\bar{c}_v)_i = 60.0 \text{cal/mole-deg.}$$

Consequently,

$$\Delta H^\circ / \sum n_i(\bar{c}_v)_i = T_v - T_0 = 2068^\circ\text{K and}$$

$$T_v = 2068 + 298 = 2366$$

Since we expect (in view of Eq 23b) T_1 to be about 10% greater than T_v , let us provisionally take $T_1 = 2500^\circ\text{K}$. Now we expect the water gas equilibrium to determine the real compn of the detonation products. This equilibrium is:

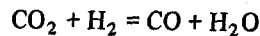

From tables of the ideal gas free energy function, Table 1, we get $\Delta G^\circ/RT = \sum (G^\circ/RT)_{\text{products}} - \sum (G^\circ/RT)_{\text{reactants}} = -1.81$, for the above reaction at 2500°K . According to equation 18:

$$\ln K_f = -\Delta G^\circ/RT = 1.81 \text{ or } \ln K_f = 6.11$$

Now let X be the number of moles of CO_2 at equilibrium, and $C, H,$ and O the original gram atoms of carbon, hydrogen and oxygen respec-

* Incidentally, by commonly accepted convention a negative ΔH° signifies an exothermic reaction. Similarly, a negative ΔG° means that from a thermodynamic point of view the reaction should be feasible. However, a negative ΔG° does not imply that the reaction will proceed rapidly

tively. Then from mass balance and Raoult's law:

$$p_{\text{CO}} = \frac{P(C-X)}{n_t}$$

$$p_{\text{CO}_2} = \frac{PX}{n_t}$$

$$p_{\text{H}_2\text{O}} = \frac{P}{n_t}(O-C-X)$$

$$p_{\text{H}_2} = \frac{P}{n_t}(\frac{1}{2}H+C-O+X)$$

where:

n_t = total number of moles of gas at equilibrium

p = partial pressure

P = total pressure at equilibrium

The ideal equilibrium constant for the water gas reaction is:

$$K_p = \frac{p_{\text{CO}} p_{\text{H}_2\text{O}}}{p_{\text{CO}_2} p_{\text{H}_2}} = \frac{(C-X)(O-C-X)}{X(\frac{1}{2}H+C-O+X)}$$

For an ideal gas $K_f = K_p$. Then for the above reaction:

$$K_p = 6.11 = \frac{(1-X)(3-1-X)}{X(2+1-3+X)}$$

and the solution is $X = 0.4$. Thus the detonation reaction is:

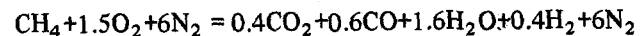

For this reaction $\Delta H_{298}^\circ = -128.1 \text{Kcal/mole CH}_4$; $\sum n_i(\bar{c}_v)_i = 60.9 \text{cal/}^\circ$ at $T_1 = 2500$, and $T_v - T_0 = 2103^\circ\text{K}$ or $T_v = 2401^\circ\text{K}$. For an ideal gas:

$$\sum n_i(\bar{c}_v)_i = R \sum n_i / \gamma - 1$$

which for the above gives $\gamma-1 = 0.29$ or $\gamma = 1.29$. Then from equation 23b:

$$T_1 = \frac{2(1.29)}{1+1.29} (T_v) = 2705^\circ\text{K}$$

Thus our guess of $T_1 = 2500^\circ\text{K}$ was a little low. We repeat all of the above steps with $T_1 = 2750^\circ\text{K}$ and obtain:

$$\begin{aligned} \Delta G^\circ/RT &= -1.90 \\ K_f &= 6.69 \\ X &= 0.38 \\ \text{CH}_4 + 1.5\text{O}_2 + 6\text{N}_2 &= 0.38\text{CO}_2 + 0.62\text{CO} + \\ &\quad 1.62\text{H}_2\text{O} + 0.38\text{H}_2 + 6\text{N}_2 \\ \Delta H^\circ &= -127.9\text{Kcal/mole CH}_4 \\ \sum n_i(\bar{c}_v)_1 &= 61.7\text{cal/}^\circ \\ T_v &= 2371^\circ\text{K} \\ \gamma &= 1.29 \\ T_1 &= 2671^\circ\text{K} \end{aligned}$$

None of the above quantities will change appreciably upon further iteration. Thus we can safely use $T_1 = 2671^\circ\text{K}$ and $\gamma = 1.29$ for the computation of other detonation parameters. Now, on a per gram basis:

$$Q_1 = -\Delta H^\circ/MW_{\text{mixt}} = 0.551\text{Kcal/g} = 2.303 \times 10^{10} \text{ ergs/g}$$

and

$$n_1 = \sum n_i/MW_{\text{mixt}} = 0.388 \text{ moles/g.}$$

Then from equation 22:

$p_1 \approx 2Q_1(\gamma-1)\rho_0 \approx 18.2$ bars, but $p_0 = 1.013$ bars, thus neglect of p_0 is likely to introduce a small error

Consequently we turn to equation 24d to recompute T_1 , provisionally taking $p_1 = 18.2$ bars. The corrected $T_1 = 2680^\circ\text{K}$ or very close to the 2671°K obtained above. Then from equation 24b, using $T_1 = 2680$,

$$D = 1870 \text{ m/sec,}$$

and from Eq 24c:

$$p_1 = 20.8 \text{ bars,}$$

and from Eq 24a:

$$v_1 = 0.565v_0.$$

Since, $u_1/D = 1 - v_1/v_0 = 0.435$

Thermodynamics can also be used to exclude reactions which, at least at first glance, appear to be feasible. In the above example, since there are appreciable amounts of N_2 and H_2 present, one might ask whether NH_3 is formed via:

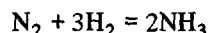

From the table of free energy functions, ΔG°

for this reaction is $+127\text{Kcal/mole}$. Thus, ammonia formation is most unlikely

Heat of Detonation

This subject was examined in Vol 7, H38-L to H39-L, where we pointed out the seemingly fortuitous agreement between calorimetrically measured heats of detonation and heats of detonation computed for the CJ state by the BKW EOS. The former values are for $(\text{H}_2\text{O})_{\text{liq}}$ while the latter are for $(\text{H}_2\text{O})_{\text{gas}}$. Furthermore, the CJ compns contain considerably more CO_2 than the expanded detonation products of the calorimetric measurements. As suggested in the Vol 7 article, it appears that several compensating effects are operative, but it is strange that for many expls these compensating effects are so closely balanced. On the basis of thermodynamic considerations, we might expect that the main compensating effects are the decrease in CO_2 as detonation products re-equilibrate during expansion vs the heat of vaporization of water (recall that for CJ state calcns H_2O is considered to be a gas, while in the calorimeter H_2O is liq). Support for this expectation is provided in Table 2 with entries in the Table taken from Ref 20. It is known that large CJ pressures (P_j) favor CO_2 production at the expense of CO , namely:

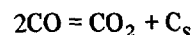

Obviously if detonation products contain little H_2O , the compensating action of H_2O heat of vaporization will be small. The water gas equilibrium favors CO_2 and H_2 as the temp drops during product expansion, but the heat effect of this equilibrium shift is fairly small. Thus one might expect that computed and measured heats of detonation (Q) should be nearly equal for expls whose products contain appreciable H_2O at large values of P_j .

This is indeed the case for the expls listed in Table 2. Detonation pressures in the top grouping are all in excess of 300kb and the products in this grouping all contain more than one mole of H_2O per 100g of expl. In this grouping exptl and computed heats of detonation match almost exactly

In the lower grouping of Table 2, exptl heats of detonation are found to be progressively less than computed heats of detonation as one proceeds down the table. Two different effects

Table 2
Possible Rationale for the Near-Equivalence of Calorimetric
and Computed Heats of Detonation

High Explosive (a)	Q (Kcal/g)		H ₂ O	P _j (kbar)
	Exptl (H ₂ O) _g	Calcd (H ₂ O) _g	(moles/100g HE) (b)	
PETN	1.49	1.51	1.27	330
HMX	1.48	1.48	1.33	395
RDX	1.51	1.48	1.35	~350
PBX 9404	1.38	1.41	1.33	375
LX-04	1.31	1.31	1.05	350
Nitromethane	1.23	1.33	2.46	130
LX-11	1.16	1.28	0.95	310 (c)
DATB	0.98	1.15	1.10	259
Comp B	1.20(?)	1.40	1.33	295
Tetryl	1.25	1.44	0.87	283
TNT	1.09	1.27	1.10	190
Tacot	0.98	1.35	0.52	181 (c)
Benzotrifuroxan (BTF)	1.41	1.69	0.00	~360

- (a) All expls are close to their max density
(b) Computed for the CJ state via BKW EOS
(c) Calcd; all others are exptl values

appear to be operative. For example, Nitromethane products contain large amounts of water but P_j is low, whereas Tetryl products contain much less water but P_j is fairly large. Tacot products contain little water at a fairly low P_j and its exptl Q is appreciably lower than the computed Q for the CJ state

Now let us consider Benzotrifuroxan (BTF), the last entry in Table 2. It produces no water and its P_j is large. Since no water is produced, the above compensating effects are inoperative. We may speculate that the computed Q is larger than the measured Q because the reaction $2\text{CO} = \text{CO}_2 + \text{C}_{(s)}$ proceeds to the left, because some product expansion is unavoidable in the calorimeter. This reaction (CO formation) is endothermic. If the above suppositions are correct, one would expect closer agreement between computed and measured Q's for BTF at low packing densities (at low P_j little CO₂ is formed via the above reaction and obviously it cannot subsequently revert to CO upon product expansion)

Use of the Polytopic EOS

In a preceding section we have already remarked about the usefulness of the polytopic EOS. Here we wish to consider several approximate but nevertheless valuable deductions made on the basis of this EOS. From equations 19a and 19b with the shock velocity U replaced by the detonation velocity D:

$$(D-u_1)^2 = D^2(1-\rho_0/\rho_1) = D^2(\rho_0/\rho_1)^2$$

$$\text{and } p_1 = \rho_0 D^2(1-\rho_0/\rho_1) \text{ if } p_1 \gg p_2.$$

Then from the CJ condition and equation 12:

$$(D-u_1)^2 = c^2 = \kappa p_1/\rho_1 = \kappa \rho_0 D^2(1-\rho_0/\rho_1)/\rho_1 = D^2(\rho_0/\rho_1)^2.$$

Solving for ρ_0/ρ_1 gives:

$$\rho_0/\rho_1 = \kappa/(\kappa+1) = v_1/v_0 \quad (26)$$

and its substitution in the equation for p₁ gives:

$$p_1 = \rho_0 D^2/(\kappa+1) \quad (27)$$

For a constant volume expln, $e(p_v v_0) = e_0$.

Then from equations 19c and 25b, assuming that detonation products are polytropic between the states $(p_1 v_1)$ and $p_v v_o$:

$$e_1 - e_o = e_1 - e_v = \left[\frac{1}{\kappa - 1} \right] (p_1 v_1 - p_v v_o) = \frac{1}{2}(p_1 + p_o)(v_o - v_1).$$

After eliminating v_1 according to equation 26 and neglecting p_o in comparison with p_1 , we obtain:

$$\left[\frac{1}{(\kappa - 1)} \right] \left[p_1 \kappa / (\kappa + 1) - p_v \right] = (p_1 / 2) \left[1 - \kappa / (\kappa + 1) \right]$$

On simplifying we obtain:

$$p_1 / p_v = 2 \tag{28}$$

in agreement with equation 23a for an ideal gas

That $p_1 / p_v \approx 2$ is obtained a posteriori from other EOS. For example, the calcns with the JCZ-3 EOS (Ref 19) give $2.12 \leq p_1 / p_v \leq 2.22$ for RDX and TNT over a range of ρ_o from 1 to 1.8 g/cm^3

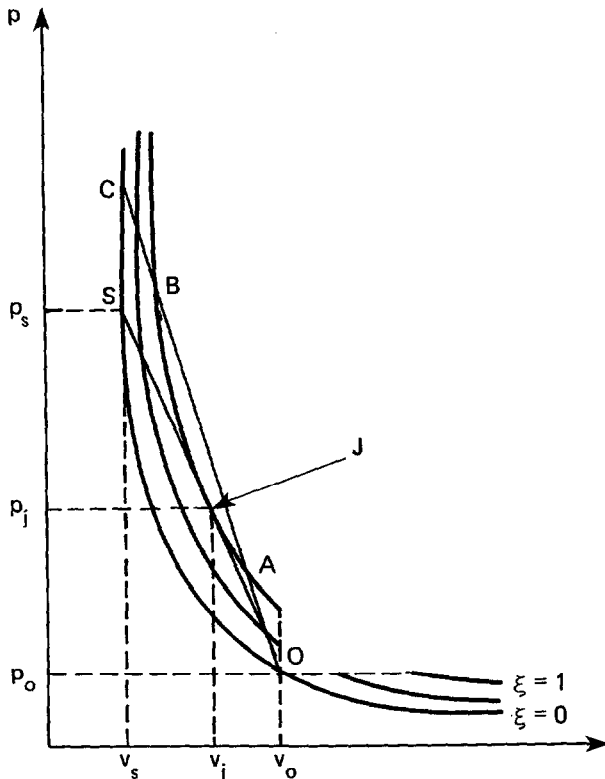

Fig 3 Family of Hugoniot Curves for Steady Detonation Wave

We will need some background before we describe a further application of the polytropic EOS, namely estimation of the magnitude of the "spike" pressure. The VonNeumann-Zeldovitch-Doering model of detonation can be summarized graphically as shown in Fig 3 (sketch taken from Ref 18):

The Hugoniot for detonation products (complete reaction) is labelled $\xi = 1$, and the one for unreacted expl is labelled $\xi = 0$. The subscripts o, j and s designate the original, CJ and "spike" states respectively. The line OJS is the Rayleigh line that we wish to consider. From the conservation laws, the slope of this line for any arbitrary p and v is:

$$\rho_o^2 D^2 = -(p - p_o) / (v - v_o)$$

or, neglecting p_o :

$$p_s / (v_o - v_s) = p_j / (v_o - v_j), \text{ and}$$

$p_s / p_j = (v_o - v_s) / (v_o - v_j) = (1 - v_s / v_o) / (1 - v_j / v_o)$, but from equation 26, the denominator of the right-hand term is $1 / (\kappa + 1)$, therefore:

$$p_s / p_j = (\kappa + 1) (1 - v_s / v_o)$$

This equation gives an upper limit for p_s / p_j , namely $(\kappa + 1)$ if $v_s / v_o \ll 1$. An extreme lower limit can be obtained by assuming that $v_s = v_j$, whereas in reality $v_s < v_j$. With this drastic assumption:

$$p_s / p_j = (\kappa + 1) (\kappa + 1) = 1. \text{ Thus, } 1 < p_s / p_j < \kappa + 1 \text{ or } 1 < p_s / p_j < 4 \text{ if } \kappa = 3$$

Written by J. ROTH

Refs: 1) J.W. Gibbs, TransConnecticut AcadSci 3, 228 (1876) 2) H.L. LeChatelier, AnnMines 13, 157 (1888) 3) F. Haber, "Thermodynamik der Technischen Gas Reaktionen"(1905) 4) J.W. Gibbs, "The Scientific Papers of J. Williard Gibbs" (1906), & Ibid, "Thermodynamics", Vol 1, Dover Publications, NY (1961) 5) G.N. Lewis & M. Randall, "Thermodynamics and the Free Energy of Chemical Substances", McGraw-Hill, NY (1923) 6) R.L. Scorer, JChemPhys 3, 425 (1935) 7) Y.B. Zeldovitch, JhEkspitsorFiz 10, 542 (1940) 8) J. von-Neumann, OSRD 549 (1942) 9) W. Doering, AnnPhysik 43, 421 (1943) 10) S.R. Brinkley & J.G. Kirkwood, "3rd Symp Combustn & Flame & Expln Phenomena", Williams & Wilkins, Baltimore (1949), 586 11) J. Taylor, "De-

tonation in Condensed Explosives", Clarendon Press, Oxford (1952) 12) I. Prigogine & R. Defoy, "Chemical Thermodynamics", Longmans, Green, NY (1954) 13) W.W. Wood & J.G. Kirkwood, JChemPhys **25**, 1276 (1956); Ibid **29**, 957 (1958) 14) E.A. Guggenheim, "Thermodynamics; An Advanced Treatment for Chemists and Physicists", 3rd Ed, Interscience Publishers, NY (1957) 15) M.A. Cook, "The Science of High Explosives", VanNostrand Reinhold, NY (1958) 16) K. Pitzer & L. Brewer, "Thermodynamics", McGraw-Hill, NY (1961) 17) S.J. Jacobs, 12th Combustn Symp (Intern), The Combustion Institute, Pittsburgh (1969), 501 18) Anon, EngrgDesHndbk, "Principles of Explosive Behavior", **AMCP 706-180** (1972) 19) M. Cowperthwaite & W.H. Zwisler, Stanford Res Inst Final Rept, Contr N60921-72-C-0013 (1973) 20) B.M. Dobratz, "Properties of Chemical Explosives and Explosive Simulants", **UCRL-51319**, Rev 1, Lawrence Livermore Lab, Univ of Calif (1974)

Thermogravimetry. See under "The Thermochemistry of Energetic Materials" in this Vol

Thermohydrodynamic Theory of Detonation. See under "Hydrodynamic and Hydrothermodynamic Theories of Detonation" in Vol 4, D610-L to D619-L

Thermometers, Calibration of TNT. See in Vol 2, C6-R to C8-L

Thianthrenium Perchlorate.

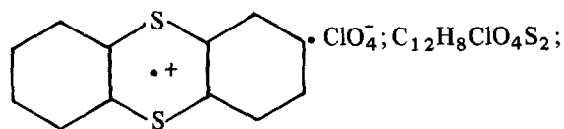

mw 315.79; OB to CO₂ & SO -136.8%; dk, reddish-brn crystals; mp, decomps on heating without melting. CA Registry No [21299-20-7]. Prepn is by addn of a soln of 0.5g of thianthrene in 100ml of carbon tetrachloride to a soln of 0.8ml of 70% perchloric acid in 50ml of Ac₂O. The soln is then allowed to stand overnight, the ppt filtered and carefully dried. *Caution!* The dry salt is v friction sensitive and can expld violently when rubbed or handled

Refs: 1) Beil, not found 2) Y. Murata & H.L. Shine, JOC **34**, 3372 (1969)

Thiazole and Derivatives

Thiazole. C₃H₃NS; mw 85.13; N 16.46%; colorl liq, foul odor resembling pyridine, bp 115-18°; d 1.20g/cc at 17°. Sol in many org solvents such as ethanol and eth; sl sol in w. CA Registry No [288-47-1]. Prepn and properties in Beil **27**, 15, (207) & [9]. Several of its nitrated expl derivs are presented below:

4-Methyl-2-Nitramino-3,5-Dinitrothiazole.

C₄H₃N₅SO₆; mw 249.18; N 28.11; OB to CO₂ -22.47%; white cryst; mp 98° (explds). It is decompd by solvents such as benz, eth acetate and acetic acid. Prepn is by careful nitration of 4-methyl-2-nitramino-5-nitrothiazole with nitric acid-acetic anhydride mixt (30/70) at 5°

2-Nitramino-5-Nitrothiazole. C₃H₂N₄SO₄; mw 190.15; N 29.47%; OB to CO₂ -25.24%; cryst; mp 162° (explds). Prepn is by nitration of a soln of 2-aminothiazole (10g) in 7ml of concd sulfuric acid with mixed acid (2 vols of 90-95% nitric acid to 1 vol of concd sulfuric acid) at 0-5°

Refs: 1) Beil **27**, 15, [9 & 207] 2) H.v. Bobo & B. Prijs, Helv **33**, 306-13 (1950) & CA **44**, 5872 (1950) 3) S. Vicon & A. Taurius, CanJ-Chem **31**, 885-93 (1950) & CA **44**, 5872 (1950)

2-Thiazolinimine, 3,4-Dinitro. C₃H₂N₄O₄S; mw 190.15; N 29.47%; OB to CO₂ -25.24%; yel ndls; mp 172° (expld). Sol in hot w. Prepn is by hydrolysis of 2-acetamido-5-bromo-3,4-dinitro-2-hydroxy-Δ⁴-Thiazole with boiling w (refluxing until complete soln), filtering hot and then allowing to cool

Refs: 1) Beil, not found 2) S.J. Viron & A. Taurius, CanJChem **31**, 888 (1950) & CA **44**, 5872 (1950)

Thickeners. See in Vol 8, M1-L under "M1, M2, M4 Thickeners" and N2-L to N3-R under "Napalm (Thickened Fuel)"

Thiocyanate, Lead. See in Vol 7, L11-L

Thiocyanic Acid Complexes of Cobalt Perchlorate.

Thiocyanatocobalt (III) pentammine Diperchlorate. NCSCo(NH₃)₅⁺.2ClO₄⁻; CH₁₅Cl₂CoN₆O₈S; mw 401.06; OB to CO₂, CoO & SO -9.97%; deep rose red ndls (Refs 1 & 3); CA Registry No [15002-11-6]. Prepd by the addn of the di-cyanate salt to an ice-cold soln of Na perchlorate, the ppt filtered, washed with cold w, and dried (Ref 3). Expln temp 325°; impact sensy with a 2kg wt, 55cm (TNT 95cm); and power by sand test: 20.1g of sand crushed (TNT 42.0g) (Ref 2)

Dithiocyanatocobalt (III) tetra-amine Perchlorate. (NCS)₂Co(NH₂)₄⁺.ClO₄⁻; C₂H₁₂ClCoN₆O₄S₂; mw 342.66; OB to CO₂, CoO, & SO -16.3%; a cryst solid; expln temp 335°; impact sensy under

the same conditions as above, 35cm (LA 10cm); power by sand test: 13.9g of sand crushed (MF 21g)

Refs: 1) Gmelin, System No 58, Suppl Part B-2 (1964), 450 2) W.R. Tomlinson et al, JACS 71, 376 (1949) 3) R.L. Carlin & J.O. Edwards, JInorgNuclChem 6, 217 (1958) & CA 52, 18054 (1958)

4-Thiocyanophenylnitramine, 3,6-Dinitro-

$C_7H_5N_5SO_6$; mw 287.23; N 24.39%; OB to CO_2 -47.35%; an unstable solid which, within 4 wks of storage after prepn, turns into a v viscous liq; mp, expl decompn at 70° . Prepn is by the nitration of 4-thiocyanoacetanilide with abs nitric acid at -10°

Refs: 1) Beil, not found 2) J.W. Dienske, Rec 50, 165-83 (1931) & CA 25, 2699 (1951)

X-Dinitraminodiazole. $C_2H_2N_6SO_4$; mw 206.16; N 40.77%; OB to CO_2 -7.76%; OB to SO_2 -23.2%; brn cryst; mp, deton violently when heated. Prepn is by the nitration of diamino-1,3,5-thiadiazole with a mixt of white nitric acid and acetic anhydride at -10° , and then quenching in eth. The compd has a deton vol of 761ml/g and a Q_e of 1152cal/g

Refs: 1) Beil, not found 2) H.P. Burchfield et al, "Research and Development . . . New High Explosives . . . from Compounds of Nitrogen and Sulfur . . .", NORD 10121 (3), US Rubber Co, Naugatuck (1949), 22-23

Thional. See in Vol 5, D1480-L, under "2,4,2',4',6-Pentanitrodiphenyl-Sulfone . . ."

Thiophene and Nitrated Derivatives

Thiophene (Thiofuran, Thiofurfuran, Thiole, Thiotetrole or Divinylene sulfide). C_4H_4S ; mw 84.14; liq, sl aromatic odor resembling that of benz; mp -38.3° ; bp 84.4° ; d 1.0285g/cc at $50/4^\circ$; RI 1.52684. Insol in w; miscible with most org solvents. CA Registry No [110-02-1]. Found in coal tar, in coal gas and in tech benz. Comml prepn is by the dehydrogenation of bu-

tane using S, followed by cyclization with S to form the thiophene ring

This heterocyclic structure is an unusual molecule, having an interesting mixt of aromatic-aliphatic properties. It is considered as an explosophoric of possible great use, however with less power than tetrazole. A representative group of the expl derivatives of thiophene are presented below

Refs: 1) Beil 17, 34-38, (17) & [35-38] 2) Merck (1976), 1207 (No 9090)

2,5-Dibromo-3,4-Dinitro-Thiophene.

$C_4N_2Br_2SO_4$; mw 331.93; N 8.44%; OB to CO_2 -19.28%; yel cryst (from ethanol); mp 134° , $139-40^\circ$ (separate values). Sl sol in ethanol. Preparation is by the action of nitric acid on a mixt of 1 vol of 2,5-dibromothiophene and 5 vols of concd sulfuric acid. Ref 2 considers this compd as an expl

Refs: 1) Beil 17, 36 2) ADL Punch Cards (1961), card set 30.02

2,4-Dinitro Thiophene (DNTh). $C_4H_2N_2SO_4$; mw 174.14; N 16.09%; OB to CO_2 -45.94%; leaflets (from ethanol); mp 49.0° , 50.0° , 56.0° (separate values). Sol in ethanol. Prepn is by reacting /3-nitro thiophene with fuming nitric acid at $35-40^\circ$, and then warming to $50-60^\circ$

DNTh has a Q_e^p of 580.2kcal/mole. Mixts of DNTh with TeNMe (51.6/48.4%) have given values of 120% RDX or 245% TNT in the Trauzl Pb block test

Refs: 1) Beil 17, 35 & [37] 2) ADL Punch Cards (1952), 555 3) Ibid (1961), Card set 01.11, 30.02 & 52.01

2,5-Dinitro Thiophene. $C_4H_2N_2SO_4$; mw 174.14; N 16.09%; OB to CO_2 -45.94%; monoclinic prisms; the compd exists in two forms differentiated by mp: *Form 1* - mp 52° ; yel ndls (from ethanol); bp 290° . Slowly sol in hot w. Prepn is by the action of fuming nitric acid on 2-nitrothiophene. *Form 2* - mp 78° , $80-82^\circ$ (separate values); bright yel ndls (from ethanol or w). Prepn is by steam distln of the 52° mp form

The 52° mp form has been evaluated as an expl and reported on by Sager and Sickman (Ref

2). They state that its impact sensy is above 160cm using an ERL machine with a 2.5kg wt, and that the vac stab test at 120° produces no gas

Refs: 1) Beil 17, 35-36 & [38] 2) W.F. Sager & D.V. Sickman, "Second Report on Research and Development in New Chemical High Explosives", NAVORD 483 (1952), 29

3-Methyl-2,4-Dinitrothiophene. $C_5H_4N_2SO_4$; mw 188.16; N 14.89%; OB to CO_2 -68.03%; cryst; mp 86-89°. Prepn is by nitration of 3-methyl-thiophene. The compd has a Q_C^p of 738.2kcal/mole. *Refs* 2 & 3 term it an expl
Refs: 1) Beil, not found 2) ADL Punch Cards (1952), 555 3) Ibid (1961), Card sets 01.11 & 30.02

Thiophenol and Derivatives. See in Vol 2, B60-R to B61-R, under "Benzenesulfenic Acid and Derivatives". An addnl derivative is presented below:

Thiophenol, 2,4,6-Trinitro (2,4,6-Trinitrophenylmercaptan or Picrylmercaptan). $C_6H_3N_3SO_6$; mw 245.18; N 17.14%; OB to CO_2 -48.94%; v small yel ndls with a bitter taste; mp 114°; v sol in acet, benz, chl, ethanol and w; insol in carbon disulfide and petr eth. Prepn is by reacting an ethanolic soln of K_2S with an ethanolic soln of picryl chloride. The K salt formed is filtered off and dissolved in w and then hydrolyzed with hydrochloric acid to the free nitrate. The picryl compd explds with extreme violence at 115°. The salt, **Potassium-2,4,6-Trinitro-Thiophenol**; $KC_6H_2N_3SO_6$; mw 283.27; N 14.84%; OB to CO_2 -48.94%; reddish brn ndls; v sol in ethanol and w; difficultly sol in eth and w; mp, explds with great violence at 140°
Ref: Beil 6, 344 & [316]

Thiopicric Acid (2,4,6-Trinitrothiophenol, 2,4,6-Trinitrophenylmercaptan or Picryl mercaptan). $(O_2N)_3C_6H_2.SH$; mw 245.18; N 17.14%; OB to CO_2 -48.94%; small yel ndls; mp 114°. Sol in acet, benz, ethanol, eth and w; v sl sol in carbon

disulfide and petr eth. Prepn is by first obtaining the K salt of trinitrophenol and then hydrolyzing the salt with dil mineral acid. The K salt is prepd by reacting an ethanolic soln of K_2S with an ethanolic soln of picryl chloride. Thiopicric Acid explds at 115°. It forms expl salts such as the K salt, **Potassium Thiopicric Acid**, $KC_6H_2N_3SO_6$; mw 283.27; red-brn ndls; mp, explds violently at 140°; v sol in ethanol and w; sl sol in eth

Refs: 1) Beil 6, 344 & [316] 2) C. Wilgerodt, Ber 17, 252 (1884) 3) V. Thomas et al, CR 178, 1289 (1924) & CA 18, 1995 (1924)

Thiosugars. Augstkalns and Miller report that the thiosugar polymer compns shown in Table 1 were polymerized as indicated in Table 2 evaluated as fuels and bonding agents in standard red smoke pyrot munitions (Table 3), and were found to have favorable combustion and sensy characteristics. The authors recommended that processing procedures be improved to minimize agent degradation during polymerization and storage at 160°F

Ref: V.A. Augstkalns & J. Miller, "Evaluation of Sugar-Based Syrups and Polymers as Fuels in Pyrotechnic Systems", EATM-241-B (1967)

5-Amino-1,2,3,4-Thiotriazole. CH_2N_4S ; mw 102.13; N 54.87%; ndls (from eth), columns (from methanol plus eth); mp, deton at 128-30°. Sol in aniline, warm ethanol, acetic acid, and acetic anhydr; sparingly sol in chl and carbon disulfide; insol in benz. Prepn is by reacting a cold Na nitrite soln with an aq soln of thiosemicarbazide hydrochloride. The hydrochloride of the thiotriazole is also an expl;
5-Amino-1,2,3,4-Thiotriazole Hydrochloride, CH_2N_4S+HCl ; mw 138.59; N 40.43%; cryst; mp, deton at 96°. V sol in w
Ref: Beil 27, 781

Thiotriithiazyl. The $(NS)_3S^-$ radical derived from Tetrasulfur Tetranitride (see in Vol 8, N102-L to N103-L, entered as "Sulfur Nitride"). Its monosubstituted expl derivatives are presented below:

Thiotriithiazyl Bromide (or Thionitrososul-

Table 1
Fuel Syrups Supplied by Resin Research Laboratories

Fuel syrup Designation	Fuel syrup synthesis
RR 110-3	Condensation – glucose, 1 mole, thiodiglycol, 2 moles, p-toluene sulfonic acid, 0.5% by weight, for 60 mins at $130 \pm 5^\circ\text{C}$ under $25 \pm 5\text{mm}$ of pressure
RR 214-6	Condensation – lactose, 0.2 mole, thiodiglycol, 1 mole, p-toluene sulfonic acid, 0.5% by weight, for 140 mins
RR 222-2	Condensation – lactose, 0.5 mole, thiodiglycol, 2.375 moles

Table 2
Cure Data on Fuel Syrup Polymers

Test No.	Fuel Syrup	Percent	Polymer Crosslinker	Percent	Catalyst	Cure Time
1	RR 110-3	65	Versamid 125	35	β -lactose sulfuric acid	Three days at 160°F Three hours at 220°F
2	RR 110-3	60	Vorite 145	40	Stannous octoate	One hour at ambient room temperature
3	RR 222-2	70	Vorite 145	30	Stannous octoate	One hour at ambient toom temperature

Table 3
Burning-Rate Tests of Pyrotechnic Mixtures Containing in Situ Polymerized Fuel Syrup^a

Test No.	Grain Density gm/cc	Burning Rate cm/cc	Slag %	Ignition Temperature $^\circ\text{C}$	Remarks
1	1.60	0.07	24	208	Excellent color
2	1.47	0.09	21	177	Good color; hot burning
3	1.45	0.12	20	184	Excellent color; hot burning

Footnote to Table 3:

a-the formulations contd 50% red dye, 30% K chlorate and 20% polymer

fonium bromide). $(\text{NS})_3\text{SBr}$; mw 250.17; N 16.80%; yel ndls; mp, explds on heating. Sol in concd mineral acids; sl sol in chl; insol in carbon tetrachloride, carbon disulfide, eth and gasoline. Prepn is by treating Tetrasulfur Tetranitride with hydrogen bromide in the presence of a trace of moisture

Refs: 1) W. Muthmann & E. Seitter, *Ber* **30**, 627 (1897) 2) H. Wölbling, *ZAnorgChem* **57**, 281–89 (1908) 3) Mellor **8** (1928), 632 4) A.G. MacDiarmid, *Nature* **164**, 1131–32 (1949) & *CA* **44**, 3391 (1950)

Thiotriethiazyl Chloride. $(\text{NS})_3\text{SCl}$; mw 205.72; N 20.43%; yel solid; mp, explds on heating. Sol in dil alkali acids such as sulfuric and nitric (with decompn) and w; sol in concd mineral acids (without decompn); sl sol in chl; insol in carbon tetrachloride, carbon disulfide, eth and gasoline; decompd by benz, gl acetic acid, acet and pyridine. Prepn is by treating a chl soln of Tetranitrogen Tetrasulfide with sulfur monochloride. The refs term the chloride as a shock sensitive expl

Refs: 1) E.A. Demarcay, *CR* **91**, 845, 1066 (1880) 2) *Ibid*, *Ber* **14**, 253 (1881) 3) A. Andreocci, *ZAnorgChem* **14**, 246–50 (1897) 4) W. Muthmann & E. Seitter, *Ber* **30**, 627 (1897) 5) H. Wölbling, *ZAnorgChem* **57**, 281–82 (1908) 6) Mellor **8** (1928), 631 7) A.G. MacDiarmid, *Nature* **164**, 1131–32 (1949) & *CA* **44**, 3391 (1950)

Thiotriethiazyl Iodide (or Thionitrososulfonium iodide). $(\text{NS})_3\text{SI}$; mw 297.16; N 14.14%; red solid. Soly is similar to the chloride shown above. Prepn is by treating Tetranitrogen Tetrasulfide with HI in the presence of a trace of moisture. The iodide is termed an expl by the refs

Refs: 1) W. Muthmann & E. Seitter, *Ber* **30**, 627 (1897) 2) Mellor **8** (1928), 632 3) A.G. MacDiarmid, *Nature* **164**, 1131–32 (1949) & *CA* **44**, 3391 (1950)

Thiotriethiazyl Nitrate (or Thionitrososulfonium nitrate). $(\text{NS})_3\text{S}\cdot\text{NO}_3$; mw 232.28; N 24.13%; long yel transparent prisms, becoming opaque on standing for several days after prepn. Sol in w with decompn as shown by the rapid change of the clear yel soln to opaque, and the pptn of a blk substance mixed with free S. Prepn is by dissolving Thiotriethiazyl Chloride in nitric acid and evapn of the solvent in vacuo. The refs

term the nitrate as a v violent expl

Refs: 1) W. Muthmann & E. Seitter, *Ber* **30**, 627 (1897) 2) Mellor **8** (1928), 631–32

Thiourea Nitrate. $\text{H}_2\text{NCNH}_2\cdot\text{HNO}_3$;

$\text{CH}_5\text{N}_3\text{SO}_3$; mw 139.15; N 30.20%; OB to CO_2 –17.25%; cryst; mp 130–34°. Prepn is by the action of dil nitric acid (d 1.33g/cc) on thiourea at 5–10°. The nitrate has an ign temp of 410° (in 0.5 sec) and a Trauzl Pb block expansion value of 150cc. It is considered to be a weak expl (Ref 3)

Refs: 1) Beil **3**, 185 & (75) 2) A.L.P. Coll, *Afinidad* **30**, 104–05 (1953) & *CA* **49**, 1565 (1955) 3) Urbański **2** (1965), 470

Thiourea Perchlorate. $\text{H}_2\text{NCNH}_2\cdot\text{HClO}_4$;

$\text{CH}_5\text{ClN}_2\text{O}_4\text{S}$; mw 176.58; N 13.60%; OB to CO_2 & SO –13.6%; hydr ndls; mp 106–07°, explds on further heating. *CA* Registry No [18720-57-5]

Refs: 1) Beil **3**, {298} 2) S. Micewicz, *PrzemyslChem* **10**, 56 (1926) & *CA* **25**, 3964 (1931)

1-Thioureido-3-Nitroguanidine (or Nitramidino-3-thio-semicarbazide). $\text{C}_2\text{H}_5\text{N}_6\text{SO}_3$; mw 194.20; N 43.29%; OB to CO_2 –32.96%; fine white powder; mp 182–83° (violent deton). Sol in w. Prepn is by refluxing 3,5-dimethyl-1-nitroguanilpyrazole with thiosemicarbazide in aq ethanol. A 70% yield is obtd after filtn, evapn of the filtrate followed by ethereal extn of the residue, leaving the w-sol guanidine product

Refs: 1) Beil, not found 2) F.L. Scott et al, *JACS* **75**, 1296–97 (1953) & *CA* **48**, 5182 (1954)

Thomas' Explosives. Under this title, Ref 1 states that Thomas of London patented (1897–98) a safety expl contg AN 87.5, DNN 10.0 and $\text{Na}_2\text{S}_2\text{O}_3$ 2.5%. Ref 2 refers to a 1905 patent covering the incorporation of chlorates or perchlorates in TNT based expl formulations
Refs: 1) Daniel (1902), 766 2) Giua, *Trattato* **6** (1959), 398

Thomas Fume Test (Dutch Test). See under "Fume Tests" in Vol 6, F236-R to F238-R, and under "Dutch Stability Test" in Vol 5, D1580-R

Thorite. An expl, patented in Fr by Bowden in 1895, which was prepd by blending powdered K chlorate with an aq sugar soln, followed by graining and drying. It was intended for both military and industrial use (Refs 4 & 6)

Van Gelder and Schlatter (Ref 5) state that a US version of Thorite contained AN mixed with nitro aromatic compds. Thorite was at first highly commended (Ref 1) but a later report criticized it adversely due to the failure to obtain a uniform degree of detonation or expln, "which appears to be inherent in this class of explosives" (Ref 2). More likely the defect lay in the strength of the fuze, AN expls requiring an exceptionally heavy detonator. In spite of the adverse opinion of the Bureau of Ordnance, the Congress appropriated funds for the purchase of Thorite (Ref 3), and shells filled with this material were used in the Philippine Islands during the Spanish-American War

Refs: 1) Anon, "Annual Report of the Chief of Ordnance, US Army" (1899), 22 2) Ibid (1900), 40 3) Ibid (1901), 16 4) Daniel (1902), 766 5) VanGelder & Schlatter (1927), 342 & 938-40 6) Giua, Trattato 6 (1959), 395

Thorium and Compounds

Thorium. Th; at w 232.0381; at no 90; valence 4; long-lived natural isotope: 232; other isotopes: 224-231, 233-235; greyish-white, lustrous, radioactive metal, somewhat ductile and malleable, pyrophoric in powd form; mp $1842 \pm 30^\circ$, 1690° (sep values); bp $\sim 4500^\circ$; d 11.3-11.7 g/cc. Sol in acids; insol in alkalis and w. CA Registry No [7440-29-1]. Present to the extent of 15ppm in the earth's crust. Occurs in the minerals thorite, thorianite, orangite, yttracrasite and in monazite sand. Prepn is by redn of Th dioxide with Ca. The ignition temp of 270 mesh (53 micron) Th powd is 270° ; it becomes incandescent in Br_2 , Cl_2 , I_2 , ignites in F_2 , and can be ignited in pure CO_2 or N_2 (Ref 6)

Ellern (Ref 4) points out that Th, when alloyed with Ag, Cu, or Au, becomes much more ignitable, bursting into flame on rubbing. Th-Ag alloys in approx 1:1 proportions are actually self-igniting (Ref 5). M. Jacobson et al (Ref 2) indexed the explosibility of both Th and Th hydride dusts based on ign temp, spark energy for ign, min expln concn, expln press and rate of press rise as compared with Pittsburgh seam coal, and report that both of these dusts have "severe" explosibility indices of >10

Scurlock et al (Ref 3) claim that the presence of approx 40% free metallic Th or Th hydride in a proplnt formulation will maximize the impulse obtained from a fixed volume of proplnt by burning to yield CO, Th oxide and free H_2 . Compn requirements include an oxidizer such as Amm perchlorate, added in sufficient quantity to give an "oxidn ratio" of 0.48-0.60 (The ratio being defined as $\text{O}/[\text{O}+\text{C}+2\text{Th}]$, where O, C and Th are the number of atomic equivalents of O, C and Th in the compn). A typical formulation would include Th powder (ca 40), polyvinyl chloride (ca 7), dioctyl phthallate (ca 8), AP (ca 44) and a wetting agent (ca 0.25%)

Lantz (Ref 8) states that double-base proplnts having low flame temps and burning rates, and having mesa-plateau-shaped burning rate vs pressure curves can be prepd by the incorporation of 2.5 to 3.5% Th or a Th compd, preferably an organometallic compd such as Th stearate into a compn contg NC 40-60, NG 10-30, inert plasticizer 10-30, ethyl centralite 1-5, C black 0.02-0.1, HMX 0-10%, and enough ethyl alc to assure easy blending

Zavitsanos et al (Ref 9) claim the invention of an expl which liberates high amts of thermal energy at extremely high temps ($>4000^\circ\text{K}$), and can be used to simulate the thermal effects of nuclear explns. It is prepd from Th and MoO_3 (avg particle diameter 50-100 μ). The molecular structure and energy levels for Th and Th oxides used in the first law of thermodynamics calcs, and the equivalent compn and enthalpy of combustion products of the Th- MoO_3 system are given in the ref

Th and its compds are toxicologically inert on the basis of its chemical toxicity. Only 0.001% of an ingested dose is retained in the body. Th, once deposited in the body remains for long periods of time. It has a predilection for

bones, lungs, lymphatic glands, and parenchymatous tissues. Characteristic effects of the activity of Th and its disintegration products are changes in blood forming, nervous and reticuloendothelial systems, and functional and morphological damage to lung and bone tissue. Only much later do illness and symptoms characteristic of chronic radiation disease appear. After a considerable time, neoplasms may occur and the immunological activity of the body may be reduced. External radiation with gamma rays can occur from contact with material containing mesothorium, with Th in large quantities, and with by-products that contain disintegration products of Th. Th dioxide (thorotrast) is known to cause severe radiation damage and cancer of bone, blood vessels, liver, and other organs when administered to patients for diagnostic purposes. Its use is now forbidden for introduction into body tissues (Ref 10)

The max permissible concn for Th under the US Federal Standard is 1×10^{-6} micro Curies/ml (air) (Ref 10)

Thorium hydride (ThH_2), when deposited in thin layers, will ignite at room temp within a few minutes after exposure (Ref 4, p 32)

Thorium nitrate [$\text{Th}(\text{NO}_3)_4 \cdot 4\text{H}_2\text{O}$] was used, together with Mg powd, in early illuminating flashes for photography; it was also patented for use in a pyrot flare formulation (Ref 4, pp 115 & 340). Ref 7 states that contact of Th nitrate with easily oxidizable substances may easily flash or cause violent combustion or expln. In addition, toxic nitrogen oxide gas is generated in the event of a fire. Its toxic dose level (TDL) is LD_{50} abd-rat, 68mg/kg

For information on Th picrate, see Vol 8, P283-R

Refs: 1) Gmelin, Syst Nr 44, Teil C2 (1976)
 2) M. Jacobson et al, BuMines Rept **6516** (9) (1964) & CA **61**, 13117 (1964) 3) A.C. Scurlock, K.E. Rumbel & M.L. Rice, BritP 1059261 (1967) & CA **66**, 106748 (1967); USP 3326732 (1968) & CA **68**, 31692 (1968)
 4) Ellern (1968), 32, 40, 115 & 340 5) J.R. Gibson & J.D. Weber, "Handbook of Selected Properties of Air- and Water-Reactive Materials", **RDTR 144**, Naval Ammo Depot, Crane (1969), 24 & 35 6) Bretherick (1975), 947
 7) Anon, "Toxic and Hazardous Industrial Chemicals Safety Manual", International Tech-

nical Information Institute, Tokyo (1975), 521
 8) R. Lantz, USP 3923564 (1975) & CA **84**, 108003 (1976) 9) P.D. Zavitsanos, M.M. West & W.G. Brown, USP 4076563 (1978) & CA **88**, 193982 (1978) 10) M. Sittig, "Hazardous and Toxic Effects of Industrial Chemicals", Noyes Data Corp, NJ (1979), 409-11

Thorn, L. Patented in Engl in 1890 an expl prepd by treating a mixt of 2p nitrocresol and 1 p Ba or Sr nitrate with a soln of a soft resin (wax, etc) to obtain a plastic mass. This was followed by graining and drying

The same inventor proposed smokeless powder formulations based on nitrocresol or nitrocresylates

Ref: Daniel (1902), 767

Thread Velocimeter. See under "Benton's Electro-Ballistic Pendulum" in Vol 2, B34-R

Threitol Tetranitrate. See Vol 5, E124-L to E125-L under "Erythritol Tetranitrate"

Through-Bulkhead Initiator (TBI). Through-bulkhead initiators are used to transmit a detonation shock wave through a solid steel bulkhead and initiate a deflagration on the opposite side without perforating the bulkhead or otherwise destroying the integrity of the hermetic seal formed by the bulkhead

Some TBI's are designed to accommodate a standard transfer line bayonet connector. Detonation of the donor transmits a shock wave through the integral steel bulkhead and initiates a receptor charge within the initiator. The output of the receptor charge is attenuated and used to ignite an ignition charge, which can consist of B/K nitrate. The hot gas and burning particles generated by the deflagrating TBI easily ignite any standard rocket ignition pellets or gas generating charges, such as BlkPdr, smokeless powder, granular composite propnnts, and metal-oxidant ignition mixts. The unit consisting of the TBI and the transfer line is non-fragmenting and features a quick-disconnect to facilitate assembly (Ref 3)

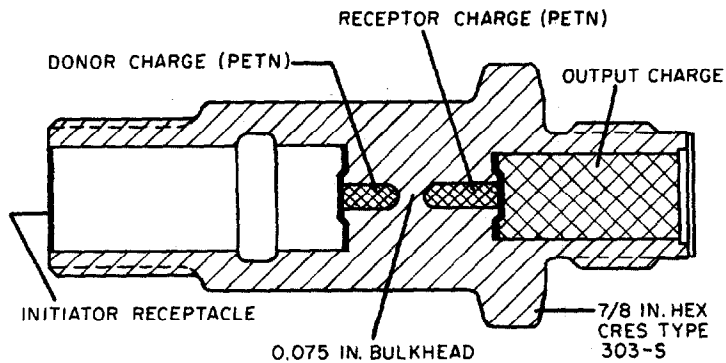

Fig 1 Initial TBI Configuration for Saturn V Launch Vehicle

A typical TBI concept is shown in Fig 1. It is the initial configuration for the Saturn V launch vehicle where the requirement called for maintaining a firm seal after detonation that would withstand 10000psi pressure

The initiator in this instance is a length of detonating cord, donor and acceptor charges are both PETN, and the body is type 303S stainless steel with the bulkhead 0.075" thick. This TBI was developed to initiate solid proplnt rocket motors that are used during stage separation to control the ullage in the main proplnt tanks and to provide retro thrust. The TBI ends are sealed so that the TBI will better withstand the temp environment (Ref 2)

TBI's have the following advantageous features: 1) the need for glass-to-metal seals is eliminated; 2) the need for functional ground checkout, except for simple visual inspection, is eliminated; 3) their insensitivity permits installation during production assembly; 4) they are completely insensitive to radiofrequency, stray currents, or any induced electrical currents, because they are non-electric; 5) since they incorporate all activation energy in the form of chemical reaction, the need for supplementary electric power is eliminated; and 6) the rapid response results in excellent ignition reproducibility and simultaneity between multiple TBI's, which would be very difficult to accomplish by using conventional electro-explosive igniters
 Refs: 1) G. Cohn, Ed, *Expls & Pyrots* 2 (1) & 2 (3) (1969) 2) Anon, *EngrgDesHndbk*, "Explosives Series, Explosive Trains", **AMCP 706-179** (1974), 5-16 3) K.O. Brauer, "Handbook of Pyrotechnics", Chemical Publishing Co, NY (1974), 56-58

Throw-weight. The total weight which a missile can deliver over a stated range and in a stated trajectory. This depends on the power of the booster-sustainer combination as well as on the intended range and the trajectory chosen. Unlike "payload", throw-weight includes the total re-entry vehicle plus guidance unit weight
 Ref: E. Luttwak, "A Dictionary of Modern War", Harper & Row, NY (1971), 76

Thruster. See under "Cartridge-Activated Devices (CAD's)" in Vol 2, C70-R to C72-R

Thunderbird Mk 2. Brit in service mobile medium-to-high level anti-aircraft guided weapon system capable either of being operated independently as a self-contained system or of being integrated into a larger air defense complex

Thunderbird is powered by a solid proplnt rocket motor and four jettisonable solid proplnt boosters. It has semi-active radar homing guidance with control by tail surfaces. The missile carries a HE warhead which is detonated by a proximity fuze

The missile length is 6.35m, body diameter 0.53m, wing span 1.63m, and has a slant range of 75km

Refs: 1) M.J.H. Taylor & J.W.R. Taylor, "Missiles of the World", Charles Scribner's Sons, NY (1976), 148-49 2) R.T. Pretty, Ed, "Jane's Weapon Systems-1977", Franklin Watts, NY (1976), 82-83

Thunder Powder. An expl compn obtained by incorporating K chlorate, sawdust and chalk into a nitrated mixt of glycerin and honey
 Refs: 1) Cundill (1889) in **MP 6**, 103 (1893) 2) Daniel (1902), 767

Thunderites. Mining expls containing AN 91 to 93, TNT 3 to 5 and flour 3 to 5%. The vel of deton for a confined charge at a d of 1.07g/cc was 3650m/sec; the heat liberated was 777kcal/kg
 Refs: 1) Daniel (1902), 767 2) Marshall 2 (1917), 493 3) Barnett (1919), 118, 195 & 199

Tigercat. Brit close-range surface-to-air missile system, in production and service. This system was evolved specifically as a simple guided weapon with instant readiness for the point defense of airfields and other important potential target areas on land

In its mobile form, Tigercat comprises a three-round launcher-trailer and a director trailer, housing the optical sighting and launch control equipment. In operation, after the target has been acquired by the aimer and the missile fired, the aimer uses a thumb-operated controller to guide the missile along the line-of-sight to the target. By integrating the system with target tracking radar, it can be given day and night all-weather capability

The warhead is HE with proximity fuze. The missile length is 1.48m, body diameter 0.19m, launch weight 60kg, and slant range 3500m
Refs: 1) M.J.H Taylor & J.W.R. Taylor, "Missiles of the World", Charles Scribner's Sons, NY (1976), 149-50 2) R.T. Pretty, Ed, "Jane's Weapon Systems-1977", Franklin Watts, NY (1976), 83-84

Tiger Computer Program. See under "Computers and Computer Programs" in Vol 4, D180-L to D186-L

Time on Target. 1) Term used to describe the method of firing on a target in which various artillery units so time their fire as to assure all projectiles reaching the target simultaneously; 2) A measure of the ability of a fire control system and/or gunner to keep a weapon aimed at a moving target or to keep a weapon mounted on a moving vehicle aimed at a target. A useful evaluation of weapon stabilizers

Ref: Anon, OrdnTechTerm (1962), 312

"Timing Systems and Components". The title of a US Army Materiel Command handbook (Ref 1) on timing systems and their components which discusses every conceivable mechanism to achieve a time delay. Included are all of the design factors, production methods, materials needed, setting methods, and other subjects of interest to the military

The main timer types are precision reference, electronic, mechanical, pyrotechnic, flueric and electrochemical. Also covered are fluid timers (not to be confused with flueric timers) and nuclear decay timers. Electronic and flueric timers are similar in that they both use oscillators, amplifiers, and related networks to achieve timing and frequency control. In mechanical

Table 1
General Characteristics of Timers

Features	Precision Reference	Electronic	Mechanical	Pyrotechnic	Flueric	Electrochemical
Input to start	Voltage pulse	Voltage	Voltage or mechanical	Voltage, flame or firing pin	Fluid pressure	Voltage, chemical release
Time base	Crystal or atomic	Oscillator	Escapement, motor, tuning fork	Pyrotechnic burning rate	Oscillator	Rate of chemical reaction
Time range	10^{-9} sec to years	10^{-3} to 10^3 sec	Seconds to days	10^{-3} to 10^3 sec	1 to 10^3 sec	Minutes to days
Accuracy	1 part in 10^6 to 1 part in 10^{12}	$\pm 0.1\%$	$\pm 5\%$ to 1 part in 10^6	$\pm 10\%$	$\pm 1\%$	$\pm 4-10\%$
Output	Voltage pulse or time interval	Voltage	Mechanical	Flame	Fluid pressure, voltage	Chemical reaction, voltage, chemical

timers, these functions are performed by clockworks and escapements (Table 1). Component design and the materials needed vary greatly between types

All of the timing systems and components discussed are of ordnance interest. Many of the timers are components of ammo, fuzing or control devices. Particularly in fuzes, where delays are crucial to safe and effective performance, timers are almost always present. Timers for most safing and arming devices, being mechanical, are also covered

Refs: 1) Anon, *EngrgDesHndbk*, "Timing Systems and Components", **AMCP 706-205** (1975), 510 pp, (ADA 020020) 2) G. Cohn, Ed, *Expls & Pyrots* **9** (4) (April 1976)

Tin. (Stannum). Sn; at wt 118.69; at no 50; valence 2, 4; ten naturally occurring isotopes: 112 (0.95%), 114 (0.65%), 115 (0.34%), 116 (14.24%), 117 (7.57%), 118 (24.01%), 119 (8.59%), 120 (32.97%), 122 (4.71%) and 124 (5.98%); artificial radioactive isotopes: 108–111, 113, 121, 123 and 125–132; almost silvery-white, lustrous, soft, v malleable and ductile metal; only sl tenacious, easily powdered, emits the crackling "tin cry" when being bent; brittle at 200°, crumbles at -40° to a grey amorph powder ("grey tin") and slowly changes back above 20° to white tin; mp 231.9°; bp 2507°; d 7.31g/cc. Reacts with concd HCl, hot caustic alkali and aqua regia; reacts slowly with cold dil HCl, cold caustic alkali, dil nitric acid and hot dil sulfuric acid; reacts v slowly with acetic acid; insol in w. CA Registry No [7440-31-5]. Occurs to the extent of $6 \times 10^{-4}\%$ in the earth's crust. Found in cassiterite, stannite and tealite. Comml prepn is by roasting the ore (cassiterite) to oxidize sulfates and to remove arsine, then reducing with coal in a reverberatory furnace or by smelting in an electric furnace

Tin has been used in smokeless propnlts as an anti-barrel fouling agent (*Refs* 2 & 3), and in electrically functioned pyrot delay compns for millisecond delays to space expl action in mining operations (until fused, the delay compns contg the Sn alloys are electrically non-conductive) (*Ref* 4)

According to Merck (*Ref* 7) all *organic* compds of tin are toxic. The max allowable tolerance level

(as Sn) in air for such compds is 0.1mg/m³ of air

The US Military Specification for pulverized tin is **MIL-T-458A** (*Ref* 6)

Refs: 1) Gmelin, *Syst Nr* 46, Teil A (1971) 2) Stettbacher (1948), 43 3) S. Sitelman, "Determination of Tin in Smokeless Powder . . .", **FATR 3948** (1953) 4) Ellern (1961), 238 5) G. Brauer, Ed, "Handbook of Preparative Inorganic Chemistry", Vol 1, 2nd Edn, Academic Press, NY (1963), 727 6) Anon, "Tin, Pulverized", **MIL-T-458A** (28 Apr 1969) 7) Merck (1976), 1218 (No 9171) 8) *Cond-ChemDict* (1977), 864

Tin Nitrate. See in Vol 8, N39-R

Tin Oxide. See in Vol 8, 051-R under "Stannic Oxide"

Tipo C Amononal. An expl contg AN 76, Al 13 and amm thiocyanide 11%, used for press-loading projectiles during the Spanish Civil War

Tipo S Amononal. An expl contg AN 86, Al 8 and stearin 6%, used for cast-loading projectiles during the Spanish Civil War

Ref: Vivas, Feigenspan & Ladreda **2** (1946), 406

Titan Dynamite. US Dynamite contg 40–50% NG absorbed by a mixt of K and Na nitrates, sulfur, charcoal and ligneous materials

Ref: Daniel (1902), 768

Titanium. Ti; at wt 47.90; at no 22; valence 2, 3, 4 (mostly tetravalent); five natural isotopes (mass numbers): 48 (73.94%), 46 (7.93%), 47 (7.28%), 49 (5.51%), 50 (5.34%); artificial isotopes: 43–45, 51; dark grey, lustrous metal; dimorphic- α -form is hexagonal below 882.5° (D_{6th}^4 , a=2.951, c=4.692, 2 atoms/cell); β -form is body-centered cubic above 882.5° (a=3.283); brittle when cold, malleable when hot, ductile only when free of O₂, traces of O₂ or N₂ increase strength; mp 1677°; bp 3277°; d (α -form) 4.506g/cc at 25°, (β -form) 4.400g/cc at 900°. Attacked only by concd sulfuric & hydro-

chloric acids; insol in w, most solvents and reagents. CA Registry No [7740-32-6]. Ninth most abundant element in earth's crust (0.63% by wt). Occurs as the oxide in minerals rutile, ilmenite, perovskite, anatase or octahedrite and brookite; also in sphene or titanite (CaTiSO_5) and benitoite ($\text{BaTiSi}_3\text{O}_9$). Prepn is by either: a) Redn of TiCl_4 with Mg (Kroll process) or Na in an inert atm of He or Ar. The Ti sponge is consolidated by melting; b) Electrolysis of TiCl_4 in a bath of fused salts (alkali or alkaline earth chlorides)

Solid Ti can be deton by friction when in contact with red fuming nitric acid (Ref 3) and will burn in air at $700\text{--}800^\circ$. Powdered Ti (<200 mesh) is pyrophoric. It can be deton by electric spark (10 mj) in air, N_2 or CO_2 (Refs 2 and 6a). It ignites in air at 250° and will burn in an atm of N_2 above 800° or in CO_2 above 550° . The application of w to burning Ti can cause an expln (Ref 8). Solid Ti can react explosively in the cold with metal carbonates. In the powdered form, Ti can react explosively when heated with K chlorate, nitrate or permanganate. Mixts of powdered Ti and LOX are also extremely expl (Ref 12)

Lyons (Ref 4) reports on a Universal Match Corp program to develop igniter-propellant compns using an M-7 propellant base; viz, NG 24.8, NC 36.6, ethyl centralite 0.56, Mg 0.04 and Mg stearate 0.04%, plus either AP or K perchlorate 10%. To these two matrixes 30% of powdered Ti was added giving the parameters shown in Table 1. The authors noted that the advantages of these compns are that they are reproducible, have a high rate of hot particle evolution with reliable high energy output, and are safe to handle

According to Ellern (Ref 6, pp 83 & 185), Ti is an important pyrot fuel which provides a brilliant white light; he also considers it one of "... the most easily ignitable ($200\text{--}350^\circ$), stable and heat retentive fuels in modern first fires ..." (pp 135 & 211), "... high in calorific output ..." (p 251). In Ref 9, p 296, he reports the ign temp of Ti "flowers" as $>190^\circ$, and on p 332, "... as to intrinsic hazardousness ... zirconium is frequently the cause of serious accidents, while ... titanium rarely is ...". He also reports on several Ti-contg formulations which are presented in Table 2

Table 1
Parameters of Igniter-Propellant Compositions Incorporating Titanium

Compn & %	M-7 base, 60	M-7 base, 60
	AP, 10 Ti, 30	K perchlorate, 10 Ti, 30
Autoign Data	Flash <90 sec at 220° ; "No Fire"/30 min at 210°	Flash <90 sec at 220° ; "No Fire"/30 min at 210°
Compressibility, %	37	38
d, lb/in ³	0.0738	0.0747
Q _e , cal/g	1430	1426
Strand Burning Rates at the Stated PSI Levels, inches/sec		
500	0.472	0.474
1000	0.895	0.850
1500	1.229	1.231
2000	1.460	1.620
2500	1.771	2.030
3000	2.061	2.510

Table 2
Titanium Containing Pyrotechnic Formulations

Compn Title	Compn, %
First Fire X (W/B)	Si, 25 Red Lead, Pb_3O_4 , 50 Titanium, 25
First Fire (B2-56)	Si, 25 Red Lead, 25 Titanium, 25 Red Iron Oxide, 25
"Trichloral" Rocket Igniter Mixture	Al (Reynolds I-511), 20 Titanium, 13 K perchlorate, 63 Vistanex (Polyisobutylene), 4

Also, according to Thellmann (Ref 16), there is an economic advantage over other fuels to the utilization of both powder metallurgy (PM) and Ti in the mfg of pyrot incendiaries. "... titanium delivers more BTU's per pound, more BTU's per cubic inch, lower cost per cubic inch, more

BTU's per dollar, and lower cost per pound . . .". For more info on the use of Ti in pyrots see Vol 8, P510-R to P512-R under "Incendiaries"

Thellmann reports in Ref 16 on the non-energetic ordn applications of Ti fabricated into components by PM. These include a Ti sonar reflection plate, 20mm shell casings, fastening bolts of Ti and a Ti-6Al-4V lens housing for the Maverick missile

The pertinent US Military requirements (Ref 15) for Titanium, Type I (for use in pyrots) and Type II (for use in the M36 bomb clusters) are shown in Table 3 below:

Table 3
US Military Requirements for Powdered Titanium,
Technical Grade, Types I and II

Parameter	Requirements	
	I	II
Type		
Assay as Ti, % ^a	94% min	96.5% min
Burning time, sec ^b	40min to 180 max	90 min to 220 max
Particle size, % ^c	95% min thru a No 200 (74 micron) sieve	same as Type I
Mean Surface Diam, microns ^d	—	5 min to 12 max

Footnotes to Table 3:

a—by K permanganate redox titrimetry of an aq Ti sulfate soln

b—by timing the burning of a column of sample 0.328±0.006" in diam x 10.0" in length

c—by sieving a 100g sample thru the No 200 sieve using a mechanical shaker geared to produce 300±10 taps of the striker/min and weighing both the retained and passed portions of the sample. Calcn is as % passed thru the sieve

d—by method 100 of MIL-STD-1233

Refs: 1) Gmelin, System Nr 41 (1951)

2) I. Hartman & H.P. Greenwald, "The Explosibility of Metal-Powder Dust Clouds", *Mining & Met* 26, 331–35 (1945) & *CA* 40, 2629 (1946)

3) P.M. Ambrose et al, "Investigation of Accident Involving Titanium and Red Fuming Nitric Acid", *USBMInfCirc* 77 (11) (1955) & *CA* 49, 7853 (1955) 4) R.B. Lyons, "Research and

Development of Improved Igniter Materials", Final Summary Rept (18/5/59–17/2/60), Universal Match Corp, St Louis, Contract No NOrd 18894, Task I (1960) 5) B.J. Alley & W.W. Howard, "Chemical Analysis of Trichloral (TCA) Igniter Mixtures", *ARGMATR 1D3R* (1960) 6) H. Ellern, "Modern Pyrotechnics . . .", Chemical Publ Co, NY (1961), pp 45, 83, 135, 144, 147, 185, 189, 192, 211 & 251 ff 6a) Anon, *EngrgDesHndbk*, "Part Three—Properties of Materials Used in Pyrotechnics Compositions", *AMCP 706-187* (1963), 303–06 7) G. Brauer, Ed, "Handbook of Preparative Inorganic Chemistry", Vol 2, 2nd Edn, Academic Press, NY (1965), 1161–72 8) Sax (1968), 1166 9) H. Ellern, "Military and Civilian Pyrotechnics", Chemical Publ Co, NY (1968), pp 195, 247, 296 & 332 ff 10) R.K. Ognev et al, "Modern Methods of Obtaining Titanium Powders, and Prospects for Their Use in Industry", *FTD-HT-23-390-70* (1970) 11) V.A. Garmata et al, "The Metallurgy of Titanium", *FTD-HC-23-352-69* (1970) 12) Bretherick, "Handbook of Reactive Chemical Hazards", CRC Press, Cleveland (1975), 948–50 13) Merck (1976), 1219 (No 9180) 14) *Cond-ChemDict* (1977), 865 15) Anon, "Titanium, Technical, Powder", *MIL-T-13405D* (25 Jul 1977) 16) E.L. Thellmann, "Titanium Powder Metallurgy Uses", *Natl Defense LX11* (346), 314–15 (Jan–Feb 1978)

Titanium Dioxide. See in Vol 8, O52-L & R

Titanium Hydride. TiH₂; mw 49.92; blk metallic powdr, stable in air; mp 400° (decompn evolves H₂ initially above 288° and is practically complete at 650°); d 3.76g/cc. CA Registry No [7704-98-5]. Prepn is by: a) direct combination of Ti with H₂; or b) redn of TiO₂ with Ca hydride in the presence of H₂ above 600°. The hydride may expld in the presence of oxidizing agents. However, Ellern (Ref 1, p 252 and Ref 2, p 333) considers the hydride safer to handle than Ti, reporting that dry shipment is possible, ". . . unfortunately . . . greater inertness shows itself also in lower ignition sensitivity and a slower burning rate, which (he feels) limits . . . (its) usefulness (of TiH₂ in pyrots) . . ."

Matle (Ref 1a) reports on the effect on blast produced by the addn of the hydride to Comp B. The compn Comp B/TiH₂ (70/30) was found to be equivalent to 0.89±0.03 of H-6 (a std of 1.00) in terms of peak overpressure and 0.82±0.07 in terms of positive impulse
 Refs: 1) H. Ellern, "Modern Pyrotechnics . . .", Chemical Publ Co, NY (1961), 252 1a) C.C. Matle, "The Air Blast Performance of Mixtures of Composition B and Titanium Hydride and Composition B and Zirconium Hydride", NAVORD 4418 (1957) 2) H. Ellern, "Military and Civilian Pyrotechnics", Chemical Publ Co, NY (1968), 333 3) Merck (1976), 1220 (No 9183) 4) CondChemDict (1977), 866

Titanium Perchlorates. See in Vol 8, P169-L & R

Titanium Tetrachloride. TiCl₄, mw 189.73; colorl liq, penetrating odor, fumes strongly when exposed to moist air forming a dense white persistent cloud (see below); fp -30°; bp 136.4°; d 1.760g/cc at 0°. Sol in dil HCl, dichloroethane and w (with evoln of heat). CA Registry No [7550-45-0]. Prepn is by heating TiO₂ (or the ores) and C to redness in a current of chlorine

The principal use for the tetrachloride is in pyrots as a smoke agent (called "FM"). Ref 5 reports that the tetrachloride ". . . is extremely reactive resulting in the formation of hydrated oxides, or with atmospheric moisture and, when used for screening, is often disseminated from aircraft spray tanks. Its reaction with water vapor is relatively complex. First, the titanium tetrachloride is hydrated. This reaction is followed by further hydrolysis yielding, finally, titanium hydroxide and HCl. The smoke consists of a mixture of fine particles of solid titanium hydroxide, Ti(OH)₄; the hydrated oxide, TiO₂·H₂O; intermediate hydroxychlorides of titanium; and dilute HCl droplets. The sequence of reaction is:

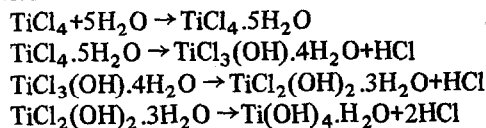

Liquid FM is excessively corrosive to metal if moisture is present. With moisture, FM forms

a solid, gummy deposit that clogs equipment. A 0.2% phosphorous solution in CS₂ and CCl₄, added to the FM, alleviates this problem.

Titanium tetrachloride can also be disseminated when dissolved in dichloroethane and similar materials. The solid evaporates and the titanium tetrachloride reacts with water vapor in the air to produce smoke . . ."

Further, Ellern (Ref 2, p 106) points out that the tetrachloride can be dispersed mechanically or explosively and, of course, in Ref 4, p 149, that the best and fastest obscuration is obtained in humid air. Schladt (Ref 1a) reports on the development of white smoke signals, while Tatyrek (Ref 3) reports on the development of various colored smokes (yel, violet, blue and green) using mixts of chromyl chloride or vanadyl chloride with 20% TiCl₄, and 50/50 mixts of TiCl₄ with hydrazine or thiocyanic acid. A current development is summarized by Stokes et al (Ref 7) on the use of the white smoke formed by TiCl₄ as an optically observable tracer of changes in wind rate and intensity below the turbopause, and molecular diffusion coefficients and densities above the turbopause at altitudes of from 70 to 90km. The dispersing rocket used was so designed that the smoke components, TiCl₄ 68, trimethyl Al 3.25 and w-methanol (36/64%) 59 lbs were loaded into separate (pressurized) tanks and mixed in-flight during dispersion by means of concurrent metering valves leading into a single exit nozzle. The authors report that the optical tracer program allowed the transport parameters in the mesosphere and lower thermosphere to be measured during a period of anomalous radio absorption

Sax (Ref 6) considers the tetrachloride highly corrosive to the skin

For more information about TiCl₄ see in Vol 8, P507-L to P508-R, under ". . . 2) Colored and White Smoke . . ." in the entry on "Pyrotechnics"
 Refs: 1) Gmelin, Syst Nr 41 (1951), 310 ff 1a) G.F. Schladt, "Development of Composition for White Smoke Puff Ground Signals", PATR 134 (1931) 2. H. Ellern, "Modern Pyrotechnics . . .", Chemical Publ Co, NY (1961), 106 3) A.F. Tatyrek, "The Production of Colored Smokes from Highly Reactive Hydrolyzable Metal Chlorides", PATM 1644 (1965) 4) H. Ellern, "Military and Civilian Pyrotechnics", Chemical Publ Co, NY (1968),

149 & 152 5) Anon, *EngrgDesHdbk*, "Military Pyrotechnic Series, Part One, Theory and Application", **AMCP 706-185** (1967), 7-23 to 24 6) Sax (1968), 1167 7) C.S. Stokes et al, "Chemical Release Payloads for the Winter Anomaly Program (1976), Ice Cap Program (1976) and Operation Harses (1976)", **AFGL-TR-76-0312**, Germantown Labs, Phila, Contract F19628-76-C-U056 (1976) 8) Merck (1976), 1220 (No 9188) 9) *CondChemDict* (1977), 866

Titan II Missile (LGM-25C). US intercontinental ballistic missile, in service. The USAF Strategic Air Command originally deployed two huge liq-proplnt ICBMs, Atlas and Titan. Titan I became operational in 1962 and was joined by Titan II in the following year. This was by far the most formidable of all US first-generation long-range missiles. It could be stored in, and launched from, an underground silo, and carried the largest H-bomb warhead that has ever been fitted to a US missile. As a result, the USAF decided to retain six squadrons of Titan IIs, with a total of 54 missiles, although its original intention had been to withdraw all liq-proplnt ICBMs from service as the Minuteman (see Vol 8, M143-R to M144-L) force became operational

The re-entry vehicle carried by each missile is so designed that its speed and trajectory are corrected by four small vernier rockets before it separates from the burned-out second stage. It carries advanced penetration aids to make detection and destruction by an ABM extremely difficult

Titan II's length is 31.40m, max body diameter 3.05m, launch weight 149690kg, max speed 27360km/hr, and max range 11670km
Refs: 1) M.J.H. Taylor & J.W.R. Taylor, "Missiles of the World", Charles Scribner's Sons, NY (1966), 150 2) R.T. Pretty, Ed, "Jane's Weapon Systems-1977", Franklin Watts, NY (1976), 23

Titanites. Fr expls contg AN, TNT (with/without DNT) and charcoal from curcuma, eg: a) AN 78, TNT 12 and charcoal 10%; b) AN 82, TNT 12, DNT 4 and charcoal 2%. These two formulations were suitable for any type of

blasting except in gaseous coal mines. A composition contg AN 87, TNT 4, Na chloride 3 and charcoal 6% was used in gaseous coal mines (Ref 1)

Ref 2 states that *Titanits* were Rus pre-WWI mining expls contg AN 77.4-87.72, TNT 1-12 and burned curcuma 10.56-11.88%

Refs: 1) H. Dautriche, *MP* 16, 212-14 (1911-1912) 2) Anon, *SS* 12, 408 (1917)

TLP (Ger). Treibladungspulver (gun proplnt). The following suffix designations, eg, TLP/A indicate: A-E=single base powder; A=nitrocellulose powder; D=DNT added; F-M=double base powder; F=NC-NG; G=NC-diglycol dinitrate; K=ball powder; N-P=triple base powders; V-W=porous powders

Ref: R. Meyer, "Explosives", Verlag Chemie, NY (1977), 354

TM-1. Nitroammelide (USA). See Vol 1, A273-L

TM-2. Cyanuric Acid (USA). See Vol 3, C589-R

TMA (ATM, Aluminum methyl or Trimethyl aluminum). $\text{Al}(\text{CH}_3)_3$; mw 72.07; colorl pyrophoric liq; mp 15.4°; bp 126°; sp grav 0.752. Sol in many org solvents. Prepn is by Na redn of dimethylaluminum chloride. Flames instantly in air; reacts explosively with acids, alcohols, amines, halogens and w. TMA has a ΔH_c of 762.1 ± 2.3 kcal/mole; Q_c of 10.5 kcal/g and an ign delay of 13msec in air at 232° and 0.16 bar

Murphy et al (Ref 2), Ellern (Ref 5) and Gibson and Weber (Ref 6a) report on the meteorological use of TMA. If released into the atm, TMA produces self-luminous trails (a blue glow) useful for temp measurements, wind velocity measurements, wind shear and turbulence at night. The compd is also used to optically track rockets in flight (Ref 9)

TMA is suggested for use as a pyrophoric fuel in jet engines by Wells (Ref 1a). Fetter et al (Ref 3) suggest TMA in a hydrazine complex as either a proplnt or expl. Prepn of the complex is by dropwise addn (with stirring) of sufficient hydrazine to a pentane soln of TMA at -10° to

form a 1 to 1 adduct. The product, $(\text{CH}_3\text{Al}-\text{NHNH})_n$, a flocculent white ppt, forms when the mixt is allowed to reach RT slowly. The pentane is removed under vac. Fetter et al (Ref 4) also suggest reacting trialkyl Al-trimethylamine complexes with tetramethyltetrazene to produce a rocket fuel. Young and Ehrlich (Ref 7) claim prepn of high-energy, thermally stable, proplnt binders using TMA as an intermediate compd in the prepn. Gluckstein (Ref 7a) suggests a hypergolic rocket fuel consisting of approx 20% TMA and approx 80% TMA chloride. His patent also suggests an appropriate oxidizer for spontaneous ign. Cain et al (Ref 7b) claim a pumpable gelled rocket fuel contg TMA. Thus, 2.3p by wt of TMA are reacted with 1 p of Be hydride at 120° to produce a liq product having a d of 0.72g/cc and a thermal stability (gas evolv) of 5.1×10^{-2} cc/min/lb at 71° , and 1.2×10^{-4} cc/min/lb at RT. The liq product can be gelled by conventional means with 30–50% by wt Be hydride to produce pumpable rocket fuels

According to Sax (Ref 6) TMA has strong irritant properties and high toxicity
Refs: 1) Beil 4, 643 & (1023) 1a) R.A. Wells, "High-Energy Fuels for Aviation", *Mech-Engrg* 80, 55–59 (1958) & CA 52, 21016 (1958) 2) C.H. Murphy et al, "Upper Atmosphere Winds Measured By Gun-Launched Projectiles", *BRL MR-1747* (1966), 11 3) N.R. Fetter et al, "Trialkylaluminum-Hydrazine Complexes", USP 3321503 (1967) & CA 67, 55828Q (1967) 4) Ibid, "Reaction Compounds of Tetramethyltetrazene with Aluminum Trialkyls and Their Amine Complexes and Their Preparation Thereof", USP 3321504 (1967) & CA 67, 55831 (1967) 5) H. Ellern, "... Pyrotechnics" (1968), 164 6) Sax (1968), 392 6a) J.R. Gibson & J.D. Weber, "Handbook of Selected Properties of Air- and Water-Reactive Materials", RDTR 144, NAVAMDEP, Crane (1969), 164 7) A.R. Young II & R. Erlich, "Trialkylaluminumtrialkylamine Adducts as Intermediates for High-Energy Propellant Binders and Thermally Stable Polymers", USP 3538135 (1970) & CA 74, 13743 (1970) 7a) M.E. Gluckstein, "Hypergolic Ignition Method Using Organoaluminum Compositions", USP 3524317 (1970) & CA 73, 100648 (1970) 7b) E.F. Cain et al, "Methyl Alane-Terminated Beryllium

Hydride Liquids", USP 3582414 (1971) & CA 75, 51079 (1971) 8) Bretherick (1975), 373 9) CondChemDict (1977), 886–87

TMA (Trimethylamine or N,N-Dimethylmethanamine). $(\text{CH}_3)_3\text{N}$; $\text{C}_3\text{H}_9\text{N}$; mw 59.13; N 23.69%; OB to CO_2 –175.88%; gas, pungent, fishy, ammoniacal odor, saline taste, liquefiable by press at RT or by condensation; fp -124° ; bp $3.2-3.8^\circ$ at 747mm; d 0.6709g/cc at $0/4^\circ$; RI 1.3631 at 0° . Sol in benz, chl, ethanol, eth, ethyl benz, toluene, xylene. CA Registry No [75-50-3]. A degradation product of nitrogenous plant and animal substances. Lab prepn is by the action of formaldehyde and formic acid on ammonia or by the hydrogenation of trimethyl-allyl-ammonium iodide using PtO_2 in acetic acid or w

Trimethylamine has an autoign temp of 190° , a flash pt of -5° (gas) or 5° (for a 25% wt/vol aq soln), flammability limits of 2.0 and 11.6%, and a Q_c^V of 579.8cal/mole or (Q_c^P) 580.0cal/mole

Lyerly (Ref 6), in his patent claims use of the compd in a liq expl formulation having a deton vel of approx 18600ft/sec, with the following compn: TMA 10, TNT 30, ammonium sulfate 27.6, Na nitrate 14 and w 18.4p

Kazmierowicz (Ref 3) reports on the use of TMA as a rocket fuel, and states that this is one of the world's principal uses of the compd. In studying the effects of additives on the two-stage ignition of cyclohexane and n-heptane in a vertical flow reactor, Moore and Tipper (Ref 7) found that the addn of 6% TMA has a marked promoting effect over nitrogen contg compds such as ammonia, ethylamine, n-propylamine and dimethylamine; unsaturated additives such as propene, 1-pentene, cyclohexene, 1,2-dichloroethylene, ethanol and iso-propanol; halogen compds such as ethyl bromide, chl, CCl_4 and methyl iodide; and other compds such as carbon disulfide. Bartoszek and Mangold (Ref 8) suggest that TMA be used as part of an adduct with AlH_3 as a solid proplnt. Prepn of the adduct is by treating Na-dried decaborane (0.065 mole) in n-pentane with small increments of AlH_3 -TMA adduct (0.130 mole) under nitrogen for over 10 minutes at $0-50^\circ$ with stirring until hydrogen evolv ceases. In a 18–76 hr reaction time 90.6 to 97.6% yield is claimed

TMA is considered by Sax to be of moderate toxicity (Ref 5)

TMA forms several expl salts:

Trimethylamine Nitrate (TMAN). $(\text{H}_3\text{C})_3\text{N}\cdot\text{HNO}_3$; $\text{C}_3\text{H}_{10}\text{N}_2\text{O}_3$; mw 122.1; N 22.95%; OB to CO_2 -104.8%; colorl cryst; mp 153° , 157° (separate values). Sl sol in cold ethanol. CA Registry No [25238-43-1]. The salt has an activation energy of 18.0kcal/mole; a Q_{expln} of 834kcal/kg; an ign (deflagration) temp of 202° ; a sp energy of 86.2mt/kg; and generates a gas vol of 1102 ℓ /kg on deton. Ref 5a claims that high performance, w-contg expl compns having densities $\geq 1.4\text{g/cc}$ are obtained when TMAN~30, AN 35, and w 15p, are first heated with stirring to $54\text{--}60^\circ$. A premix of Na nitrate 15 and guar gum 0.8p, is then stirred in until the mixt is thickened; subsequently, phenolformaldehyde resin balloons 1, S 2 and C 3p are added, followed by the addition of approx 1% K dichromate and 5% K Sb tartrate solns. The stirred material is then poured into molds and allowed to gel. A deton rate of 6300m/sec (5" diam, unconfined) is reported

Trimethylammoniumpentazidodicuprate.

$(\text{CH}_3)_2\text{NH}[(\text{N}_3)_2\text{CuN}_3\text{Cu}(\text{N}_3)_2]$ or $(\text{CH}_3)_3\text{N}\cdot\text{HN}_3\cdot 2[\text{Cu}(\text{N}_3)_2]$ (Refs 2 & 1, resp); dk red cryst; explds at 201°
 Refs: 1) Beil 4, 43, 47, (322), [553] & [99]
 2) M. Straumanis & A. Cirulis, "The Complex Compounds of $\text{Cu}(\text{N}_3)_2$. . .", ZAnorgChem 252, 9-23 (1943) & CA 38, 3563 (1944) 3) W. Kazmierowicz, "Problems of Methylamine in the World and in Poland", FTD-TT-65-1726/1+2+4 (1966) (AD 801029) 4) N.R. Fetter & B.K.W. Bartocha, "Reaction Compounds of Tetramethyltetrazene with Aluminum Trialkyls and Their Amine Complexes and the Preparation Thereof", USP 3321504 (1967) & CA 67, 55831 (1967)
 5) Sax (1968), 1196 5a) C. Duglinson & W.M. Lyerly "Water-Bearing Explosives Containing Nitrogen-Base Salts", USP 3431155 (1969) & CA 70, 116788 (1970) 6) W.M. Lyerly, "Slurry Explosive Compositions Containing Nitrogen Base Salt and TNT, Nitrocellulose Propellant, or Composition B", USP 3629021 (1971) & CA 76, 47952 (1972)
 7) F. Moore & C.F.H. Tripper, "The Effect of Additives on Low-Temperature Hydrocarbon Ignition in a Flow System", Combstn&Flame 19, 81-87 (1972) & CA 77, 141967 (1972)
 8) E.J. Bartoszek & D.J. Mangold, "Compounds Prepared from Aluminum Hydride-Trialkylamine

and Decaborane", USP 3624117 (1971) & CA 76, 47949 (1972) 9) Bretherick (1975), 375 10) Anon, "Fire Protection Guide on Hazardous Materials", 6th Edn, NFPA, Boston (1975), Sect 49, p 196 11) Merck (1976), 1246 (No 9379) 12) R. Meyer, "Explosives", Verlag Chemie, NY (1977), 299 13) S.R. Jain et al, "Thermal Reactivity of Methylammonium Nitrates", PropInts&Expls 1978, 3 (3), 83-87 & CA 89, 148864 (1978)

TNA (1,3,5,7-Tetranitroadamantane).

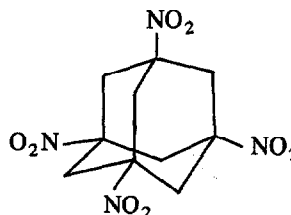

$\text{C}_{10}\text{H}_{12}\text{N}_4\text{O}_8$; mw 316.23; N 17.72%; OB to CO_2 -91.1%; colorl truncated square pyramidal crystals; mp, decompn $> 350^\circ$ without melting; d 1.63g/cc; ΔH_c 3952cal/g

Proposed as an exptl expl by E.E. Gilbert & G.P. Sollott of USA ARRADCOM, Dover, NJ. First prepd by permanganate oxidation of the corresponding tetraaminoadamantane. Calcs indicate an expl output greater than TNT

TNA has a five-second expln temp of 400° . Impact test data show "no go" from 150 to 240cm in the ERL Type 12 tooling app (TNT explds at $65 \pm 5\text{cm}$)

Refs: 1) Beil, not found 2) Anon, C&EN (Jan 1980), 32 3) E.E. Gilbert, Private Communication (Feb 1980)

TNA. Trinitroaniline (USA). See Vol 1, A409-R to A411-L, and update in this Vol under "2,4,6-Trinitroaniline"

TNAmpH. Trinitroaminophenol (USA). See Vol 1, A244-L

TNnd. Trinitroanilide (USA). See Vol 1, A405-R

TNAns. Trinitroanisole (USA). See Vol 1, A450-L to A453-R

- TNB.** Trinitrobenzene (USA). See Vol 2, B48-L to B49-R and update in this Vol
- TNBA.** Trinitrobenzaldehyde (USA). See Vol 2, B35-R
- TNBAc.** Trinitrobenzoic Acid (USA). See Vol 2, B73-L to B75-L
- TNBxN.** Trinitrobenzoyl Nitrate (Ger). See Vol 2, B90-L
- TNC.** Tetranitrocarboazole (USA). See Vol 2, C48-L and update in this Vol
- TNCB.** Trinitrochlorobenzene (USA)
- TNCrs.** Trinitrocresol (USA). See Vol 3, C557-R
- TNDCB.** Trinitrodichlorobenzene (USA)
- TNDMA.** Trinitrodimethylaniline (USA). See Vol 5, D1317-R
- TNEB.** Trinitroethylbenzene (USA). See Vol 6, E212-R to E213-R
- TNEDV.** Trinitroethyldinitrovalerate (USA). See Vol 6, E339-L
- TNETB.** 2,2,2-Trinitroethyl-4,4,4-Trinitrobutyrate (USA). See Vol 6, E217-L
- TNG.** Trinitroglycerin (USA). See in this Vol
- TNM.** Tetranitromethane (USA). See Vol 8, M83-L
- TNMA.** Trinitromethylaniline (USA). See Vol 8, M100-R to M101-R
- TNMeL.** Trinitromelamine (USA). See Vol 8, M56-L
- TNMes.** Trinitromesitylene (USA). See Vol 8, M62-R
- TNN.** Trinitronaphthalene (USA). See Vol 8, N12-R to N14-R
- TNPE.** Tetranitrato de Pentaeritrita; PETN (Span). See Vol 8, P86-R ff
- TNO.** Tetranitrooxanilide (USA). See Vol 8, O36-L
- TNPh.** Trinitrophenol; Picric Acid (USA). See Vol 8, P285-R ff
- TNPhBuNA.** Trinitrophenylbutylnitramine (USA)
- TNPhDA.** Trinitrophenylenediamine (USA). See Vol 8, P240-L
- TNPhENA.** Trinitrophenylethylnitramine (USA)
- TNPhIGI.** Trinitrophenylglucitol (USA). See Vol 8, P248-R
- TNPhMNA.** Trinitrophenylmethylnitramine (USA)
- TNPhMNAPh.** Trinitrophenylmethylnitraminophenol (USA)
- TNPht.** Trinitrophenetole (USA). See Vol 8, P227-L
- TNR.** Trinitroresorcinol; Styphnic Acid (USA). See Vol 5, D1276-R
- TNRS.** Trinitroresortsinat Svintsa; Lead Trinitroresorcinate; Lead Styphnate (Rus). See Vol 5, D1277-L ff
- TNStl.** Trinitrostilbene (USA). See Vol 5, D1455-L

TNT

2,4,6-Trinitrotoluene (α -Trinitrotoluol, *sym*-Trinitrotoluene, 1-Methyl-2,4,6-trinitrobenzene, Trotyl, Tolit, Trilit). $C_7H_5N_3O_6$; mw 227.13; N 18.50%; OB to CO_2 - 73.9%; yel crystals; mp 80.9°

Introduction and Chronology

There are six possible ring-nitrated TNT isomers. The isomer of military interest, the one which is the primary subject of this article, is the

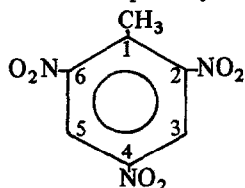

2,4,6-, or "symmetrical" isomer. The five "unsymmetrical", or "meta", isomers are discussed in a separate section; they are all formed

(in amts ranging from a trace to about 2%) during the prepn of military grade TNT. For convenience, the 2,4,6-isomer will be referred to herein simply as "TNT", the meta isomers will always be specifically identified

TNT has a number of advantages which have made it the most widely used of all military expls since before WWI up to the present time. These include low cost from available raw materials, safety in handling (ie, low sensitivity to impact and friction), fairly high expl power, good chemical and thermal stability, favorable physical properties (ie, low volatility and hygroscopicity), compatibility with other expls, a low melting point favorable for melt-casting operations, and moderate toxicity. Main events in the development of TNT are listed below

TNT Chronology:

- 1837 Toluene first described by Pelletier and Walter
- 1841 Toluene mononitrated
- 1863 Crude TNT first prepd by Wilbrand, but constitution not determined
- 1870 First detailed study of the prepn of 2,4,6-TNT by Beilstein and Kuhlberg; 2,4,5-isomer discovered; structures not established
- 1880 Pure 2,4,6-TNT prepd by Hepp
- 1882 2,3,4-TNT first prepd; structure not determined
- 1883 Structure of 2,4,6-TNT established by Claus and Becker

- 1891 Manuf begun in Germany
- 1899 TNT-aluminum mixts proposed for use as expls, but not used because of cost
- 1900 Contact process for making sulfuric acid and oleum developed, thus greatly reducing the manuf cost of TNT
- 1902 Adopted for use by German Army, replacing Picric Acid
- 1912 Adopted for use by the US Army
- 1913 Availability of cheap nitric acid insured by commercialization of the Haber-Bosch process for ammonia synthesis
- 1914 Structure of the 2,3,4- and 2,4,5-isomers established by Will
- 1914-18 Became standard explosives of all armies during WWI. Production limited by availability of toluene from coal tar. Use of Amatols (TNT-Amm Nitrate mixts) became widespread to relieve shortage of TNT. Use of Na sulfite ("sellite") for purification of crude TNT was developed and adopted as standard procedure. Some use of TNT-Al mixts (Tritonals)
- 1930-40 TNT-RDX composites (Cyclotols) developed
- 1939-45 WWII. Development of hydroforming processes for petroleum naphthas insured availability of unlimited quantities of toluene. Improved purification procedures for toluene were also developed. US capacity for producing TNT reached 3.6 billion lbs per year. Widespread use of binary expls (TNT with PETN, RDX, Tetryl, Ammonium Picrate, etc), and of aluminized TNT compns
- 1952 TNT-HMX mixts (Octols) developed
- 1960's Spherical and hemispherical TNT charges up to 500 tons used to simulate nuclear blasts
- 1966 HNS first made from TNT by Shipp
- 1968 First continuous TNT production in the US
- 1978 TATB first made from TNT by Adkins and Norris

Preparation

TNT is made by the stepwise nitration of toluene. The basic factors involved, including a discussion of reaction parameters and of the re-

action mechanism, are reviewed in Vol 8, N40-R to N88-L. TNT can be prep'd on a small scale in the lab by the stepwise nitration of toluene (Ref 1), or more conveniently and in higher purity by the nitration of commercially available 2,4-Dinitrotoluene (Ref 29). The purification of crude TNT is discussed in a separate section below

The commercial manuf of TNT was begun in Germany in 1891, using individual nitrators for the mono-, di-, and trinitration stages. Shortly thereafter, similar batch processes were installed in various countries of the world, including the USA. These processes, differing only in minor details, are described by Urbański (Ref 4). Batch operation was used exclusively in the USA during WWII. As a result of process improvements, production per line reached 65 tons per day by 1945, about fourfold the prewar figure, and the cost dropped from 15 to 6 cents per lb

TNT production ultimately joined the trend of the chemical industry in general toward the continuous manuf of all types of large-volume products, thus making batch nitration methods of historical interest. West Germany provides an exception, as discussed below. Several such processes are generally described under "Continuous Methods for Manufacturing Explosives" in Vol 3, C501-L to C510-L. The advantages of continuous operation include reduced requirements of space and labor, more rapid thruput, higher yields, and better product uniformity and process control. The last factor results in increased safety, of obvious first importance in expls manuf

Serious consideration was given to the continuous manuf of TNT in the USA in 1953 (Ref 2). The known European continuous processes, seven in all, were studied and compared, and the Bofors Norell process was selected as clearly the best. This procedure entailed nitric acid crystn for purification of the crude TNT, as discussed below under "Purification". A second study group again compared available continuous processes in 1967 (Ref 6). They selected the Swedish Nobel-Chematur Process as modified by Canadian Industries Ltd, using Na sulfite for the purification step. After still further modification, three lines based on this concept were installed at Radford AAP, and operation was

begun in 1968. All future TNT requirements will almost certainly be made continuously

This process is generally described in the article on nitration (Vol 8, N53). More specific descriptions (Refs 10, 38 & 39) of it show that 99% nitric acid and 40% oleum are introduced countercurrent to the nitrobody in a series of six stages, the temp and compns of which are given below:

Stage	1	2	3	4	5	6
Temp (°C)	50-55	70	80-85	90	95	100
Composition of Nitrobody:						
MNT	77.1%	—	—	—	—	—
DNT	18.2	70.9	30.4	10.3	1.6	0.2
TNT*	4.2	28.9	69.3	89.5	98.2	99.7

*Includes oxidation products

Each stage includes a 500-gal nitrator and 1 150-gal acid-nitrobody gravity separator for producing 50 tons of TNT per day, except for stages 1 and 3 which each have two nitrators and one separator. This equipment is shown in Fig 1. Yield losses, based on toluene used, are as follows:

Meta TNT isomer formation, %	4
Methyl group oxidation, %	2-3
Oxidative cleavage of ring, %	7-8
During purification, %	2-3
Total, %	15-18

Raw material consumption factors for a typical production line are as follows (Ref 21), per unit of purified TNT produced:

Material	Design	Actual
Toluene	0.470	0.483
40% Oleum	2.118	2.519
99% Nitric Acid	0.547	0.787
60% Nitric Acid	0.955	0.542

The impurities in crude TNT made by the above process are tabulated below in the section on "Purification". They fall into three groups: (1) DNT isomers; (2) oxidation products; (3) meta TNT isomers. The reaction conditions cited above are drastic enough to nitrate nearly all of the DNT isomers (which are not removed by purification and can cause exudation in the finished munition), but not drastic as to lead to excessive oxidation (which constitutes yield loss and introduces impurities). These reactions occur largely in stages 2-6. The formation of meta TNT isomers can be substantially reduced

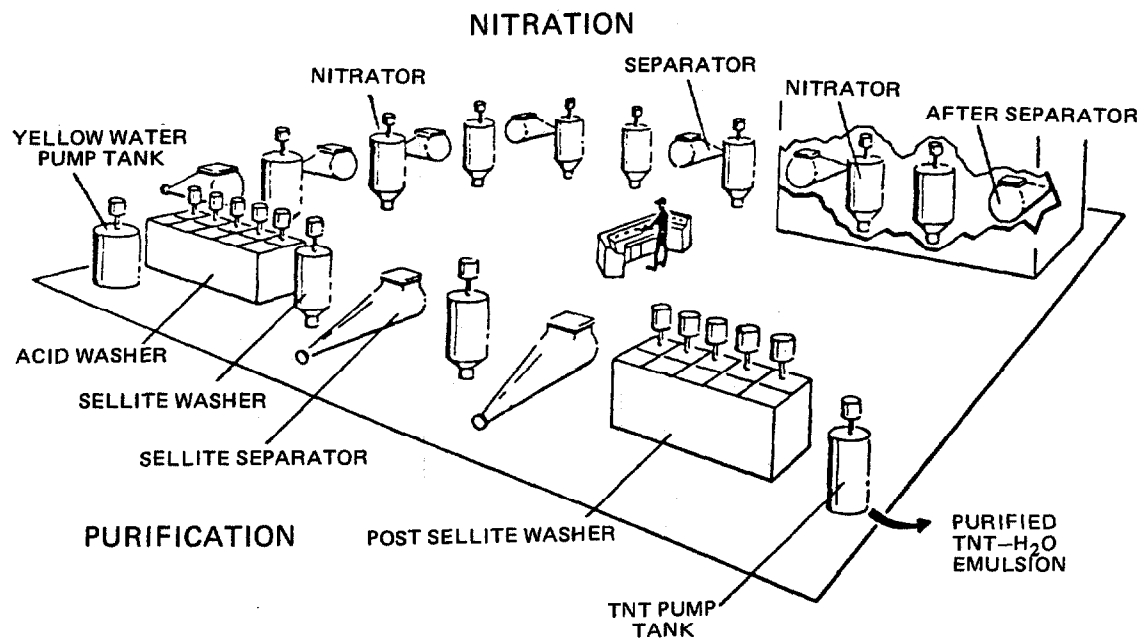

Fig 1 (from Ref 38) TNT Nitration and Purification Equipment Arrangement

by changing the conditions of mononitration, as discussed below

For several reasons, this process has undergone steady modification since its startup. Although the design of this installation was based upon that of a plant already in successful operation, the Radford unit was double the size of the prototype, which necessitated the projection of scale-up factors. As a result, about a year of trial and error operation was required before stable, steady-state production was achieved, yielding specification-grade TNT. Even then, a number of problems persisted, notably higher-than-expected consumption of raw materials as shown in the table above (Ref 39). It was, therefore, concluded that a fundamental process improvement program should be undertaken. The process was computer simulated, based on a fundamentally derived mathematical model in which theoretical equations are employed to represent most of the chemical and physical phenomena which govern the actual nitration process (Refs 16, 27 & 39). The data obtained will permit remote and more precise control by a computer-based system, with resulting minimal requirement for personnel exposure. Another expedient for limiting personnel contact is the

development of continuous, automatic, instrumental on-stream analyzers for process control, thereby avoiding the need for sample retrieval (Ref 32). An on-line liq chromatographic system for automatic analysis of sulfuric and nitric acid in the various separators (Refs 25 & 38) will similarly replace the manual procedure

A second factor indicating a need for process modification was an expln in 1974 which destroyed one of the three continuous lines at Radford: details are given in the article on "Nitration", Vol 8, N84, and below in the section on "Safety and Toxicity". It was then realized for the first time that acid-nitrobody emulsions can be expl; it had been assumed previously that only the separated nitrobody phase was potentially dangerous. Consideration was accordingly given to process modification required to insure maximum safe operation. This was achieved by increasing the number of nitration stages from six to eight, ie, by replacing the six gravity separators (Fig 2) by eight much more effective dynamic (centrifugal) separators (Figs 3 & 4) (Ref 24). This change resulted in cleaner separation of the acid and nitrobody phases, and in drastic reduction of the total quantity of nitrobody present in the building at one time to

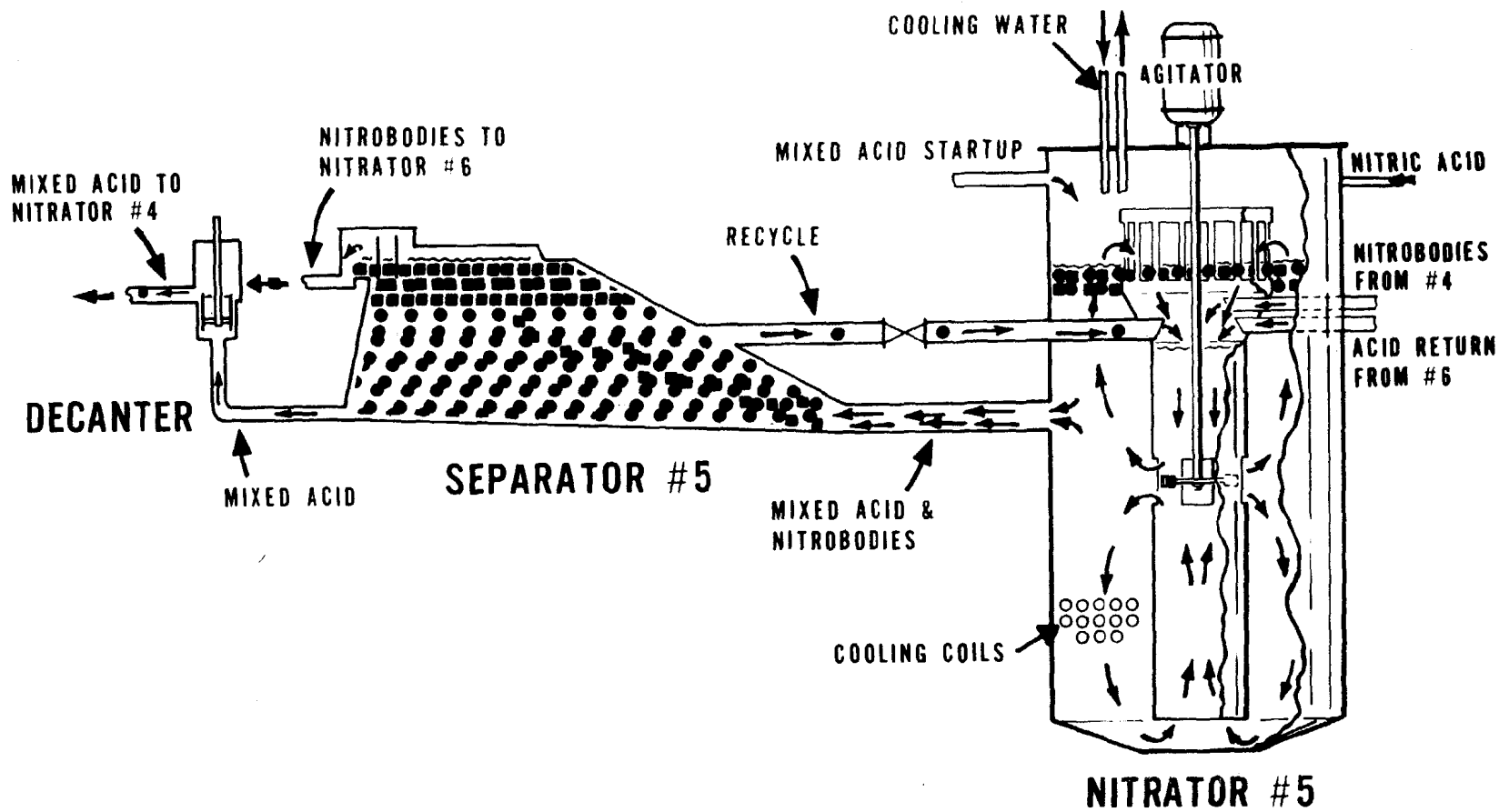

T 238

Fig 2 (from Ref 38) TNT Nitrator System

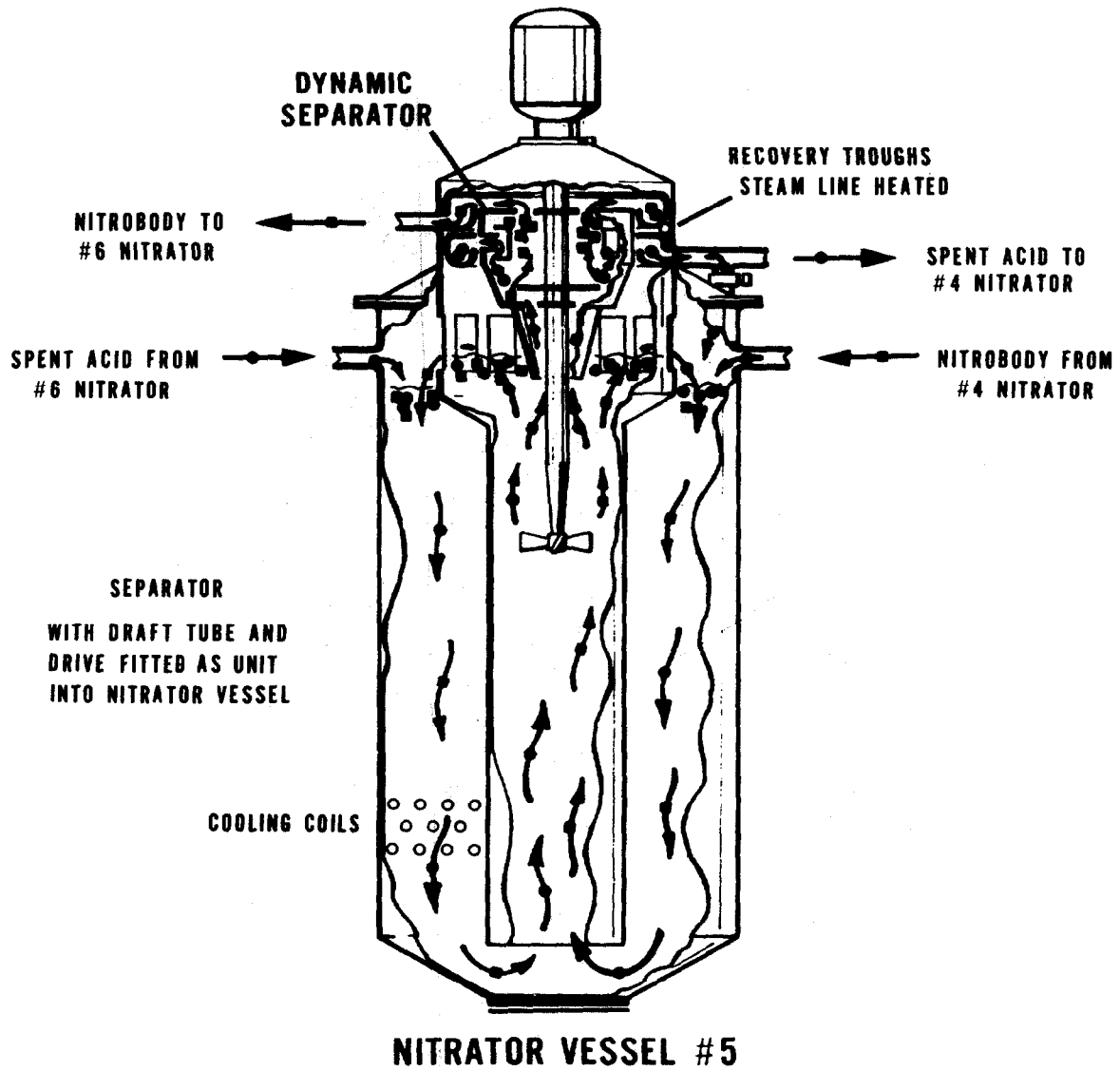

Fig 3 (from Ref 24) Nitrator with Dynamic Separator

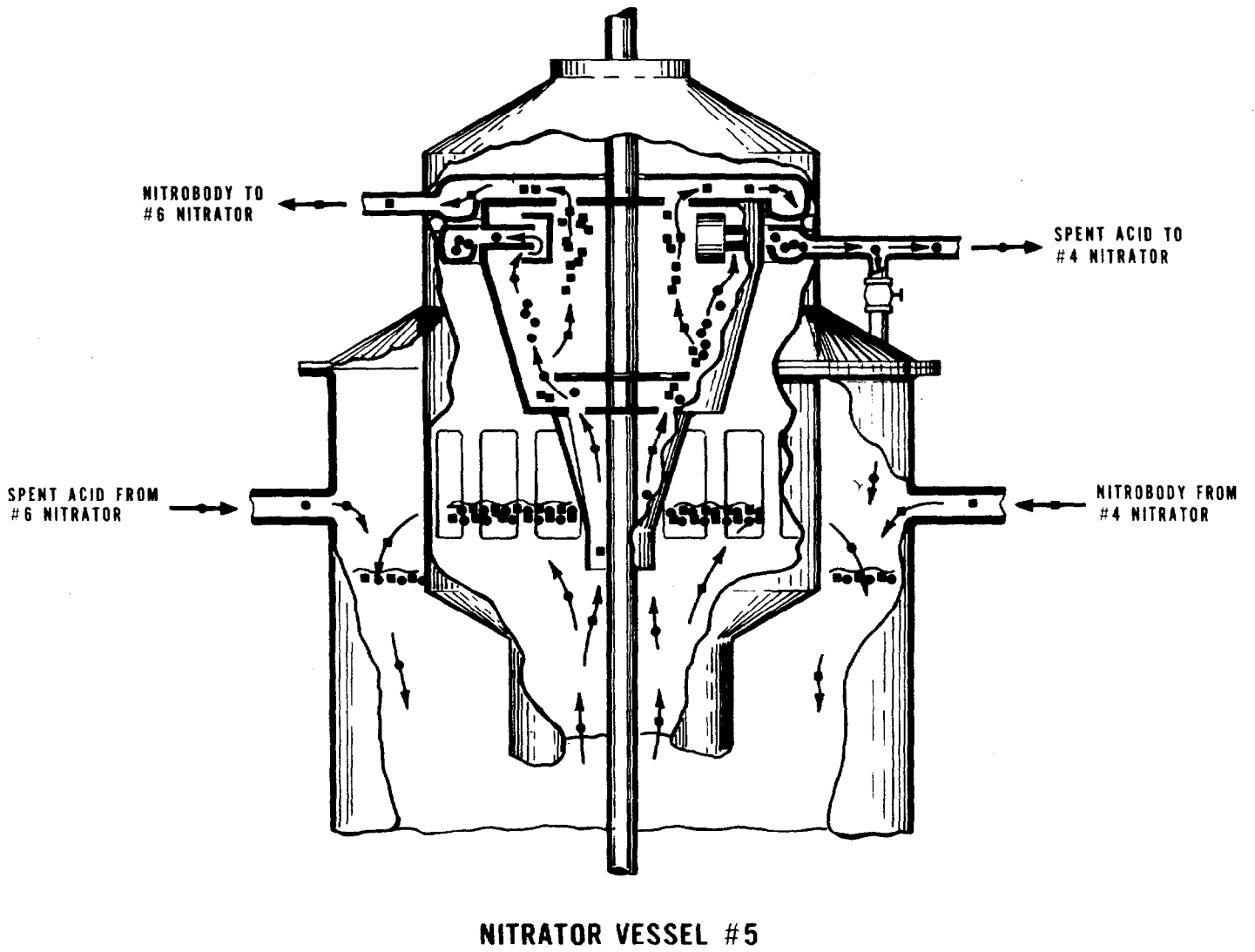

Fig 4 (from Ref 24) Dynamic Separator

40–50% of that present with the use of gravity separators

The expln mentioned above occurred during faulty manual removal of "white compound", an insoluble TNT oxidation by-product, which has periodically coated the nitrator cooling coils (the chemical structure and mode of formation of this material are given under the section on "Chemical Reactions and Derivatives"). It was found (Ref 21) that its formation resulted from high carry-back of TNT oxidation products from one of the nitrators in stage 3 to stage 2. This again pointed to the desirability of cleaner separation of acid and nitrobody, since white compd deposition was not a problem in plants where better separation occurred

White compd is formed by oxidation of the methyl group, which (as shown above) accounts for 2–3% yield loss. A lab study (Ref 37) showed that this type of oxidation is promoted by the presence of stainless steel turnings, and is greater in two-phase systems such as is present under plant conditions. It was reduced by flushing the system with nitrogen to remove NO_2 , which suggests that this may be the species responsible

Studies aimed toward greater safety in TNT production include consideration of the use of suppressive shielding (Ref 26), design of conveyor belts without danger of detonation or propagation (Ref 40), and a study of the possible expl hazard from drowning tank material (Ref 18)

As noted above, the mono- and dinitration stages are normally conducted at 50–70°. Hill and coworkers (Refs 22 & 35) made the important observation that mono- and dinitration at low temp greatly reduces the formation of the objectionable meta isomers, and of ring oxidation products. With mononitration at -110° , followed by dinitration at 0 or 25°, they found that the resulting DNT contained only 0.33% meta isomers, compared to over ten times that amount under the normal conditions. Under practical conditions, these steps would be conducted at no lower than -10° , because of the cost of refrigeration. At this temp, meta isomer formation is about half of the normal amount, thereby correspondingly increasing the product yield and reducing the purification load. A pilot plant for the low temp process was designed (Ref 34) and a dynamic simulation model de-

veloped (Ref 33) to facilitate process startup, control and modification. Further development is not planned, however, since an economic analysis (Ref 30) has shown that the low temp process is more costly than the continuous process operated at a higher temp, even though the former is assumed to alleviate the red water problem

Another design of continuous process in current use is the British ROF Process (Refs 3 & 19). This procedure also involves multistage countercurrent contacting, with the mono-to-trinitration unit comprising a rectangular box-shaped vessel subdivided into eight stirred nitrator stages with intervening unstirred nitrobody-acid transfer sections. Mononitration is conducted separately in a smaller, similar vessel. This design desirably eliminates all interstage pipework and ductwork connections. This equipment applies to the use of 96% sulfuric acid, which requires more staging to effect complete nitration than in the case of the Radford plant discussed above, which employs 40% oleum. A comparison of the two systems (Ref 21) shows that both give an 85% yield based on toluene, and that both have the same nitric acid requirement. Radford usage of sulfuric acid is about 79% that of the ROF process, calculating both on the basis of a strength of 96%. The ROF system employs a lower temp for mononitration, 35–42° vs 50–55° for the Radford process

In West Germany, mononitration is effected by a continuous process, but di- and trinitration are conducted batchwise, because of a high purity requirement (Ref 43). Trinitration is effected with mixed acid comprising 24% HNO_3 , 70% H_2SO_4 and 6% SO_3 ; the reaction requires 6 hours with slowly rising temp. These conditions remove the Dinitrotoluene isomers more completely than is possible with the much shorter reaction time used in continuous operation

A problem associated with TNT production is the disposal of Tetranitromethane (TNM) (see Vol 8, M83-L ff), a toxic, odorous and expl material which is obtained in the exit gas from the trinitration step to the extent of about 0.3–0.5 lbs/100 lbs TNT. TNM was formerly vented to the atm, but this practice is now illegal. It can be recovered by scrubbing the gas with aq Na carbonate containing stabilized

hydrogen peroxide, which converts the TNM to Nitroform (see Vol 8, M78-R) (Refs 28 & 42). Nitroform is a raw material for making energetic plasticizers. Another objectionable effluent from TNT production is oxides of nitrogen (NO_x). These can be removed (> 95%) by oxidation to nitric acid, followed by scrubbing with sulfuric acid (Ref 31)

The following (limited access) references to factors in TNT production are included in the "Refs" section below: 5, 7, 8, 9, 11, 12, 13, 14, 15, 17, 20, 23, 36 & 41

Refs: 1) Davis (1943) 2) J.C.H. Wendes & J.R. Little, "Report on the Known European Processes for the Continuous Production of Trinitrotoluene", Kankakee Unit, JolietArs (1954) 3) W.H. Morris, BritP 885503 (1956) 4) T. Urbański 1, 345 ff, Pergamon Press, NY (1964) 5) C. Grelecki et al, "Production of TNT by Nitration of Toluene: Hazards Evaluation", Rept RMD-2374-F, Reaction Motors Div, Thiokol Chem Corp, Denville, NJ (1969) (Limited distrib) 6) S. Slemrod, "Producing TNT by Continuous Nitration", Ordn (March-Apr 1970), 525 7) W.P. Colman & F.C. Rauch, "Studies on Composition B", Final Rept, American Cyanamid Div, Stamford, Conn (1971) (Limited distrib) 8) A.F. Taschler & S.J. Urban, "Evaluation and Comparison of TNT Produced by Continuous and Batch Processes", PATR 4159 (1971) (Limited distrib) 9) C.W. Marynowski, "Prepilot Feasibility Study of SRI-TNT Process", Final Rept, Stanford Res Inst, Menlo Park (1971) (Limited distrib) 10) W.T. Bolleter, "TNT Process Characterization Studies", Joint US/UK Seminar on TNT Chemistry & Manufacture (26 Oct 1971) 11) H.M. Peters et al, "Improved Synthesis for TNT Production", Final Rept, Stanford Res Inst, Menlo Park (1972) (Limited distrib) 12) Anon, "Joint US/UK Seminar on TNT Chemistry & Manufacture", ERDE-TR-106, Waltham Abbey, Engl (1972) (Limited distrib) 13) Anon, "Computer Control Study of Radford TNT Plant", Final Tech Rept, Chem Systems Inc, NY (1972) (Limited distrib) 14) R.S. Kukuvka & K. Gandhi, "Propagation Tests of 55-Pound Boxes of Bulk TNT and 60-Pound Boxes of Bulk Composition B", PATR 4622 (1973) 15) G. Petino, Jr & D. Westover, "Detonation Propagation Tests on Aqueous Slurries of TNT, Compo-

sition B, M-9 and M-10", Hazards Research Corp, Denville, NJ (1973) (Limited distrib) 16) K.B. Malone et al, "Dynamic Simulation of the Continuous TNT Process", Simulation Council Inc, La Jolla, Ca (1973) 17) D.S. Ross & N.A. Kirshen, "Oxidation in Nitric Acid Systems", Final Rept, Stanford Res Inst, Menlo Park (1973) (Limited distrib) 18) R. Persurance, "Explosive Hazard Classification of Drowning Tank Material from TNT Manufacturing Process", PATR 4613 (1974) 19) Anon, "The ROF TNT Process (New Design)", Royal Ordn Factory, Bridgewater, Somerset, Engl (1974) 20) W.R. Haas, "Design of a Pilot Plant for the Low-Temperature TNT Process", IITRI-C6289-8, IIT Res Inst, Chicago (1974) (Limited distrib) 21) W.T. Bolleter, "Comparison of Processes for Continuous TNT Production", Fifth Annual Seminar on Nitroaromatic Chemistry, PicArsn (11 Sept 1974) 22) M.E. Hill et al, "Process for the Manufacture of TNT", USP 3799993 (1974) 23) G.R. Gibson & R.L. Dickenson, "Sustained Engineering for the Continuous TNT Process", Final Rept PE-328, Hercules Inc, Radford AAP (1975) 24) N.H. Trier & T.N. Mazza, "Decision Risk Analysis for Dynamic Separators", Rept DRSAR/SA/N-37, System Analysis Directorate, USA Arm Command, Rock Isl (1975) 25) C.D. Chandler & W.T. Bolleter, "Liquid Chromatographic Analysis of Nitration Acids", JChromatogr 108 (2), 365-69 (1975) 26) B.W. Jezek, "Investigation into the Use of Suppressive Shielding at Radford Army Ammunition Plant TNT Lines", EM-TR-76002, Edgewood Ars (1975) 27) R. Goldstein, "Computer Simulation of the Continuous TNT Process. Vol 1. The Nitration Section", PATR 4684 (1975) 28) W.H. Gilligan & T.N. Hall, "Removal of Tetranitromethane from Air Streams", NSWC/WOL/TR75-128, Naval Surf Weapons Centr, Silver Spring (1975) 29) W.H. Dennis, Jr et al, JChemEngrgData 20 (2), 202 (1975) 30) N.H. Trier, "Economic Analysis of Low Temperature TNT Processes", Rept SAO-Note-17, USA Arm Command, Rock Isl (1975) 31) P.S. Farber, "Control of Nitrogen Oxide Emissions from TNT Plants", ProcNatlConf-EnergyEnviron 4, 248-52 (1976) 32) M. Halik & C. McIntosh, "New Control Instrumentation for Manufacture of Energetic Materials", PA-TM-2222 (1976) 33) R.W. Hutchinson &

R. Goldstein, "Low Temperature Process for TNT Manufacture. Part 3. Computer Simulation", in *Industrial and Laboratory Nitrations*, ACS Symp Series 22, L.F. Albright & C. Hanson, Eds, ACS, Washington (1976), 290-34) W.R. Haas et al, "Low Temperature Process for TNT Manufacture. Part 2. Pilot Plant Development", *Ibid* (1976), 272-35) M.E. Hill et al, "Low Temperature Process for TNT Manufacture. Part 1. Laboratory Development", *Ibid* (1976), 253-36) A. Wildermann & J.A. Mavec, "Detonation Trap Development Study", *IIT Res Inst, Chicago* (1977) (Limited distrib)

37) R.L. Simon et al, "Oxidation Control in TNT Production", *Final Rept, Stanford Res Inst, Menlo Park, Ca* (1977) 38) W.T. Bolleter, "Recent Improvements in the TNT Manufacturing Process", *Symp on Processing Propriants, Expls & Ingredients, Naval Postgraduate School, Monterey, Ca* (Feb 1977) 39) R. Goldstein, "Recent Developments in the Optimization and Control of Nitration in the Continuous Manufacture of Trinitrotoluene", *Ibid* (Feb 1977) 40) W.M. Stirrat & R.M. Rindner, "Critical Depth Tests of Bulk TNT Flake Explosive", **ARLCD-TR-78003**, USA Arm Res & Dev Command, Dover, NJ (1978) 41) J.R. Murray, "Monitoring and Controlling System for Tetranitromethane Pollutants in TNT Exhaust Gases", *Rept PE-499* (RAD 240.10), Radford AAP, Radford, Va (1978) (Limited distrib) 42) R.A. Mundy & E.E. Gilbert, "Nitroform Recovery and Isolation Studies", *Rept PE-557* (RAD 240.10), *Ibid* (1978) 43) Private communication, Dr E.E. Gilbert with Dr Lingens, Dynamit Nobel AG, Leverkusen, West Ger (no date)

Purification

All crude TNT is purified before military use to remove impurities — mainly the unsymmetrical or "meta" isomers — which lower the mp and cause exudation during storage by the formation of low-melting eutectics. As shown in Table 1 (Ref 21), all the possible TNT isomers are formed during nitration, but only the 2,4,5- and 2,3,4-compds are present in significant quantities

The dinitrotoluenes result from incomplete nitration. The next eight compds listed result, directly or indirectly, from oxidation of the

methyl group during nitration, while the last three are introduced during purification

Prior to WWI, purification was effected by recrystn from an organic solvent, such as ethanol (Ref 4). It was then found that purification could be effected more cheaply, more easily and more safely, with aq Na sulfite ("sellite"), and this has been the standard practice since that time. The meta TNT isomers react with the Na sulfite forming water-soluble sulfonates by the following reaction:

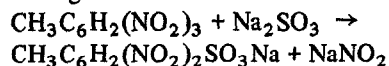

Selliting has been conducted under a variety of conditions (Ref 4). Solns of varying concn have been used with solid TNT, as well as with the liq melt. Batch and continuous processes have been employed

Current American practice entails continuous treatment of molten TNT (> 80°) with an aq soln containing about 0.1 part anhyd Na sulfite per part TNT. This corresponds to about four times the theoretical requirement, according to the equation given above. The liqs are counter-currently contacted in two washers, each of which is followed by a gravity separator (Ref 9). See Fig 1 in the section on "Preparation" for a general view, and Fig 5 for more detail

This purification process is quite sensitive to pH (Ref 23). As shown in Fig 6, yield loss rises sharply above pH 7.5, because of the formation of the water-soluble complex of 2,4,6-TNT with Na sulfite. In addition, at pH values above about 8 (see Fig 7 and Table 1), the formation of two by-products [hexanitrobenzyl (HNBB), and methylpentanitrodiphenylmethane (MPDM)] increases strongly. (The chemical structures and modes of formation of these compds are given in the section on "Chemical Reactions and Derivatives"). These compds have an adverse effect on the mode of crystn of TNT, resulting in the formation of cracks and voids in the finished cast expl (Ref 13). It is also apparent from Table 1 that meta TNT isomers are not completely removed, and that the amounts of all of the DNT isomers and of five of the oxidation products remain unchanged

It was found that to obtain the desired capacity with the two sellite washers of the continuous plant, it was necessary to operate above pH 8, resulting in the adverse effects

Table 1
Impurities Present in TNT Prepared by Continuous Nitration and Purification^a

Compound	Approximate maximum nominal concentration (%) ^b	
	Crude	Finished
2,4,5-Trinitrotoluene	2.50	0.30
2,3,4-Trinitrotoluene	1.75	0.20
2,3,6-Trinitrotoluene	0.50	0.05
2,3,5-Trinitrotoluene ^c	0.05	0.05
2,6-Dinitrotoluene	0.25	0.25
2,4-Dinitrotoluene	0.50	0.50
2,3-Dinitrotoluene	0.05	0.05
2,5-Dinitrotoluene	0.10	0.10
3,4-Dinitrotoluene	0.10	0.10
3,5-Dinitrotoluene	0.01	0.01
1,3-Dinitrobenzene	0.02	0.02
1,3,5-Trinitrobenzene	0.15	0.10
2,4,6-Trinitrobenzyl alcohol	0.25	0.25
2,4,6-Trinitrobenzaldehyde	0.25	0.25
2,4,6-Trinitrobenzoic acid	0.50	0.05
α -Nitrate-2,4,6-trinitrotoluene	0.10	0.10
Tetranitromethane	0.10	none
2,2'-Dicarboxy-3,3',5,5'-tetranitroazoxybenzene ("white compound")	0.35	0.05
2,2',4,4',6,6'-Hexanitrobibenzyl (HNBB)	none	0.40
3-Methyl-2',4,4',6,6'-pentanitrodiphenylmethane (MPDM)	none	0.40
3,3',5,5'-Tetranitroazoxybenzene	none	0.01

a Data from Radford Army Ammunition Plant, Radford, Va

b Concentrations listed are the maximum possible. Actual values will be much lower

c The 3,4,5-isomer has also been identified in crude TNT to the extent of 0.006% (Ref 11)

cited above. It was, therefore, decided to install a third washer to overcome this deficiency. In addition, the gravity separators will be replaced by dynamic separation, thereby greatly reducing the quantity of nitrobody in transit with a corresponding increase in safety

The ROF (British) TNT Process also employs continuous purification, using a compartmented reactor generally similar to that used by them for nitration (see section on "Preparation") (Refs 14 & 15). However, the TNT is contacted as a solid at 67.5°, rather than as a liq at > 80°, as in the American process. This is said to result in a higher yield of purer TNT with a require-

ment of about two-thirds as much Na sulfite. HNBB and MPDM are not formed. Advantage is taken of the fact that the unsymmetrical isomers form a eutectic which migrates to the crystal surface. This type of process is also employed in West Germany (Ref 24). It is operated batchwise, using 4-10p Na₂SO₃ per 100p TNT, and with a reaction time of 30 mins. Use of this purification procedure, taken with a batch trinitration method which removes nearly all of the DNT isomers, yields a TNT of unusually high purity - ie, with a solidification pt of 80.65-80.80°. This type of process has also been used in the past in the USA

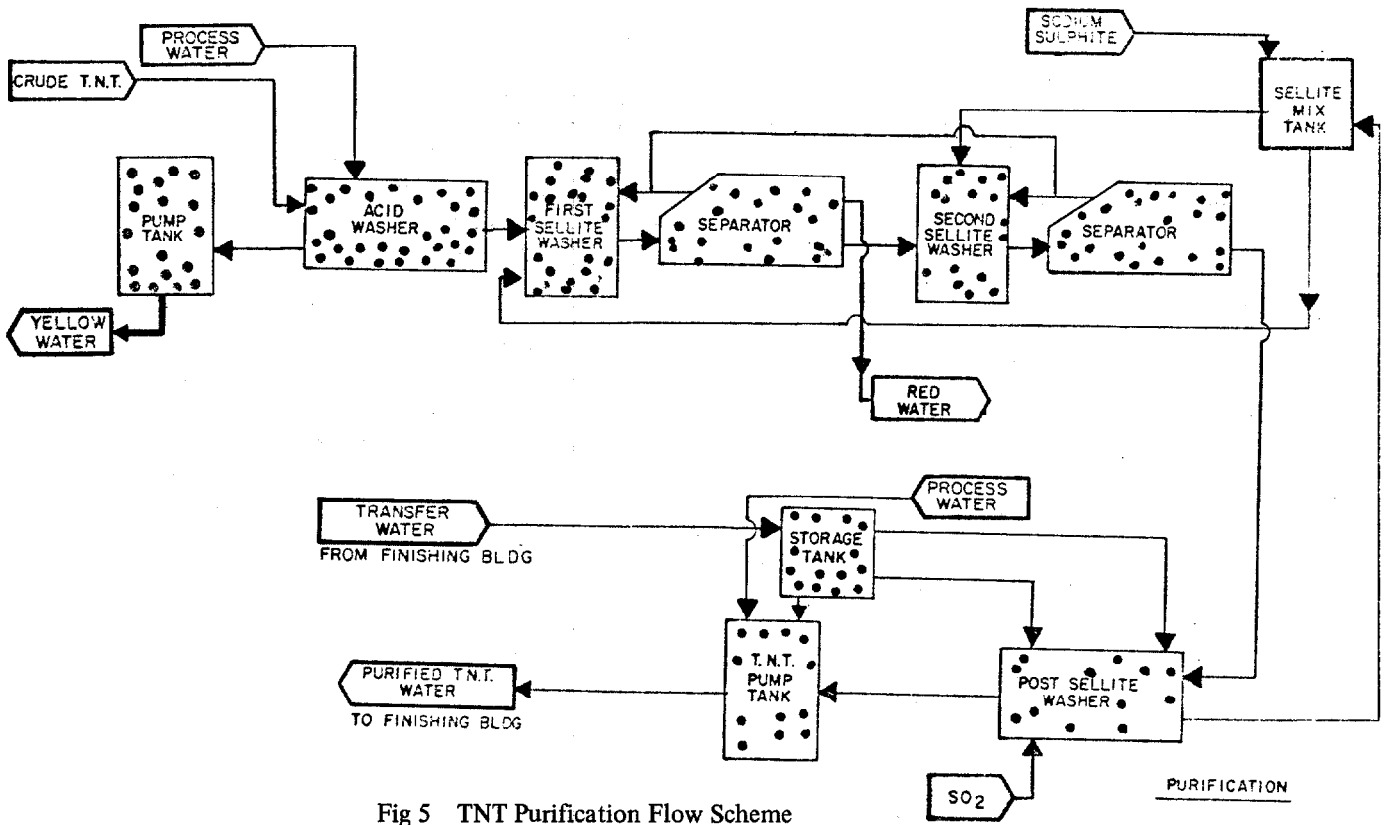

Fig 5 TNT Purification Flow Scheme

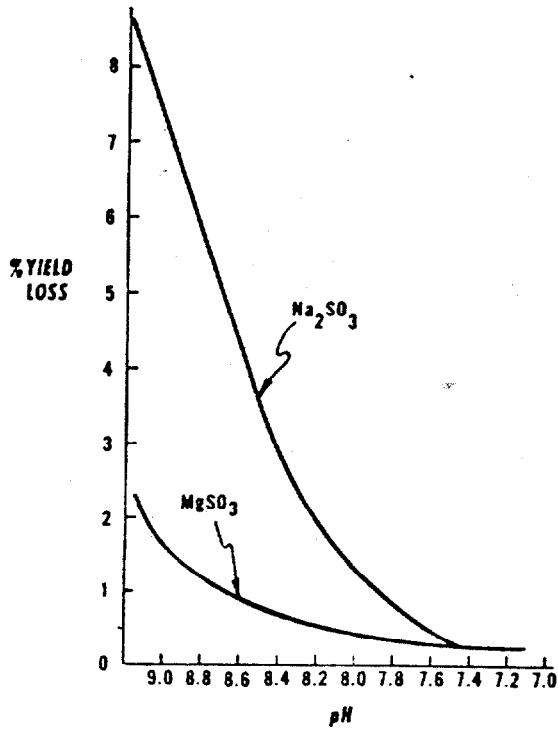

Fig 6 Effect of pH on Heat Loss

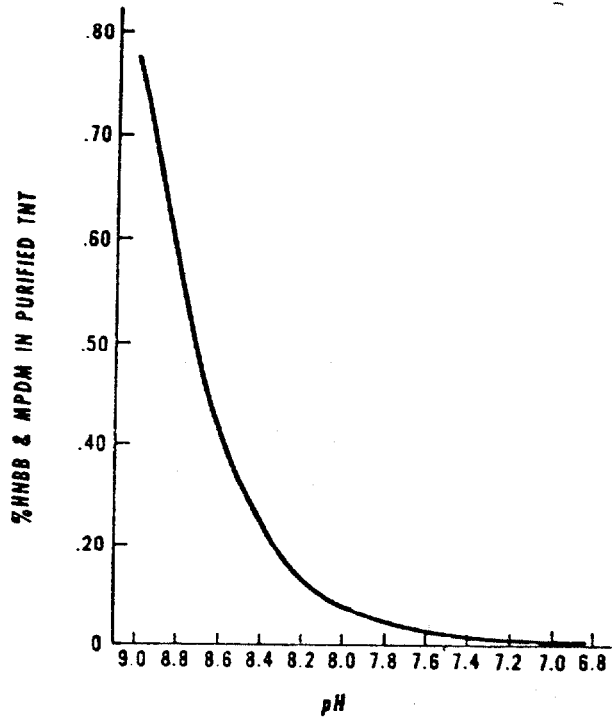
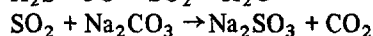
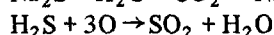
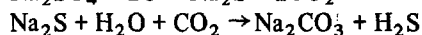
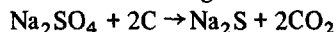
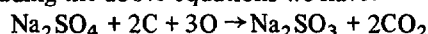

Fig 7 Effect of pH on By-Product Formation

Disposal of the waste sellite soln, known as "red water", is a serious problem. At TNT plants near paper factories, it has been possible to ship the red water to them for process use. For several reasons, this practice is being discontinued. Calcination of the red water gives crude Na sulfate, which has no commercial use. However, it can be reconverted to Na sulfite for reuse in the process by fusion with coal, a procedure in use in the Finnish paper industry. This involves the following reactions:



Adding the above equations we have:



This process is quite energy-intensive and involved chemically. A modification of this procedure involves the addition of Al hydroxide, which desirably eliminates the second step by the formation of H_2S directly in the fusion step; this process is being seriously studied for large-scale recovery of the Na and S values of red water. Lab studies have been made of the composition of red water (Ref 17) and of possible methods for recovery of the organic values of red water (Refs 22 & 25)

Lab studies have shown promise for the purification of TNT with amm and Mg sulfites (Refs 19, 20 & 26). Amm sulfite (Ref 19) removes the meta TNT isomers and yields a product of satisfactory mp. However, some free ammonia is liberated during reaction, and it reacts with the meta TNT isomers forming small amts of dinitrotoluidines. The extent of formation of these compds is determined by the mode of mixing, and with rapid mixing, as in continuous operation, the quantity may be sufficient to give an unsatisfactory mp. The use of amm sulfite has two advantages. It is easily made by mixing S dioxide and ammonia both of which are available at the TNT plant. More importantly, the red water disposal problem is eliminated, since it contains no metallic salts and can be mixed with the TNT spent acid. In the spent acid recovery system, the sulfur values are recovered, and the ammonia values are oxidized to nitrogen

Mg sulfite (Ref 20) gives better yields (see Fig 6) of TNT of higher purity than sellite, and the Mg values are more easily recovered from the red water than are the Na values from spent

sellite. This effected in one step, using one-fourth as much carbon:

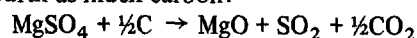

Mg sulfite is less convenient to use, however, since it has lower solubility in w

TNT can also be purified by recrystn from nitric acid (Refs 1 & 2). This process has been used for many years by Bofors AB in Sweden (see Fig in Vol 3, C508). The nitric acid, after crystn and filtration of the 2,4,6-isomer, is recovered by distn, leaving a mixt comprising about 50% 2,4,6-TNT, 25% TNT meta isomers, and 25% dinitrotoluenes and oxidation products, known as "isotrioil" (see Vol 7, I137-L). The isotrioil, which comprises about 10–15% of the crude TNT, has been marketed in Sweden as an ingredient of commercial Dynamite. This process is attractive in that no chemicals are consumed, no serious pollution or disposal problems are involved, the full energy content of the crude TNT is utilized, and the dinitrotoluenes and other impurities are removed from the crude TNT. None of these features are true of the sellite process. In addition, oxidative losses are minimized during nitration, since less drastic conditions are needed when nearly complete removal of the dinitro compds is unnecessary. (With sellite purification, their removal is required by nitration, since this reagent – unlike nitric acid crystn – does not remove the dinitrotoluenes.) In spite of these substantial advantages, the nitric acid crystn process has not been adopted for use elsewhere, since the problem of finding reliable outlets for isotrioil has not proved soluble. (Recently, it has become more difficult to market isotrioil in Sweden)

It has been suggested that complete purification of the TNT is not really necessary in some cases, especially with modern bomb assembly and sealing techniques and the availability of additives to prevent exudation of cast TNT mixts (Ref 6). This proposal merits serious consideration in the light of the problems and energy loss involved in purification as discussed above. The use of low temp during the initial stages of nitration promises to substantially reduce formation of the meta isomers, which will correspondingly facilitate the purification step. This development is discussed under "Preparation". Other refs to TNT purification are cited under "Refs" (Refs 5, 7, 10 & 12)

A lab procedure for purifying small quantities

of TNT has been described (Ref 3), which yields highly purified material suitable for physical measurement studies. This involves the following steps: (1) pptn of an acetone soln of the TNT in w; (2) stirring with 8% Na sulfite soln at 55°; (3) dissolving in hot carbon tetrachloride and washing with hot w; (4) recrystallizing from 95% ethanol; (5) drying over sulfuric acid. This procedure gives a 75% yield of material reported to melt at 81.5°, although others (Ref 18) report a mp of 80.7° using this method. Gas-liq chromatographic analysis shows no detectable impurities (ie, less than 0.01%) (Ref 24)

Refs: 1) J.C.H. Wendes & J.R. Little, "Report on the Known European Processes for the Continuous Production of Trinitrotoluene", Kankakee Unit, Joliet Ars (1954) 2) G.D. Clift & L. Jablansky, "Purification of Crude TNT by the Use of Nitric Acid", PATR 2159 (1955) 3) W.A. Gey et al, "Studies on the Linear Crystallization of TNT Systems", JACS 78, 1803 (1956) 4) Urbański 1 (1964), 376 ff 5) D.H. Rosenblatt et al, "Water Pollution Problems Arising from TNT Manufacture. A Survey", EASP-100-94, Edgewood Ars (1971) (Limited distrib) 6) D.H. Rosenblatt, Paper presented at First Seminar on Nitroaromatic Chemistry, PicArsn (17 March 1971) 7) A.F. Taschler & S.J. Urban, "Evaluation and Comparison of TNT Produced by Continuous and Batch Processes", PATR 4159 (1971) (Limited distrib) 8) E. Thomas, "The ROF TNT Process", Joint US/UK Seminar on TNT Chemistry and Manufacture, Waltham Abbey, Engl (1971) (Limited distrib) 9) W.T. Bolleter, "TNT Process Characterization Studies", Ibid (1971) 10) Anon, Rept ERDE-TR-106, Ibid (1972) (Limited distrib) 11) A. Lonnfors & B. Jansson, ChemEngWorld VII (2), 33 (1972) 12) J.A. Kohlbeck et al, "Final Engineering Report on Continuous TNT Characterization", Study PE-238, Radford AAP (1973) (Restricted distrib) 13) C.D. Chandler, Jr, Paper presented at the 4th Seminar on Nitroaromatic Chemistry, Radford, Va (1973) 14) Anon, "The ROF TNT Process (New Design)", Royal Ordn Factory, Bridgewater, Somerset, Engl (1974) 15) W.T. Bolleter, "Comparison of Processes for Continuous TNT Production", 5th Annual Seminar on Nitroaromatic Chemis-

try, PicArsn (11 Sept 1974) 16) G.R. Gibson & R.L. Dickenson, "Sustained Engineering for the Continuous TNT Process", Final Engrg Rept on Production Engineering Project PE-328, Hercules, Inc, Radford AAP (1975) (Limited distrib) 17) T.N. Hall & W.G. Lawrence, "A Study of the Organic Components of Red Water", NavalSurfWeapCenter, Silver Spring (1976) (AD-A034226) 18) D.K. Philp & B.W. Thorpe, JCrystGrowth 35 (2), 133 (1976) 19) E.E. Gilbert, USP 3956409 (1976) 20) E.E. Gilbert, USP 4003953 (1977) 21) A.T. Nielsen et al, "Reduction and Ammonolysis Products Derived from Isomeric Trinitrotoluenes. Synthesis and Chemical Stability of the Aminodinitrotoluenes", NWC-TP-5933, NavalWeapCenter, China Lake (1977) 22) E.E. Gilbert, Proplnts&Expls 2 (6), 118 (1977) 23) W.T. Bolleter, "Recent Improvements in the TNT Manufacturing Process", Symp on Processing Proplnts, Expls & Ingredients, Naval Postgraduate School, Monterey (Feb 15-17, 1977) 24) R.P. Parker & W.S. Wilson, "Growth of Creamed TNT on Thermal Cycling", MR2-R-720, Dept of Defence, Melbourne, Australia (1978) 25) E.E. Gilbert, "Recovery of Organic Values from TNT Manufacturing Wastes", ARLCD-TR-78012, ARRADCOM, Dover (1978) 26) E.E. Gilbert et al, "New Procedures for Purifying TNT", 1978 Annual Conf, Modern Proplnts & Expls Technol, Karlsruhe, West Ger (14-16 June 1978) 27) Private communication, Dr E.E. Gilbert with Dr Lingens, Dynamit Nobel AG, Leverkusen, West Ger (no date)

Chemical Reactions and Derivatives

Reactions of the Methyl Group

1) Halogenation

Monochlorination can be effected with Na hypochlorite (Ref 32):

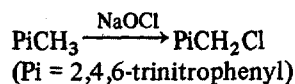

The chloride, prepared in situ, is important as the intermediate for preparing 2,2',4,4',6,6'-hexanitrostilbene (HNS - see Vol 5, D1456-R) (Refs 32, 79 & 87):

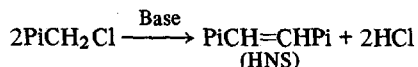

HNS is a thermally-stable expl (Ref 48) and a nucleant for improving the crystn habit of TNT in expl formulations such as Composition B (Ref 52). In the presence of excess TNT, the chloride yields 2,2',4,4',6,6'-hexanitrobibenzyl (HNBB) (see Vol 2, B111-L), which can be oxidized to HNS (Refs 112 & 113):

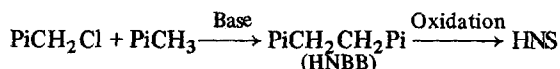

Destructive chlorination to chloropicrin (Cl_3CNO_2) has been noted on warming TNT with Ca hypochlorite (Ref 4). Small amounts of chloropicrin are formed during the above-mentioned prepn of HNS from TNT and Na hypochlorite (Ref 118). On a production scale, an environmental problem is thus created, since this compd is a toxic lachrymator

Heating TNT under pressure at 150–60°, with phosphorus pentachloride and a trace of iodine is said to give a mixt of products, including mainly 2,4,6-trinitrobenzotrithloride and pentachlorobenzyl chloride (Ref 8). Others (Ref 27), however, were unable to prepare the former compd in this way

TNT can be monobrominated with Na hypobromite (Ref 32), or less conveniently by heating under pressure at 160° with bromine and Mg carbonate (Ref 17). Heating TNT with bromine and a trace of iodine under pressure at 200° gives pentabromobenzyl bromide (Ref 3):

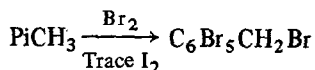

2) Oxidation

The oxidation of TNT can proceed stepwise thru the alcohol and aldehyde to the acid, as follows:

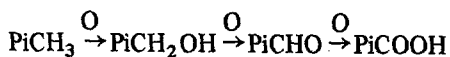

Trinitrobenzoic acid can be prepd by this procedure (see Vol 2, B73-L), but the alcohol and aldehyde are made by other methods, since oxidation cannot usually be stopped at either of these stages, they being more easily oxidized than TNT itself. Trinitrobenzoic acid is easily and quantitatively converted to 1,3,5-trinitrobenzene (TNB – see Vol 2, B48-L), an expl superior in many ways to TNT, but more ex-

pensive to make. Oxidation of TNT is the preferred procedure for preparing TNB. This can be done in 85% yield by heating TNT with 90% nitric acid at 150° under pressure for 18 hours (Ref 63), but the preferred lab procedure involves oxidation with K or Na dichromate in concd sulfuric acid. Yields in this procedure vary from 43–6% (Ref 115) to 86–90% (Refs 15 & 63), apparently depending on minor variations in technique. The addition of acetic acid as co-solvent is said to give a 98% yield of the acid (Ref 81)

Oxidation of the methyl group occurs during TNT manuf, with 2–4% of yield loss occurring in this way (Ref 62). Under certain conditions, the alcohol (as its nitrate) and the aldehyde are thus formed; they react to form 2,2'-dicarboxy-3,3',5,5'-tetranitroazoxybenzene (“white compound”):

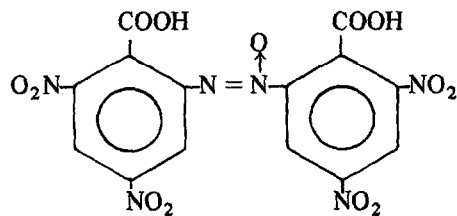
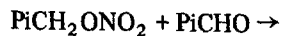

“White Compound”

As noted in the section on “Preparation”, the formation of this material is objectionable, since it coats the equipment piping. By a suitable variation in conditions, this reaction can be minimized, with the alcohol and aldehyde being oxidized preferentially to the acid. Crude TNT contains small amounts of all four of these compds

Trinitrobenzyl alcohol and trinitrobenzaldehyde are also formed, to the extent of about 10% of each, by side reactions during the prepn of HNS from TNT using Na hypochlorite (as mentioned above). They also appear in small amounts during the action of heat or light on TNT

TNT can be oxidized to HNBB, in poor yield, by simply adding base to a soln of it in a suitable solvent (Ref 113):



The nitro groups in a portion of the TNT are the oxidizing agent. Small amounts of HNBB are

formed by this reaction during the purification of TNT with alkaline Na sulfite. Air oxidation in the presence of base and Cu sulfate is claimed to give yields as high as 82% (Ref 91)

3) Reaction with Aldehydes

Formaldehyde reacts with TNT as follows:

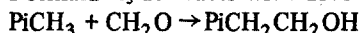

Published procedures (Refs 1 & 28) involve heating with basic aq formaldehyde, in which TNT is poorly soluble. Better results have been obtained by adding acetone as cosolvent (Refs 116 & 117). Other aliphatic aldehydes have apparently not been reacted with TNT

TNT undergoes the Mannich reaction with formaldehyde and various secondary amines (Refs 16 & 40):

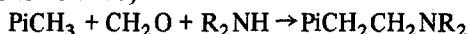

Dioxane was used as solvent and 2% Na hydroxide was added as catalyst; piperazine forms a 1:2 derivative

Benzaldehyde reacts at 1:1 (Ref 12) or 1:2 (Ref 4) molar ratio with TNT:

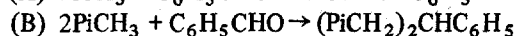

Both reactions are catalyzed by piperidine; reaction (B) is run in pyridine, reaction (A) in aromatic solvents such as benzene or toluene. A series of monosubstituted benzaldehydes react similarly via reaction (A) (Ref 23) as do also terephthalaldehyde (Ref 23), and isophthalaldehyde (Ref 117), both with two moles of TNT. A similar product could not be made from phthalaldehyde (Ref 117), and only traces of HNS were obtained from TNT and 2,4,6-trinitrobenzaldehyde (Ref 31)

4) Reaction with Halides and Unsymmetrical TNT Isomers

In the presence of equivalent K hydroxide, TNT reacts as follows with various halides, such as 4-nitrobenzyl bromide, picryl chloride, or 2,4-dinitrofluorobenzene (Ref 61):

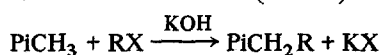

Only compds with highly reactive halogens yield products by this reaction. As the halide reactivity decreases, increasing amounts of HNBB are formed from TNT in the presence of base, as mentioned above

This type of reaction can also occur with compds containing reactive nitro groups (Ref 59). In the manuf of TNT, 2,4,6- and 2,4,5-TNT interact in this manner to form MPDM, as men-

tioned in the section on "Purification":

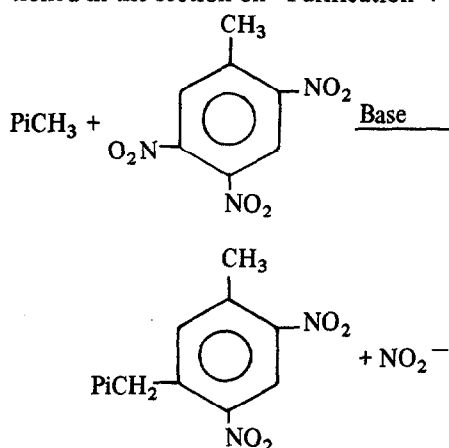

A similar compd can be made from 2,4,6- and 2,3,4-TNT

5) Reaction with Nitroso Compounds

TNT reacts as follows with 4-nitrosodimethylaniline; hydrolysis of the product yields 2,4,6-trinitrobenzaldehyde:

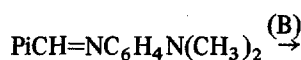
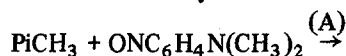

This is the favored procedure for preparing the aldehyde (Refs 11 & 24). Reaction (A) is done at room temp in pyridine, using iodine as catalyst (Ref 11), or in alcohol-acetone mixt with anhyd Na carbonate as catalyst (Ref 24); earlier procedures (see refs cited in Vol 2, B35-R) are reported to be unsatisfactory (Ref 11). Reaction (B) proceeds in strong aq hydrochloric acid; overall yields are 39–52%. Reaction (A) proceeds in 80% yield in aq medium in the presence of light (Ref 90), with less by-product formation than noted in the other methods

Other types of aromatic nitroso compds (eg, nitrosobenzene and -toluene) form nitrones (Ref 4):

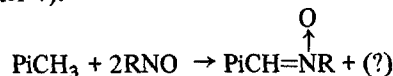

6) Nitration and Nitrosation

TNT undergoes side-chain nitration with alkaline fluorotrinitromethane (Ref 95):

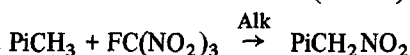

TNT can form several products with nitrosyl chloride in pyridine (Ref 68):

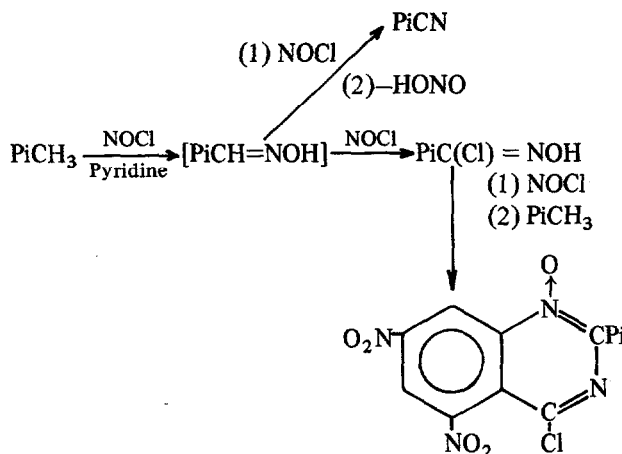

7) Miscellaneous Reactions of the Methyl Group

With N,N-dimethylformamide and phosphorus oxychloride, TNT undergoes the Vilsmeier reaction (Ref 35):

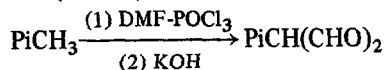

The resulting dialdehyde was converted to derivatives

Phthalic anhydride forms a phthalide derivative (Ref 24):

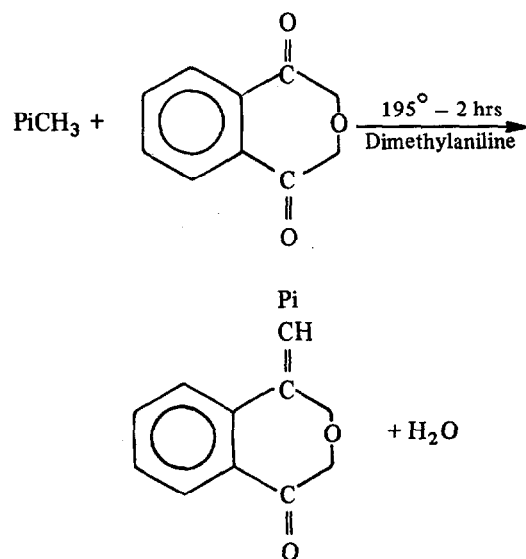

Attempts to repeat this work were unsuccessful (Ref 117)

TNT is said to couple with diazonium compounds (Ref 14), but no details are given. The reaction is presumably:

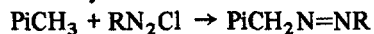

Reactions of the Aromatic Ring

TNT can be monomethylated to trinitro-m-xylene in 9–32% yield by heating with Pb tetraacetate or acetyl peroxide, or by electrolysis with acetic acid-Na acetate (Ref 10). Attempts to introduce more methyl groups were unsuccessful

Reduction of TNT with Na borohydride gives 1-methyl-2,4,6-trinitrocyclohexane (Ref 60) in 21% yield:

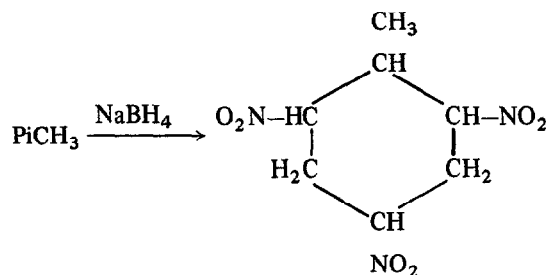

TNT reacts with three moles of diazomethane, forming a product of undisclosed structure (Ref 4). It may resemble the compd obtained from diazomethane and 1,3,5-trinitrobenzene, which has the following 7-membered ring structure (Ref 25):

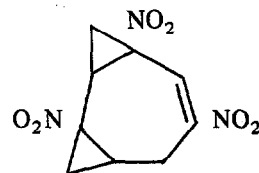

As noted previously, TNT undergoes ring halogenation with loss of the nitro groups at 150–200°, as well as methyl group halogenation

Ring cleavage to chloropicrin occurs with alkaline hypochlorites, as mentioned above. TNT can also be destroyed by treatment with ozone, in the presence of base (Ref 120) or UV light (Ref 89). In both cases, the 2,4,6-trinitrobenzyl anion is generated, which is presumably the reactive species

Reactions of the Nitro Groups

TNT can be reduced to the triamino compound with tin and hydrochloric acid, or with hydrogen using a Pd-BaSO₄ catalyst (Ref 4):

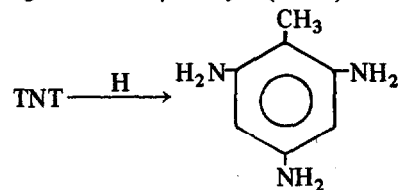

4-Amino-2,6-dinitrotoluene can be made by treating TNT in dioxane with amm sulfide (Refs 4 & 98). A 37% yield of material of 99% purity was obtained (Ref 4). Reaction of TNT with ethyl alc hydrogen sulfide containing a small quantity of ammonia gives a mixt comprising 22% unreacted TNT, 22% 4-amino-2,6-dinitrotoluene, 4% 2-amino-4,6-dinitrotoluene, 44% 4-hydroxylamino-2,6-dinitrotoluene and 8% 2-hydroxylamino-4,6-dinitrotoluene (Ref 4). The 4-hydroxylamino compd can be extracted from the reaction mixt. This procedure has also been used by others (Refs 2, 67 & 69). A report that the 2-hydroxylamino compd could be made by reducing TNT (Ref 4) could not be duplicated (Refs 67 & 69). Reduction of TNT with ethanolic ammonium sulfide gives a good yield of 2,4-diamino-6-nitrotoluene (Refs 9 & 67)

4-Amino-2,6-dinitrotoluene is of interest as the intermediate for one procedure for preparing the thermally-stable, insensitive expl 2,4,6-triaminotrinitrobenzene (TATB) (Ref 119). Tri-nitrophenol glucinol (TNPG, see Vol 8, P248-R), the metallic salts of which have been considered as expl initiators, can also be made from it (Ref 4). The reactions are:

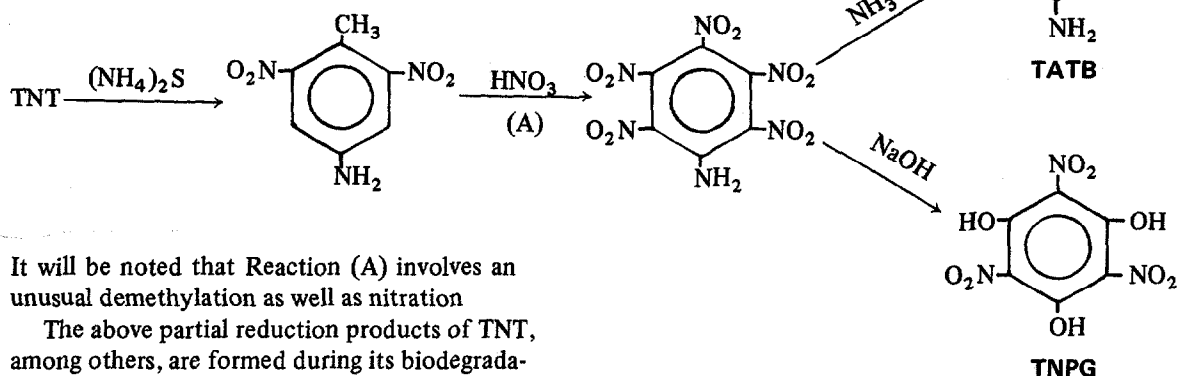

It will be noted that Reaction (A) involves an unusual demethylation as well as nitration

The above partial reduction products of TNT, among others, are formed during its biodegradation, and during the destruction of TNT by reaction with Na or ammonium sulfide (see section below on "Disposal of Waste TNT")

As noted in a preceding section, the aromatic ring can be reduced without reduction of any of the nitro groups

Hydrolytic cleavage of nitro groups, among other reactions, occurs upon exposure of TNT to bases (see "The Action of Bases" below), but TNT, unlike Tetryl or RDX, does not undergo hydrolysis during storage of a satd soln in sea water over a period of several months at 25° in actinic glassware (Ref 66)

Reactions Involving Both the Methyl and Nitro Groups

An important aspect of TNT reactivity involves redox reactions between the reactive methyl group and the nitro groups, a type of reaction which can be initiated by various energetic stimuli, including thermal and photochemical, as well as chemical. In the discussion of these reactions below, it will be seen that they are both intra- and intermolecular, ultimately leading to diverse monomeric and polymeric products. The former type, involving interaction between the methyl and an ortho nitro group, occurs especially easily and is often the first step. It is a very general reaction, applying not only to TNT, but to many other derivatives and analogues of 2-nitrotoluene (Ref 53)

The Action of Bases

All types of nitro compds react easily with bases, forming diverse types of products (Ref 36) In the case of TNT, 2,4,6-trinitrobenzyl anion (I) is formed initially and rapidly. It is a highly reactive species thought to be intermediate in the many reactions of TNT conducted under basic conditions discussed above (Refs 32 & 61). The anion is formed without side reactions by the action of 1,1',3,3'-tetramethylguanidine in dimethylformamide solvent (Ref 106). Based on

spectrophotometric evidence, the first dissociation constant of TNT with NaOH is $1.02 \pm 0.3 \times 10^{-12}$ (Ref 77). It can also be formed photochemically

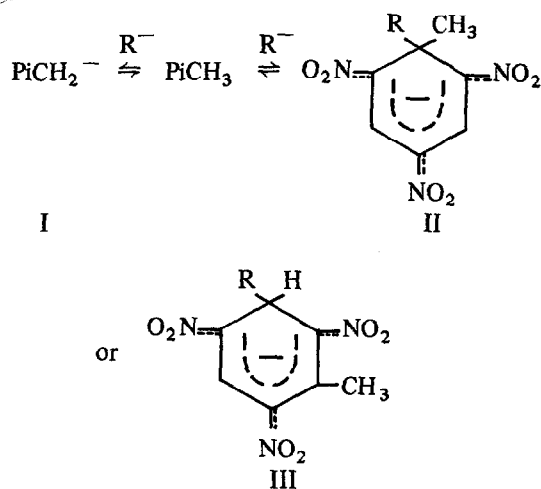

Highly-colored Jackson-Meisenheimer, or σ , complexes of structure II or III are formed by addition to the ring system. The controversial history of the study of these compds has been well reviewed (Refs 44, 46, 51, 70 & 82). They are formed in aq and anhydrous medium, and with a variety of organic and inorganic nucleophiles. Most of these studies have been made with 1,3,5-trinitrobenzene rather than TNT, since the absence of a reactive methyl group in the former simplifies product isolation and identification. The discussion below refers specifically to work done with TNT

Sulfite ion forms a complex of structure III (Refs 44 & 80), which is a source of yield loss during the purification of TNT if the pH exceeds 8. Cyanide ion also forms a compd of structure III (Ref 44); the kinetics of this reaction has been studied (Ref 76). TNT, as the anion I, can react with itself to form adducts of type II; it can similarly react with 1,3,5-trinitrobenzene (Ref 57). Primary and secondary aliphatic amines form σ -complexes (Refs 46 & 58), but tertiary amines (in an aprotic solvent), and aromatic amines, form π -complexes instead. Upon soln in liq ammonia, a complex of type III is initially formed, with no evidence of I (Ref 105). With time, a second NH_2 group becomes attached to the ring carbon with the methyl group; this compd has *cis*- and *trans*-isomers. Removal of the ammonia gave a red

residue comprising about 50% TNT. Acetone carbanion forms a complex of structure III (Refs 44, 46 & 75). Methoxide (Refs 75 & 83), ethoxide (Ref 55), and isopropoxide (Ref 74) form complexes of structure II. *t*-Butoxide ion yields I with TNT and II with PiCD_3 (Ref 73)

In some cases, each mole of TNT can add up to 3 moles of base, as in the case of dilute aq KOH (Ref 82):

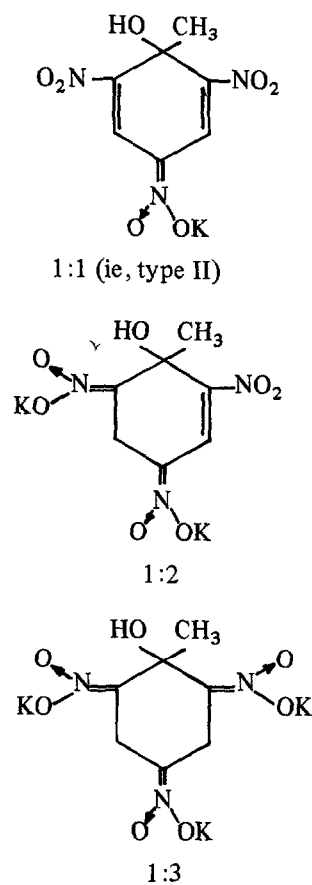

Three moles of K ethoxide can also react (Ref 30); addition of two moles of Na sulfite has been reported (Ref 44)

Side-reactions can occur, especially in the presence of excess base at elevated temps and prolonged times of reaction. K hydroxide (Ref 82) and anhydrous ammonia (Ref 20) can form nitrite ion by cleavage of nitro groups. 2,4,5-Trinitrophenol and 3,5-dinitrophenol have been isolated from the reaction of TNT with NaOH (Ref 77). Redox reactions give polymeric materials via the formation of azo and azoxy groups, as noted with phenylhydrazine (Ref 58):

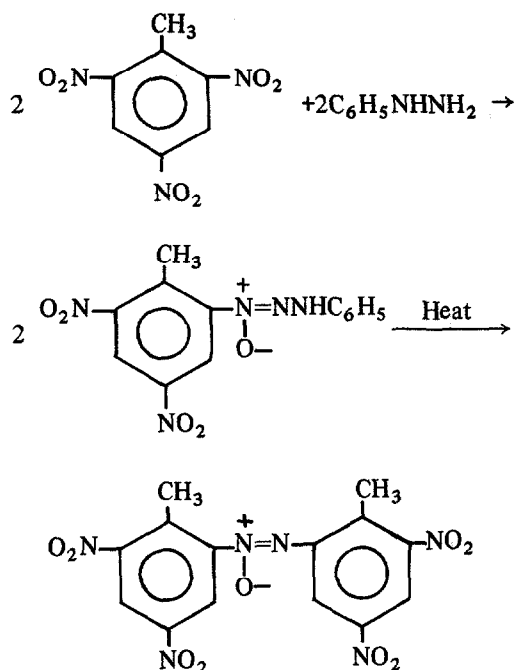

Dimerization also occurs by the redox coupling of two molecules of TNT to form $\text{PiCH}_2\text{CH}_2\text{Pi}$ (Ref 117); the oxidant in this case is TNT. Such reactions are no doubt involved in the formation of complex polymeric materials noted in heating TNT with aq Na carbonate (Ref 13), aq Na hydroxide (Ref 30), or anhydrous ammonia (Ref 20)

The complexes of long-chain primary-secondary aliphatic amines with TNT have low water solubility and may be useful for the removal of TNT from aq solns (Ref 97). The rapid reaction with isopropylamine in acetone has been studied as a possible procedure for the neutralization of TNT in land mines (Ref 88). No products were isolated, but kinetic and thermal data were obtained

The Action of Heat

TNT shows no deterioration after 20 years storage in a magazine, or after two years as a liq at 85° (ie, just above the melting point). TNT vapor was found to undergo no decompn over the range $250\text{--}301^\circ$ at 35 to 500mm Hg pressure (Ref 21); even at 357° TNT vapor does not explode, although decompn is extensive (Ref 18). The thermal decompn of liq TNT is characterized by the sigmoidal curve typical of an autocatalytic reaction. Expln occurs after an induction period which varies with the temp (Ref 18);

at 346° it is 42.5 seconds, and at 430° , 14.5 seconds. Heating 50mg TNT at 328° led to expln in 50 secs. However, at 345° (the boiling point at atm pressure) no expln occurred, since most of the material distilled before sufficient decompn occurred to cause expln. At 150° it is quite stable, even with prolonged heating, but above that temp, it slowly decompn. It generally autoignites after about 38 hrs at 200° (Refs 30 & 47)

The effect of thermal cycling has been studied (Ref 108). Differential Thermal Analysis shows an endotherm at $75\text{--}100^\circ$, and an exotherm at $260\text{--}310^\circ$ (see Fig 8); the Vacuum Stability Test gives a value of $0.1 \text{ (cm}^3/\text{g}/100^\circ\text{C}/48 \text{ hrs)}$ (Ref 114)

The addition of small amts of many diverse materials has been found to accelerate the thermal decompn of TNT. Added nitramines and nitric esters decomp in soln in TNT, and have relatively little effect on the rate of decompn of the TNT (Ref 18), while nitro compds have no effect. Strong promoters of decompn include K nitrate and chloride (Ref 38), certain Fe and Co compds (Ref 18), and ammonia (Ref 18). Other active compds include hydroquinone (Ref 96), benzoic acid (Ref 96), activated carbon (Ref 39), various plastic materials used to seal or line ordnance (Ref 49), and three of the TNT thermal decompn products cited below — namely, trinitrobenzaldehyde (Ref 72), 4,6-dinitroanthranil (Ref 72), and “explosive coke” (Ref 47). Al oxide has a “pronounced” effect, while PbO, Fe, Al, and Fe_2O_3 are less effective in that order, and Sn and CuO have little or no effect (Ref 43). Previous exposure to UV light for several hours also accelerates thermal decompn (Ref 18). The effect of other materials is discussed in limited-access reports (Refs 41, 45 & 50)

A study was made (Ref 47) of the products formed by 10–25% decompn of highly purified TNT, obtained by heating for 26 hours at 200° . It was concluded that the process is quite complex, with at least 25 products being formed. It is highly susceptible to minor variations in procedure and to adventitious catalysis. This led to difficulty in obtaining reproducible results, and even to the reporting of different products by different investigators. A summary of the major products obtained (Ref 47) is as follows:

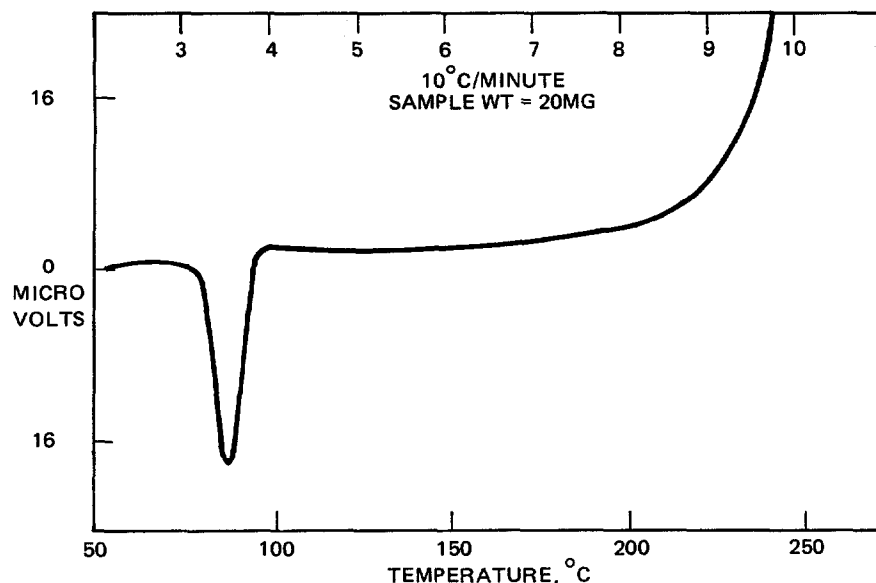
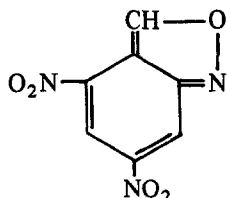

Fig 8 Differential Thermal Analysis—TNT (from Ref 114)

Unreacted TNT, %	75–90
“Explosive Coke”, %	0–13
4,6-Dinitroanthranil, %	2–4
2,4,6-Trinitrobenzaldehyde, %	1–2
Azo and Azoxy Compds, %	0.4
2,4,6-Trinitrobenzyl Alcohol, %	0.2

4,6-Dinitro-anthranil has the following structure:



This type of facile interaction of a methyl with an ortho nitro group has been studied in some detail (Ref 33), most recently (Ref 109) using very low-pressure pyrolysis and laser-powered homogeneous pyrolysis. The latter study indicates surface catalysis

The “explosive coke” is a brown intractable powder, apparently polymeric, melting about 360° and containing nitro groups as indicated by its infrared spectrum. Since similar results were obtained from heating TNT in an inert atm and with exposure to air, oxidation must have occurred at the expense of nitro groups, which would correspondingly be converted to azo or azoxy compds or to an anthranil, by inter- and intramolecular reaction, respectively, with the

methyl groups (Ref 102)

The type of azoxy compd formed is probably as follows:

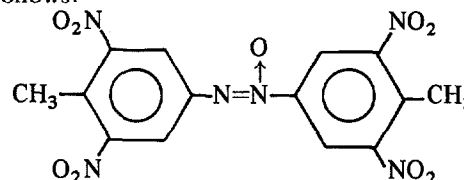

Polymerization and crosslinking by reactions of this type can explain the formation of the “explosive coke”. The compn of the gases evolved was found to vary with the extent of reaction and with the temp (Ref 64). The complicated nature of the process is also shown by the fact that the evolved gases contain not only water, corresponding to the formation of the products cited above, but also CO, N₂, NO, N₂O, and even acetylene (Ref 64)

The first directly-measured evidence that C–H bond rupture in the methyl group is the rate-determining step in the thermal decompn of TNT has been obtained with isothermal differential scanning calorimetric (DSC) analysis using deuterium isotope effects (Ref 96). DSC analysis has also been used to determine the kinetic parameters of thermal decompn (Ref 92). Others (Ref 101) have also studied the mechanism of the reaction using the deuterium isotope effect. Data are available on heat generation in

the range 150–75° (Ref 38), and 50–350° using differential thermal analysis (Ref 37). The decomn of TNT over the range 205–85° has been investigated by electron spin resonance (Ref 107). Confirming earlier work, the process was found to be complex and autocatalytic, with an activation energy of 40.9 ± 1.6 kcal mole⁻¹ for the induction period and 30.2 ± 0.6 kcal mole⁻¹ for the post-induction period. Reactions of the above type are thought to occur during the impact expln of TNT, which is concluded to resemble relatively low-temp thermal decomn, rather than conventional detonation (Ref 104)

The thermal decomn of compds related to TNT has also been examined. Trinitrobenzaldehyde and 4,6-dinitroanthranil, two compds identified as being formed during the decomn of TNT as mentioned above, decompose much more rapidly than TNT (Ref 72). The latter compd is thought to be the autocatalyst in the decomn of TNT (Ref 72). The thermal decomn of trinitrobenzenes containing other alkyl substituents, or NH₂, Cl, F, Br, or OH groups (Refs 54 & 102) has also been studied. In the latter group, the compds containing NH₂ and Cl were the most stable

The Action of Light

Photolysis of aq solns of TNT, such as are obtained as wastes from munition plants, leads to the formation of "pink water". There have been a number of studies made with the ultimate purpose of elucidating the chemistry involved in pink water formation. For general background on the photochemistry of TNT and related nitro compds, see Vol 8, P258-L to P262-L

The nitro group of TNT, in its triplet excited form (³Ar⁺NO₂) induced by the action of UV light, extracts the hydroxyl-hydrogen from certain phenols (Ref 86):

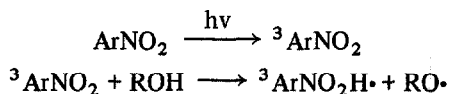

This intermolecular reaction is reversible, and occurs with certain other nitro compds. [Thermal extraction of the hydroxyl-hydrogen of hydroquinone by TNT is cited in the section on "The Action of Heat" (Ref 96)]

Flash photolysis of TNT entails intramolecular hydrogen abstraction from the methyl group

by the ortho nitro group (Ref 78). Triplet TNT (A) is thus converted to *act* TNT (B), identified spectroscopically in non-polar solvents [sequence (1) below]. In polar or basic solvents, (B) undergoes deprotonation to its anion (C), which is in resonance equilibrium with 2,4,6-trinitrobenzyl anion (D), and with its paraquinoid isomer (E) [sequence (2)]:

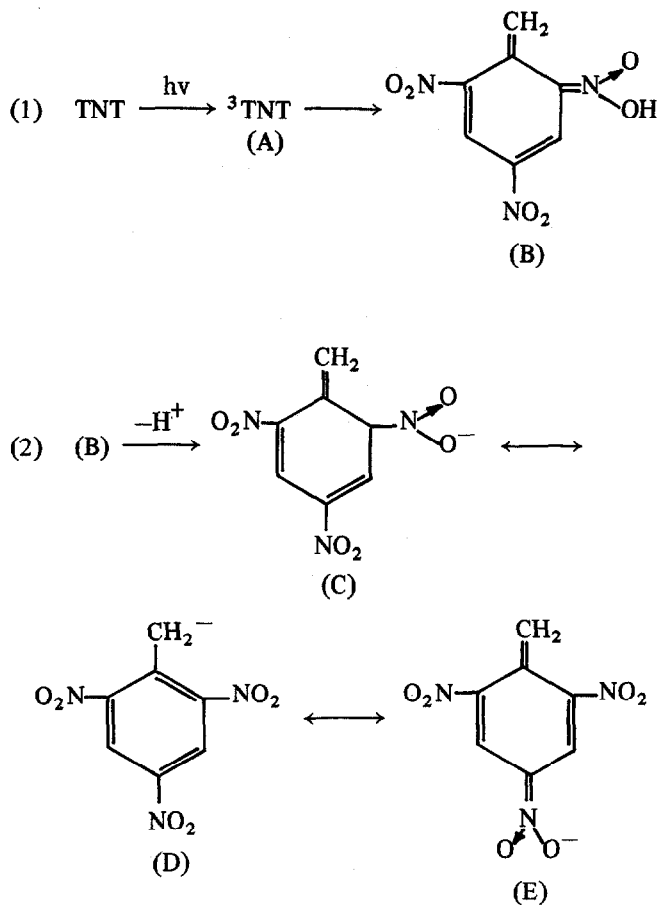

Photoexcitation of TNT at 215° in the gas phase, or at room temp in certain solvents, especially dioxane, leads to the formation of 2,4,6-trinitrobenzyl free radicals (Ref 111)

UV irradiation of aq solns of TNT has yielded a mixt of products, 15 of which have been identified (Ref 85). The methyl group has undergone reaction in all of these compds (to alcohol, aldehyde, carboxyl, or their derivatives). A nitro group has reacted in some cases; this is always *ortho* and never *para* to the methyl group. Reaction of TNT which involve the intermediacy of anion (D), such as the reaction with 4-nitroso-

dimethylaniline, may give better yields when catalyzed by light, rather than by the usual addition of a base (Ref 85). The quantum yield has been measured in aq soln (Ref 100)

Solid TNT also undergoes change on exposure to light (see Vol 7, L14 and under "Radiation Effects" in this Vol); trinitrobenzoic acid has been identified as a product

Data on the photolytic decompn of TNT are available in a limited-access report (Ref 50)

The Action of Electron Impact

The degradation of TNT by electron impact in a mass spectrometer has been studied by the application of the metastable scanning technique (Ref 110). Initial methyl-hydrogen transfer to an adjacent nitro-oxygen is followed by cleavage of the hydroxyl group. The resulting ion then degrades further by several routes, which include the loss of small stable molecules such as CO, NO, HC≡CH, HCN, etc (see article on "Mass Spectrometry", Vol 8, M19-L ff). Mass spectra of all of the TNT isomers have been published (Ref 65). All undergo similar methyl-hydrogen transfer as the first step, except for the 3,4,5-isomer, which lacks adjacent methyl and nitro groups (Refs 65 & 110)

The response of TNT to atomic radiation is discussed under "Radiation Effects" in this Vol

The Action of Activated Carbon

When TNT and activated carbon are dry-mixed at room temp, the TNT displaces the air adsorbed on the carbon rapidly and completely (Ref 39). The carbon has a strong catalytic effect on the thermal decompn of TNT (Ref 39). At 120°, a 90/10 TNT/carbon mixt decompn 12.3 times as fast as pure TNT, and a 50/50 mixt 113 times as fast. This seems logical in the light of the discussion below

Adsorption by activated carbon is commonly employed for the removal of TNT from aq waste streams, eg, "pink water" formed in shell-loading operations. Low efficiency in regeneration of the carbon for reuse has led to a study of the factors involved (Ref 99), with conclusions as follows. The TNT is adsorbed at many of the numerous high-energy sites on the surface of the carbon. Basic materials, introduced during activation of the carbon by combustion and oxidation and also present at these sites, then induce oxidation-reduction reactions of the methyl with the nitro groups in the TNT. This is

manifested in its simplest form by the formation of small amounts of trinitrobenzoic acid and trinitrobenzene. Coupling and polymerization also occur, via generation of azo and azoxy linkages among others, yielding complex high molecular-weight materials which are irreversibly bound to the surface and clog the pores of the carbon. This process is, therefore, generally similar to that involved in the thermal and basic decompn of TNT, as discussed above

Charge-Transfer Complex Formation

TNT forms charge-transfer, or π , complexes with polycyclic aromatic hydrocarbons, aromatic amines, and aromatic nitro compds; a number of these are listed below in Table 2. The complexes with three amines (diphenylamine, diethylaniline, p-anisidine) have characteristic colors; this forms the basis for a rapid and convenient thin-layer chromatographic analytical procedure (Ref 34) for the identification of very small amounts of TNT. (For a discussion of the many color reactions of TNT, and of composite expls containing it, see Vol 3, C405-L ff)

The complexes with nitro compds are quite unstable, as indicated by their low temp of decompn. The presence of small amounts of the HNS complex induces the formation of very fine, randomly-oriented crystals from molten TNT, thereby eliminating the formation of cracks. It is used for this purpose in melt-casting Composition B (Ref 52). 1-Piperidinethiocarboxanilide forms a 1:1 complex (Ref 93)

Based on charge-transfer spectra, the electron affinity of TNT has been estimated at 0.6 eV, relative to 1.35 eV for chloranil (Ref 42)

Table 2
TNT Complexes
With Hydrocarbons

Compound	Molar Ratio (TNT; Cpd)	Ref
Naphthalene	1:1	22, 30, 94
Anthracene	1:1	22, 30
Phenanthrene	1:1	22, 30
Fluorene	1:1	30
Acenaphthene	1:1	30
Hexamethylbenzene	1:1	42, 84

(continued)

Table 2 (continuation)

Compound	Molar Ratio (TNT; Cpd)	Ref
With Aromatic Amines		
Aniline	1:1	30
o- and m-Toluidines	1:1	30
Dimethylaniline, and -toluidine	1:1	30, 71
Diethylaniline	1:1	34
P-Anisidine	—	34
Aminobenzoic acids	1:1	56
Aminostyrene polymers	—	71
2-Haloanilines	1:1;1:2	84
Diphenylamine	2:3	22, 30, 34
α - and β -Naphthylamines	1:1	30
Mono- and dibenzyl- β - naphthylamines	1:1	30
Pyridine	1:1	6
Carbazole	1:1	30
Tetramethyl-p-phenylene- diamine	1:1	42
Benzaldehyde phenyl- hydrazine	2:1	30
1,3,5-Trinitrobenzene	1:1	29
1-Nitronaphthalene	1:1	30
	(64.7°C)*	
2-Iodo-3-nitrotoluene	1:2	22
2,4-Dinitromesitylene	1:1	22
2,4-Dinitroanisole	1:1; 8:1	22
2,4-Dinitrotoluene	1:1	19
	(47.5°C)*	
1,3-Dinitrobenzene	1:1	19
Tetryl	2:1	5, 7, 19
HNS	2:1	103
	(85°C)*	

*Indicates decompn temp

Refs: 1) V. Vender, *GazzChimItal* **45** (II), 97 (1915) & *CA* **10**, 1523 (1915) 2) E. Elvoe, *JIndEngChem* **11**, 863 (1919) 3) S.N. Dhar, *JChemSoc* **1920**, 993 4) Beil **5**, [271] 5) C.A. Taylor & W.H. Rinkenbach, *IEC* **15**, 73 (1923) 6) *Ibid*, *JACS* **45** (1), 44 (1923) 7) *Ibid*, *JACS* **46** (6), 1504 (1924) 8) K.L. Ganguly, *Ber* **58B**, 708 (1925) 9) P. Ruggli & H. Saeslin, *HelvChimActa* **19**, 438 (1936) 10) L.F. Fiest et al, *JACS* **64**, 2052 (1942) 11) W.L. Glen, "Polynitro Compounds Allied to TNT", *Glasgow Rept No* **118** (1942) 12) Davis (1943), 151 13) A.J. Clear, *PATR*

1289 (1943) 14) A.E. Poral-Koshits, *Bull-AcadSciURSS, ClasseSciChim* (1944), 90-92 & *CA* **39**, 1631 (1944) 15) H. Aaronson, *PATR* **1562** (1945) 16) H.A. Brisson & G.B. Butler, *JACS* **68**, 2348 (1946) 17) L.F. Fieser & W. von E. Doering, *JACS* **68**, 2252 (1946) 18) A.J.B. Robertson, *TransFaradSoc* **44**, 977 (1948) 19) O.K. Khaishbasev, *IzvestSektora-FizKhim, Anal, AkadNaukSSSR* **17**, 144-68 (1949) & *CA* **45**, 2762 (1951) 20) F.-M. Lang & J. Boileau, *MP* **34**, 181 (1952) 21) M.A. Cook & M.T. Abegg, *IEC* **48** (6), 1090 (1956) 22) L.A. Burkhardt, *AnalChem* **28** (8), 1271 (1956) 23) W.A. Gey et al, *JACS* **78**, 1803 (1956) 24) M. Blais et al, *PATR* **2524** (1958) 25) T.J. de Boer, *RecTravChim* **79**, 430 (1960) 26) W.E. Batty & I. Dunstan, "Some Properties of TNT Affecting Manufacture and Storage", *Survey No* **2/5/60**, ERDE, Waltham Abbey, Engl (1960) 27) D.N. Gray et al, *JChemSoc* **1960**, 2243 28) Z. Bonecki & T. Urbański, *BullAcadPononSci, SerSciChim* **9** (7), 463 (1961) & *CA* **60**, 2807 (1961) 29) L.A. Burkardt, *JPhysChem* **66**, 1196 (1962) 30) Urbański **1**, 345 ff (1964) 31) K.G. Shipp, *JOrgChem* **29**, 2620 (1964) 32) K.G. Shipp & L.A. Kaplan, *JOrgChem* **31**, 357 (1966) 33) E.K. Fields & S. Meyerson, *JOrgChem* **33**, 4487 (1968) 34) D.B. Parihar et al, *Explosivst* **16** (12), 281 (1968) 35) V.L. Zbarskii et al, *ZhurOrgKhim* **4** (11), 902 (Engl transl) (1968) 36) P. Buck, *AngChemInternatEdit* **8** (2), 120 (1969) 37) A.E. Simchen, *IsrJ-Technol* **7** (6), 445 (1969) & *CA* **72**, 110923 (1969) 38) H.J. Pasman et al, *Explosivst* **17**, 151 (1969) 39) L.C. Smith, *Ibid* **17**, 252 (1969) 40) J.E. Fernandez et al, *JChemSoc (B)*, 506 (1969) 41) T.B. Joyner, "Thermal Decomposition of Explosives. Part 2. Effect of Asphalt on the Decomposition of TNT", *Rept No. NWC-TP-4709*, Part 2, NavalWeapCenter, China Lake (1969) (Limited distrib) 42) R. Foster, "Organic Charge-Transfer Complexes", Academic Press, NY (1969) 43) A.D. Coates et al, "Characteristics of Certain Military Explosives", *BRL Rept* **1507**, Ballistic Res Labs, Aberdeen Prov Grnd (1970) 44) T.N. Hall & C.F. Poranski, Jr, "Polynitroaromatic Addition Compounds", in "The Chemistry of the Nitro and Nitroso Groups", Pt 2, p 329, Interscience, NY (1970) 45) T.B. Joyner, "Thermal De-

- composition of Explosives. Part 5. The Decomposition of TNT in the Presence of Various Substances", Rept No **NWC-TP-4709**, Part 5, NavalWeapCenter, China Lake (1970) (Limited distrib) 46) M.J. Strauss, *ChemRev* **70** (6), 667 (1970) 47) J.C. Dacons et al, *JPhysChem* **74** (16), 3035 (1970) 48) K.G. Shipp, *USP* 3505413 (1970) 49) T.B. Joyner, Rept No **NWC-TP-4709**, Part 8, NavalWeapCenter, China Lake (1971) 50) W.P. Colman & F.C. Rauch, "Studies on Composition B", Final Rept, American Cyanamid Co, Stamford (1971) (Limited distrib) 51) C.F. Bernaseoni, *JOrgChem* **36**, 1671 (1971) 52) J.L. Soderberg et al, *USP* 3620857 (1971) 53) P.N. Preston & G. Tennant, *ChemRev* **72** (6), 627 (1972) 54) Yu.Ya. Maksimov, *ZhFizKhim* **46** (7), 1726 (1972) & *CA* **77**, 125653 (1973) 55) E. Buncel et al, *JACS* **94** (5), 1646 (1972) 56) N.V. Syrmeva, *CA* **84**, 164350 (1974) 57) S.S. Gitis et al, *DoklAkadNaukSSSR* **206** (1), 102 (1972) & *CA* **78**, 3477 (1973) 58) M.J. Strauss et al, *JOrgChem* **37** (20), 3076 (1972) 59) C.D. Chandler et al, *JChromatogr* **67**, 255 (1972) 60) V.A. Sokolova et al, *ZhurOrgKhim(USSR)* **8** (6), 1243 (1972) 61) K.G. Shipp et al, *JOrgChem* **37** (12), 1966 (1972) 62) W.T. Bolleter, Joint US/UK Seminar on TNT Chemistry & Manuf, Tech Rept **106**, Waltham Abbey, Engl (1972) 63) J.C. Dacons, unpublished research data (1972) 64) V.F. Sapronovich et al, *TrMoskKhimTekhnolInst* **75**, 147 (1973) & *CA* **81**, 120125 (1974) 65) T.F. Jenkins et al, *JChemEngData* **18** (4), 438 (1973) 66) J.C. Hoffsommer & J.M. Rosen, *BullEnvironContamToxicol* **10** (2), 78 (1973) 67) M.E. Sitzmann, **NOL-TR-73-70**, NavalOrdnLab, White Oak, Silver Spring (1973) 68) M.E. Sitzmann & J.C. Dacons, *JACS* **38**, 4363 (1973) 69) M.E. Sitzmann, *JChemEngData* **19** (2), 179 (1974) 70) M.J. Strauss, *AcctsChemRes* **7**, 181 (1974) 71) S. Iwatsuki & K. Inukai, *JPolymerSci, A-1*, *PolymerChem* **12** (7), 1437 (1974) 72) Yu.Ya. Maksimov et al, *TrMoskKhim-TekhnolInst* **83**, 51 (1974) & *CA* **85**, 162845 (1974) 73) E. Buncel et al, *CanJChem* **52** (12), 2306 (1974) 74) E. Buncel et al, *ibid* **52** (9), 1750 (1974) 75) A.Ya. Kaminskii et al, *AkadNaukSSSR* (1974) & *CA* **87**, 39042 (1975) 76) L.H. Gan, *CanJChem* **52** (1), 8 (1974) 77) F. Cuta & E. Beranek, *CollectCzechChemCommun* **39** (3), 736 (1974) & *CA* **81**, 2480 (1974) 78) K. Suryanarayanan & C. Capellos, *JChemKinetics* **6**, 89 (1974) 79) T.W. Stull, "A Continuous Process for the Synthesis of Hexanitrostilbene", **MHSMP-75-5F**, Mason & Hanger, Amarillo (Oct-Dec 1974) 80) Yu.N. Polikarpov et al, *TrMoskKhim-TekhnolInst* **86**, 32 (1975) & *CA* **85**, 191776 (1975) 81) M. Haba & A. Hitachi, *JapP* 7448420 (1974) & *CA* **83**, 9523 (1975) 82) V.L. Hammersley, "Historical and Experimental Studies of Alkali and Trinitrotoluene Reaction", **WOEC/C 75-192**, NavalWeapSupCenter, Crane (1975) 83) C.A. Fyfe et al, *JACS* **98** (22), 6983 (1976) 84) A.G. Salina & G.L. Ryzhova, *ZhFizKhim* **50** (1), 231 (1976) & *CA* **84**, 163972 (1976) 85) L.A. Kaplan et al, paper presented at ACS meeting (Sept 1976); & *JOrgChem*, in press (1979) 86) K.A. Muszkat & M. Weinstein, *JChemSoc* **1976**, 1073 87) T.W. Stull, **MHSMP-76-306**, Mason & Hanger, Amarillo (April-June 1976) 88) D.C. Heberlein, "Chemical Neutralization of Trinitrotoluene", Army Mobility Equipment R&D Command, Ft Belvoir (1976) 89) J.D. Zeff, "Purification of Military Waste Waters with Ozone and Ultraviolet", *AnDefPrepAssn 7th Annual Symp on Environmental Res*, Edgewood Ars (Sept 1976) 90) L.A. Kaplan et al, paper presented at ACS mtg (Sept 1976) 91) T. Kampolthy et al, *HungP T/9639, VE-719* (1975) & *CA* **84**, 58886 (1976) 92) J.W. Beckmann et al, *ThermochimActa* **19**, 111 (1977) 93) S. Kannan et al, *MonatshChem* **108** (3), 577 (1977) & *CA* **87**, 101753 (1977) 94) G.L. Ryzhova et al, *Neftekhimiya* **17** (6), 910 (1977) & *CA* **88**, 91917 (1978) 95) M.E. Sitzmann et al, *JOrgChem* **42** (3), 563 (1977) 96) S.A. * Shackelford et al, *JOrgChem* **42**, 4201 (1977) 97) Y. Okamoto et al, "The Removal of 2,4,6-Trinitrotoluene from Aqueous Solution with Surfactants", **ARLCD-TR-77038**, ARRADCOM, Dover, NJ (1977) 98) A.T. Nielsen et al, *CA* **88**, 37347 (1978); (AD 042163) (1977) 99) T.C. Castorina et al, **ARLCD-TR-77065**, ARRADCOM, Dover, NJ (1977) 100) M.A. Ronning et al, *JPhotochem* **9**, 403 (1978) 101) V.G. Matveev et al, *IzoAkadNaukSSSR, SerKhim* (2), 474 (1978) & *CA* **88**, 151803 (1978) 102) Yu.Ya. Maksimov & E.N. Kogut, *ZhFizChim* **52** (6), 1400 (1978) & *CA* **89**,

107565 (1979) 103) M.A. Parry & B. Thorpe, "Nucleation and Growth of TNT Containing HNS", **MRL-R-708**, Materials Res Labs, Ascot Vale, Australia (1978) 104) M.J. Kamlet & H.G. Adolf, *Proplns&Expl* **4**, 30 (1979) 105) J.A. Chudek & R. Foster, *JChemSoc* **1979**, 628 106) A. Jarcewski et al, *CanJChem* **57** (6), 669 (1979) 107) R.M. Guidry & L.P. Davis, *ThermochemActa* **32**, 1 (1979) 108) E. Neal, Jr et al, "Effects of Thermal Cycling on Trinitrotoluene (TNT) and Tritonal Explosive Compositions", **AFATL-TR-79-15**, Rept WQEC/C 79-111 (1979) (Limited distrib) 109) D.F. McMillen et al, "Kinetics and Mechanisms of the Gas-Phase Decomposition of Nitroaromatics", ACS mtg, Honolulu (April 1979) 110) S. Bulusu, *JOrgMassSpec* (in press, 1979) 111) C. Capellos & S. Iyer, *JChemKinetics* (in press, 1979) 112) E.E. Gilbert, *Proplns&Expls* (in press, 1979) 113) *Ibid* (in press, 1979) 114) M.J. Frankel, "Properties of Navy Explosives", **NSWC-TR-147**, Naval Surface Weapons Center, Silver Spring (1980) 115) H.T. Clarke & W.W. Hartman, "Organic Synthesis", *Coll Vol 1*, 541-44 (no date) 116) J.H. Robson, unpublished research data (no date) 117) E.E. Gilbert, unpublished research data (no date) 118) G.F. Hayes, private communication (no date) 119) R.L. Atkins, W.P. Norris & A.T. Nielsen, Pat pending (no date) 120) R.I. Biabets & G.E. Marks, "Ozonolysis of Pink Water", **ITRI-C6275**, IIT Res Inst, Chicago (no date)

Physical and Thermochemical Properties

A tabulation of all the available physical constants of TNT, with refs, was published in 1952 (Ref 23). Included are thermodynamic and crystallographic data, solubilities, and factors affecting chemical stability. Of the 57 properties listed, 28 were selected as most important, and the best values are cited. Another useful compilation of physical properties appeared in 1971 (Ref 43), but with limited refs; a revised edition is scheduled for about 1980. Both of these reports are limited in distribution, as is a data manual published in England (Ref 18). Compilations of physical and other properties appeared in 1972 (Ref 51); this report has unlimited availability

The chemical and physical properties of the

two military grades of TNT are specified (Ref 61) as follows:

Property	General	Special
	Type I	Type II
Solidification point (°C-min)	80.2	80.4
Moisture, % max	0.10	0.10
Acidity (as H ₂ SO ₄), % max	0.02	0.02
Alkalinity	None	None
Insoluble matter, % max	0.05	0.05
Sodium, % max	0.001	0.001
Color	Lt yel	Lt yel thru buff

Physical Properties

Melting Point. Various values have been given for the mp of pure TNT. Some of these are in the range 80.6 to 80.85° (Ref 29). More recent figures are 80.75±0.05° (Ref 30), 80.9 (Refs 28 & 53), 81.0 (Ref 16), and 81.5° (Ref 25). The last figure was obtained with highly purified material, using the procedure detailed under "Purification". Others (Ref 59), however, report a mp of 80.7° on material purified by this method. Cooling curve data, using nearly pure TNT, indicate a mp of 80.9° for pure TNT (Ref 65). Military grade TNT is specified to have solidification temps indicated in the table above, depending upon the type. (The solidification point, also termed "freezing point", or "setting point", is considered more reproducible than a mp (see Vol 6, F188-L)

Vapor Pressure. The vapor pressure of solid TNT has been determined over the range 12 to 56° by two groups using a new gas chromatographic technique with an electron-capture detector (Refs 64 & 65). This procedure is simple, sensitive, and purifies the sample in situ. The equations obtained are as follows:

$$\log_{10}P = 12.31 \pm 0.34 - (5175 \pm 105) / T \quad (\text{Ref 64})$$

$$\log_{10}P = 19.2533 - 7371.46 / T \quad (\text{Ref 65})$$

Excellent agreement was obtained with several earlier measurements using the Knudson effusion technique (Ref 65). The vapor pressure of liq TNT has been measured up to 143° with the Knudsen procedure (Ref 19); the following equation was obtained:

$$\log_{10}P = 10.90 - 4960 / T$$

A radioactive tracer method has also been used

to measure the vapor pressure of TNT (Ref 44)

TNT boils at 345° at atm pressure. Small amounts (<50mgs) can be distilled rapidly at atm pressure without expln (Ref 13); expln does occur with the longer heating periods required to distill larger quantities. TNT distills at 210–12° at 10–12 Torr (Ref 29). The boiling point of TNT has also been determined by differential thermal analysis (Ref 57)

Density. The crystal density of TNT, by flotation, is 1.654g/ml (Ref 16). The density of cast TNT has been determined as 1.648g/ml by a new gas comparison pycnometer technique (Ref 62); 1.55 (Ref 30) and 1.59 (Vol 7, L51) were cited earlier. The theoretical max density is 1.654g/ml (Ref 62). Densities as high as 1.64 have been reported for pressed TNT (Ref 51); a range of 1.34 to 1.55 – depending on pressure – is given in Vol 7, L51. The density changes of TNT have been measured from –196° to +67° (Refs 52 & 60)

The densities of air-saturated liq TNT are as follows (Ref 25):

Temp, °C	Density, g/ml
72.3	1.4718
79.2	1.4652
86.2	1.4588
92.4	1.4528

The following equation was found to represent the density of liq TNT over the range 82–90° (Ref 22), regardless of the degree of saturation with air:

$$d(\text{g/ml}) = 1.4616 - [0.001] [t(^{\circ}\text{C}) - 82]$$

A more recent equation (Ref 28) covers the range 83–120°:

$$d(\text{g/ml}) = 1.5446 - 1.016 \times 10^{-3} t(^{\circ}\text{C})$$

At 85°, this equation gives a density of 1.4583; literature values range from 1.4579 to 1.4591

Viscosity. The viscosity of TNT has been measured from 72.3 to 92.4° (Ref 25); at 100°, it is 9.5cP (Ref 30)

Refractive Index. TNT has index of refraction values of $\alpha = 1.543$, $\beta = 1.674$, $\gamma = 1.717$ (Ref 16). They indicate a hardness of 1.4 on the Mohs scale. The observed molecular refraction is 49.6 vs 44.3 calcd (Ref 16)

Surface Tension. The following values have been reported (Ref 24):

Temp, °C	Dynes/cm
80	47.07
85	46.63
87.6	46.36
90	46.04
95	45.62

Another investigator reports 46.72 dynes/cm at 81° (Ref 25). A study has been made (Ref 71) of the interfacial tension between waxes and TNT, and its reduction by adding long-chain esters of 2,4,6-trinitrobenzoic acid

Modulus of Elasticity. Young's modulus for TNT is 5.4×10^{10} dynes/cm² (Ref 30)

Compressive Strength. Cast TNT, density 1.62g/ml, has a compressive strength of 1380–1400 lbs/in² (Ref 30)

Dielectric Constant. The dielectric constant of TNT has been measured at 35GHz over the density range 0.9 to 1.7g/ml (Ref 27). Representative data are as follows:

Density, g/ml	Crystals	Ground Flake
0.9	2.048	2.092
1.2	2.347	2.362
1.5	2.795	2.773
1.7	3.178	3.125

Other data are also available (Refs 42 & 54)

Eutectic Formation. TNT forms binary and ternary eutectics with various types of nitro compds and nitrate esters. Many of these are listed by Urbański (Ref 29); others have been reported more recently (Ref 25). Since the di-nitrotoluenes and the unsymmetrical TNT isomers form such eutectics with 2,4,6-TNT which melt just above room temp, their removal is necessary to prevent exudation from TNT-based expls. One procedure for purifying TNT takes advantage of the fact that the eutectic containing the undesired isomers migrates to the crystal surface (see discussion under "Exudation" and "Purification")

Solubilities. TNT is slightly soluble in water (0.011, 0.012, and 0.147g/100g water at 0°, 20°, and 100°)(Ref 4). Its hygroscopicity is "practically nil", ie, ca 0.05% (Ref 1). Although TNT is nonhygroscopic, the presence of moisture lowers its freezing point, as shown by the following data (Ref 10):

Freezing pt (°C)	Wt % water
80.59	0
80.35	0.1
80.20	0.2
79.99	0.3
79.78	0.5
79.09	1.0
77.93	2.5

Removal of the water by heating at 100° is slow, as shown below (Ref 10), starting with a sample containing 0.3%:

Freezing pt (°C)	Hours
79.99	0
80.30	2
80.46	3.5
80.55	5
80.59	6

TNT is somewhat soluble in 70–100% sulfuric acid (Ref 29), and is very soluble in liq sulfur trioxide (Ref 76) and in 78–97% nitric acid (Ref 29). Solns in concd nitric acid are sensitive Sprengel-type expls and should be handled with care (Ref 12)

Solubility data for three organic solvents are as follows (Ref 47) (25°, g/100g solvent): N,N-dimethylformamide, 142; dimethyl sulfoxide, 128; 1-methyl-2-pyrrolidinone, 118. Solubility in the first solvent is 90 and 119g/100g solvent at 0 and 15°, respectively. TNT is very soluble at room temp in tetrahydrofuran and in hexamethylphosphoramide (Ref 76). Solubilities in other solvents have been measured in the range 0–100° (Refs 4 & 30); the data for 20° are given below (g TNT/100g solvent):

Pyridine	137
Acetone	109
Methyl acetate	72.1
Benzene	67
Toluene	55
Chlorobenzene	33.9
Chloroform	19
1,2-Dichloroethane	18.7
Diethyl ether	3.29
Trichloroethylene	3.04
95% Ethanol	1.23
Carbon tetrachloride	0.65
Carbon disulfide	0.48

The solubility of TNT in methanol is 9.5 and 31.6g/100g solvent at 40 and 60° (Ref 76)

The absorption of air by molten TNT is constant at 3.22ml/100g TNT over the range 82 to 95° (Ref 22)

Thermochemical Properties

Selected heat effect data (heats of formation, detonation, fusion, vaporization, and sublimation, heat conductivity coefficients and specific heats) for TNT and other common expls are given in Vol 7, H36-R to H46. Additional thermochemical data, up to about 1972, have been conveniently summarized (Ref 51). The data given below include some items which are more recent or less easily accessible

Specific Heat. Specific heat data are available over a wide temp range (Refs 6 & 55). The values at 0, 40 and 80° are 0.309, 0.345 and 0.374cal/g/°C, respectively (Ref 6). Rouse (Ref 56) quotes a value of 0.25cal/deg/g; Lenchitz and coworkers (Ref 41) have measured it from 10 to 300°K. Some of these data (see footnote in Ref 41) are tabulated below. The specific heat at constant volume has been measured (Ref 31), and found to be ca 30% less than that at constant pressure

Heat of Combustion. Recent values for $-\Delta H_c^\circ$ /mole (for the crystal) are 809.90 ± 0.72 (Ref 41), and 817.2 (Ref 56). The best earlier value is 813.11 ± 0.81 (Ref 35)

Heat and Free Energy of Formation. The heat of formation, $-\Delta H_f^\circ$ (for the liq or crystal), is reported as 15.1 ± 1.2kcal/mole (Ref 56) and 19.25 ± 0.74 (Ref 41). The selected value from earlier data is 16.03 ± 0.65 (Ref 35). $-\Delta H_f^\circ$ (for the gas) is 1.76 (Ref 41). The free energy of formation, ΔG_f° (for the crystal) is 50.92 ± 0.83 (Ref 41)

Heat of Fusion. Extrapolation of enthalpy curves gives the heat of fusion as 23.53cal/g (Ref 28). Cady and Rogers (Ref 28) quote earlier literature data, which we summarize as follows:

Method	Heat of Fusion (cal/g)
Calorimetric	22.1
Cryoscopic	20.2, 21.7, 22.1
Vapor press-temp data	23.8, 25.2
(Not given)	21.41, 22.3

Table 3
Specific Heat, Heat Content (Enthalpy), and Entropy Data
10–300° K (from footnote, Ref 41)

Temp, °K	Specific Heat (J/mole/°K)	Heat Content (Enthalpy) (J/mole)	Entropy (J/mole/°K)
10	3.116	10.390	1.732
30	32.71	352.77	17.49
50	60.41	1293.0	40.90
70	82.52	2731.0	64.89
90	101.70	4576.7	87.98
110	118.76	6784.8	110.08
130	133.54	9309.6	131.13
150	148.30	12128	151.28
170	162.84	15240	170.73
190	177.15	18640	189.63
210	191.24	22325	208.05
230	205.09	26288	226.07
250	218.72	30527	243.74
270	232.12	35036	261.08
300	251.80	42296	286.56

Heat, Free Energy and Entropy of Sublimation. Values for the heat (enthalpy) of sublimation are tabulated below:

Heat of Sublimation (Kcal/mole)	Ref
25.0 ± 0.4	41
28.3	19
24.4	21
33.7	63
23.7 ± 0.5	64
24.7 ± 0.6	34

Gibbs free energy of sublimation is 69.6 ± 3.0 kJ/mole (Ref 70), and the standard entropy of sublimation is 146.2 ± 1.3 J/mole/°K (Ref 70)

Heat of Vaporization. Values reported for this constant are listed below:

Heat of Vaporization (Kcal/mole)	Ref
17	7
17.5	14
22.7	19
18.4	Vol 7, H44 (Table 3)

It has also been measured more recently by differential thermal analysis (Ref 57)

Thermal Conductivity. The following data are reported:

Thermal Conductivity (cal/cm/sec/°C × 10 ⁻⁴)	Density (g/cm ³)	Ref
3.5	0.846 (powder)	8
3.8	1.62 (cast)	2
4.8	1.56 (cast)	8
6.22	1.60	51
5.3	1.19	Vol 7, H46 (Table 4)
7.1	1.51	Vol 7, H46 (Table 4)
4.8	1.6	Vol 7, H46 (Table 4)

Entropy. Entropy data is given above for the range 10–300°K. The standard entropy for the crystal is 68.12 ± 0.38 cal/K/mole (Ref 41)

Enthalpy. The enthalpy of TNT, relative to 0°C, is expressed as follows over the range 25 to 68° and 83–117°C (Ref 28) (T expressed as degrees C):

$$H-H_0(\text{cal/g, } 25^\circ \text{ to } 68^\circ) = 0.045 + 0.24625T + (4.205 \times 10^{-4})T^2$$

$$H-H_0(\text{cal/g, } 83^\circ \text{ to } 117^\circ) = 12.450 + 0.45023T - (4.0091 \times 10^{-4})T^2$$

The standard enthalpy is 113.2 ± 1.5 kJ/mole (Ref 70). Earlier values (Ref 70) are 101.8, 118.1 and 122–132 kJ/mole. Enthalpy (heat content) data over the range 10–300°K are given in a table

Thermal Diffusivity. The following data are available (Ref 3):

Thermal Diffusivity ($\text{cm}^2/\text{sec} \times 10^4$ at 25°C)	Density (g/cc)
19.7	0.64
15.0	0.783
12.1	0.980

Coefficient of Linear Thermal Expansion. The following values have been reported (Ref 7):

Coefficient ($\text{in}/\text{in}/^\circ\text{C} \times 10^{-4}$)	Temp (°C)
0.7	15–66
2.0	19–69
2.1	15–69
2.63	16–70
3.8	15–65

Later studies are in agreement (Ref 11)

Data have been obtained for the three crystallographic axes of TNT, as follows (10^{-5} , per °C):

			Refs
4.96	5.05	18.1	40
5.16	5.56	15.36	69
5.0	5.0	20.0	20

There is disagreement over the assignment of these values to specific axes (Ref 69). Thermal shock occurs along the short axis (Ref 20)

Crystallization Data

Knowledge of the mode of crystn of TNT is essential because it underlies the widespread practice of melt-pouring employed in the preparation of the commonly-used composite expls, such as Composition B. Samples of TNT obtained by sublimation onto a condensing surface held at a temp (78°) close to the mp, or by freezing melts at temps close to the mp, consist solely of the simple monoclinic form (Ref 26). Crystn from solvents at room temp, or from strongly supercooled melts, yields primarily monoclinic variant forms. Orthorhombic TNT is formed by crystn from solvents at low temps. At least seven morphological types of TNT have been identified (Ref 48). Two types have been identified by nuclear quadripole resonance (NQR) (Ref 66); a phase transition was noted at

approx 200°K. Unusual crystal growth occurring when TNT crystals are held at temps near their mp has been attributed to the formation of three polymorphs (Ref 37); others, however, attribute this phenomenon to lattice strain rather than to polymorph formation (Ref 36). "Premelting" has been noted at 75.7° (Ref 28). At -15° molten TNT forms a glass (Refs 32, 33 & 39)

Additives can affect the crystn process profoundly. The addition of picryl chloride induces formation of the orthorhombic form (Ref 26). Other picryl derivatives, especially 2,4,6-trinitrostilbene and related compds, drastically reduce the linear crystn rate (Ref 25). Two compds introduced in small amounts during the purification of TNT – hexanitrobenzyl (HNBB) and methylpentanitrodiphenylmethane (MPDM) – have the same effect, which may adversely affect subsequent melt-loading operations. A TNT-hexanitrostilbene complex, as discussed below, induces monoclinic crystn while strongly inhibiting supercooling. It is evident that TNT crystn behavior is complex and highly responsive to specific conditions

Procedures have been described for the preparation of TNT of a range of particle sizes and shapes by various methods including ball milling, slow cooling with or without stirring, quick cooling in ice, and the addition of a hot soln to a cold diluent, or to dry ice with stirring (Ref 17). A simple solvent crystn procedure for preparing large single crystals has been described (Ref 49). Stain-free, thin, single-crystal platelets can be grown by vacuum sublimation (Ref 48) with argon as the ambient gas; the conditions used are quite critical, however

During solidification, molten TNT undergoes ca 11% shrinkage in volume (causing cracking) (Refs 11, 22 & 58), and tends to form some large orthorhombic crystals with intergranular voids. Since cracks and voids are objectionable in cast expls, such as Composition B, means for eliminating them have been sought. This appears to involve a procedure for overcoming the strong tendency of molten TNT to supercool, with subsequent slow initial crystn at the melt surface, resulting from an insufficiency of crystal nuclei. Addition of solid "seed" TNT, with stirring, to the melt yields a "smooth" casting with the desired very fine, randomly-oriented monoclinic crystals, a result in agreement with lab data

noted above. The requirement of this "creaming" process for fine temp control and the high viscosity of the mixt, have, however, resulted in a search for more practical methods (Ref 59)

The most promising procedure involves the addition of a small amount (<2%) of Hexanitrostilbene (HNS — see Vol 5, D1456-R & Ref 46), which minimizes supercooling, induces formation largely of monoclinic crystals and gives fine casts (Refs 59 & 72). For the HNS to be effective, a "double thermal cycling" procedure was at first thought necessary; it induces the formation of the active material, a 1:2 molar complex of HNS to TNT (Refs 46, 59, 72 & 77). Later work (Ref 73) has shown that dispersed, uncomplexed HNS is equally effective, and that the double thermal cycle is not required, nor is dissolution of the HNS. TNT surveillance test samples containing 0.5% HNS were submitted to thermal cycling (Ref 74). They showed increased exudation, irreversible crystal growth, decreasing density, and eventually complete crumbling (thermal cycling of TNT not containing HNS is discussed below). The addition of a small amount of a polycyclic aromatic hydrocarbon, eg, anthracene, is said to inhibit cracking (Ref 38); other attempts to prevent cracking with additives are discussed in Vol 1, A461-R to A462-R. Thermal cycling tests using 1-nitronaphthalene have given poor results (Ref 74)

There have been two noteworthy studies of TNT crystn made to obtain a better understanding of the factors involved in melt-casting. The first study, reported in 1952 (Ref 22), identified four possible causes for cavitation in the finished cast: (1) mechanically entrapped air; (2) dissolved air, measured at 3.22ml per 100g TNT, which is evolved during crystn; (3) shrinkage during solidification of the melt, amounting to about 10% of the original volume of the melt; (4) shrinkage of the solid TNT in cooling from the mp to room temp. Cavitation from the first two causes could be avoided by using vacuum melt kettles to prepare air-free TNT, and from the third by adding molten TNT to compensate for the corresponding shrinkage. No remedy was seen for the fourth cause of cavitation. Linear crystn velocity data was obtained over the range 40–80°, and it was concluded that the lower the temp, the higher was the velocity of crystn and the smaller was the

size of the crystals. The authors consider many possible methods for accelerating the solidification rate of TNT at the center of large shells, where the insulation of the solid outer layer of TNT is so effective that a gram of TNT at the center solidifies at 1% or less of the rate of the outer layer of liq. The most promising approach is concluded to involve the use of a slurry of solid TNT in the melt. This study was made before it was known that additives can strongly affect the mode of crystn

The second study (Ref 58), published in 1976, likewise noted a 10–11% shrinkage upon solidification, and studied the solubility of various gases in the melt, as well as the rate of solidification of the supercooled liq at various rates of heat removal and at various temps. The role of nucleating agents was discussed, and HNS was shown to be effective. The established physical principles of solidification were found fully applicable to TNT

The results have been reported (Ref 69) of an interesting study of the thermal cycling of creamed TNT. Irreversible thermal expansion ("growth") occurs with a corresponding reduction of density. It increases linearly with the maximum temp attained in a manner which suggests the existence of a critical upper temp which must be exceeded for any growth to occur. This temp (30–35°) is close to the eutectic temp (36.5°) observed for a ternary mixt of 2,4,6-TNT, 2,3,4-TNT and 2,4-DNT

Growth correlates with the quantity of impurities present, as shown by the following data, resulting from 40 6-hour cycles between 4 and 58°:

Impurities Present	Percent Growth
None	0
2,4-DNT–0.13%; 2,3,4-TNT–0.03%	0.51
2,4-DNT–0.20%; 2,3,4-TNT–0.03%	1.01

Changes in the surface of the TNT were also noted during thermal cycling, in that crystals appeared on an originally smooth surface, and the grain boundaries of adjacent crystals were redistributed

A "ratchet" mechanism is proposed to account for growth, in which the stresses generated by anisotropic thermal expansion of TNT are

relieved above the eutectic temp by a mass transfer process such as grain boundary sliding or dynamic recrystn (see above for ref to a study of the thermal cycling of TNT-HNS mixts)

Limited-access reports on TNT crystn (Refs 45 & 67) are cited in the Refs which follow

- Refs: 1) W.J. Huff, *ChemMetEng* **21**, 570 (1919)
 2) W.E. Garner & C.L. Abernathy, *ProcRoySoc* **99A**, 213 (1921) 3) A.M. Prentiss, *ArmyOrdn* **4** (20), 117 (1923) 4) C.A. Taylor & W.H. Rinkenbach, *JACS* **45** (1), 44 (1923) 5) A.M. Prentiss, *ArmyOrdn* **4** (22), 242 (1924)
 6) C.A. Taylor & W.H. Rinkenbach, *JACS* **46** (6), 1504 (1924) 7) M.I. Mantrov, *JChemInd (Moscow)* **6**, 1686 (1929) 8) A.F. Belyaev & N. Matyushko, *CompRendAcadSciUSSR* **30** (7), 629 (1941) 9) H. Muraour, *Protar* **9**, 62 (1943)
 10) B.T. Fedoroff, unpublished research data (1944) 11) A.J. Clear, *PATR* **1547** (1945)
 12) C.H. Brooks et al, "TNT Manufacture and Development Work in Germany", **PB 22930** (1945) (available NTIS) 13) A.J.B. Robertson, *TransFaradSoc* **44**, 977 (1948) 14) *Ibid* **44**, 997 (1948) 15) A.F. Belyaev, *JPhysChem (USSR)* **22**, 91 (1948) 16) W.C. McCrone, *AnalChem* **21**, 1583 (1949) 17) G.A. Cave et al, *IEC* **41**, 1286 (1949) 18) W.H. Rinkenbach, *JACS* **52**, 116 (1950) 19) G. Edwards, *TransFaradSoc* **46**, 423 (1950) 20) W.R. Eubank & R.W. VanDolah, "Thermal Studies on TNT", **NOTS 316**, Naval Ordn Test Sta, China Lake (1950) 21) I. Nitta et al, *Nippon-KagakuZasshi* **71**, 378 (1950) & *CA* **45**, 6448 (1951) 22) Anon, "Casting of TNT", *Armour Res Foundation*, Final Rept (June 1952)
 23) Anon, "Supplement to Final Report for Project No 90-1138C", *Armour Res Inst, Illinois Inst of Technol*, Contract No DA-11-173-ORD-160 (1952) (Limited distrib) 24) D.T. Lewis, *JApplChem(London)* **3**, 154-60 (1953) & *CA* **47**, 7217 (1953) 25) W.A. Gey et al, *JACS* **78**, 1803 (1956) 26) L.A. Burkardt, *AnalChem* **28** (8), 1277 (1956) 27) G.F. Cawsey et al, *ProcRoySoc(London)* **248A**, 499 (1958)
 28) H.H. Cady & W.H. Rogers, **LA-2696**, *US AtomEnerComm* (1962) & *CA* **57**, 10089 (1962) 29) Urbański **1**, 291 ff (1964)
 30) W.H. Rinkenbach, in *Kirk & Othmer's Encycl of Chem Technol* **8**, 611 (1965)
 31) B.O. Reese et al, *West States Sect, Combstn Inst Paper WSS/CI 68-39* (1968) & *CA* **72**, 104688 (1969) 32) F.G.J. May et al, *JCrystal Growth* **5**, 312 (1969) 33) W. Connick et al, "Polymorphism in 2,4,6-Trinitrotoluene", *AustralianJChem* **22**, 2685 (1969) 34) C. Lenchitz & R.W. Velicky, *JChemEngData* **1970**, 15 (3), 401 35) J.D. Cox & G. Pilcher, "Thermochemistry of Organic and Organometallic Compounds", Academic Press, NY (1970) 36) W.C. McCrone, *Microscope* **18** (4), 257 (1970) & *CA* **74**, 14683 (1971) 37) D.G. Grabar et al, *Microscope* **1970**, 18 (4), 241 & *CA* **74**, 14684 (1971)
 38) O.K. Pennington et al, *USP 3536544* (1970) 39) M.C. Chick et al, *JCrystalGrowth* **7**, 317 (1970) 40) D.G. Grabar et al, *Microscope* **18**, 241 (1971) 41) C. Lenchitz et al, *JChem-Thermodyn* **3** (5), 689 (1971) 42) M.A. Mel'nikov & N.P. Volkov, *IzvTomskPolitekhnInst* **180**, 93-97 (1971) & *CA* **76**, 88013 (1972)
 43) Anon, *EngrgDesHndbk*, "Explosives Series—Properties of Explosives of Military Interest", **AMCP 706-177** (1971) 44) E. Raisen, "Determination of the Vapor Pressure of TNT by the Radioactive Tracer Method", *Rept IITRI-C6222*, IIT Res Inst, Chicago (1971) (Limited distrib)
 45) M.C. Chick & D.J. Boyd, "The Effect of Grain Structure and Polymorphism on the Infrared Spectrum of 2,4,6-Trinitrotoluene", *Rept No DSL-TN-215*, Defense Standards Labs, Maribymong, Australia (1971) (Limited distrib)
 46) J.L. Soderberg et al, *USP 3620857* (1971) 47) M.E. Sitzmann et al, "Solubilities of High Explosives: Removal of High Explosive Fillers by Chemical Dissolution", **NOLTR-73-186**, Naval Ordn Lab, Silver Spring (1972) 48) D.S. Downs & A.C. Forsyth, "Optical Absorption of TNT Single Crystals", *PATR* **4565** (1973)
 49) W. Fisco & O. Haase, "Crystal Growth of Trinitrobenzene and Trinitrotoluene", *Materials-ResBull* **8**, 1083 (1973) 50) G.R. Gibson & R.L. Dickenson, "Study of Trinitrotoluene Exudates", *Rept RAD 240.10*, Radford Army Ammo Plant (1974) 51) B.M. Dobratz, "Properties of Chemical Explosives and Explosive Simulants", *Rept UCRL-51319*, Rev 1, Lawrence Livermore Lab, Livermore (1974) 52) D.C. Heberlein, "Density Changes of Alpha-Trinitrotoluene from 77° to 273°K", *Rept No USAMERDC-2112*, US Army Mobility Equipment Res & Dev Center, Ft. Belvoir (1974) (Limited distrib) 53) Omit 54) *Ibid*, "Dielectric Changes in Alpha-Trinitrotoluene", *Rept*

No **USAMERDC-2160** (1975) (Limited distrib) 55) Ibid, "Heat Capacity of Alpha-Trinitrotoluene", Rept No **USAMERDC-2161** (1975) (Limited distrib) 56) P.E. Rouse, Jr, *JChem-EngData* **21** (1), 16 (1976) & *CA* **84**, 92352 (1976) 57) Y. Hara & H. Osada, *Kogyo-Kayaku* **37** (5), 233 (1976) & *CA* **87**, 4829 (1977) 58) W. Schmacker, *Grundlagen Technol Anwend, Int Jahrest, Inst Chem Treib-Explosivst Fraunhofer-Ges*, 301-23 (1976) & *CA* **89**, 26971 (1979) 59) D.K. Philp & B.W. Thorpe, *JCrystalGrowth* **35** (2), 133 (1976) & *CA* **85**, 169776 (1976) 60) D.C. Heberlein, "Density Changes in Crystalline Alpha-Trinitrotoluene from 280° to 340°K", Rept No **USAMERDC-2202**, US Army Mobility Equipment Res & Dev Center, Ft Belvoir (1976) (Limited distrib) 61) Anon, US Mil Spec **MIL-T-248C** (1974) with Int Amendment I (PA) (1976) 62) P.L. Lagus et al, *Proplnts & Expls* **2** (4), 81 (1977) & *CA* **88**, 25088 (1978) 63) D.C. Leggett et al, "Composition of Vapors Evolved from Military TNT as Influenced by Temperature, Solid Composition, Age, and Source", US NTIS, AD Rept, Cold Reg Res Eng Lab, Hanover, NH (1977) (AD-A040632) 64) P.A. Pella, *JChemThermodyn* **9** (4), 301 (1977) & *CA* **87**, 11791 (1977) 65) D.C. Leggett, *JChromatogr* **133** (1), 83 (1977) & *CA* **86**, 157805 (1977) 66) R.A. Marino et al, "An NQR Study of TNT Characteristics", Rept No **BEI-77-701**, Block Engrg Inc, Cambridge, Mass (1977) 67) N. Davies & P.R. Lee, "Studies on the Crystallization of TNT-Based Explosives", paper presented at JTCCG/TTCP Expls Conf, Naval Surface Weapons Center, White Oak, Silver Spring (18-20 Oct 1977) 68) W.T. Jones et al, Rept **RARDE/TR-5/78**, Royal Armament R&D Establishment, Ft Halstead, Engl (1978) (Restricted distrib) 69) R.P. Parker & W.S. Wilson, "Growth of Creamed TNT in Thermal Cycling", Rept **MRL-R-720**, Dept of Defence, Melbourne, Australia (1978) 70) R.B. Cundell et al, *JChemSoc, FaradayTrans 1*, **74** (6), 1339-45 (1978) & *CA* **89**, 181933 (1978) 71) J. Eadie & W.S. Wilson, "Esters of 2,4,6-Trinitrobenzoic Acid and the Interfacial Tension between Wax and TNT", Mater Res Lab, Dept of Defence, Maribyrnong, Australia (1975) & *CA* **89**, 113422 (1978) 72) M.A. Parry & B.W.

Thorpe, "Nucleation and Growth of TNT Containing HNS", Rept No **MRL-R-708**, Mater Res Lab, Ascot Vale, Australia (1978) & *CA* **89**, 14886 (1978) 73) S.F. Trevino, S. Portnoy & C.S. Choi, "Effects of HNS on Cast TNT", Memorandum Rept **ARLCD-MR-79001**, ARRADCOM, Dover (1979) 74) W.C. Hogge, "Effect of HNS on Physical Properties of TNT Explosives: Surveillance Evaluation", **NWSY TR 79-1**, NavalWeapSta, Yorktown (1979) 75) M.J. Frankel, "Properties of Naval Explosives", **NSWC TR 79-147**, NavalSurfWeapCenter, Silver Spring (1980) 76) E.E. Gilbert, unpublished research data, ARRADCOM, Dover (no date) 77) Anon, Energetic Materials Div, unpublished research data, ARRADCOM, Dover (no date)

Explosive Properties

Sensitivity Data

The theory and practice of impact sensitivity testing are discussed in detail in Vol 7, I35-R ff (see also Vol 4, D392). Several types of equipment have been used on an empirical basis, and the results have often been difficult to reproduce. The qualitative conclusion can be drawn, however, that TNT is less sensitive to impact than all other common expls except Explosive D (ammonium picrate), and TATB. A similar conclusion can be drawn from data from other types of tests, such as the Susan Test, and from a comparison of critical initiation energies (Ref 141)

The impact sensitivity of TNT increases sharply with increasing temp, as shown below:

Temp (°C)	Inches*
-40	17
Room	14
80	7
90	3
105	2**

*Tests in PicArnsn app, 2-kg wt

**Five expls in 20 trials

Diminished sensitivity has also been noted with decreasing temp over the range -100 to +22° (Ref 109), and at -196° (Ref 142). Increase of pressure over the range 50 to 200Kbar results in a greatly increased temp for initiation by shock of molten TNT (Ref 106). Cast TNT is less sensitive than the pressed material, as shown by the Gap Test (Vol 4, D321), and by projectile

impact tests (Ref 99)

Finely-divided TNT, as obtained by fume condensation, is more sensitive to impact than the crystalline material (Ref 1); TNT which has been exposed to light is also more sensitive. TNT pellets pressed from flake TNT undergo substantial reductions in rate of detonation and sensitivity to initiation after storage for one week at 65° (Ref 2). These changes are accompanied by exudation of oily impurities, and recrystallization and sementation of the TNT

The course and mechanism of the shock initiation of TNT has been studied in some detail. A reaction sequence has been described (Ref 10) for the initiation of molten TNT by shocks of 80–89kb. The time-to-detonation of molten TNT at 150° was measured at an input strength of 130kbar (Ref 164). The heterogeneity of solid TNT greatly complicates the course of initiation (Refs 11 & 97), which has been studied in low-density (Ref 67), cast (Refs 13 & 85), and pelletized (Ref 85) expl. An understanding of initiation has been helped by the use of low-strength shocks (Refs 30, 68 & 121). The following data (Ref 30) show the differences between the pressures required to produce burning or detonation in pressed or cast TNT, using the Modified Gap Test:

	<u>Burning</u>	<u>Detonation</u>
Pressed	22 kb	50 kb
Cast	22 kb	(90 kb)*

*by extrapolation

Shock initiation has been studied in the presence of free-radical donors and getters (Ref 154). Detonation occurs only under particular vibration parameters (Ref 155). A new "ACP" (Augmented by Collision Pressure) method is said to be simpler and more reliable than conventional initiation procedures (Ref 105)

Tests commonly used to evaluate sensitivity to friction (see Vol 1, XIII) include the Pendulum Friction Test (see Vol 6, F204-L) and the Rifle Bullet Test (see Vol 2, B332-L), the latter test involving combined friction and impact. Data for these tests are given in Table 4:

Table 4

Explosive	Pendulum Friction Test (% explosion)	Rifle Bullet Test (% explosion)	Explosion Temp * (°C)
TNT	0	1 (low order)	475
RDX	20	100	260
Comp B	0	15	278
β-HMX	Explodes	—	327
NG	100	100	222

*unconfined

TNT is insensitive to rifle bullet impact at room temp, whether unconfined, or confined in iron, tin, or cardboard bombs. The same results were noted at 105–10° with tin or cardboard bombs, and in an iron bomb with an air space. In an iron bomb with no air space, 70% of the trials resulted in expln

Sensitivity to Heat and Electric Charge

The Ignition (or Explosion) Temperature Test measures thermal stability, which is discussed under "Chemical Properties". The test is run with the sample either confined or unconfined (see Vol 1, XVI). Test results are quite sensitive to conditions and to sample purity, and as a result, ignition values for TNT reported in the literature differ by as much as 200°C (Ref 156; see discussion in Vol 4, D583-L ff). Careful studies using different procedures with confined samples have given ignition temps of 275° (Ref 156), 295° (Ref 99) and 287–89° (Ref 144), compared to a calcd figure of 291° (Ref 144). Heating TNT in a closed glass capillary gave 320–35°. As noted in the table above, the figure for unconfined TNT is 475°, which is much higher than those of the other common expls listed. Similar data are given in Vol 4, D587. Results of the Koenon and Ide heat sensitivity test (Ref 99, p 166) also show that TNT is comparatively hard to ignite, which corresponds to actual experience in handling. The void volume of the containment vessel strongly influences the time-to-expln at the autoignition temp (Ref 157)

TNT, like RDX and Composition B, is not classified as dangerous with respect to hazard from electric sparks. Sensitivity to electrostatic discharge of TNT (thru 100 mesh) is 0.06 Joules (unconfined) and 4.4 Joules (confined); TNT can be detonated by electric discharge (Ref 108)

The above data indicate that TNT is com-

Table 5

Explosive	Sand Test, gms	Detonation Vel, m/sec (1)	Detonation Pressure, kbar (1) (3)	Cylinder Wall Vel, mm/ μ sec (4)
TNT	48.0	6,825 ⁽²⁾ (1.56)	178 (1.64)	1.18
RDX	59.0	8,350 (1.70)	325 (1.76)	—
Composition B	53.0	7,800 (1.66)	293 (1.74)	1.39
β -HMX	60.4	9,124 (1.84)	—	1.65
NG	58.7	7,700 (1.60)	—	—

(1) At spec gravity (gm/ml) given parenthetically

(2) Using a 1" diameter unconfined pressed charge; a similar cast charge gave 6,640m/sec

(3) Data from Vol 4, D463

(4) Data from Vol 4, D151, Table 2, at R-R₀ = 5mm

Table 6

Explosive	Heat of Detonation, cal/g	Ballistic Mortar Values	Trauzl Lead Block Data	Underwater Effectiveness	Cylinder Expansion Energy
TNT	1,080	1.00	100	1.00	1.00
RDX	1,280	1.50	170	1.16	—
Composition B	1,240	1.33	130	1.11	1.36
HMX	1,356	1.50	145	1.19	1.79
NG	1,486	1.40	185	—	—

paratively insensitive, but that sensitivity increases markedly with increase in temp and degree of confinement

Brisance

The meaning of the term, "brisance", is controversial, and is discussed in Vol 4, D149-R ff. It has been defined vaguely as "shattering power", and attempts were made to correlate it with empirical tests, such as the Sand Test, and with properties such as detonation velocity or pressure, or energy output. More recently, it has been defined as the ability to accelerate metal, as measured by a modified Cylinder Wall Test. Data in Table 5 show that TNT has low brisance compared to other expls regardless of the test used

Power

Several procedures have been used to measure the power of expls, ie, the ability to do work (see Vol 8, P364-L), which is fundamentally based on the heat of detonation. Test data comparative with TNT are given in Table 6. It is apparent that TNT has less power than the other materials listed, regardless of the type of test used

Detonation Parameters

Detonation parameter data for TNT are summarized below in Table 7

The critical charge diameter of stick charges of TNT is influenced by several factors, including initial density, grain size, initial temp (over the range -180 to $+280^{\circ}$) and the degree of crystallinity. In the last case, cast TNT with many crystn centers, as made by "creaming", has a smaller critical diameter than that made by conventional crystn from a clear melt. Cast and pressed charges of the same density have very different critical diameters. Detonation velocities of stick charges can be substantially increased by the presence of an axial channel ("channel effect"). Both of these subjects have been well reviewed by Johansson and Persson (Ref 99)

Other reports emphasize the importance of charge geometry in the detonation process. An empirical equation relates the specific impulse (see Vol 4, D394-L) of TNT disks to sample dimensions (Ref 138). The reaction time of pressed TNT is less than half of that of the cast material (Ref 122); these measurements were

Table 7

<u>Parameter</u>	<u>Value (Density)</u>	<u>Ref, or Encycl Vol, pg</u>
Detonation velocity	6.98km/sec (—)	158
	6.92km/sec (1.64)	141
	7.29km/sec (1.65)	Vol 4, D464
	6.95km/sec (1.64) ¹ ; 5.01km/sec (1.0) ¹	99
Detonation velocity differential	3.23 (between 1.0 and 1.64) ¹	99
Gurney velocity	7600ft/sec (—)	Vol 6, G195
Detonation pressure ⁴	222kbar (1.65)	Vol 4, D464
	190kbar (1.630)	141
	190kbar (1.64)	99
	190kbar (1.64); 202kbar (1.59)	Vol 4, D234
	187.2kbar (—)	20
Detonation temperature	2736°K (1.65)	Vol 4, D464
	3000°K (1.0); 3450 (1.59)	Vol 4, D591
Detonation energy	1265cal/g (1.65)	Vol 4, D464
	4.10kJ/g (1.65)	99
	1093cal/g ² ; 1032cal/g ³ (1.53)	69
	1080kcal/kg (—)	Vol 4, D381
Chapman-Jouguet particle velocity	1.83km/sec (1.59)	Vol 4, D234
	1.60km/sec (—)	107
VonNeumann peak pressure	237kbar (1.614)	Vol 4, D280
Gas evolved	684ℓ/kg (1.62)	Vol 1, A147
	690cm ³ /g (1.64)	99
Critical diameter	10.5–11.2mm (0.85) ^{5,6}	Vol 4, D198
	26.9mm (1.62) (cast)	79
	31.3mm (1.44) (liq)	79
Underwater equivalent weight (Pentolite standard)		79
Shock wave	0.84 (—)	79
Relative bubble energy	0.94 (—)	
Fragment effects		79
Average number	1070 (1.54) (pressed)	
	1850 (1.58) (cast)	
Average velocity(m/sec)	3620 (1.54) (pressed)	
	3570 (1.58) (cast)	

Footnotes to Table 7:

1. Based on extensive experiments sufficient for extrapolation to infinite diameter
2. Heavily confined
3. Both ends of cylinder open
4. For other measurements, see Refs 84 & 98
5. At 0.07–0.2mm particle size
6. See discussion in text

Table 8

Product ¹	CO ₂	CO	C _(s)	N ₂	H ₂ O	H ₂	NH ₃
Heavily confined	1.25	1.98	3.65	1.32	1.60	0.46	0.16
Both ends of cylinder open	1.07	2.56	3.28	1.34	1.40	0.74	—
Unconfined	0.06	5.89	1.01	1.36	0.17	2.31	0.02

1. Mole per mole TNT; trace amounts of CH₄, HCN, C₂H₆ were also noted

made with an Electromagnetic Velocity Gage. Calcs have been made of the relationship between detonation pressure and the shape of the cross reaction in a block of TNT of infinite length (Ref 147). Axially-oriented TNT crystals show unstable detonation, while radially-oriented crystals detonate smoothly (Ref 14). As indicated in Vol 4, D394-L, the detonation velocity of TNT increases from 6025 to 6440 m/sec as the density increases from 1.30 to 1.50g/cm³. A straight-line relationship has been demonstrated (Ref 150). The detonation temp also increases with density (Vol 4, D492-L). Both of these parameters are discussed in more recent papers (Refs 159 & 167). The critical impact energy and critical impact velocity have also been determined as functions of the density of TNT (Ref 150)

TNT detonation products vary with the degree of confinement (Ref 69), as shown in Table 8. It is apparent that increasing confinement shifts the formation of carbon monoxide to that of solid carbon, and the formation of hydrogen gas to that of water. The degree of conversion of the nitrogen atoms to elemental nitrogen remains consistent regardless of conditions

The Jones-Wilkins-Lee equation of state has been used to describe accurately the pressure-volume-energy behavior of the detonation products of expls in applications of metal acceleration. The parameters for TNT are available in comparison with other common expls (Ref 141)

Studies of the Detonation Process

Understanding of the basic factors of detonation, as of about 1970, has been reviewed by Johannson and Persson (Ref 99). Topics discussed include structure of the reaction zone and nature of the detonation process, with specific references to TNT. Conditions at the shock front, as described by Hugoniot, are reviewed in

Vol 7, H179-L ff. Major conclusions from more recent work are as follows:

A kinetic study of the decomn of cast TNT by shock waves led to the conclusion that the mechanism of decomn during initiation and during developed detonation is the same (Ref 166). Two new equations of state have been advanced (Refs 140 & 148) for application to detonation studies of TNT and other condensed expls. The structural phenomenology of gaseous detonation is thought to be extendable to solid expls (Ref 123). Electrical conductivity changes behind the shock front in TNT may result from the formation of solid carbon (Ref 139). The relationship between the detonation shock wave impulse of TNT and the degree of completeness of combustion of the expln products was investigated (Ref 145)

Large-Scale Blast Studies

During the late 1960's, numerous field tests were made involving the expln of a few pounds up to 500 tons of TNT at once. One objective of these expts was to obtain a better understanding of some of the effects of nuclear blasts. TNT was used because of the extensive knowledge of its properties, and because of its availability, low cost, and ease of casting into spheres, which were employed in most of the tests. In some of the larger tests, hemispheres were constructed from cast TNT blocks. The preparation of TNT spheres, centrally initiated by a spherical booster system, has been described up to weights of 1000 lbs (Ref 7). The types of photographic, spectrographic and photoelectric devices used to record these events have been described (Ref 73). Equipment used to monitor the detonation of smaller expl charges (up to 200 lbs) has also been discussed (Ref 51). Blast effect data in earth, air, and water, up to about 1962, is discussed in Vol 2, B180-L ff

Ground motion and stress measurements were made in detail at various depths and distances (Refs 42, 74, 88, 89, 90, 100, 110, 111, 112, 113, 124, 133, 134 & 160), using a variety of techniques, including ground gages (Ref 89), and displacement of pipes placed vertically in the ground (Ref 90). The types of soil included sand and clay of various degrees of wetness (Refs 5, 21 & 114), and rock of varying degrees of hardness, including limestone (Refs 22 & 23) and granite (Refs 43 & 125). The effect on ground water (Ref 52), and the extent of wave reflection in soil (Ref 114) were considered, as were also the nature and extent of cratering and the character of the ejecta (Refs 8, 91, 126 & 161). The craters were not found to seriously impede the motion of military vehicles (Refs 101 & 127). A theoretical study was made of expl ditching with TNT (Ref 162). Many of these studies include a comparison of observation with theory; one study (Ref 31) makes calcns toward predicting the degree of shock transmission thru various types of soil and rock

Atmospheric effects of large-scale TNT explns have also been studied in depth both practically and theoretically. Factors considered include pressure and impulse effects, decay characteristics and travel and duration times, all as a function of distance, and for both free-field and reflection situations (Refs 3, 9, 15, 16, 17, 24, 32, 33, 34, 35, 36, 44, 53, 75, 76, 115 & 116). A distinction is made between the blast area close to the source, comprising air and the products of expln, and that farther away involving air only (Ref 53). Double-burst conditions (fireball and shock wave interaction, and torus formation) have been studied (Ref 149), as have also the dynamics of dust formation and motion (Refs 25, 26 & 117). Performance tests were run on a naval blast valve (Ref 92), and on aircraft wing panels (Ref 4)

Summer and winter blast parameters are similar, except that in winter the pressure is less in the region below 200psi (Ref 45). Pressure and particle velocity data were obtained using 60 to 700-lb charges in a conical shock tube (Ref 70); the results agree with existing data. Measurements have been made of the degree of radio signal disturbance (Ref 27) and of the extent of electromagnetic radiation (Refs 12 & 77). A luminosity-time history shows several maxima

and minima (Ref 96); CN, CH, and NH^- were identified in the blue. Light in the early optical spectrum comes largely from impurities (Na, Ca, CN) (Ref 50). Study of emission from the luminous cloud in the 200–220km region indicates a temp of about 1250°K (Ref 19). [For further discussion of detonation luminosity, see Vol 4, D425-L and a review by Johansson and Persson (Ref 99, pp 179–99)]

Swisdak (Ref 143) has well summarized exptl data on expln effects in air as of 1975, nearly all of which refers to TNT. Topics covered include: (1) shock wave parameters for spherical explns in air (1 to 1000 lbs), peak pressure, time of arrival, positive impulse, and positive duration; (2) triple point loci for 1-lb charges at sea level; (3) peak overpressure, shock wave time of arrival, and shock wave positive duration — all three along the ground surface as a function of height of burst and the horizontal range from ground zero (1-lb charges); (4) altitude correction factors for converting blast effects for any charge at sea level to the same charge up to 100000 ft; (5) peak overpressure and positive impulse vs scale distance for spheres and hemispheres detonated on the surface (1 lb to 500 tons); (6) ratio of peak overpressures obtained from cylinders to that obtained from spheres as a function of scale distance from charge center; (7) blast characteristics at the shock front (shock velocity, particle velocity, density ratio, dynamic pressure, reflected pressure, as calcd from Rankine-Hugoniot relations); (8) reflected overpressure ratio vs angle of incidence for various incident overpressures; (9) airblast from underwater explns; (10) airblast from underground explns; (11) static pressure from expln in confined spaces; and (12) apparent crater parameters vs depth burial in various media (alluvium, basalt, dry clay shale, playa, sand). TNT shock wave transmission in air has also been reviewed by Johansson and Persson (Ref 99)

TNT spheres have also been employed for generating shock waves in water. They have been fired above (Ref 37) and just below (Ref 6) the surface, half-submerged (Ref 54), and at various depths ranging from 200 to 14000 ft (Refs 46 & 78). The theory of expl water wave generation has been reviewed (Refs 28 & 29), and measurements made (Refs 55, 102 & 171). Studies have been made underwater in an effort

to distinguish between earthquakes and explns (Refs 38 & 93). Shock-wave parameters were determined for a proposed standard for measuring underwater explns (Ref 135), comprising a 1:1 right cylinder machined from 80.4° spec gravity TNT pressed to 1600kg/m² weighing 0.45kg, centrally initiated. Underwater acoustic studies have shown no depth effect between 40 and 90m (Ref 172). Reflections can be used up to, and sometimes more than, 300 miles, with a 300-lb TNT charge as the acoustic source (Ref 79)

A useful compilation of data up to 1977 on expln effects in water, by Swisdak (Ref 165), includes the following specifically on TNT:

- (1) underwater shock parameters (1 to 512kg);
- (2) similitude constants for shock parameters;
- (3) underwater shock wave conversion factors;
- (4) pressure-pulse characteristics for deep explns;
- (5) underwater peak pressure produced at shallow depths by a spherical charge detonated at the water surface;
- (6) bubble parameters;
- (7) first period and maximum radius of an underwater gas bubble;
- (8) number of bubble oscillations before reaching the surface for a migrating bubble (140 to 900kg);
- (9) column and jet formation by a shallow underwater expln;
- (10) maximum height and radius of the plumes from an underwater expln; and
- (11) shock wave peak pressure and energy flux density produced by the detonation of line charges. Shock transmission in water from TNT charges is also reviewed more briefly by others (Ref 99)

Cratering of Greenland icecap snow has been studied using 20-ton (Ref 56) and smaller (Ref 94) surface blasts. Tests have been run on structures constructed of snow (Ref 39). Shock pressures have been measured from the expln of TNT spheres at various depths below 2 ft of ice (Refs 40 & 47)

Model rooms (Refs 57 & 80) and houses (Ref 170), communication tunnels (Refs 58, 81 & 118), magazines (Refs 128 & 163) and a storage bay (Ref 82), and concrete arches (Ref 59) and bunkers (Ref 103) have been exposed to up to 500-ton explns. Trees and automobiles have been similarly tested (Ref 129). Simulated human bodies have been tested in a coniferous forest (Ref 48). Foxholes showed little damage (Refs 41 & 95); sheep in open 2-man foxholes showed severe eardrum damage, but were otherwise unharmed except for slight pulmonary

hemorrhage (Ref 173)

A series of limited-access reports is also available on the effects of multi-ton TNT explns (Refs 49, 60, 61, 62, 63, 64, 65, 66, 71, 72, 83, 86, 87, 104, 119, 120, 130, 131, 132, 136, 137, 151, 152, 153 & 169)

Refs: 1) F.R. Benson, "Special Tests of Sensitivity of TNT", PATR **1188** (1942) 2) A.J. Clear, "Investigation of the Cause of Malfunctioning of Pressed TNT Blocks", PATR **1564** (1945) 3) W. Weibull, "Explosion of Spherical Charges in Air: Travel Time, Velocity of Front, and Duration of Shock Waves", **BRL-X-127**, Ballistic Res Lab, Aberdeen Prov Grnd (1950) 4) J.C. Talley et al, "Damage to Aircraft by Blast", **NPG-1058**, Naval Prov Grnd, Dahlgren (1952) 5) G.A. Young, "Base Surge Analysis—HE Tests", no Rept No, Naval Ordn Lab, Silver Spring (1952) 6) Anon, "Tests of Small-Scale Explosions in Extremely Shallow Water", **AEWES-Misc Paper-2-103**, Army Eng Waterways Exptl Sta, Vicksburg (1954) 7) A.M. Pennie et al, *Explosivst* **4**, 74 (1961) 8) R.H. Carlson & W.A. Roberts, "Ejecta Study of 100-Ton Suffield Explosive Cratering Shot", Rept **D2-90203**, Boeing Co, Seattle (1962) 9) C.N. Kingery et al, "Surface Air Blasts from a 100-Ton TNT Detonation", **BRL-MR-1410**, Ballistic Res Labs, Aberdeen (1962) 10) J.W. Enig & F.T. Metcalf, "Theoretical Calculations on the Shock Initiation of Liquid TNT", **NOLTR 62-159**, Naval Ordn Lab, Silver Spring (1962) 11) Ibid, "Theoretical Calculations on the Shock Initiation of Solid Explosives", **NOLTR 62-160**, Ibid (1962) 12) C.B. Dobbie & S.R. Hamilton, "Electromagnetic Measurements on Canadian 100-Ton TNT Explosion", **EGG-B-2572**, Edgerton, Germeshausen & Grier, Inc, Boston (1963) 13) A.N. Dremin et al, "The Initiation of Detonation by a Shock Wave in Cast Trotil", **NOTS-TP-4049** [Transl of ZhurPriklMekh i TekhnFiz **6**, 131–34 (1963)] 14) W. Kegler, "Sensitization of TNT with Nitrocellulose and other Additives", *Explosivst* **10**, 209 (1963) & *CA* **63**, 6779 (1965) 15) R.R. Mills, Jr et al, "Self-Consistent Blast Wave Parameters", Rept **ER 3589**, Aircraft Armaments Inc, Cockeysville, Md (1964) 16) J.M. Dewey, "The Air Velocity in Blast Waves from TNT Explosions", *Royal Soc of London Proceedings, Series A, Math&PhysSci* **279**, 366 (1964) 17) C.N.

- Kingery & B.F. Pannill, "Peak Overpressure Vs Scaled Distance for TNT Surface Bursts (Hemispherical Charges)", **BRL-MR-1518** (1964)
- 18) J.H. Stockhauser, *JAcousticalSoc of America* **36** (6), 1220 (1964) 19) O. Harang, *Planetary-&SpaceSci* **12**, 567 (1964) 20) N.L. Coleburn, "Chapman-Jouguet Pressures of Several Pure and Mixed Explosives", **NOLTR 64-58** (1964)
- 21) C.V. Fulmer, "Cratering Characteristics of Wet and Dry Sand", Rept **D2-90683-1**, Boeing Co, Seattle (1965) 22) R.C. Bass & H.L. Hawk, "Close-In Shock Studies", Sandia Corp, Albuquerque (1965) 23) M.V. Anthony et al, "Ejecta Distribution from Flat Top 1 Event", Boeing Co, Seattle (1965) 24) M. Lutzky, "Theoretical Vs Experimental Results for Air Blast from One-Pound Spherical TNT and Pentolite Charges at Sea Level Conditions", **NOLTR-65-57**, Naval Ordn Lab, Silver Spring (1965) 25) T.D. Witherly, "Field Testing of Instruments for Measurement of Dusty Airblast Effects", Final Rept, Stanford Res Inst, Menlo Park (1965) 26) J.M. Dewey, *Nature* **205**, 1306 (1965) 27) L.J. Griffiths et al, "HF Radio Measurements of the High-Altitude Acoustic Effects of a Ground-Level Explosion", Rept **SEL-54-062**, Stanford Univ (1965)
- 28) B.M. LeMehaute et al, "Contributions to the Mino Lake Experiments. Vol I. Predictions of the Water Waves and Run-Up Generated by TNT Explosions in Mino Lake", Rept **NESCO-S-256-2-Vol 1**, Natl Engrg Science Co, Pasadena (1965) 29) R.W. Whalin, "Contributions to the Mino Lake Experiments. Vol II. The Linear Theory of Water Waves Generated by Explosions", Rept **NESCO-S-252-2-Vol 2**, Ibid (1965)
- 30) T.P. Liddiard, Jr & S.J. Jacobs, "Initiation of Reaction in Explosives by Shocks", **NOLTR 64-53** (1965) 31) C.S. Godfrey et al, "Calculations of Underground and Surface Explosions", **PIFR-013**, Physics International, San Leandro, Ca (1966) 32) W.A. Whitaker et al, "Theoretical Calculations of the Phenomenology of HE Detonations. Vol I", **AFWL-TR-66-141-Vol 1**, Air Force Weapons Lab, Kirtland AFB, NM (1966) 33) Ibid, "Ibid. Vol II", **AFWL-TR-66-141-Vol 2** (1966) 34) C.E. Needham et al, "Theoretical Calculations of the Detonation of a 1000-Pound Sphere of TNT at 15 Feet Above Ground Level", **AFWL-TR-66-128**, Ibid (1966) 35) C.N. Kingery, "Air Blast Parameters Vs Distance for Hemispherical TNT Surface Blasts", **BRL-1344**, Ballistic Res Lab, Aberdeen Proving Grnd (1966) 36) R.E. Reisler et al, "Basic Air Blast Measurements from a 500-Ton Detonation, Project 1.1, Operation Snowball", **BRL-MR-1818** (1966) 37) J.M. Pinkston, Jr & A. Sakurai, "Water Shock Waves from Above-Water Explosions", Rept **AEWES-Misc Paper-1-808**, Army Engineers Waterways Exptl Sta, Vicksburg (1966) 38) R.G. Reakes et al, "Long-Range Seismic Measurements V", Rept No **TR-66-71**, Geotech Div, Teledyne Industries, Garland, Texas (1966) 39) H. Szostak & R. Benert, "Effect of Explosions on Snow Structures", **TR-92**, Cold Regions Res & Eng Lab, Hanover, NH (1966) 40) R.M. Barash, "Measurements of Underwater Explosion Pulses Reflected from an Ice Layer", Naval Ordn Lab, Silver Spring (1966) 41) R.A. Hobbs, "Effects of Airblast on Unrevetted Earth Walls", **AERDL-1872**, Army Engineer R&D Lab, Fort Belvoir (1966) 42) D.W. Murrell, "Operation Snowball. Project 3.6. Earth Motion Measurements", **AEWES-TR-1-759**, Army Engineer Waterways Exptl Sta, Vicksburg (1967) 43) J.H. Gee, "Multiple Threat Cratering Experiment. Vol II. Ground Motion in Rock", **AFWL-TR-67-8-Vol 2**, Air Force Weapons Lab, Kirtland AFB, NM (1967) 44) E.A. Nawrocki et al, "Theoretical Calculations of the Phenomenology of Distant Plain Event 6", **AFWL-TR-67-57**, Ibid (1967) 45) R.E. Reisler et al, **BRL-MR-1894**, Ballistic Res Lab, Aberdeen Prov Grnd (1967) 46) J.F. Slifko, **NOLTR-67-87**, Naval Ordn Lab, Silver Spring (1967) 47) C.E. Joachim, "Shock Transmission Through Ice and Snow", **TR-1-794**, Army Engineer Waterways Exptl Sta, Vicksburg (1967) 48) E.R. Fletcher et al, "An Estimation of the Personnel Hazards from a Multi-Ton Blast in a Coniferous Forest", Lovelace Foundation for Medical Education & Res, Albuquerque (1967) 49) J. Healy et al, "Decoupling of Seismic Waves from a Shot-Generated Cavity", Suppl Note, Geological Survey, Menlo Park, Ca (1967) 50) L. Rudlin et al, "The Early Optical Spectrum and Airshock from a 500-Ton TNT Explosion", **NOLTR-67-94**, Naval Ordn Lab, Silver Spring (1967) 51) T.C. Chamness et al, **NWC-TP-4670**, Naval Weap Centr, China Lake (1968) 52) J.L. Gatz, **AEWES-Misc Paper-3-990**, Army Engineer Waterways Exptl

- Sta, Vicksburg (1968) 53) G.F. Kinney, "Engineering Elements of Explosions", **NWC-TP-4654**, Naval Weap Centr, China Lake (1968)
- 54) A. Sakurai et al, "Blast Phenomena from Explosions at the Water Surface", Army Engineer Waterways Exptl Sta, Vicksburg (1968)
- 55) N.R. Wallace & C.W. Baird, "Explosion Generated Waves. 1965 Mono Lake Test Series", **OSI-102-2**, Oceanographic Services Inc, Santa Barbara (1968) 56) R.E. Bates & J.R. Hicks, "Effects of a 20-Ton TNT Explosion on a Snow Cover", **CRREL-SR-120**, Cold Regions Res & Engrg Lab, Hanover, NH (1968) 57) G.A. Coulter, "Air Shock Filling of Model Rooms", **BRL-MR-1916**, Ballistic Res Labs, Aberdeen Prov Grnd (1968) 58) A. Skjeltop, "One Dimensional Blast Wave Propagation", FortifikatoriskNotert **4769**, Norwegian Defence Construction Service, Office of Test & Development, Oslo, Norway (1968) 59) T.E. Kennedy, Misc Paper **1-963**, Army Engineer Exptl Sta, Vicksburg (1968) 60) J. Watson & E. Huestis, "A Method for Evaluating the Performance of Very Long Explosive Charges", Rept **DRES-Memo-60/67**, Defence Res Establishment, Suffield, Ralston, Alberta, Canada (1968) (Limited distrib) 61) A.D. Rooke, Jr et al, **AEWES-Misc Paper-1-987**, Army Engineers Waterways Exptl Sta, Vicksburg (1968) (Limited distrib) 62) G.D. Jones & W.A. Roberts, "Operation Distant Plain; Event 6; Project 3.12; Permanent Ground Displacement", Final Rept, Boeing Co, Seattle (1968) (Limited distrib) 63) omit 64) C.H.H. Diehl & J.H. Pinnell, "Crater and Ejecta Data from the Detonation of a 40,000-lb Spherical Charge of TNT Tangential to the Surface", **DRES-TN-207**, Defence Res Establishment, Suffield, Ralston, Alberta, Canada (1968) (Limited distrib) 65) Anon, "Operation Distant Plain, Preliminary Report, Vol IV", **DASIAC-SR-53-4**, Gen Electric Co, DASA Information & Anal Center, Santa Barbara (1968) (Limited distrib) 66) C.N. Kingery, "Parametric Analysis of Sub-Kiloton Nuclear & High Explosive Air Blast", **BRL-1393**, Ballistic Res Labs, Aberdeen Prov Grnd (1968) (Limited distrib)
- 67) L.G. Bolkhovitinov et al, 12th Int Symp Combustn Proc, 771-777 (1968) & **CA 74**, 143971 (1971) 68) T.P. Liddiard, Jr, "Low Amplitude Shock Initiation of Burning in High Explosives", **NTIS AD-827/4ST** (1968)
- 69) D.L. Ornellas, **JPhysChem 72**, 2390 (1968)
- 70) W.A. Fraar, "Pressure and Particle Velocity Measurements in DASACON", **KN-69-478 (R)**, Kaman Nuclear, Colorado Springs (1969)
- 71) J.H.B. Anderson, "Canadian Air Blast Measurements from Operation Distant Plain, Events 5A and 6", **DRES-TN-197**, Defence Res Establishment, Suffield, Ralston, Alberta, Canada (1968) (Limited distrib)
- 72) J. Wisotski, "Early Explosion Phenomena from Operation Distant Plain", Rept **DRI-2448**, Denver Res Inst, Denver (1968) (Limited distrib) 73) Ibid, "Technical Photography and Explosion Phenomenology Measurements from Operation Prairie Flat", Final Rept, Denver Res Inst, Denver (1969) 74) C.T. Vincent, "Earth Pressure and Ground Shock Profile Measurements", Final Rept, Proj No **LN-304**, Denver Res Inst, Menlo Park, Ca (1969) 75) D.L. Lehto & R.A. Larson, **NOLTR-69-88**, Naval Ordn Lab, Silver Spring (1969) 76) C.E. Needham & T.H. Burghard, **AFWL-TR-69-105**, Air Force Weap Lab, Kirtland AFB, NM (1969)
- 77) G. Broekstra, "High Frequency Electromagnetic Radiation—Operation Prairie Flat", **DRES-Memo-14/69**, Defence Res Establishment, Suffield, Ralston, Alberta, Canada (1969)
- 78) W.A. Hardy, "Shot Source Spectra and Bottom Reflectivity Data", **TR-179**, Hudson Labs, Columbia Univ, Dobbs Ferry (1969)
- 79) Ibid, "Seamount Detection by Cross Correlation of Reverberation Echoes", **TR-169**, Ibid (1969) 80) G.A. Coulter, "Air Shock and Flow in Model Rooms", **BRL-MR-1987**, Ballistic Res Labs, Aberdeen Prov Grnd (1969)
- 81) E. Stroemsoc, "Detonation Trials in a Funnel System", **NDRE-X-122**, Norwegian Defence Res Establishment, Kjeller, Norway (1969)
- 82) Anon, "Evaluation of Explosives Simultaneity Tests", **NWC-TP-4720**, Naval Weap Centr, China Lake (1969) 83) A.M. Patterson, "Blast Anomaly Studies—Operation Prairie Flat", **DRES-Memo-16/69**, Defence Res Establishment, Suffield, Ralston, Alberta, Canada (1969) (Limited distrib) 84) A.N. Dremin & K.K. Shvedov, "Determination of the Chapman-Jouguet Pressure and the Reaction Duration in a Shock Wave of High Power Explosives" (Engl Transl), **PATT-154**, PicArns, Dover (1969)
- 85) A.N. Dremin & S.A. Koldunov, "Initiation of Detonation by Shock Waves in Cast and Pellet-

- ized TNT", **UCRL-Transl-10408**, Lawrence Radiation Lab, Univ of California, Berkeley (1969)
- 86) R.E. Reisler et al, "Air Blast Measurements from the Detonation of Large Spherical TNT Charges Resting on the Surface", **BRL-MR-1955**, Ballistic Res Labs, Aberdeen Prov Grnds (1969)
- 87) P. Lieberman et al, **ITRI-J6158-FR**, IIT Res Inst, Chicago (1969) (Limited distrib)
- 88) D.W. Murrell, "Stress Measurements", **AEWES-TR-N-7014**, Army Engineer Waterways Exptl Sta, Vicksburg (1970)
- 89) F.W. Galbraith, "Shock Spectrum Measurements", Rept **10513-6002-R000**, TRW Systems Group, Redondo Beach, Ca (1970)
- 90) G.D. Jones & F.W. Davies, "Ground Displacement Study", Final Rept, Boeing Co, Seattle (1970)
- 91) D.H.S. Jones et al, "Crater and Ejecta Study", Final Rept, Defence Res Establishment, Suffield, Ralston, Alberta, Canada (1970)
- 92) J. Norbutas et al, "High Explosive Field Test of BUSHIPS Blast Valve", **NCEL-TN-1180**, Naval Civil Engrg Lab, Port Hueneme, Ca (1971)
- 93) G.B. Morris, *Deep-Sea Research* **17**, 913 (1970)
- 94) J.A. Conway & J.W. Meyer, "Cratering in Greenland Icecap Snow", **AEWES-Misc Paper-N-70-6**, Army Engineer Waterways Exptl Sta, Vicksburg (1970)
- 95) E.P. Leland, "Evaluation of a Foxhole Cover", Final Rept, Army Mobility Equipment R&D Center, Fort Belvoir (1970)
- 96) L. Rudlin, **NOLTR-69-179**, Naval Ordn Lab, Silver Spring (1970)
- 97) D. Price, "Shock Sensitivity, A Property of Many Aspects", **NOLTR-70-73**, Naval Ordn Lab, Silver Spring (1970)
- 98) R.L. Jameson & A.L. Hawkins, "Detonation Pressure Measurements in TNT & Octol", Ballistic Res Labs, Aberdeen Prov Grnd (1970)
- 99) C.H. Johanson & P.A. Perrson, "Detonics of High Explosives", Academic Press, NY (1970)
- 100) J.K. Ingram, **AEWES-TR-N-71-3**, Army Engineer Waterways Exptl Sta, Vicksburg (1971)
- 101) C.A. Blackmon & A. Rula, **AEWES-Misc Paper-M-71-4**, Ibid (1971)
- 102) B.M. Buck & A.W. Magnison, "Measurements of Underwater Explosive Source Levels for Yields of 0.0012 to 126 Pounds", **TR 73-02**, Delco Electronics Div, General Motors Corp, Santa Barbara (1971)
- 103) R.K. McGrath, "Dynamic Response of Concrete Arch Bunkers; Event Dial Pack, Project LN 314A", **AEWES-TR-N-71-8** (1971), Army Engineer Waterways Exptl Sta, Vicksburg (1971)
- 104) R.E. Reisler et al, "Blast Measurements from the Detonation of Tower-Placed 20-Tons of Spherical TNT", **BRL-MR-2089**, Ballistic Res Labs, Aberdeen Prov Grnd, Aberdeen (1971) (Limited distrib)
- 105) A.J. Dedman & A.L. Lovecy, *Explosivst* **19**, 64 (1971)
- 106) R. Shaw, *JChemPhys* **54**, 3657 (1971)
- 107) D.J. Edwards & J.O. Erkman, "The Measurement of Particle Velocity in Cast TNT", **NOLTR-71-19**, Naval Ordn Lab, White Oak, Silver Spring (1971)
- 108) M.A. Mel'nikov & N.P. Volkov, *IzvTomskPolitekhnInst* **180**, 93 (1971) & *CA* **76**, 88013 (1972)
- 109) J.E. Plum, "The Effect of Low Temperature on the Impact Sensitivity of TNT", Masters Thesis, Naval Postgraduate School, Monterey (1972)
- 110) D.W. Murrell, **AEWES-TR-N-72-2** (1972), Army Engrs Waterways Exptl Sta, Vicksburg (1972)
- 111) Ibid, **AEWES-TR-N-72-6**, Ibid (1972)
- 112) I.S. Sandler et al, "Pretest Ground Motion Calculations for the Mixed Company Event of the Middle North Series", Weidlinger Associates, New York (1972)
- 113) L.F. Ingram, "Ground Motions from High Explosive Experiments", **AEWES-Misc Paper-N-71-10**, Army Engrs Waterways Exptl Sta, Vicksburg (1972)
- 114) G.M. Lyakhov & R.I. Dubova, "Waves in Soil During a Surface Blast and their Interaction with Obstacles", **FTD-HT-23-744-72** (Transl), Foreign Technol Div, Wright-Patterson AFB, Dayton (1972)
- 115) L. Giglio-Tox, "Fundamental Blast Studies", **DNA-POR-6744**, Defense Nuclear Agency, Washington (1972)
- 116) L.E. Fugelso & S.F. Fields, "Dial Pack Blast Directing Experiment", **GARD-1506-F**, General American Transportation Corp, Niles, Ill (1972)
- 117) D. Freeman et al, "Dynamic Dust Measurements for Middle Gust Event II", **TRW-20295.000**, TRW Systems Group, Redondo Beach (1972)
- 118) G. Nevrincean & E.F. Witt, "Blast Valve Tests", **DNA-POR-6742**, Defense Nuclear Agency, Washington (1972)
- 119) W.J. Fenrick & B.R. Campbell, "Canadian Blast Wave Density-Time Measurements on Event DIAL PACK", Defence Res Establishment, Suffield, Ralston, Alberta, Canada (1972) (Limited distrib)
- 120) A.D. Rooke, Jr et al, "DIAL PACK: Crater and Ejecta Measurements from a Surface-Tangent Detonation on a Layered Medium", Final Rept, Army Engr Waterways Exptl Sta, Vicksburg

- (1972) (Limited distrib) 121) D. Tabor et al, "Initiation of Explosives by Low Strength Shocks", Univ Cambridge, Cambridge, Engl (1972) & CA 78, 99942 (1973) (AD Rept 1972, No 750706) 122) D.J. Edwards et al, "The Measure of Particle Velocity in Pressed TNT", **NOLTR-72-82**, Naval Ordn Lab, White Oak (1972) 123) P.M. Howe & G. Melani, "Oscillatory Behavior of Detonating Solid Explosives", Ballistic Res Labs, Aberdeen Prov Grnd (1972) 124) D.W. Murrell, **AEWES-TR-N-73-4**, Army Engr Waterways Exptl Sta, Vicksburg (1973) 125) J.W. Meyer & A.D. Rooke, Jr, **AEWES-Misc Paper-N-73-4**, Ibid (1973) 126) G. Ialongo, "Prediction Calculations for the Mixed Company III Event", Shock Hydrodynamics, Sherman Oaks, Ca (1973) 127) C.E. Green, **AEWES-Misc Paper-M-73-5**, Army Engr Waterways Exptl Sta, Vicksburg (1973) 128) F.H. Weak, "Eskimo I Magazine Separation Test", **NWC-TP-5430**, Naval Weapons Center, China Lake (1973) 129) R.E. Warren, "Tree and Automobile Debris", Bell Telephone Labs, Whippany, NJ (1973) 130) Anon, "Event DIAL PACK Symposium Report, Vol I", no publisher given (1973) (Limited distrib) 131) Ibid, "Vol II" (1973) (Limited distrib) 132) C.N. Kingery & R.C. Kellner, "Airblast Overpressure Versus Time Histories (Nuclear and TNT Surface Bursts)", **BRL-1638**, Ballistic Res Labs, Aberdeen Prov Grnds (1973) (Limited distrib) 133) D.W. Murrell, **AEWES-TR-N-74-3**, Army Engr Waterways Exptl Sta, Vicksburg (1974) 134) I.S. Sandler et al, "Ground Motion Calculations for Events II and III of the Middle Gust Series", Weidlinger Associates, New York (1974) 135) J.A. Hicks et al, "Pressed TNT as a Standard for the Assessment of Underwater Explosives. Part I", **ERDE-TR-164**, Expls Res & Development Establishment, Waltham Abbey, Engl (1974) 136) J. Peles, "Middle North Series, Mixed Company III Event, Anomalies", Final Rept, Naval Ordn Lab, White Oak, Silver Spring (1974) (Limited distrib) 137) A.L. Knapper et al, "Middle North Series, Mixed Company Event, Test Execution Report", Final Rept, General Electric Co, Santa Barbara (1974) (Limited distrib) 138) I.V. Ulas'ev, "Experimental Determination of the Impulse from an Explosive", *MetallodedProchnMater-(USSR)* 6, 245 (1974) & CA 84, 152870 (1976) 139) A.N. Dremin et al, "Electrical Conductivity of Explosives During the Initiation of Detonation by Shock Waves", **FSTC-HT-23-0780-73** (Transl), Army Foreign Sci & Technol Center, Charlottesville, Va (1974) 140) J.C. Edwards & R.F. Chaiken, "Detonation Calculations with a Percus-Yevick Equation of State", **BuMines-RI-7905**, Washington (1974) 141) B.M. Dobratz, "Properties of Chemical Explosives and Explosive Simulants", **UCRL-51319**, Lawrence Livermore Lab, Univ of Calif (1974) 142) L. Avrami et al, "Low Temperature Effects on TNT", **PATR 4780**, PicArnsn, Dover (1975) 143) M.M. Swisdak, Jr, "Explosion Effects and Properties. Part I. Explosion Effects in Air", **NSWC/WOL/TR 75-116**, Naval Surface Weap Center, Silver Spring (1975) 144) R.N. Rogers, *ThermochemicaActa* 11, 131 (1975) 145) G.G. Rempel et al, "Effect of the Complete Burning of TNT Explosion Products on the Shock Wave Impulse in Air", *VzryonoeDelo* 75, 60 (1975) & CA 84, 152876 (1976) 146) L.V. Shurshalov, *IzvAkadNaukSSSR, MekhZhidkGaza* (5), 130-35 (1975) & CA 84, 152878 (1976) 147) H.R.W. Weibull, Rept **F-103-44**, Fortifikationsfoervaltningen, Stockholm, Sweden (1975) & CA 88, 173087 (1978) 148) V.E. Fortov & A.N. Dremin, *DoklAkadNaukSSSR* 222 (1), 162-65 (1975) & CA 83, 82266 (1975) 149) J.H. Keefer & R.E. Reisler, "Multiburst Environment-Simultaneous Detonations Project Dipole West", **BRL-1766**, Ballistic Res Labs, Aberdeen Prov Grnds (1975) 150) Ya.M. Vasil'ev, Deposited Doc ViNiT1, 1247-76 (1975) & CA 88, 76093 (1978) 151) R.W. Pinker, "Middle GUST Cratering Data Report", **AFWL-TR-76-19**, Air Force Weapons Lab, Kirtland AFB, NM (1976) (Limited distrib) 152) J. Wisotski, "Middle North Series. Pre-Dice Throw I and II Events, Technical Photography", Final Rept, Denver Res Inst, Denver (1976) (Limited distrib) 153) R.W. Pinker, "Middle North Series. Mixed Company Event. Small High-Explosive Cratering Calibration Tests", Final Rept, Air Force Weapons Lab, Kirtland AFB, NM (1976) (Limited distrib) 154) F.E. Walker, "Effects of Free Radicals in the Shock Initiation of Explosives", **UCID-16858-76-1**, Lawrence Livermore Res Lab, Livermore, Ca (1976) 155) N.P. Leginov et al, "Initiation of Explosion and Kinetics of

Explosive Decomposition Under Vibration", *CombustExplosShockWaves* **12** (3), 367-70 (1976) 156) J. Harris, *ThermochimActa* **14** (1 & 2), 183-99 (1976) & *CA* **84**, 107975 (1976) 157) E. Catalano et al, "Thermal Decomposition and Reaction of Confined Explosives", **UCRL-78245**, Lawrence Livermore Lab, Livermore, Ca (1976) 158) P.E. Rouse, Jr, *JChemEngData* **21** (1), 16 (1976) 159) A.A. Evstigneev et al, "Isentropic Expansion and Equation of State of TNT Explosion Products", *FizGoreniyaVzryva* **12** (5), 758 (1976) & *CA* **86**, 92702 (1976) 160) G.L. Perry et al, "Analysis of Ground Motion Data and Prediction Techniques from the Pre-Dice Throw II Events", Final Rept, General Electric Co, Albuquerque (1977) 161) J.K. Ingram, "CENSE Explosion Test Program. Report 2. CENSE 2. Explosions in Soil", **WES-TR-N-77-6**, Army Engrs Waterways Exptl Sta, Vicksburg (1977) 162) A.M. Muller & H.D. Carleton, "Explosive Ditching with TNT", **WES-MP-N-77-7**, Ibid (1977) 163) F.H. Weale & C.H. Wilson, "ESKIMO IV. Magazine Separation Test", **NWC-TP-5873**, Naval Weap Centr, China Lake (1977) 164) J.B. Ramsey et al, "High Temperature Shock Initiation of Explosives", **LA-7158**, Los Alamos Sci Lab, Los Alamos (1978) & *CA* **89**, 181935 (1978) 165) M.M. Swisdak, Jr, "Explosion Effects and Properties: Part II—Explosion Effects in Water", **NSWC/WOL-TR-76-116**, Naval Surface Weap Centr, Silver Spring (1978) 166) G.I. Kanel, "Kinetics of Decomposition of Cast TNT in Shock Waves", *FizGoreniyaVzryva* **14** (1), 113 (1978) & *CA* **88**, 193969 (1978) 167) L.N. Akimova et al, "Detonation Parameters of Low-Density Condensed Explosives", *FizGoreniyaVzryva* **14** (2), 135 (1978) & *CA* **89**, 61995 (1978) 168) M.N. Borzykh & B.N. Kondrikov, Ibid **14** (1), 117 (1978) 169) J.H.B. Anderson, "Canadian Air Blast Measurements from Operation DISTANT PLAIN, Event 1A", **DRES-TN-225**, Defence Res Establishment, Ralston, Alberta, Canada (no date) (Limited distrib) 170) C. Wilton, "Assessments of House Damage from Event Dial Pack and 100 Ton AN/FO Test", **URS-788-2**, URS Research Co, San Mateo (no date) 171) A.R. Kriebel, "Cavities and Waves from Explosion in Shallow Water", **URS-679-5**, URS Research Co, Bur-

lingame, Ca (no date) 172) A. Skretting, "Acoustic Calibration of an Explosive Sound Source", **SACLANTCEN-TM-54**, SACLANT ASW Research Centre, La Spezia, Italy (no date) 173) D.R. Richmond et al, "The Effects of Airblast on Sheep in Two-Man Foxholes", (no date, no further info)

Disposal of Waste TNT

The disposal of waste TNT has become of increasing concern in recent years as environmental regulations have become steadily more stringent. Procedures are required for handling solid expls of varying amount, composition and age, as well as for the many types of expl plant waste water streams which contain low concns of TNT (ca 120-150ppm). These procedures must be safe and efficient, and must yield non-toxic effluents. In the case of the waste waters, preliminary concn of TNT may be required before disposal, and in many cases the waste water no longer contains pure TNT, but its transformation products, over 40 of which were detected in one study (Ref 24). Exposure to light, for instance, gives rise to many derivatives, as discussed in the section on the photochemical reactions of TNT. In Table 9 below are listed common procedures for destroying TNT, as well as methods studied for concentrating TNT from aq solns:

Table 9

* Concentration and Destruction Methods for TNT

Concentration Methods

- *Carbon adsorption
- *Solvent extraction
- *Complexing with surfactant
- Distillation
- Reverse osmosis
- Polymer adsorption
- Liquid membrane
- Foam
- Water recycle

Destruction Methods

- *UV light with ozone or other oxidant
- *Incineration
- Composting (biodegradation)
- Ozonolysis
- Gamma radiation
- Explosion
- Chemical

*Indicates preferred procedure

The preferred methods have shown exptl promise to date, while the others have objections, among which are high cost, inefficiency, operating hazards, or creation of secondary pollution problems. The identity and toxicity of all of the destruction products have not been completely determined in many cases, which must be done before any process is approved for general use

Activated carbon has long been widely used for purification of munitions plant waste water. A study of repetitive solvent regeneration of spent carbon with acetone (Ref 10) has shown that a 24% drop in efficiency occurs with the first regeneration, followed by successively lower losses in efficiency with subsequent regenerations. It is suggested that the use of hot acetone may improve regeneration efficiency. Studies of the use of synthetic resins instead of carbon (Refs 5, 17, 25 & 34) have shown that "Amberlite XAD" has greater capacity for TNT removal than carbon, but less capacity for removing other expls in the waste water, and less ability to remove color. Solvent extraction of waste water with toluene has in one situation been found to give usable TNT (Ref 3). Certain long-chain amines form insoluble complexes with TNT (Refs 23, 26 & 35); this approach has been considered for its removal from water solns. Membrane ultrafiltration removes TNT and gives water suitable for reuse (Ref 27). TNT suspended in waste water can be recovered by adding flocculating agents, but only certain materials are compatible (Ref 28)

TNT in dilute aq soln can be rapidly destroyed, ie, converted to ionic species (CO_2 , HNO_3 , H_2O) by exposure to UV light. Although this treatment is usually applied with an oxidizing agent - ie, ozone (Refs 22 & 42), ozone plus activated carbon (Ref 36), or hydrogen peroxide (Refs 29 & 30), it will also proceed with simple exposure to air, and even in closed vessels (Ref 14). This type of procedure is obviously of special interest, because it eliminates a concn step, and proceeds rapidly and completely. A 1000 gal per day pilot test of the UV-ozone procedure reduced dissolved TNT and RDX to < 1mg/liter, with no by-products requiring disposal (Ref 37). These encouraging results may be studied further at the 5000 gal per day level. The use of UV-Ozone (a commercial mixt of K monopersulfate, K hydrogen sulfate, and K

sulfate) is more efficient than UV-hydrogen peroxide (Ref 37). Further study of this process may await the development of more cost-effective equipment

Incineration has been a favored method for the disposal of TNT and other waste munitions (see "Destruction and Disposal of Explosives", Vol 3, D25-R ff), including the spent activated carbon employed for treating waste water. Fluid bed incineration is especially promising in comparison with other types of incineration used in the past (Refs 12 & 40). This approach has comparatively high combustion efficiency, low gaseous and particulate emissions, high heat sink capacity, low operating cost and inherent safety features. The process operates at 870-1000°, with the fluid bed comprising 94% Al oxide and 6% Ni oxide; the latter catalytically reduces the quantities of objectionable effluents (NO_x , CO, hydrocarbons) to ca 5-10% of the amount obtained without the catalyst. Operating parameters were optimized with slurries containing 40% or less TNT; slurries with > 55% TNT are potentially expl

Biodegradation by composting showed initial promise for disposal of waste TNT, since fairly large quantities of TNT (up to 10% of the dry weight of the compost) could be degraded in a reasonable time (Ref 32). Degradation in soil, on the other hand, is considered too slow (Refs 21 & 32). Bacteria differ in their ability to metabolize TNT. Some can use it as their sole source of carbon and nitrogen (Refs 8 & 15), while others require dietary supplements (Ref 7). Stepwise reduction of the nitro groups occurs to amine and other groups less energetic than nitro (Refs 2, 7 & 16). Many fungi can also transform TNT (Ref 31)

A three-year pilot study of the biodegradation of aq solns of TNT under various conditions has, however, given no evidence for cleavage of the aromatic ring (Ref 38). Another report (Ref 39) reaches the same conclusion, and further shows that the TNT-derived amines form polyamides which resist further biodegradation. These findings constitute a serious objection to the biodegradation concept for the disposal of TNT, since the toxicity of these ring compds is unknown. Similar compds are, however, known to be toxic. The UV-ozone method of disposal, on the other hand, desirably converts TNT rapidly

to CO_2 , HNO_3 and H_2O

Destruction of 40-lb charges of TNT can be effected in a 5-ft diameter spherical blast containment chamber (Ref 13)

TNT can be destroyed by chemical methods. It can be converted to a water-soluble, insensitive material, not susceptible to initiation, by treatment for 15 minutes at 87° , with 30 wts of a 15% soln of Na sulfide nonahydrate (Ref 1). Amm sulfide behaves similarly, but reacts much more slowly. These procedures involve reduction of the nitro groups to amino and other groups less energetic than nitro. TNT can be rapidly rendered non-expl by treatment with isopropylamine in a good solvent for TNT (eg, acetone or acetonitrile) (Ref 18). This system has been studied for destroying land mines (Refs 11 & 18). Destruction of the nitro groups in this system apparently occurs by the base-promoted redox reactions discussed under the reaction of TNT with bases. These chemical methods produce products of unknown toxicity, and are therefore suitable only for the treatment of small amounts of material on an occasional basis

Other (limited-access) reports on the disposal of TNT are listed in the following Refs (Refs 4, 6, 9, 19, 20 & 33)

- Refs:* 1) A.J. Clear, "The Desensitization of TNT with Sodium Sulfide", *PATR* **1495** (1945)
 2) R.M. Enzinger, "Special Study of the Effect of Alpha-TNT on the Microbiological Systems and the Determination of the Biodegradability of Alpha-TNT", *USAEHA-24017-70/71*, Army Environmental Hygiene Agency, Edgewood Ars (1970)
 3) V.I. Siele & C. Ribaud, "A Laboratory Study of an Extraction Synthesis Technique for the Elimination of Pollutants from Mahon Fog Filter Water at TNT Plants", *PATR* **4163** (1971)
 4) E.L. Grove, "Incineration of TNT and Composition B; Picatinny Arsenal Incinerator", *FLI-71-1039-4*, Freeman Labs Inc, Rosemont, Ill (1972) (Limited distrib)
 5) L.A. Spano et al, Pollut Eng Sci Solutions, Proc Int Mfg Sec Eng Sci, 1st, 288 (1972) & *CA* **78**, 163723 (1973)
 6) A.J. Tulis et al, "Technology Investigation on Mine Explosive Desensitization", Final Rept, IIT Research Institute, Chicago (1973) (Limited distrib)
 7) W.D. Won et al, *Applied Microbiology* **27** (3), 513 (1974)
 8) R.W. Traxler, "Biodegradation of α -TNT and its Production Isomers", Interim Rept July 1973 to July 1974, Rhode Island Univ, Kingston (1974)
 9) W.D. Won & R.J. Heckly, "Biodegradation of Trinitrotoluene", Final Rept for Contract N00014-69-A-0200-1001, Naval Biomed Res Lab, Univ of Calif, Berkeley (1974) (Limited distrib)
 10) M.M. Demek et al, "Studies on the Regeneration of Active Carbon for Removal of Alpha-TNT from Waste Waters", *EC-TR-74008*, Edgewood Ars, Aberdeen Prov Grnd (1974)
 11) A.J. Tulis & J.N. Keith, "Technology Investigation on Mine Explosive Desensitization", *IITRI-C6314-3*, IIT Research Institute, Chicago (1974)
 12) W. Heidelberg, Eng Bull Purdue Univ, Eng Ext Ser 145, Pt 2, 662 (1974) & *CA* **83**, 102829 (1975)
 13) B.D. Trott et al, "Design and Evaluation of a Chamber Capable of Containing the Detonation Effects of 40 Lbs of TNT", Battelle Labs, Columbus, O (1975)
 14) C.C. Andrews & J.L. Osmon, "The Effects of Ultraviolet Light on TNT in Aqueous Solutions", *WOEC/C-75-197*, Naval Weapons Support Center, Crane, Ind (1975)
 15) R.W. Traxler et al, *DevIndMicrobiol* **16**, 71-76 (1975) & *CA* **87**, 18753 (1977)
 16) R.E. Klausmeier et al, ProcIntBiodegradation Symp, 3rd, 799 (1975) & *CA* **87**, 103974 (1977)
 17) B.W. Stevens et al, "Explosives Removal from Munitions Wastewaters", Army Natick Dev Cent, Natick, Mass (1975) & *CA* **84**, 184538 (1976) (AD-A015602)
 18) D.C. Heberlein, "Chemical Neutralization of Trinitrotoluene", Army Mobility Equipment R&D Command, Fort Belvoir (1976)
 19) A.F. Tatyrek, "Treatment of TNT Munitions Wastewaters—The Current State of the Art", *PATR* **4909** (1976) (Limited distrib)
 20) A.J. Tulis et al, "Delivery System for Chemical Neutralization of Land Mines", *IITRI-C6325-10*, IIT Research Inst, Chicago (1976) (Limited distrib)
 21) K.A. Conley & W.J. Mikucki, "Migration of Explosives and Chlorinated Pesticides in a Simulated Sanitary Landfill", *CERL-TR-N-8*, Army Construction Engrg Res Lab, Champaign, Ill (1976) & *CA* **86**, 126714 (1976)
 22) K.K. Jain, "Laboratory Study on Feasibility of Munitions Wastewater Treatment by Adsorptive Oxidations", Re-Entry Environ Syst Div, General Electric Co, Philadelphia (1976) & *CA* **85**, 130071 (1976) (AD-A020744)
 23) Y. Okamoto et al, "The Removal of 2,4,6-Trinitrotoluene (TNT) from Aqueous Solutions with Surfactants", *ARLCD-TR-77038*, US

ARRADCOM, Dover (1977) & CA 89, 79720 (1978) 24) J. Epstein et al, "Environmental Quality Standards Research of Wastewaters of Army Ammunition Plants", **ARCSL-TR-77025**, US ARRADCOM, Chem Syst Lab, Aberdeen Prov Grnd (1977) 25) R.K. Andren et al, *Ind Wastes (Chicago)* 23 (2), 28 (1977) & CA 87, 87908 (1977) 26) V.L. Zolotov et al, *USSR Pat* 432764 (1977) & CA 87, 106558 (1977) 27) D. Bhattacharyya et al, *JWater-PollutControlFed* 49 (5), 800 (1977) & CA 87, 72868 (1977) 28) T.C. Castorina et al, "Compatibility of Flocculating Agents with RDX/TNT/Comp B", *PicArns*, Dover (1977) & CA 87, 72840 (1977) (AD-A035136) 29) C.C. Andrews, R.E. Klausmeier & J.L. Osmon, *USP* 4038116 (1977) & CA 87, 154310 (1977) 30) C.C. Andrews & J.L. Osmon, "The Effects of UV Light on TNT and Other Explosives in Aqueous Solutions", **WQEC/C-77-32**, Weapons Qual Eng Cent, Nav Weapons Support Cent, Crane, Ind (1977) & CA 87, 55279 (1977) (AD-A036132) 31) F.W. Parrish, "Fungal Transformation 2,4-Dinitrotoluene and 2,4,6-Trinitrotoluene", *ApplEnvironMicrobiol* 34 (2), 232 (1977) & CA 87, 195528 (1977) 32) J.L. Osmon & C.C. Andrews, "The Biodegradation of TNT in Enhanced Soil and Compost Systems", **ARLCD-TR-77032**, US Army ARRADCOM, Dover (1978) 33) R.E. Klausmeier, "The Science Behind Composting of Explosives", paper presented at Safety, Pollution Abatement and Conservation of Energy Review, US Army ARRADCOM, Dover (1978) 34) J.M. Szachta, "Analysis of Carbon Versus Resin", **ARCSL-TR-78103**, US Army ARRADCOM, Chem Systems Lab, Aberdeen Prov Grnd (1978) 35) Y. Okamoto et al, "Removal of Trinitrotoluene from Aqueous Media", *USP* 4073726 (1978) & CA 88, 176772 (1978) 36) K.K. Jain, *GerP* 2803789 (1978) & CA 89, 135268 (1979) 37) M. Roth & J.M. Murphy, Jr, "Ultraviolet-Ozone and Ultraviolet-Oxidant Treatment of Pink Water", **ARCLD-TR-78057**, US Army ARRADCOM, Dover (1978) 38) J.D. Hoffsommer et al, "Biodegradability of TNT: A Three-Year Pilot Plant Study", **NSWC/WOL-TR-77-136**, Naval Surface Weap Cent, Silver Spring (1978) 39) D.F. Carpenter et al, *Applied & EnvironmentalMicrobiology* 35 (5), 949 (1978) 40) R. Scola & J. Santos,

"Fluid Bed Incinerator for Disposal of Propellants and Explosives", **ARLCD-TR-78032**, US Army ARRADCOM, Dover (1978) 41) E. Leitis & J.D. Zeff, "UV-Ozonization of Organic Compounds in Water", paper presented at ACS mtg, Ind & Engrg Chem Section, Honolulu (April 1-6, 1979) 42) F.C. Farrell, J.D. Zeff, T.C. Crase & D.T. Boylan, "Development Effort to Design Pink Water Abatement Processes" (no further info)

Safety and Toxicity

As noted in the preceding discussion of "Sensitivity Data", TNT is comparatively insensitive and safe to handle. Consideration of the compilation of accident data (Ref 3) in Table 10 leads to the same conclusion. It is also noted that no one area is especially accident prone. The incident involving the expln of 10000 lbs is discussed in the section on "Preparation"; portions of the plant were redesigned as a result. A Safety Data Statement (Ref 2) summarizes factors pertinent to its handling, shipping and use

TNT is considered moderately toxic overall (Ref 1); and highly toxic when inhaled or ingested (Ref 2). The toxicity of TNT is discussed more fully in this Vol under "Toxicology of Explosives and Propellants"

Refs: 1) N.I. Sax, "Dangerous Properties of Industrial Materials", Reinhold, NY (1968) 2) Anon, "Major Component Safety Data Statement No 33, TNT", *ARCOM Supplement 1 to AMCR 385-17*, *PicArns*, Dover (8 Dec 1977) 3) H.S. Napadensky, R. Joyce, R. Rindner & D. Satriana, "Development of Hazards Classification Data on Propellants and Explosives", US Army ARRADCOM, Dover (1978)

Composite Explosives

The low melting point (ca 81°) and excellent thermal stability of TNT makes it suitable as a carrier for melt-loading more powerful expls (eg, RDX, HMX), which alone are not amenable to such efficient operation because of their high melting points. Some of these composite expls are listed in Table 11. Amm nitrate has been added to stretch the available supply of TNT, but this was no limitation to the USA in WWII, since the supply was unlimited. Al was added in some cases to obtain enhanced blast effect. Be-

Table 10
Accidents Involving TNT

<u>Process</u>	<u>Amount</u>	<u>Injuries*</u>	<u>Operation</u>	<u>Type of Output</u>	<u>Probable Cause</u>
Pressing	1/2 lb	3	Plunger-die matrix	Explosion	Misalignment causing frictional initiation
Pressing	—	—	Press	Explosion-fire	Metal-to-metal contact
Pressing	16 grains (flake)	0	Stokes pellet	Explosion	Friction from foreign metal
Pressing	—	—	Press	Explosion-fire	Frictional initiation of expl dust by slipping pulley
Casting	Residual contaminate	0	Melt reservoir	Fire	Residual TNT exposed to 220°F for 9 hrs, then impacted
Casting	Residual TNT on floor	1	Melt chamber	Fire	Frictional initiation due to scrapping of dry TNT residual on concrete floor with steel spatula
Casting	—	0	Melt tank	Fire	Friction or spark initiation during removal of old TNT-contaminated insulation during maintenance
Manufacture	10000 lbs	6 major; 100 minor	Nitrator-separator	Explosion (70 ft crater)	Thermal instability; inadequate mixing due to obstruction of agitator with hose
Manufacture	—	0	Trinitrator	Fire	Thermal instability; faulty operation
Manufacture	—	3	Dinitrator	Violent Reaction	Exothermic reaction

*No fatalities occurred in any of these accidents.

cause of its excellent brisance and blast effect, Composition B has retained the position it achieved in WWII as the most important bomb-charge expl. The properties of many of these are given in detail in the ref cited in Table 11. For the manufg procedures used, see the article on "Loading and Fabrication of Explosives", Vol 7, L46-L ff

TNT has two unfavorable characteristics which have led to problems in the production and use of melt-poured composites. Molten TNT undergoes an 11% contraction in volume during solidification, possibly forming objectionable cracks and voids in the loaded shell. This process is facilitated by the strong tendency of the melt to supercool, with the resulting undesirable formation of large crystals. These

problems are discussed under "Physical Properties", subheading "Crystallization Data". Another troublesome property of TNT is its ability to form low-melting eutectics with impurities, leading to exudation. This is discussed below. Other (limited-access) reports on melt-pouring and on prepg TNT composites are listed by title in the refs

Cavitation in the shell can also result from the foaming of molten TNT containing a small amount of adventitious grease. This problem can be overcome by adding a suitable wetting agent (Ref 3)

Exudation

Exudation in shells loaded with TNT is reviewed in Vol 6, E504-R ff. It is pointed out that the principal causes are the presence of

Table 11
Principal Composite Explosives Containing TNT

Composition (%)		Designation	Use	Refs	
TNT	Other Ingredients			Encyc Vol, pg	Other
25-35	65-75 RDX	Cyclotol	Bombs	Vol 3, C478-L	22
36-40	60-64 RDX	Composition B, B-2, B-3, B-4	Bombs	Vol 3, C478-R	22
67.8	17.5 RDX; 14.7 Plasticizer-Binder	LVD (Low Velocity Dynamite)	Demolition	—	7
40	20-30 RDX; 30-40 Amm nitrate	Amatex	Projectiles, Bomblets	Vol 1, A157-R	—
20-60	40-80 Amm nitrate	Amatol	Shells	Vol 1, A158-L	—
80	20 Al	Tritonal	Bombs	Vol 1, A146-L & in this Vol	—
42-48	38-42 Amm nitrate; 10-20 Al	Minol	Bombs, Depth Charges	Vol 8, M135-R	—
12-67	22-72 Amm nitrate; 11-32 Al	Ammonal	Bombs, Mines	Vol 1, A287-L	—
40	42 RDX; 18 Al	Torpex	Bombs, Mines	Article on Torpex in this Vol	—
40	21 RDX; 21 Amm nitrate; 18 Al	DBX	Depth Charges	Vol 3, D19-L	—
25-30	70-75 HMX	Octol	Shells, Bombs	Vol 8, O6-R	22
39	49 HMX; 22 Al	HTA-3	Shells, Bombs	Vol 7, H176-L	—

impurities in the TNT, and the use of alcohol for cleaning the shell threads or as an ingredient of the shellac used in the booster cavity. The lab data implicating alcohol as a cause of exudation was obtained at PicArns about 1920, and is apparently no longer available. Since it appears unlikely that small amounts of alcohol would cause exudation under modern conditions, it seems desirable to check this question exptly. Alcohol is in fact used for this purpose at Navy installations

Exudation tests are described in Vol 6, E507-R. One now used involves tightly wrapping a 1"x5" casting of the expl sample with Whatman No 1 filter paper and sealing it hermetically in a heavy-walled Al cylinder. The sample is then held at 71° for 6 days. The exudate absorbed by the paper is measured. Military grade TNT

typically shows 0.6 to 1.2%, or more exudate. A typical analysis of exudate from specification-grade TNT, made in 1973 at the Radford Army Ammo Plant by the continuous process, is as follows:

2,4,6-TNT	88.19%
2,3,4-TNT	1.99
2,4,5-TNT	0.67
2,4-DNT	7.65
2,6-DNT	0.98
2,5-DNT	0.19

Not shown in the above analysis are two other impurities present in military-grade TNT to the extent of about 0.1 to 0.5% each: hexanitro-bibenzyl (HNBB) and methylpentanitrodiphenyl-methane (MPDM). The chemistry of these materials is discussed more fully in the section on "Unsymmetrical Isomers" which follows.

These compds, as well as the DNT and unsymmetrical TNT isomers, all form, with 2,4,6-TNT, low-melting eutectics which exude, as mentioned under "Physical Properties"

Two approaches have been considered for minimizing exudation: production of TNT with reduced quantities of impurities, and adding materials which absorb the eutectics. Removal of the Dinitrotoluenes, a major cause of exudation (as shown in the above analysis), can be effected by using more drastic nitration conditions which, of course, adds to process cost. The Dinitrotoluenes are not removed by the conventional purification method ("selliting"), but they are removed by recrystn from nitric acid — a procedure used only on a very limited scale since it is considered less economical than selliting. The formation of HNBB and MPDM can be minimized by more precise selliting — ie, using a more exact dosage at lower pH (see discussion under "Purification")

The addition of small amounts (ca 0.6%) of cellulose esters removes exudate by absorption, and also reduces the tendency to crack (Ref 17); polyurethanes remove exudate and double the compressive strength of the case (Ref 8), or impart finer crystal structure to the TNT matrix (Ref 33). Exudation is also discussed in a limited-access report (Ref 11)

Refs: 1) R.W. Scharf, "Develop Cast TNT Demolition Block", PATR 1285 (1943) (Limited distrib) 2) L.H. Eriksen, "Properties of 70/30 Cyclotol", PATR 1476 (1944) (Limited distrib) 3) A.J. Clear, "Cause and Prevention of Frothing of Molten TNT", PATR 1553 (1945) (Limited distrib) 4) R.B. Herring et al, "The Grist-Viscosity Relationship in RDX-TNT Mixtures", HDC-20-T-1-Ser-B, Holston Defense Corp, Kingsport, Tenn (1949) (Limited distrib) 5) R.B. Herring & B.L. Beard, "The Pilot Plant Production of Low-Apparent Viscosity 75/25 Cyclotol", HDC-20-T-7-Ser-B, Ibid (1950) (Limited distrib) 6) R.B. Herring et al, "The Apparent Viscosity of RDX-TNT Mixtures, its Determination and Control", HDC-20-T-9-Ser-A, Ibid (1951) (Limited distrib) 7) W.H. Voigt, PATR 2374 (1957) 8) W.H. Voigt, USP 3447980 (1969) 9) R.P. Parker & B.W. Thorpe, "The Phase Diagram of the RDX/TNT System", DSL-TN-140, Defence Standards Labs, Maribyrnong, Australia (1970) (Limited

distrib) 10) F.C. Rauch & W.P. Colman, "Studies on Composition B", Final Rept, American Cyanamid Co, Stamford (1970) (Limited distrib) 11) W.H. Voigt, "Use of Thermoplastic Additives to Control Cracking and Exudation of Cast TNT Explosives", PATR 3829 (1970) (Limited distrib) 12) W.P. Colman & F.C. Rauch, "Studies on Composition B", Final Rept, American Cyanamid Co, Stamford (1971) (Limited distrib) 13) W.H. Andersen & R.R. Randall, "A Feasibility Study of Explosive Melt-Load Process Improvement by the Use of Dielectric and Microwave Energy Concepts. Phase II. Test Model", Rept SHI-3100-12, Shock Hydrodynamics Inc, Sherman Oaks, Ca (1971) (Limited distrib) 14) Anon, Engrg Des Hndbk, "Properties of Explosives of Military Interest", AMCP 706-177 (1971) 15) H.W. Koch & H. Freiwald, "Rheological and Other Properties of Suspensions of RDX in Molten TNT (Part I)", FSTC-HT-23-1340-71, Army Foreign Sci & Technol Center, Charlottesville, Va (1972) (Limited distrib) 16) Ibid, "Ibid (Part II)", FSTC-HT-23-1341-71, Ibid (1972) (Limited distrib) 17) W.H. Voigt, L.W. Pell & J.P. Picard, USP 3706609 (1972) 18) T. Caggiano, "Calculation of TNT Air-Blast Equivalences for Surface Blasts", PATR 4567 (1973) 19) R.S. Kukuvka & K. Gandhi, "Propagation Tests of 55-Pound Boxes of Bulk TNT and 60-Pound Boxes of Bulk Composition B", PATR 4622 (1973) (Limited distrib) 20) J. Edelmaier, "Makeshift Processing of Trinitrotoluene", FSTC-HT-23-0225-75, US Army Foreign Sci & Technol Center, Charlottesville, Va (1974) (Limited distrib) 21) R.G. Hunt & T.A. Groce, "Hazard Analysis of Continuous Melt-Pour System", Rept A0258-740-03-010, Herc-74-6, Allegheny Ballistics Lab, Hercules, Inc, Cumberland, Md (1974) (Limited distrib) 22) B.M. Dobratz, "Properties of Chemical Explosives and Explosive Simulants", UCRL-51319, Rev 1, Lawrence Livermore Lab, Livermore (1974) 23) G.R. Gibson & R.L. Dickenson, "Study of Trinitrotoluene Exudates", RAD 240.10, Radford Army Ammo Plant (1974) (Limited distrib) 24) W.H. Voigt, "Pressed Explosive-Coated RDX for Shock Resistance: 91/9 RDX/Modified TNT", PATM 2188 (1975) (Limited distrib) 25) J.S. Wilkes, Jr et al, "Thermal Decomposition of AMATEX

and Related Materials. Part I", Rept **FJSRL-TR-75-0008**, Frank J. Seiler Res Lab, US Air Force Academy, Col (1975) (Limited distrib)

26) E.J. Flaherty et al, "Octol Explosive: Investigation of Exudation and Growth", **PATR 4705** (1975) (Limited distrib)

27) W.H. Ng, "Pumping of Molten High Explosives (TNT and Composition B)", **PATR 4849** (1976) (Limited distrib)

28) J. Chazal, "Report of Compatibility Study Between TNT/Aluminum and Polyester", Rept **AST-18501-015-76, FSTC-0346-76**, Army Foreign Sci & Technol Center, Charlottesville, Va (1976) (Limited distrib)

29) A. Wilderman & J.A. Mavec, "Detonation Trap Development Studies", IIT Res Inst, Chicago (1977) (Limited distrib)

30) W.T. Jones et al, "High Explosives Data Manual", **RARDE Tech Rept 5/78**, Royal Armament R&D Establishment, Fort Halstead, Kent, Engl (1978) (Restricted distrib)

31) B.E. Brokenbrow et al, "The Effect of Explosives and Propellants on Some Thermoplastics and Rubbers, Part 2", **ERDE-TR-5**, Expls R&D Establishment, Waltham Abbey, Engl (no date) (Limited distrib)

32) Ibid, "Ibid, Part 3", **ERDE-TR-29**, Ibid (no date) (Limited distrib)

33) W.H. Voigt, USP pending (no date)

Unsymmetrical TNT Isomers

Of the six possible TNT isomers, five are unsymmetrical, or "meta", isomers. Their structures and melting points are given below in Table 12 in comparison with the symmetrical (2,4,6-) isomer (see structural formula in the introduction):

The unsymmetrical isomers all differ from the 2,4,6-isomer in having notably higher mp's, and in having one nitro group which is easily replaced by treatment with various nucleophilic reagents; the position of this group is indicated in Table 12. Consequently, the reactions under basic conditions of 2,4,6-TNT are entirely different from those of the other five isomers. All of the unsymmetrical isomers have been found in crude TNT, ranging from about 2.5% for 2,4,5- and 1.5% for 2,3,4- down to 0.006% for 3,4,5- (see "Purification"). The extent to which the properties and reactions of the isomers have been studied roughly parallels their occurrence in crude TNT - most of the work being on the 2,4,5- and 2,3,4- compds and comparatively little on the others

Improved procedures have been developed for the prepn of all of the isomers (Ref 13) and of some of the required intermediates (Ref 15). A gas-chromatographic analytical procedure is available (Ref 13). Mass spectra have been published for all the isomers (Ref 10). In all cases, initial reaction in obtaining the spectrum involves interaction between the methyl group and an adjacent nitro group, except in the case of the 3,4,5-isomer, which lacks this requirement. The isomers can be separated from each other by adsorption chromatography over silica gel (Ref 16), or by treatment of the mixt with aq urea (Ref 14). They are poorly soluble in water, but easily soluble in acetone, diethyl ether, and aromatic hydrocarbons. The 2,4,5-isomer can be purified by recrystn from abs ethanol, all of

Table 12
TNT Isomers

Isomer	M.P. (°C) (Ref 13)	Position of Reactive Nitro Group	Deflagration Temp (°C) (Ref 1)	
			Pure	With Na ₂ CO ₃
2,4,6 (α)	80.9	(None)	281-300	-
2,3,4 (β)	110-111	3	301-303	208-215
2,4,5 (γ)	104-104.5	5	288-293; 290-310	191-198
3,4,5 (δ)	133-134	4	305-318	252
2,3,5 (ϵ)	96-97	2	333-337	268-271
2,3,6 (η)	111.5-112.5	3 (?)	327-335	249-250

the others from methanol (Ref 13); it exhibits polymorphism (Refs 4, 5 & 12)

Thermochemical data are available (Ref 2) on the heats of combustion and formation for all five isomers, on the heats of nitration from various Dinitrotoluenes for the 2,3,4-, 2,4,5-, and 2,3,6-isomers, and on the heats of crystn for the 2,3,4- and 2,4,5-isomers. Data are also available (Ref 1) on the shock sensitivities of all of the isomers except 2,3,6-, and on the rates of decompn at 140° of the 2,3,4-, 2,4,5-, and 2,3,5-isomers. The detonation pressure and the temp coefficient of decompn between 140 and 180° have been measured for the 2,4,5-isomer

2,3,4- and 2,4,5-TNT form addition compds ("π-complexes") at 1:1 molar ratio with several polycyclic aromatic hydrocarbons (naphthalene, acenaphthene, fluorene, phenanthrene and anthracene) (Ref 2). 2,4,5-TNT forms complexes with 4-aminozaobenzene, 4-aminoacetophenone, bis (2-hydroxyethyl) amine, and tris (2-hydroxyethyl) amine (Ref 1). The first two have a 1:1 molar ratio, the third 1:2, and the fourth 2:1. Upon heating, the two 4-amino compds react with replacement of the 5-nitro group, as discussed below

All of the unsymmetrical TNT isomers react with nucleophilic reagents with selective replacement of the labile nitro group located in the position indicated in Table 12. The 2,3,6-isomer may react in this way, but the position of the reactive group has not been established with certainty, and early work even suggested that a mixt of compds is formed (Ref 1)

The reaction with Na sulfite (Ref 2), in which the reactive nitro group is replaced by the Na sulfonate moiety, is of great practical importance for the purification of crude TNT (see "Purification"). This reaction has been used for lab prepn of the corresponding sulfonates from the 2,3,4- and 2,4,5-isomers (Ref 17), and the reactions and derivatives of the sulfonates have been studied. Amm and Mg sulfites react similarly

Largely on the basis of study of the nucleophilic reactions of the 2,4,5- and 2,3,4-isomers (Refs 1, 6, 8 & 17), it has been found that many different substituents can be introduced. Some of these are as follows, the reagent used being given parenthetically: RNH-(RNH₂, where R can be H-, NH₂-, C₆H₅NH-, NC-, H₂NCONH-, aliphatic, cycloaliphatic, aromatic, monoamino-

aromatic, or derived from an amino acid), RR'N- (RR'NH, where R and R' are both aliphatic), HO-(NaOCl, NaCN, NaNO₂, NaHCO₃ or NaOCOCH₃), Cl-(POCl₃), RO-(NaOR), RS- (RSNa, where R is phenyl or R'C(S)-), and N₃-(NaN₃). Reaction with Na₂PO₂S₂ yields bis (4,6-dinitro-m-tolyl) sulfide (Refs 6 & 8), while Na₃PO₃S or H₂NC(S)NHNH₂ forms the corresponding disulfide (Refs 1 & 6). Hydroxylamine does not form a derivative by simple replacement of -NO₂ by -NHOH, as formerly thought (Ref 1), but instead yields O,N-di(5-methyl-2,4-dinitrophenyl) hydroxylamine (Ref 3). The reaction of ammonia with four of the unsymmetrical isomers has been studied (Ref 19); the expected dinitrotoluidines were formed; in the case of the 2,3,6-isomer, however, an equal amount of 2-amino-3,6-dinitrotoluene was also unexpectedly obtained

The 2,4,5- and 2,3,4-isomers react with the 2,4,6-isomer in the presence of base (ie, the 2,4,6-trinitrobenzyl anion) as follows (Ref 7):

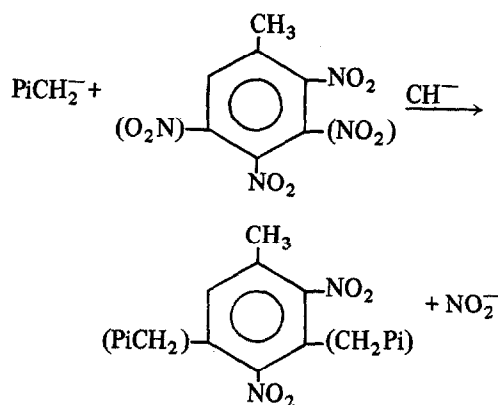

The 5-(picrylmethyl) compd ("MPDM") is formed to some extent during the purification of TNT (see "Purification"); but the corresponding 3-isomer is not formed, probably because of greater steric hindrance of the reacting nitro group

As noted in Table 13, the rates of reaction of various nucleophiles with any one TNT isomer vary widely, as do also those of individual nucleophiles with the various isomers, reactivity decreasing in the order 2,4,5-, 2,3,4-, and 2,3,6- in all cases (Ref 8). It is also of interest, in comparing

the rate constants of the 2,4,5- and 2,3,4-isomers, that these differ by a factor of only about three at most with reagents where steric hindrance is not a factor (ie, sulfite, hydroxide, methylamine, hydrazine, glycine), but that they differ by a factor of ten or more with more sterically hindered reagents (ie, pyrrolidine, piperidine). The comparatively slow rate of reaction of the 2,3,6-isomer with sulfite ion and with hydrazine has been used as the basis of a method of separating it from other isomers (Ref 1). The comparatively rapid reaction of the 2,4,5-isomer with piperidine forms the basis for a procedure for its colorimetric determination, as noted below

The 2,3,4- and 2,4,5-isomers undergo reductive denitration to 2,4-DNT at room temp in good yield with aq Na borohydride (Ref 20):

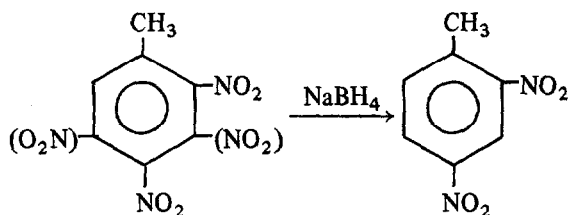

The 2,4,6-isomer reacts with reduction of the ring, and in competitive expts was found to react more rapidly than the unsymmetrical isomers

The unsymmetrical isomers resemble 2,4,6-TNT in being stable under acidic conditions. All of them have been oxidized to the corresponding carboxylic acids; chromium trioxide in sulfuric acid was used

Table 13
Rate Constants of Reactions of Nucleophiles
with Trinitroaromatic Compounds in $M^{-1} \text{ min}^{-1}$
(from Refs 6 & 8)

Nucleophile	Liters per Mole per Minute		
	2,4,5-TNT	2,3,4-TNT	2,3,6-TNT
Sulfite ion	960	480	96
Hydroxide ion	4	1.3	0.074
Pyrrolidine	550	51	4.9
Dimethylamine	126	—	—
Methylamine	23	17	0.50
Hydrazine	21	11.3, 13.8	—
Piperidine	187	5.9	3.12
Glycine	3.6	4.1	—
Alanine	—	0.2	—

All of the unsymmetrical isomers undergo characteristic color reactions in the presence of base with ketones such as acetone, butanone, or cyclohexanone (Ref 1), and with Na nitrite—N,N-dimethylformamide (Ref 6). By using an appropriate combination of reaction conditions and wavelength for measuring absorptivity, it may be possible to use the second system for automated analysis of the unsymmetrical isomers present in crude 2,4,6-TNT. The 2,4,5-isomer undergoes a rapid color reaction with piperidine of sufficient sensitivity to be of possible use for on-line monitoring in TNT production (Ref 11). Other color reactions are discussed in Vol 3, C405-L ff

The reactions of nucleophiles with TNT isomers is the subject of a restricted report (Ref 9)

Written by E. E. GILBERT

Refs: 1) Beil 5, Main Vol & 3 supplements
2) Urbański 1 (1964), 326 ff 3) A.S. Bailey et al, Tetrahedron 22, 995 (1966) 4) M.C. Chick & B.W. Thorpe, "Polymorphism in 2,4,5-Trinitrotoluene", DSL-382, Defence Standard Labs, Maribyrnong, Australia (1970) (Limited distrib) 5) Ibid, "Ibid", AustralianJChem 24, 191 (1971) 6) D.H. Rosenblatt, paper presented at Third Seminar on Nitroaromatic Chemistry, PicArns, Dover (26 Sept 1972) [nucleophiles & isomers] 7) C.D. Chandler et al, JChromatogr 67, 255 (1972) 8) D.H. Rosenblatt, "Prevention and Control of Water Pollution in the U.S. TNT Industry", Pollut Eng Sci Solutions, Proc Inst Meet Soc Eng Sci, 1st, 272-77 (1972) & CA 78, 163711 (1973) 9) D.H. Rosenblatt & W.H. Dennis, Jr, "Studies in the Reactions of Nucleophiles with TNT Isomers", EdgewoodArsTechRept 4698 (1973) (Restricted report) 10) T.F. Jenkins et al, "Mass Spectra of Isomers of Trinitrotoluene", JChemEngData 18 (4), 438 (1973) 11) L.J. Schiff, "A Colorimetric Method for the Determination of 2,4,5-Trinitrotoluene", Edgewood-ArsTechRept EC-TR-73068 (1974) 12) M.C. Chick, "Polymorphism of 2,4,5-TNT", AustralianJChem 27, 1017 (1974) 13) W.H. Dennis, Jr et al, JChemEngData 20 (2), 202 (1975) 14) V.L. Zbarskii et al, USSRPat 541837 (1975) & CA 86, 105161 (1977) 15) E.E. Gilbert & J.R. Leccacorvi, Proplnts&Expls 1, 89 (1976) 16) C. Ribando, J.R. Leccacorvi & E.E. Gilbert, US Pat Disclosure

5299, PicArsn, Dover (15 Nov 1977) [sepn of TNT isomers by chromatography] 17) E.E. Gilbert, *Proplnts&Expls* **2**, 118-25 (1977) 18) A. Alm et al, "Analysis of Explosives", *Natl Defence Res Inst, Dept 2, Stockholm, Sweden* (1978) 19) A.T. Nielsen et al, *JOrgChem* **44** (14), 2499 (1979) 20) Y. Okamoto & S.T. Attarwala, *JOrgChem* **44** (18), 3269 (1979)

Analytical

This annotated bibliography of the analytical chemistry of 2,4,6-Trinitrotoluene, alternately referred to as α -TNT or TNT, covers a period ranging from ca 1940 to the present. Over this period, the field of analytical chemistry and, therefore, that of TNT has advanced from the simple wet chemical to the automated, computerized and highly complex instrumental methods. Because of this wide spectrum of advancements, the analytical chemistry of TNT will be formatted according to the general categories of:

- I. Wet Chemical Methods
- II. Thermogravimetry
- III. Electrochemistry
- IV. Chromatography
- V. Spectrophotometry
- VI. Spectrometry

Strict adherence to such a format is not possible. The III. to VI. categories are predominantly instrumental. However, although wet chemistry predates these categories, it nevertheless pervades the most sophisticated instrumental technique to date. In addition, in some cases one of the disciplines within a category will be interfaced with one of another category, eg, GC/MS. In such cases the referenced analyses will be cited under one category and cross-referenced under the other

I. Wet Chemical Methods

The qual analysis of expl mixts containing TNT entails laborious and time consuming procedures predicated on specific knowledge of solubilities, melting points, densities and refractive indices. Procedures for the determination of these constants (Ref 21), together with some qual and quant spot test methods are compiled in a series of manuals (Ref 22). Military specifications of the physical constants for TNT are

also delineated (Ref 51), and those of TNT in various formulations, Amatol, Octol, Tetrytol, Pentolite, Tritonal, Comp B, Comp B-3, Comp B-4, Comp C-3, Comp C-4, Cyclotol, DBX, Ednatol, HBX-3, H-6, HTA-3, Minol, and MOX-2B are tabulated in an engineering design handbook (Ref 52)

Wet chemical methods of analyses of formulations containing TNT, as cited above, usually involve the application of preferential dissolution for resolving the mixt into its component parts (Ref 53). Titrimetric methods for the quant determination of the resolved components are also presented (Refs 23, 26, 11, 66 & 98)

Specific problem solving and modifications of procedures by wet chemical methods are included as recorded in the Picatinny Arsenal Laboratory Reports (PALR). Acidity values as sulfuric acid were found to be comparable with various indicators (Ref 1). The determination of percent TNT in Tetrytol by a carbon tetrachloride extraction method was shown to have an accuracy and reproducibility of ± 0.03 and 0.04% , respectively (Ref 2). A mixt consisting of TNT, Haleite (EDNA) and Cyclonite (RDX) was analyzed by extractions, $\text{CHCl}_3/\text{CCl}_4$ for TNT, $3\% \text{NH}_4\text{OH}$ for Haleite and the residue Cyclonite by difference (Ref 3). Feigl's spot test method was used for the detection of Hg contamination in TNT (Ref 5). A mixt of TNT, PETN and wax was analyzed by solvent extractions followed by titrimetry using titanous sulfate (Ref 6). The setting point of TNT determined by the inclusion of Ca chloride was found superior, requiring less time than the specification method (Ref 7). A modified Fischer method as compared to the specification method was shown to quantify the water content more accurately (Ref 10). The compositional analysis of a cast mixt of TNT/RDX/wax/Ba stearate was performed by solvent extractions followed by gravimetry (Ref 13). A titanous reduction method for the quant determination of TNT has been reported (Ref 54) and a non-aqueous titrimetric method applied to a mixt consisting of TNT, NH_4NO_3 and NaNO_3 (Ref 19)

Results are presented of various spot tests on a select number of ions and organic compds (including TNT) extracted from expln debris (Ref 99). Single component distributions in cast binary systems with a common TNT matrix

were determined by a staining method (Ref 16). Development of a detection spray reagent system for the detection of expl residues (TNT) on the exterior of letter and package bombs is reported (Ref 132). A spot test was used for TNT contamination in a powder containing NC, DNT and DBP (Ref 4). A detailed review of color reactions and related analytical procedures for the qual determination of TNT and formulations containing TNT is given in Ref 27. A compilation of analytical data on the more common expls (TNT) dealing with some color reactions are also compiled (Refs 87 & 153)

Total nitrogen of TNT in wastewater was determined by preliminary digestion with $K_2S_2O_8$ in alkaline soln and the NO_3 released was reduced by an automated Cd reduction method (Ref 133). Trinitrobenzoic acid was dissolved in water and titrated with NaOH without an indicator until a weak pink color appeared and persisted even in the presence of TNT and TNB (Ref 34). A gas comparison pycnometer used in conjunction with a Velidyne D15 differential pressure transducer with He yields a density accuracy of $\pm 0.002g/ml$ (Ref 134). The use of acetone as a solvent for 2,4,5-Trinitrotoluene causes hydrolysis of the 5-nitro group on standing. The effect is discussed in terms of the sampling factors involved and their importance in trace analysis in general (Ref 55). The chemical analysis of TNT by extraction and titration techniques, as well as by gas chromatography is reported (Ref 74). Simple chemical and instrumental procedures are given for the identification of common expls (TNT included) in post-explns (Ref 88). Titrimetry and UV analyses were used to quantify components of a mixt resolved by column chromatography (Ref 8). After treatment of wastewater samples containing TNT and its derivatives with Na sulfite-hydroxide, quant determinations were made using a spectrophotometric procedure (Ref 9)

II. Thermal Analysis

Differential scanning calorimetric methods are applied for the determination of heat of fusion, purity, specific heat and activation energy of decompn for undiluted, unmixed samples of TNT, TNB, Tetryl, RDX, HMX and PETN (Ref 28). The differential thermal analysis thermo-

grams of TNT show varying rapidity of heat feedback which is assumed to be the cause of differing exotherms observed with mixts of TNT with carborundum (Ref 35). Observations with DSC indicate polymorphic or polytypic behavior near the melting point of TNT (Ref 36). The thermal properties of TNT have also been reported by Maycock (Ref 41). Calorimetric and X-ray data show that structural changes can occur in TNT on heating and that different forms can be prepared by crystn and sublimation (Ref 37). A review is presented with emphasis on hot-stage microscopy studies of pour points of casting of TNT into artillery rounds (Ref 119). Hot-stage microscopy technique was used to determine the wetability of the TNT/RDX in Comp B by wax after solidification of TNT (Ref 154)

III. Electrochemistry

TNT was determined in the presence of DNT's by polarography in a medium containing Me_2CO , pH buffer and Na_2SO_3 (Ref 100). A review with 15 refs on the polarographic behavior of 20 expls and further developments in the field are reported (Ref 75). Applicable to both lab and field use, the single sweep polarographic technique can determine as little as 50 ppb directly from water medium (Ref 120). Pulse polarography was applied for the qual and quant analysis of trinitroglycerine in TNT (Ref 135). Polarographic analysis of some expls including TNT have been documented (Ref 38). A review of the state of development of the various instrumental methods of analysis including polarography is presented (Ref 136). Whitnack (Refs 24 & 101) also used the linear sweep polarograph to determine microgram quantities of TNT in milligram samples of warhead exudates. Brandone et al (Ref 102) determined polarographically the compn of expl mixts containing TNT

The acid/base behavior of aromatic nitro compds in DMF, Me_2CO , MeCOEt, and a mixt of solvents were studied using high frequency titration (Ref 42). $Pr_2CO/EtOH$, MeEtCO/MeOH and MeEtCO/EtOH are reported as suitable solvents for the potentiometric titration of TNT (Ref 43). Low concns of TNT in air were detected in their negatively charged state via electron transfer from ionized SF_6 . The charged

TNT was measured with an air electron multiplier producing an electric current proportional to its concn (Ref 103)

IV. Chromatography

1) Gas Chromatography (GC, GLC, VPC)

Expl detection is enhanced by preconcn on a metal surface of available expl vapor prior to its introduction into the GC detector. Adsorption by a metal surface has the additional advantage of reduced water interference, easier thermal cycling, reduced memory effects and greater durability (Ref 76). A quant GC procedure was developed to measure the output of vapor concns of TNT, 2,4-DNT and EGDN (Ref 121). Vapors of TNT were concd on chromosorb 102 at 50–70° and detected by GC (Ref 104). Exptl techniques were employed involving measurement of response of test equipment to a controlled flow of TNT vapor source and determinations made of the vapor concn by trace GC equipped with a vapor concentrator (Ref 105)

GC in conjunction with TLC was used for the quant analysis of nitro aromatic compds (TNT) in the micro- to pico-gram range using Ni-63 electron capture detector (Refs 44 & 56). Hoff-sommer also developed a GC method for the detection of TNT together with RDX and Tetryl in ppb to pp trillion in sea water (Refs 57 & 67). Isomer impurities of MNT, DNT and TNT in alpha-TNT were resolved and quantified by GC (Refs 29, 58, 59, 77, 106 & 122). A GC procedure using a flame ionization detector was developed to control product quality and study variables in the continuous TNT process (Ref 60). Products of biodegradation of TNT in a matrix of TNT were analyzed by GC using a glass column packed with Dexsil 300 on chromosorb W (Ref 140). After an expln, the base charge residue containing TNT extracted with acetone from a blasting cap was determined by GC with a Ni-63 electron capture detector (Ref 141). A mixt of TNT and 1,3-dinitrobenzene was resolved and quantified by GC (Ref 142). The GC analysis of TNT in mixts was compared to chemical analysis by extraction/titration techniques (Ref 74). Sampling factors involving GC trace analysis of TNT is discussed in terms of chemical instability in acetone (Ref 55)

A number of domestic and foreign military TNT samples were analyzed by the GC head-

space pressure of TNT and the partial pressures of several associated impurities (Ref 137). The GC headspace pressure technique was also shown to preclude the necessity for ultrapure sample, and with the electron capture detector to be sensitive to 10^{-7} torr and exptly simple (Ref 138). The vapor pressures of TNT and DNT isomers were measured by the GC electron capture technique (Ref 139)

GC indicated that 2,4,6-trinitrophenol and 3,5-dinitrophenol are formed predominantly from TNT with NaOH (Ref 89). The colorimetric method as compared to GC required less work, gave a position response for all TNT isomers, including degradation compds, and was more suitable for routine surveillance (Ref 107). GC chromatograms are compiled together with TLC data and color reactions of TNT and TNT in mixts (Ref 153). A review is presented of the state of development of the gas chromatographic technique for the analysis of expls, TNT included (Ref 136). Prototypes of on-stream process analyzers have been developed utilizing the latest technological advances in physicochemical sensors and instrumentation (GC) for the detection and measurement of the process control parameters in the manuf of TNT (Ref 123). The more advanced instrumental methods of analysis, including GC, for the detection and identification of expls are presented (Ref 90)

Pyrolysis of expls in tandem with GC/MS was used for the identification of contaminant expls in the environment (Ref 108). Isomer vapor impurities of TNT were characterized by GC-electron capture detector and mass spectrometry (Ref 61). Volatile impurities in TNT and Comp B were analyzed using a GC/MS; the GC was equipped with electron capture and flame ionization detectors (Ref 79). The vapors evolved from mines, TNT, acetone, toluene, cyclohexanone and an organosilicon, were analyzed by GC/MS (Ref 78). Red water produced by the sellite purification of crude TNT was analyzed by GC/MS for potentially useful organic compds, 2,4-dinitrotoluene, 3- and 4-sulfonic acids (Ref 124). Various reports were surveyed to determine which methods, including GC/MS, are potential candidates for detection of traces of TNT vapors emitted from land mines; factors influencing transportability of TNT vapors thru soil to soil/air interface are dis-

cussed (Ref 80). Impurities contained in TNT were analyzed by a GC equipped with a FI detector and interfaced with a MS; spectra were recorded on photoplates and processed by a computer system (Ref 62). A GC method was studied for the detection and identification of post-expln gas phase residues (Ref 118a). GC was used to support work on enzymatic action on TNT to produce photons at 492nm, detected photometrically at the pp trillion level (Ref 155). Wastewaters from the Army manuf of TNT were characterized by GC/TLC and found to contain more than 40 organic compds derived from TNT and its isomers (Ref 156). GC in combination with TLC and spectroscopic methods has been reported (Ref 143) for the identification of post-expln residues

2) Thin Layer Chromatography (TLC)

Two dimensional TLC was used to identify impurities derived from TNT in Comp B (Ref 157). Micro-quantities of TNT impurity in DNT were determined with fine-grained (2.5–10 μ) silica gel on microplates (Ref 30). TLC separations of all major impurities formed during the purification step (Ref 45), and from various steps of the continuous TNT process are reported (Ref 68). Development of thin-layer chromatograms of impurities in TNT was achieved by direct incorporation of a zinc reductor in the thin-layer material (Ref 25). Organic expl residues, eg, TNT, were detected by TLC utilizing a combination of R_f values and color development (Ref 109). High expls having the same R_f values on thin-layer chromatograms and difficult to separate were readily resolved as their colored complexes with aromatic amines (Ref 63). The identity of 21 compds, including nitrotoluenes, was achieved by TLC using 6 solvents with 4 spray reagents (Ref 110). Traces of TNT and other expls adhering to surrounding objects after an expln can be detected and identified by TLC in combination with initial UV, followed by chemical visualization (Ref 46). A quant method of analysis for polynitroaromatics (TNT and its isomers included) in complex mixts by combination of TLC with visible spectrometry is described (Ref 31). A short column containing porous polymer beads was used to collect expl vapors of TNT, followed by TLC analysis of post-expln debris (Ref 125)

A TLC/GC procedure was developed for

determining TNT and other expls in ocean floor sediment (Ref 56). A TLC method is employed for the detection and identification of post-expln solid residues (Refs 143 & 154). TLC was used together with GC and HPLC to support work on enzymatic action on TNT (Ref 155). Wastewaters from Army manuf of TNT were characterized by TLC/GC (Ref 156). The more advanced aspects of TLC, such as high performance 5 micron size, C18 silica gel with UV-fluorescence indicator, was used for the detection of expl residues (Ref 90). Data on TLC and color reactions of TNT in mixts are furnished (Ref 26). Purification by-products in the manuf of TNT by the continuous process were identified by TLC in conjunction with IR and NMR (Ref 69)

3) High Performance Liquid Chromatography (HPLC, LC)

The analysis of TNT in wastewaters is made simple and direct by LC using a UV detector at 220nm (Refs 81 & 158). An LC method suitable for the low level determination of Tetryl in the presence of TNT, RDX and HMX is described (Ref 91). The adsorptive LC of TNT was demonstrated using poly(styrene-divinyl benzene) adsorbent and ethanol as the moving phase (Ref 112). HPLC was used for the separation of TNT from purification by-products of hexanitro-bibenzyl (Ref 69). Enzymatic action on TNT was supported by HPLC (Ref 155). HPLC chromatograms of TNT are included, together with data on TLC and color reactions of TNT in mixts (Ref 153). Pollutants in wastewater effluents containing TNT were resolved by HPLC and quantified (Ref 82). Micrograms, 30 to 40, of resolved fractions by HPLC were concd onto 6mg of KBr and examined by IR (Ref 83). HPLC and CI/MS were used in the isolation and identification of expl residues (Ref 144)

4) Column Chromatography

Components of an expl mixt containing TNT were resolved by column chromatography and quantified by titrimetric and UV analyses (Ref 8). The mixt of products of thermal decompn of TNT were resolved by column chromatography (Ref 47)

V. Spectrophotometry

A spectrophotometric analysis is described

of water effluent from carbon columns processing pink water on a continuous real-time basis down to 0.1 ppm of TNT (Ref 159). The TNM impurity in TNT was determined spectrophotometrically at a sensitivity level of 0.005% (Ref 48). The spectra of 1:1 charge-transfer complexes of diamines with TNT were generated and methods developed for determining TNT in the presence of Hexogen, Octagen and waxes (Ref 145). A spectrophotometric procedure for the quant analysis of TNT in derivatives of TNT after sulfite-hydroxide treatment of wastewater samples is reported (Ref 9). UV analysis was used for the detection and quant determination of TNT in a formulation (Ref 8). UV spectroscopy was employed for the identification of post-expln residues including TNT (Ref 143). With increasing NaOH concn, the absorption maximum of TNT exhibits a bathochromic shift (Ref 89). A prototype of on-stream UV analyzer in real time is described (Ref 123). A review of the state-of-development of instrumental methods including spectroscopic procedures is presented (Ref 48). UV, together with spectrometric methods, were applied for the characterization of TNT interaction with the surface of carbon (Ref 146). A fluorescent-dyed quarternary ammonium ion exchange resin was irradiated with UV light and the fluorescent output was monitored by a photomultiplier. In this manner, TNT was detected in wastewater at the 70ppb level (Refs 147 & 160). A literature review was conducted of aspects of bioluminescence pertinent to expl detection, including TNT, via vapor interaction with microbiological specimens (Ref 126). A biochemical approach was used to detect TNT based on two sequential chemical reactions catalyzed by specific ions producing photons read by a photomultiplier tube (Ref 161).

TNT vapor in air was determined by a colorimetric method involving a Na sulfite-hydroxide color complex (Ref 15). A method is presented for the quant spectrophotometric analysis of polynitroaromatics as their "Meisenheimer" complexes in ethylene diamine dimethylsulfoxide solns (Ref 32). Detection by formation of colored reaction complexes determined by wavelength absorbances and absorptivities of the reagent/expl samples are described (Refs 92 & 132). A semi-quant colorimetric determination

is reported of TNT in the presence of TNT and DNT isomers and checked by GC analysis for the indirect estimation of the total isomer content in the crude TNT (Ref 93). A colorimetric dual channel system was used to measure TNT among other expls in wastewater effluents at AAP's; the determination of TNT is reported to be sensitive to the 1 ppm level (Ref 127). The colorimetric method, as compared to GC, required less work, gave a position response for all TNT isomers, including degradation products, and was more suitable for routine surveillance (Ref 107)

VI. Spectrometry

1) Infrared (IR)

Constituents, including TNT in various compns, were detected and identified rapidly using IR (Ref 64). An IR method was developed for the estimation of α , β , γ -TNT and 2,4-DNT (Ref 17). A compilation of IR spectra is presented of ingredients of proplnts and expls; the IR spectra of the various isomers of TNT are included (Ref 39). The isomers of MNT, DNT, as well as TNT, determined by IR have also been reported (Refs 12, 18 & 20). Four expls, including TNT and an expl mixt containing TNT, were discriminated on the basis of the sapphire cell spectra alone (Ref 162). The presence of TNT/RDX was established in the exudates from munitions by IR and Raman spectroscopy (Ref 128). Microgram quantities of HPLC-resolved fractions containing TNT were examined by IR as micro-pellets using a beam condenser (Ref 83). IR spectra of US military and foreign samples of TNT are presented (Ref 90). IR was used for the identification of expl residues (TNT, RDX, PETN) detected at the scene of criminal bombings (Refs 143 & 129). The identification of purification by-products in the manuf of TNT was achieved by IR, together with TLC and NMR techniques (Ref 69). IR spectra of TNT are included in the compilation of other spectrograms and chromatograms (Ref 153). IR in conjunction with MS and electron spectroscopy (ESCA) was applied for the study of the interaction of TNT with the surface of carbon (Ref 146). A review is presented of the state-of-development of instrumental methods, including IR, for the analysis of TNT (Ref 136)

2) Nuclear Magnetic Resonance (NMR)

Radiofrequency resonance absorption spectroscopy techniques involving NMR, electron spin resonance, and nuclear quadrupole resonance (NQR), were investigated for the detection of specific expls, eg, TNT hidden in airline luggage (Ref 111). An NMR procedure was developed for determining low concns (0.1 to 1%) of unsymmetrical TNT isomers in crude and refined TNT (Ref 33). Non-volatile impurities in crude and refined TNT were characterized by NMR (Ref 49). NQR was used for the determination of the chemical structure, crystalline states, and morphology of TNT (Ref 148). NMR was used, together with IR and TLC, for the identification of the purification by-products in the manuf of TNT (Ref 69). NMR spectra of TNT are in the compilation of other spectral and chromatographic data of the more common expls (Ref 153). A review is presented of the state-of-development of instrumental methods, including NMR, for the analysis of TNT (Ref 136)

3) X-Ray Spectroscopy

X-ray and calorimetric data show that structural changes can occur in TNT on heating and that different forms can be prepared by crystallization and sublimation (Ref 36). Differences in the X-ray diffraction patterns of TNT were shown to be based on the method of preparation of TNT (Ref 35). Post-expln debris were examined by a Gandolfi camera, requiring but a single crystal of TNT of micron size for identification purposes (Ref 149). The X-ray diffraction patterns of TNT are included, together with those of Hexanitrostilbene (Ref 94)

4) Mass Spectrometry (MS)

An extensive and detailed coverage of the MS of expls in general has been documented (Ref 163). Volatile constituents of Comp A-3, Comp B, pressed TNT and cast TNT were surveyed with a residual gas analyzer MS (Ref 40). The mass spectra of all possible TNT (except for 3,4,5-TNT) and DNT isomers in the vapor phase were obtained as a function of ionizing voltage (Refs 65 & 84). The use of membrane inlet systems for the separation of TNT vapor in trace vapor detection is described and an analysis of the membrane inlet system for quadrupole mass spectroscopy is presented (Refs 95 & 113). Estimations of the vapor pressure of TNT were made mass spectrometrically in the range of 50–

143° by the Knudsen method, making possible the determination of concns of TNT in air as a contaminant (Ref 14). The use of MS for the in situ detection of TNT in air was studied; the lower limit of detection is reported to be 5×10^{-14} volume parts of TNT (Ref 150). Trace elemental impurity profiles of TNT from various AAP's were related to their source of origin using a double focusing spark source MS, complemented with atomic absorption spectrometry (Refs 90 & 114). MS, together with electron spectroscopy (ESCA), was used for the characterization of TNT interaction with the surface of carbon (Ref 146). A review of the mass spectrometric techniques for the analysis of expls is presented by Yinon (Ref 136). MS spectra of TNT are included in the compilation of other spectral and chromatographic data of the more common expls (Ref 153). In addition, the mass spectra of TNT have been reported by other investigators (Refs 50, 70 & 130)

5) Mass Spectrometry Interface with Gas Chromatography (GC/MS)

The pyrolysis products of expls in tandem with GC/MS served as indirect identification of contaminant expls in the environment. The pyrolysis products generated, which are indicative of the parent molecule, are separated by GC and identified by MS (Ref 108). Red water produced by the sellite purification of crude TNT was analyzed by GC/MS for potentially useful organic compds, 2,4-DNT, 3- and 5-sulfonic acids (Ref 124). The enhanced detection of TNT vapors was achieved by preconcn on a metal surface, and flash-desorbed onto a chromatograph interfaced with a quadrupole MS (Ref 76). Vapors of TNT, acetone, toluene, cyclohexanone, and an organosilicon were detected and identified by GC/MS (Ref 78). Various reports were surveyed to determine which methods, including GC/MS, are potential candidates for the detection of traces of TNT emitted from military land-mines (Ref 80). The vapors collected from Comp B were analyzed by GC/MS; besides the TNT and RDX, H₂O, N₂O, CO₂, plus several unidentified compds, were detected (Ref 79). By the use of GC, isomeric impurities in the vapor, as well as solid phase of TNT, were resolved and identified by MS (Refs 61, 62 & 115)

6) Negative-Ion Mass Spectrometry (NIMS)

The detection of TNT in trace vapor quantities was demonstrated by NIMS to be sensitive (1 ppm) and selective (Refs 71 & 72). TNT was analyzed using an electron probe to produce a negative charge on TNT, followed by quadrupole MS with SF₆ as a diluent (Ref 73)

7) *Plasma Chromatography Mass Spectrometry (PCMS)*

Due to the extremely electronegative character of nitroaromatics, eg, TNT and its isomers, and their large cross section to charge-transfer and ion-molecule reactions, negative ion plasma chromatography MS has been found particularly suitable for their detection and identification (Ref 116). TNT was detected in air at 10pp trillion (mol/mol) with PCMS as a function of carrier gas flow (Refs 96 & 164). The detection of TNT vapors with an ion mobility spectrometer, a type of PCMS, is described, together with other methods of detection (Ref 85). The detection of TNT vapors by PCMS and EIMS have been evaluated and found to be limited by the lack of portability of TNT vapors thru barrier materials (Ref 86). The PCMS was found to be ideally suited for expl vapor detection, operating at atm pressure, and responding to nitrating compds such as TNT and DNT (Ref 151)

8) *Chemical Ionization Mass Spectrometry (CIMS)*

A CIMS was used for the detection of TNT/DNT vapors in ambient air with a detectability limit of 0.06 nanogram/m³ (Ref 150). CIMS was used for the identification of expls as a function of reagent gases; TNT was identified by CIMS in a post-expln residue (Ref 131). The CI/EI spectra of ten derivatives of TNT have been reported (Ref 165). The use of methane as a reagent gas generates a CI mass spectra of TNT with a predominant M⁺¹ ion which facilitates identification (Ref 166). CIMS of TNT with hydrogen as reagent gas produces ions of low abundance from the ensuing ion-molecule reactions and, as such, confirm molecular weights (Ref 97). The CIMS fragmentation patterns of civilian and military expls were shown to be sensitive to source temp and pressure of reagent gas (Ref 117). NH₃ reagent gas was used for the CIMS identification of expl residues (Ref 144)

Components of technical grade mixts of expls were identified by field desorption MS via their intense molecular ions or protonated molecules

and structurally significant fragmentations (Ref 152)

Concns in air of various expls, including TNT, were measured by means of isotope dilution using field ionization mass spectrometry to measure the relative abundance ratios (Ref 118)

Written by T. C. CASTORINA

Refs: 1) A.J. Clear, "Comparison of Cresol Red and Phenolphthalein Indicators for Determination of Acidity in TNT", **PALR 101659**, PicArsn, Dover (1944) 2) J.C. Kolodny, "Carbon Tetrachloride Extraction for Determining TNT in 75/25 Tetrytol", **PALR 102156**, PicArsn, Dover (1944) 3) E.F. Reese, "A Quantitative Analysis of a High Explosive Mixture Consisting of TNT, Haleite and Cyclonite", **PALR 105778**, PicArsn, Dover (1944) 4) F.F. Macy et al, **PALR 102805**, PicArsn, Dover (1944) 5) I.P. Hammer, "Determination of Mercury Contamination in TNT", **PALR 112013**, PicArsn, Dover (1945) 6) L. May, "A Quantitative Method of Analysis for a Mixture of PETN, TNT and Wax", **PALR 109663**, PicArsn, Dover (1945) 7) J.C. Kolodny, "Determination of the Setting Point of TNT by a Method Involving the Use of Calcium Chloride", **PALR 115435**, PicArsn, Dover (1945) 8) L. May, "Detection and Quantitative Determination of Components of a Mixture of TNT, Picric Acid and Dinitrophenol", **PALR 116173**, PicArsn, Dover (1945) 9) C.C. Ruchhoft & W.G. Meckler, "Colored Derivative and Alpha-TNT in Colored Aqueous Alpha-TNT Solutions", **I&EC 17 (7)**, 430-35 (1945) 10) J.C. Kolodny & D. Shelton, "Determination of Moisture Content in TNT by Use of Fisher's Reagent", **PALR 118897**, PicArsn, Dover (1946) 11) F.L. English, **AnalChem 20**, 745 (1948) 12) F. Pristera, "Exudate TNT", **PALR 126558**, PicArsn, Dover (1948) 13) M. Baer, "Cast TNT/RDX/Wax/Barium Stearate", **PALR 126429**, PicArsn, Dover (1949) 14) G. Edwards, "The Vapor Pressure of 2,4,6-Trinitrotoluene", **TransFaradSoc 46**, 423 (1950) 15) M. Baer, "Determination of TNT in Air", **PALR 136084**, PicArsn, Dover (1951) 16) F. Pristera, "Method for Staining Cyclotols, Ednatols, Pentolites and Picratols for Observation and Study of the Non-TNT Phase", **AnalChem 24**, 1216 (1952) 17) D.H. Gouch, S. Singer & H.J. Gryting, "Determination of the

- Impurities in TNT", Rept **D-1086-FR-XD**, US Naval Ordn Test Sta, China Lake (1952)
- 18) F. Pristera, "Infrared Method for Determination of Alpha, Beta, Gamma-Trinitrotoluene in Exudate Admixtures", *ApplSpectroscopy* **7**, 115-21 (1953)
- 19) H. Herman, "Determination of TNT, NH_4NO_3 and NaNO_3 Cratering Explosive by Non-Aqueous Titration", *PATR* **2384** (1958)
- 20) W.E. Fredericks & F. Pristera, *PATR* **2485** (1958)
- 21) A.R. Lusardi, "A Manual of Laboratory Procedures for the Analysis and Testing of Explosives and Pyrotechnics", Section 500, Expls & Proplnts Lab, PicArns, Dover (1959)
- 22) *Ibid*, Sections 800-900 (1959)
- 23) F. Pristera et al, *AnalChem* **32**, 495 (1960)
- 24) G.C. Whitnack, *AnalChem* **35**, 970 (1963)
- 25) S.K. Yasuda, "Identification of Impurities in Alpha-TNT by Thin-Layer Chromatography", *JChromatogr* **13**, 78-82 (1964)
- 26) S.A.H. Amao & H.J. Yallop, *Analyst (London)* **91**, 336 (1966)
- 27) *Encycl* **3**, C405-L to C417-R (1966)
- 28) J.D. Wilcox, "Differential Scanning Calorimetry Methods in the Determination of Thermal Properties of Explosives" (1967) (AD 818369/1st)
- 29) D.G. Gehring & J.E. Shirk, "Separation and Determination of Trinitrotoluene Isomers by Gas Chromatography", *AnalChem* **39**, 1315-18 (1967)
- 30) T.B. Beider, T.P. Bochkareva & E.S. Mikhaleva, *ZavodskayaLaboratoriya* **34**, 540 (1968)
- 31) J.C. Hoffsommer & J.F. McClullough, "Quantitative Analysis of Polynitroaromatic Compounds by Combination of Thin-Layer Chromatography and Visible Spectrometry", *JChromatogr* **38**, 508-14 (1968)
- 32) D.J. Glover & E.G. Kayser, "Quantitative Spectrophotometric Analysis of Polynitroaromatic Compounds by Reaction with Ethylene Diamine", *AnalChem* **40**, 2055 (1968)
- 33) D.G. Gehring & G.S. Reddy, "Nuclear Magnetic Resonance Examination and Determination of the Di- and Trinitrotoluenes", *AnalChem* **40**, 792-95 (1968)
- 34) A.B. Tronov & N.V. Pupova, *ZhKhimAbstr* **15G188** (1969)
- 35) A.E. Simchen, "Differential Thermal Analysis of Trinitrotoluene", *IsraelJTechnol* **7** (6), 445-48 (1945)
- 36) W. Commick, F.G.J. May & B.W. Thorpe, "Polymorphism in 2,4,6-TNT", *Defence Standards Labs, Australia* (1969) (AD 703112)
- 37) *Ibid*, "Ibid", *AustralianJChem* **22** (12), 2685-88 (1969)
- 38) G. Martel & M. Vignand, **LA-TR-6921**, Los Alamos Scientific Lab, New Mexico (1969)
- 39) F. Pristera & W.F. Fredericks, "Compilation of Infra-Red Spectra of Ingredients of Propellants and Explosives" (1969) (AD 859846)
- 40) D.M. Anderson, F.B. Kistner & M.J. Schwarz, "The Mass Spectra of Volatile Constituents in Military Explosives", 18 pp (1969) (AD 699325)
- 41) J.V. Maycock, *ThermochimActa* **1**, 389 (1970)
- 42) V.M. Aksenenko, A.P. Kreshkov & Z.V. Tatarnikova, "High-Frequency Titration of Aromatic Nitro Compounds as Acids in Anhydrous Solvents", *ZhAnalChim* **25** (10), 2028-32 (1970)
- 43) V.M. Aksenenko & Z.V. Tatarnikova, "Potentiometric Determination of Trinitrotoluene in Non-Aqueous Media in Presence of Nitric and Sulfuric Acids", *ProblAnalKhim* **1**, 118-24 (1970)
- 44) J.C. Hoffsommer, *JChromatogr* **51**, 243 (1970)
- 45) J.A. Kohlbeck, C.D. Chandler & W.T. Bolleter, "Application of Thin-Layer Chromatography for Improving the Continuous TNT Process", *JChromatogr* **56**, 173-79 (1970)
- 46) R. Jenkins & H.J. Yallop "The Identification of Explosives in Trace Quantities on Objects Near an Explosion", *Explosivst* **6**, 139 (1970)
- 47) J.C. Dacons, H.G. Adolf & M.J. Kamlet, "Some Novel Observations Concerning the Thermal Decomposition of 2,4,6-Trinitrotoluene", *JPhysChem* **74**, 3035-40 (1970)
- 48) V. Kucera, J. Havelka & B. Palma, "Determination of Tetranitromethane in Trinitrotoluene", *ChemPrum* **20** (12), 581-84 (1970)
- 49) D.G. Gehring, "Identification of Impurities in Alpha-Trinitrotoluene by Nuclear Magnetic Resonance", *AnalChem* **42** (8), 219-27; 498-504 & 898-902 (1970)
- 50) A.D. Coates, E. Freeman & L.P. Kuhn, "Characteristics of Certain Military Explosives", *BRL Rept* **1507**, Ballistics Res Lab, Aberdeen Proving Grnd (1970)
- 51) Anon, *Mil Spec*, "Trinitrotoluene (TNT)", **MIL-T-00248B** (1971)
- 52) Anon, *Engrg Des Hndbk*, "Explosives Series, Properties of Explosives of Military Interest", **AMCP 706-177** (1971)
- 53) F. Pristera, "Explosives", in "Encyclopedia of Industrial Chemical Analysis", Vol **12**, J. Wiley & Sons, NY (1971)
- 54) *Ibid*, "Titanous Reduction Method for Quantitative Determination of TNT", *Ibid* (1971), 421
- 55) A.G. Kelso, "The Importance of Sample Environment in the Gas Liquid Chromatographic Analysis of Trinitrotoluene",

- Tech Note 375, Australian Sci Service, Materials Research Labs, Dept of Defence (1971)
- 56) J.C. Hoffsmommer & D.J. Glover, *JChromatogr* **62**, 417 (1971) 57) J.C. Hoffsmommer & J.M. Rosen, "Ultramicro-Analysis of Explosives in Sea Water", *NOLTR 71-151*, Naval Ordn Lab, White Oak, Silver Spring, Md (1971) 58) P. Lingen, "Gas Chromatographic Determination of the Purity of Trinitrotoluene", *Explosivst* **19** (9 & 10), 162-64 & 166-70 (1971) 59) R.W. Dalton, J.A. Kohlbeck & W.T. Bolleter, "Gas Chromatographic Analysis of TNT from the Continuous Process", *JChromatogr* **50**, 219-27 (1970) 60) *Ibid*, Pittsburgh Conf, Cleveland, O (March 1970) 61) R.P. Murrman, T.F. Jenkins & D.C. Leggett, "Composition and Mass Spectra of Impurities in Military Grade TNT Vapor" (1971) (AD-725474) 62) T.L. Chang, "Identification of Impurities in Crude TNT by Tandem GC/MS Technique", *AnalChimActa* **53** (2), 445-48 (1971) 63) D.B. Parihar et al, *MicrochimicaActa* (Vienna), 393-98 (1971) 64) D.E. Chasan & G. Norwitz, "Quantitative Analysis of Primers, Tracers, Incendiaries, Boosters and Delays on a Micro Scale by Use of Infrared Spectroscopy" (1971) (AD 729337) 65) R.P. Murrman, T.F. Jenkins & D.C. Leggett, "Composition and Mass Spectra of Impurities in Military Grade TNT Vapor", *SR158*, Cold Regions R&E Lab, Hanover, NH (1971) 66) C.R. Newhauser & P.M. Dougherty, "Explosives Handling Detection Kit", *Tech Bull* **33-73**, US Dept of Justice, Gaithersburg, Md (1972) 67) J.C. Hoffsmommer & J.M. Rosen, *BullEnvironContamToxicol* **7** (2/3), 177-81 (1972) 68) C.D. Chandler, J.A. Kohlbeck & W.T. Bolleter, "Continuous TNT Process Studies. III. Thin-Layer Chromatographic Analysis of Oxidation Products from Nitration", *JChromatogr* **64**, 123-28 (1972) 69) *Ibid*, "IV. Identification and Determination of Purification Products", *JChromatogr* **67**, 255-59 (1972) 70) F. Volk & H. Schubert, *Explosivst* **16**, 2 (1972) 71) J. Yinon, H.G. Boettger & W.P. Weber, "Negative Ion Mass Spectrometry. New Analytical Method for Detection of Trinitrotoluene", *AnalChem* **44** (13), 2236-37 (1972) 72) J. Yinon & H.G. Boettger, "Modification of a High-Resolution Mass Spectrometer for Negative Ionization", *IntJMassSpectromIonPhys* **10** (2) (1972) 73) M. Aubar & J.T. Moseley, *USP Applic* 288960 (14 Sept 1972) 74) W. Selig, "Some Analytical Methods for Explosives and Explosive Simulants", *UCRL-7873* (Pt 4) (1973) 75) J.S. Hetman & F. Fresenius, "Polarography of Explosives", *AnalChem* **264** (2), 159-64 (1973) 76) L.W. Hrubesh et al, "Study of Conventional Preconcentration Techniques for Explosive Vapors" (1973) (AD A026117) 77) T. Krasiejko & I. Missala, "Analysis of Toluene Nitration Products by Gas Chromatography", *ChemAnal* **18** (5), 1081-83 (1973) 78) T.F. Jenkins et al, "Analysis of Vapors Emitted from Military Mines" (1973) (AD 768709) 79) W.F. O'Reilly et al, "Exploratory Analysis of Vapor Impurities from TNT, RDX and Comp B" (1973) (AD 769731) 80) J.W. Harrison, "Comparative Evaluation of Trace Gas Technology; Analysis and Evaluation of Instrumental Methods" (1973) (AD 777968) 81) J.T. Walsh et al, "Application of Liquid Chromatography to Pollution Abatement Studies of Munition Waste", *AnalChem* **45** (7), 1215-20 (1973) 82) L.A. Spano et al, "Abatement of Nitrocompounds in Aqueous Effluents from TNT Production and Finishing Plants", *Pollnt Eng Sci Solutions, Proc Int Meet, Soc, Eng Soc*, 288-97 (1973) 83) A.A. Juhasz & J.O. Doali, "High Performance Liquid Chromatographic Separations of Thermally Labile High Energy Compounds. Part II. Infrared Spectral Characterization of Micro-Preparative HPLC Fractions (1973) (AD 769713) 84) T.F. Jenkins, R.P. Murrman & D.C. Leggett, "Mass Spectra of Isomers of Trinitrotoluene", *JChemEng* **18** (4), 438-39 (1973) 85) W.A. Wall & M.G. Herbert, "Detection of TNT Vapors" (1973) (AD 785693) 86) J.W. Harrison, "Comparative Evaluation of Trace Gas Technology. Vol II: Analysis and Evaluation of Instrumental Methods" (1973) (AD 777868) 87) J.L. Menke, "Spot Tests for Explosives/Incendiary Components and Residues", *General Information Bull* **74-8**, Natl Bomb Data Center, US Dept of Justice, Washington, DC (1974) 88) C.M. Hoffman & E.B. Byall, "Identification of Explosive Residues in Bomb Scene Investigations", *JForensicSci* **19** (1), 54-63 (1974) 89) F. Cuta & E. Beranek, "Spectrophotometric and Chromatographic Investigation of the Reaction of 2,4,6-Trinitrotoluene with Sodium Hydroxide", *CollectCzechChemCommun* **39** (3), 736-

- 41 (1974) 90) R.F. Walker & T.C. Castorina, "Chemical Characterization of Energetic Materials, their Decomposition Products and their Residues—Progress in the Identification and Detection of Explosives", *PATM* **2136** (1974)
- 91) J.O. Doali & A.A. Juhasz, "Application of High-Performance Liquid Chromatography to the Qualitative Analysis of Compounds of Propellant and Explosives Interest", *JChromatogrSci* **12** (1), 51–56 (1974) 92) F.T. Sweeney & P.W.D. Mitchell, "Aerosol Explosive Indicator Kit" (1974) (AD 784196/8) 93) L.J. Schiff, D.H. Rosenblatt & W.H. Dennis, Jr (1974) (AD 775811/3) 94) I.R.C. Duke, "The Crystallography of TNT and HNS", *WAC 1/033WAA 264/40*, Expls R&D Establishment, Waltham Abbey, Engl (1974) 95) G.E. Spangler, "Membrane Technology in Trace Gas Detection", Rept **2089**, US Army Mobility Equip R&D Center, Ft Belvoir, Va (1974) 96) F.W. Karasek & D.W. Denney, *JChromatogr* **93**, 141 (1974) & *Research/Development* 32–36 (May 1974) 97) R.G. Gillis, M.J. Lacey & J.S. Shannon, "Chemical Ionization of Explosives", *OrgMassSpectrum* **9** (3), 359–64 (1974) 98) R.G. Parker et al, "Analysis of Explosives and Explosive Residues, Part I: Chemical Tests", *JForensicSci* **50**, 133–40 (1975) 99) omit 100) J. Flack, "Polarographic Determination of Trinitrotoluene in the Presence of Dinitrotoluene", *HungSciInstrum* **32**, 11–12 (1975) 101) G.C. Whitnack, *AnalChem* **47**, 618 (1975) 102) A. Brandone et al, 7th Int Mtg Forensic Sci, Zurich (1975) 103) M. Anbar & J.T. Moseley, "Detecting Explosives", *USP 3929987* (1975) 104) A. Jenkins, "Qualitative and Quantitative Detection of Vapors from Low Volatility Compounds", *USP 3883739* (1975) 105) L. Elias & M. Krzymien, "Methods of Evaluating the Sensitivity of Explosives Vapor Detectors", *Lab Tech Rept LTR-VA*, Natl Res Council, Canada (1975) 106) T. Kraziejko, "Use of Gas Chromatography for Analysis of Toluene Nitration Products", *PrInstPrzemOrg* **6**, 59–63 (1975) 107) N.B. Jurinski et al, "Comparison of Analytical Methods for Trace Quantities of 2,4,6-Trinitrotoluene", *JAmInd-HygAssoc* **36** (7), 497–502 (1975) 108) C. Merritt, Jr, "Applications of Pyrolysis GC/MS in the Analysis of Organic Nitro Compounds", *Proc 23rd Annual Conf on MS & Allied Topics*, Houston, Texas (May 1975), 42 109) R.G. Parker et al, "Analysis of Explosives and Explosive Residues", *JForensicSci* **20** (2), 254–56 (1975) 110) A.W. Archer, "Separation and Identification of Minor Components in Smokeless Powders by Thin-Layer Chromatography", *JChromatogr* **108** (2), 401–04 (1975) 111) W.L. Rollwitz & J.D. King, "Adsorption Detection of Explosives Hidden in Airline Baggage" (1975) (AD A022111/9ST) 112) D.H. Freeman, "The Study of Chemical Interactions as Applied to Forensic Sciences" (1975) (AD A005078/IGA) 113) G.E. Spangler, "Membrane Technology in Trace Detection Evaluation of the Universal Monitor Olfax Instrument" (1973) (AD 777519/OGA) & *AmLab* **36** (8), 40–45 (1975) 114) H. Kramer, S. Semel & J.E. Abel, "Trace Elemental Survey Analysis of TNT", *PATR 4257* (1975) 115) R. Michnowicy, J.M. Chao & J.J. Manura, *JAssoc of AnalChem* **58**, 734 (1975) 116) G.E. Spangler, "Detection of Nitroaromatics with Plasma Chromatography/Preconcentration", *EO-SP-76001*, Proc 6th Ann Symp Trace Anal Detect Environ, 141–48 (1975) 117) R. Saferstein, J.M. Chao & J.J. Manura, "Isobutane Chemical Ionization Mass Spectrographic Examination of Explosives", *JAssoc of AnalChem* **58**, 734–42 (1975) 118) G.A. St John et al, "Determination of the Concentration of Explosives in Air by Isotope Dilution", *JForensicSci* **6**, 53–66 (1975) 118a) W.J. Fisco, A.F. Smetana & T.C. Castorina, "Extended Application and Modification of a Portable Explosive Identification Kit for Field Use", *PATR 4796* (1975) 119) W.C. McCrone, "Applications of Hot-Stage Microscopy", 1st Proc European Therm Anal, 63–66 (1976) 120) G.C. Whitnack, "Determination and Monitoring of Some Organic Explosives in Natural and Effluent Water by Single-Sweep Polarography", *IdentifAndOrgPollutWater*, 265–79 (1976) 121) P.A. Pella, "Generator for Producing Trace Vapor Concentrations of TNT, 2,4-DNT and EGDN for Calibrating Explosive Vapor Detectors", *AnalChem* **48**, 1632–37 (1976) 122) J. Haberman & C. Ribando, "The Gas Chromatographic Detection and Estimation of Trace Isomer Impurities in Military Grade TNT", *PATR 4963* (1976) 123) M. Halik & C. McIntosh, "New Control Instrumentation for

- Manufacture of Energetic Materials" (1976) (AD A038284/6ST) 124) T.N. Hall & G.W. Lawrence, "A Study of the Organic Components of Red Water" (1976) (AD A034226) 125) J.E. Chrostowski et al, *JForensicSci* **21**, 611 (1976) 126) M.D. Kemp, "Survey of Bioluminescence Pertinent to Explosives Detection" (1976) (AD A047257/3ST) 127) T.L. Hess et al, "Automated System for Analysis of Nitro Compounds in Water", *BullEnvironContam-Toxicol* **13** (5), 579-81 (1975) 128) R.J. Piffath & S. Sass, "Application of Infrared and Raman Spectroscopy to the Analysis of Phosphoric Acids and their Salts (GB-Related Compounds)" (1976) (AD A026736) 129) C.R. Midkiff & W.D. Washington, "Systematic Approach to the Detection of Explosive Residues", *JAssoc of AnalChem* **59** (6), 1357-74 (1976) 130) S. Zitrin & J. Yinon, 7th Int Mass Spectrometry Conf, Florence, Italy (Sept 1976) 131) Ibid, "Chemical Ionization Mass Spectrometry of Explosives", *Adv in Mass Spec in Bio Chem and Med* **1**, 369 (1976) 132) R.E. Wyant, "Development of a Simple Portable Detection Kit for Selected Explosives" (1977) (AD A045000) 133) D.C. Leggett, "Determination of 2,4,6-Trinitrotoluene Water by Conversion to Nitrate", *AnalChem* **49** (6), 880 (1977) 134) P.L. Legus et al, *PropInts&Expls* **2** (4), 81-84 (1977) 135) E. Steeman, "Pulse Polarographic Determination of Trinitrolycerin in Explosives", *BullSocChemBelg* **86** (1-2), 17-21 (1977) 136) J. Yinon, "Analysis of Explosives", *CRC Critical Reviews in Analytical Chemistry* (Dec 1977) 137) D.C. Leggett et al, "Composition of Vapors Evolved from Military TNT as Influenced by Temperature, Solid Composition, Age and Source" (1977) (AD A040636) 138) D.C. Leggett, "Vapor Pressure of 2,4,6-Trinitrotoluene by a Gas Chromatographic Headspace Technique", *JChromatogr* **133** (1), 83-90 (1977) 139) P.A. Pella, "Measurement of the Vapor Pressures of TNT, 2,4-DNT, 2,6-DNT and EGDN", *JChemThermodynamics* **9**, 301-05 (1977) 140) D.J. Glover et al, "Analysis of Mixtures of Amino Nitrotoluenes", *AnalChem-Acta* **88** (2), 381-84 (1977) 141) J. Nakamura, "Gas Chromatographic Detection and Determination of the Base Charge in a Blasting Cap", *Kagabu Keisatsu Kensyuko Hohoku* **30**, 259-63 (1977) 142) L.K. Isaeva, Y.N. Bogoslovsku & N.V. Kolycheva, "Teoriva i Praktika Gasokhromatogr Analiza", 52-53 (1977) 143) M.A. Kaplan & S. Zitrin, "Identification of Post-Explosion Residues", *AnalChem* **60** (2), 619-24 (1977) 144) P. Vouros et al, "Analysis of Explosives by High Performance Liquid Chromatography and Chemical Ionization Mass Spectrometry", *Anal* **49** (7), 1039-44 (1977) 145) P. Barth, "Quantitative Spectrophotometric Analysis of Polynitroaromatics", *Analysen-Methoden Treib-Explosivst*, 283-97 (1977) 146) T.C. Castorina, J. Haberman & J. Sharma, "Charcoal Regeneration. Part I. Mechanism of TNT Adsorption", **ARLCD-TR-77065**, US Army ARRADCOM, Dover (1977) 147) C.A. Heller et al, "Detection of Trinitrotoluene in Water by Fluorescent Ion-Exchange Resins", *AnalChem* **49** (14), 2251-53 (1977) 148) R.A. Marino, D. Wade & S.M. Klainer, "An NQR Study of the TNT Characteristics" (1977) (AD A046729) 149) D.V. Canfield et al, "Use of the Gandolfi Camera as a Screening and Confirmation Tool in the Analysis of Explosive Residues", *JForensicSci* **22** (2), 337-47 (1977) 150) N.M. Reid, J.A. Buckley & J.B. French, "The Real Time Detection of Trinitrotoluene in Ambient Air Using TAGA System", *UTIAS Tech*, 213, 7 (1977) 151) P.A. Lawless, "Trace Gas Field Instrumentation Van and Explosive Detection Research" (1977) (AD A043251/8ST) 152) H.R. Schulton & W.D. Lehman, "High-Resolution Field Desorption Mass Spectroscopy. Part VII. Explosives and Explosive Mixtures", *AnalChem-Acta* **93**, 19-31 (1977) 153) A. Alm et al, "Analyses of Explosives", **FAO Rept C-20267-D1**, Forsvarets Forskningsanstalt, Stockholm (1978) 154) W.J. Fisco, J. Haberman & T.C. Castorina, "The Behavior of Some Waxes in Composition B", **ARLCD-TR-78067**, US Army ARRADCOM, Dover (1978) 155) K. Donovan et al, "Detection of Explosive Vapors by Enzymatic Methods" (1978) (AD A051582/5ST:PC) 156) J. Epstein et al, "Environmental Quality Standards Research on Wastewaters of Army Ammunition Plants" (1978) (AD A056318/9ST:PC) 157) T.H. Chen & M. Gilford, "Analysis of Impurities in Composition B by Thin-Layer Chromatography" (1978) (AD A056313/0ST) 158) E.P. Meir, L.C.

Taft & A.P. Graffes, "The Determination of Selected Munitions and their Degradation Products Using High Performance Liquid Chromatography", *Joint Conf Sens Environ Pollut* (1978) 159) M. Roth, "Continuous Monitoring of Pink Water from Carbon Adsorption" (1978) (AD 242/1ST:PCA03/MFA01) 160) K. Garoutte, "Analytical Method for Determining Trinitrotoluene in Water", *USP Applic* 770718 (1978) 161) omit 162) R.J. Kopec et al, "Forensic Applications of Sapphire Cell-Infrared Spectroscopy: Companion to the Diamond Cell in Explosive and Leg Wire Identification", *JForensic Sci*, 57-65 (1978) 163) S. Bulusu, "Mass Spectrometry" in this Encycl, Vol 8, M19-L to M39-R (1978) 164) G.E. Spangler & P.A. Lawless, "Ionization of Nitrotoluene Compounds in Negative Ion Plasma Chromatography", *AnalChem* 50 (7), 884-92 (1978) 165) S. Zitron & J. Yinon, "Mass Spectrometric Studies of Trinitroaromatic Compounds", *AdvMass-Spectrom* 7B, 1457-64 (1978) 166) C.T. Pate & M.H. Mach, "Analysis of Explosives Using Chemical Ionization Mass Spectroscopy", *IntJ-MassSpectromIonPhys* 26 (3), 267-77 (1978)

TNTAB. Trinitrotriazidobenzene (USA). See Vol 2, B43-R

TNTCIB. Trinitrochlorobenzene (USA)

TNTF (2,4,6-Trinitrobenzotrifluoride).

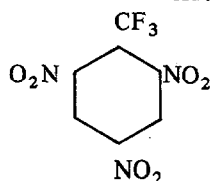

$C_7H_2N_3F_3O_6$; mw 281.11; N 14.95%; OB to CO_2 -51.23%; white ndls; mp 87° , $88.6-91.2^\circ$, $88.3-91.0^\circ$, $89.5-90^\circ$ (separate values). Sol in hot trichlorethylene. Prepn is by reacting a soln of Na iodide in acet/glacial acetic acid with a soln of 3-chloro-2,4,6-trinitrobenzotrifluoride in acet at RT with stirring for 24 hrs. The reaction mixt is then drowned in an aq soln of Na sulfite. This procedure serves to separate an oily product-containing layer which is then extracted with hot

trichlorethylene. Upon cooling the product solvent mixt, the crude TNTF solidifies and is filtered off. Purification of the crude TNTF is then accomplished by liq chromatography using neutral alumina for the column and benz as the carrier solvent

TNTF has a booster sensy of 0.170g of Tetryl (TNT, 0.270g of Tetryl); brisance by sand test of 43.4g crushed (100.9% of TNT); deton rate of 6919.6m/sec at d 1.718g/cc, 6770.2 m/sec at d 1.686g/cc and 6819.0m/sec at d 1.735g/cc; 5 sec expln temp of 418° (closed cup) and 450° (open cup); friction pendulum result of no expln using a steel shoe; Q_c of -2423.9cal/g (Parr bomb) and -2504.2cal/g (rotating bomb); Q_e of 799.9cal/g ; Q_f of -524.05cal/g ;

Time, hrs	Heat Test at 100°		
	1st 48	2nd 48	100
% wt loss	0.75	0.48	No expln;

hygroscopicity of 0.00% at 30° and 90% RH; an impact sensy of 56+ inches (Bruceton Machine, 5-kg wt, Ref 2), 10% pt of 13 inches (PicArns app, 2-kg wt), and 50% pt of 17.0 ± 1.10 inches (Bruceton data procedure, 2-kg wt, PicArns app); power by BalMort of 100.8% TNT and by Trauzl Test of 114.3% TNT; a primer sensy of 0.200g of LA (0.240g required for TNT), 0.334g TNTF pressed at 4000psi required 0.334g of LA (TNT required $>0.334\text{g}$ LA) (separate values); sensy to initiation by static electricity of "no ign" when exposed to a 23000 volt discharge from a 2000 picofarad capacitor (0.53J);

Vac Stab Test	
Temp $^\circ$ /time	cc gas evolved/g/hr
100/40 hrs	0.20
120/40 hrs	0.21
200/2 hrs	0.17
290/2 hrs	4.83

Refs: 1) Beil, not found 2) D.N. Thatcher & G.A. Noddin, "Bulk Synthesis of Fluorochemicals", Tech Rept **ATL-TDR-64-19**, duPont, Gibbstown, Contract AF 08 (635) 2965 (1964), pp 10, 11 & 21 3) H.J. Jackson et al, "A Comparative Evaluation of Selected Fluoroexplosives", *PATR* 3941 (1970), pp 2 & 21-34

TNTMNA. Trinitrotolylmethylnitramine (USA)

TNX. Trinitroxylene; Trinitromethylbenzene (USA). See in Vol 5, D1324-R to D1325-L

TOFLOX. Soln of ozonefluoride in liq oxygen. See under "Liquid Propellants" in Vol 7, L34-R ff
Ref: R. Meyer, "Explosives", Verlag Chemie, NY (1977), 355

Tol or Trotil (Rus). Trinitrotoluene, TNT. See "Trotil ili Tol" under "Russian Explosives and Related Items" in this Vol

Tolamex. Brit permissible expl which passed the Buxton test: AN 35, K nitrate 34, TNT 14, amm chloride 17%; BalPend swing 2.45"
Ref: Marshall 3 (1932), 119

Tolamite. Fr coal mining expl, nonpermissible. See Vol 3, C438-R for formulation. Meyer (Ref 2) states it is the trade name of a gelatinous industrial expl distributed in Fr by Nobel-Bozel and the Société Anonyme Des Explosifs. Its d is 1.50g/cc; wt strength (calcd from c.u.p. value of 131) is 85%
Refs: 1) L. Médard, MP 32, 217 (1950)
 2) R. Meyer, "Explosives", Verlag Chemie, NY (1977), 295

Tolite or Trotyl (Fr). Trinitrotoluene, TNT. See under "French Military Explosives, Requirements" in Vol 6, F195-R

Tolite/D is TNT of high purity, solidification point (s p) above 80.6°. It was prepd by washing *Tolite /T* (see below) with 2–3% of cold Na sulfite soln, as described in MP 24, 263 (1930–1931) and Pepin-Lehalleur (1935), 177

Tolite/M is crude TNT, sp 78–79°, prepd as described in MP 24, 262 (1930–1931)

Tolite/O is crude TNT, sp 79–80.1°, prepd as described in MP 24, 262 (1930–1931) and Pepin-Lehalleur (1935), 177

Tolite/T is TNT, sp 80.1–80.6°, obtained by purification of crude TNT with sulfuric acid, as described in MP 32, 262 (1930–1931)

Toluene and Derivatives

Toluene (Methylbenzene, Methacide, Phenylmethane or Toluol). $C_6H_5CH_3$, C_7H_8 ; mw 92.13; flammable (flash pt $40^\circ F$), refractive liq, benz-like odor; fr pt -94.5° , -95° (sep values); bp 110.6° ; d 0.866g/cc at $20/4^\circ$; RI 1.4967. V sl sol in w; miscible with acet, ethanol, chl f, eth, glacial acetic acid and C disulfide. CA Registry No [108-88-3]

History. Pelletier and Walter (according to Ref 4) first discovered toluene while evaluating the degradation products obt'd from heating a natural resin, the balsam of Tolu, named for a small town in Colombia, South America. This balm was used as a medicine and in perfumery, and even today is so employed in small amounts. In

the latter part of the nineteenth century toluene was produced from the by-product chemicals recovered from coal carbonization. The prodn of toluene from petroleum was developed a number of years after this. Toluene can be obt'd from several petroleum or petrochemical processes such as catalytic cracking, hydrocracking, reforming and steam cracking. Today, the principal methods of manuf are by: a) catalytic reforming of petroleum and b) fractional distn of coal-tar light oil (Refs 4 & 5a)

Toluene rose to prominence during WWI as the basis for 2,4,6-Trinitrotoluene (TNT) manuf. The demand became so great that petroleum sources were used to augment coal-tar sources. The petroleum process involved narrow cut naphthas contg small amts of toluene which were subjected to thermal cracking to produce a

Table 1
Effects of Toluene Vapor (Ref 4)

Concentration, ppm	Time of Exposure, hrs	Probable Response	Probable Aftereffects
50-100	8	No serious effects; slight drowsiness and possibly slight headache in the unconditioned workers	None
200	8	Unconditioned workers may complain of fatigue, some muscular weakness, and burning, itching or "crawling" skin; there may be complaints of headache and some nausea	Unconditioned workers may complain of fatigue of short duration and a few may suffer restless sleep
300-400	8	Varying degrees of fatigue and headache; varying degrees of muscular weakness, mental confusion and slight incoordination	Fatigue lasting several hours and insomnia
600	3	Marked fatigue and mental confusion, exhilaration, headache, and dizziness	Fatigue and weakness lasts several hours
	8	Definite mental confusion, considerable incoordination and staggering gait	There may be complaints of nausea and nervousness; many suffer headache
800	3	Nausea and pronounced confusion; considerable incoordination and staggering gait	Nervousness and fatigue may last several days; there may be marked insomnia

toluene concentrate. The purified concentrate was then used as a precursor for TNT. The petroleum prodn process was discontinued for economic reasons after WWI

The need for toluene was so pronounced during WWII that a commercial process for converting petroleum naphthenes to aromatics, which was used to make high quality gasolines, was put into max prodn of "Toluene hydroformate" for eventual TNT prodn. The purification of the hydroformate was accomplished by use of an improved Edeleanu extrn process which included the added feature of a heavy paraffin wash oil as a second solvent. The reforming-extrn processing of selected naphthas from crude oil has resulted in the development of a huge petroleum aromatics industry. Today, this process not only produces toluene, but essentially all of the commercial requirements of C₆ to C₈ aromatics as well. Toluene is generally produced by reforming in admixt with C₆-C₈ aromatics, precursors to give a so-called BTX (benzene-toluene-xylene) fraction. This is purified by extrn and distn to give pure toluene as well as benzene and xylene (Ref 4)

Toluene has an autoign temp of 947°F, 997°F (sep values) and flammable vapor level limits of 1.27 to 7.0%, 1.4 to 6.7% (sep values)

The Natl Fire Protection Assoc (Ref 10) reports the following *expl reactions* of toluene: with *nitric-sulfuric acids* (if nitration conditions are not properly controlled) (p 272 of 491M) and with *nitrogen tetroxide* (p 278 of 491M). Also reported is the *shock-sensitive solvated salt* formed with *silver perchlorate-acetic acid* (pp 367-68 of 491M)

The US Mil Federal Specification for technical grade toluene is **TT-T-548D**, dated Jan 12, 1970 (Ref 5)

The toxic threshold limit value as reported by Sax (Ref 3) is 200ppm in air or 750mg/m³ of air, and by Plunkett (Ref 8) is 100ppm and 375mg/m³. Acute poisoning from the use of toluene is the result of a small amount of benz in commercial (coal-tar) derived toluene. Table 1 presents the effects of toluene vapor (Ref 4). Plunkett (Ref 8) reports that prolonged exposure to toluene vapor can result in permanent central nervous system changes such as cerebellar degeneration, tremulousness, ataxia, emotional lability and EEG changes

The major uses of toluene are in high-octane (Pb-free) motor fuels, paints, dyes, plastics, detergents and expls. The usual route to useful expls is by the nitration of toluene to mono-, di-, and trinitro derivatives. See also in Vol 8, N40-R ff under "Nitration", and N211-L & R under "Nuclear Tracers in Explosive Chemistry"

The expl derivatives of toluene are described next

Refs: 1) Beil 5, 280, (144), [209, 762] & {651}; 7, [940]; & 14, [653] 2) Urbański 1 (1964), 67 ff 3) Sax (1968), 1168-69 4) Kirk & Othmer, Vol 20, 2nd Edn (1969), 527-65 5) Anon, "Toluene, Technical", Fed Spec **TT-T-548D** (Jan 12, 1970) 5a) J.A. Kent, Ed, "Riegel's Handbook of Industrial Chemistry", Seventh Edn, VanNostrand Reinhold, NY (1974), 431 6) Anon, "Fire Protection Guide on Hazardous Materials", Sixth Edn, NFPA, Boston (1975), 49-284 6a) N. Sugiyama et al, "Liquid Explosives Containing Nitroglycerin and/or Nitroglycol, and Insensitive to Impact and Detonation During Storage or Transport", JapP 74-36811 (1974) & CA 83, 63049 (1975) 7) Merck (1976), 1225 (No 9225) 8) E.R. Plunkett, "Handbook of Industrial Toxicology", Chemical Publishing Co, NY (1976), 412-14 9) Cond-ChemDict (1977), 868 10) Anon, "Fire Protection Guide on Hazardous Materials", Seventh Edn, NFPA, Boston (1979), pp 491M-272, 278, 367-68 & 422

Toluene Azides

2-Azido-Toluene (or o-Tolylazide).

N₃.C₆H₄.CH₃, C₇H₇N₃; mw 133.17; N 31.56%; OB to CO₂ -210.26%; lt yel oil; fr p, does not solidify at -10°; bp 90.5° at 31mm; d 1.0709 g/cc at 22.2/4°. Sol in eth. CA Registry No [31656-92-5]. Prepn is by reacting o-toluene-diazonium chloride with K-benzene sulfamide in KOH. The compd expls when heated at atm press

Ref: Beil 5, [273]

ω-Azido Toluene. See in Vol 2, B94-R under "Benzylazide and Derivatives"

ω-Azido-2-Methoxy Toluene (1'-Azido-2-

methoxytoluene or 2-Methoxybenzylazide). $\text{CH}_3\text{O.C}_6\text{H}_4.\text{CH}_2\text{N}_3$, $\text{C}_8\text{H}_9\text{N}_3\text{O}$; mw 163.20; N 25.75%; OB to CO_2 -191.18° ; oil; bp 118° at 14mm; d 1.063g/cc at $20/4^\circ$; RI 1.5272. Prepn is by reacting N-nitroso-N-(2-methoxybenzyl)-hydrazine with dil sulfuric acid. The compd explds on rapid heating
Refs: 1) Beil 6, (181) 2) F. Moulin, *Helv-ChimActa* 35, 167-80 (1952) & CA 46, 8651 (1952)

p-Toluenesulphonyl Azide. $\text{CH}_3.\text{C}_6\text{H}_4(\text{SO}_2)\text{-N}_3$, $\text{C}_7\text{H}_7\text{N}_3\text{O}_2\text{S}$; mw 197.23; N 21.31%; OB to CO_2 -109.52° ; mp 22° . Prepn is by reacting p-toluenesulphonyl chloride with Na azide in 90% ethanol. The yield is 83%. The azide explds when heated over 120° . It resembles Tetryl in expl character
Refs: 1) Beil 11, [67] 2) T. Curtius & G. Kramer, *JPraktChem* 125, 343 (1930) & CA 24, 3229 (1930) 2a) G.P. Balabanov et al, *Zh-PriklKhim* 1968, 41 (11), 2578-80 & CA 70, 59427 (1969) 3) D. Rewicki et al, *AngChem (InternlEdn)* 11, 44 (1972) & CA 76, 99191 (1972)

The Azotoluenes and Nitro Derivatives. See in Vol 1, A660-L to A662-L

The Toluene Diazonium Salts. See in Vol 5, D1177-R to D1179-L under "Diazotoluene and Derivatives", and D1193-L & R under "3,5-Dibromo-4-Diazotoluene" and the following *Addnl Compds:*

The Toluene Diazonium Iodides. These compds are expl in the cryst state:

Ortho- and meta-Toluenediazonium iodide. $\text{CH}_3.\text{C}_6\text{H}_4.\text{N}_2.\text{I}$, $\text{C}_7\text{H}_7\text{N}_2\text{I}$; mw 246.06; N 11.39%; red-brn cryst; mp, decompn below 0° (stable at -180°). Isolated as by-products in the diazotization of (o- and m-) aminotoluene upon the addn of a Na iodide soln to the diazotized material

o-Toluenediazonium Triiodide. $\text{CH}_3.\text{C}_6\text{H}_4.\text{N}_2.\text{I}_3$, $\text{C}_7\text{H}_7\text{N}_2\text{I}_3$; mw 499.86; N 5.61%; orange-yel cryst, darkens rapidly in air; mp, decompn at 50° . Sol in and decompd by w and polar solvents; not sol in non-polar solvents. Prepn is by reaction of o-toluenediazonium sulfate, dissolved in aq sulfuric acid, with aq K iodide at $0-5^\circ$. The triiodide is *v expl*

p-Toluenediazonium Triiodide. $\text{CH}_3.\text{C}_6\text{H}_4.\text{N}_2.\text{I}_3$, $\text{C}_7\text{H}_7\text{N}_2\text{I}_3$; mw 499.86; N 5.61%; mp, decompn at 30° . Also a by-product in the diazotization of p-aminotoluene, on the addn of aq K iodide soln to the diazotized material
Refs: 1) Beil, not found 2) J.G. Carey, *Chem&Ind(London)*, 97 (1960) & CA, not found

Diazotoluenesulfonic Acid and Derivatives. See in Vol 5, D1179-L to D1180-L

Diazotoluenesulfonic Acid, Halogenated Derivatives. See in Vol 5, D1180-L

Toluenediisocyanate, Aminoethylation of. See in Vol 1, A203-R under "Aminoethylation of Toluene Diisocyanate (AETDI)"

Toluene 2,4-Diisocyanate (Tolylene diisocyanate, 2,4-Diisocyanatotoluene, TDI, Nacconate 100, or Metatolylene diisocyanate).

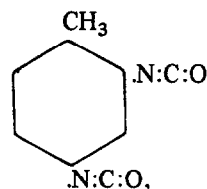

$\text{CH}_3.\text{C}_6\text{H}_3(\text{NCO})_2$, $\text{C}_9\text{H}_6\text{N}_2\text{O}_2$; mw 174.15; N 16.09%; OB to CO_2 -174.56° ; w-white to pale yel liq, darkens on exposure to sunlight, sharp pungent odor, mp $19.5-21.5^\circ$; bp 251° ; d 1.2244g/cc at $20/4^\circ$. Miscible with ethanol (decompn); sol in acet, benz, diglycol mono-methyl ether, eth, C tetrachloride and other org solvents. Reacts with w evolving CO_2 . Concd alkalies, bases such as tertiary amines or traces of acyl chlorides may cause runaway (violent) polymerization. CA Registry No [584-84-9]. Prepn is by reaction of toluene-2,4-diamine and phosgene in o-dichlorobenzene

TDI has a flash pt of 132° (open cup) and flammable vapor level limits of 0.9 to 9.5%

2,4-Tolylene diisocyanate is used as a constituent (cross-linking agent) of polyurethane expls, propnt binders, and as a component of a ballistic modifier (*Refs* 2a, 8 & 9). See in Vol 8, P68-Table 3 under "PBX Type Explosives-Composition" (listed as "Polyurethane" in the "Binder, %" column), and P409-R to P415-Table 17 under "B. Composite Propellants"

According to Sax (Ref 2) TDI is capable of producing severe dermatitis and bronchial spasms. It is especially irritating to the eyes. The threshold limit is 0.02ppm in air or 0.14 mg/m³ of air. Also see Plunkett (Ref 6, pp 222-24)

The US Mil Specification for toluene diisocyanate is MIL-T-23624(1), dated April 2, 1974 (Ref 3a)

Refs: 1) Beil 13, 138 2) Sax (1968), 1171 2a) L. Hunter & E.E. Ryder, Jr, "Energetic Binder Production", AFRPL-TR-68-184, Shell Dev Co, Emeryville, Contract AF04(611)-11645 (1968) 3) Kirk & Othmer, Vol 12 (1969), 55-63 ("Isocyanates, Organic") 3a) Anon, "Tolylene-2,4-Diisocyanate", MIL-T-23624(1) (02 April 1974) 4) Bretherick (1975), 566 5) Merck (1976), 1225-26 (No 9226) 6) E.R. Plunkett, "Handbook of Industrial Toxicology", Chemical Publishing Co, NY (1976), 222-24 7) CondChemDict (1977), 868-69 8) T.E. Dunigan et al, "Ballistic Modifier Resistant to Hydrolysis", USP 3994946 (1976) & CA 86, 75487 (1977) 9) Ibid, USP 3994757 (1976) & CA 86, 75488 (1977)

The Mononitrotoluenes (Methylnitrobenzene, MNT, Nitrotoluene, Nitrotoluol, or Nitrotoluéne). The two compds of interest are the ortho- and para-isomers. They are used primarily as precursors or intermediates in the manuf of TNT (qv), as they yield pure 2,4,6-TNT on nitration (Ref 9). Another industrial use is in the manuf of 2,4-Dinitrotoluene (Ref 2)

(O₂N).C₆H₄.CH₃, C₇H₇NO₂; mw 137.14; N 10.22%; OB to CO₂ -180.9%. Selected properties of each isomer are presented in Table 2

Prepn of all three of the isomers of nitro-toluene is usually by nitration of toluene with varying concns of mixed acid. However, Urbański (Ref 2, p 274) reports that a soln of nitric acid in acetic anhydride (32/68%) at 10° results in a mixt of 88% ortho- and 12% para-mononitrotoluenes. Olah (Ref 4), in evaluating over 100 systems for the mononitration of toluene, indicates (as one of the better procedures) that the use of mixed acid in toluene itself as the solvent at -15° results in obtaining 47.5 ortho-, 1.1 meta-, and 5.14% para-MNT. Urbański further reports on an industrial procedure used at Griesham by I.G. Farbenindustrie (Ref 2, p 276) where nitric acid (28-32), sulfuric acid (52-56) and w (20-12%) are used to nitrate 3000ℓ of toluene at 25° for 8 hrs. The resulting product mixt contains 62-63 ortho- and 33-34% para-isomers. Separation of the isomers is accomplished by either of two methods: (1) By vacuum fractional distln; (2) By freezing. At -12°, the para isomer crystallizes out, leaving the ortho and meta in the liq state. Further cooling results in the crystn of the ortho isomer, while the meta isomer remains liq (forming a eutectic with the ortho isomer). Again, according to Urbański (p 277), to obtain 100kgs of mixed isomers by the above procedure requires toluene (69), mixed acid (150), 10% NaOH soln (22kg), 22kW hours of electricity, and 930 kgs of steam

Table 3 shows selected thermochemical and energetic properties of both ortho- and para-mononitrotoluenes

The literature reports several hazardous reactions involving the mononitrotoluenes. According to Bretherick (Ref 5, p 530), the

Table 2
Selected Properties of Ortho- and Para-Mononitrotoluenes (Refs 6, 8 & 9)

Isomer	Color and Crystn Form	MP, °C	BP, °C	d, g/cc	Refr Index	Solubility	CA Registry No
2-Nitrotoluene	(i) ndles (ii) crystn (yel liq)	-9.55 -2.9	221.7	1.629	1.5450	benz, ethanol and petr eth	[88-72-2]
4-Nitrotoluene	yel ortho cryst	54.5	238.3	1.1038 at 75/4°	1.5382	acet, benz, chlf ethanol and eth V sol in w	[99-99-0]

Table 3
Selected Thermochemical and Energetic Properties of Ortho- and Para-Mononitrotoluene
(Refs 2, p 269 and 2a)

MNT Isomer	Q_C^v , kcal/mole	Q_f , kcal/mole	$Q_{\text{nitration}}$, kcal/mole	Flash pt, °F
Ortho	897.0	+ 2.0	+25.3	223
Para	888.6	+10.4	+33.7	223

reaction of NaOH in a vac still resulted in an expln during the processing of the ortho isomer. It is believed that this expln was caused by the formation of the solid *aci*-Na salt of ortho-MNT, and its heating to expln decompn by the exothermic reaction of the acids present. He also reports on explns of the para isomer during vac distln shut-down. Also reported by both Bretherick and the Natl Fire Protection Assn (Ref 11, p 491M-283) are the violent explns occurring when the para isomer reacts at either 80° or, in some cases, 160°, with 93% sulfuric acid

Sax (Ref 2a) considers both ortho- and para-MNT moderately toxic. The threshold limit value for both isomers is 5ppm in air, or 28mg/m³ of air. The isomers are absorbed thru the skin

MNT has been used by the Japanese Army in an expln compn called "Ennayaka" (See in Vol 7, J22-R) along with K chlorate (80) and castor oil (5%)

Dick and Curton (Ref 2b) have patented a safety blasting expln, contg from 12–25% MNT, which will not burn at atm press, has the power of 50% blasting gelatin, and a reduced tendency to ignite firedamp. Nuscher and Slater (Ref 2c) claim in their patent the use of MNT as a sensitizer for mixts of TNT in DMF, together with AN and other fuel elements. Yamazaki et al (Ref 3) claim an expln compn contg a MNT which will safely shatter concrete structures quietly. Thus, the expln incorporates K bromide (70), MNT (10), Al-Mg alloy (20) and chlorosulfonated polyurethane binder (1 p by wt). Alm & Samuelsen's patent (Ref 9a) suggests the use of a MNT as fuel, together with AN and Ca nitrate, to form a free-flowing percussion cap sensitive expln

Lownds' patent (Ref 7), on the other hand,

suggests the use of MNT in plastic incendiary cords and fuses, which he claims are relatively safe to manuf in a continuous manner by extrusion as rods on a central fabric or metal rod. These demonstrate an avg burning time of 271.2±1.2–4.2sec/m. Thus, a suspension contg a 20–40% soln of MNT in DNT (4), polyvinylchloride in DNT (12.8), plus MNT (3.2), is mixed with 150-micron K perchlorate (20) and 50-micron ferromanganese (60%). The mixt, when extruded as a 2mm rod on a flexible cotton support, heated and then cooled, forms the pyrot item of interest

Refs: 1) Beil 5, 318 & 323, (158 & 160), [243 & 246] & {730 & 736} 2) Urbański, Vol 1 (1964), 268–81 2a) Sax (1968), 976 2b) W. Dick & O.A. Curton, "Safety Blasting Composition with a Metal Formate as a Fuel", USP 3356546 (1967) & CA 68, 41782 (1968) 2c) E.H. Nuscher & J.D. Slater, "Explosive Compositions Containing Ammonium Nitrate and an Organic Sensitizer Dissolved in Dimethylformamide", USP 3676235 (1972) & CA 77, 154631 (1972) 3) T. Yamazaki et al, "Explosive Composition", JapP 74-12690 (1974) & CA 81, 43633 (1974) 4) G. Olah, "Fundamental Study of Toluene Nitration", Case Western Reserve Univ, Cleveland, Contract DAA-21-72C-0528 (1975) 5) Bretherick (1975), 530–31 6) Merck (1976), 863 (No 6470) 7) C.M. Lownds, "Incendiary Compositions", SAfrP 7401060 (1975) & CA 84, 152905 (1976) 8) CondChemDict (1977), 619–20 9) R. Meyer, "Explosives", Verlag Chemie, NY (1977), 119 9a) O. Alm & E. Samuelsen, "Percussion Cap-Sensitive Powdered Explosive", NorwegianP 136356 (1977) & CA 87, 186704 (1977) 10) Anon, "Hndbk of Chem & Physics" (1978), C-527 11) Anon, "Fire Protection Guide on Hazardous Materials", Seventh Edn, NFPA, Boston (1979), 491M-283

Table 4
Selected Properties of the Dinitrotoluene Isomers

Property	Isomer and Value						Refs
	2,3-	2,4-	2,5-	2,6-	3,4-	3,5-	
Boiling pt, °C	—	300(decompn)	—	—	—	sublimes	30
Brisance by 200g Sand Test: Sand, g (crushed)	—	19.3	—	—	—	—	15
Crystallographic Data:							
Type	cryst	monocl prisms	ndles	rhomb ndles	ndles	rhomb ndles	31; 3
β , °	—	54	—	—	—	—	3
α , °	—	32	—	parallel to "C" axis	—	—	3
d, g/cc	1.2625	1.521	1.282 @ 111°	1.2833 @ 111° or 1.538 @ RT	1.2594 @ 111°	1.2772 @ 111°	15; 31 24
Deflagration pt, °C	—	360	—	360	—	—	24
Deton Vel, m/sec	—	3850 @ d 1.10 g/cc (in steel tubes of 28-30mm diam), & 5900 @ d 1.52 g/cc (60mm tube)	—	—	—	—	8
Explosion Temp, 5 sec, °C	—	310 (decompn)	—	—	—	—	15
Friction Sensy, Pendulum Test:							
Steel Shoe	—	unaffected	—	—	—	—	15
Fiber Shoe	—	unaffected	—	—	—	—	15
Gas Evolved on Explosion, l/kg	—	602	—	—	—	—	24
Heat of Combustion, Q_c^v , kcal/mole	860.5	853.7	856.1	855.2	860.8	853.9	13
Heat of Explosion, Q_e^v , kcal/kg	—	1056	—	1085	—	—	24
Heat of Formation, Q_f^v , kcal/mole	+24.3	+31.3	+28.7	+29.6	+24.0	+30.9	13
Heat of Sublimation, ΔH_{sub} , kcal/mole	—	23.8	—	—	—	—	14k
Heat of Vaporization ΔH_v , kcal/mole	—	22.9	—	23.5	—	—	29
Hygroscopicity at 25° and 100% RH, %	—	(277.15–323.15°K)	—	(240.15–298.15°K)	—	—	15

(Continued)

Table 4 (Continuation)

Selected Properties of The Dinitrotoluene Isomers

Property	Isomer and Value						Refs
	2,3-	2,4-	2,5-	2,6-	3,4-	3,5-	
Impact Sensy, 2-kg wt, mkg/cm ² (cm), 50% pt	—	20 (70)	—	18.8 (66)	—	—	2;3
KI Test at 65.5°, minutes	—	+60	—	—	—	—	15
Melting pt, °C	59.5	71	50.5, 52.5	66	58.3, 59.3	93	24;31
Power by: a) Trauzl Test, cc (% TNT)	—	190 (64)	—	—	—	—	2;3
b) Ballistic Mortar, % TNT	—	71	—	—	—	—	15
Refraction Index	—	1.442	—	1.479	—	—	31
Rifle Bullet Impact Test	—	100% unaffected	—	—	—	—	15
Sensitivity to Initiation by:							
1) Detonating charge, mixing							15
a) Pb Azide	—	0.20	—	—	—	—	
b) Tetryl	—	0.25	—	—	—	—	
2) Shock, NOL Gap Test, 50% pt							
a) No cards	—	24 (1.50g/cc)	—	—	—	—	14j
b) P ₀ , kbar	—	105 (1.50g/cc)	—	—	—	—	14j
Storage: Method	—	Dry	—	—	—	—	15
Hazard Class (quant-dist)	—	12	—	—	—	—	15
Compatibility group	—	D	—	—	—	—	15
Thermal Conductivity, cal/sec/cm/°C at d 1.322g/cc	—	6.28 x 10 ⁴	—	—	—	—	15
Thermal Ign by Steel Sleeve:							
Limiting Diam, mm	—	1	—	—	—	—	24
Time to Ign, secs	—	49	—	—	—	—	24
Combustion Time, secs	—	21	—	—	—	—	24
Vac Stability at 120°	—	0.04	—	—	—	—	15

m-Nitro- α -Dinitro Toluene (or m-Nitrophenyl-dinitromethane). $(O_2N)C_6H_4.CH(NO_2)_2$, $C_7H_5N_3O_6$; mw 227.15; N 18.50%; OB to CO_2 -73.96%; white crystals (from ethanol); mp 124–25° (decompn). Prepn is by treating phenyldinitromethane with concd nitric acid (d 1.52g/cc). The compd is a more powerful expl than TNT. It forms expl salts whose expl power decreases with the increasing atomic wt of the cation: **Potassium** salt (yel crystals), **Silver** salt (golden-yel crystals), **Barium** salt (yel ndles), **Lead** salt (orange-yel ppt), and **Ammonium** salt (yel flakes)

Refs: 1) Beil, not found 2) M. Milone & A. Massa, "A New Isomer of Tritol", *GassChimItal* **70**, 196–201 (1940) & *CA* **34**, 4571 (1940)

The Dinitrotoluene Isomers (DNT).

$CH_3.C_6H_3(NO_2)_2$, $C_7H_5N_2O_4$; mw 182.14; N 15.38%; OB to CO_2 -114.4%; pale yel crystals.

V sol in acet and benz; sl sol in ethanol, eth and w. Addnl selected properties of each of the six isomers of DNT are given in Table 4. The quant soly of the 2,4-isomer in selected solvents is presented in Table 5

Note: The 2,4- and 2,6-isomers are the isomers of choice for current ordn usage; however, the other isomers are also of interest, as they usually coexist to some extent in the yield of many of the DNT prepn procedures, and thus have been incorporated in a variety of expl and proplnt formulations

The CA Registry Nos for the DNT isomers are: 2,3- [602-01-7]; 2,4- [121-14-2]; 2,5- [619-15-8]; 2,6- [606-20-2]; 3,4- [610-39-9] and 3,5- [618-85-9]

History of the Preparation of the Dinitrotoluenes. Urbański (Ref 13, pp 285–86) reports that "... The principal reaction products in the nitration of toluene are the isomers: 2,4- formed from o- and p-nitrotoluenes, and 2,6- formed from o-nitrotoluene. From m-nitrotoluene the 2,3-, 3,4- and 3,6-isomers are formed, ...

Dinitrotoluene (2,4-) was first obtained by Beilstein and Kuhlberg ... in 1870. However, it may be that "dinitrobenzene", m.p. 71°C obtained in 1841 by St. Claire-Deville ... by the nitration of "nitrobenzene" prepared from light

Table 5
Solubility in Selected Solvents of 2,4-Dinitrotoluene (Ref 15)

1) Solubility: g/100g of the following substances:

30%		Nitroglycerin		Water	
Ethyl Alcohol					
°C	%	°C	%	°C	%
25	0.16	20	30	22	0.027
35	0.29			50	0.037
45	0.49			100	0.254
55	0.77				
60	1.03				

2) Solubility at 15°C, in:

Solvent	%	Solvent	%
$CHCl_3$	65.076	C_2H_5OH (absolute)	3.039
CCl_4	2.431	Ether (absolute)	9.422
C_6H_6	60.644	Acetone	81.901
Toluol	45.470	Ethyl acetate	57.929
CH_3OH	5.014	CS_2	2.306
C_2H_5OH (96%)	1.916	Pyridine	76.810

oil, was in fact dinitrotoluene. As Rosenstiel . . . found in 1872 p-nitrotoluene yields only one product of dinitration, viz. the 2,4-isomer, while o-nitrotoluene gives in addition another isomer, the structure of which he did not determine.

The first indication of the existence of the other dinitrotoluene isomers can be found in the Limpricht's work He was able to isolate from the nitration products the 3,6-isomer, besides the 2,4- and 2,6-isomers. In 1903 Zaloziecki . . . nitrated the aromatic fraction of Galicia oil and isolated the 2,4- and 3,6-nitrotoluenes.

Beilstein and Kuhlberg nitrated the m-nitrotoluene in 1873 and obtained the 3,4-isomer.

The data were confirmed by Häussermann and Grell . . . in 1894. They stated that besides the isomers already mentioned, the 3,5-isomer was also isolated. Several authors questioned the presence of the latter isomer in the nitration products. For example, Sirks . . . reported that nitration of m-nitrotoluene resulted in the formation of the 3,4-, 2,3-, and 3,6-isomers, but not the 3,5-isomer.

Gibson, Duckham and Fairbairn . . . have carried out more detailed studies, in which they established that the following proportions of isomers are formed in the nitration of various mononitrotoluenes (Table 58):

Table 58
Nitration of Nitrotoluene Isomers

Substance being nitrated	Dinitrotoluene isomers, content %				
	2,4-	2,6-	3,4-	2,3-	3,6-
o-Nitrotoluene	67	33	—	—	—
p-Nitrotoluene	100	—	—	—	—
m-Nitrotoluene	—	—	55	25	20

De Beule . . . carried out the most extensive study of nitration of m-nitrotoluene. He found the product was composed of 54.6% of 3,4-dinitrotoluene, 30.6% of 2,3-dinitrotoluene, 13.0% of 2,5-dinitrotoluene, and 1.8% of 3,5-dinitrotoluene. Thus he confirmed the formation of 3,5-isomer.

The crude dinitrotoluene consists (according to de Beule) of the following isomers:

2,4-dinitrotoluene	76.1%
2,6-dinitrotoluene	19.8%
3,4-dinitrotoluene	2.25%
2,3-dinitrotoluene	1.23%
2,5-dinitrotoluene	0.54%
3,5-dinitrotoluene	0.08%

. . . Kobe, Skinner and Prindle . . . reported their extensive studies on the nitration of o- and p-nitrotoluenes to dinitrotoluene. They concluded that the most favourable parameters of the nitration of o- and p-nitrotoluenes differed somewhat from each other. Thus the concentration of mixtures for nitrating o-nitrotoluene might vary within a wider range, especially with regard to the quantity of sulphuric acid. Also, lower temperatures may be applied for the nitration of o-nitrotoluene.

According to these authors, the following conditions are the most favourable in the nitration of 200 g of nitrotoluenes:

	o-Nitrotoluene	p-Nitrotoluene
Nitric acid weight	theoretical	theoretical
Sulphuric acid weight	250–350 g	350 g
Sulphuric acid concentration	90%	90%
Temperature	50°C	65°C
Reaction time	15–20 min	15–20 min
Yield	100%	98% . . .

Kobe and Fortman (Ref 11), in summing up their work and the work of other investigators on the *mixed acid* nitration of the MNT's (o-MNT in particular) through 1961, conclude: 1) “. . . the products of the nitration of o-nitrotoluene are 2,4- and 2,6-dinitrotoluene in the ratio of 2 to 1, respectively, with only trace quantities of the other possible isomers formed . . .”; 2) “. . . the mechanism of dinitration is the same as that for mononitration; the nitronium ion is the nitrating agent . . .”; 3) “. . . at least 90%, and perhaps all, of the nitration reaction takes place in the acid phase of mixed acid, two-phase nitrations . . .”; 4) “. . . nitration rates are independent of the ratio of the phase volumes when based on the volume of the acid phase . . .”; and 5) “. . . the rate of dinitration approaches zero when the mole ratio H₂O to H₂SO₄ approaches unity . . . some active aromatic compounds have exhibited considerable nitration rates beyond this acid ratio limit . . .”

Olah and Lin (Ref 16) conclude from their

work using the *nitronium ion* in a variety of solvents that "... nitration of ... nitrotoluenes shows high positional and substrate selectivity, indicating 'late' (in the reaction coordinate), ie, arenium ion-like nature of the transition states of highest energy. This is also reflected with increasingly predominant para orientation (related to the methyl group) in the nitration of nitrotoluenes. This observation is significantly different from the generally high ortho/para nitrotoluene isomer ratios observed in the nitration of toluene ... care must be exercised in mechanistic considerations when attempting to compare nitration of aromatics of widely varying electronic donor nature, such as ... toluene with ... nitrotoluenes ...". Because of the almost instantaneous nitration of MNT's and high yields of DNT's using their procedure, it was chosen as the procedure of choice in the article for the lab prepn of all DNT isomers except for the 3,5-isomer

Preparation of the DNT Isomers

A. Laboratory Procedures for Pure Isomers

1) **2,3-Dinitrotoluene** is produced in approx 42% yield employing the procedure of Olah and Lin (Ref 16) using the nitronium ion in a suitable solvent. Thus, 0.0125 mole of m-MNT is dissolved in 25cc of nitromethane. Into this soln, 2.5 millimole of nitronium hexafluorophosphate, dissolved in 25cc of nitromethane, is added dropwise. The reaction mixt is vigorously stirred and the temp kept constant at 25° during the reaction time of 1 hr. The reaction mixt is then quenched with w, extracted with eth, washed with 5% Na bicarbonate soln, dried over Mg sulfate, concd, and sepd out from other co-formed DNT isomers (2,5-, 3,4-, and 3,5-) by either gas-liq chromatography (Ref 7) or fractional crystn

2) **2,4-Dinitrotoluene** is produced in approx 99.8% yield using much the same procedure as for the 2,3-isomer, except that p-MNT is used as the starting material

3) **2,5-Dinitrotoluene** is produced in 18.6% yield by the procedure used for the 2,3-isomer

4) **2,6-Dinitrotoluene** is produced in 39.9% yield by the procedure used for the 2,3-isomer, except that o-MNT is used as the starting material

5) **3,4-Dinitrotoluene** is produced in approx

60% yield by a modified Olah and Lin procedure. The modification consists of using m-MNT dissolved in 96% sulfuric acid, dropwise addn of 25cc of the nitronium ion (2.5 millimoles of nitronium hexafluorophosphate) dissolved in 96% sulfuric acid, and subsequent quenching of the reaction soln on ice

6) **3,5-Dinitrotoluene** is best produced by the method of Conklin and Pristera (Ref 10) in 50 to 65% yield. The procedure involves dinitrating para-acetyl-toluidide, hydrolyzing the product to the amine, and diazotizing the amine in boiling ethanol. Thus, 20g of aceto-para-toluidide are added slowly to 200cc of commercial white-fuming nitric acid. Since the solid dissolves rapidly with evolution of considerable heat, care has to be exercised to maintain the mixt at a temp of less than 15°. This is accomplished using an ice-salt bath. When all the toluidide has been added and complete soln has occurred, the soln is poured, with stirring, into about 2ℓ of ice-w. The pptd 3,5-dinitro-aceto-para-toluidide is filtered off at once and thoroughly washed with w. Rapid filtration and thorough washing are necessary to prevent deterioration of the product by the dil nitric and nitrous acids. The product thus obtained is hydrolyzed with a 50/50 mixt by vol of sulfuric acid and distilled w as follows: The pale yel acetyl compd is slowly added to a well-stirred acid soln on a steam bath. After about one hour, the soln is cooled and dumped with stirring into about a ℓ of crushed ice. The mixt is then filtered using a Buchner funnel and washed with w. The material obtained is washed free of acid, with a minimum of w so as not to dissolve too much of the material. When this material, consisting of 3,5-dinitro-para-toluidine, is sufficiently acid free, it is air dried. The 3,5-dinitrotoluene is prepd from the 3,5-dinitro-para-toluidine by diazotizing using a boiling alc soln as follows: 5g of the finely-divided substance are suspended in a mixt of 100ml of abs alc and 25cc of strong sulfuric acid (sp gr 1.84). When the effervescence ceases, w is added and the dinitrotoluene is filtered off and air dried. It is then purified to remove traces of a tar-like material formed during the diazotizing by heating on a steam bath for 30 mins with 70% nitric acid. The soln is then poured into w, the material filtered, washed with w, air dried, and then crystd from benz, carbon disulfide, or petr eth

B. Industrial Preparation of 2,4-Dinitrotoluene

According to Urbański (Ref 13, pp 288–89):
 "... In industrial practice, mononitrotoluene is nitrated with a mixture of composition ranging:

HNO ₃	28–34%
H ₂ SO ₄	60–64%
H ₂ O	5–8%

The manufacture of dinitrotoluene at the Griesheim factory (I.G. Farbenindustrie), described below, may serve as an example.

4000 kg of *o*- and *p*-nitrotoluene (the latter should be melted) is run into the nitrator at a temperature of 25°C and 55°C respectively. Then 5500 kg of mixed acid of composition:

HNO ₃	33.5%
H ₂ SO ₄	60.7%
H ₂ O	5.7%

are run in, so that the temperature in the case of *p*-nitrotoluene follows the curve (Fig. 64)

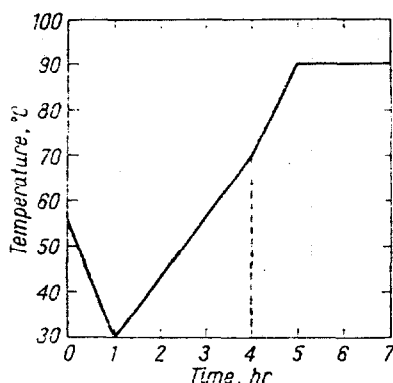

Fig 64 Temperature change during the nitration of *p*-nitrotoluene (Ref 13)

When all the acid has been added over a period of 4 hr, heat is applied to raise the temperature to 90°C which is held for a further 2 hr. A test sample is steam distilled and no smell of nitrotoluene should be present in the distillate.

If mononitrotoluene is detected, a further 50 kg of mixed acid is added and heating is continued at 90°C for a further half an hour. The contents of the nitrator are diluted with 350–400l. of water to give a waste acid of 73% H₂SO₄ containing ca. 0.1% HNO₂.

After settling, the waste acid is run into the washing tank (a lead-lined vessel of 12m³ capacity) where the acid from three or four previous nitrations is collected and washed with sufficient crude nitrotoluene and *o*-nitrotoluene to form

one batch for nitration to dinitrotoluene. After settling, the washed waste acid is collected in the acid storage tank. The nitrotoluene is pumped or blown to the nitrator.

In the washing tank, a stainless steel vessel of 12m³ capacity, dinitrotoluene is washed with 4000 l. hot water and the wash water is blown to drain. 4000 l. of hot water are then run in and while stirring, sufficient solid NaOH is added to obtain a neutral reaction. The wash liquor is discarded and the product is washed with water to remove excess NaOH.

The molten dinitrotoluene is run into the vacuum dryer, and heated at 120°C at a pressure of 15 mm Hg for 5 hr. It is tested for moisture by heating a small amount in a test-tube and looked for condensation on the side of the tube. The material is made up into solid blocks or flakes . . .

Dinitrotoluene, prepared by nitrating *p*-nitrotoluene, and free from *m*-nitrotoluene, should not melt below 64.5°C. It should contain not less than 96% of 2,4-dinitrotoluene. . ."

The US Mil Spec for Dinitrotoluene is MIL-D-204A with amendment 2 (PA), dated 21 November 1975 (Ref 17). The specified color requirement is light yel thru buff (by visual inspection). The required physical and chemical properties are shown in Table 6

Sax (Ref 14) considers the DNTs to be highly poisonous. They can be absorbed by the skin or inhaled causing anemia, methemoglobinemia, cyanosis and liver damage. The threshold tolerance level is 1.5mg/m³ of air. They are considered to be a moderate fire and expln hazard (Ref 23)

A review of the literature reveals the following pertinent information on properties and potential uses of the DNTs:

Price et al (Refs 14i & 14j) conclude from their data that 2,4-DNT should be characterized as an expl. They state that it is a group 1 expl that can be dead pressed with moderate ease; that its infinite diam deton vel is approximated by D_1 (mm/microsec) = 1.96+2.913(d) (see Fig 1); and that the detonatability and shock sensy of 3 and 10 micron 2,4-DNT are near those of prodn lots of high bulk d Nitroguanidine and DATB

Rontsch (Ref 14q) claims that safety in production of expls contg DNT is greatly enhanced when the mixing operation is conducted as follows: The components of the expl are placed

Table 6
US Military Specification Acceptance Criterion for Dinitrotoluene (Ref 17)

Property	Values		Footnote
	Max	Min	
Solidification Point, °C	70.5	65.5	a
	Percent		
Acidity (as sulfuric acid)	0.01	—	b
Alkalinity	none	—	c
Alcohol or benz insoluble	0.1	—	d
Moisture and volatile matter	0.25	—	e
Granulation thru a US No 16 (1.18mm) sieve	—	95	f

Footnotes to Table 6:

- a— by noting the highest temp (from 15 sec interval observations) at which solidification occurs of a vigorously stirred molten 40–50g sample using a 76mm partial immersion thermometer, No 93C (ASTM), of 60–90°C range
- b— by titrating to a bromothymol end pt, using 0.01N aq NaOH, the sulfuric acid present in a 10g sample dissolved in benz-pure w (30/100cc)
- c— an excess is indicated by a definite alkaline reaction of the bromothymol blue in “b—”
- d— by gravimetric techniques in which the hot benz or ethanol insol residue of a 10g sample is filtered off into a tared filtering crucible
- e— by (gravimetrically) detg the loss in wt of a 5g sample after vac desiccation at 25°C
- f— by weighing the amount remaining of a 100g sample left on the sieve after the sieve has been shaken by hand or by a tap machine for 3 mins

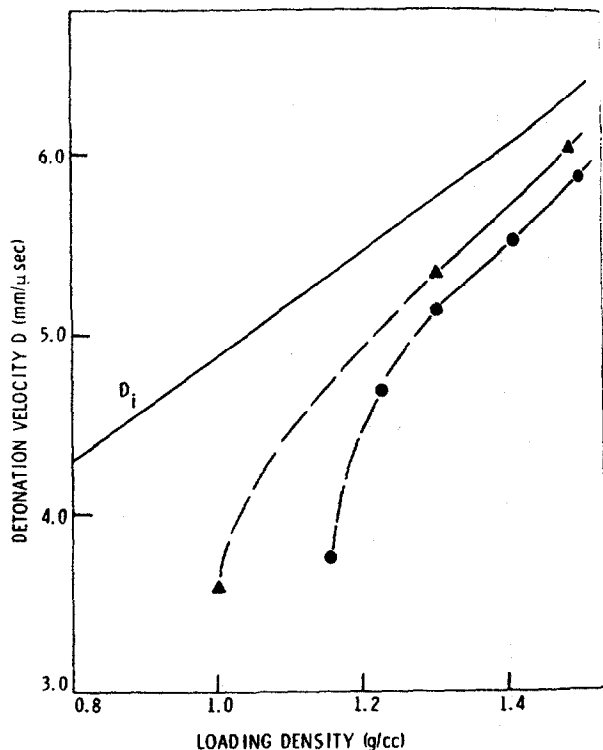

Fig 1 Pattern of Detonation vs Density Curves for 2,4-DNT (diam=7.62cm; diam=5.08cm) (Ref 14j)

in an open-top container which is then covered with a much larger container that contains the mixing app. The entire assembly is inverted, the expl mixed, the assembly reinverted, and the two containers separated. In an example, an expl compn which contained AN, Nitroglycol, TNT, DNT, sawdust and colcothar, was safely processed

Nagaishi et al (Ref 26) detd the role of DNT in a typical three component concrete demolition compn contg Pb chromate as the oxidizing agent, DNT as the fuel, and Al as the thermic energy source. They concluded that the chromate accelerates the decomn of the DNT and reacts with the Al. DNT initially generates a large vol of gases which serve to raise the temp sufficiently to oxidize the Al, with the accompanying alumina-thermic reaction creating a vastly increased expansion of the gases evolved by the DNT, and the desired concrete fracturing effect

The DNTs have been used in comml expl mixts since at least 1931 (Ref 15). In Ger, mining expls contg DNT are called “Donarit”. (see in Vol 5, D1531-L & R). Belgrano (Ref 6) lists compns and properties of a number of such mining expls, examples of which are shown in Table 7

Table 7
Examples of European Mining Explosive Compositions Containing Dinitrotoluene (Ref 6)

Composition and Some Properties	Designation											
	1	2	3	4	5	6	7	8	9	10	11	12
DNT	17.0	22.5	17.0	16.0	19.0	20.0	27.8	21.0	23.0	23.0	10.0	9.0
Collodion Cotton	0.5	0.5	0.5	0.5	1.0	1.0	1.2	0.5	0.5	1.0	0.8	1.0
Am perchlorate	36.0	36.0	—	—	—	—	43.0	40.0	42.5	40.0	44.0	40.7
Am nitrate	—	—	42.0	45.0	—	50.5	—	—	—	—	—	—
K perchlorate	—	—	16.5	16.5	—	—	—	—	—	—	—	—
Na chlorate	—	—	—	—	59.0	—	—	—	—	—	—	—
Na nitrate	25.0	25.0	18.0	15.0	—	14.5	28.0	37.0	31.0	35.0	32.2	30.3
TNT	3.5	3.75	6.0	7.0	—	7.0	—	—	3.0	—	5.0	3.0
PETN	18.0	12.25	—	—	21.0	7.0	—	—	—	—	—	—
Wood flour	—	—	—	—	—	—	—	—	—	—	1.0	3.0
Naphtha	—	—	—	—	—	—	—	1.5	—	1.0	—	—
NG	—	—	—	—	—	—	—	—	—	—	7.0	7.0
Ca silicide	—	—	—	—	—	—	—	—	—	—	—	6.0
Oxygen Balance, %	+0.28	+0.21	+0.46	—	—	—	—	—	—	—	—	—
Trauzl Test, cc	460	400	350	315	335	335	340	360	400	420	430	480

Examples of the use of DNT in permissible expls are to be found in Vol 3, C452-L to C454-R under "Italian . . . ; Russian Permissible Explosives". More current usage of DNT in expls is delineated next

Logan and Knott's patent (Ref 14a) suggests that the deton vel in Sprengel type expls (qv in this Vol) can be controlled by using varying amts of DNT as the organic fuel (Table 8). Additionally, the expl produced is claimed to be a w-resistant solid of high strength and sensitive to a No 6 blasting cap. For example, a soln of 30.2p by wt of AN is dissolved in 41.8p of 98% nitric acid, cooled to 23° and seeded with AN.2HNO₃ crystals, then mixed with 28p of DNT at 60°. At 18° this mixt sets up in 20–25 secs. Upon cooling to 5°, the expl is hard and dry

Ferguson's patent (Ref 14b) suggests the use of 2–15% DNT as the sensitizer, along with 30–75% of an inorganic oxidizer salt expl (such as AN), 8–25% w, and 0.2–5% of a thickener such as guar gum to form an aq slurry type expl. In another patented formulation, that of Griffith (Ref 14c), DNT is again used as the principal sensitizer of an expl gel, along with Nitrostarch as the subsidiary sensitizer, together with AN and optional addnl ingredients. A typical compn

Table 8
Control of the Detonation Velocity of Sprengel Type Explosives by Addition of Varying Amounts of DNT (Ref 14a)

Inorganic Nitrate Component	DNT Content, %	Deton Vel, m/sec ^a
AN.HNO ₃	28	2715
AN	40	1870
Dinitrobenzene	40	2790
AN	47	2110
KNO ₃	56	3240

Footnote to Table 8:

a—2000g 2.5" diam samples detonated using a 160g Pentolite primer

is reported as Nitrostarch (22.00), DNT (4.15), AN (54.20), Na nitrate (14.80), nut meal (2.00), flake Al (2.50), DPA (0.05) and No 5 oil (0.30%). Measured parameters of this formulation are d 1.195g/cc, deton vel >3418m/sec, and a Bal Pendulum value of 11.2. Slurried as well as granular expl mixts are claimed. Ferguson's invention (Ref 14d) claims the use of 2,4-DNT (15) and flake Al (85%) as sensitizers in a series of twenty-one rubber-like expl slurries which,

in general, are comprised of w (8–25), an inorg oxidizer (30–75), and crosslinked guar gum (0.2–5%), with the balance of the compn consisting of the DNT-Al sensitizer

Malkovsky et al (Ref 14e) claim a stable, fluid and impact insensitive expl gel contg NG (48–60), DNT (5–9), inorg nitrate (30–45), starch (< 2) and w (< 6 wt %) which can be poured into a ground hole and expld by conventional means. Again, DNT is suggested as a sensitizer in Fearnow's expl compns (Ref 14g). He claims (as usual) safe, stable, economical "water gel" expl compns of d 1.0–1.5g/cc contg no self-expl or metallic sensitizers, yet reliably detonatable at low temps. Thus, AN (47.8), w (6.1), $\text{KSbC}_4\text{H}_4\text{O}_7$ (0.025), sugar (5.0), egg albumin (0.2), formamide (1.8), 26° tech DNT oil (11.0), Na nitrate (18.1), guar gum (1.0), and Na dichromate (1.0 lb) are mixed together using a turbine-type mixer at 140–170°F. The mixt is reported as having a deton vel of 5100 m/sec when detonated in a 5" diam unconfined polyethylene bag at 56°F. Shinohara and Oishi's patent (Ref 14h) claims a liq expl contg DNT. Typically, DNT:MNT (1:1) (10), AN (69.9), a nonionic surfactant (0.1), Al (10), and w (10%) are mixed together to form a slurry with a d of 1.45g/cc and a deton rate of 4500m/sec, using 40g of Dynamite as the primer. Enoksson's invention (Ref 14l) again suggests the use of DNT, this time as the desensitizer (and fuel). Thus, a mixt contg NG/Nitroglycol 40/60 (25.1), DNT (7), TNT (1.8), NC (1.3), AN (coated with 0.07% of a 50/50 mixt of stearylamine/stearylammmonium stearate, a hydrophobic coating which traps air bubbles of sufficient size to improve initiation sensy) (58), Na nitrate (6), wood meal (0.7) and chalk and pigments (0.1%), provides a gel reported as being extrudable under a force of approx 3.4 dynes/cc. Mager's invention (Ref 14m) is worthy of mention. Prepn of the patented expl is accomplished by adding small amts of a soln contg 60l of 66% nitric acid and 16.4kg of a mixt of DNT and TNT to a soln contg Na nitrate (69), w (6), urea (36) and propionic acid (3kg), with stirring to yield a crystn expl of d \sim 1–1.05g/cc, having a deton transfer of 3cm and a deton vel of 3220m/sec. Baldwin's invention (Ref 14n) consists of an expl gel of d 1.0g/cc used with a Gelnite base charge for quarry blasting, contg AN (70.98),

DNT (12.0), w (14.0), expanded polystyrene (2.5), guar gum (0.5) and borax (0.02%). Lingens and Kluensch (Ref 14o) claim an expl, useful in w-filled boreholes, contg AN (68.5), Na nitrate (15.0), TNT (6.0), powdered Al (2.0), guar flour (2.0), Ca stearate (0.5) and DNT (6.0%) with a d of 1.27g/cc and a Trauzl Pb block expansion of 360cc. Glier and Thiard modified TNT (85–98) with DNT (0.5%) in their invention (Ref 14p) to produce an expl coated with 1–10% wax (melting at 60–72°) having a d of 1.46g/cc, a deton vel of 3900m/sec, and (it is claimed) with a better shock resistance than conventional TNT. A unique contribution is the expl invented by Yamazaki and Akimato (Ref 16a) which, they claim, will shatter a concrete block while emitting a low noise level. The formulation consists of 100 wt p of a mixt of K bichromate (85) and ferrosilicon (15%), with 10 wt p of DNT. Agranovich et al (Ref 20) claim the prepn of plastic Ammonites (see Vol 1, A307-R) by mixing powdered Ammonite components with MNT, DNT, xylene, and nitrobenz, and gelatinizing the mixt with methacrylic acid polymer. Sakai et al (Ref 21) claim in their patent a storage-stable high deton vel slurry expl contg DNT (5), sorbitan monostearate (0.05), AN (72.45), w (12), guaiac gum (0.5), urea (5), and ethylene glycol (5 p). They report a deton vel of 4610m/sec at 20° after three months storage of the compn. Mitsui et al (Ref 25) report on a procedure for making mixts of liq expls such as NG/Nitroglycol in a 62:38 wt % ratio, safe to handle until needed. The liq expls are desensitized by mixing with both DNT and polyethylene glycol in suitable ternary mixt ratios of DNT/polyethylene glycol/NG-Nitroglycol, such as 50/21.4/28.6 or 57.1/14.3/28.6 wt %. Sensitization is accomplished by shaking the ternary mixts with w to remove the polyethylene glycol. The non-aq portions then show sufficient expl sensy, according to the authors, to be used in both underwater situations and in spray-on-sand techniques with success. Bluhm's patent (Ref 27) claims the invention of a nonshrinking expl primer compn, sensitive to both No 6 caps and detonating cords, syringe injectable to form complex primer shapes weighing up to 50g in one operation. Typically, a mixt of finely granulated PETN (50), DNT (10), and TNT (40%) is melted with agitation at

90–100° to a smooth creamy texture suitable for syringe injection manufg procedures. In another invention, that of Shiino et al (Ref 28), a pliable expl is claimed contg DNT. Polyacrylamide (2), w (15), AN (6), hydrazine nitrate (28), and DNT (9g) are mixed to form the claimed expl having a sp grav of 1.33, an expl vel of 3400m/sec, and an impact sensy of “no explns” when dropped from a ht of 50cm, six times without deton. A blasting slurry which can be prepd on site has been patented by Cook (Ref 30). Molten DNT, contg 0.5 to 10% glacial acetic acid (905), an aq soln of AN (3330), a mixt of NHCN[CaNO₃(~77.5) plus AN (~7.5) and w (~15%)] (800), w (550), and HP-8 gum (25g), are emulsified at 65° and then mixed with prilled AN (500g), a trace of foaming agent plus 1 g of a crosslinking agent in 10g of acetic acid. The ingredients are vigorously stirred and allowed to set-up after pouring into the site work hole. The inventor reports that such a slurry (d 1.38g/cc) was successfully detonated three days after mixing. Preller et al (Ref 33) claim a waterproof expl powder which can be deton at –20° by means of a fuse. Thus, a compn contg AN (50% < 100 microns) (79.0), DNT (8.0), Al (2.0), powdered Al foil (8.0), guar meal (20), and coal dust (1.0%) is produced with an OB of –8.0%. The inventors report a cartridge d of 1.12g/cc, waterproofness, and detonation using a 12g fuse at both RT and –20°

The 2,4- isomer of DNT is used in small arms proplnts as a coating to control the burning rate. Used as DNT-oil in larger calibers, it aids in reducing hygroscopicity. Also, in reducing the percent of volatiles present (and being expl in nature), it compensates to some degree for the loss of energy caused by incorporation of the explosively inert dibutylphthalate (or similar ingredient). Proplnts using the 2,4-DNT coating are termed “F.N.H.” and “N.H.”. See in Vol 6, F152-L & R, and in Vol 8, N25-R

Other examples of the use of DNT in proplnts are to be found in the reports listed as *Addnl Reports* at the end of this article. More current information from the open literature is given below. Small amounts of DNT are incorporated in the smokeless proplnt invention of Suyama and Wakabayashi (Ref 19). The proplnt grains are manufd by molding under w so as to prevent accidental deton. Further, it is claimed

that the d of the finished proplnt can be adjusted by varying the w temp used during the molding procedure. For example, 0.82, 0.80, 0.76, and 0.51g/cc densities are obtd when the molding process w temp is 10, 35, 60 or 80°, respectively. Thus, NC (57.95), NG (40.00), DNT (0.5) and eth centralite (1.75p) are kneaded in acet-ethanol soln and molded under w at any temp to obtn plate-like proplnts of varying d. An example of the use of DNT coating to modify the effect of temp on burning rate is given in Leneven's patent (Ref 22). Ten kg of septi-perforated proplnt grains (2.96mm diam x 3.3mm length) prepd conventionally by the solvent process, contg NC (13.3% N) (100), DPA (1.2) and K sulfate (0.5p), are glazed with 5g of graphite treated with three equal portions of a soln of 125g of 3,5-DNT in 1 kg of ethanol at 90°, tumbling with each portion for 40 mins at 60°; repeating with three increments of a soln of 180g of camphor in 800g of ethanol at 85°; then removing the solvent, soaking, drying and glazing the grains with 15g of graphite. The low temp coefficient effect is shown in firing tests conducted with a 20mm cannon at –54, 21 and 70° using a 90g projectile and 54.4g proplnt charges. The max press developed and projectile velocity at 25m from the muzzle were found to be 2998, 3681 and 4130 bars, and 1193, 1263 and 1284m/sec, respectively. Comparison with test values of solely camphor coated grains, viz, 3027, 3643 and 4817 bars and 1205, 1248 and 1312m/sec, respectively, at the test temps indicates an improved temp coeff for the doubly treated (DNT and camphor) proplnt

Refs: 1) Beil 5, 339–41, (167–68), [258–62] & {759–61} 1a) Beil 12, [975] 2) Blatt, OSRD 1085 (1942), 30–31 3) Blatt, OSRD 2014 (1944) 4) V.H. Williams & H.R. Wright, “Detonating Explosives”, USP 2407595 (1946) & CA 41, 286 (1947) 5) Anon, “Plastic Explosive”, FrP 947052 (1949) & CA 45, 3599 (1951) 6) Belgrano (1952), 118–21 & 286 7) Chi-Shaw Ling, “Note on the Purification of 2,4-Dinitrotoluene From Toluene by the Aid of Chromatography”, JChineseChemSoc 18, 135–36 (1951) & CA 46, 2965 (1952) 8) L. Médard, “Comparison of the Explosive Properties of Nitropolystyrene and the Dinitrotoluenes”, MP 34, 99–105 (1952) & CA 48, 4837 (1954) 9) Ibid, “Some Characteristics

- of the Dinitrotoluene Detonation in the Cylindrical Cartridge”, *CR* **241**, 1036–37 (1955) & *CA* **50**, 6049 (1956) 10) C. Conklin & F. Pristera, “Preparation and Physical Properties of Di- and Trinitrotoluene Isomers”, *PATR* **2525** (1958) 11) K.A. Kobe & J.T. Fortman, “Nitration of *o*-Nitrotoluene”, *IEC* **53**, (4), 268–74 (1961) & *CA* **55**, 27155 (1961) 12) P.F. Pokhil & L.D. Romodanova, “The Behavior of Dinitrotoluene in the Burning of Powder”, *Doklady AkadNauk* **128**, 133–35 (1959) & *CA* **56**, 10437 (1962) 13) Urbański, *Vol 1* (1964), 281–90 14) Sax (1968), 702 14a) H.A. Logan & R.F. Knott, “Nitric Acid Explosive Composition Containing an Inorganic Nitrate Oxidizer and a Nitrated Aromatic Compound”, *USP* 3306789 (1967) & *CA* **66**, 117566 (1967) 14b) J.D. Ferguson, “Aqueous Slurry Blasting Composition”, *USP* 3328217 (1967) & *CA* **67**, 83557 (1967) 14c) G.L. Griffith, “Gelatinized Dinitrotoluene-Nitrostarch Explosive Sensitizers”, *USP* 3399089 (1968) & *CA* **69**, 78897 (1968) 14d) J.D. Ferguson, “Nitrocarbonate Blasting Compositions Containing Flake Aluminum and Dinitrotoluene as Sensitizers”, *USP* 3356545 (1967) & *CA* **68**, 51485 (1968) 14e) K. Malkovsky et al, “Mixed Liquid Explosives”, *CzechP* 122929 (1967) & *CA* **86**, 41781 (1968) 14f) same as 14c 14g) P.W. Fearnow, “Aqueous Explosive Compositions”, *SAfricanP* 6803478 (1968) & *CA* **71**, 23401 (1969) 14h) M. Shinohara & K. Oishi, “Explosive Compositions”, *JapP* 6905720 (1969) & *CA* **72**, 4844 (1970) 14i) D. Price et al, “Explosive Behavior of Dinitrotoluene”, *NOL Rept* (1969) (AD-694944) & *CA* **72**, 91843 (1970) 14j) *Ibid*, “Explosive Characterization of Dinitrotoluene”, *Combstn&Flame* **1970**, 14 (1), 145–48 & *CA* **72**, 134811 (1970) 14k) C. Lenchitz et al, “Vapor Pressure and Heat of Sublimation of Three Nitrotoluenes”, *JChemEngData* **1970**, 15 (3), 401–03 & *CA* **73**, 49252 (1970) 14l) B.P. Enoksson, “Nitroglycerin-Nitroglycol Blasting Composition”, *USP* 3579392 (1971) & *CA* **75**, 38604 (1971) 14m) H.E. Mager, “Nitrotoluene Explosives”, *GerP* 2156815 (1972) & *CA* **77**, 64234 (1972) 14n) W.C.G. Baldwin, “Gelatinous Blasting Explosives”, *SAfricanP* 71043611 (1972) & *CA* **77**, 116523 (1972) 14o) P. Lingens & M. Kluenssch, “Ammonium Nitrate Explosive of High Waterproofness and Density”, *GerP* 2116353 (1972) & *CA* **78**, 32245 (1973) 14p) J. Glizer & R. Thiard, “Trinitrotoluene-Based Granulated Explosives”, *FrP* 2102642 (1972) & *CA* **78**, 74354 (1973) 14q) S. Rontsch, “Production of Explosives”, *USP* 3695953 (1972) & *CA* **78**, 74357 (1973) 14r) same as 14o 15) Anon, *Engrg Des Hdbk*, “. . . Properties of Explosives of Military Interest”, *AMCP 706-177* (1971), 116–18 16) G.A. Olah & H.C. Lin, “Aromatic Substitution . . . Selectivity of the Nitration of Nitro (Dinitro) . . . Toluenes from that of Benzene and Toluene”, *JACS* **96** (9), 1–7 (1974) & *CA* **80**, 81639 (1974) 16a) T. Yamazaki & T. Akimoto, “Explosive Composition”, *JapP* 7412690 (1974) & *CA* **81**, 93632 (1974) 17) Anon, “Dinitrotoluene for Use in Explosives”, *MIL-D-204A* (1975) 18) Bretherick (1975), 527 19) S. Suyama & M. Wakabayashi, “Molding of Smokeless Propellant”, *JapP* 74134814 (1974) & *CA* **83**, 134499 (1975) 20) B.D. Agranovich et al, “Plastic Ammonites”, *RussP* 72913 (1975) & *CA* **83**, 149792 (1975) 21) H. Sakai et al, “Slurry Explosive with High Detonation Velocity and Storage Stability”, *JapP* 7601614 (1976) & *CA* **84**, 166917 (1976) 22) L. Leneven, “Differential Glazing of Powders Based Only on Nitrocellulose”, *FrP* 2278658 (1976) & *CA* **85**, 179848 (1976) 23) *Cond-ChemDict* (1977), 312 24) R. Meyer, “Explosives”, *Verlag Chemie*, NY (1977), 86, 137, 140 & 280 25) S. Mitsui et al, “Liquid Explosives Containing Nitroglycerin as the Main Ingredient”, *KogyoKayaku* **1974**, 35 (3), 127–32 & *CA* **86**, 75472 (1977) 26) T. Nagaishi et al, “Reaction of Lead Chromate, Aluminum and Dinitrotoluene”, *KogyoKayaku* **1974**, 35 (1), 12–18 & *CA* **86**, 6877 (1977) 27) H.F. Bluhm, “Primer Composition for Use with Explosive Charges”, *USP* 4009060 (1975) & *CA* **86**, 173788 (1977) 28) K. Shiino et al, “Pliable Explosives”, *JapP* 76130518 (1976) & *CA* **86**, 92720 (1977) 29) P.A. Pella, “Measurement of the Vapour Pressure of TNT, 2,4-DNT, 2,6-DNT . . .”, *JChemThermody* **1977**, 9 (4), 301–05 & *CA* **87**, 11791 (1977) 30) M.A. Cook, “Stable Blasting Slurry”, *USP* 4084993 (1978) & *CA* **89**, 77158 (1978) 31) Anon, *Hndbk of Chem & Phys* (1978), C-524 32) Anon, “Fire Protection Guide on

Hazardous Materials", NFPA, Boston (1979), 49-142 33) H. Preller et al, "Ammonium Nitrate Explosive", GerP 2605632 (1977) & CA **91**, 23456 (1979)

Addnl Reports on the Use of DNT Not Used in this Article: A) C.S. Davis, "Develop Improved Caliber .50 Propellant of Modified Composition to Reduce Smoke", PATR **343** (1933) B) W.H. Rinckenbach, "Calorific Values of Smokeless Powders as Affected by Variations in Composition, Granulation, etc", PATR **673** (1935) C) C.S. Davis, "Development of Improved Propellant and Primer to Reduce Flash in Caliber .50 Ammunition (Ignition Study)", PATR **1672** (1947) D) W.H. Rinckenbach, "Study of Stability of Double-Base Propellants", PATR **1674** (1948) E) J.E. Rainier & W.M. Rowe, "Propellant for 2ES-40,000 Jato, T29", PATR **1692** (1948) F) N.S. Garman et al, "The Effect of Temperature Conditioning on Stability and Sensitivity Characteristics and the Chemical Composition of M1 and M6 Propellants Manufactured with Crude or Refined Dinitrotoluene", PATR **4841** (1975) (limited distrib)

α -Nitro-3,5-Dinitrotoluene (or Dinitrophenylnitromethane). $(\text{O}_2\text{N})_2\cdot\text{C}_6\text{H}_3\cdot\text{CH}_2(\text{NO}_2)$, $\text{C}_7\text{H}_5\text{N}_3\text{O}_6$; mw 227.15; N 18.50%; OB to CO_2 -73.96%; small yel cryst; mp 130° . V sol in hot ethanol, acetone, ethyl acetate, hot acetic acid and hot benz; not sol in C tetrachloride. Prepn is by the reaction of 2g of m-nitrophenylmethane (m-nitrotoluene) with 15g of mixed acid at 65° . Crystn of the product is accomplished by cooling the reaction mixt to 20° , and then drowning in ice-w. The crude product is then double recrystd from acetic acid. Dinitrophenylnitromethane ignites at 343° (when 0.5g is heated at a rate of $10^\circ/\text{min}$) and it is considered to be more shock sensitive than TNT (12cm using a 10kg wt versus 19cm for TNT) by Urbański (Ref 2)

Refs: 1) Beil, not found 2) T. Urbański, "The Nitration of Phenylnitromethane", CR **206**, 1122-24 (1938) & CA **32**, 4959 (1938)

The Dinitro Methoxy Toluenes. See in Vol 3, C556-R to C557-L under "Nitro Derivatives of Cresol". The CA Registry No for these compds is [50741-92-9]

4,6-Dinitrotoluene-3-Sulfonate, The Sodium Salt of. $(\text{NO}_2)_2\text{C}_6\text{H}_4\cdot\text{C}\cdot\text{SO}_3\text{H}^-\text{Na}^+$, $\text{C}_7\text{H}_5\text{N}_2\text{O}_7\text{NaS}$; mw 284.61; N 9.85%; OB to CO_2 -61.8%; white ndles. Sol in ethanol and w; insol in benz and eth. Prepn is by shaking finely powdered γ -TNT with a satd aq soln of Na sulfate in a stoppered bottle, and then allowing the mixt to stand for 24 hrs at RT. The product is then ethanol-washed, recrystd from hot ethanol, and dried in a vac desiccator. The salt deflagrates violently on heating

Refs: 1) Beil **5**, [268] 2) O.L. Brady et al, "Reactions of the Unsymmetrical Trinitrotoluenes", JCS **125**, 2400-04 (1924) & CA **19**, 475 (1925)

2,4,6-Trinitrotoluene. See in this Vol under "TNT"

The Unsymmetrical Trinitrotoluenes

These expl compds have the following common properties: Empirical formula, $\text{C}_7\text{H}_5\text{N}_3\text{O}_6$; mw 227.13; N 18.50%; OB to CO_2 -73.9%; pale yel in color; v sol in ethanol; sol in acet, benz and eth; not sol in w; non-hygroscopic. Prepn of all isomers is by nitration of m-MNT, with an alternate prepn noted where applicable. Specific properties are presented below under the individual compds. More information can be found in this Vol under "TNT" ("Unsymmetrical TNT Isomers")

2,3,4-Trinitrotoluene (β -Trinitrotoluene).

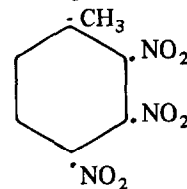

triclinic leaflets or prisms (from acet); mp 112° ; d 1.62g/cc

Decompn temp, $^\circ\text{C}$	282
Expln temp, $^\circ\text{C}$	302
Q_c^v , kcal/mole	834.7
Melting enthalpy, kcal/kg	25.8
	kJ/kg
	108
Energy of formation, kcal/kg	+34.2
	kJ/kg
	+143
Enthalpy of formation, kcal/kg	+15.9
	kJ/kg
	+67
Impact Sensy (Fig of Insensitivity)	92% PA

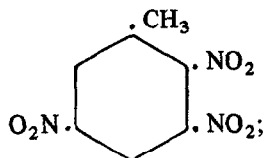
2,3,5-Trinitrotoluene (ϵ -Trinitrotoluene)

mp 97°. Prepn is from 3,5-dinitro-2-aminotoluene by diazotization and replacement of the diazonium group by a nitro group

Decompn temp, °C	283
Expln temp, °C	335
Q_C^V , kcal/mole	825.6
Melting enthalpy, kcal/kg	20.3
kJ/kg	108
Energy of formation, kcal/kg	-5.9
kJ/kg	-25
Enthalpy of formation, kcal/kg	-24.2
kJ/kg	-101
Impact Sensy (Fig of Insensitivity)	108% PA

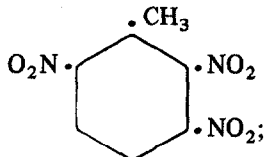
2,3,6-Trinitrotoluene (η -Trinitrotoluene)

mp 108, 111° (sep values). Prepn is from 2,6-dinitro-3-aminotoluene by diazotization and replacement of the diazonium group by a nitro group

Decompn temp, °C	280
Expln temp, °C	335
Q_C^V , kcal/mole	827.1
Melting enthalpy, kcal/kg	24.9
kJ/kg	104
Energy of formation, kcal/kg	+0.7
kJ/kg	+3
Enthalpy of formation, kcal/kg	-17.6
kJ/kg	-74
Impact Sensy (Fig of Insensitivity)	108% PA

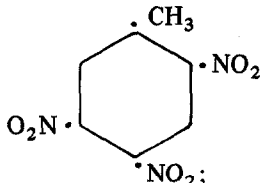
2,4,5-Trinitrotoluene (γ -Trinitrotoluene)

plates (from acet) or rhombic bipyramides; mp 104°; sp gr 1.620 at 20/4°

Decompn temp, °C	262
Expln temp, °C	290-310
Q_C^V , kcal/mole	827.4
Melting enthalpy, kcal/kg	26.3
kJ/kg	110
Energy of formation, kcal/kg	+2.0
kJ/kg	+8
Enthalpy of formation, kcal/kg	-16.3
kJ/kg	-68
Impact Sensy (Fig of Insensitivity)	102% PA

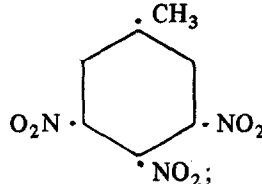
3,4,5-Trinitrotoluene (δ -Trinitrotoluene)

mp 132, 137.5° (sep values). Prepn is from 3,5-dinitro-4-aminotoluene by diazotization and replacement of the diazonium group by a nitro group

Decompn temp, °C	288
Expln temp, °C	313
Q_C^V , kcal/mole	825.6
Melting enthalpy, kcal/kg	21.2
kJ/kg	89
Energy of formation, kcal/kg	+13.0
kJ/kg	+54
Enthalpy of formation, kcal/kg	-5.3
kJ/kg	-22
Impact Sensy (Fig of Insensitivity)	95% & 102% PA (sep values)

Refs: 1) Beil 5, 172, 173, 347 & 349; [766 & 767] 2) Blatt, OSRD 2014 (1944) 3) Urbański, Vol 1 (1964), 326-37 4) R. Meyer, "Explosives", Verlag Chemie, NY (1977), 294

2,3,4,6-Tetranitrotoluene (2,3,4,6-Tetranitro-methyl benzene). $\text{CH}_3 \cdot \text{C}_6\text{H}(\text{NO}_2)_4$, $\text{C}_7\text{H}_4\text{N}_4\text{O}_8$; mw 272.15; N 20.59%; OB to CO_2 -47.03%; orange cryst; mp 135, 136.5° (sep values). Sol in chl_f; v sl sol in w. Prepn is in three steps: 1) the nitration of m-cresyl methyl ether to trinitro-m-cresyl methyl ether; 2) the replacement of the methoxy group with an amino group; and 3) the oxidation of the amino group to the tetranitrotoluene. Thus, the nitration of step 1 is carried out using concd nitric acid (sp

gr 1.52) with a 61% yield of 3-methoxy-2,4,6-trinitrotoluene; the methoxy group is replaced by reacting this compd with 1N ammonia in methanol and boiling for a short time to yield 95.9% of 3-amino-2,4,6-trinitrotoluene; the final oxidation step is accomplished by reacting $K_2S_2O_8$ with a soln of the amino compd of step 2 in concd sulfuric acid using vigorous stirring, and allowing the mixt to rise to a temp of 100° . Allowing the soln to cool overnight yields a ppt which is then washed with 50% sulfuric acid and finally with w. The crude product is recrystd from chlf. Tetranitrotoluene has a shock sensy of 50cm using a Kast appar with a 2-kg wt, and a Trauzl test value of 327cc using a 10g sample. It is considered to be more stable than Tetranitrobenzene (see Vol 1, B47-R to B49-R)

Refs: 1) Beil 5, [273] 2) A.F. Holleman, "2,3,4,6-Tetranitrotoluene", *Rec* 49, 501-02 (1930) & *CA* 24, 4275 (1930) 3) Blatt, *OSRD* 1085 (1942), 89 4) Urbański, Vol 1 (1964), 339-40

α,α -Dichloro- $\alpha,2,4,6$ -Tetranitrotoluene.

$(NO_2)_3C_6H_2.C(Cl)_2(NO_2)$, $C_7Cl_2H_2N_4O_8$; mw 340.93; N 16.43%; OB to CO_2 -32.85%; pale yel ndles; mp $133-34^\circ$ (decompn). Sol in warm methanol-w mixt. *CA Registry No* [60789-52-8]. *Prepn* is as follows: To a soln of $\alpha,2,4,6$ -tetranitrotoluene in tetrahydrofuran-w (3:1) is added <1 cc of 5N Na hydroxide, resulting in a red-colored soln. Chlorine gas is then bubbled into the red soln until its color changes to a light yel, and then an aq soln of hydrochloric acid (10:1) is added. The yel oil which separates after this addn is allowed to solidify, and the pure product is recrystd from methanol-w. *Ref* 2 terms this compd an expl

Refs: 1) Beil, not found 2) M.E. Sitzmann et al, "Fluoronitromethane as an Alkaline Nitrating Agent. *Prepn* of $\alpha,2,4,6$ -Tetranitrotoluene from 2,4,6-Trinitrotoluene", *JOC* 42 (3), 563-64 (1977) & *CA* 86, 72083 (1977)

$\alpha,2,4,6$ -Tetranitrotoluene.

$(NO_2)_3C_6H_2.CH_2(NO_2)$, $C_7H_4N_4O_8$; mw 272.15; N 20.58%; OB to CO_2 -47.03%; yel cryst; mp $116.5-118^\circ$. Sol in a 2:1 tetrahydrofuran-methanol mixt. *CA Registry No* [35113-75-8]. *Prepn* is by reacting TNT with fluoro-

trinitromethane in a 2:1 soln of tetrahydrofuran-methanol at -40° . The product is salted out using a 1:1.5 w-methanol soln of K hydroxide at 0° , and then hydrolyzed with dil hydrochloric acid. The pptd product is then filtered off, w-washed and dried. Primary recrystn is from benz-hexane, with further recryst from methanol-w. The yield is reported as 89%. *Ref* 2 terms this compd an expl. The compd's deep red expl K salt, **Potassium- $\alpha,2,4,6$ -Tetranitrotoluene** is formed using a tetrahydrofuran-methanol soln of K hydroxide and $\alpha,2,4,6$ -tetranitrotoluene, and precipitating the salt with eth. The salt is reported to be v sensitive to impact and heat

Refs: 1) Beil, not found 2) M.E. Sitzmann et al, "Fluorotrinitromethane as an Alkaline Nitrating Agent. *Prepn* of $\alpha,2,4,6$ -Tetranitrotoluene from 2,4,6-Trinitrotoluene", *JOC* 42 (3), 563-64 (1977) & *CA* 86, 72083 (1977)

Fluorotoluene and Derivatives. See in Vol 6, F142-L and the following *Addnl Refs:* M.J. Kamley, "Explosives and/or Propellant Compounds Containing a Fluorodinitromethyl Group", *USP* 3624129 (1971) & *CA* 76, 33936 (1972) [The inventor claims a proplnt-expl compd, **Fluorodinitrotoluene**. $C_6H_5.CF(NO_2)_2$, $C_7H_5FN_2O_4$; mw 200.14; N 14.00%; OB to CO_2 -19.99%. *Prepn* is by treating a DMF soln of K- α,α -dinitrotoluene with perchloryl fluoride and concd sulfuric acid at 15° . The yield is reported as 25%]

Toluene Sulfoxide Perchlorate.

$(C_6H_5.CH_2.SO_2H)ClO_4$, $C_7H_8O_5ClS$; mw 239.66; OB TO CO_2 -73.44%; mp 120° . V sol in acetic acid, ethyl acetate, and dimethylketone; insol in petr eth and benz; decompd by ethanol and w; v deliq in a humid atm. *Prepn* is by reaction of toluenesulfoxide with perchloric acid. The perchlorate detonates at 125°

Refs: 1) Beil, not found 2) J. dePascual Teresa, ". . . Reaction of Perchloric Acid with Sulfoxides . . .", *AnalesSocExpanFisyQuim* 45B, 235-44 (1949) & *CA* 44, 3935 (1950)

Picryl Hydroxylamine Toluene. See in Vol 7, H297-R under "2,4,6-Trinitro-3-Hydroxylaminotoluene"

Written by H. L. HERMAN

3,5-Dinitro-2-Bromo-p-Toluic Acid Azide.

$\text{CH}_3 \cdot \text{C}_6\text{HBr}(\text{NO}_2)_2 \cdot \text{CO} \cdot \text{N}_3$, $\text{C}_8\text{BrH}_4\text{N}_5\text{O}_5$; mw 330.07; N 21.22%; OB to CO_2 -63.02%; ndles (from a mixt of benz plus gasoline); mp 101° . Prepn is by reaction of 3,5-dinitro-2-bromo-toluic acid with Na azide in aq acet. The azide explds when heated rapidly
 Ref: Beil 9, [335]

2,3,6-Trinitro-p-Toluic Acid. (2,3,6-Trinitro-4-methyl benzoic acid). $\text{CH}_3 \cdot \text{C}_6\text{H} \cdot \text{CO}_2\text{H}(\text{NO}_2)_3$, $\text{C}_8\text{H}_5\text{N}_3\text{O}_8$; mw 271.16; N 14.44%; leaflets (from dil ethanol); mp $230-31^\circ$. V sol in ethanol, eth and benz; sol in hot w; sparingly sol in petr eth. Prepn is by the oxidation of 2,3,5-trinitro-p-xylyl with Cr trioxide in concd sulfuric acid at $50-60^\circ$. The compd forms the expl salt **Silver-2,3,6-Trinitro-p-Toluic Acid**; $\text{AgC}_8\text{H}_4\text{N}_3\text{O}_8$; mw 378.02; N 11.12%; OB to CO_2 -42.33%; ndles (from w); mp, explds on heating. Prepn is by reacting an aq soln of the Ag ion with an alc soln of the acid.
 Ref: Beil 9, [335]

3,4,6 (or 3,5,6) -Trinitro-o-Toluic Acid (3,4,6 (or 3,5,6) - Trinitro-2-methyl benzoic acid). $\text{CH}_3 \cdot \text{C}_6\text{H} \cdot \text{CO}_2\text{H}(\text{NO}_2)_3$, $\text{C}_8\text{H}_5\text{N}_3\text{O}_8$; mw 271.16; N 14.44% (ndles from dil ethanol); mp $201-02^\circ$, decompn at higher temps. V sol in ethanol and eth; sl sol in hot w. Prepn is by oxidation of 3,4,6-trinitro-o-xylyl with chromic-sulfuric acid at $40-50^\circ$. The compd forms an expl silver salt, **Silver-3,4,6 (or 3,5,6) -Trinitro-o-Toluic Acid**. $\text{AgC}_8\text{H}_4\text{N}_3\text{O}_8$; mw 378.02; N 11.12%; OB to CO_2 -42.33%; ndles (from w); mp, explds on heating. Prepn is by reacting an aq soln of the Ag ion with an alc soln of the acid
 Ref: Beil 9, [323]

The Toluidines (Tolylamines, Aminomethylbenzenes, Aminotoluenes or Methyl anilines). See in Vol 1, A264-R to A265-R under "Aminotoluenes and Derivatives" and the following *Addnl Refs and Derivatives*. The use of p-toluidine as a solid hybrid rocket fuel is reported in the literature: 1) R.H. Schmucker, "Theoretical and Experimental Contributions to Hybrid Rocket Propulsion", *Raumfahrtforschung* 1970,

14 (s), 193-202 & CA 74, 128310 (1971) [The use of p-toluidine and p-aminophenol in a ratio of 30:70 as fuel, with nitric acid as oxidizer in a hybrid rocket is reported] 2) A. Beckers & G. Jander, "Ignition and Combustion of Hybrid Propellant Combinations with Hypergolic Additives", *ErdoelKohleErdgasPetrochemBrennst-Chem* 1972, 25 (7), 400-01 & CA 78, 99928 (1973) [In a hybrid rocket ignition study, ignition and re-ignition optimum conditions were ascertained relative to combustion chamber parameters of geometry, pressure (mass flow) and oxidizer injection system. Fuel platelets 2-3mm thick, prepd from a 50:50 p-toluidine/p-aminophenol mixt were used with nitric acid as oxidizer] 3) W.M. Schaur & R.H. Schmucker, "Development of a Hybrid Rocket", *Raumfahrtforschung* 1975, 19 (1), 27-38 & CA 83, 100273 (1975) [Optimum proplnt is reported as concd or 100% nitric acid as the liq oxidizer with p-toluidine 30 and p-aminophenol 70% as the solid fuel]

The O-, M- and P-Toluidino-Diazo-Copper Complexes. $(\text{N}_3)_2\text{Cu} \cdot \text{C}_7\text{H}_7\text{NH}_2$; mw 254.78; N 38.49%; grn-brn cryst; mp, ortho- 123° (explds), meta- $157-60^\circ$ (explds), para- 135° (explds). Sol in ethylenediamine and acids. Prepn is by reacting Cu(II) azide with the appropriate toluidine isomer. The isomers have an impact sensy of 10cm, using a 1-kg wt
 Refs: 1) Beil, not found 2) Gmelin, Syst Nr 60, Teil B, Lieferung 1 (1958) 3) A. Cirulis & M. Straumanis, *JPraktChem* 162, 307-28 (1943) & CA 38, 1969 (1944)

Toluidine Chlorate. $\text{CH}_3 \cdot \text{C}_6\text{H}_4 \cdot \text{NH}_2 \cdot \text{HClO}_3$; mw 191.62; N 7.31%; OB to CO_2 -133.58%. The chlorates turn grey on exposure to air; when exposed for any length of time they turn black. Two toluidine chlorate isomers have been reported:
o-Toluidine Chlorate. White plates from ethanol; mp, explds ca 88° . Prepn is by adding chloric acid slowly (dropwise) to an excess of the ortho isomer until the product crystals make their appearance. *Caution* - avoid an excess of chloric acid - even traces of the free acid decomp the salt explosively at RT. The product

crysts are then filtered off, washed thoroughly with eth and benz, and finally recrystd from ethanol. The ortho isomer ignites with an expl flash when a flame is applied

p-Toluidine Chlorate. Long white crysts; mp, explds at 125° evolving a copious quantity of white fumes. Prepn is by slow dropwise addition of aq chloric acid to an ethereal soln of p-toluidine, taking care to keep the mixt on the alkaline side because, as in the prepn of the ortho compd, an excess of the acid will produce expl decompn. After evapn of the eth at RT, the cryst product is washed with eth and benz, and then recrystd from ethanol. The salt ignites with a flash on exposure to flame
Refs: 1) Beil **12**, 782, 783, 856 & 896, (374, 398, 411 & 412), [433 & 488] 2) R.L. Datta & J.K. Choudhury, *JACS* **38**, 1079-86 (1916) & *CA* **10**, 1749 (1916)

Toluidine Perchlorate. $C_7H_{10}ClNO_4$; mw 207.62; OB to CO_2 -115.6%. Three toluidine perchlorate isomers have been reported:

o-Toluidine Perchlorate. $o-MeC_6H_4NH_2.HClO_4$; carbonizes without melting on heating, expln temp 260° (Refs 1 & 4); *CA Registry No* [41195-12-4]. It was prepd by neutralizing the base with aq perchloric acid (Ref 2). Samples were packed into tubes, ignited, and the change of burning rate with press measured. The following results were obtained:

Press in Atm	Equation for the Change of Burning Rate with Press
1-18	$u = 0.1p^{0.85}$ cm/sec
18-130	pulsation occurred
130-400	$u = 8.2 \times 10^{-3}p^{1.25}$ (Ref 6)

Condensation of the salt with aq formaldehyde gave a polymer which can be used as a proplnt binder (Ref 5)

m-Toluidine Perchlorate. $m-MeC_6H_4NH_2.HClO_4$; mp 200° with charring, expln temp 300° (Refs 2 & 4); *CA Registry No* [18720-58-6]. It was prepd by the interaction of m-toluidine hydrochloride with Ag perchlorate (Ref 4). The change of burning rate with press was measured in the same way as above, results:

Press in Atm	Equation for the Change of Burning Rate with Press
1-11	$u = 0.08p^{0.8}$ cm/sec
11-100	pulsation occurred
100-400	$u = 2.2 \times 10^{-3}p^{1.46}$ (Ref 6)

p-Toluidine Perchlorate. $p-MeC_6H_4NH_2.HClO_4$; expln temp 278° (Refs 3 & 4); *CA Registry No* [14796-13-5]. It was prepd by the same procedure as used for the meta isomer (Ref 4). The change of burning rate with press was measured in the same way as above, results:

Press in Atm	Equation for the Change of Burning Rate with Press
1-18	$u = 0.075p^{0.87}$ cm/sec
18-19	pulsation occurred
90-400	$u = 2.8 \times 10^{-3}p^{1.45}$ (Ref 6)

Refs: 1) Beil **12**, (374) 2) Beil **12**, (398) 3) Beil **12**, (411) 4) R.L. Datta & N.R. Chatterjee, *JCS* **115**, 1008 (1919) 5) T.S. Briggs, *Particle* **2**, 20 (1959) & *CA* **54**, 5089 (1960) 6) A.E. Fogel'zang et al, *FizGoreniyaVzryva* **8**, 257 (1972) & *CA* **78**, 45833 (1973)

Toluidine Picrate. See in Vol 8, P284-R under "o-Toluidine Picrate"

Dimethyltoluidines and Derivatives. See in Vol 5, D1375-L to D1376-R

The Dinitro Ortho- Meta- and Para-Toluidines (Aminodinitrotoluenes, x,x-Dinitro-x-amino-toluenes, x,x-Dinitro-x-methyl anilines or x,x-Dinitro- (o-, m-, p-) -toluidines). $CH_3.C_6H_2-NH_2(NO_2)_2$, $C_7H_7N_3O_4$; mw 197.17; N 21.32%; OB to CO_2 -109.55%. V sol in acet; fairly sol in RT ethanol, eth and acetic acid; sl sol in concd hydrochloric acid

The Arthur D. Little compilation (Ref 3) and Ref 3a term these compds expls. Their prepn and individual properties are presented in Table 1

The principal methods of synthesis of the aminodinitrotoluenes are as follows: 1) Ammonolysis of trinitrotoluenes with excess ethanolic ammonia at reflux or 25°; 2) ammonolysis of hydroxy, alkoxy or halodinitrotoluenes; 3) reduction of trinitrotoluenes with hydrogen

Table 1
Synthesis and Properties of the Dinitrotoluidines (Refs 2, 4 & 5)

Nomenclature	Form	MP and (Decompr) Temp, °C	Preparation		Impact Sensy, cm ⁻²
			Method	Starting Compd	
Dinitro-Ortho-Toluidines					
2-Amino-3,4-dinitrotoluene	crysts	131–131.5	4	4-nitro-aceto-o-toluidines	–
2-Amino-3,5-dinitrotoluene	yel-orange crysts	215–217, 217–218 (320)	Hydrolysis with concd sulfuric acid at 110°	3,5-dinitro-2- [N-(4-toluene- sulfonyl)] toluene	>180
2-Amino-3,6-dinitrotoluene	brilliant orange prisms	148–151, 151 (300)	1	2,3,6-TNT	>180
2-Amino-4,5-dinitrotoluene	colorl ndles	191–191.5	4	4-nitro-aceto-o-toluidide	–
2-Amino-4,6-dinitrotoluene	crysts	175–176, 173–174 (307)	3 5	2,4,6-TNT 2-methyl-3,5-dinitrobenzoic acid	>180
2-Amino-5,6-dinitrotoluene	deep yel ndles	216	4	6-nitro-aceto-o-toluidine	–
Dinitro-Meta-Toluidines					
3-Amino-2,4-dinitrotoluene	golden yel ndles	94 (280)	1	2,3,4-TNT	>180
3-Amino-2,5-dinitrotoluene	rust colored flakes	127–128 (350)	5	2,5-dinitro-3-methylbenzoic acid	>180
3-Amino-2,6-dinitrotoluene	crysts	134	1	2,3,6-TNT	–
3-Amino-4,5-dinitrotoluene	large, brn-yel ndles	141	4	5-nitro-aceto-m-toluidide	–
5-Amino-2,4-dinitrotoluene	crysts	197–199, 196.5–197.5 (320)	1	2,4,5-TNT	>180
5-Amino-2,3-dinitrotoluene	orange-yel plates	165	4	5-nitro-aceto-m-toluidide	–
Dinitro-Para-Toluidines					
4-Amino-3,5-dinitrotoluene	golden spangles	176–177, 172 (250)	1	3,4,5-TNT	>180
4-Amino-2,3-dinitrotoluene	large yel prisms	125.5–126	Hydrolysis with Na hydroxide	2,3-dinitro-p-toluidide	–

(continued)

Table 1 (continuation)

Nomenclature	Form	MP and (Decompn) Temp, °C	Preparation		Impact Sensy, cm ^a
			Method	Starting Compd	
4-Amino-2,6-dinitrotoluene	crysts	171–172, (325)	3	2,4,6-TNT	169
4-Amino-2,5-dinitrotoluene	dk red ndles	190–191	4	2-nitro-aceto-p- toluidide	—

Footnote to Table

a-all samples detd as 50% positive values from 25 shots on a BM appar using a 2.5-kg wt and sample wts of 35±2 mgs

sulfide in dioxane or ethanol solvent using an ammonia catalyst; 4) nitration of mononitrotoluidines and derivatives using concd nitric acid; and 5) reacting hydrazoic acid (Na azide in sulfuric acid) with dinitrotoluic acids, ie, the Schmidt reaction

Rastogi and Bisht (Ref 3a) made combustion studies on hybrid proplnts consisting of o-, m- and p-toluidine nitrates with aniline-formaldehyde polymer as solid fuels, and red fuming nitric acid as oxidizer. They found that the results fitted a burning rate equation of the type, $r_b = a(G)^v$, where a and v are constants and G is the mass velocity. The authors conclude that the heterogeneous combustion reaction is diffusion controlled, and its rate is dependent on particle size

Refs: 1) Beil 12, 749, 757, 758, 851, 878 & 1009; (361, 365, 396, 409 & 442); and [413, 414, 462 & 479] 2) R.A. Morton & A. McGookin, JACS, 901–11 (1934) & CA 28, 6122 (1934) 3) Anon, "Punch Card Recording of Data on Explosives", Vol III, Arthur D. Little, Inc, Cambridge, Mass (1961) 3a) R.P. Rastogi & M.M.S. Bisht, "Combustion Processes Occurring Between Solid Fuels and Liquid Oxidizers", IndianJChem 1971, 9 (4), 333–38 & CA 75, 8053 (1971) 4) W.H. Dennis et al, JChemEngrgData 20, 202–03 (1975) & CA 83, 42943 (1975) 5) A.T. Nielsen, "Reduction and Ammonolysis Products Derived from Isomeric Trinitrotoluenes Synthesis and Chemical Stability of the Aminodinitrotoluenes", NWC-TP-5933 (1977)

Toluol-Ammonal. An Ital variety of Ammonals used during WWII. See in Vol 1, A291-R

4-o-Tolylazo-1-Naphthylamine Dinitrate.

$C_{17}H_{18}N_3 \cdot 2HNO_3$; mw 327.40; N 21.40%; OB to CO_2 -146.61%; ndles. The nitrate salt of 4-o-Tolylazo-1-Naphthylamine explds with a bright flame on warming to about 100°

Refs: 1) Beil, not found 2) L. Casale & M. Casale-Sacchi, "Salts of Some Aminoazo Compounds", Gazz 45, 490–50 (1915) & CA 10, 604 (1916) 3) L. Casale, "The Nitrates of Aminoazo Compounds", Gazz 45, 397–405 (1915) & CA 10, 1862 (1916)

O-, m-, and p-Tolyl Copper. $CH_3 \cdot C_6H_5 \cdot Cu$, C_7H_7Cu ; mw 154.69; the o- and p-isomers are pale beige microcryst powds, while the p-isomer is a yel microcryst powd; mp, all isomers expld strongly on exposure to O_2 at 0°, and expld weakly on heating above 100° in a vac. Sol in most org solvents. Prepn is by dropwise addn of an ethereal soln of o-, m-, or p-tolyllithium to an ethereal soln of cuprous bromide at 0°. Yields: o- is 50%, m- is 60–70%, and p- is 90%

Refs: 1) Beil, not found 2) A. Camus & N. Marsich, "Substituted Phenylcopper (I) Compounds", JOrganometalChem 1968, 14 (2), 441–64 & CA 70, 4256 (1969)

Tonita (Span). See under "Spanish Commercial Explosives of Nonpermissible Type" in Vol 3, C442-L, and under "Spanish Explosives and Ammunition" in this Vol

Tomahawk (BGM-109), Cruise Missile. Known originally as the Submarine-Launched Cruise Missile (SLCM), Tomahawk is being developed

in both strategic and tactical forms, for launching from aircraft and surface installations as well as from submerged submarines

The submarine or surface launched strategic weapon is turbofan-powered, with a solid propellant tandem rocket booster and nuclear warhead. Conversion to tactical role involves substitution of tactical guidance, a conventional HE warhead, and a turbojet cruise engine in place of the turbofan

Length with booster 6.40m (5.49m without); body diameter 0.53m; launch wt (approx) 1814 kg; cruising speed (strategic, approx) 885km/hr; strategic range over 2775km; tactical range over 555km

Refs: 1) M.J.H. Taylor & J.W.R. Taylor, "Missiles of the World", Charles Scribner's Sons, NY (1976), 151-52 2) R.T. Pretty, Ed, "Jane's Weapon Systems-1977", Franklin Watts Inc (1976), 24 & 69

Tonite (Fulmicoton nitré de Faversham in Fr). A series of Brit commercial blasting expls manufd by the Cotton Powder Co, Ltd at Faversham from 1874 thru the early 20th century

The first mixt, *Tonite No 1*, was patented in 1874 by Trench, Faure and Mackie, and contained NC (pulped) 51.6 and Ba nitrate 48.4%. This mixt was designed not to develop poisonous gases such as CO on functioning, supposedly containing sufficient oxygen for complete combustion. This was proven not to be the case, however, as was shown in tests conducted by Abel in Engl and Sarrau and Vieille in Fr

A second formulation, *Tonite No 2*, contained NC (pulped), K & Na nitrates, charcoal and S. A third formulation, *Tonite No 3*, patented by Trench in 1889, consisted of NC (pulped) 14.55 to 19, m-DNB (replaced by TNT about 1900) 13.2 to 13, and Ba nitrate 72.25 to 68%

Toward the end of the 19th and beginning of the 20th century, Tonites were used quite extensively in commercial blasting operations (as in the construction of the Manchester Canal), as well as for such military purposes as charging torpedoes

Tonites were also manufd in the USA by the Tonite Powder Co of San Francisco, and in Belg by the Société Cooppl at Wetteren. The following compn was used by the Belg Corps of

Engineers (le génie militaire): NC (pulped) 50, Ba nitrate 40 and K nitrate 10%

Refs: 1) Daniel (1902), 769-71 2) Gody (1907), 464-65 3) Anon, "Treatise on Ammunition", War Office, HMSO, London (1915), 40-41 4) Marshall 1 (1917), 570 5) Thorpe 4 (1940), 465

Tonka. A liq rocket fuel (see under "Liquid Propellants" in Vol 7, L36-R). Ref 1 states that it consisted of 1 p triethylamine and 2p xylydine, while Ref 2 lists its ingredients as aniline plus dimethylaniline as the fuel with nitric acid as oxidizer

Refs: 1) J. Fauveau, MP 31, 300 (1949) 2) R. Meyer, "Explosives", Verlag Chemie, NY (1977), 355

"Toothpaste" Explosives. Expls which can be extruded from a tube or caulking gun much in the manner of toothpaste

PicArns developed a formulation contg RDX 84, di (2-ethyl-hexyl) sebacate 6, polyisobutylene 1, and SAE No 10 motor oil 9%. It was extrudable at temps slightly below 20°F and did not exude on storage at 140°F. It was odorless, non-toxic, non-hygroscopic, and chemically stable. The expl gave the same Sand Test value as Composition C-3 (see Vol 3, C484-R), was insensitive to friction and rifle bullet impact, and was comparable in impact sensitivity to TNT

It could be extruded to any desired length thru orifices of various sizes and shapes, and could be detonated high order (rate of deton 7423m/sec) with a US Army Corps of Engineers Special Blasting Cap when in ribbon form 1/4" thick, 3/4" to 1" wide, and in lengths well over 50'

Among many other application areas, the US Navy utilized this expl for salvaging ships sunk in harbors. They extruded the material from a caulking gun on the bead of a weld. When detonated, it would break the bead free from the plate, thus allowing salvage of the unscathed plate

See also under "Composition C-4 or Harri-site" in Vol 3, C485-L, "PEP-3" in Vol 8, P137-R, "Picarmite" in Vol 8, P265-R, and "RIDE" and "RIPE" in this Vol

Refs: 1) A.L. Forchielli, PATR _____ (Feb 1951) (unpublished) 2) A. Rubin & G. Silvestro, PicArnsGenLabRept 51-H1-1826 (1951) 3) K.G. Ottoson, "Conference on Explosives", PicArns, Dover (Dec 1955), 13

Torpedo. A marine weapon consisting of an underwater vehicle, a warhead, and a control mechanism, which can be a homing unit, an impact or proximity device or a time fuse. Initially developed as a surface-to-surface weapon, the torpedo has evolved into a diversified class of weapons capable of submerged launching or targeting — or both

The propulsion mechanism usually consists of an electric motor which, with the associated power storage, takes up most of the torpedo's cylindrical structure. The warhead is generally a HE one, though nuclear warheads are available for some systems. Torpedoes were initially equipped with time or impact fuses, and therefore required precise linear aiming. Magnetic fuses were introduced during WWII, but performance improved much more significantly with the introduction of acoustic homing units. These use an active or passive Sonar to detect the target, a programming unit to compute path corrections, and an autopilot which actuates the control gear. Wire-guided torpedoes, such as the US Mk 37, are controlled by command impulses to target and require either target visibility or the Sonar tracking of both torpedo and target

Torpedoes now equip submarines, surface vessels and aircraft, and are often dual purpose in that they can be used against both surface vessels and submarines. The introduction of fast nuclear submarines has resulted in the development of deep-diving high speed torpedoes, such as the US Mk 46 Mod 1 and 2, reported to have solid propellant driven turbines, instead of the more common electric motors

Subroc (qv in this Vol) represents a new approach in weapons launched from submarines. It emerges on the surface, flies to the target as a rocket and then drops a nuclear depth charge which is inertially guided to the target area (Refs 1 & 2)

Table 1 lists the current (1978) torpedo roster of many major sea powers, taken from Ref 5

Refs: 1) E.W. Seifert, "Evolution of the Torpedo", Ordn 39, 720-25 (1955) 2) E. Luttwak, "A Dictionary of Modern War", Harper & Row, NY (1971), 203 3) Anon, "Torpedo Propulsors. A Review of Design Procedures, Manufacture, Inspection, and Testing", Rept ORDHAC-TR-74-1 (1974), (AD 777092) 4) R.I. Haught, "Role of Industry in Future Torpedo System Development", Rept DSMS-PMC-75-2 (1975), (ADA 026979) 5) J.E. Moore, Ed, "Jane's Fighting Ships, 1978-79", Franklin Watts, NY (1978), 788-89

Torpedo Friction Test. See under "Friction Sensitivity Tests (Quantitative)" in Vol 6, F205-R to F206-L

Torpex. A castable HE developed in Engl during WWII for use as a filler in warheads, mines and depth bombs. Several variations in the compn of Torpex exist, with the following having been used in service munitions:

	Torpex 2 (unwaxed)	Torpex 2 (waxed)	Torpex 3
RDX, %	42	41.6	41.4
TNT, %	40	39.7	39.5
Al powder, %	18	18.0	17.9
Wax, %	—	0.7	0.7
Ca chloride, %	—	—	0.5

The following discussion is pertinent to Torpex 2 (unwaxed); the waxed version was formulated to reduce sensitivity to impact and bullet sensitivity tests; the Ca chloride in Torpex 3 was an attempt to remove traces of moisture which proved to be deleterious on storage (see below)

Torpex 2 (unwaxed) is suitable for melt loading (d 1.82g/cc when cast) and is a silvery-white solid. At 15° it has a specific heat of 0.24cal/g/°C and thermal conductivity of 0.00094cal/sec/cm/°C. Its coeff of thermal expansion at ordinary temps is 0.00047inch/inch/°C. When the molten expl undergoes solidification, there is a volume decrease of 6%. Its compressive strength is 2100-2300psi and Young's Modulus is 1.38 x 10⁶psi, both values at a d of 1.77g/cc. It is nonhygroscopic when

Table 1
Torpedoes (from Ref 5)

No	Name/Note	Length	Diameter	Weight	Speed knots	Range	Explosive charge	Guidance	Target/Role	Carrier
FRANCE										
Z 16	Now probably obsolete	720cm	550mm	1700kg	30	10km	300kg	Preset plus Pattern	A/S	S/M
E 14	Acoustic Torpedo	429.1cm	550mm	900kg	25	5.5km	200kg	Acoustic	A/Surface (up to 20 knots) +S/M at shallow depth	S/M
E 15	Acoustic Torpedo	600cm	550mm	1350kg	25	12km	300kg	Acoustic	A/Surface 0-20 knots + S/M at shallow depth	S/M
L 3	Acoustic Torpedo	430cm	550mm	910kg	25	5.5km	200kg	Acoustic	A/S 0-20 knots up to 300m depth	S/M only
L 4	Acoustic Torpedo	313cm inc parachute stabilizer	533mm	540kg	30	—	—	Acoustic	A/S up to 20 knots	Airborne
L 5 Mod 1	Multi purpose		533mm	1000kg	35	—	—	Direct Attack or Programmed Search	—	Ship
L 5 Mod 3	—	—	533mm	1300kg	35	—	—	—	—	S/M
GERMANY (Federal Republic)										
SST 4	Wire Guided Torpedo	635cm inc 46cm wire casket	533mm	—	—	—	260kg	Wire Guided Active Passive Sonar Homing	A/Surface	Ship or S/M
—	See Eel	639cm	533mm	1370kg	35/23	13/28km	—	Wire guided, active/ Passive Sonar Homing	A/S	S/M or FPBs
—	Sut	613 & 670cm inc wire casket	533mm	—	—	—	—	—	—	S/M or ship
—	Seal	639cm inc wire casket	533mm	1370kg	—	—	260kg	Wire	—	Ships
—	Seeschlange	400cm inc wire casket	533mm	—	—	—	100kg	Wire	A/S	—

(continued)

Table 1 (continuation)

No	Name/Note	Length	Diameter	Weight	Speed knots	Range	Explosive charge	Guidance	Target/Role	Carrier
ITALY										
G 6E	Kangaroo	620cm	533mm	—	—	—	—	Wire Guided	Obsolescent	—
A 184	—	600cm	533mm	—	—	—	—	Wire Guided Active/Passive Sonar	A/S or A/Surface	Ship or S/M
A 244	—	270cm	324mm	—	—	—	—	Homing Course & Depth	—	Ship or aircraft
SWEDEN										
Type 41	—	244cm	400mm	250kg	—	—	—	Passive Homing Sonar	Limited A/Surface or A/S	S/M
Type 42	—	244cm + 18cm wire section	400mm	270kg	—	—	—	Passive Homing Sonar or Wire Guidance	A/S	Ship S/M and helicopter
Type 61	—	70.25cm	533mm	1765kg	—	—	250kg	Wire Guided	A/Ship	Ship or S/M
UNION OF SOVIET SOCIALIST REPUBLICS										
—	—	—	533mm	—	—	—	—	—	—	Surface ships, submarines and aircraft
—	—	7500cm	406mm	—	—	—	—	—	—	—
UNITED KINGDOM										
Mark 8	—	670cm	533mm	1535kg	45	45km	—	Preset Course Angle & Depth	A/Surface	S/M
—	Tigerfish	646.4cm	533mm	1550kg	Dual high or low	—	—	Wire Guided Acoustic Homing	Primarily A/S	S/M
MW 30 Mark 44	Drill & Practice	256cm	324mm	233kg	—	—	—	Active/Acoustic Homing	A/Surface	Aircraft, ship, helicopter

(continued)

Table 1 (continuation)

No	Name/Note	Length	Diameter	Weight	Speed knots	Range	Explosive charge	Guidance	Target/Role	Carrier
UNITED STATES OF AMERICA										
Mark 14	Mod 5	525cm	533cm	1780kg	32.46	46.9km	230kg	Preset depth & Course Angles	A/Surface	S/M
Mark 37	Mod 3	340cm	484.5mm	649kg	24	—	150kg HE	Free running then Sonar Auto Homing	A/S	S/M
Mark 37	Mod 2	409cm	484.5mm	766kg	24	—	150kg HE	Wire Guidance Active/Passive Sonar Homing	A/S	S/M
NT 37 2C Dimensions and warheads as for Mk 37 Mod 2/3 but speed increased by 40%, range by over 100% and wire guided capability in excess of 13000 yds. Improvements to sonar and homing logic plus additional A/Ship attack modes									A/Surface, A/S	Ship or S/M
Mark 44	Mod 1	260cm	324mm	196.4kg	—	—	—	Active Acoustic	A/S	Ships (Mk 32 or Asroc), aircraft
Mark 45	Mod 1 Astor (Mod 2)	580cm	484.5mm	1003.8kg	—	approx 11km	Nuclear Warhead	Wire Guided	A/S	S/M being replaced by Mk 48
Mark 46	Mod 0, 1 and 2	260cm	324mm	257kg 230kg (1 & 2)	—	—	—	Active/Passive Acoustic Homing	A/S	Ships, (Mk 32 or Asroc), aircraft, helicopter Mod 1 & 2 have liq proplnt
Mark 46	Captor Mod 4	Mk 46 inserted in mine casing and sown in narrow seas. See Jane's Weapon System 2541.441								
Mark 48	Mod 1 & 2	580cm	533mm	1579kg	93km/h	46km	—	Wire Guided and Active/Passive Acoustic Homing	A/Surface, A/S	S/M
—	Freedom Torpedo	572cm	484.5mm	1237kg	40	18.5km	min of 295kg	Wire Guided to hit or free run to intercept followed by pattern run if target missed	A/Surface, A/S	Ship or S/M
DEXTOR (Deep EXperimental TORpedo) Mk 48 replacement ALWT (Advanced LightWeight Torpedo) Mk 46 replacement										

exposed to air of 90% RH at 30°. When heated, it undergoes partial melting near the mp of TNT. The partially liq expl has viscosity values of 4.5 and 2.3 poises at 83° and 95°, respectively, which is approx the viscosity of glycerin at RT

Torpex is considerably more sensitive to impact than Composition B:

Temp, °C	PicArsn Impact Test 2-kg wt, inches
25	15
32	7
104	8

and undergoes partial or complete expln in all trials in the rifle bullet impact test. Its 5-sec expln temp test value (260°) is the same as that of RDX. Cast Torpex is much more sensitive to initiation than is cast TNT, and pressed Torpex is as sensitive as RDX to initiation by MF. Its heats of combustion and expln are 3740 and 1800cal/g, respectively

Sand tests indicate Torpex to be 98 to 99% as brisant as RDX and 122% as brisant as TNT. As judged by plate dent test values, cast Torpex is 120% as brisant as TNT. Fragmentation tests of shell charges indicate it to be 126% as brisant as TNT and, therefore, inferior to Composition B in this respect. The detonation rate of cast Torpex (1" diam charge, $d = 1.81\text{g/cc} = 7495\text{ m/sec}$) is 110% that of TNT. Trauzl Pb block tests and its heat of expln (see above) indicate Torpex to be 162% as powerful as TNT, with the BalPend test showing a superiority of 34%

Torpex is notable for its great blast effect. The following blast comparisons are relative to TNT as 100:

	Air	Air, Confined	Underwater
Peak pressure	122	—	116
Impulse	125	116	127
Energy	146	—	153

Its shaped charge effectiveness (for a 50/36.5/13.5 RDX/TNT/Al formulation) relative to TNT as 100 is:

	Glass Cones	Steel Cones
Hole volume	150	145
Hole depth	127	131

Vacuum stability tests show Torpex to be of the same order of stability as Composition B. Storage at 75° for one month has no effect on its stability,

nor has storage at 65° for 13 months. In the 100° heat test, there is no wt loss in the first 48 hrs, 0.10% wt loss in the second 48 hrs, and it does not expld in 100 hrs. Torpex, therefore, has a high order of stability. However, if all traces of moisture are not removed during manufacture, reaction between this and the ingredients of the compn results in the liberation of gas, which may cause rupture of the ammunition component or increase in the sensitivity of the Torpex to shock (see Torpex 3 at beginning of article)

Preparation. Torpex is manufd by melting TNT in a steam-jacketed kettle equipped with a stirrer and heating the molten TNT to approx 100°. RDX, slightly wet with water, is added slowly and mixing and heating are continued until all water has been driven off. Grained Al is added and the mixt is stirred until uniformity is obtained. The mixt then is cooled, with continued stirring, until its viscosity is such as to render it suitable for loading by pouring. Torpex can also be made by adding the calcd amt of TNT to Composition B to maintain the desired proportion of RDX/TNT, heating and stirring, and adding 18% Al to complete the mixt

Analytical. The composition of Torpex can be detd by extracting a weighed sample with cold benzene or toluene that has been saturated with RDX. The residue is dried and weighed and the loss in weight is calcd to % TNT. The dried residue is extracted with hot acetone, dried, and weighed. The loss in weight is calcd to % RDX. The weight of the final residue is calcd to % Al

Subsequent History. Because of the sensitivity of Torpex, there was developed and used in the USA and Engl a compn designated as **DBX**, which can be loaded by casting and is suitable for depth bomb charges (see Vol 3, D19-L). Representing replacement of half the RDX in Torpex by amm nitrate (AN), DBX is composed of RDX 21, AN 21, TNT 40 and Al 18%. A variation of DBX, designated **Minex** (see Vol 8, M135-L), contains RDX 5 to 15, AN 25 to 35, TNT 40 and Al 20%. When cast, DBX has a d of 1.68g/cc and is gray in color. It is less sensitive than Torpex, as shown by its impact test value of 10", fewer explns in the rifle bullet impact test, and a greater minimum detonating charge of Diazodinitrophenol whether in loose or cast form. Cast DBX has a rate of detonation of 6800m/sec as compared with 7600 for Torpex,

and DBX is less brisant than Torpex, as indicated by relative plate dent test values of 102 and 120, respectively. Because of its better oxygen balance, DBX is more powerful than Torpex, as shown by respective BalPend test values of 146 and 134 as compared with TNT. DBX is very slightly superior to Torpex, with respect to underwater shock, which makes it particularly suitable for use in depth bombs; but its air blast value is slightly less than that of Torpex. Due to the presence of AN, DBX is somewhat hygroscopic and reacts with metals

Another modification of Torpex are compositions designated HBXs (High Blast Explosive). See Vol 7, H23-R to H35R for a complete description of these expls. Since they contain no AN, they do not have the objectionable hygroscopicity of DBX

Refs: 1) Anon, "Military Explosives", **TM 9-1910** (1955), 196-99 2) Anon, *EngrgDesHndbk*, "Explosives Series, Properties of Explosives of Military Interest", **AMCP 706-177** (1971), 359-63 3) J.E. Ablard, "HBX-1: Its History and Properties", **NAVSEA-03-TR-021**, Contract No DAHCO4-72-A-0001, Naval Sea Systems Command, Washington (1975)

Totalit (Swiss). Expl consisting of AN 95.5 and paraffin (mp 54-56°) 4.5%, suitable for military purposes. Following are its properties: detonation equation, $C_{25}H_{52} + 76NH_4NO_3 \rightarrow 25CO_2 + 178H_2O + 76N_2$; volume of gases at NTP, 971.5 l/kg; heat of expln at const vol, w vapor, 1162.8 kcal/kg; temp of expln, 3015°; specific pressure (specific force) (f) 12021 (Refs 1 & 2). Meyer (Ref 3) gives the compn of Totalit as AN with about 6% paraffin

Refs: 1) A. Stettbacher, **NC 10**, 109-10 & 128-30 (1939) 2) *Ibid*, "Pólvoras y Explosivos", G. Gili, Buenos Aires (1952), 136 3) R. Meyer, "Explosives", Verlag Chemie, NY (1977), 355

Touillage or Détolition (Fr). The procedure for extracting residual Tolite (TNT) for di- and tri-spent acids by means of mono-spent acid
Ref: Pepin Lehalleur (1935), 174

Toval. Trade name of ammonia gelatin Dynamite which was distributed in the USA by DuPont. It was DuPont's densest Dynamite, deton vel 4000m/sec at d 1.60g/cc, and was particularly suited for blasting soft to medium hard rock, which requires a high density and water resistant product

Refs: 1) Anon, *Blasters' Hndbk* (1977), 81, 85 & 473 2) R. Meyer, "Explosives", Verlag Chemie, NY (1977), 296

Tovex. A series of slurry blasting agents (water gels) manufd by DuPont. They consist of an AN slurry, sensitized with monomethylamine nitrate (MMAN), and with a thickener and cross-linking chemical to promote water resistance. Tovex provides increased safety (thru low hazard and initiation sensitivity), high water resistance, good fume characteristics, and a low propensity for sympathetic detonation

Table 1 lists the currently available Tovex formulations and some of their characteristics

Tovex 90 is a small diameter item for use in underground mining where a light load is sufficient to break the rock. It is also an adequate primer for ANFO in small diameter holes

Tovex 100 and *200* are designed for use in underground mining and open work in boreholes from 1 to 1½" in diameter. Both products are adequate primers for ANFO in small-diameter holes. *Tovex 100* is considered an excellent replacement for 40% ammonia Dynamites. Its water resistance is superior to standard gelatin and semigelatin Dynamites. *Tovex 200*, with its Al additive, is used in hard-shooting rock where displacement of the "muck pile" is essential to good performance

Tovex 300 permissible water gel is a cart-ridged expl designed for use in underground coal mines

Tovex 500 is a non-cap-sensitive water gel of medium strength used in quarrying and construction

Tovex 650 is a non-cap-sensitive, high strength, high density water gel designed to give the best fragmentation and greatest displacement in most rock formations. It is ideally suited for submarine blasting in water depths up to 200 ft

Tovex 700 is a cap-sensitive, medium density, velocity, and energy water gel designed for use

Table 1 (from Ref 1)
DuPont Water Gels

DuPont Product	Diameter (inches)	Density (g/cc)	Velocity		Water * Resistance	Fume Class	Cap ** Sensitivity	D.O.T. Class
			Ft/sec	M/sec				
TOVEX 90	1-1½	0.90	14,100	4,300	Good	1	Yes	A
TOVEX 100	1-1¾	1.10	14,760	4,500	Excellent	1	Yes	A
TOVEX 200	1-1¾	1.10	15,750	4,800	Excellent	1	Yes	A
TOVEX 300	1-1½	1.02	11,150	3,400***	Good	A	Yes	A
TOVEX 500	1¾-4	1.23	14,100	4,300	Excellent	1	No	A
TOVEX 650	1¾-4	1.35	14,750	4,500	Excellent	1	No	A
TOVEX 700	1¾-4	1.20	15,750	4,800	Excellent	1	Yes	A
TOVEX 800	1¾-4	1.20	15,750	4,800	Excellent	1	Yes	A
TOVEX T-1	1	0.25 lb/ft	22,000	6,700	Good	3	Yes	A
TOVEX P	2-4	1.10	15,750	4,800	Excellent	1	Yes	A
TOVEX S	2¼ & 2½	1.38	15,700	4,800	Excellent	-	Yes	A
							SSS Cap	
TOVEX C	Bag packed	-	-	-	Excellent	1	Yes	A
TOVEX EXTRA	4-8	1.33	18,700	5,700	Excellent	-	No	B
POURVEX EXTRA	3½ plus Poured	1.33	16,000	4,900	Excellent	-	No	B
DRIVEX	1½ plus Pumped	1.25	17,300	5,300	Excellent	1	No	A

*Water resistance will vary with waterhead

**Cap sensitivity will vary with temperature

***Unconfined. All others confined

in quarries and construction

Tovex 800 is a cap-sensitive, high energy, medium density and velocity water gel designed for the most difficult blasting conditions

Tovex T-1 is a small diameter, long tubular water gel product used for preshearing in construction and mining. It is made in one size only and is produced in coils 50 ft long for easy use as unit charges in the boreholes

Tovex P is a cap-sensitive, high energy cartridge water gel designed for priming ANFO

Tovex S is a cartridge water gel designed specifically for seismograph land exploration. It is packaged in threaded plastic shells that may be quickly assembled into rigid, highly water resistant charges

Tovex C is designed for chute blasting or secondary blasting. It is packed in a moldable package and conforms well to the shape of the rock to be blasted

Tovex Extra is a high density, high velocity, water resistant water gel designed for blasting in very difficult conditions. It is non-cap-sensitive,

requiring a high energy primer such as an HDP-1. It is frequently used as a booster primer in large diameter ANFO columns

Pourvex Extra is a non-cap-sensitive, Class B water gel that can be either poured or pumped into boreholes of 3½" or larger in diameter. It performs particularly well where the rock or ore is massive and has a high sonic velocity

Drivex is a Class A water gel that can be pumped by modified diaphragm pumps into vertical or downward-sloping boreholes as small as 1½" in diameter. The complete expl-to-rock coupling and high density characteristics are responsible for this products' excellent shooting performance, particularly in shaft and underground work with small diameter holes

See also under "Slurry Explosives" in this Vol Refs: 1) Anon, *Blasters' Hndbk* (1977), 13-15, 67-78 2) C.E. Gregory, "Explosives for Australasian Engineers", 3rd Ed, Univ of Queensland Press (1977), 28, 34, 70 & 76 3) E.E. Hannum, Ed, *Expls&Pyrots* 11 (2), (Feb 1978)

Tovite. DuPont powdered ANFO blasting agent available in round, plastic-lined spiral tubes or textile bags. Its packaged d is 1.12g/cc; theoretical energy, 875cal/g; and its vel of deton varies with diameter from about 3660m/sec in 4" diameters to 4570m/sec. Its water resistance depends on the integrity of the package. Tovite is used as column load in boreholes filled with water, thickened with mud or drill cuttings, replacing lower d products that sink at an unacceptably slow rate

Refs: 1) Anon, *Blasters' Hndbk* (1977), 66
2) R. Meyer, "Explosives", Verlag Chemie, NY (1977), 296

TOW. US heavy anti-tank weapon system in production and service. The acronym is derived from its description as a Tube-launched Optical-ly-tracked Wire-guided anti-tank weapon system. Design work started in 1962, the first firings were carried out in 1968 and the weapon system entered service in 1972

The TOW weapon system (M151E2) consists of six major units: tripod, traversing unit, launch tube, optical sight, missile guidance set and battery assembly, housed in the missile guidance set. The missile itself (BGM 71A) is never handled by the launch crew, all electrical and mechanical connections being made automatically when its container is inserted in the launch tube. The solid propellant motor burns initially only long enough to propel TOW from the launcher. To ensure safety for the operator, the missile then coasts for about 12m. The missile wings and control tail surfaces are extended from the missile body. An IR source on the missile starts to operate and two command-link wires are dispensed from internal spools. The first stage of arming the warhead occurs. The solid propellant flight motor is activated at the end of the 12m coasting period and the HEAT warhead is fully armed. The missile has then travelled about 60m

The gunner operates the traversing unit and keeps the cross-hairs of the optical sight on the target. The IR sensor tracks the signal from the modulated lamp in the missile and detects any deviations from the line of sight path to the target. It provides continuous information over the wire link to the missile guidance set which produces

signals which are delivered with those from a gyroscope, to the control surfaces to correct the flight path and bring the missile back to the line of sight

The missile has a length of 1285mm, width 221mm, height 221mm, and wt of 24.5kg. Its velocity is 200m/sec, with a range of 65 to 3750m

Refs: 1) R.T. Pretty, Ed, "Janes's Weapon Systems-1977", Franklin Watts, NY (1966), 45 & 159 2) M.J.H. Taylor & J.W.R. Taylor, "Missiles of the World", Charles Scribner's Sons, NY (1976), 152-53 3) D.H.R. Archer, Ed, "Jane's Infantry Weapons-1978", Franklin Watts, NY (1978), 630

TOXICOLOGY OF EXPLOSIVES AND PROPELLANTS

Introduction

Beyond the dangers of untimely detonation, most expls and proplnts (*E&P*), like other chemicals, pose the dangers of toxicity at some exposure level. Observations of the toxic effects of *E&P* on human beings have been largely the result of occupational exposures to high levels of these substances during WWs I and II; for these were periods of high munitions production rates and insufficient emphasis on industrial hygiene. Concern over the possible long-term hazards to the general population and to the environment of much lower levels of *E&P* and associated waste products was given impetus by the Federal Water Pollution Control Act of 1972 (Ref 40). The Act made it necessary to develop and evaluate a scientific data base from which to determine the environmental hazards associated with *E&P*. Responsibility for most of these efforts devolved on the US Army Medical R&D Command; to this end, the Command has sponsored a considerable amount of research, which has been conducted by the US Army Medical Bioengineering R&D Laboratory (USAMBRDL). That research constitutes the main body of modern *E&P* toxicology

Scope. The three major military expls (TNT, RDX and HMX), the four most important military proplnt materials (Nitrocellulose, Nitroglycerin, Nitroguanidine and Dinitrotoluene) and two volatile and expl by-products (Tetranitromethane from TNT manufg and Methyl nitrate from RDX/HMX manufg) are discussed here. In addition to references on these topics, a separate reference section is devoted to other *E&P* materials. Information related to human health effects is emphasized in this article. Included are the mostly qualitative accounts, by industrial or military physicians, of human intoxication; documentation of mammalian toxicity expts; and the results of microbial mutagenicity testing, a comparatively recent development. Brief summaries have been presented of the results of tests on aquatic organisms; because of their sensitivity to the pollutants that surround them, such organisms provide responses indicative of water quality

Sources of Information. The toxic properties of the major *E&P* were reviewed in several technical reports of the early 1970's: TNT (Refs 14 & 33), RDX/HMX (Ref 12), NC (Ref 14), NG (Ref 14), Tetranitromethane (Ref 18) and Methyl nitrate (Ref 18). Recent exptl studies cited below provide important additional data, especially on the chronic effects on laboratory animals

TNT (2,4,6-Trinitrotoluene)

Human Health Effects (Refs 3, 14 & 33). TNT exposures can occur by inhalation of the dust, thru ingestion, and via skin absorption. Among the first signs of TNT intoxication are changes in the blood: the red blood cell count and hemoglobin content decrease; abnormal red cells are seen; and there is a transitory increase in leukocytes and lymphocytes. Rashes and skin eruption may be associated with these effects. Increased capillary fragility leads to nose bleeds and hemorrhages of the skin and mucosa. At sufficiently high and prolonged exposures, more serious blood phenomena appear. These include methemoglobinemia, with consequent cyanosis; hyperplasia of the bone marrow leading to aplastic anemia (because the marrow no longer produces blood cells); and a drastic loss of blood platelets. Petechiae often occur in conjunction with aplastic anemia

A second type of symptom, toxic jaundice, indicates toxic hepatitis; this ultimately leads to yellow atrophy of the liver

Death can occur from either anemia or (especially in younger people), toxic hepatitis. During WWI, 24000 cases of TNT poisoning were reported, of which 580 people died over the period 1914-1918. Better hygiene decreased the latter number to only 22 fatalities during WWII

Effects of TNT on the kidney are manifest in increased filtration rates. In mild cases of TNT intoxication, urgency, frequent urination and lumbar pain may be the only symptoms

Individuals exposed to TNT may complain of a constant bitter taste, excessive salivation, nausea, vomiting and gastritis. The latter is due to reduced secretion of pancreatic enzymes

According to European accounts, chronic work-place exposure to TNT was associated with cataracts of the eyes. There have been various

reports of central nervous system intoxication (neurasthenia, polyneuritis). No carcinogenic effects of TNT on human beings have been reported

Inhalation of 0.3 to 1.3mg/m³ of TNT in a munitions plant for 8 hrs/day, 5 or 6 days a week, for an average of 33 days, was sufficient exposure to produce blood changes and rashes in a large proportion of a group of human volunteers. A bitter taste was noticed by subjects who absorbed 7.1mg/kg of TNT thru the skin during a single 8-hour exposure

The maximum permissible inhalation level in the USSR is 1.0mg/m³. The OSHA TLV is 1.5mg/m³ (Ref 13). The US Army has a standard of 0.5mg/m³ (Ref 25)

Mammalian Toxicology (Refs 14, 19, 33, 34 & 46). Studies to determine the acute LD50 of TNT in any species were not conducted until 1975. The acute oral LD50 for male rats was determined by one group to be 1010mg/kg and for females, 820mg/kg; LD50 values for mice were 1014mg/kg for males, 1009mg/kg for females. Early investigators concluded that cats and dogs are somewhat more sensitive to TNT

and that rabbits, rats and guinea pigs are somewhat less. The various effects observable in man, with the exception of cataracts, were found in at least some of these species in acute and chronic studies. There were striking differences in individual susceptibilities. Ninety day ("subacute" or, preferably "subchronic") oral toxicity studies in rats, mice and dogs showed depressed body weight, reduced food consumption, mild to moderate hemolytic anemia, enlarged spleens and (usually) livers, hemosiderosis of the spleen and colored urine. Chronic studies in rats, mice and guinea pigs showed no evidence of carcinogenicity. Moderate sensitization to TNT was induced in guinea pigs

Metabolism, Mutagenicity and Carcinogenicity (Refs 14, 33, 34, 39, 46 & 48). A number of metabolites of TNT were reported in the literature prior to 1974. These were apparently formed by the reduction of nitro groups or by oxidation of the methyl group, and possibly by condensation of hydroxylamine groups produced by reduction (Table 1). Moreover, an unidentified glucuronide was claimed as a major metabolite and was presumed to involve the

Table 1
Reported TNT Metabolites (from Ref 14)

Metabolites	Isolates from Sources Treated with TNT					
	Human	Rabbit	Rat	Reaction with Xanthine/ Xanthine Oxidase	Pig Liver Extract	Bacteria
1. Aminodinitrotoluene						
a. Unspecified isomer	X	—	—	—	—	—
b. 4-Amino isomer	X	X	X	—	X	X
c. 6-Amino isomer	X	X	—	—	—	X
2. 4-Hydroxylamino- 2,6-dinitrotoluene	—	X	—	X	—	—
3. Tetranitroazoxytoluene						
a. Unspecified isomer	X	—	—	—	—	—
b. p,p'-Isomer	—	X ^a	—	—	—	—
4. 1,3-Diamino-5-nitrobenzene ^b	—	—	X	—	—	—
5. Trinitrobenzyl alcohol ^c	—	X	X	—	—	—

a—Formed in standing urine, believed to be an artifact resulting from condensation of Metabolite 2

b—Presumed to be formed when TNT is oxidized to the carboxylic acid, decarboxylated, then reduced.

c—Postulated because red pigment found in urine can be produced only from this intermediate

intermediate metabolites 2,4,6-trinitrobenzyl alcohol or an aminodinitrobenzyl alcohol. A recent investigation has essentially confirmed and augmented the previous findings. Investigators examined the urine of rats, mice, rabbits and dogs exposed to TNT by three routes. They identified oxidation and reduction products of TNT with varying degrees of certainty and demonstrated the presence of glucuronide conjugates, as well as unidentified polar materials. In addition to the compds in Table 1, they obtained evidence for 2-hydroxylamino-4,6-dinitrotoluene, 2,4-diamino-6-nitrotoluene, 2,6-diamino-4-nitrotoluene, 2,4,6-trinitrobenzoic acid and (with considerable lack of confidence) 2,4,6-trinitrobenzyl alcohol. They confirmed that 2,2',6,6'-tetranitro-4,4'-azoxytoluene is not a constituent of fresh urine, but may form from 4-hydroxylamino-2,6-dinitrotoluene when the urine is allowed to stand or during isolation procedures. They saw almost no unmetabolized TNT in urine. The urine of orally dosed rats and mice had a bright red color, but not that of dogs and rabbits. The radioactivity of labeled TNT was mainly excreted, but some ended up distributed in various organs

As regards mutagenic effects, TNT was observed to cause chromosomal changes in the tibial bone marrow cells of chronically exposed Wistar rats, which could indicate potential effects on future generations. TNT was also found to be a frame-shift mutagen in three strains of a bacterium, *Salmonella typhimurium*, with and without metabolic activation; the major microbial metabolites of TNT were not mutagenic. In view of the high correlation generally found between mutagenicity and carcinogenicity, definitive chronic investigations of the carcinogenicity of TNT in animals have been initiated. Isomers of TNT, in the Ames test, appear to be more potent mutagens than TNT itself (Ref 45). Nevertheless, it must be emphasized that TNT has not been directly related to cancer, thus far, in any animal species

Effects on Aquatic Organisms (Refs 14, 41 & 47). There are a number of reports on the toxicity of TNT to fishes. They are mostly concerned with establishment of an LC50 under a variety of exptl conditions. The most acceptable acute tests are 96-hr flow-thru aquatic toxicity tests in which the exposure concns of

test compds have been established by chemical analysis. Few reports, even from the late 1970's, have met all these criteria. Additional test variables, such as species sensitivity, temp and water hardness may be important. Among tests conducted on TNT before 1974, the lowest LC50's were 1.5–2.0mg/l, with conditions not completely defined. Recent acute static toxicity tests on fish include results with the most sensitive fish species, rainbow trout, *Salmo gairdnerii* (96-hr LC50 = 0.8mg/l), which essentially confirm earlier findings

Toxicological Characteristics of Components of TNT "Condensate Wastewaters" (Refs 41, 45 & 47). "Red water" is the aqueous waste formed when TNT is extracted with aq Na bisulfite to remove unwanted TNT isomers (see article on TNT in this Vol). This deeply-colored soln is concd by distillation prior to incineration or to processing for recovery of sulfate values. Condensate from the distillation, which is currently discharged into the aquatic environment, contains a large number of organic compds, among which 2,4-Dinitrotoluene (a carcinogen in animals) is the major component (see below). The condensate compds in Table 2 underwent individual tests for mutagenicity and for acute toxicity to two aquatic organisms. They were also formulated into a mixt in concns shown in column 2 of Table 2. Each concn was set equal to the 90th percentile concn of the substance in the 79 analyses in order to provide adequate representation of minor constituents. Preliminary results indicate that the mixt was more toxic to fathead minnows and water fleas than could be explained by the weighted sum of the toxicities of the constituents. Although 2,4-Dinitrotoluene (2,4-DNT) was the component present in highest concn, its calculated contribution (toxic factor) to the acute toxicity of the mixt to fathead minnows was less than the contributions of 2,3,6-Trinitrotoluene or 1,3-Dinitrobenzene. In tests on water fleas, however, 2,4-DNT had the highest toxic factor of all the constituents (now shown in Table 2). In the main, the acute and subacute mammalian toxicity of condensate water is slightly greater than, but essentially similar to, that of 2,4- and 2,6-DNT. Most of the compds in Table 2 were mutagenically positive in the metabolically activated Ames test for mutagenicity. This has been cause

Table 2
 "Synthetic" Condensate Wastewater Mixture (from Ref 47)

Compound	Concentration mg/liter ^a	Relative Concentration %	Ames Mutagenicity ^b	Toxic Units to Fathead Minnows ^c
Toluene	0.200	0.590	—	0.016
2-Nitrotoluene	0.030	0.089	—	0.0007
4-Nitrotoluene	0.100	0.295	+	0.002
2,3-Dinitrotoluene	0.400	1.180	+	0.211
2,4-Dinitrotoluene	14.700	43.377	+	0.452
2,5-Dinitrotoluene	0.400	1.180	+	0.308
2,6-Dinitrotoluene	7.300	21.541	+	0.369
3,4-Dinitrotoluene	0.500	1.457	+	0.333
3,5-Dinitrotoluene	0.520	1.534	+	0.024
2,3,6-Trinitrotoluene	0.268	0.791	+	2.233
2,4,6-Trinitrotoluene	0.400	1.180	+	0.167
2-Amino-4-nitrotoluene	0.033	0.091	+	0.0004
2-Amino-6-nitrotoluene	0.010	0.030	+	0.0002
3-Amino-4-nitrotoluene	0.027	0.080	+	0.001
2-Amino-4,6-dinitrotoluene	0.020	0.059	+	0.001
2-Amino-3,6-dinitrotoluene	0.030	0.089	+	0.038
3-Amino-2,4-dinitrotoluene	1.500	4.426	+	0.123
3-Amino-2,6-dinitrotoluene	1.200	3.541	+	0.106
4-Amino-2,6-dinitrotoluene	0.600	1.770	+	0.087
4-Amino-3,5-dinitrotoluene	0.200	0.590	+	0.015
5-Amino-2,4-dinitrotoluene	0.700	2.066	+	0.292
1,3,5-Trinitrobenzene	0.153	0.451	+	0.149
1,3-Dinitrobenzene	4.000	11.803	+	0.541
1,5-Dimethyl-2,4-dinitrobenzene	0.390	1.151	+	0.049
3,5-Dinitroaniline	0.058	0.171	+	0.003
3-Methyl-2-nitrophenol	0.012	0.035	—	0.0002
5-Methyl-2-nitrophenol	0.032	0.094	—	0.0006
2,4-Dinitro-5-methylphenol	0.085	0.251	+	0.027
3-Nitrobenzotrile	0.013	0.035	+	0.0002
4-Nitrobenzotrile	0.009	0.027	+	0.0003

a—These are 90th percentile concns based on 79 condensate water analyses

b—Observation of mutagenicity indicated by +; failure to observe mutagenicity by —

c—Toxic Unit = Concentration in mixture/96-hr LC50

for concern, since mutagenicity is a good — though not infallible — indicator of carcinogenicity

Toxicity of "Pink Water" (Refs 20, 34 & 41).
 Exposure to sunlight or artificial ultraviolet radiation converts TNT in aq soln to a variety of photodecompn products (see article on TNT in this Vol). The colored photodegraded mixt, known as "pink water", has a lower acute

mammalian toxicity than does the soln of the parent compd; the mouse oral LD50 value of 100% degraded TNT is about four times that of the original material (ie, degraded TNT is 1/4 as toxic as the parent material). Toxicity to aquatic organisms also decreases in this process. For instance, the 96-hr static aquatic LC50 of 100% photodegraded TNT to rainbow trout is 13.3 mg/l, compared to the above-cited value of

0.8mg/l for unphotolyzed TNT. Frequently TNT and RDX occur together in LAP (load assembly and pack plants) wastewaters. There is no evidence of synergism between TNT and RDX in the results of tests of LAP wastewaters on either fish or mammals. As with water containing only TNT, toxicity both to aquatic animals and to mammals was diminished appreciably thru the degradative effect of ultraviolet light (or, in some cases, natural sunlight) on mixts of TNT and RDX. TNT dominates the mammalian toxicity of LAP wastewaters, of which it is the principal constituent

Toxicity of Impurities of TNT. Of the three classes of impurities of TNT, only the Dinitrotoluenes (DNT's), and especially 2,4-DNT, have been studied in any detail (see below). What little is known of the toxicity of a second group of impurities, TNT isomers, has been found as the result of research on "condensate wastewaters" (see above). Just as Dinitrotoluenes in which the nitro groups are *ortho* or *para* to each other are considerably more toxic to aquatic life than those where these groups are *meta* to each other, so 2,3,6-Trinitrotoluene is 20 times as acutely toxic as TNT to fathead minnows (Ref 47); in the 2,3,6-isomer, the first and third nitro groups are *ortho* and *para* respectively, to the second nitro group, while in TNT the nitro groups are all *meta* to one another. Thus, it is likely that the other isomers of TNT are also significantly more toxic to fathead minnows. Except for Tetranitromethane (see below) and certain compds listed in Table 2, there is no information on the third group, oxidation products of TNT that occur as impurities

RDX (Hexahydro-1,3,5-trinitro-1,3,5-triazine)

Human Health Effects (Refs 4 thru 12, 21 & 27). Munitions workers have experienced acute RDX intoxication, mainly from inhaling the fine particles; ingestion may have been a contributing factor. Troops have occasionally suffered symptoms of RDX intoxication following consumption of Composition C-4, a plastic expl containing 91% RDX; Composition C-4 was chewed by soldiers to produce the "high" of ethyl alcohol, or it was used as a fuel for cooking. In the latter case, the victims may have inhaled the fumes or inadvertently introduced RDX into their food. Acute effects were seen

within a few hours of exposure, ie, after a latent period. The course of acute RDX poisoning appears to follow a general sequence, though some symptoms may be missing in any individual case: restlessness and hyperirritability; headache; weakness; dizziness; severe nausea and vomiting; aggravated and prolonged epileptiform seizures (generalized convulsions), which are often repeated; unconsciousness between or after convulsions; muscle twitching and soreness; stupor, delirium, disorientation and confusion; then gradual recovery, accompanied in the beginning by amnesia. In a few cases, workers have suffered irritation to the skin, mucous membranes and conjunctivae by fine particles of RDX

The clinical findings in RDX intoxication may include fever; rapid pulse; hematuria due to effects on the proximal tubules of the kidney; proteinuria; azotemia; occasional mild anemia; neutrophilic leukocytosis; elevated SGOT, which may explain the muscle soreness; nitrites in the gastric juices; and electroencephalographic abnormalities. There appears to be no liver involvement; and cerebrospinal fluid is normal

Patients evidently recover completely from the effects of RDX poisoning, the length of time depending on the extent of exposure. The period of recovery varies from a few days to about three months

Thus, RDX intoxication involves gastrointestinal, central nervous system and renal effects. The potential routes of exposure are inhalation of fine particles or fumes, or ingestion; because RDX is a high-melting solid and not very lipid soluble, skin absorption is very unlikely. Although the symptoms may be severe, deaths have apparently been quite few, and no permanent damage seems to have resulted among survivors

Mammalian Toxicology (Refs 12, 15, 17, 21, 23 & 27). As in man, central nervous system excitation is the most prominent acute effect of RDX on most animals. Acute oral LD50's have been reported to range from a high of 500mg/kg in mice to 200mg/kg in rats to less than 100 mg/kg in cats. But LD50's in rats by other routes were much lower: 18mg/kg intravenously and 10mg/kg intraperitoneally. Like humans, and unlike rats, miniature swine showed a 12-24-hr latent period before onset of convulsions. Subchronic doses gave a picture different from that of acute doses. In beagle dogs, daily oral

doses of 10mg/kg for 90 days resulted only in emesis. Daily oral administration of 20mg/kg to rats for 90 days led to lethargy, weight loss, rough hair coat, and eventually death in 8 out of 20 animals but to no neurological symptoms; necropsy showed lung damage

Yet, in another study, fed 40mg/kg for 90 days, mice showed no adverse effects; while the only effect on rats (significant in males) was retarded weight gain. Daily feeding of 10mg/kg to rats for two years showed no toxic symptoms except for retarded weight gain in females. Because of technical problems and because the dose level was too low, the study was not considered definitive for Army purposes. This dose, 10mg/kg, caused severe neurological toxicity and emesis in rhesus monkeys, where 1.0mg/kg daily was a no-effect level over the two-year period

Metabolism, Mutagenicity and Carcinogenicity (Refs 21, 23, 27, 28 & 32). RDX appears to be metabolized, mainly in the liver, to small fragments, such as carbonate (partly exhaled as CO₂), formate and formaldehyde, with very little accumulation in tissues or organs. Mutagenic screening of RDX has produced negative results. These observations, along with the failure of investigators to find tumors in the above-mentioned chronic rat toxicity study at 10mg/kg/day, provide strong indication that RDX is not carcinogenic. However, such a conclusion should be supported by chronic toxicity tests in a second mammalian species at higher doses

Effects on Aquatic Organisms (Refs 31 & 44). An LD50 of 3.6mg/l was found in 96-hr static bioassay tests of RDX on bluegill sunfish (*Lepomis macrochirus*) at pH 6 and 35mg/l water hardness, and represents the lowest LC50 found for any aquatic species. The chronic and acute levels are very close in aquatic organisms. Thus, the lowest observable chronic effect, decreased length of fathead minnow (*Pimphales promelas*) fry, occurred at 3.0mg/l of RDX; this effect was not seen at 1.2mg/l. RDX shows extremely little bioconcn

HMX (Hexahydro-1,3,5,7-tetranitro-1,3,5,7-tetrazocene)

The low solubility of HMX has caused exptl difficulties that have cast in doubt the validity

of all toxicological research done on this compd to date. It would appear that, weight-for-weight, HMX is somewhat less toxic than RDX, but exhibits similar effects. Expts are in progress to confirm or contradict this opinion

Nitrocellulose (NC) (Refs 24, 29 & 42)

NC is a water-insoluble fibrous polymer. Consequently it is not absorbed thru the intestinal wall or cell membranes. This accounts for its total lack of oral toxicity to mammals. Subchronic and chronic feeding to rats and dogs at contents as high as 10% and to mice at 3% of the solid diet resulted in no effects other than those of fiber bulk, ie, as if they had been fed cotton linters.

Suspended NC in concns as high as 1000mg/l showed no effect on four species of fish and four invertebrates in various acute toxicity tests

Nitroglycerin (Glyceryl Trinitrate, NG or TNG)

Human Health Effects (Ref 14). NG has been used as a vasodilator drug in medicine, especially for the treatment of angina; thus, there is a fairly extensive literature on its biochemical and clinical aspects. The most common medicinal dose is 0.65mg (roughly 0.01mg/kg), but many patients safely receive 20 times this (about 0.2mg/kg) daily. Survival has been noted after quantities up to 400mg (about 6mg/kg) were administered orally or sublingually. Two of the more noticeable symptoms are headache and falling blood pressure

Chronic human exposure to NG is characterized by methemoglobinemia and the development of tolerance to the drug. Withdrawal from frequent exposure to NG causes severe headaches, "Monday head", among munitions workers

Skin absorption is the most likely route of exposure for NG since it is not very volatile. A TLV of 0.2ppm, or 2mg/m³, in air was adopted by the American Conference of Government Industrial Hygienists in 1972, to encompass cutaneous exposure — including mucous membranes and the eye — as well as inhalation. But a reduction in this value may be desirable in view of withdrawal headaches suffered by volunteers after exposure to such a level

Mammalian Toxicology (Refs 14, 19 & 38). The lethal dose of NG appears to vary according to the route of administration. Thus, an early

report gave the LD50 in mice as 30mg/kg by the subcutaneous route and 205mg/kg intraperitoneally. More recently, the following acute oral LD50's were obtained: 822mg/kg in male rats, 884mg/kg in the females; 1188mg/kg in male mice, 1055mg/kg in the females

After intravenous injection of a fatal dose of NG in rabbits, immediate respiratory stimulation was observed, closely followed by slowing of the heartbeat, muscular twitchings and convulsions. Between convulsions, the heart rate was accelerated and the respiratory rate decreased; the animals died of respiratory paralysis. The toxicological picture of NG poisoning is similar to that of asphyxiation, due either to the fall in blood pressure or methemoglobinemia. Despite similarities to Na nitrite poisoning, the toxic effects of NG cannot be explained solely on the basis of its nitrite action

In comparison to the relatively high lethal dose of NG (eg, about 200mg/kg in the cat), repeated small subcutaneous doses may cause toxic effects. Following 10 daily subcutaneous injections of 15mg/kg, cats showed albumin and bile pigments in the urine; icterus and hemorrhages in the dura, cerebellum, liver and spleen; and pigment deposits in the latter two organs. In other studies of cats, inhalation or cutaneous treatment with NG resulted in rapid formation of methemoglobin and of Heinz bodies on red blood cells. With rather low level daily subcutaneous injections (0.1mg/kg) for 40 days, one particular cat suffered anemia and fatty degeneration of the liver, followed by death; yet 50 daily doses of 7.5 or 15mg/kg was survived by the majority of a group of cats. Air saturated with NG (0.6ppm) produced only anemia and moderate leukocytosis in 68 days; inhalation for 156 days produced tolerance in cats

The chronic effects of NG are species-dependent. Daily doses of 1, 5 or 25mg/kg in dogs for 12 months produced only a little, dose-related transient methemoglobinemia. Mice dosed at 115 or 96mg/kg/day (male or female) showed no toxic effects over 24 months. At very high doses, 1020 or 1060mg/kg/day (male or female), toxic anemia was the most important symptom. In studies of up to two years in rats, low doses (3.04 or 3.99mg/kg/day in males or females) had no apparent toxic effects. Middle doses (31.5 or 38.1mg/kg/day in males or females) showed

lesions that could develop into hepatocarcinomas. At high doses (363 or 434mg/kg/day in males or females), methemoglobinemia, cholangiofibrosis, hepatocellular carcinoma and interstitial cell tumors of the testes were the most prominent effects. Thus, NG was shown decisively to be a carcinogen in rats

Metabolism and Mutagenicity (Refs 14, 19, 30 & 39). NG undergoes stepwise deesterification by mammals (as well as by bacteria, Ref 37) to the two isomeric glyceryl dinitrates, thence to the two isomeric glyceryl mononitrates, and finally to glycerol; these and the dinitrate and mononitrate glucuronides and unknown polar compds are excreted in the urine. Glycerol is metabolized to carbon dioxide. Human beings fed NG excrete a small portion of it in the urine as the mononitrate ester. NG has been characterized as a weak mutagen; surprisingly, glycerol 1,2-dinitrate is a much stronger mutagen

Effects on Aquatic Organisms (Ref 43). NG is toxic to aquatic biota. The most sensitive fish species, the bluegill sunfish, *Lepomis macrochirus*, exhibited a minimum 96-hr LC50 of 1.38mg/l at 20°C (ie, acute toxicity). Bioconcn was shown to be an unimportant factor. A chronic no-effect level was found at 0.03mg/l (most sensitive species, fathead minnow)

Nitroguanidine (Ref 16)

The reported oral LD50 for Nitroguanidine in male albino rats, 4640mg/kg, indicates exceptionally low toxicity. No gross evidence of toxicity — such as effects on food intake, weight gain or survival — were observed when these animals received a 1% dietary level of Nitroguanidine for 30 days, equivalent to a mean daily dosage of 930mg/kg. Nitroguanidine's high water solubility, 4.4g/l at 25°C and 90g/l at 100°C, suggests a low distribution coefficient. The foregoing facts indicate that Nitroguanidine has a low propensity to bioconcentrate

DNT(Dinitrotoluene)

In the munitions industry, DNT is of concern both as an impurity in TNT, as a constituent of TNT "condensate wastewaters" (see above), and as a coating for proplnts. It consists principally of 2,4-DNT (ie, 2,4-Dinitrotoluene) with a considerable admixt of 2,6-DNT and lesser proportions of the 2,3-, 2,5-, 3,4- and

3,5-isomers. The isomer ratios are somewhat variable. Recent toxicological investigations have concentrated on 2,4-DNT and to a lesser extent on 2,6-DNT

Human Health Effects (Refs 1, 2 & 14). DNT is likely to be absorbed thru the skin, since it is fat-soluble and is a low-melting solid or a liq, depending on the temp and the proportions of the isomers; its vapors may be inhaled, or it may be ingested by handlers who have failed to wash their hands well before eating. The most common early symptom of DNT poisoning is an unpleasant metallic or slightly bitter taste. Other symptoms may include muscular weakness, fatigue, headaches, loss of appetite, giddiness, dizziness or drunkenness, nausea, vomiting, labored breathing, palpitation of the heart, difficulty in sleeping, pain (especially in the knees), numbness or tingling in the extremities, tremors, nystagmus, and sluggish reflexes. There were two cases of acute toxic hepatitis, with jaundice, among one group of 154 exposed workers. The chief clinical findings are pallor, cyanosis, and normocytic-normochromic anemia. Patients appear to recover completely from DNT poisoning

Mammalian Toxicology of DNT's (Refs 1, 14, 19, 22, 35, 36, 39 & 46). Early quantitative results concerning the toxicity of DNT in animals were somewhat contradictory and virtually worthless as a predictive tool. Recent work has been making up for this deficiency. The acute oral LD50 values for 2,4-DNT in male and female rats were determined as 568 and 650mg/kg, respectively; corresponding values for mice were 1954 and 1340mg/kg. Treated animals became cyanotic and ataxic after dosing. Animals that did not die in 24 hours recovered completely. The acute toxicities of DNT isomers lie between 1/3 and three times that of 2,4-DNT in rats and mice. The 3,5-isomer is the most toxic

2,4-DNT and 2,6-DNT are very mild primary irritants to rabbit skin and cause no primary eye irritation in this species. The other DNT isomers are mild or moderate skin irritants to rabbits. 2,6-DNT produces mild dermal sensitization in guinea pigs while 2,4-DNT produces none

Subchronic toxicity tests (90 days) of several species showed dogs to be the most sensitive mammals to 2,4- and 2,6-DNT; 5mg/kg/day and 4mg/kg/day were no-effect levels for the two

compds, respectively; 25mg/kg/day and 20 mg/kg/day of the two compds, respectively, were toxic to all of the dogs and lethal to some. Rats showed slight toxicity from 2,4-DNT at 34–38mg/kg/day. Mice were especially resistant to 2,4-DNT, with no adverse effects at 137–147 mg/kg daily; this is attributable to the low percentage of 2,4-DNT absorbed (see below). In the case of 2,6-DNT, rats and mice responded to similar subchronic dose levels in the same way and were less sensitive than dogs. With both compds, all species showed decreased spermatogenesis along with methemoglobinemia and related effects; dogs, in particular, had the neuromuscular symptoms of incoordination and rigid paralysis

Chronic (24-month) effects of 2,4-DNT were studied in dogs (toxic to some at 1.5mg/kg/day), rats (toxic to some at 3.9–5.1mg/kg/day), and mice (slightly toxic to some at 13.5mg/kg/day). The effects included those seen earlier in the subchronic studies, namely methemoglobinemia, aspermatogenesis, and central nervous system effects; in addition, however, liver degeneration and carcinomas — especially in rats, kidney changes including tumors, subcutaneous and mammary gland tumors, and abnormal pigmentation were observed. Life spans were reduced. The evidence clearly shows that 2,4-DNT is a carcinogen in mammals

Metabolism, Accumulation and Mutagenicity of 2,4-DNT (Refs 19, 35, 36 & 39). Mice absorb only 8–12% of an oral dose of 2,4-DNT, but they evidently absorb a much higher proportion of 2,6-DNT; rats, rabbits, dogs and monkeys absorb 75–85% of 2,4-DNT. Metabolism of 2,4-DNT, and evidently of the other isomers, appears to involve one or more of the following: reduction of one or both nitro groups, oxidation of methyl to hydroxymethyl or carboxyl, and conjugation (probably as sulfates or glucouronides). Products, but virtually no parent DNT, are excreted in the urine. The radioactivity of labeled DNT's is distributed and retained, to a degree, in various tissues, in particular liver and kidney. Multiple dosing of 2,4-DNT increases the amount of tissue radioactivity as compared to a single dose; this suggests relatively long-term accumulation. In the Ames test, all DNT isomers are mutagenic in two strains of *Salmonella typhimurium* with or without metabolic activation. In view of these

Table 3
Acute Toxicity^a of DNT Isomers to
Two Aquatic Species (from Ref 47)

DNT Isomer	Fathead Minnows (96-hr LC50, mg/L)	Water Fleas (48-hr EC50, mg/L)
2,4-DNT	32.5	35.0
2,6-DNT	19.8	21.7
3,5-DNT	22.0	45.1
2,3-DNT	1.9	4.7
2,5-DNT	1.3	3.4
3,4-DNT	1.5	3.1

a—Static aquatic toxicity tests at 20°C

findings, it is not surprising that cancers were found in all three species subjected to chronic toxicity testing with 2,4-DNT

Effects of the Individual DNT Isomers on Aquatic Organisms (Ref 47). The acute toxicity of all six DNT isomers has been tested in two aquatic species commonly used as exptl models, fathead minnows (*Pimphelus promelas*) and water fleas (*Daphnia magna*). As demonstrated in Table 3, the isomers form two distinct toxicity groups: those with the nitro groups *ortho* or *para* to each other are about an order of magnitude more toxic than those in which the nitro groups are *meta* to each other. This suggests that the electrophilic character of a nitro group or its ease of reduction may be related to the toxicity

Tetranitromethane (TNM) (Refs 18, 26 & 39)

TNM, bp 125°C, is a volatile by-product of the manuf of TNT. It has a sufficiently high vapor pressure at room temp, 8.4 torr at 20°C (11000ppm or 90000mg/m³), to present a decided inhalation hazard

Six-hour exposures of cats to 0.1–0.4ppm of TNM caused eye irritation. Cats exposed to levels above 3 ppm for varying periods of time (20 mins to several hours) died or showed severe pulmonary irritation. All of a group of 20 rats died after breathing 33ppm of TNM for 10 hours. Eleven out of 19 rats exposed for six months to 6.35ppm of TNM died, whereas two dogs exposed in the same manner developed only mild symptoms. In mice, the 2-hr LC50 was determined as 75ppm. The cause of death in exptl animals

appeared to be respiratory tract irritation and pulmonary edema, but not methemoglobinemia, with death due to severe pneumonia. One-hr exposure to 0.4ppm produced effects on conditioned reflex activity in rats

Recent subchronic studies involved continuous exposure of rats to TNM over a period of 14 days. At 7.5ppm, 65–75% of the animals died; at 5.0ppm, 16%; and at 3.5ppm, none, although they exhibited toxic symptoms

TNM has been characterized thru the Ames test as a mutagen

The toxic effects of TNM were for a time thought to be the same as those for nitrogen dioxide, and were attributed to possible breakdown of TNM to that compd. This is no longer considered a valid explanation

The accepted TLV of 1 ppm for industrial exposures to TNM may be too high; a TLV of 0.5 ppm has been proposed

Methyl Nitrate (Refs 18 & 26)

Methyl nitrate, a by-product of RDX and HMX manuf, boils at 65°C, and is quite volatile. It is extremely shock-sensitive. Methyl nitrate is apparently much weaker in its physiological effects than NG. Four-hour inhalation toxicity studies of its vapors gave LC50 values of 1275ppm (4000mg/m³) in rats and 5942ppm (18700mg/m³) in mice. Symptoms were lethargy, decreased respiratory rate (as with NG and cyanosis. Rats died during exposure or in the following 12 hours; mouse deaths were often delayed, ranging from 3 to 11 days post-exposure. Animals surviving 14 days after exposure appeared to recover completely. Oral LD50's were 344mg/kg in male rats, 1820mg/kg in male mice, and 548mg/kg in guinea pigs

In tests conducted on two human subjects, inhalation of 117 and 417mg, respectively, was required to induce headaches. Methyl nitrate was reported to have mutagenic effects on *Escherichia coli* bacteriophage T4B at 0.54 molar concn

Written by D. H. ROSENBLATT

Glossary of Toxicological Terms

acute toxicity test – a test to establish the level at which a toxicant shows a specific adverse effect on a specified percentage of a homo-

geneous group of test organisms in a specific short period of time

Ames test – a test to determine if a chemical can cause a microorganism to undergo genetic mutation, used as an indicator of more general mutagenicity

anemia – any condition in which the concn of blood cells and of hemoglobin is less than normal
angina – severe constricting pain in the chest due to inadequate circulation of blood to the heart muscle

aplastic anemia – anemia characterized by greatly decreased red blood cell formation as a result of defective function of the bone marrow
azotemia – uremia, ie, an excess of urea and other nitrogenous wastes in the blood

bioconcentration – the increase in concn of test material in or on test organisms (or specified tissues thereof) relative to the concn of test material in the ambient water

carcinogen – a cancer producing substance

carcinogenicity – ability to cause cancer

carcinoma – a type of cancer derived from epithelial (skin or skin-like) tissue

cataract – loss of transparency of the crystalline lens of the eye, or of its capsule

cerebellum – the posterior brain mass

cerebrospinal fluid – a liq comparable to serum that fills the ventricles and subarachnoid cavities of the brain and spinal cord

cholangiofibrosis – growth of fibrous tissue in the bile duct

chronic toxicity test – a test to establish the types of effects, if any, of a given daily dose or a given concn of toxic substance administered to organisms over a long period of time, typically a normal life span or cycle

conjugate – a molecule joined to a toxic compd to aid in the excretion of that compd

conjunctivae – mucous membranes covering the fronts of the eyeballs

cutaneous exposure – exposure to the penetration of toxic substance thru the skin

cyanosis – dusky bluish or purplish discoloration of the skin and mucous membranes due to deficient oxygenation of the blood

dura – a tough, fibrous membrane, forming the outer envelope of the brain

eleptiform seizures – convulsions that resemble attacks of epilepsy

edema – accumulation of excessive fluid in the

cells

flow-thru aquatic toxicity test – a toxicity test on aquatic organisms in which the test organisms are immersed in a flowing soln of the test substance, so that the test substance is maintained at a constant concn and waste products are continuously removed

gastritis – inflammation of the stomach, especially its mucous membranes

glucuronic acid – $\text{CHO}(\text{HCOH})_4\text{COOH}$, an oxidation product of glucose

glucuronide – a conjugate of some molecule, usually an alcohol or amine, with glucuronic acid

Heinz bodies – minute bodies seen (as the result of certain chemical intoxications) in red blood cells on dark ground illumination after staining with the dye azur I

hematuria – a condition in which the urine contains blood or red blood cells

hemolytic anemia – anemia resulting from abnormal destruction of red blood cells

hemosiderosis – accumulation in the tissues of yellowish-brown granules that contain very high concns of iron oxide; it may lead to destruction of the liver

hepatitis – inflammation of the liver

hepatocarcinoma – liver cell carcinoma

hepatocellular – referring to liver cells

hyperplasia – an abnormal increase in the cells of a tissue

icterus – jaundice

interstitial cell tumors – cancer of cells found between the semen-producing tubules of the testes

intraperitoneal – within the peritoneal (ie, abdominal) cavity

intravenous – with a vein

jaundice – yellowish pigmentation of skin, tissues, and certain body fluids, caused by deposition of bile pigments, and associated with liver disease

LAP – load, assemble, and pack, referring to a munitions plant operation

LC50 – concn of a test substance in water or air, under a specified set of conditions, that is lethal to 50% of the test organisms

LD50 – dose of a test substance that is lethal to 50% of a group of test organisms

leukocyte – any one of the types of white blood cells

leukocytosis – an abnormally large number of

leukocytes

lumbar – relating to the part of the back and sides between the ribs and pelvis

lymphocyte – a colorless, weakly motile leukocyte formed in lymphoid tissue; it constitutes 20–30% of the leukocytes in normal blood

metabolically activated Ames test – an Ames test (see above), in which the chemical to be tested has been subjected to the effects of certain liver cell fractions potentially capable of transforming the chemical to its metabolites, which may be mutagenically active

metabolites – the products resulting from the biochemical breakdown of a given chemical compd in a living organism

methemoglobin – a transformation product of normal oxyhemoglobin in which ferrous ion has been oxidized to ferric; methemoglobin cannot carry oxygen

methemoglobinemia – the presence of methemoglobin in circulating blood, often caused by chemicals such as nitrite salts

mg/kg – milligrams per kilogram, the usual quantitative expression of the dose of a drug or toxic substance administered to a test animal

mg/l – milligrams per liter

mg/m³ – milligrams per cubic meter, a quantitative expression for the concn of a toxic substance in air (as in inhalation tests)

mutagenicity – ability to induce genetic mutations, ie, changes in heritable characteristics

necropsy – autopsy; postmortem examination

neurasthenia – nervous exhaustion

neutrophilic leukocytosis – leukocytosis characterized by increase in a particular type of leukocytes called neutrophils, which normally constitute 54–65% of the leukocytes

normocytic-normochromic anemia – anemia in which the blood cells are of normal size and contain normal amounts of hemoglobin

nystagmus – rhythmic oscillation of the eyeballs

oral toxicity – toxicity measured by introducing a poison thru the mouth and digestive tract

OSHA – Occupational Safety and Health Administration, a federal agency in the USA

pancreatic – relating to the pancreas, which is the abdominal salivary gland

percentile – the value of a statistical variable that marks the boundary between any two consecutive intervals in a distribution of 100 intervals each containing 1% of the total population.

As used in the present context, nine would be the 90th percentile of the numbers 1 thru 10
petechiae – minute hemorrhagic spots in the skin

polyneuritis – inflammation of several peripheral nerves

ppm – parts per million, here used to indicate the number of molecules of a given volatile substance per million molecules of air

proteinuria – presence of excessive protein in the urine

proximal tubule – (proximal convoluted tubule) part of the nephron (functional unit of the kidney) concerned especially with resorbing sugar, sodium ion, and chloride ion

pulmonary – relating to the lungs

renal – relating to the kidneys

respiratory rate – rate of breathing

sensitization – exposure of an animal to a particular chemical (usually without apparent effect) so as to render that animal reactive to that chemical following subsequent exposures

SGOT – serum glutamic oxalacetic transaminase, an enzyme that catalyzes transfer of ammonia between certain organic compds (and whose measurement is used in medical diagnosis)

static aquatic toxicity test – a toxicity test on aquatic organisms in which the test organisms are immersed in the same test soln thruout the test duration (as opposed to a flow-thru aquatic toxicity test)

subacute toxicity test – a term sometimes applied to a subchronic toxicity test

subchronic toxicity test – a multiple dose toxicity test similar to a chronic test but conducted for significantly less time

subcutaneous – beneath the skin

sublingual – beneath the tongue

synergism – cooperative action of two or more physiologically active substances, such that the total effect is more than the sum of the two or more effects taken independently

TLV – threshold limit value, the concn level of a substance in air considered acceptable for exposure of industrial workers

toxicity – degree of poisonousness

tumor – an abnormal mass of tissue that grows more rapidly than normal and continues to grow after the stimuli that initiated the new growth cease (cancer being a malignant tumor)

vasodilator – an agent that induces widening of the blood vessels

- Refs (cited in article): 1) W.F. vonOettingen, "The Aromatic Amino and Nitro Compounds, Their Toxicity and Potential Dangers – A Review of the Literature", US Public Health Service, PubHealthBull No **271** (1941)
- 2) L.C. McGee et al, "Metabolic Disturbances in Workers Exposed to Dinitrotoluene", AmerJ-DigestiveDiseases **9**, 329 (1942) 3) W.F. vonOettingen et al, "Experimental Studies on the Toxicity and Potential Dangers of Trinitrotoluene (TNT)", PubHealthBull No **285**, US Public Health Service (1944) 4) M. Barsotti & G. Crotti, "Epileptic Attacks as Manifestations of Industrial Intoxication by Trimethylenetrinitramine (T4)", MedLavoro **40**, 107 (1949)
- 5) W. Vogel, "Hexogen Poisoning in Human Beings", Zent f Arbeitsmed u Arbeitsschutz **1**, 51 (1951) 6) A.S. Kaplan et al, "Human Intoxication from RDX", ArchEnvironHealth **10**, 877 (1965) 7) S.L. Merrill, "Ingestion of an Explosive Material, Composition C-4: A Report of Two Cases", US Army Vietnam (USARV) Med Bull **9**, 5 (1968) 8) A.I. Hollander & E.M. Colbach, "Composition C-4 Induced Seizures: A Report of Five Cases", MilitaryMed **134**, 1529 (1969) 9) W.J. Stone et al, "Toxic Effects Following Ingestion of C-4 Plastic Explosive", ArchIntMed **124**, 726 (1969)
- 10) J.H. Knepshield & W.J. Stone, "Toxic Effects Following Ingestion of C-4 Plastic Explosive", Ch 33 in W. Keup, Ed, **Drug Abuse**, Charles C. Thomas, Springfield, Ill (1972), 296
- 11) W.B. Ketel & J.R. Hughes, "Toxic Encephalopathy with Seizures Secondary to Ingestion of Composition C-4", Neurology **22**, 871 (1972)
- 12) B.P. McNamara et al, "The Toxicology of Cyclotrimethylenetrinitramine (RDX) and Cyclo-tetramethylenetetranitramine (HMX) Solutions in Dimethylsulfoxide (DMSO), Cyclohexanone, and Acetone", EATR **73040**, Edgewood Arsenal, Md (1973) 13) H.E. Stokinger et al, "Documentation of Threshold Limit Values for Substances in Workroom Air", 3rd ed, Amer Conference of Governmental Industrial Hygienists, 2nd Printing (1974), 270 14) J.C. Dacre & D.H. Rosenblatt, "Mammalian Toxicology and Toxicity to Aquatic Organisms of Four Important Types of Waterborne Munitions Pollutants—An Extensive Literature Evaluation", USAMBRDL Tech Rept No **7403** (1974) (AD 778725) 15) E.R. Hart, "Subacute Toxicity of RDX and TNT in Monkeys", Final Rept, Contract N00014-73-C-0162, Litton Bionetics, Inc, Kensington, Md (1974) (AD A044650)
- 16) M.J. Small & D.H. Rosenblatt, "Munitions Production of Potential Concern as Waterborne Pollutants – Phase II", USAMBRDL Tech Rept No **7404** (1974) (AD 919031) 17) E.R. Hart, "Subacute Toxicity of RDX and TNT in Dogs", Final Rept, Contract N00014-73-C-0162, Litton Bionetics, Inc, Kensington, Md (1974) (AD A035717) 18) W.R. Mura et al, "Munitions-Related Substances of Potential Concern as Airborne Pollutants", USAMBRDL Tech Rept No **TR 7409** (1974) (AD B001198L) 19) C.-C. Lee et al, "Mammalian Toxicity of Munitions Compounds, Phase I: Acute Oral Toxicity, Primary Skin and Eye Irritation, Dermal Sensitization, and Disposition and Metabolism", Final Rept No **1**, Midwest Res Inst, Kansas City, Mo, Contract DAMD 17-74-C-4073 (1975) (AD B011150L)
- 20) G.W. Newell et al, "Mammalian Toxicological Evaluations of TNT Wastewater ("Pink Water")", Final Rept, Contract DAMD 17-74-C-4115, Stanford Res Inst, Menlo Park, Ca (1976) (AD A044785) 21) N.R. Schneider et al, "Toxicology of Cyclotrimethylenetrinitramine (RDX): Distribution and metabolism in the Rat and the Miniature Swine", Armed Forces Radiobiol Inst, AFRRRI Sci Rept No **76-34** (1976) 22) C.-C. Lee et al, "Mammalian Toxicity of Munitions Compounds. Phase II: Effects of Multiple Doses. Part III: 2,6-Dinitrotoluene", Final Rept No **4**, Contract DAMD 17-74-C-4073, Midwest Res Inst, Kansas City, Mo (1976) (AD A062015) 23) E.R. Hart, "Two-Year Feeding Study in Rats", Final Rept, Contract N00014-73-C-0162, Litton Bionetics, Inc, Kensington, Md (1976) (AD A040161) 24) H.V. Ellis, III et al, "Mammalian Toxicity of Munitions Compounds. Phase II: Effects of Multiple Doses. Part IV: Nitrocellulose", Final Rept No **5**, Contract DAMD 17-74-C-4073, Midwest Res Inst, Kansas City, Mo (1976) (AD A062016) 25) Anon, DARCOM Regulation 40-3 (10 Nov 1976) 26) E.R. Kinkead et al, "Toxic Hazards Evaluation of Five Atmospheric Pollutants from Army Ammunition Plants", Aerospace Med Res Lab Rept **AMRL-TR-77-25** and USAMBRDL Tech Rept No **7703** (1977) (AD A043957) 27) N.R. Schneider et al, "Toxicology of Cyclotrimethylenetri-

- nitramine Distribution and Metabolism in the Rat and the Miniature Swine", *ToxicolAppl-Pharmacol* **39**, 531 (1977) 28) V.F. Simmon et al, "Mutagenicity of Some Munition Waste-water Chemicals and Chlorine Test Kit Re-agents", Final Rept, Contract DAMD 17-76-C-6013, SRI International, Menlo Park, Ca (1977) 29) R.E. Bentley et al, "Laboratory Evaluation of the Toxicity of Nitrocellulose to Aquatic Organisms", Final Rept, Contract DAMD 17-74-C-4101, E G & G, Bionomics, Wareham, Mass (1977) 30) C.-C. Lee et al, "Mammalian Toxicity of Munitions Compounds. Phase II: Effects of Multiple Doses. Part I: Trinitroglycerin", Final Rept No 2, Contract DAMD 17-74-C-4073, Midwest Res Inst, Kansas City, Mo (1977) 31) R.E. Bentley et al, "Laboratory Evaluation of the Toxicity of Cyclotrimethylene Trinitramine (RDX) to Aquatic Organisms", Final Rept, Contract DAMD 17-74-C-4101, E G & G, Bionomics, Wareham, Mass (1977) 32) N.R. Schneider et al, "The Distribution and Metabolism of Cyclotrimethylenetrinitramine (RDX) in the Rat After Subchronic Administration", *ToxicolApplPharmacol* **46**, 163 (1978) 33) S. Zakhari et al, "Occupational Health and Safety of 2,4,6-Trinitrotoluene (TNT)", Final Rept, Contract DAMD 17-77-C-7020, Franklin Inst Res Labs, Philadelphia, Pa (1978) 34) J.V. Dilley et al, "Mammalian Toxicological Evaluation of TNT Wastewaters. Vol II. Acute and Subacute Mammalian Toxicity of TNT and the LAP Mixture", Final Rept, Contract DAMD 17-76-C-6050, SRI International, Menlo Park, Ca (1978) 35) C.-C. Lee et al, "Mammalian Toxicity of Munitions Compounds. Phase III: Effects of Life-Time Exposure. Part I: 2,4-Dinitrotoluene", Final Rept No 7, Contract DAMD 17-74-C-4073, Midwest Res Inst, Kansas City, Mo (1978) 36) Ibid, "Mammalian Toxicity of Munitions Compounds. Phase II. Effects of Multiple Doses. Part II: 2,4-Dinitrotoluene", Final Rept No 3, Contract DAMD 17-74-C-4073, Midwest Res Inst, Kansas City, Mo (1978) 37) T.M. Wendt et al, "Microbial Degradation of Glycerol Nitrates", *ApplEnv-Microbiol* **36**, 693 (1978) 38) H.V. Ellis, III et al, "Mammalian Toxicity of Munitions Compounds. Phase III: Effects of Life-Time Exposure. Part II: Trinitroglycerin", Final Rept No 8, Contract DAMD 17-74-C-4073, Midwest Res Inst, Kansas City, Mo (1978) 39) H.V. Ellis et al, "Mammalian Toxicity of Munitions Compounds. Phase I: Acute Oral Toxicity, Primary Skin and Eye Irritation, Dermal Sensitization, Disposition and Metabolism, and Ames Tests of Additional Compounds", Final Rept No 6, Contract DAMD 17-74-C-4073, Midwest Res Inst, Kansas City, Mo (1978) 40) Anon, "Fed Water Pollution Control Act of 1972, as Amended by Clean Water Act of 1977", *Environment Reporter, Fed Laws* **71** (Dec 8, 1978), 5101 ff 41) D.H.W. Liu et al, "Toxicity of TNT Wastewaters to Aquatic Organisms. Vol I. Acute Toxicity of LAP Wastewater and 2,4,6-Trinitrotoluene", Final Rept, Contract DAMD 17-75-C-5056, SRI International, Menlo Park, Ca (1978) 42) H.V. Ellis et al, "Mammalian Toxicity of Munitions Compounds. Phase III: Effects of Life-Time Exposure. Part III: Nitrocellulose", Final Rept No 9, Contract DAMD 17-74-C-4073, Midwest Res Inst, Kansas City, Mo (1979) 43) J.H. Sullivan, Jr et al, "A Summary and Evaluation of Aquatic Environmental Data in Relation to Establishing Water Quality Criteria for Munitions Unique Compounds. Part 2: Nitroglycerin", Final Rept, Contract DAMD 17-77-C-7027, Water and Air Research, Inc, Gainesville, Fla (1979) 44) J.H. Sullivan, Jr et al, "A Summary and Evaluation of Aquatic Environmental Data in Relation to Establishing Water Quality Criteria for Munitions Unique Compounds. Part 4: RDX and HMX", Final Rept, Contract DAMD 17-77-C-7027, Water and Air Research, Inc, Gainesville, Fl (1979) 45) J.V. Dilley et al, "Mammalian Toxicological Evaluation of TNT Wastewaters. Vol III. Acute and Subacute Mammalian Toxicity of Condensate Water", Final Report, Contract DAMD 17-76-C-6050, SRI International, Menlo Park, Ca (1979) 46) H.V. Ellis, III et al, "Mammalian Toxicity of Munitions Compounds. Summary of Toxicity of Nitrotoluenes", Final Rept No 11, Contract DAMD 17-74-C-4073, Midwest Res Inst, Kansas City, Mo (1979) 47) J.G. Pearson et al, "An Approach to the Toxicological Evaluation of a Complex Industrial Wastewater", *ASTM Special Tech Pub* No **667**, 284 (1979) 48) A.M. El-hawari et al, "Evaluation of Difference in Mammalian Metabolism of Trinitrotoluene (TNT) as a Function of Route of Administration", Final Rept, Contract

DAMD 17-76-C-6066, Midwest Res Inst, Kansas City, Mo (1979)

Refs to E & P materials not discussed in above article:

Pentaerythritol Tetranitrate (PETN): a) W.F. vonOettingen et al, "Toxicity and Potential Dangers of Penta-Erythritol-Tetranitrate (PETN)", US Public Health Service, Pub Health Bull No 282 (1944) b) F.J. Sullivan et al, "Acute Effects of Pentaerythritol Tetranitrate on Various Myocardial, Hemodynamic and Metabolic Parameters in the Normal Anesthetized Dog", ArchInternPharmacodyn 147, 229 (1964) c) F.J. DiCarlo et al, "Absorption, Distribution and Excretion of Pentaerythritol and Pentaerythritol Tetranitrate by Mice", ProcSocExptl-BiolMed 117, 311 (1965) d) F.J. DiCarlo, "The Biotransformation of Pentaerythritol Tetranitrate as Related to Host Defense Reactions", JReticuloendothelSoc 4, 190 (1967) e) Ibid, "The Absorption and Biotransformation of Pentaerythritol Tetranitrate-1,2-¹⁴C by Rats", BiochemPharmacol 16, 309 (1967) f) Ibid, "Sites of Absorption of Pentaerythritol Tetranitrate", ArchIntPharmacodynTher 167, 163 (1967) g) I.E.F. Davidson et al, "Absorption, Excretion, and Metabolism of Pentaerythritol Tetranitrate by Humans", JPharmacolExpTher 175, 42 (1970) h) F.J. DiCarlo et al, "Pharmacodynamics and Biotransformation of Pentaerythritol Tetranitrate in Man", JPharmSci 60, 274 (1971)

Picric Acid and Ammonium Picrate: a) L. Schwartz, "Dermatitis from Explosives", JAmerMedAssoc 125, 186 (1944) b) F.W. Sunderman et al, "Studies of the Effects of Ammonium Picrate on Man and Certain Experimental Animals", JIndHygieneToxicol 27, 241 (1945) c) A.H. Harris et al, "Hematuria Due to Picric Acid Poisoning at a Naval Anchorage in Japan", AmJPublicHealth 36, 727 (1946) d) P. Shubick & J.L. Hartwell, "Survey of Compounds Which Have Been Tested for Carcinogenic Activity", Suppl II, Government Printing Office, Washington, DC (1969) e) F. Huidobro, "Action of Picric Acid on the Effects of Some Drugs Acting on the Central Nervous System, with Special Reference to Opioids", ArchIntPharmacodynTher 192, 362 (1971) f) H.C. Maguire, Jr & P. Coghlan, "The Rapid Adjuvant

Effect in the Acquisition of Delayed Hypersensitivity to Low Molecular Weight Sensitizers in the Guinea Pig", IntArchAllergyApplImmuno 41, 679 (1971) g) H.E. Stokinger et al, "Documentation of Threshold Limit Values for Substances in Workroom Air", 3rd ed, Amer Conf of Governmental Industrial Hygienists, 2nd printing (1974) h) D. Burrows & J.C. Dacre, "Toxicity to Aquatic Organisms and Chemistry of Nine Selected Waterborne Pollutants from Munitions Manufacture - A Literature Evaluation", USAMBRDL Tech Rept No 7503 (1975) (AD A010660) i) M. Windholz, ed, "The Merck Index", 9th ed, Merck & Co, Inc, Rahway, NJ (1976) j) R.L. Baer, "Allergic Contact Sensitivity", CUTIS 17, 861 (1976)

Propylene Glycol Dinitrate: a) R.A. Jones et al, "Toxicity of Propylene Glycol 1,2-Dinitrate in Experimental Animals", ToxicolApphPharmacol 22, 128 (1972) b) M.E. Andersen & R.G. Mehl, "Comparison of the Toxicology of Triethylene Glycol Dinitrate and Propylene Glycol Dinitrate", AmerIndHygieneAssJ 34, 526 (1973)

Tetryl: a) W.J. McConnell et al, "Occupational Diseases in Government-Owned Ordnance Explosives Plants", OccupMed 1, 551 (1946) b) E. Daniele, "Hemocoagulative Modifications in Chronic Experimental Poisoning by Tetryl", FoliaMed (Naples) 47, 767 (1964) c) S. Fati & E. Daniele, "Histopathological Changes in Experimental Chronic Tetryl Intoxication", FoliaMed (Naples) 48, 269 (1965)

Triethylene Glycol Dinitrate: M.E. Andersen & R.G. Mehl, "Comparison of the Toxicology of Triethylene Glycol Dinitrate and Propylene Glycol Dinitrate", AmerIndHygieneAssJ 34, 526 (1973)

Toxoi. A high expl (TNT 70 & Trinitroxylyene 30%) used by the Brit as an ingredient of Amatol (see Vol 1, A165-L). Similar expls were used by the Russians under the names Ammoksil or Ammonxyl (see Vol 1, A286-R)

TPEON. Acronym for Tripentaerythritol Octanitrate (see in this Vol)

TPX. Acronym for Torpex (see in this Vol)

Tracers. See under "Pyrotechnics" in Vol 8, P508-R to P510-R

Track Torpedo. Same as "Railroad Torpedo" (see in this Vol)

Trajectory, Projectile. A trajectory may be defined as the curve in space traced by the center of gravity of a projectile in its flight thru the air (Fig 1)

The *origin* of a trajectory is the position of the center of gravity of the projectile at the instant it is released by the projecting mechanism; the tangent to the trajectory at its origin is the *line of departure*; the angle this line makes with the horizontal is the *quadrant angle of departure*. The vertical plane including the line of departure is the *plane of departure*. In it lie the X (horizontal) and Y (vertical) axes of the coordinate system used in the computation of trajectories, whereas the Z axis lies in the horizontal plane and is perpendicular to the plane of departure. To describe a trajectory completely it is sufficient to specify the x, y and z coordinates of the center of gravity of the projectile at any time, t (ie, at every instant), after the release by the projecting mechanism

The factors which influence the shape of the trajectory of a specified projectile after it leaves the launching device are principally the earth's gravitational field and the characteristics of the air thru which the projectile passes. The design of the projectile and the methods used to stabilize it have a considerable effect on the trajectory. For example, the rotation imparted to a projectile by the rifling in the gun causes it to move

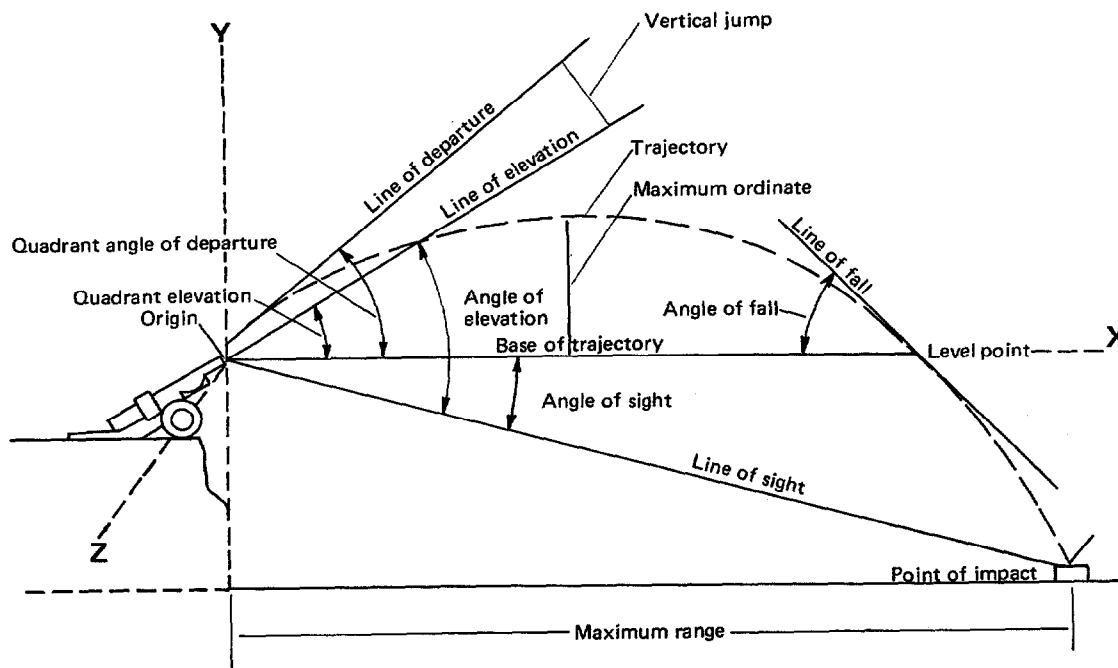

Fig 1 Elements of the Artillery Trajectory

out of the plane of departure due to a cross-wind force resulting from gyroscopic precession (see Vol 8, P366-R) of the projectile nose. The density of a projectile has a direct influence on both its stability and range

For a detailed discussion of the principles of exterior ballistics, see the Refs

Refs: 1) C. Cranz, "Lehrbuch der Ballistik", Vol 1, Berlin (1925); and "Ergänzungsband", Berlin (1936) 2) T.J. Hayes, "Elements of Ordnance", J. Wiley & Sons, NY (1938), 397-468 3) H.V. Wagner, *Ordn* 37, 340 (1952) 4) Anon, *EngrgDesHndbk*, "Elements of Armament Engineering, Part Two, Ballistics", **AMCP 706-107** (1963) 3-1 to 3-20

Tramex (Swiss). Trade name of a powdered NG-sensitized expl distributed in Switzerland by Vereinigung Schweizevischer Sprengstoffabriken. Its d is 1.1g/cc, wt strength 77%, and Pb block test 335-40cc/10g

Ref: R. Meyer, "Explosives", Verlag Chemie, NY (1977), 296

Transport of Hazardous Materials. See under "Storage and Transport" in article entitled, "Safety in the Energetic Materials Field" in this Vol

Addnl Refs: 1) M.F. Smith, "Hazardous Materials Transportation. Part I. General Studies (A Bibliography with Abstracts)", NTIS, Springfield (1976), (NTIS/PS-76/0331/9WK). [The transportation of expls, rocket proplnts, chemical warfare agents, industrial chemicals, liquefied natural gas, chlorine, and other hazardous materials are covered. All means of transportation are described] 2) L.W. Bierlein, "Red Book on Transportation of Hazardous Materials", UNZ & Co, 190 Baldwin Ave, Jersey City, NJ 07036 (1977), \$65

Trauzl Dynamite. Contained NG 75, NC 23 and charcoal 2%. It could be detonated with a strong cap even if it absorbed up to 15% moisture

Refs: Daniel (1902), 722 2) Giua, *Trattato* 6 (1) (1959), 343

Trauzl Test (Lead Block Expansion Test). See Vol 1, XXV to XXVI; Vol 2, B266 to B295 (Table 1, column titled Power, Method of Detg, TT); and Vol 8, P365-R

Tremonite S.II. Ger permissible coal mining expl used prior to and following WWI. It contained Dinitroglycerin 33, AN 26.5, Na chloride 25, TNT 2.5, meal 12, and collodion cotton 1%
Ref: Barnett (1919), 139

Trempage des poudres (Fr). Steeping or soaking of proplnt grains. Some plants, engaged in the manuf of progressive burning proplnts, used a preliminary treatment which consisted of soaking the grains for a long time (ie, 30 hrs) in hot w (80°), prior to treating the surface of the grains with an alcoholic soln of a phlegmatizer such as camphor, centralite, etc. This treatment was intended to cause the grains to swell and thus facilitate the penetration of the alcoholic soln into the grains

See also under "Arrosage des Poudres" in Vol 1, A488-R

Ref: J. Fauveau, *MP* 31, 162 & 165 (1949)

Trench Mortar. See Vol 2, C28-L and Vol 8, M156-R to M157-L

Trench's Explosive. A mixt of BlkPdr with perchlorates such as K perchlorate or Amm perchlorate

Ref: A. Trench, *BritP* 8358 (1908) & *CA* 3, 2507 (1909)

Triacetin (TA or Glyceryl Triacetate). See under "Acetins and Derivatives" in Vol 1, A31-R to A32-L, and under "Propellants, Solid" in Vol 8, P406-R to P407. The current Mil Spec for "Triacetin (Glyceryl Triacetate)" is **MIL-T-301A (2)**, dated 31 July 1973

Triacetone Triperoxide (Acetoneperoxide, Trimeric or Acetonetriperoxide). See Vol 1, A42-R to A45-L

Triacetoneitrile Oxide. See Vol 8, N105-L

Trialen, Trialene or Tetranol. Same as Torpex (see in this Vol)

Triamine, Diethylene (2,2'-Diaminodiethylamine). $(\text{NH}_2\text{CH}_2\text{CH}_2)_2\text{NH}$, $\text{C}_4\text{H}_{13}\text{N}_3$; mw 103.17; N 40.74%; yel hygr liq; mp -39° ; bp 270° ; d 0.9856g/cc at 20/20 $^\circ$; RI 1.4810 at 25 $^\circ$. V sol in ethanol and w; sol in ligr; insol in eth. CA Registry No [111-40-0]. Prepn is by reacting ethylenechloride with aq ammonia at 115–20 $^\circ$

This compd is unique in that it has been used as both a *sensitizer* for liq expls at low temps (ie, below its fr pt), and as a time-delay *desensitizer* in expl formulations at RT. Thus, Runge and Edwards (Ref 2) state that the triamine (10–12 wt %), together with Nitromethane contg methylene chloride (7:3 wt ratio; 90 to 88 wt %), can be detonated at -60° . Ridgeway (Ref 3), on the other hand, claims that prior to the addition of diethylene triamine, an expl contg 10p of N_2H_4 and 85p of Nitromethane could be detonated ($>6300\text{m/sec}$) in a 25mm diam column using a No 8 blasting cap. The addition of 5p of diethylene triamine to the formulation, after a 4-hr time lapse, resulted in no detonation under the same condition

Refs: 1) Beil 4, 255 & [695] 2) W.F. Runge & D.W. Edwards, "Low Temperature Liquid Explosive Composition", USP 3798092 (1974) & CA 81, 79926 (1974) 3) J.J. Ridgeway, "Nitroparaffin Explosive Mass", GerP 2546953 (1976) & CA 85, 80525 (1976)

Triaminoguanidine, Its Nitrate and Salts. See under "TAGN" in this Vol

1,2,3-Triaminopropane and Its Derivative

The parent compd is used as the hydrochloride in the synthesis of expl derivs

1,2,3-Triaminopropane Hydrochloride.

$\text{H}_2\text{N}\cdot\text{CH}_2\cdot\text{CH}(\text{NH}_2)\cdot\text{CH}_2\cdot\text{NH}_2\cdot 3\text{HCl}$; mw 198.55; N 21.17%; white cryst; mp 223–26 $^\circ$. Sol in w. Prepn is by hydrolysis of ethyl-1,2,3-propane carbamate with concd HCl

Refs: 1) Beil 4, 274 & [714] 2) T. Curtius & O. Hesse, JPraktChem 62, 262 (1900)

1,2,3-Trinitroaminopropane (Glyceryltrinitramine, TNAPr or NGX). $(\text{O}_2\text{N}\cdot\text{HN})\text{CH}_2\cdot\text{CH}(\text{NH}\cdot\text{NO}_2)\cdot\text{CH}_2(\text{NH}\cdot\text{NO}_2)$, $\text{C}_3\text{H}_8\text{N}_6\text{O}_6$; mw 224.17; N 37.50%; OB to CO_2 –28.55%; cryst; mp 132–33 $^\circ$ (decompn); d 1.630g/cc. Sol in acet and w; sl sol in ethanol and nitromethane; insol in eth. Prepn is by nitrating 1,2,3-triaminopropane triurethane with mixed (98%) nitric acid-acetic anhydride at -5° . The resulting nitrourethane is then treated with anhydr gaseous ammonia (ammonolysis)

NGX has an expln temp of 241.0 $^\circ$, and a vac stab at 100 $^\circ$ for 40 hrs of 0.51cc/g, and at 120 $^\circ$ for 40 hrs of 1.53cc/g

Refs: 1) Beil, not found 2) A.T. Blomquist & F.T. Fiedorek, OSRD 4134 (1944), 23 & 99–101 3) Anon, "Arthur D. Little Punch Card . . . Explosives", Vol 1, Card Set 01.10, p 19; 01.13, p 18; 54.01, p 17; & 54.03, p 16, Arthur D. Little, Cambridge, Mass (1961)

Triaminotetroxide, Chromium. See in Vol 3, C302-L

2,4,6-Triamino-1,3,5-Triazine. See in Vol 3, C589-L under "Cyanuramide, Melamine or 2,4,6-Triamine-sym-triazine"

1,3,5-Triamino-2,4,6-Trinitrobenzene. See under "TATB" in this Vol

s-Triazaborane (Borazine, Hexahydro-s-triazaborine, Borazole, Triborine triamine, or Triboron nitride).

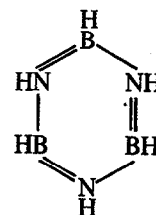

$\text{B}_3\text{H}_6\text{N}_3$; mw 80.53; N 52.18%; mobile liq; mp -58° ; bp 53 $^\circ$; d₄ 0.824g/cc; RI 1.3821. Sol in w. CA Registry No [6569-51-3]. Prepn is by heating an equimolar mixt of ammonia and B

hydride at 250–300° for 30 mins. The compd detonates with a grn-violet flash when mixed with O₂ and exposed to a spark (Ref 2). Samples in sealed glass ampules have detonated on exposure to ultra-violet radiation (Ref 3)

Refs: 1) Gmelin, System No 22, Teil 4 (1975), 323–24 2) E.M. Smolin & L. Rapoport, "S-Triazines and Derivatives", Interscience, NY (1959), 603 3) Bretherick (1975), 190–91 4) Merck (1976), 1234 (No 9283)

1,3,5-Triaza Cyclohexane, 1,3-Dinitro-5-Nitroso (or NOX). See in Vol 7, H75-L under "Hexahydro-1,3-dinitro-5-nitroso-5-triazine"

1,3,5-Triaza Cyclohexane-5-Nitrate, 1,3-Dinitro (or PCX). See in Vol 7, H75-R under "Hexahydro-1,3-dinitro-1,3,5-triazine, Nitrate, PCX"

2,4,6-Triazaheptane, 1,7-Bis (Difluoroamino).

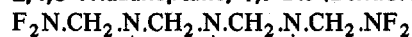

$C_4H_8F_4N_8O_6$; mw 340.19; N 32.95%; OB to CO₂ –28.22%; white cryst; mp 176–77°. Sol in ethanol. Prepn is by treating a chl f soln of Diacetoxy-2,4,6-Trinitro-2,4,6-Triazaheptane with gaseous difluoroamine in the presence of a ring-sulfonated styrene-divinyl benz copolymer (acting as a catalyst) at –120°, under anhydr and air-free conditions while stirring. The resulting mixt is then held at 50° for ≥ 72 hrs, with subsequent removal of volatiles under vac. The crude product is sublimed off at 110° and with subsequent crystn from ethanol, a 43% yield is obtd. Results from an Al block dent test indicate that the compd is 10% more powerful than PETN. The inventors (Ref 2) claim that calcs indicate the performance level of proplnts will be improved by inclusion of this compd

Refs: 1) Beil, not found 2) R.K. Armstrong & G.L. Brennan, USP 3558708 (1971) & CA 74, 101285 (1971)

2,4,6-Triazaheptane, 1,7-Diacetoxy-2,4,6-Trinitro (BSX). See in Vol 5, D1119-L & R and the following *Addnl Ref:* R.E. Cobbleddick & R.W. Small, "... Crystal Structure of 1,7-Diacetoxy-

2,4,6-Trinitro-2,4,6-Triazaheptane", ActaCryst, B 1973, 29 (part 12) 2795–98 & CA 80, 53332 (1974) [From (X-ray) counter data the crysty of BSX is found to be monoclinic, space group C2/C, with a=26.935 (4), b=9.174 (1), c=6.122 (1) Å, β=101.35 (3)°, & Z=4. Least squares resolution of atomic positional and anisotropic thermal vibrational parameters gives an R of 0.115]

1,3,5-Triaza-n-Pentane-5-Nitrate, 1,3-Dinitro.

NO₂.NH.CH₂.N(NO₂).CH₂.NH₂.HNO₃, C₂H₈N₆O₇; mw 228.16; N 36.84%; OB to CO₂ –7.01%; cryst; mp 129°. Sol in acet; neutralized by aq Na hydroxide. Prepn is by diln of a hexamine dinitrate-nitric acid reaction mixt with eth at 0°, resulting in a gum. Evapn of the eth from the reaction mixt by addn of methanol with rapid stirring at RT, is then followed by recrystn of the resulting residue formed, after filtrn, with 80% nitric acid. The yield is 22%. Calcd power of the expl is 154% TNT (Ref 3) *Refs:* 1) Beil, not found 2) K.W. Dunning & J.W. Dunning, "... The Reaction of Hexamine Dinitrate with Nitric Acid at Low Temperatures", JCS 1950, 2920–24 & CA 45, 6642 (1951) 3) Anon, "Synthesis of High Explosives", 3rd Rept, Arthur D. Little, Boston (1953), 145

Triazenes. Derivatives of HN:N(NRR) which may also be considered the parent fragment of diazoamino compds, R.N:N.NH.R or R'.N:N-N(RR). The nitrogen to which the R' group is attached will be noted as either Roman numeral I or N¹, the second nitrogen as II or N², and the nitrogen to which RR (or HR) are attached as III or N³. The reason for using this style of nomenclature is given under "Tetrazenes" in this Vol. The use of Arabic numerals is reserved for the ring groups attached to nitrogens in the parent fragment. See in Vol 7, H224-L & R under "Hydronitrogens" and the following *Addnl Compds:*

N¹-Amino-N¹-Phenyl-N³-(Tetrazolyl-5)-Triazene. See in Vol 1, A247-R to A248-L under "N¹ ... N³ ... -Triazene"

Bis (Tetrazolyl)-Triazene and Derivatives. See in Vol 2, B158L & R

N¹-Carboxamide-N-Guanyl Triazene [Triazendi-carbonsäure-amid-amidin (Ger)]

$\text{H}_2\text{N.CO.N:N.NH.C(:NH).NH}_2 + \text{H}_2\text{O}$, $\text{C}_2\text{H}_8\text{N}_6\text{O}_2$; mw 132.16; N 63.60%; OB to CO_2 +24.21%; yel ndles (from hot w); mp, decomp explosively at 95° , puffs off at 139° on rapid heating. V sol in alkalies; sl sol in w. Prepn is by gently warming N-aminoiminomethyl-N-carbonic acid ethyl ester-triazene with ammonia. The compd forms expl salts such as the **Hydrochloride**, $\text{C}_2\text{H}_6\text{N}_6\text{O} + \text{HCl}$; mw 167.09; N 50.31%; OB to CO_2 +4.79%; white cryst; mp, explds on prolonged heating at $100-10^\circ$ or on rapid heating ca 139° . Sol in w; nearly insol in ethanol and other organic solvents. Prepn is by slowly adding diazoguanidinecyanide to hydrochloric acid at $60-70^\circ$ with subsequent rapid cooling. Another expl salt is the **Nitrate**, $\text{C}_2\text{H}_6\text{N}_6\text{O} + \text{HNO}_3$; mw 193.16; N 50.77%; OB to CO_2 -210.18%; shiny cryst; mp, explds at 136° without melting

Refs: 1) Beil 3, 128 2) J. Thiele & N. Osborne, Ann 305, 71-74, 77-78 (1899)

Dimethyltriazene. See in Vol 5, D1376R to D1377-L

N¹,N-Di-[3,5-Dinitro-2-Hydroxy Toluene]

Triazene[(3,5,3',5'-Tetranitro-2,2'-dihydroxy-4,4'-dimethyl-dibenzene-triazene, Dinitrodiazoamidodinitrocresol, or 3,5,3',5'-Tetranitro-2,2'-dioxy-4,4'-dimethyl-diazoaminobenzol (Ger)]. $(\text{O}_2\text{N})_2(\text{HO}).\text{C}_6\text{H}(\text{CH}_3).\text{N:N.NH}(\text{CH}_3).\text{C}_6\text{H}(\text{OH})(\text{NO}_2)_2$, $\text{C}_{14}\text{H}_{11}\text{N}_7\text{O}_{10}$; mw 437.32; N 22.43%; OB to CO_2 -85.98%; golden-yel lflts; mp, explds violently at ca 160° . Prepn is by reaction of nitrous acid with an ethanolic soln of 2,6-dinitro-4-amino-3-oxy-1-methyl-benzene

Refs: 1) Beil 16, 720 2) O. Emmerling & A. Oppenheim, Ber 9, 1095 (1876)

N¹,N-Di-[p-Nitrophenyl]-Triazene [4,4'-Dinitrodiazoaminobenzene, Paradinitrodiazoaminobenzene, Di-p-dinitrodiazoaminodiphenol or Di-(nitro-4-phenyl)-triazene (Ger)]. $\text{O}_2\text{N.C}_6\text{H}_4.\text{N:N.NH.C}_6\text{H}_4.\text{NO}_2$, $\text{C}_{12}\text{H}_9\text{N}_5\text{O}_4$; mw 287.26; N 24.39%; OB to CO_2 -136.46%; yel ndles (from ethanol), orange-yel lflts (from benz); mp $220-36^\circ$.

Sol in aq solns of alkalies; sl sol in hot ethanol, acet, chlf and benz. Prepn is by treating p-nitrobenzenediazonium chloride with 5-amino-tetrazole. This expl compd forms expl salts such as the **Cobalt Salt**, $\text{Co}(\text{C}_{12}\text{H}_8\text{N}_5\text{O}_4)_2$, bluish-grey flakes; **Copper Salt**, $\text{Cu}(\text{C}_{12}\text{H}_8\text{N}_5\text{O}_4)_2$, chocolate-colored amorph powder; **Silver Salt**, $\text{AgC}_{12}\text{H}_8\text{N}_5\text{O}_4$, bright red powder; **Sodium Salt**, $\text{NaC}_{12}\text{H}_8\text{N}_5\text{O}_4$, bluish-grey shining ndles, v sl sol in ethanol and aq alkaline solns

Refs: 1) Beil 16, 700 & (406) 2) R. Meldola & F.W. Streatfield, JCS 49, 6267-69 (1886) 3) Ibid, 51, 445-51 (1887) 4) E. Bamberger, Ber 27, 1952 (1894) 5) R. Meldola & F.W. Streatfield, JCS 67, 50 (1895) 6) M.O. Forster, JCS 107, 265 (1915) 7) R. Stollé et al, Ber 62, 1125 (1929)

1,3-Diphenyl-Triazene-(1) and Derivatives. See in Vol 5, D1156-R under "Diazoaminobenzene"

N',N-Diphenyl-N'-Nitroso-Triazene.

$\text{C}_6\text{H}_5.\text{N.N:N.C}_6\text{H}_5$, $\text{C}_{12}\text{H}_{10}\text{N}_4\text{O}$; mw 226.26; N 24.77%; OB to CO_2 -198.00%; bright yel cryst; mp, decomp at -10° . Sol in nitrobenz (reacts) and chlorobenz (reacts). Prepn is by reacting N',N-Diphenyl-N'-Na-triazene with nitrosyl chloride at -40° . The compd is termed very expl

Refs: 1) Beil, not found 2) E. Müller & H. Haiss, "N-Nitroso-Triazene", Ber 95, 1255-60 (1962) & CA, not found

1,3-Di-[Tetrazolyl-(5)-Triazene]. See in Vol 5, D1157-R

N¹-Hydroxy-N-Azidoiminomethyl-Triazene. See in Vol 5, D1164-L under "Diazoquanylazide..."

1,3-Di- α -Naphthyltriazene. See in Vol 5, D1158-L under "Diazoaminonaphthalene"

N¹-Phenyl-N-Carboxylic Acid Anilide (1 or 3-Phenyl-triazene-(1)-carbonic acid-(3 or 1)-anilide). $\text{C}_6\text{H}_5.\text{N:N.N.NH.CO.NH.C}_6\text{H}_5$, $\text{C}_{13}\text{H}_{12}\text{N}_4\text{O}$; mw 240.29; N 23.32%; OB to CO_2 -206.42%; fine ndles (from hot benz); mp 141° (decompn). V sol in chl; easily sol in ethanol and hot benz; not sol in w; difficultly sol in eth. Prepn is by reaction of phenyltriazene with phenylisocyanate in eth at -18° . The complex forms expl

salts such as the **Nitrile** [or 1 or 3-Phenyl-(3 or 1)-cyanotriazene-(1)], $C_6H_5.N:N.NH.CN$, $C_7H_6N_4$; mw 146.17; N 38.34%; colorl lflts or ndles which become yel on exposure to ultra-violet light; mp 72° (explds). Easily sol in ethanol; sol in eth; diff sol in benz, ligr and w. Prepn is by acidifying the K salt of the nitrile in an ice-cold v dil aq soln with acetic acid. The K salt, in turn, may be prepd by heating azidobenzene in ethanol in the presence of KOH. The nitrile explds on heating or impact. **Phenyl Triazene Carboxylic Acid Secondary Hydrazide**, $C_6H_5.N:N.NH.CO.NH.NH.CO.NH.N:N.C_6H_5$, $C_{14}H_{14}N_8O_2$; mw 326.36; N 34.34%; OB to CO_2 -161.78%; ndles; mp 162° (decompn). Sol in benz and eth. Prepn is by diazotization of carbohydrazide chlorohydrate. The product explds on rapid heating above its mp
Refs: 1) Beil **16**, 691 & (404) 2) L. Wolff & H. Lindenbayn, Ber **37**, 2376-79 (1904) 3) O. Dimroth, Ber **40**, 2387 (1907) 4) R. vonWalther & W. Grieshammer, JPraktChem **92**, 254 (1915) & CA **10**, 592 (1916) 5) A. Bertho, JPraktChem **116**, 110 (1927) & CA **21**, 2903 (1927)

N¹-Phenyl-N-Hydroxy-N-p-Aminophenyl-Triazene (1-Phenyl-3-[4-aminophenyl]-3-oxy-triazene-(1) or Benzoldiazo-[4-amino-phenylhydroxylamide]). $C_6H_5.N:N.N(OH).C_6H_4(NH_2)$, $C_{12}H_{12}N_4O$; mw 228.28; N 24.55%; OB to CO_2 -203.26%; mp 125° (decompn). V sl sol in alkalies and w. Prepn is by reacting a dil ethanolic soln of 4-nitrosoaniline with phenylhydrazine hydrochloride. The product explds on rapid heating
Refs: 1) Beil **16**, 740 2) O. Fischer & L. Wacker, Ber **21**, 2610 (1888) 3) E. Bamberger, Ann **420**, 152 (1920) & CA **14**, 2925 (1920)

N¹-Phenyl-N-Hydroxy-N-4-Ethylaminophenyl-Triazene (p-Ethylaminobenzenediazohydroxyaminobenzene or Benzodiazo-[4-äthyliminophenylhydroxylamid] (Ger)). $C_6H_5.N:N.N(OH).C_6H_4.NH.C_2H_5$, $C_{14}H_{16}N_4O$; mw 257.34; N 21.78%; OB to CO_2 -217.61%; yel prisms; mp $122-23^\circ$ (decompn). Sol in benz, ethanol and eth; sl sol in ligr; v sl sol in alkalies and w. Prepn is by reacting an aq soln of p-nitroso-N-ethyl aniline hydrochloride with an

acetic acid soln of phenyl hydrazine. The product explds on rapid heating
Refs: 1) Beil **16**, (414) 2) O. Fischer & W. Johannes, JPraktChem [2], **92**, 63 (1915) & CA **10**, 183 (1916)

N¹-Phenyl-N¹-Oxy-N-Benzene Sulfonyl-Triazene [3-Benzolsulfonyl-1-phenyl triazen-(1)-oxyd-(1) (Ger)]. $C_2H_5.(O:)N:N.NH.SO_2.C_6H_5$, $C_8H_{11}N_3O_3$; mw 197.22; N 21.31%; OB to CO_2 -150.09%; ndles; mp 102° (decompn). Prepn is by reacting N,N'-dibenzolsulfonylhydrazine with nitrobenzene in the presence of an alkali. The product is both impact and heat sensitive, and is considered to be a violent expl
Refs: 1) Beil **16**, (414) 2) A. Angéli, Atti della Reale Accademia dei Lincei (Rendiconti), [5] **24**, I, 1098 (1915) & CA, not found

N¹-Phenyl-N-Toluene Sulfonyl-N-Benzene Sulfonyl-Triazene [Benzoldiazo-p-toluol sulfonyl-sulfanilsaure (Ger)]. $C_6H_5.N:N.N:(SO_2.C_6H_4.CH_3).C_6H_4.SO_3H$, $C_{18}H_{17}N_3O_5$; mw 355.38; N 11.83%; OB to CO_2 -177.84%; ndles; mp, explds above 100° . V sl sol in w; not sol in ethanol and eth. Prepn is by reacting benzoldiazonium chloride with N-p-toluolsulfonyl-sulfonic acid in w
Refs: 1) Beil **16**, (411) 2) Agfa, GerP 229247, ChemZtr **191**, I, 180 & CA, not found

N¹-1-Tetrazolyl-N-p-Nitrophenyl-Triazene (1-Tetrazolyl-3-p-nitrophenyl triazene or Tetrazolyl-[nitro-4-phenyl]-triazene (Ger)).

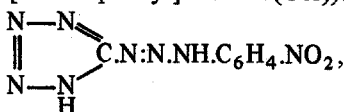

$C_7H_6N_8O_2$; mw 234.21; yel prisms; mp $165-69^\circ$ (explds mildly). Sol in hot ethanol; sl sol in eth; insol in w. Prepn is by treating a soln of tetrazolediazonium chloride with an aq suspension of p-nitroaniline, using Al or enameled vessels (not glass) to prevent expln
Refs: 1) Beil, not listed 2) R. Stollé et al, Ber **62**, 1125 (1929) 3) F.R. Benson, Chem-Revs **41**, 9 (1947) & CA **41**, 6885 (1947)

Triazides. A listing of expl inorganic triazides can be found in Vol 1, A 521-L to A625-L.

The listing includes:

Aluminum Triazide, to be found on A521-L;
Antimony Triazide, to be found on A522-R;
Boron Triazide, to be found on A525-L & R;
Chromium Triazide, to be found on A530-L & R;
Cobalt Triazide, to be found on A531-L & R; and
Thalious-Thallic Azide, to be found on A623-R to A624-L

The following are some organic Triazides which are expl:

Cyanuric Triazide. See in Vol 3, C590-R to C591-L, and under "Triazines" in this Vol

The Triazide of Δ^2 Pyrazoline-(3,4,5)-Tricarboic Acid.

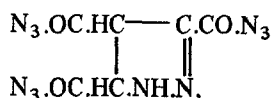

$\text{C}_6\text{H}_3\text{N}_{11}\text{O}_3$; mw 277.20; N 55.60%; OB to CO_2 -60.61%; expl oil. Sol in eth. Prepn is by reaction of Δ^2 -pyrazoline-(3,4,5)-tricarboic acid-trihydrazide with an excess of Na nitrite. The triazide is then pptd as the hydrochloride in the cold. The compd explds on heating

Ref: Beil 25, 556

The Triazide of Pyrazole-(3,4,5)-Tricarboic Acid.



$\text{C}_6\text{H}_3\text{N}_{11}\text{O}_3$; mw 275.18; N 56.00%; OB to CO_2 -55.24%; cryst; mp, explds on heating. Sol in eth. Prepn is by reacting pyrazole-(3,4,5)-tricarboic acid-trihydrazide with Na nitrite and hydrochloric acid in the cold

Ref: Beil 25, 557

1,3,5-Triazido-2,4,6-Trinitro-Benzene (TNTAB).

See in Vol 2, B43-R to B44-R and the following Addnl Refs: 1) Davis (1943), 436-38 [The following expl properties are reported: A brisance of 160% TNT; a heat of combustion at C_v of 2500cal/g; slight hygry (storage for 40 days in a satd atm increased the wt 1.35%); an impact sensy of 30cm (using a 2-kg wt, MF ref is 5cm), when mixed with ground glass it becomes as

sensitive as MF; initiating action, 1 g of TNT compressed to 300kg/cm^2 requires for its initiation 0.02g of TNTAB, while 1 g of Tetryl requires 0.01g; TNTAB is stable in RT storage for several years, but starts to decomp quickly at 50° , and at 100° the azide decomp completely in 14 hrs, losing nitrogen and forming Hexanitrosobenzene. When exposed to sunlight TNTAB turns brownish in color] 2) Anon, EngrgDesHndbk, "Explosives Series-Properties of Explosives of Military Interest", AMCP 706-177 (1971), 378-80 [Addnl reported properties are: An exudation value of "none on storage"; a heat of combustion of 2554cal/g; and a burning rate of 0.65cm/sec]

Tricarballic Acid Triazide.

$\text{N}_3.\text{CO.CH}_2.\text{CH}(\text{CO.N}_3).\text{CH}_2.\text{CO.N}_3$, $\text{C}_6\text{H}_5\text{N}_9\text{O}_3$; mw 251.20; N 50.20%; OB to CO_2 -73.25%; yel expl oil with a heavy odor. Sol in ethanol and eth; insol in w. Prepn is by reacting tricarballic acid trihydrazide hydrochloride with a soln of Na nitrite at 0°
 Ref: Beil 2, 817

Tricarboic Acid Triazide.

$\text{N}_3.\text{CO.CH}_2.\text{CH}(\text{CO.N}_3)_2$, $\text{C}_5\text{H}_3\text{N}_9\text{O}_3$; mw 237.17; N 53.16%; OB to CO_2 -57.34%; oil; mp, explds violently when heated. Prepn is by reacting ethyltetracarboic acid trihydrazide salt with Na nitrite dissolved in hydrochloric acid
 Ref: Beil 2, (321)

Triazines

Triazines are six-membered heterocyclic compds contg three nitrogen and three carbon atoms.

There are three types of triazine ring structures:

Vicinal; vic, or 1,2,3-triazine:

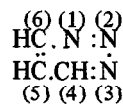

CA Registry No [289-96-3]. This parent structure does not exist in nature, nor has it been synthesized

Asymmetrical; asym, or 1,2,4-triazine:

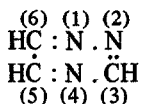

CA Registry No [290-38-0]. Here too, the parent structure does not exist in nature, nor has it been synthesized

Symmetrical; sym, or 1,3,5-triazine:

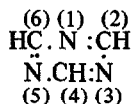

CA Registry No [290-87-9]. See in Ref 4 for this parent structure's properties and synthesis

When one or several $-\text{CH}$ groups are substituted for by $-\text{CO}$ groups, the resulting compds are called oxy-, dioxy-, etc. . . triazines. If a $-\text{CH}$ group is replaced by $-\text{C-OH}$, the compd is called "hydroxytriazine" (Refs 3 & 4)

The expl triazines are listed alphabetically below, according to parent structure type
 Refs: 1) Beil 26, (65 ff) & [3 ff] 2) G.N.R. Smart & R.V.V. Nicholls, "The Chemistry of the Triazines", CDRB 3963, McGill Univ, Canada (1942) 3) J.G. Erickson, P.F. Wiley & V.P. Strach, "The 1,2,3- and 1,2,4-Triazines . . .", Interscience, NY (1956), 3-4 & 44-45
 4) E.M. Smolin & L. Rapoport, "s-Triazines and Derivatives", Interscience, NY (1959), 6-10
 5) Karrer (1950), 834 6) ChemRubHndbk (1978), C33-C55 7) H. Neunhoeffler & P.F. Wiley, "Chemistry of 1,2,3-Triazines . . . and Pentazines", J. Wiley, NY (1978)

The Vicinal or 1,2,3-Triazines

4-Amino-1,2,3-Triazolo [4,5-d] 1,2,3-Triazine-3-Oxide.

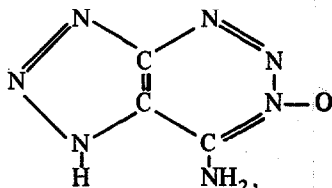

$\text{C}_3\text{H}_3\text{N}_5\text{O}$; mw 125.11; N 55.99%; OB to CO_2 -83.13%; cryst; mp, 206° (expl decompn).

Prepn is by treating 5-amino-1,2,3-triazole-4-carboxamidoxime with nitrous acid

Refs: 1) Beil, not found 2) H. Neunhoeffler & P.F. Wiley, "Chemistry of 1,2,3-Triazines and

1,2,4-Triazines . . .", J. Wiley, NY (1978)

4-Amino-2(2H)-Imino-s-Triazino [1,2-c] [1,2,3] Benzotriazine.

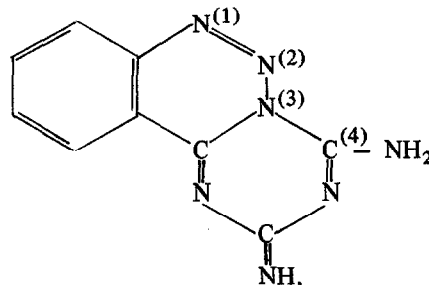

$\text{C}_9\text{H}_7\text{N}_7$. mw 213.23; N46.10%; cream colored solid; mp $> 200^\circ$ (with effervescence); v sl sol in nonpolar solvents; decomp in polar solvents. Prepn is by diazotization of 2,4-diamino-6-(2-aminophenyl)-1,3,5-triazine in 2N hydrochloric acid with subsequent basification using ammonium hydroxide to obtain the desired product in 85% yield. The triazine explds on maceration
 Refs: 1) Beil, not found 2) M.F.G. Stevens & S.M. Mackenzie, "Triazines and Related Products . . .", JCS (C) 1970 (17), 2298-2308 & CA 74, 13107 (1971)

Benzo (-1,2,3-) Triazine and Derivatives. See in Vol 2, B86-R to B87-L

1,2,3-Benzotriazinium Betaine-1,4-Oxides. These triazines form a group of expls with the following general structure and properties:

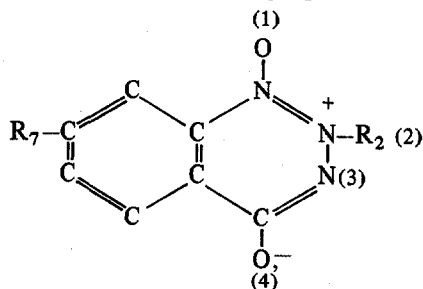

$\text{C}_7\text{H}_6\text{N}_3\text{O}_2\text{R}_2\text{R}_7$; mw $164.16 + \text{R}_2 + \text{R}_7$; yel crystn compds; sol in concd hydrochloric acid and hot ethanol. The compds are stable at RT for indefinite lengths of time (Ref 12, pp 88-90). Table 1 presents specific properties of these compds. Prepn, in general, is by halogenation of 2-nitrobenzaldehyde arylhydrazones (with an R_7 fragment already attached), followed by treatment with a base contg the R_2 fragment

Table 1
Specific Properties of Various Explosive 1,2,3-Benzotriazinium Betaine-1,4-Oxides

Fragment Nomenclature, (See Text for Key)		Quant Elemental Formula	Total MW	N, %	OB to CO ₂ , %	Expln Temp, °C	Refs
R ₂	R ₇						
Methyl	H	C ₈ H ₁₀ N ₃ O ₂	180.21	23.32	-168.69	145-157	9, 11, 12
Phenyl	H	C ₁₃ H ₁₂ N ₃ O ₂	242.28	17.35	-198.12	145	9, 11, 12
4-Methyl Phenyl (or Toly)	H	C ₁₄ H ₁₄ N ₃ O ₂	260.31	16.15	-202.84	142-143	3, 11, 12
4-Chloro Phenyl	H	C ₁₃ H ₁₁ N ₃ O ₂ Cl	276.72	15.19	-267.09	147	2, 12
4-Bromo Phenyl	H	C ₁₃ H ₁₁ N ₃ O ₂ Br	321.17	13.09	-146.96	144-146	2, 10, 11, 12
4-Nitro Phenyl	H	C ₁₃ H ₁₁ N ₄ O ₄	295.28	21.69	-149.28	145-146	9, 11, 12
4-Methoxy Phenyl	H	C ₁₄ H ₁₄ N ₃ O ₃	272.31	15.43	-188.02	141	9, 11, 12
2,4-Dichloro Phenyl	H	C ₁₃ H ₁₀ N ₃ O ₂ Cl ₂	311.16	13.51	-149.12	140	2, 12
2,4-Dibromo Phenyl	H	C ₁₃ H ₁₀ N ₃ O ₂ Br ₂	400.04	10.51	-115.98	145-146	2, 9, 12
2-Methyl-4-Bromo-Phenyl	H	C ₁₄ H ₁₃ N ₃ O ₂ Br	325.20	12.54	-155.13	151	5, 12
4-Methyl-2-Chloro-Phenyl	H	C ₁₃ H ₁₃ N ₃ O ₂ Cl	278.74	15.08	-175.29	134	4, 12
4-Methyl-2-Bromo-Phenyl	H	C ₁₄ H ₁₃ N ₃ O ₂ Br	335.20	12.54	-155.13	139	3, 12
4-Methyl-2-Bromo-Phenyl	nitro	C ₁₄ H ₁₂ N ₄ O ₄ Br	380.20	14.74	-126.25	133	6, 12
2-Nitro-4-Bromo-Phenyl	H	C ₁₃ H ₁₀ N ₄ O ₄ Br	366.17	15.30	-117.98	142	5, 12
2,4,6-Trichloro Phenyl	H	C ₁₃ H ₉ N ₃ O ₂ Cl ₃	345.60	12.16	-131.94	163	2, 12
3,4,5-Trichloro Phenyl	H	C ₁₃ H ₉ N ₃ O ₂ Cl ₃	345.60	12.16	-131.94	151	2, 12
2-Methyl-4,6-Dibromo Phenyl	H	C ₁₄ H ₁₃ N ₃ O ₂ Br ₂	415.10	10.13	-125.27	145	5, 12
4-Methyl-2,6-Dichloro Phenyl	H	C ₁₃ H ₁₂ N ₃ O ₂ Cl ₂	313.18	13.42	-153.27	155	5, 12
4-Methyl-2,6-Dibromo Phenyl	H	C ₁₄ H ₁₃ N ₃ O ₂ Br ₂	415.10	10.13	-125.27	167	3, 12
4-Methyl-2,6-Dibromo Phenyl	nitro	C ₁₄ H ₁₁ N ₄ O ₄ Br ₂	479.09	11.70	-98.52	142	6, 12
5-Methyl-2,4-Dibromo Phenyl	H	C ₁₄ H ₁₃ N ₃ O ₂ Br ₂	415.10	10.13	-125.27	126	8, 12
2,3,4,5-Tetrabromo Phenyl	H	C ₁₃ H ₈ N ₃ O ₂ Br ₄	557.84	7.53	-80.31	155	7, 12
Penta Chloro Phenyl	H	C ₁₃ H ₇ N ₃ O ₂ Cl ₅	414.48	10.14	-106.16	128	7, 12
Penta Bromo Phenyl	H	C ₁₃ H ₇ N ₃ O ₂ Br ₅	636.73	6.60	-69.10	157	7, 12

Refs: 1) Beil, not found 2) F.D. Chattaway & A.J. Walker, JCS **127**, 2407 (1925) & CA **20**, 175 (1926) 3) F.D. Chattaway & A.B. Adamson, JCS **1930**, 157 & CA **24**, 1853 (1930) 4) Ibid, **1930**, 843 & CA, not found 5) Ibid, **1931**, 2787-92 & CA **26**, 703 (1932) 6) Ibid, 2792-96 & CA **26**, 704 (1932) 7) D. Chattaway & G.D. Parkes, "Derivatives of 3,5-Dihalogen-Substituted Anilines", JCS **1935**, 1005-08 & CA **29**, 6579 (1935) 8) G.D. Parkes & E.D'A. Burney, "Derivatives of 6-Bromo- and 4,6-Dibromo-m-Toluidine", JCS **1935**, 1619-21 & CA **30**, 1034 (1936) 9) M.S. Gibson, Tetrahedron **18**, 1377 (1962) & CA, not found 10) R.C. Kerber, "Azimines. I. Reinvestigation of Some Alleged Azimines", JOrgChem **1972**, 37 (10), 1587-92 & CA **77**, 34464 (1972) 11) A. McKillop & R.J. Kobylecki, "Structures of Some Benzo-1,2,3-Triazinium Betaines", JOrgChem **1974**, 39 (18), 2710-14 & CA **81**, 12054 (1974) 12) H. Neunhoeffler & P.F. Wiley, "Chemistry of 1,2,3-Triazines and 1,2,4-Triazines, . . .", J. Wiley, NY (1978), 88-90

5H-Imidazo [4,5-d] 1,2,3-Triazine-4 (3H)-Ones.
These triazines form a group of expls with the following general structure and properties:

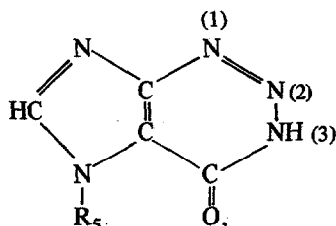

$C_4H_5N_5OR_5$; mw $119.10 + R_5$; yel (or brn) cryst; sol in ethanol; v sl sol in w. Specific compd properties are shown in Table 2. Prepn is by

cyclization of the appropriate 5-diazoimidazole-4-carboxamide in aq soln over a wide pH range

Refs: 1) Beil, not found 2) R.P. Panzica & L.B. Townsend, JHeterocyclChem **9**, 623 (1972) & CA **77**, 62271 (1972)

7H-Imidazo [4,5-d] 1,2,3-Triazine-4 (3H)-Ones.
These triazines form a group of expls with the following general structure and properties:

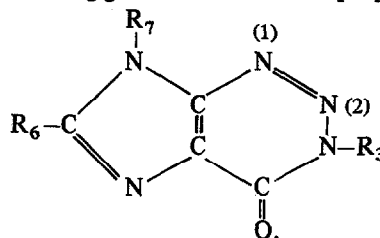

$C_4N_5OR_3R_6R_7$; mw $134.09 + R_3 + R_6 + R_7$; yel (or brn) crystn compds; sol in ethanol; v sl sol in w. Prepn of the various derivs are given in the pertinent refs in Table 3, as are the properties of these expl triazines

Refs: 1) Beil, not found 1a) D.W. Wooley & E. Shaw, JBiolChem **189**, 401 (1951) & CA, not found 2) Y.F. Shealy et al, JOrgChem **26**, 2396 (1961) & CA, not found 3) Y.F. Shealy, C.A. Krauth & J.A. Montgomery, JOrgChem **27**, 2150 (1962) & CA **57**, 4649 (1962) 4) R.P. Panzica & L.B. Townsend, JHeterocyclChem **9**, 623 (1972) & CA, not found 5) J.A. Montgomery & H.J. Thomas, JMedChem **15**, 182 (1972) & CA **76**, 107849 (1972) 6) M. Kauana et al, JMedChem **15**, 841-43 (1972) & CA **77**, 122007 (1972) 7) R.J. Rousseau & G.A. Ivanovics, USP 3803126 (1974) & CA **80**, 146489 (1974) 8) H. Neunhoeffler & P.F. Wiley, "Chemistry of 1,2,3-Triazines and 1,2,4-Triazines . . .", J. Wiley, NY (1978), 120-25

Table 2
Specific Properties of Various Explosive 5H-Imidazo[4,5-d] 1,2,3-Triazine-4(3H)-Ones

Fragment Nomenclature (See Text for Key) R_5	Quant Elemental Formula	Total MW	N, %	OB to CO_2 , %	Expln Temp, $^{\circ}C$	Refs
CH_3	$C_5H_4N_5O$	150.14	46.66	-111.90	199-200	2
$C_5H_5O_4(\beta\text{-D-Ribofuranosyl})$	$C_9H_6N_5O_5$	264.20	26.51	-96.90	184-185	2

Table 3
Specific Properties of Various Explosive 7H-Imidazo[4,5-d] 1,2,3-Triazine-4(3H)-Ones

Fragment Nomenclature (See Text for Key)			Quant Elemental Formula	Total MW	N, %	OB to CO ₂ , %	Expln Temp, °C	Refs
R ₃	R ₆	R ₇						
H	H	H	C ₄ H ₃ N ₅ O	137.11	51.09	-99.19	204-208	1a, 3
H	H	CH ₃	C ₅ H ₅ N ₅ O	151.15	46.34	-121.73	205-206	6
H	H	C ₅ H ₅ O ₄ (β-D-Ribofuranosyl)	C ₉ H ₇ N ₅ O ₅	265.21	26.41	-99.54	173-175	4, 5, 6, 7

The Asymmetrical or 1,2,4-Triazines

Amino (-1,2,4-) Triazines and Derivatives. See in Vol 1, A267-L & R

4,5-Dihydro-1,4-Diphenyl-3,5-Phenylimine-1,2,4-Triazole. See in Vol 8, N137-L & R under "Nitron"

m-Nitrophenyl-Azo-1-[3,5-Dioxy-6-Dimethyl-1,2,4-Triazine] (1-[3-Nitro-benzoldiazo]-3,5-dioxy-6,6-dimethyl-hexahydro-1,2,4-triazin [Ger])

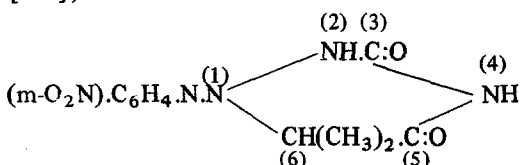

C₁₁H₁₂N₅O₄; mw 278.28; N 25.17%; OB to CO₂ -137.99%; pale yel silvery flakes (from aq alc); mp, explds ca 130°. Sol in aq ethanol. Prepn is by treating 3,5-diazo-6,6-dimethyl-hexahydro-1,2,4-triazine with a soln of m-nitrobenzenediazonium chloride. The triazine also forms an expl **Potassium Salt**; bright vermilion colored ndles; expl decompn ca 166°; obtd by treating α-ureido-α-m-nitrophenylene diazoamino-i-butyric acid ethyl ester with K ethylate; sol in ethanol

Refs: 1) Beil **26**, 222 2) J.R. Bailey & L. Knox, JACS **29**, 889-90 (1907) & CA **1**, 2798 (1907)

The Symmetrical or 1,3,5-Triazines

1-Acetyl-3,5-Dinitro-1,3,5-Triazacyclohexane or TAX. See in Vol 1, A50-L & R

Aminobenzotriazines and Derivatives. See in Vol 1, A189-R to A190-L

1-Aminohexahydro-2,4,6-Triamino-sym-Triazine. See in Vol 1, A216-L

Amino (-1,3,5-) Triazines. See in Vol 1, A267-L

Ammeline and Derivatives. See in Vol 1, A273-R to A174-L

Cyanuric Triazide. See in Vol 3, C590-R to C591-L and the following *Addnl Refs*: 1) S. Oinuma, JapP 7524419 (1975) & CA **84**, 108014 (1976) [The inventor claims a cyanuric triazide compn contg 43.2% of the triazide (CA Registry No 5637-83-2) with a density of 0.56g/cc and a friction sensy of 3-3.5kg. Thus, 5.5g of cyanuric trichloride is added slowly to a mixt of 3g of polyvinyl butyral, 45ml of methylketone, 7ml of 2,3-butanediol, and 6.5g of Na azide at 5-10°. The compn is stirred with 5g shredded filter paper, dried to form a sheet, extracted with cold w, and then redried] 2) R. Meyer, "Explosives", Verlag Chemie, NY (1977), 55-56 [Reported for cyanuric triazide are: An energy of formation of +1088kcal/kg (+4551kJ/kg); an enthalpy of formation of +1071kcal/kg (+4481

kJ/kg); an oxygen balance of -47%; and a friction sensy of 0.01kp pistil load]

5,7-Diamino-3-Amyl (or 3-Pentyl)-s-Triazolo-[4,3-a]-s-Triazine. See in Vol 5, D1126-R

2,4-Diamino-6-Methyl-s-Triazine. See in Vol 5, D1140-R to D1141-L

2,4-Diamino-s-Triazine. See in Vol 5, D1146-R to D1147-L

Hexahydro-1,3-Dinitro-5-Nitroso-5-Triazine (NOX). See in Vol 7, H75-L

Hexahydro-1,3-Dinitro-1,3,5-Triazine Nitrate (PCX). See in Vol 7, H75-R

Hexahydro-1-(Methoxymethyl)-3,5-Dinitro-s-Triazine. See in Vol 7, H75-R

Hexahydro-1-Methyl-3,5-Dinitro-s-Triazine. See in Vol 7, H76-L

Hexahydro-1,3,5-Trinitroso-s-Triazine (also called 1,3,5-Trinitroso-trimethylene triamine). See in Vol 3, C630-R to C633-L, and the following *Addnl Ref*: P.G. Hall, "Thermal Decomposition and Phase Transitions in Solid Nitramines", *TransFaradSoc* **1971**, (67/pt 2), 556-62 & *CA* **74**, 103832 (1971) [Reported are DSC values for enthalpy changes in fusion; ΔH_f at 376°K = 0.90 ± 0.03 kcal/mole; transition, ΔH_t at 365°K = 4.25 ± 0.15 kcal/mole]

Hexakis (2,2,2-Trinitroethyl)-Melamine. See in Vol 7, H77-L & R

Melamine and Derivatives. See in Vol 8, M55-R to M56-L and the following *Addnl Ref*: E.M. Smolin & L. Rapoport, "S-Triazines and Derivatives", Interscience, NY (1959), 374-75 ["... Melamine has been suggested (C. Mannelli & L. Bernardini, USP 1409963 (1922) & *CA*, not found) as one component of a stable, easily handled explosive mixture, the other components of which are ammonium perchlorate or ammonium nitrate and carbon. When melamine is added to nitrocellulose or mixtures of nitroglycerin and nitrocellulose, the product is said (Anon, GerP 201215 (1908) & *CA*, not found)

to be a gelatinous explosive characterized by a low combustion temp and increased effectiveness..."]

1,1'-(Oxydimethylene)-Bis-[Hexahydro-3,5-Dinitro-s-Triazine]. See in Vol 8, O57-R

1,3,5-Triazine-Trioxide (Trifulmin). See in Vol 8, N105-R

1,3,5-Trinitrohexahydro-s-Triazine (RDX, Cyclonite). See in Vol 3, C611-L to C630-L, and in this Vol under "RDX"

1,3,5-Trinitrosohexahydro-s-Triazine (Trimethylene trinitrosoamine, TMTN, or 1,3,5-Trinitroso-1,3,5-triazacyclohexane).

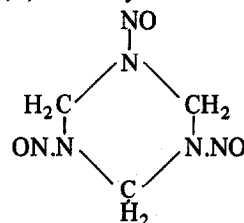

$C_3H_6N_6O_3$; mw 174.15; N 48.27%; OB to CO_2 -55.12%; cryst; mp 105-07°; sp grav 1.508. Sol in acet; sl sol in methyl alc and toluene; v sl sol in eth and w. Prepn is by reaction of nitric acid at pH 1-2 with hexamethylenetetramine at <8°. Yield is 84% of theoretical. The product is decompd explosively at RT on contact with sulfuric acid

TMTN has a heat of deton of 850kcal/g; at d 1.57g/cc it is detond by 2.5g of MF; impact sensy is the same as TNT (a 5-kg wt gives 0% deton at 20cm, and 100% at 50cm); Pb block value is 125.5 (PA 100); deton vel of 7800m/sec at 1.57g/cc; RT stability is 6 years; deflagration temp is 300°

Oxidation of the triazine using H_2O_2/HNO_3 yields RDX

Refs: 1) Beil **26**, 6 & (3) 2) Urbański **3** (1967), 121-24

2,4,6-Tripicryl-s-Triazine (TPT, N²,N⁴,N⁶-Tripicryl melamine, or 2,4,6-Tripicryl-1,3,5-triazine).

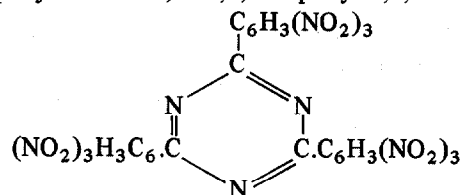

$C_{21}H_9N_{12}O_{18}$; mw 717.42; N 23.43%; OB to CO_2 -63.56%; bright yel crystals; mp 352–53°; d 1.75g/cc (TMD), 1.724g/cc (from m-dichlorobenzene). Sol in boiling m-dichlorobenzene, hot acet-methanol and most org solvents. CA Registry Nos [49753-54-0 & 27158-19-7]. Prepn is by treatment of N^2, N^4, N^6 -triphenylmelamine with mixed acid below 70° (Ref 3). The triazine may also be obtd by reacting cyanuric chloride with 2,4,6-(O_2N) $_3C_6H_2Br$ in the presence of Cu in nitrobenz (Ref 4)

TPT has a deton vel (at d 1.75g/cc) of 7420 m/sec; a ΔH_c° of 2256.0 ± 1.9 kcal/mole; an impact sensy of 320cm (using a 2.5-kg wt); and is thermally stable up to 300°

According to Ref 6, TPT has been selected as a prime candidate for use in spacecraft hardware by NSW for NASA

Refs: 1) Beil, not found 2) J.C. Dacons & M.E. Sitzmann, "Heat Resistant Explosives XXVI. The Synthesis and Properties of 2,4,6-Tripicryl-s-Triazine, TPT", **NOLTR 68-64** (1968) 3) M.D. Coburn, USP 3414570 (1968) & CA **70**, 47505 (1969) 4) J.C. Dacons, USP 3755321 (1973) & CA **79**, 126530 (1973) 5) Ibid, "2,4,6-Tripicryl-s-Triazine, TPT; Its Crystallization and Crystal Density Determination", **NSWC/WOL/TR 76-16** (1976) (AD-A023464) 5a) P.E. Rouse, Jr, *JChemEngrgData* **21**, (1), 16–20 (1976) & CA **84**, 92352 (1976) 6) Anon, "The Development of Spacecraft Explosives for the Lyndon B. Johnson Space Center", NSW, **NASA-CR-147547** (1975) & CA **85**, 145386 (1976) 7) J.C. Dacons & M.E. Sitzman, "Synthesis of 2,4,6-Trinitrophenyl Derivatives of Heterocyclic Compounds", *JHeterocyclChem* **1977**, 14 (7), 1151–55 & CA **88**, 121112 (1978)

2,4,6-Tris-Picrylamino-s-Triazine.

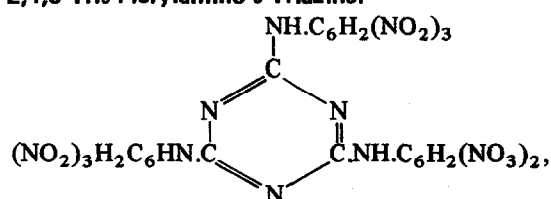

$C_{21}H_9N_{15}O_{18}$; mw 759.45; N 27.67%; OB to CO_2 -60.04%; cryst; mp > 300° (decompn), DTA exotherm at 325°; d 1.75g/cc. Prepn is by nitration of 2,4,6-trianilino-s-triazine with a mixt

of nitric acid/acetic anhydr/acetic chloride at 70°. The compd has an impact sensy of 320cm Refs: 1) Beil, not found 2) M.D. Coburn, *JHeterocyclChem* **3** (3), 365–66 (1966) & CA **65**, 20126 (1966)

2,4,6-Tris (Picrylnitramino)-s-Triazine.

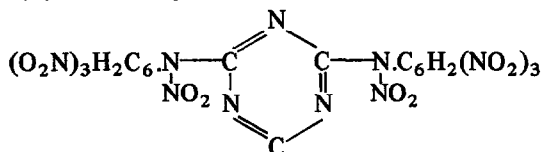

$C_{21}H_6N_{18}O_{24}$; mw 766.45; N 32.90%; OB to CO_2 -43.84%; cryst; mp > 100° (rapid decompn); d 1.73g/cc. Prepn is by nitration of 2,4,6-tris (picrylamino)-s-triazine with nitric acid/acetic anhydr mixt at < 50°. The picryl triazine has an impact sensy of 49cm Refs: 1) Beil, not found 2) M.D. Coburn, *JHeterocyclChem* **3** (3), 365–66 (1966) & CA **65**, 20126 (1966)

Triazoacetic Acid. See Vol 1, A27-L

Triazoacetone. See Vol 1, A39-R

Triazoethane. See Vol 6, E143-L

Triazoethanol Nitrate. See Vol 6, E177-L & R under "Ethanol Azido Nitrate . . ."

TRIAZOLES

The triazoles are five-membered heterocyclic ring compds consisting of three nitrogen and two carbon atoms. There are two types of triazole ring structures:

2) *v*-Triazole or 1H-1,2,3-Triazole;

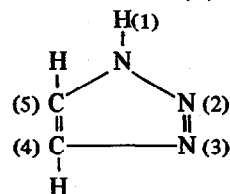

CA Registry No [288-36-8]. This structure also exists as the tautomeric forms, 2H-1,2,3-Triazole with a CA Registry No [288-35-7], and in a 4H-form, which is relatively rare

2) *s*-Triazole or 1H-1,2,4-Triazole;

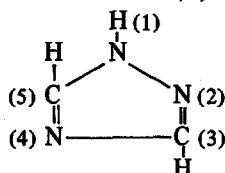

CA Registry No [288-88-0]. The tautomeric form for this structure is the 4H-form

The first 1,2,4-triazoles were prepd in 1885 by J.A. Bladin (Ber 18), who did considerable work in the investigation of this class of compd; H. vonPechmann published a paper in 1888 in which he described the prepn of some derivatives of 1,2,3-triazoles and proposed naming them "Osotriazones" because they were prepd from "osazone". This name was changed in 1891 by vonPechmann to "osotriazole". A. Andreocci also investigated triazoles, and in 1889 and 1894 published papers in which he called some of them "Pyrrodiazoles". All of these compds are now called "triazoles"

Triazole derivatives have such typical nomenclature as benzo-, hydroxy-, dioxy-, etc

Triazole expl derivatives are presented below alphabetically under each parent structure type
 Refs: 1) Beil 26, 11, 13 & (5) 1a) A. Andreocci, Ber 25, 225 (1892) 1b) G. Pellizzari, GazzChimItal 24, II, 225 (1894) 1c) A. Hantzsch & O. Silberrad, Ber 33, 85 (1900), & JCS Abs 68, I, 308 (1895) 1d) Karrer (1950), 802 2). R.C. Elderfield, Ed, "Heterocyclic Compounds—Volume 8—Tetrazoles . . .", J. Wiley, NY (1967) 3) A.R. Katritzky & A.J. Boulton, Eds, "Advances in Heterocyclic Chemistry", Vol 16, Academic Press, NY (1974), 33—85

1,2,3-Triazole (v-Triazole)

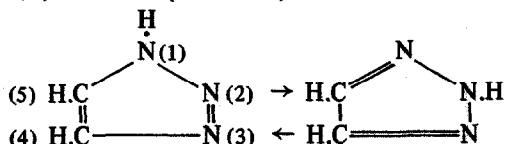

Note: Equilibrium of the 1H- and 2H-tautomers is favored in dil solns. The 1H-form is favored in concd soln and in the vapor phase. The 4H-form usually exists as an *open* chain, and in

derivative form as a Vinyl Azide; $C_2H_3N_3$; mw 69.07; N 60.85%; hydr crystals; mp 23° ; bp 203° at 739mm (according to Ref 2 superheating may lead to expl decompn of the vapors); d 1.1861 g/cc at $25/4^\circ$; RI 1.4854 at 25° . Sol in acet, ethanol and w. CA Registry Nos [288-36-8 & 288-35-7]. Prepn is by heating an ethanolic soln of hydrazoic acid with a soln of acetylene in acet in a closed system at 100° for 70 hrs. The Silver Salt, $AgC_2H_2N_3$; mw 175.94; N 23.89%; white ndles; insol in ammonia; explds mildly when heated

Refs: 1) Beil 26, 11 & (5) 2) M. Ishikawa & I. Kikkaua, AnnReptShionogiResLab No 4, 36—38 (1954) & CA 50, 15517 (1956)

Aminobenzotriazoles and Derivatives. See in Vol 1, A190-R to A191-L

Aminodimethyltriazoles and Derivatives. See in Vol 1, A196-L & R

Aminomethyltriazoles and Derivatives. See in Vol 1, A235-R to A236-L

Aminotriazoles and Derivatives. See in Vol 1, A267-R to A268-L

Amino Triazolecarboxylic Acids and Derivatives. See in Vol 1, A270-L & R

Aminotriazoleione and Derivatives. See in Vol 1, A270-R to A271-L

Aminotriazolopyrimidenes and Derivatives. See in Vol 1, A271-L

Aminotriazolopyrimidinols and Derivatives. See in Vol 1, A271-L & R

Benzeneazo-Carboxy-Phenyl-Triazole and Derivatives. See in Vol 2, B52-R to B53-L

Benzophenyltriazole and Derivatives. See in Vol 2, B78-R to B79-R

Benzotriazole and Derivatives. See in Vol 2, B87-L & R

Benzotriazolol and Derivatives. See in Vol 2, B87-R to B89-L and the following *Addl Compd*:

4-Nitro-1-Hydroxy-5(7)-Methyl-1,2,3-Benzotriazole. $C_7H_6N_4O_3 \cdot H_2O$; mw 211.19; N 26.54%; OB to CO_2 -159.10%; pale yel, hex prisms; mp 205° . Sol in alkalis and carbonates yielding deep orange-red solns. Prepn is by boiling $N_2H_4 \cdot H_2O$ with an ethanolic soln of 2,3,4-trinitrotoluene. The product deflagrates on rapid heating, and detonates violently when heated in a closed tube

Ref: O.L. Brady & J.H. Bowman, JCS **119**, 894-900 (1921) & CA **15**, 2841 (1921)

Benzyltriazole and Derivatives. See in Vol 2, B101-L & R

(3'-Carboxypyrido)-5',6':4,5-Vic (or 1,2,3)-Triazole. See in Vol 2, C66-R

4-Carboxy-a-vic (or 1,2,3)-Triazole. See in Vol 2, C67-L

4,5-Dicyano-1,2,3-Triazole. See in Vol 5, D1219-L

Diphenyltriazole and Derivatives. See in Vol 5, D1485-L to D1487-L

1-Hydroxy-6-Aminobenz-triazole. See in Vol 7, H231-L

3-Imino-5-Phenylimino-1,2,4-Triazoline. See in Vol 7, I34-R to I35-L

2-Methyl-4-Bromo-1,2,3-Triazole (N-Methyl-C-Bromo-Osotriazole).

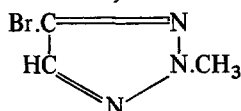

$C_3H_4N_3Br$; mw 162.00; N 25.94%; sticky, odiferous liq; bp $62-65^\circ$ at 22mm. Prepn is by reacting diazomethane with cyanobromide in eth. The triazole explds violently when heated over 260°

Ref: Beil **26**, 12

4-Nitro-1H-1,2,3-Triazole.

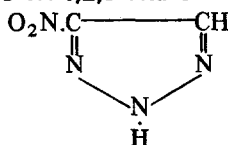

$C_2H_2N_4O_2$; mw 114.08; N 49.12%; OB to CO_2 -42.08%; white crysts; mp $161-62^\circ$; d 1.72g/cc. Sol in hot ethanol

Prepn: A soln of 28.0g of 1-morpholino-2-nitroethene, 35.0g of tosyl azide, and 400ml of abs ethanol is refluxed for 48 hrs. When this soln is chilled, 20-25g of tosyl morpholide crystallizes and is collected by filtration. Evapn of the solvent under reduced pressure leaves a tarry, oily residue. To this residue is added 100ml of chl f, and the resulting combination swirled until the cryst nitrotriazole is liberated from the oily residue. Washing the filtered triazole thoroughly with chl f furnishes 12.4g (60%) of white cryst product

The compd has a 50% pt impact sensy of 25cm (RDX 23cm) using a LASL type 12 app (2.5-kg wt, sample on sandpaper); and is thermally stable to 158° as detd by DTA at a 10° /minute heating rate

Refs: 1) Beil, not found 2) P.N. Newman, JHeterocyclChem **8**, 51 (1971) & CA **74**, 99950 (1971)

[2'-Phenyl-2',1',3'-Triazolo]-4',5':4,5-[1,2,3-Triazole] (2-Phenyl-[triazolo[4',4':4,5-triazole], N-Phenyl-C, C-azimino-osotriazol [Ger] or Phenyl-osotriazolazimid [Ger]).

$(C_6H_5)_2N:N:C:NH$
 $\begin{array}{c} \parallel \\ N=C-N \\ \parallel \end{array}$, $C_8H_6N_6$; mw 189.20; N 44.43%; ndles; mp, decompn at $130-40^\circ$, deflagrates at 147° . V sol in ethanol, eth, chl f and hot bens; v sl sol in w; not sol in ligr. Prepn is by careful warming of 2-phenyl-5-diazo-4-amino-1,2,3-triazole with aq Na acetate and hydrochloric acid

Refs: 1) Beil **26**, 601 2) J. Thiele & K. Schleussner, Ann **295**, 152-53 (1897)

1-Picryl-1H-1,2,3-Triazole.

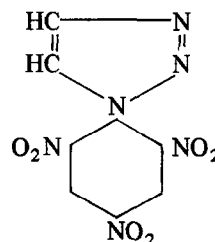

$C_8H_4N_6O_6$; mw 280.18; N 30.00%; OB to CO_2 -68.53%; cryst; mp 224° (decompn); d 1.70g/cc; sol in acet

Prepn: A soln of 4.20g of 1H-1,2,3-triazole, 13.40g of picryl fluoride, and 100ml of dry DMF, protected from atm moisture, is stirred at room temp for 3 days. This soln is then poured with stirring into 2ℓ of w. The pptd product is collected by filtration, washed with w, and dried. The product is then dissolved in a minimal amt of acet (ca 400ml), and to this stirred soln is added 1.5ℓ of w, dropwise at first, until crystn is induced, at which time the flow is increased to a slow, steady stream. The pptd product is again collected by filtration, washed with w, and dried to give a 14.6g (90%) yield

The compd has a 50% pt impact sensy of 11cm (RDX 23cm) using a LASL type 12 app (2.5-kg wt, sample on sandpaper); and is thermally stable to 150° as detd by DTA at a 10°/minute heating rate

Refs: 1) Beil, not found 2) P.N. Newman, *JHeterocyclChem* **8**, 51 (1971) & *CA* **74**, 99950 (1971)

1-Picryl-4-Nitro-1H-1,2,3-Triazole.

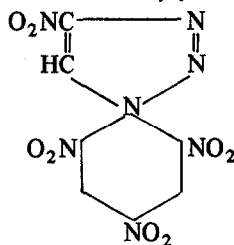

$C_8H_3N_7O_8$; mw 325.18; N 30.16%; OB to CO_2 -46.74%; cryst; mp 233° (explds); d 1.85g/cc; sol in hot methyl ethyl ketone

Prepn. A soln of 8.12g of picryl fluoride, 4.00g of 4-nitro-1H-1,2,3-triazole, and 100ml of dry DMF is stirred at room temp under a dry atm for 24 hrs. The soln is poured with stirring into 1ℓ of w. The crude product is collected by filtration, washed thoroughly with several portions of w, and dried. This product is then dissolved in a minimal amt of hot methyl ethyl ketone. The soln is chilled, and the material that crystd is collected by filtration and washed with cold eth to give 3.28g of product. The vol of the mother liquor is reduced until crystn is induced, and a second product crop of 1.97g is isolated. The total yield is 5.25g (46%)

The compd has a 50% pt impact sensy of 9cm (PETN 11cm) using a LASL type 12 app (2.5-kg wt, sample on sandpaper); and is thermally stable to 165° as detd by DTA at a 5°/

minute heating rate

Refs: 1) Beil, not found 2) P.N. Neuman, *JHeterocyclChem* **8**, 51 (1971) & *CA* **74**, 99950 (1971)

2-Picryl-2H-1,2,3-Triazole.

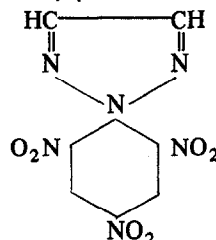

$C_8H_4N_6O_6$; mw 230.18; N 30.00%; OB to CO_2 -68.53%; cryst; mp 211-12°; d 1.69g/cc; sol in hot ethanol-acet

Prepn. To a soln of 3.35g of picryl fluoride, 2.20ml of triethylamine, and 40ml of dry DMSO is added 1.00g of 1H-1,2,3-triazole in one portion. The resulting soln is stirred for 1 hr at room temp protected from atm moisture. The soln is then poured into 800ml of w, the product collected by filtration, washed with w, and dried. The product mixt is recrystd from ethanol-acet, collected by filtration, washed with small portions of cold ethanol, and dried to give a 1.50g (37%) yield

The compd has a 50% pt impact sensy of 200cm (TNT 160cm) using a LASL type 12 app (2.5-kg wt, sample on sandpaper); and is thermally stable to 335° as detd by DTA at a 10°/minute heating rate

Refs: 1) Beil, not found 2) P.N. Neuman, *JHeterocyclChem* **8**, 51 (1971) & *CA* **74**, 99950 (1971)

2-Picryl-4-Nitro-1H-1,2,3-Triazole.

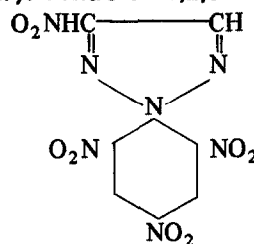

$C_8H_3N_7O_8$; mw 325.18; N 30.16%; OB to CO_2 -46.74%; white crystals; mp 165-66°; d 1.75g/cc; sol in hot ethanol-acet

Prepn. A soln of 1.00g of 2-picryl-2H-1,2,3-triazole, 10ml of 96% sulfuric acid, and 20ml of 100% nitric acid is stirred at 85° for 1 hr. This

soln is then poured over crushed ice, the product collected by filtration, washed with w, and dried. The product is recrystd twice from ethanol-acet to give a 0.96g (83%) yield

The compd has a 50% pt impact sensy of 67cm (RDX 23cm) using a LASL type 12 app (2.5-kg wt, sample on sandpaper); and is thermally stable to 235° as detd by DTA at a 10°/minute heating rate

Refs: 1) Beil, not found 2) P.N. Neuman, JHeterocyclChem 8, 51 (1971) & CA 74, 99950 (1971)

Presented next is a listing of expl 1,2,4-Triazoles, headed by the parent compd, s-Triazole:

1,2,4-Triazole (s-Triazole).

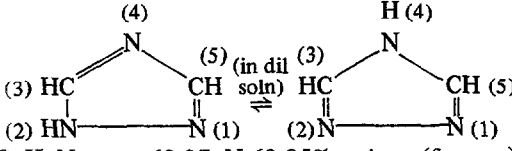

$C_2H_3N_3$; mw 69.07; N 60.85%; prisms (from w), ndles (from ethanol, eth, chl or benz); mp 120–21°; bp 260° (decompn); d 1.132g/cc at 15.3°; RI 1.4854 at 25°. Extremely sol in eth and benz; v sol in ethanol and w. CA Registry No [288-88-0]. Prepn is by heating 1,2,4-triazole carbonic acid-(3) at 120°

Refs: 1) Beil 26, 13 & (7) 2) Merck (1976), 1234 (No 9285)

Addnl Refs: 1) H.H. Strain, "Metallic Salts of . . . 1,2,4-Triazole . . .", JACS 49, 1955–2000 (1949) 2) G. Henning & F. Wolf, "New Synthesis of 1,2,4-Triazoles Via Their Phenyl Derivatives", ZChem 1971, 11 (4), 153 (Ger) & CA 75, 35894 (1971)

Acetamidotriazole and Derivatives. See in Vol 1, A22-R

Allyl Triazole and Derivatives. See in Vol 1, A139-R to A140-L

Aminoethyltriazaoles and Derivatives. See in Vol 1, A207-R to A209-L

Aminoguanazole and Derivatives. See in Vol 1, A209-R to A210-L

Aminohydrazinomercaptotriazoles. See in Vol 1, A216-L & R

Aminomethyltriazaoles and Derivatives. See in Vol 1, A235-R to A237-L

Aminooxytriazaoles and Derivatives. See in Vol 1, A240-L & R

3-Amino-5-Picrylamino-1,2,4-Triazole.

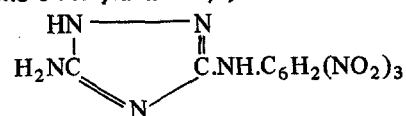

$C_8H_6N_8O_6$; mw 310.22; N 36.13%; OB to CO_2 –67.05%; cryst; mp 275° (decompn); d 1.85g/cc; sol in hot γ -butyrolactone-ethanol mixt

Prepn. A soln of 3,5-diamino-1,2,4-triazole (2.48g, 0.025mole) and picryl chloride (2.48g, 0.01mole) in 50ml of dimethylsulfoxide is heated at 70° for 5 hrs, then poured into 400ml of ice and w. The crude product is collected by filtration and recrystd from γ -butyrolactone-ethanol (treatment with Norite was necessary) to yield 1.86g (60%)

The compd has a 50% pt impact sensy of 230cm (TNT 160cm) using a LASL type 12 app (2.5-kg wt, sample on sandpaper); and exhibits a DTA exotherm at 270°

Refs: 1) Beil, not found 2) M.D. Coburn & T.E. Jackson, JHeterocyclChem 5, 119–203 (1968) & CA 68, 105111 (1968)

Aminotriazoles and Derivatives. See in Vol 1, A268-L to A270-L

Aminotriazolecarboxylic Acids and Derivatives. See in Vol 1, A270-L & R

Aminotriazoleedione and Derivatives. See in Vol 1, A270-R to A271-L

3-Azido-1,2,4-Triazole (3-Azido-sym-Triazole, 3-Azido-2,1,4-triazole or 3-Azido-4,1,2-triazole).

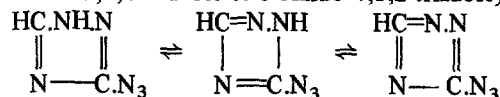

$C_2H_2N_6$; mw 110.08; N 76.35%; yel crystals (from benz); mp 121–22°. V sol in ethanol and w; sl sol in chl and benz. Prepn is by reacting 3-hydrazine-*asym*-triazole (triazylhydrazine) with

Na nitrite and hydrochloric acid at 0°. The compd deflagrates violently with evolution of flame on heating above its mp. It has a ΔH_f° of 104.49 ± 0.56 kcal/mole, and Ref 3 considers it of value in proplnt applications. The compd forms an expl **Silver Salt**, a white ppt which explds on heating

Refs: 1) Beil 26, 21 2) W. Manchot & R. Null, Ann 343, 21 (1905) 3) G.C. Denault et al, "Energy of Combustion and Differential Thermograms of Organic Azides", AFR-SSD-TR-67-128, Contract AF-04(695)-1001, Los Angeles (1967) (AD 657768)

Benzyltriazole and Derivatives. See in Vol 2, B101-L & R

Bis (β -sym or β -1,2,4-) Triazole. See in Vol 2, B159-R to B160-L

Carboxytriazole and Derivatives. See in Vol 2, C66-R to C67-R

Diaminotriazole and Derivatives. See in Vol 5, D1148-L to D1149-R

3,5-Dichlorimino-4,1,2-Triazole (Di-[chlorimino]-3,5-dihydro-3,5-triazole-1,2,4 [Ger]).

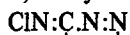

$\text{N}-\text{C.NCl}$, $\text{C}_2\text{HN}_5\text{Cl}_2$; mw 165.98; N 42.20%; yel amorph powder; mp, explds when heated rapidly in a capillary tube to about 135°. Sol in eth; not sol in w. Prepn is by adding an aq soln of guanazole to a bleaching soln contg 7% of "perchloron" (?)

Refs: 1) Beil, not found 2) R. Stolle & W. Dietrich, JPraktChem 139, 197 (1934) & CA 28, 2714 (1934)

4-(2,4-Dinitrobenzyl)-3,5-Dinitrotriazole.

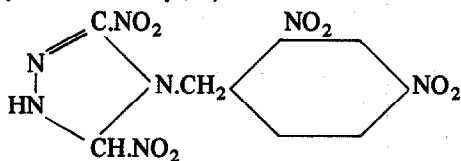

$\text{C}_9\text{H}_5\text{N}_7\text{O}_8$; mw 339.21; N 28.91%; OB to CO_2 -58.96%; cryst; mp 160°; d 1.76g/cc (cryst). Prepn is by reacting 2,4-dinitrobenzyl bromide with the Ag salt of 3,5-dinitro-1,2,4-triazole. The compd has a hot bar ign temp of 322°, approx the impact sensy of Comp B (95cm), and

a 100° thermal stability of 0.06cc of gas/g/48 hrs
Refs: 1) Beil, not found 2) H.P. Burchfield et al, Prog Rept, Contract NOrd 10121, Naugatuck Chem Div, US Rubber Co (Oct-Dec 1949) 3) N.K. Sundholm et al, Ibid (Dec 1949-Feb 1950) 4) W.F. Sager & D.V. Sickman, NAV-ORD 483 (1952)

3,5-Dinitro-1(4)-Methyl-1,2,4-Triazole (N-Methyl-3,5-dinitrotriazole).

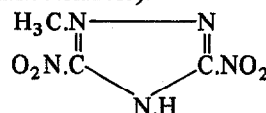

$\text{C}_3\text{H}_4\text{N}_5\text{O}_4$; mw 173.11; N 40.47%; OB to CO_2 -32.35%; white cryst; mp 97.0-97.5°, 98.0-98.5° (sep values). Sol in alcohols, benz and hot isopropanol. Prepn is by reacting Ag dinitrotriazole with methyl iodide by first dissolving Ag dinitrotriazole in acetonitrile, and then adding methyl iodide to the soln. The reaction mixt is then allowed to stand at RT for 12 hrs followed by heating on a steam bath for 10-15 mins. The Ag iodide formed is subsequently filtered off, and the acetonitrile is then distld off. The crystn residue is then recrystd from isopropanol to give a 40% yield

The compd flashes on a hot plate. The triazole has a heat of combustion of 2406cal/g, and a ΔH_c of 1009cal/g

Refs: 1) Beil, not found 2) H.P. Burchfield et al, "Research and Development . . . Explosives . . . Heterocyclic Compounds of Nitrogen . . .", Progress Rept No 3, Naugatuck Chemical Div, US Rubber Co, Contract NOrd 10121 (Feb 1949) 3) Ibid, April 15-June 15, 1949 (1949) 4) N.K. Sundholm et al, Ibid, Aug 15-Oct 15, 1950 (1950)

3,5-Dinitro-1,2,4-Triazole.

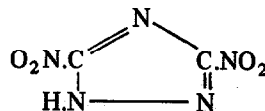

$\text{C}_2\text{HN}_5\text{O}_4$; mw 159.08; N 44.03%; OB to CO_2 -5.03%; yel hydr solid; mp, flashes when dropped on a hot plate. Sol in alcohols, eth and w. Prepn is by the dropwise addn of an excess of nitric acid to a cold soln of guanazole and cupric nitrate in 40% aq Na nitrate. The product is pptd as the Ag salt which is recovered and decompd to the free acid by treatment with

H₂S in eth soln. The Ag sulfide is then filtered off, and the eth soln is evapd under vac leaving the desired product. The triazole has a ΔH_f of 1386cal/g

The dinitro compd forms expl salts such as the: **Mercurous Salt**, C₂N₅O₄Hg; mw 363.66; N 19.26%; OB to CO₂ ±0%; yel, v volatile solid; mp, v violent decompn on heating. Insol in w. Prepn is by dropwise addn of a 0.025M aq soln of Na 3,5-dinitro-1,2,4-triazole to 0.055M nitric acid. The pptd product is then filtered off, washed with distld w, and dried under vac at 50°. The salt has an impact sensy of 34cm (2.5-kg wt) and a 100° vac stab value of 0.12cc of gas/g/48 hrs

Silver Salt, C₂N₅O₄Ag; mw 265.94; N 26.34%; OB to CO₂ ±0%; light yel solid; mp, flashes when dropped on a hot plate; d 2.781g/cc. Insol in w. Prepn is by dropwise addn of a 0.01M aq soln of Ag nitrate to a 0.01M aq soln of Na 3,5-dinitro-1,2,4-triazole. The pptd Ag salt is filtered off and liberally washed with large amts of distld w, and dried under vac at 50°. The triazole salt has an ign temp of 286° (using a hot one mil diam W wire energized by 1 x 10⁶ ergs of electrical energy), and a 100° vac stab value of 2.09cc of gas/g/48 hrs

Refs: 1) Beil, not found 2) H.P. Burchfield et al, "Research and Development in Connection with New High Explosives . . .", Progress Report No 3, Naugatuck Chem Div, US Rubber Co, Contract NOrd 10121 (Feb 1949), III, A-8 2) F. Taylor, "Synthesis and Examination of . . . the Metal Salts of 3,5-Dinitro-1,2,4-Triazole", NAVORD 2307 (1951)

Diphenyltriazole and Derivatives. See in Vol 5, D1485-L to D1487-L

Ethyltriazole and Derivatives. See in Vol 6, E335-R to E336-L

[2'-Hydroxynaphthyl]-1'-Azo-3-[5-Azido-1,2,4-Triazole] (Azido-5-[(oxy)-2-naphthyl-1]-azo-3-triazol-1,2,4 [Ger]).

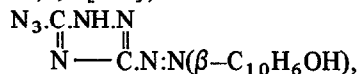

C₁₂H₈N₈O; mw 280.28; N 39.99%; OB to CO₂ -154.13%; orange ndles; mp, decompn at about 195°, puffs off with evolution of flame when

heated above its mp on a spatula. Moderately sol in hot ethanol and concd sulfuric acid; sl sol in cold ethanol; v sl sol in eth; not sol in w. Prepn is by adding an ethanolic soln of β-naphthol to a clear yel-colored soln obtd by treating an intimate mixt of 3-amino-5-hydrazino-1,2,4-triazole hydrochloride and Na nitrite with hydrochloric acid

The compd is considered to be an expl
Refs: 1) Beil 26, 193 & (57) 2) G. Pellizzari, GazzChemItal 24, I, 491 (1894) 3) Ibid, JCS 66 (Abs 1), 518 (1894) 4) K.A. Hofmann & O. Ehrhardt, Ber 45, 2733 (1912) & CA 7, 478 (1913) 5) R. Stolle & K. Krauch, JPrakt-Chem 88, 310-11 (1913) & CA 8, 1091 (1914) 6) R. Stolle & W. Dietrich, Ibid 139, 193-210 (1934) & CA 28, 2714 (1934)

5-Nitro-3-Oxy-1,2,4-Triazole [3-Hydroxy-5-nitro-1,2,4-triazole or 5-Nitro-1,2,4-triazolon-(3) (Ger)]

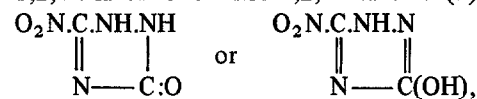

C₂H₂N₄O₃; mw 130.08; N 43.08%; crystals (from ethyl acetate); mp (decompn at about 254° without melting—on rapid heating). V sol in acetic acid, w, methanol and ethanol; less sol in acet and ethyl acetate; sl sol in benz, chl f and eth. Prepn is by treating 3-hydroxy-1,2,4-triazole with fuming nitric acid.. The compd forms expl salts such as the **Silver Salt**; AgC₂HN₄O₃; mw 236.94; bright yel crystals; mp, explds weakly on heating

Refs: 1) Beil 26, 142 2) W. Manchot & R. Noll, Ann 343, 24 (1905)

[3-Nitrosamino-5-Azido]-1,2,4-Triazole [Azido-5-nitrosamino-3-triazol-1,2,4 (Ger)].

N₃ · C · NH · N

$$\begin{array}{c} \parallel \quad \parallel \\ \text{N} - \text{C} \cdot \text{NH} \cdot \text{NO}, \end{array}$$
 C₂H₂N₈O; mw 154.12; N 72.72%; OB to CO₂ -41.53%; ocher-red crystals; mp, deton at ca 134° when heated rapidly on a spatula or in a capillary tube. Insol in ethanol, eth, w and other org solvents. Prepn is by treating an ice-cold aq soln of 3-amino-5-hydrazine-1,2,4-triazole dihydrochloride with an aq soln of Na nitrite

Refs: 1) Beil 26, 193 & (57) 2) R. Stolle & W. Dietrich, JPraktChem 139, 291 (1934) & CA 28, 2714 (1934)

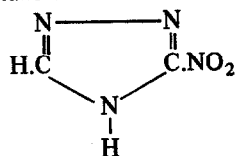
3-Nitrotriazole.

$C_2H_2N_4O_2$; mw 114.08; N 49.12%; OB to CO_2 -42.08%; cryst; mp 214° ; d 1.69g/cc. Prepn is by treating 3-amino-1,2,4-triazole with aq cupric nitrate-Na nitrite soln acidified with acetic acid. The compd has an impact sensy of >160 cm (ERL app, 2.5-kg wt)
 Refs: 1) Beil, not found 2) W.F. Sager & D.V. Sickman, **NAVORD 483** (1952) 3) N.K. Sundholm et al, Prog Rept, Naugatuck Chem Div, US Rubber Co, Contract NOrd 10121 (June-Aug 1950)

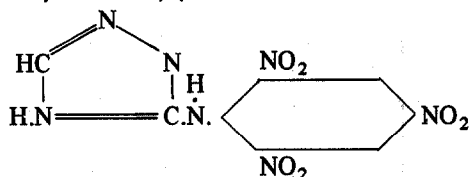
3-(Picrylamino)-1,2,4-Triazole.

$C_8H_5N_7O_6$; mw 295.20; N 33.22%; OB to CO_2 -67.75%; cryst; mp 310° ; d 1.94g/cc. Prepn is by reacting 0.025 mole of 3-amino-1,2,4-triazole with 0.01 mole of picryl chloride in 25ml of $HCON(CH_3)_2$ for 5 hrs at 100° . A 96% yield is obtd

The triazole has a deton vel of 7850m/sec, an impact sensy of >320 cm (using a 2.5-kg wt), and a Chapman-Jouget press of 307kbar at its cryst d

Refs: 1) Beil, not found 2) M.D. Coburn & T.E. Jackson, *JHeterocyclChem* **5**, 201 (1968) & *CA* **68**, 105111 (1968) 3) M.D. Coburn, *USP* 3483211 (1969) & *CA* **72**, 55458 (1970)

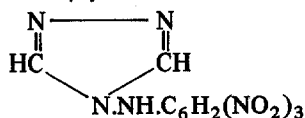
4-Picrylamino-1,2,4-Triazole.

$C_8H_5N_7O_6$; mw 295.20; N 33.22%; OB to CO_2 -67.75%; dk crystals; mp 225° (decompn); d 1.78g/cc; sol in hot acet-ethanol
 Prepn. A soln of 4-amino-1,2,4-triazole (2.12g, 0.025 mole) and picryl chloride (2.48g, 0.01 mole) in 50ml of dimethylsulfoxide is heated at 70° for 5 hrs, then poured into 400ml of ice

and w. The dark solid is collected by filtration, washed with w, and recrystd from acet-ethanol (treatment with Norite is necessary) to give a 1.27g (43%) yield

The compd has a 50 pt impact sensy of 314cm (TNT 160cm) using a LASL type 12 app (2.5-kg wt, sample on sandpaper); and exhibits a DTA exotherm at 220°

Refs: 1) Beil, not found 2) M.D. Coburn & T.E. Jackson, *JHeterocyclChem* **5**, 199-203 (1968) & *CA* **68**, 105111 (1968)

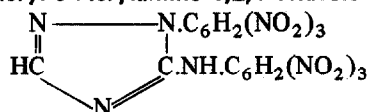
2-Picryl-3-Picrylamino-1,2,4-Triazole.

$C_{14}H_6N_{10}O_{12}$; mw 506.30; N 27.67%; OB to CO_2 -60.04%; cryst; mp 260° (decompn); d 1.80g/cc; sol in hot acet-ethanol mixt

Prepn. Picryl fluoride (2.31g, 0.01 mole) is added to a soln of 3-picrylamino-1,2,4-triazole (2.95g, 0.01 mole) and triethylamine (1.4ml, 0.01 mole) in 50ml of dimethylsulfoxide. The resulting soln is heated at 70° for 5 hrs, then poured into 400ml of ice and w. The mixt is then acidified with concd HCl and the solid collected by filtration, washed with w, and dried. The material is recrystd twice from acet-ethanol to provide 3.78g (75% yield) of the product

The compd has a 50% pt impact sensy of >320 cm (TNT 160cm) using a LASL type 12 app (2.5-kg wt, sample on sandpaper); and exhibits a DTA exotherm at 150°

Refs: 1) Beil, not found 2) M.D. Coburn & T.E. Jackson, *JHeterocyclChem* **5**, 199-203 (1968) & *CA* **68**, 105111 (1968)

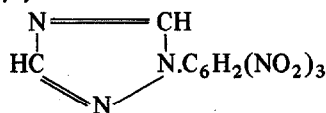
1-Picryl-1,2,4-Triazole.

$C_8H_2N_6O_6$; mw 278.16; N 30.22%; OB to CO_2 -63.27%; cryst; mp 228° (decompn); d 1.70g/cc; sol in hot acet-hexane mixt and DMSO
 Prepn. A soln of 1,2,4-triazole (1.72g, 0.025 mole) and picryl chloride (2.48g, 0.01 mole) in 50ml of γ -butyrolactone is stirred at 25° for 16 hrs. The mixt is diluted with 1l of w, and the pptd solid collected by filtration and dried. The crude product is recrystd from acet-

hexane, yielding 2.50g (88%) of the product

The compd has a 50% pt impact sensy of >320cm (TNT 160cm) using a LASL type 12 app (2.5-kg wt, sample on sandpaper); and exhibits a DTA exotherm at 220°

Refs: 1) Beil, not found 2) M.D. Coburn & T.E. Jackson, *JHeterocyclChem* **5**, 199–203 (1968) & *CA* **68**, 105111 (1968)

[*Pyrido*]-1',2':4,5-[4,1,2-Triazole] [2,3-Diazaindolizin (Ger), also called 1,2,9-Benzoisotriazol (Ger)].

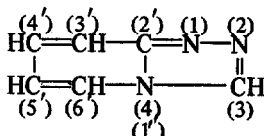

$\text{C}_6\text{H}_5\text{N}_3$; mw 119.14; N 35.28%; white hydr crystals; mp, decompn on being heated. Prepn is by condensation of 2-pyridyl hydrazine with anhydr formic acid

The compd forms expl salts such as the **Silver Salt**; $\text{C}_6\text{H}_5\text{N}_3 + \text{AgNO}_3$; mw 289.02; N 19.39%; OB to CO_2 -63.66%; ndles (from w); mp, decompn at about 298° when heated in a capillary tube. Sol in w. Prepn is by adding an aq soln of Ag nitrate to an aq soln of pyridotriazole

When larger amts of the compd are heated, the material detonates

Refs: 1) Beil **26**, (11) 2) R.G. Fargher & R. Furness, *JCS* **107**, 689, 695–96 (1915) & *CA* **9**, 2890 (1915)

Triazomethane. See in Vol 8, M66-L & R

Tribenzonitrile Oxide. See in Vol 8, N105-L & R

Tribochemistry and the Initiation of Explosions. Tribochemistry is defined as decompn brought about by mechanical means, such as friction, impact, rapid shear or ultrasonic vibration

See under "Detonation, Spot or Hot Spot Initiation of" in Vol 4, D563-R to D569-R; "Hot Spots" in Vol 7, H170-L to H175-R; and "Impact, Initiation of Explosion by" in Vol 7, I43-L to I48-R (*Theoretical Considerations*)
Addnl Ref: F.P. Bowden & A. Yoffe, "Tribo-

chemistry and the Initiation of Explosions", *Research (London)* **1**, 581–88 (1948) & *CA* **43**, 1982 (1949)

2,4,6-Tribromobenzene, 1,3-Dinitro.

$\text{C}_6\text{H}(\text{NO}_2)_2\text{Br}_3$, $\text{C}_6\text{HN}_2\text{O}_4\text{Br}_3$; mw 404.79; N 6.92%; OB to CO_2 -33.6%; colorl prisms or ndles (from ethanol); mp 192°. Sol in benz and C disulfide; sl sol in hot ethanol; v sl sol in cold ethanol; insol in w. Prepn is by heating 25g of sym-tribromobenzene with 100–120g of concd nitric acid (d 1.51g/cc) for 2 hrs. The compd has a 50% pt impact sensy of 27cm or 7.7mkg/cm²

Refs: 1) Beil **5**, 269 2) L. Wohler & O. Wenzelberg, *AngewChem* **46**, 173–76 (1933) & *CA* **27**, 2579 (1933) 3) Blatt, *OSRD* **1085** (1942), 31

2,4,6-Tribromo Benzoic Acid Diazonium Nitrate.

$\text{HO}_2\text{C} \cdot \text{C}_6\text{HBr}_3 \cdot \text{N}(\text{:N}) \cdot \text{O} \cdot \text{NO}_2$, $\text{C}_7\text{H}_2\text{N}_3\text{O}_5\text{Br}_3$; mw 449.82; N 9.34%; OB to CO_2 -35.57%; golden yel ndles; mp, explds when heated. V sol in w; sl sol in dil nitric acid. Prepn is by reacting 2,4,6-tribromo-3-amino benzoic acid with small portions of fuming nitric acid, then cooling the mixt and pptg the product by addn of w
Refs: 1) Beil **16**, 548 2) E.F. Degering (1950), 338

Tributylborane. See in this Vol under "TBB"

Trichloride, Nitrogen. See in Vol 8, N122-R

Trichloromethanephosphonic Acid.

$\text{C}(\text{Cl})_3 \cdot \text{P}(\text{O})(\text{OH})_2 \cdot \text{H}_2\text{O}$, $\text{CH}_4\text{Cl}_3\text{PO}_4$; mw 217.27; ndles; mp 87°. Sol in hot benz. *CA* Registry No [5887-93-4]. Prepn is by heating the diethyl ester of the acid with 15% aq hydrochloric acid at 140–50° for 3–4 hrs followed by vac evapn of the solvent at 50°. The compd forms with Ag nitrate soln a ppt of the **Disilver Salt**, $\text{C}(\text{Cl}_3)\text{P}(\text{O})(\text{OAg})_2$, $\text{CCl}_3\text{PO}_3\text{Ag}_2$; mw 413.06, which explds on heating

Refs: 1) Beil, not found 2) A.Ya Yakubovich & V.A. Ginsburg, "Derivatives of Trichloro-

methanephosphonic Acid", Doklady Akad Nauk SSSR 82, 273-76 (1952) & CA 47, 2685 (1953)

Trichloromethyl Perchlorate. $\text{Cl}_3\text{COCIO}_3$. CCl_4O_4 ; mw 217.82; OB to CO_2 +22.1%; an expl oil; fp, ca -55° ; bp, decomps explosively above RT with evolution of Cl. It is very sens to impact, and detons on contact with org materials, such as stopcock grease. It was prepd by the action of Ag perchlorate on C tetrachloride contg a small amt of H chloride

Refs: 1) Beil 3, {37} 2) L. Birkenbach & J. Goubeau, Ber 64, 218, 227 (1931) & CA 25, 1454 & 3310 (1931)

Trichloronitromethane. See Vol 8, M73-R

1,1,1-Trichloro-3,4,5-Pentanetriol Trinitrate.

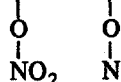
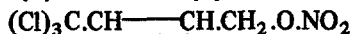

$\text{C}_5\text{H}_6\text{N}_3\text{O}_9\text{Cl}_3$; mw 358.49; N 11.72%; OB to CO_2 -17.85%; yel visc oil. Prepn is by nitration of 1,1,1-trichloro-3,4,5-pentanetriol with mixed acid. The compd burns with a blue flame and no residue; it detonates when dropped on a hot plate

Refs: 1) Beil, not found 2) Anon, "Synthesis of New Explosives and Propellants", Prog Rept 2, US Rubber Co, Contract NOrd 10129 (April 1951)

1,3,5-Trichloro-2,4,6-Trinitrobenzene.

$(\text{Cl})_3\text{C}_6(\text{NO}_2)_3$, $\text{C}_6\text{N}_3\text{O}_6\text{Cl}_3$; mw 316.44; N 13.28%; OB to CO_2 -30.34%; colorl shiny crystals; mp 187° , $195-96^\circ$ (sep values). Sol in hot chlorobenz. Prepn is by treatment of 1,3,5-trichlorobenzene with nitryl tetrasulfide and oleum. The compd is a less powerful and less brisant expl than PA

Refs: 1) Beil, not found 2) Anon, AC 956/Org ex 74 3) Blatt & Whitmore, OSRD 1085 (1942), 123 4) P. Engelbertz, GerP 767510 (1952) & CA 49, 14803 (1955)

Tricinat or Tirzinat. Ger for Normal Lead Styphnate (see Vol 5, D1278-L ff). Also called Bleistypnate or Bleinitroresorcinat

Tricycloacetone Peroxide. See Vol 1, A42-L to A45-L

Tridecane, 2,2,4,7,7,10,12,12-Octanitro-4,10-Diaza-

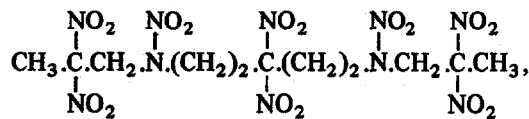

$\text{C}_{11}\text{H}_{18}\text{N}_{10}\text{O}_{16}$; mw 546.39; N 25.64%; OB to CO_2 -43.92%; mp $206-08^\circ$; d 1.7g/cc. Prepn is by nitration of the bis secondary amine obtd from reacting 2,2-dinitropropanol with 1,5-diamino-3,3-dinitropentane (2). The compd has a hot bar ign temp of 244° and a 50% pt impact sensy about that of Pentolite

Refs: 1) Beil, not found 2) L.T. Carleton & M.B. Frankel, "Explosives Research", Rept 711, Aerojet General Corp, Azusa, Contract N7 onr 46208 (1953) 3) D.V. Sickman & W.F. Sager, NAVORD 486 (1954)

Trident. US underwater-to-surface ballistic missile, under development. The Trident, formerly called ULMS (Undersea Long-range Missile System), has been under study for some years as a third-generation follow-on to Polaris (qv) and Poseidon (qv). Work has started on the Trident I missile, which will have a range of 7400km and will carry MIRV (multiple independently-targeted) warheads. The missile range will make the carrier-submarines much more difficult to locate and track, by extending immensely the area of ocean in which they can patrol and still be within range of their designated targets

Trident will be installed in 10 of the present Poseidon submarines and in the new 24-tube Trident submarines, the first of which is to be operational by April 1979. Altogether, 10 Trident submarines will be built

Development is continuing on a Trident II missile of much improved accuracy, and on the Mk 500 Evader maneuvering re-entry vehicle (MARV) to elude advanced Soviet ABMs
Refs: 1) M.J.H. Taylor & J.W.R. Taylor, "Missiles of the World", Charles Scribner's Sons, NY (1976), 154 2) R.T. Pretty, Ed, "Jane's Weapon Systems-1977", Franklin Watts, NY (1976), 26 & 282

Tridites. Expl mixts contg Picric Acid (PA) and Dinitrophenol (DNPh). During WWII, the Brit used a mixt contg PA 70 and DNPh 30%, termed **Shellite** (qv in this Vol), in shells and armor-piercing bombs. A 60/40 mixt, designated **MBT**, was used by Italy for loading shell; and the same mixt, designated **DD**, was used by the Fr for loading shell and bombs. These mixts were suitable for melt loading at temps below 100°, and therefore represented an improvement over the melt loading of PA (mp 122°; qv in Vol 8, P285-R to P295-L). Tridite is slightly inferior to PA as an expl, and DNPh is somewhat objectionable because of toxicity

Mixts ranging in PA content from 60 to 90%, and DNPh content from 40 to 10% were evaluated: color, light cream to yel; loading d (cast), ca 1.62g/cc; mp, 80 to 90°; ballistic strength, 90 to 100% TNT; brisance (sand test), 36 to 43g; vel of deton, 6300 to 7000m/sec; expln temp, 300–15°; impact sensy (PicArns app, 2-kg wt), 12.5 to 14"; rifle bullet sensy, 0 to 20% detonations with 30-cal bullets fired from 90'; stability, compatibility with metals, solubility in solvents, toxicity — same as PA

Refs: 1) C.J. Bain, "Use of Tridite as a Bursting Charge for Nose Fuzed Shell", **PATR 546** (1934) (AD 896158). [Effect of magazine storage and 50° storage on Tridite loaded shell] 2) A.J. Phillips, "Modification of Tridite to Reduce Toxicity", **PATR 926** (1938) (AD 495118) [A mixt of PA 88 and Mononitronaphthalene 12% is recommended] 3) C.S. Davis, "Determine Suitability of Tridite Charges for Chemical Shell Burster Tubes", **PATR 906** (1938) (AD 495181) [Tridite cast in a bakelite tube would give the same fragmentation of the 155-mm T6 shell as the Tetryl burster previously used] 4) C.J. Bain, "Study of Picric Acid-Mononitronaphthalene Mixture as a Shell Filler", **PATR 976** (1939) (AD 896680) [Alphanitronaphthalene, substituted for the Dinitrophenol in Tridite, gives a mixt which can be satisfactorily cast in 3" AA and 155-mm shell] 5) Anon, "Allied and Enemy Explosives", **APG, Md** (1946), 99–100 6) Anon, "Military Explosives", **TM 9-1910** (1955), 214

Triethanolamine and Derivative

Triethanolamine (2,2',2''-Nitrilotriethanol, Tri-

hydroxytriethylamine, Tris (hydroxyethyl) amine or Triethylolamine). $N(CH_2.CH_2.OH)_3$, $C_6H_{15}NO_3$; mw 149.19; N 9.39%; v hydr visc liq, sl ammoniacal odor, turns brn on exposure to air and light; fr pt 21.57°; bp 335.4°; d 1.1242g/cc at 20/4°; RI 1.4852. Sol in benz; sl sol in eth and C tetrachloride; v sl sol in n-heptane. Prepn is by ammonolysis of ethylene oxide. The oleate has been incorporated into Dynamites as a plasticizer added to the NG by Glogau (Ref 2)

Refs: 1) Beil 4, 285 & [729] 2) R.G. Glogau, **USP 2676878** (1954) & **CA 48**, 13223 (1954) 3) Merck (1976), 1241 (No 9347)

Triethanolamine Tetranitrate. (Triethanolamine trinitric ester nitrate, Tris (β -nitroxyethyl)-amine nitrate or Trinitroxytriethaneamine nitrate). $N(CH_2.CH_2.ONO_2)_3.HNO_3$ or $[HN(CH_2.CH_2.ONO_2)_3]NO_3$, $C_6H_{13}N_5O_{12}$; mw 347.24; N 20.17%; OB to CO_2 -29.95%; mp 74° (decompn), 62.7°, 62° (sep values). Hydrolyzed by w. Sol in hot ethanol; insol in eth. Prepn is by nitration of triethanolamine nitrate with 97% nitric acid at -5°, removing the excess nitric acid *in vacuo*, pptg the product at -10° with eth, and recrystn from ethanol

The amine has a defon temp of 115°, sand test (brisance) of 44g (TNT 48), an impact sensy of 15cm (2-kg wt), and a thermal stab of decompn at 50° in 44 hrs

Refs: 1) Beil 4, 285 & [729] 2) Blatt & Whitmore, **OSRD 1085** (1942), 94 3) Anon, **BritP 350293** (1929) & **CA 26**, 5423 (1932) 4) J. Barbière, **BullFr 11**, 470–80 (1944) & **CA 40**, 2110 (1946) 5) L. Médard, **MP 36**, 93 (1954) & **CA 50**, 6795 (1956) 6) Urbański 2 (1965), 473

Triethyl Aluminum. See in this Vol under "TEA"

Triethylaluminum Etherate.

$4Al(C_2H_5)_3.3(C_2H_5)_2O$, $C_{36}H_{90}O_3Al_4$; mw 679.0; colorl liq, eth odor; OB to CO_2 -268.63%; bp 112° at 16mm. Prepn is by reacting Electron metal turnings (Al 15.1, Mg 84.5 and SiO 0.4%), covered with eth, with ethyl bromide added dropwise under reflux. The product is distilled off under N_2 into an ice-cooled flask. According

to Sax (Ref 3), the etherate explds on contact with moisture, evolving ethane

Refs: 1) Beil, not found 2) G. Brauer, Ed, "Handbook of Preparative Inorganic Chemistry", Vol 1, 2nd Ed, Academic Press, NY (1963), 811 3) Sax (1968), 1186

Triethylamine Perchlorate. $\text{Et}_3\text{N.HClO}_4$; $\text{C}_6\text{H}_{16}\text{ClNO}_4$; mw 201.65; OB to CO_2 -127.0%; cryst solid; mp 168-71°. Its impact sensy was found to be above 120 inches using the PicArsn machine with a 2-kg wt (insens). A stoichiometric soln in 100% nitric ac (fp -65°; storage stab at 200°F, 60 hours; I_{sp} at 20 atm, 218.1 secs) has been patented as a monopropant
Refs: 1) Beil, not found 2) R.C. Doss, USP 3031838 (1962) & CA 57, 7508 (1962)

Triethylammonium Nitrate (Ethanamine, N,N-diethyl nitrate). $(\text{C}_2\text{H}_5)_3\text{N.HNO}_3$, $\text{C}_6\text{H}_{16}\text{N}_2\text{O}_3$; mw 164.24; N 4.88%; OB to CO_2 -68.17%; colorl cryst; mp 99-100°, 112° (sep values); d 1.0890g/cc at 25/4°. Sol in eth, the ethyl ester of formic acid, methylene chloride and w. CA Registry No [27096-31-7]. Prepn is by solvolysis of triethylammonium chloride in dinitrogen tetroxide at reduced press and below -50°. Caution should be exercised in the next step of the prepn, which is eth extraction of the product to isolate *only* the product nitrate salt. If the tetroxide is allowed to co-exist in the crude product, it is reported in Ref 2 that a ratio of 2:1 triethylammonium nitrate to dinitrogen tetroxide occurs at room temp (because of the decompn of tetroxide in excess of this ratio) which will violently self-detonate. It is also pointed out that the eth used as the product extractant will co-extract these compds in the undesirable ratio of 2:1. Ref 2 further advises that in order to safely recover the desired product from eth, the following procedure should be followed; viz, the addn of eth at -50° will produce a pale yel expl solid (detd as $\text{N}_2\text{O}_4 \cdot 2(\text{C}_2\text{H}_5)_3\text{NH.NO}_3$) which should be rapidly filtered off from the eth by passage thru a glass tube contg a sintered glass plate. The recovered solid is then washed three times with eth at -50°, followed by the use of a rapid stream of dry air passed thru the mat of crystals while allow-

ing the temp to rise v slowly (over a period of one hour) to room temp. As the temp gradually increases, eth and N_2O_4 are carried off leaving only the pure colorl product

Refs: 1) Beil 4, 99, (349) & [595] 2) C.C. Addison & N. Hodge, "The Explosive Decomposition of Triethylammonium Nitrate-Dinitrogen Tetroxide Mixtures", Chem&Ind 1953, 1315 & CA 48, 3691 (1954)

Triethylborane. See in this Vol under "TEB"

Triethylenegcoldinitrate. See under "TEGDN" in this Vol

Triethylenetetramine. See under "TETA" in this Vol

Triethyl Lead Azide. $(\text{C}_2\text{H}_5)_3\text{Pb.N}_3$, $\text{C}_6\text{H}_{15}\text{N}_3\text{Pb}$; mw 336.44; N 12.94%; cryst; mp, melts and then detonates mildly when placed on a hot plate. Prepn is by treating triethyl Pb acetate with Na azide
Ref: Beil 4, [1021]

Triethyllead-Mono-Ethyl-Oxalate. $(\text{C}_2\text{H}_5)_3\text{Pb.O.O.C.C.O.O.C}_2\text{H}_5$, $\text{C}_{10}\text{H}_{20}\text{O}_4\text{Pb}$; mw 411.50; OB to CO_2 -101.09%; cryst; mp 55° (decompn at 140°). Prepn is by refluxing triethyl Pb chloride with K monoethyl oxalate in ethanol for 1.25 hrs. The compd explds when heated rapidly
Refs: 1) Beil, not found 2) R. Heap & B.C. Saunders, JCS 1949, 2983-88 & CA 44, 3880 (1950)

Trifluoro Ethyl Tetryl. See under "TFEt Tetryl" in this Vol

Trifluoronitromethane. See Vol 8, M72-R

3,3,3-Trifluoro-1,2-Propane Dinitrate (or 3,3,3-Trifluoro-1,2-propyl dinitrate).

$\text{CF}_3\text{CH}_2\text{CH}_2\text{OONO}_2$, $\text{C}_3\text{H}_3\text{N}_2\text{O}_6\text{F}_3$;

OONO_2

mw 220.08; N 12.73%; OB to CO_2 -10.91%; colorl liq; bp 165-70° corrected to 760mm, 38° at 5mm; d 1.6067g/cc; RI 1.3890. Sol in eth and C tetrachloride; not sol in C disulfide and w. Prepn is by dropwise addn of 3,3,3-trifluoro-1,2-propanediol to a mixt of B trifluoride-concd (d 1.5g/cc) nitric acid at -5° with stirring. When the addn of the diol is completed, the reaction mixt is stirred for another 45 mins and then poured into cold w. The crude product is extracted with eth, with subsequent eth evapn using N_2 . Finally, the eth concentrate is subjected to vac distln in a semi-micro app with the pure product coming off at 37-38° (5mm). The yield is 77%

The compd has a brisance of 5.4g of sand crushed (TNT 48.0), an expln temp of 275° in 4 secs, impact sensy of 18" using a 2-kg wt and 34" using a 500g wt; and a thermal stab at 100° of evapn with no sign of decompn

Refs: 1) Beil, not found 2) J.P. Picard et al, "Investigation of Some New Fluoro-Nitroxy Compounds", FRL Proplnt Section Rept 9 (1960) 3) Y.P. Carignan, "Study of the Nitration of 3,3,3-Trifluoro-1,2-Epoxypropane", PATR 3055 (1963)

Trifulmin. See Vol 8, N105-R

Triginato. Spanish name for Lead Styphnate
Ref: Vivas, Feigenspan & Ladreda, Vol 2 (1946), 324

Triglycolamidic Triazide (or Nitrilotriacetic Azide). $\text{N}(\text{CH}_2\text{CON}_3)_3$, $\text{C}_6\text{H}_6\text{N}_{10}\text{O}_3$; mw 266.26; N 52.63%; OB to CO_2 -72.11%; lflts (from eth); mp, explds violently when heated. Sol in hot eth. Prepn is by treating nitrilotriacetic hydrazide hydrochloride with Na nitrite in w and eth
Refs: 1) Beil 4, (483) 2) T. Curtius, JPrakt-Chem [2] 96, 234 (1917) & CA 12, 2318 (1918)

Trihydrazine Nickel (II) Nitrate. See in Vol 8, N26-R under "Nickel-Hydrazine Nitrate Com-

plex" and the following *Addnl Ref*: H.E. Ellern & D.E. Olander, "Spontaneous Explosion of a Normally Stable Complex Salt", JChemEduc 32, 24 (1955) & CA 49, 6607 (1955) [The authors report that the salt exploded for no apparent reason after about 10 mins exposure to the atm subsequent to prepn by the method of Medard and Barlot (Ref of Vol 8 article). They caution that salts such as this should be treated as initiating expls until proved otherwise]

4,5,2'-Trihydroxy-2-Methyl-Anthraquinone, 1,3,6,8-Tetranitro. $(\text{O})_2\text{C}_{15}\text{H}_2(\text{NO}_2)_4(\text{OH})_3$, $\text{C}_{15}\text{H}_6\text{N}_4\text{O}_{13}$; mw 450.25; N 12.45%; OB to CO_2 -71.07%; orange crystn powder (from ethanol); mp, explds mildly when heated. V sol in aq ammonia and ethanol; sol in hot w; sl sol in cold w and acids. Prepn is by nitration of 4,5,2'-trihydroxy-2-methyl anthraquinone with concd nitric acid at 90-100° (steam bath), and then drowning the reaction and pptg the crude product by pouring into ice-w. The crude product is then w-washed and recrystd from ethanol. The compd forms expl salts such as the **Silver Salt**; $\text{Ag}_2\text{C}_{15}\text{H}_4\text{N}_4\text{O}_{13}$; mw 663.97; N 8.49%; OB to CO_2 -45.79%; dk red powder; mp, explds on heating; insol in w
Ref: Beil 8, 525

Triisobutylborane (or Triisobutylborine). $[(\text{CH}_3)_2\text{CH.CH}_2]_3\text{B}$; mw 182.20; pyrophoric liq; bp 188°; d 0.7380g/cc at 25/4°; RI 1.4188 at 22.8°. Prepn is by reacting an ethereal soln of B fluoride with isobutylMgchloride. Triisobutylborane self-ignites in air, burning with a brilliant green flame
Ref: Beil 4, [1022]

Trilita (or Trilites). Spanish for Trinitrotoluene (TNT). See under "Spanish Explosives and Ammunition" in this Vol

p-N,N-Trilithioaniline. See Vol 1, A407-L

Trimeric Acetone Peroxide. See Vol 1, A42-R to A45-L

Trimethyl Aluminum. See under "TMA" in this volume

Trimethylamine. See under "TMA" in this Vol

Trimethylamine Oxide Perchlorate.

$\text{Me}_3\text{NO} \cdot \text{HClO}_4$; $\text{C}_3\text{H}_{10}\text{ClNO}_5$; mw 175.57; OB to CO_2 -54.7%; cubic crystals; explds on heating or with a hammer blow. It was prepd by evapn of a soln of trimethylamine oxide in aq perchloric ac in a vacuum over sulfuric ac, until crystals appeared

Refs: 1) Beil 4, (325) 2) K.A. Hofmann et al, Ber 43, 2626 (1910)

Trimethylammonium Nitrate [Trimethylamine nitrate, trimethylamminitrat or Tri-salz (Ger)]. $(\text{H}_3\text{C})_3\text{N} \cdot \text{HNO}_3$, $\text{C}_3\text{H}_{10}\text{N}_2\text{O}_3$; mw 122.14; N 22.94%; OB to CO_2 -104.79%; colorl crystals (ndles and prisms); mp 153° . V sl sol in cold ethanol. Prepn is by addn of nitric acid in aq soln followed by pptn in the cold, filtration and recrystn from ethanol. The salt has a heat of expln of 834kcal/kg and a vol of deton gases of 1102l/kg. Its energy of formation is -562 kcal/kg, and enthalpy of formation is -598 kcal/kg. The salt is not stable when stored above 150° and may become auto-catalytically accelerated into an expln because of the progressive prodn of nitric oxide from the liberated nitric acid (Ref 2)

Mayer (Ref 3) reports that the compd has been proposed as a component of castable charges and of expl slurries

Refs: 1) Beil 4, 47 2) H. Walter et al, "German Developments in High Explosives", FIAT Final Rept 1035 (1947), 7 & 8 3) R. Meyer, "Explosives", Verlag Chemie, NY (1977), 299

Trimethylammonium Perchlorate (Trimethylamine perchlorate). $(\text{CH}_3)_3\text{N} \cdot \text{HClO}_4$, $\text{C}_3\text{H}_{10}\text{ClNO}_4$; mw 159.59; N 8.78%; OB to CO_2 -70.18%; pyrimidal crystals (Ref 2); mp 305° (decompn). CA Registry No [15576-35-9]. Sol in hot and insol in cold ethanol and w. Prepn is by reacting an aq soln of trimethylamine with 70% perchloric acid, followed by evapn of excess w, then

cooling the concd soln to produce crystals of the crude product. After filtering off the excess w, the crystals are washed with cold w and ethanol. The crude product is recrystd from hot aq ethanol with subsequent cold ethanol washing and vac drying

The perchlorate has an activation energy of 16.6kcal/mole; decompn temp of 305° (thermo-gravimetric anal), 320° (DTA); expln temp delay times of 330° (57.0), 345° (43.0), 360° (26.2) and 380° (20.4 secs); and an impact sensy of 25cm (Ref 5). Its thermal decompn was studied with the aid of mass spec by workers at NOSIH. They found that betw 250° and 320° it dissociates into trimethylamine and perchloric ac, which then react in the vapor phase to form H chloride, N dioxide, w, O, and some nitrous oxide (Ref 3)

Samples of the salt were packed into tubes, ignited, and the change of burning rate with press measured. The following results were obtained:

Press in Atm	Equation for the Change of Burning Rate with Press
1.5-6	$u = 0.15p^{0.93}$ cm/sec
6-290	failed to burn
290-400	$u = 2.7 \times 10^{-17} p^{6.66}$ (Ref 4)

Refs: 1) Beil 4, (324) 2) K.A. Hofmann et al, Ber 43, 2626 (1910) 3) W.A. Guillory & M. King, JPhysChem 73, 4367 (1969) 4) A.E. Fogel'zang et al, FizGoreniyaVzryva 8, 257 (1972) & CA 78, 45833 (1973) 5) P.R. Nambiar et al, "Explosive Sensitivity of Methyl Ammonium Perchlorates", JThermAnal 8, 15-26 (1975) & CA 84, 46824 (1976)

Trimethyl-o-anisidinium Perchlorate.

$o\text{-MeOC}_6\text{H}_4\text{N}^+\text{Me}_3 \cdot \text{ClO}_4$, $\text{C}_{10}\text{H}_{16}\text{ClNO}_5$; mw 265.70; OB to CO_2 -138.5%; cryst solid; mp 65° , explds on further heating. It was prepd by treating a concd soln of the chloride with a concd soln of Na perchlorate, the ppt filtered, washed with cold w, and dried

Refs: 1) Beil 13, 763 2) A. Zaki & H. Fahim, JCS 1942, 270

Trimethylbenzene and Derivatives. See under "Mesitylene and Derivatives" in Vol 8, M61-R to M63-L

Trimethylene-1,3-Dinitramine (1,3-Dinitraminopropane, N,N'-Dinitrotrimethylenediamine). $O_2N.NH.CH_2.CH_2.CH_2.NH.NO_2$, $C_3H_8N_4O_4$; mw 164.15; N 34.14%; OB to CO_2 -58.48%; prisms (from w); mp 67° . V sol in ethanol and w; sl sol in chl f and eth. Prepn is from N,N'-dinitro-N,N'-dicarbo-methoxytrimethylene diamine

Power by BalMort is 118% TNT. See also in Vol 5, D1143-L under "1,3-Diaminopropane"
Refs: 1) Beil 4, 573 2) Franchimont & Klobbie, Rec 7, 352 (1887)

Trimethylene-1,2-Dinitrate. See under "1,2-Dinitraminopropane" in Vol 5, D1142-R

2,2-Dinitro-Trimethylene-Dinitrate.

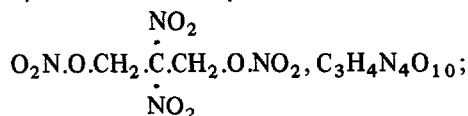

mw 256.11; N 21.88%; OB to CO_2 12.49%; mobile oil, fr pt $<-65^\circ$; d 1.571g/cc at 31.5° ; RI 1.4675 at 20° . Sol in eth; insol in w. Prepn is by nitration of 2,2-dinitropropanediol with concd (sp grav 1.5) nitric acid at 0° . The inventor terms this compd a powerful expl
Refs: 1) Beil, not found 2) H. Plant, USP 2978484 (1961) & CA 55, 15934 (1961)

Trimethyleneglycol Dinitrate. See in Vol 8, P399-R to P400-L

Trimethylene Glycol Diperchlorate.

$O_3Cl.O.CH_2.CH_2.CH_2.O.ClO_3$, $C_3H_6O_8Cl_2$; mw 290.99; OB to CO_2 -6.64%. The salt has been found to be extremely sensitive to friction and impact. It has a Pb block expansion of 113% PA
Refs: 1) Beil, not found 2) Blatt, OSRD 2014 (1944)

Trimethylene Peroxide Azine (Methyleneamino-dihydro-1,2,4-dioxazole or 4-Methyleneamino-1,2,4-dioxazolidine).

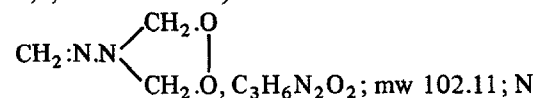

27.44%; OB to CO_2 -109.69%; odorless, sl yel cryst; mp, explds without melting. Sol in mineral acids; v sl sol in chl f , MNB and benz; v v sl sol in ethanol, eth, ligr and w. Prepn is by the interaction of formaldehyde and hydrazine sulfate with 3% aq hydrogen peroxide at $40-50^\circ$. A 56% yield based on the wt of hydrazine sulfate reacted is reported in Ref 2. The compd decomps on long exposure to air. When rapidly heated in a closed tube, the azine detonates, producing a bright light; when heated in the open, it deflagrates when brought in contact with a flame. It is only sl sensitive to impact and requires a strong hammer blow to detonate it. Concd sulfuric acid causes it to expld with the production of flame

Refs: 1) Beil 27, [523] 2) F.C. vonGirselwald & H. Siegens, Ber 54, 493 (1921) & CA 15, 2416 (1921) 3) J.F. Walker, "Formaldehyde", Reinhold, NY (1944), 129

Trimethylene-1,2,3-Triketo-Azide.

$$HC.CO.N_3$$

$$HC(CO.N_3).HC(CO.N_3), C_6H_3N_9O_3; \text{mw } 249.18; N 50.80%; OB to CO_2 -86.68%; \text{oily liq; bp } 90-100^\circ (\text{decompn}). \text{Sol in eth and abs ethanol. Prepn is by diazotization of trans-1,2,3-cyclopropane triketohydrazide using excess HCl. The azide is a v brisant expl sensitive to the slightest mechanical action or exposure to a preheated hot plate}$$

Refs: 1) Beil, not found 2) W. Perkin & H. Ing, JCS 125, 1814-30 (1920) & CA 19, 246 (1925)

1,2,3-Trimethyl-2-Nitro-Propanediol-1,3-Dinitrate.

$$CH_3.CH.O.NO_2$$

$$CH_3.\overset{\cdot}{C}.NO_2$$

$CH_3.CH.O.NO_2, C_6H_{11}N_3O_8$; mw 254.20; N 16.53%; OB to CO_2 -59.80%; oil substance. Prepn is by nitration of trimethylnitropropanediol with mixed acid. It is an expl less powerful than either nitroisobutylglycerol dinitrate or nitroisoamylglycol dinitrate
Refs: 1) Beil, not found 2) F.A. Bergeim, USP 1691955 (1928) & CA 23, 708 (1929)

1,1,1-Trimethylolbutane Trinitrate.

$\text{CH}_3\text{.CH}_2\text{.CH}_2\text{.C}(\text{CH}_2\text{.O.NO}_2)_3$, $\text{C}_7\text{H}_{13}\text{N}_3\text{O}_9$; mw 283.23; N 14.84%; OB to CO_2 -64.96%; solid; mp 69.3–69.7°. Prepn is by nitration of 1,1,1-trimethylolbutane using 98.5% nitric acid. The yield is 85%. The trinitrate has a 50% pt impact sensy of 62cm using a Bruceton No 5 app, power by BalMort of 117% TNT, and a thermal stability at 135° of 40 mins
Refs: 1) Beil, not found 2) Blatt, OSRD 2014 (1944)

1,1,1-Trimethylolethane Trinitrate. See under "Metriol Trinitrate" in Vol 8, M120-R to M121-R

Trimethylolmethane and Derivatives. See in Vol 8, M116-R to M117-R

Trimethylolnitromethane. See under "Trimethylolmethane" in Vol 2, B371-R

Trimethylolnitromethane Trinitrate. See in Vol 2, B371-R to B372-R, and under "Nitroisobutylglycerol Trinitrate" in Vol 8, N112-R to N113-R

1,1,1-Trimethylolpropane Trinitrate (Ethriol Trinitrate, Trimethylolethylmethane Trinitrate, EMMET).

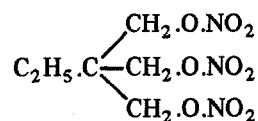

$\text{C}_6\text{H}_{11}\text{N}_3\text{O}_9$; mw 269.4; N 15.62%; OB to CO_2 -50.5%; colorl crystals; mp 51.6°; d 1.5g/cc; sol in hot ethanol

Prepn is by nitrating trimethyl-propane (obtained by condensing formaldehyde with butyraldehyde in the presence of lime) with a mixt of nitric and sulfuric acids

The compd exhibits a deton vel of 6440m/s, an energy of formation of -401kcal/kg, an enthalpy of formation of -426kcal/kg, a heat of expln of 1236kcal/kg, power by Pb block test of 415cc/10g sample, and a volume of detonation gases of 822l/kg (Ref 5)

Ref 2 gives the following data:

Bal Mortar. 127% TNT

Heat of Combustion. 825.5cal/mole

Impact Sensitivity. FI 121% PA; comparable with TNT (separate refs)

Pb Block Expansion. 121% PA

Rifle Bullet Impact. Eight trials in 1" pipe nipples gave four high order detonations and four partial detonations. Eight trials in welded boxes, 2"x1"x1½" sheet metal with a 3/8" steel back and top, gave eight partial or incipient detonations. In both of these tests TNT consistently gave no explns

Stability. Deflagrates at 240°, no expln to 360°; explds in one second in metal container at 255° (separate refs)

Surveillance. No decrease in stability after three months at 50°

Thermal Stability. At 100°, not acid, no explns in 300 minutes. At 135°, acid in 50 minutes, no expln in 300 minutes

Vacuum Stability, 100°. 10cc gas/5g sample in 48 hrs; 6.17cc gas/5g sample in 48 hrs (separate refs). See also under "Ethyltrimethylolmethane Trinitrate" in Vol 6, E337-L

Refs: 1) Beil, not found 2) Blatt, OSRD 2914 (1944) 3) G. Bourgol, MP 36, 79–85 (1954) 4) W. Hensinger, FrP 1103113 (1955), MP 38, 465–66 (1956) & CA 53, 6087 (1959) 5) R. Meyer, "Explosives", Verlag Chemie, NY (1977), 101

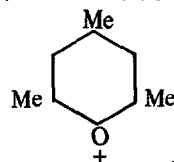
2,4,6-Trimethylpyrylium Perchlorate.

+ ClO_4^- , $\text{C}_8\text{H}_{11}\text{ClO}_5$; mw 222.63; OB to CO_2 -118.6%; colorl crystals from hot w; mp 245–47° with decompn; CA Registry No [940-93-2]. It is prepd by the reaction between tert-Bu alc, Ac_2O , and perchloric ac; or between 4-me-3-butene-2-one, Ac_2O , and perchloric ac (Ref 2). *Caution!* The salt is expl and the prepn should be carried out behind a good shield. Its impact sensy is similar to RDX. The dry crystals are especially sensitive and they should not be crushed, rubbed, or pushed thru a narrow opening. The compd is a useful reagent for the prepn of azulenes, pyridines, and other

cyclic compds

Refs: 1) Beil—not found 2) H.E. Baumgarten, ed, "Organic Syntheses, Collective Vol 5", J. Wiley & Sons, NY (1973), 1106

Trimethylsulfine Chlorate. $S(CH_3)_3ClO_3$; $C_3H_9ClO_3S$; mw 160.63; OB to CO_2 -74.71%; hydr crystals liquefying on exposure to air; mp, explds at 170° . V sol in cold w. CA Registry Nos [3110-90-6, or 33110-92-8, or 40250-76-8]. Prepn is by the double decompn between Ag chlorate and trimethylsulfine iodide, and the evapn of the resulting soln using a w bath. The salt explds with great rapidity and sharpness when a flame is presented to it.

Refs: 1) Beil, not found 2) R.L. Datta & J.K. Choudhury, JACS **38**, 1079-86 (1916) & CA **10**, 1749 (1916)

Trimethyltoluidinium Perchlorate (or Tolytrimethylammonium Perchlorate). $C_{10}H_{16}ClNO_4$; mw 249.70; OB to CO_2 -153.8%. Three isomers of trimethyltoluidinium perchlorate were prepd by treatment of the iodide with Ag perchlorate in aq soln, the Ag iodide filtered off, the filtrate evapd until crystals formed, and the crystals recrystd from acet/eth (Ref 7). The salts all expld when heated above their mp's (Ref 5):

Trimethyl-o-toluidinium Perchlorate. o-MeC₆H₄N⁺Me₃.ClO₄⁻; cryst solid; mp 198-99° (Refs 1 & 5)

Trimethyl-m-toluidinium Perchlorate. m-MeC₆H₄N⁺Me₃.ClO₄⁻; cryst solid; mp 124°; (Refs 2 & 6)

Trimethyl-p-toluidinium Perchlorate. p-MeC₆H₄N⁺Me₃.ClO₄⁻; cryst solid; mp 192°; expln temp 310° (Refs 3 & 4); CA Registry No [19016-79-6]

Refs: 1) Beil **12**, {1843} 2) Beil **12**, {1954} 3) Beil **12**, (413) & {2027} 4) R.L. Datta & N.R. Chatterjee, JCS **115**, 1009 (1919) 5) A. Zaki & H. Fahim, JCS **1942**, 270 6) J.T. Dension & J.B. Ramsey, JACS **77**, 2616 (1955) 7) J.H.P. Utley & T.A. Vaughan, JCS **1968B**, 198

Trimolecular Acetone Peroxide. See Vol 1, A42-R to A45-L

Trimonite. A castable expl mixt of Picric Acid (PA) 88-90 and α -Mononitronaphthalene 10-12%, developed by the Brit during WWII as an improvement on Tridite (qv in this Vol), to avoid the undesirable toxicity characteristics of Dinitrophenol. Both mixts are suitable for melt loading below 100° and therefore represent an improvement over melting PA alone (mp 122°)

Because of the low eutectic temp of Trimonite ($46.7-49^\circ$), it is subject to exudation when stored at elevated temps. It is less sensitive to initiation than PA, and is of interest only as an emergency substitute for TNT compns

Mixts ranging in PA content from 70 to 90%, and α -Mononitronaphthalene content from 10 to 30% were evaluated: color, light cream yel; d (cast) about 1.60g/cc; mp 90 to 105° ; ballistic strength, 74 to 94% TNT; brisance, 32 to 40.5g sand crushed; expln temp, 300 to 315° ; vel of deton, 5000 to 7020m/sec; impact sensitivity (PicArns app, 2-kg wt), 10 to 15.5"; rifle bullet sensitivity, 0 to 10% detonations with .30-cal bullets fired from 90'; stability and solubility in solvents—same as PA

The Fr used a mixt contg 70% PA (Explosif MMN — see Vol 6, E361-R) during WWII

Note: Meyer (Ref 5) states that the term Trimonite is currently the trade name of a free running powder form AN expl distributed in the UK by I.C.I., and can be supplied both cartridge and bulk-packaged

Refs: 1) W.F. Shirk, "Cellulose Acetate, Vinylite, and Polystyrene Resins in Contact with Various Explosives", PATR **1098** (1941) 2) Anon, "Allied and Enemy Explosives", APG, Md (1946), 98-99 3) Anon, "Military Explosives", TM **9-1910** (1955), 214 4) Anon, EngrgDesHndbk, "Explosives Series, Properties of Explosives of Military Interest", AMCP **706-177** (1971), 370-72 5) R. Meyer, "Explosives", Verlag Chemie, NY (1977), 300

Trinal. Same as Trinitronaphthalene (see Vol 8, N12-R to N14-R)

Trinilina or Trinitralina. Span for Trinitroaniline (TNA). See Vol 1, A409-R to A411-L

Trinitril or Trinitryl. Same as Glycerol- α -[2,4,6-Trinitrophenylether] Dinitrate or Dinitro-glycerol Picrate. See in Vol 6, G109-R to G110-L

Trinitroacetonitrile. See in Vol 1, A46-L

2,4,6-Trinitro-3-Ammonoanazole. See in Vol 1, A182-L

2,4,6-Trinitro-3-Aminophenetole. See in Vol 1, A240-R to A241-L

2,4,6-Trinitro-3-Aminophenol. See in Vol 1, A244-L & R

2,4,6-Trinitroaniline (2,4,6-TNA or Picramide). See in Vol 1, A409-R to A411-L, "TNA" in this Vol, and the following *Addnl Refs*: 1) J.M. Rosen & C. Dickinson, "Vapor Pressure and Heats of Sublimation of Some High Melting Organic Explosives", **NOLTR-67-67**, Naval Ordn Lab, Siler Spring (1969) & **CA 70**, 98400 (1969) [The vapor pressure and heat of sublimation of 2,4,6-TNA was detd using the Langmuir method. At 44.0° a vapor pressure of 10^{-7} torr and a molar heat of sublimation of 27.71 kcal (121.5 cal/g) are reported] 2) L.V. Afonina et al, "Method of Evaluating the Tendency of Explosives to Undergo Transition from Burning to Detonation", **Vzryvnoe Delo 1970**, No. 68/25, 149-58 & **CA 73**, 89713 (1970) [An unsuccessful attempt was made to determine the transition from deflagration to detonation of 2,4,6-TNA by compressing the expl to a d of 1.2g/cc in steel tubes of 2.9 and 6.4-6.8mm diam, sealed at both ends with threaded plugs. Ignition was produced by a hot wire acting on a pyrot compn in contact with the expl. The ease of transition from burning to detonation was to be measured by the duration of combustion in the tube before detonation, and the tube expansion after detonation. According to the authors, 2,4,6-TNA burned but did not detonate under the conditions of the expt]

2,4,6-Trinitroanazole. See in Vol 1, A450-L to A452-R

2,4,6-Trinitrobenzaldehyde. See in Vol 2, B35-R

Sym Trinitrobenzene [1,3,5 (or 2,4,6) -Trinitrobenzene or sym TNB]. See in Vol 2, B48-L to B50-L and the following *Addnl Refs*: 1) R.W. Snook, "Properties of Trinitrobenzene Reported in the Literature", **PicArsn Expls Dev Sect Rept 30** (1958) [The properties of cast mixts of sym TNB with TNT or Tetryl are given in Table 1] 2) M. Blais et al, "Preparation of Thermally Stable Explosives: 2,4,6-Trinitrobenzene Derivatives", **PATR 2524** (1958) [Table 2 presents the expl properties of selected 2,4,6-TNB derivatives] 3) J.M. Rosen & H.T. Simmons, "Compatibility of Inorganic Azides with Organic Explosives", **IEC, ProdResDev 1968**, 7 (4), 262-64 & **CA 70**, 13129 (1969) [Both Na and Pb azide react with TNB at 260° as evidenced by the large vol of gas evolved and the formation of a blk insol product whose mp is above 475°. The reaction is interpreted as an oxidn of azide ion by the nitro groups of the expl. It is concluded that this reaction must be considered as a limitation on the use of azides in intimate contact with typical org expls such as TNB at elevated temps] 4) B.N. Kondrikov, "Methods for Determining the Sensitivity of Explosives to Shock", **Vzryvnoe Delo 1970**, No 68/25, 168-73 (Russ) & **CA 73**, 79058 (1970) [The author presents a method of correlating previously independently measured expl impact sensitivity values. Thus, the frequency of sample functioning is detd at initiation and conclusion of a control series using recrystd Tetryl as the standard. Pb Azide, for example, is evaluated alternately with the Tetryl control. The height of recoil of the drop wt inducing the shock is measured at sample functioning or failure as the indexing means. For TNB, the values are in the 13-16cm range. This procedure results in the following order of *decreasing* shock sensitivity: HMX, PETN, Hexanitrodiphenyl sulfate, Tetryl, TNB, TNA and Pb Azide] 5) B.N. Kondrikov et al, "One Method of Determining the Combustibility of Explosives", **Vzryvnoe Delo 1970**, No 68/25, 139-49 (Russ) & **CA 73**, 89715 (1970) [The combusti-

Table 1
Properties of TNB/TNT and Tetryl/TNB Mixtures (Ref 1)

Properties	TNB/TNT 83/17	Tetryl/TNB 81/19
Brisance by sand test, grams of sand crushed by 0.40g expl	52.8	54.8
Cast-loading temp, °C	95	95
M2 Demolition block test	Comparable to Tetrytol	Comparable to Tetrytol
Detonation velocity, m/sec	7006	7427
Fragmentation test, 3 inch AA M42A1 shell	More brisant than TNT	More brisant than TNT
Fragmentation test, 90mm M71 shell	More brisant than TNT	More brisant than TNT
Impact test, PA app, 2-kg weight, inches	12	12
120°C Vacuum Stability test, cc/gas evolved, 40 hrs	0.26	—
120°C Vacuum Stability test, cc/gas evolved, 16 hrs	—	11+

Table 2
The Explosive Properties of Selected 2,4,6-Trinitrobenzene Derivatives

Compound	MP, °	Impact Sensy ^{-a}	Expln Temp, ° ^b	Brisance ^c
1,3,5-Trihydrazino-2,4,6-TNB	241 (decompn)	4	200	100
1,3,5-Tris (methylamino)-2,4,6-TNB	258 (decompn)	10	290	—
1,3,5-Tris (methylnitramino)-2,4,6-TNB	202 (decompn)	5	240	131
1,3-Dihydrazino-2,4,6-TNB	235 (decompn)	6	278	—
1,3-Bis (methylamino)-2,4,6-TNB	240 (decompn)	18	350	—
1,3-Bis (methylnitramino)-2,4,6-TNB	196 (decompn)	6	245	124
2,4,6-Trinitro-methylnitraminobenzene	120	8	260	110
2,4,6-Trinitrobenzaldehyde-2,4,6- trinitrophenylhydrazone	214 (decompn)	—	260	—
Bis (2,4,6-trinitrobenzaldehyde)-2,4,6- trinitrophenyldihydrazone	241 (decompn)	—	290	—
Tris (2,4,6-trinitrobenzaldehyde)-2,4,6- trinitrophenyltrihydrazone	254 (decompn)	—	300	—

Footnotes to Table:

a - inches, PA appar

b - 5 sec value

c - sand bomb test, TNT=100]

bility of expls is characterized by the min wt of a 1:1 NC-powdered AN igniter giving stable combustion in a manometric bomb. Also, from a knowledge of the combustion properties of the igniter and the heat-transfer properties of the expl, the min critical wt of igniter can be calculated. The calculated and exptl wts in g of igniter required for the combustion of TNB is reported as 0.4 and 0.5, resp] 6) L.V. Afonina et al, "Method of Evaluating the Tendency of Explosives to Undergo Transition from Burning to Detonation", *Vzryvnoe Delo* **1970**, No 68/25, 149-58 (Russ) & *CA* **73**, 89713 (1970) [The ease of transition from burning to deton of TNB and other expls was exptly detd by the authors. The TNB was compressed in steel tubes of 2.9 and 6.4 to 6.8mm diam, sealed at both ends with threaded plugs, and able to withstand pressures of 5-12 kilobars. Ign was produced by a hot wire acting on a pyrot compn in contact with the TNB. The ease of transition from burning to deton was measured by duration of combustion in the tube before deton, and the expansion of the tube after deton. The authors report a list of the expls investigated in the order of *decreasing* tendency to deton as follows: Pb Styphnate, PETN, Octogen, Hexogen, PETN desensitized with 5% paraffin oil, DINA, Tetryl, TNB, Styphnic Acid, K picrate, PA and desensitized Hexogen] 7) W. Fisco & O. Haase, "Crystal Growth of Trinitrobenzene . . .", *MaterResBull* **1973**, 8 (9), 1083-88 & *CA* **79**, 140367 (1973) [The authors report growth of substantially perfect crystals up to 2cm in size by the precipitant infusion method] 8) E.G. Kayser, "The Thermal Decomposition of Thirty Commercially Available Materials at 300°C", *NOLTR-74-44* (1974) [Thermal surge data is reported for TNB as an initiation threshold temp of 460° and an expln temp of 848° after a 250-microsec delay. *Note*: the procedure for this test is, ". . . a 2.1μl sample is enclosed in a 6.35cm length of stainless steel tubing which is then pulse-heated to temperatures in the range of 300-1000°C by a capacitor discharge. Both the temperature of the sample container and the time delays to explosion which fall in the range of 50-1000μsec were determined by measuring the resistance of the tubing as a function of time . . ."] 9) G.A. Olah & H.C. Lin, "A Convenient Direct Preparation of 1,3,5-Trinitro-

benzene from m-Dinitrobenzene by Nitration with Nitronium Tetrafluoroborate in Fluoro-sulfuric Acid Solution", *Synthesis*, 444-45 (1979) & *CA* **81**, 77590 (1974) [The developed prepn consists of adding to 200ml of cooled (ice/acet bath) fluorosulfuric acid in a 500ml flask, 9.75 mole of nitronium tetrafluoroborate and 0.25 mole of m-dinitrobenzene, and allowing the mixt to rise to RT with a reflux condenser attached to the flask. The reaction mixt is then heated at 150° with stirring for 38 hrs. It is then poured onto crushed ice, the reaction product extracted with dichloromethane, washed with 5% NaHCO₃, and dried over Mg sulfate. The yield is 49.3% of 100% pure sym TNB] 10) F.B. Wells, "S-Trinitrobenzene as a Binder in Compression-Molded Explosive Compositions", *PATR* **4783** (1975) [Results of a study to replace low mp TNT with sym TNB as a fusible expl matrix in compression molded compns indicate that a mixt of sym TNB and HMX is effective, and that ideal proportions lie between 95/5 and 94/6 HMX/sym TNB, utilizing a pelleting compression of 5000psi. Preliminary work on the inclusion of Teflon in the mixt indicated that ratios of 94.5/4.5/1.0, 93.0/4.5/2.5 and 91.5/4.5/4.0 HMX/sym TNB/Teflon deserved further exploration] 11) J.R. Hendrickson & F.B. Wells, "Castable Composite Explosive Compositions Containing a Mixture of Trinitrobenzene and Trinitroxylene", *USP* 3994756 (1975) & *CA* **86**, 75497 (1976) [The inventors claim a castable expl incorporating TNB (26.25), Trinitro-m-Xylene (3.75) and HMX (70 wt %) which passes the mandatory requirements for qualification as a mil expl. The TNB and Trinitro-m-Xylene form a low mp matrix to which the higher mp HMX is added while the mixt is being processed at 15psi (steam) and temps ≥118°] 12) R. Meyer, "Explosives", *Verlag Chemie*, NY (1977), 302 [Information reported for 1,3,5-Trinitrobenzene includes:

Energy of formation	-23.2kcal/kg
Enthalpy of formation	-39.8kcal/kg
Volume of detonation gases	600ℓ/kg
Heat of expln	1275kcal/kg
Specific energy	93.4mt/kg
Melting enthalpy	16.0kcal/kg

Vapor pressure

Millibar	Temp	
	°C	°F
0.5	122	252 (mp)
2	150	302
14	200	392
133	270	518
Pb block test	325cc/10g	
Detonation velocity	7300m/sec	
Impact sensitivity	0.75kp/m	
Friction sensitivity	Up to 36kp pistil load, no reaction	

13) A. Delpuech & J. Cherville, "Relation Between the Electronic Structure and the Pyrotechnic Sensitivity of Secondary Nitrogen Explosives", SympChemProblConnectedStabExpls [Proc] 1976, 4, 179-99 (1977) (Fr) & CA 87, 120025 (1977) [The excited molecular state of TNB (as during the initial stage of deton) has been examined by UV absorption spectroscopy (195-360 micron wave length band) after irradiation by 100eV with 1 Mrad. TNB exhibited weakening of the R-NO₂ bonds, and low pyrot initiation sensy]

14) C. Capellos & S. Iyer, "Energetic Transient Species Formed via Electronic Excitation of S-TNB and S-TNT", ARRADCOM 1978 (AD-A056417) & CA 90, 74059 (1979) [Electronic excitation of S-TNB by flash photolysis in aerated protic solvents was found to generate a transient species the yield of which is a function of oxygen concn. Examination of spectroscopic and kinetic data suggests the formation of a complex between S-TNB and oxygen. The authors conclude from their study of the transient states of S-TNB and S-TNT that a means is suggested to modify the initiation threshold of nitroaromatic expl compds by the formation of a charge transfer complex or ionized salt using compds such as Me₄NB₃H₈(QMB₃), Na hydroxide or Na iodide added to the molten expl]

15) M.J. Kamlet & H.G. Adolf, "The Relationship of Impact Sensitivity with Structure of Organic High Explosives. II. Polynitroaromatic Explosives", Propants&Expls 4, 30-34 (1979) & CA 91, 59620 (1979) [For classes of expls with similar decompn mechanisms, there appear to be statistically significant linear relationships (sensitivity/composition trends) between logarithmic 50% impact heights and values of OB₁₀₀, a measure

of oxidant balance. This term is defined as follows:

$$OB_{100} = \frac{100(2n_O - n_H - 2n_C - 2n_{COO})}{mw}$$

where n_O, n_H and n_C represent the number of atoms of the respective elements in the molecule, and n_{COO} is the number of carboxyl groups

The values of these parameters are shown in Table 3 for a large number of expls including sym TNB

The statistical correlation is shown as Fig 1

In addition, it is shown that polynitroaromatic expls contg a C-H linkage alpha to the aromatic ring are more impact sensitive as a class than expls lacking such a linkage]

Trinitrobenzoic Acids. See in Vol 2, B73-L to B75-R

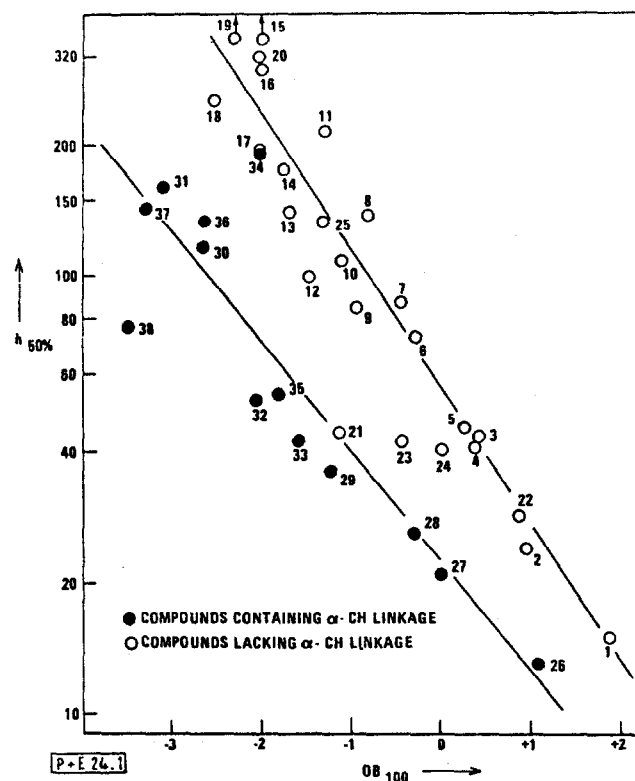

Fig 1 Impact Sensitivity of Polynitroaromatics as Function of OB₁₀₀ (from Ref 15)

Table 3
Impact Sensitivities and Oxidant Balances of Polynitroaromatic Explosives (from Ref 15)

No. Compound	Molecular Formula	Mol Wt	OB _{mole}	OB ₁₀₀	H _{50%} (cm)	
COMPOUNDS WITH NO ALPHA C-H LINKAGE						
1.	2,3,4,5,6-pentanitroaniline	C ₆ H ₂ N ₆ O ₁₀	318	+6	+1.88	15
2.	2,2,2-trinitroethyl-2,4,6-trinitrobenzoate	C ₉ H ₄ N ₆ O ₁₄	420	+4	+0.95	24
3.	2,4,6-trinitroresorcinol	C ₆ H ₃ N ₃ O ₈	245	+1	+0.41	43
4.	2,3,4,6-tetranitroaniline	C ₆ H ₃ N ₅ O ₈	273	+1	+0.37	41
5.	2,2,2-trinitroethyl-3,5-dinitrosalicylate	C ₉ H ₅ N ₅ O ₁₃	391	+1	+0.26	45
6.	2,2,2-trinitroethyl-3,5-dinitrobenzoate	C ₉ H ₅ N ₅ O ₁₂	375	-1	-0.28	73
7.	picric acid	C ₆ H ₃ N ₃ O ₇	229	-1	-0.44	87
8.	2,4,6-trinitro-3-aminophenol	C ₆ H ₄ N ₄ O ₇	244	-2	-0.81	138
9.	2,2',4,4',6,6'-hexanitrobiphenyl	C ₁₂ H ₄ N ₆ O ₁₂	424	-4	-0.94	85
10.	2,4,6-trinitrobenzoic acid	C ₇ H ₃ N ₃ O ₈	257	-3	-1.12	109
11.	2,2-dinitropropyl-2,4,6-trinitrobenzoate	C ₁₀ H ₇ N ₅ O ₁₂	389	-5	-1.28	214
12.	1,3,5-trinitrobenzene	C ₆ H ₃ N ₃ O ₆	213	-3	-1.46	100
13.	2,4,6-trinitrobenzotrile	C ₇ H ₂ N ₄ O ₆	238	-4	-1.68	140
14.	picramide	C ₆ H ₄ N ₄ O ₆	228	-4	-1.75	177
15.	4,6-dinitroresorcinol	C ₆ H ₄ N ₂ O ₆	200	-4	-2.00	>320
16.	2,4-dinitroresorcinol	C ₆ H ₄ N ₂ O ₆	200	-4	-2.00	296
17.	2,4,6-trinitroanisole	C ₇ H ₅ N ₃ O ₇	243	-5	-2.06	192
18.	1,3-dimethoxy-2,4,6-trinitrobenzene	C ₈ H ₇ N ₃ O ₈	273	-7	-2.56	251
19.	3-methoxy-2,4,6-trinitroaniline	C ₇ H ₆ N ₄ O ₇	258	-6	-2.32	>320
20.	2,3-diamino-2,4,6-trinitrobenzene	C ₆ H ₅ N ₅ O ₆	243	-5	-2.06	320
21.	2,2',4,4',6,6'-hexanitrodiphenylamine	C ₁₂ H ₅ N ₇ O ₁₂	439	-5	-1.14	48
22.	2,4,6-trinitrophenol	C ₆ H ₃ N ₃ O ₉	261	+3	+1.15	27
23.	3-hydroxy-2,2',4,4',6,6'-hexanitrobiphenyl	C ₁₂ H ₄ N ₆ O ₁₃	440	-2	-0.45	42
24.	3,3'-dihydroxy-2,2',4,4',6,6'-hexanitrobiphenyl	C ₁₂ H ₄ N ₆ O ₁₄	456	0	0.00	40
25.	3,3'-diamino-2,2',4,4',6,6'-hexanitrobiphenyl	C ₁₂ H ₆ N ₈ O ₁₂	454	-6	-1.32	132
COMPOUNDS WITH ALPHA C-H LINKAGE						
26.	1-(2,2,2-trinitroethyl)-2,4,6-trinitrobenzene	C ₈ H ₄ N ₆ O ₁₂	376	+4	+1.07	13
27.	1-(3,3,3-trinitropropyl)-2,4,6-trinitrobenzene	C ₉ H ₆ N ₆ O ₁₂	390	0	0.00	21
28.	1-(2,2,2-trinitroethyl)-2,4-dinitrobenzene	C ₈ H ₅ N ₅ O ₁₀	331	-1	-0.30	31
29.	2,4,6-trinitrobenzaldehyde	C ₇ H ₃ N ₃ O ₇	241	-3	-1.24	36
30.	2,2',4,4',6,6'-hexanitrobiphenyl	C ₁₄ H ₈ N ₆ O ₁₂	452	-12	-2.64	114
31.	TNT	C ₇ H ₅ N ₃ O ₆	227	-7	-3.08	160
32.	2,4,6-trinitrobenzyl alcohol	C ₇ H ₅ N ₃ O ₇	243	-5	-2.06	52
33.	2,4,6-trinitrobenzaloxime	C ₇ H ₄ N ₄ O ₇	256	-4	-1.56	42
34.	2,4,6-trinitro-m-cresol	C ₇ H ₅ N ₃ O ₇	243	-5	-2.06	191
35.	3-methyl-2,2',4,4',6,6'-hexanitrobiphenyl	C ₁₃ H ₆ N ₆ O ₁₂	438	-8	-1.81	53
36.	3,3'-dimethyl-2,2',4,4',6,6'-hexanitrobiphenyl	C ₁₄ H ₈ N ₆ O ₁₄	452	-12	-2.64	135
37.	3-methyl-2,2',4,4',6-pentanitrobiphenyl	C ₁₃ H ₇ N ₅ O ₁₀	393	-13	-3.30	143
38.	3,5-dimethyl-2,4,6-trinitrophenol	C ₈ H ₇ N ₃ O ₇	257	-9	-3.50	77

2,4,6-Trinitrobenzotrifluoride. See in this Vol under "TNTF"

2,4,6-Trinitrobenzyl Nitrate. See in Vol 2, B92-L & R

Trinitrobutyramide. See in Vol 2, B391-L and the following *Addnl Ref*: R.H. Saunders, USP 3002022 (1962) & CA 56, 622 (1962) [The inventor reports an OB to CO₂ of -29%; a mp of 92°; an ign time at 220° of 2 secs; and a 50% pt impact sensy of 56cm (2-kg wt)]

Trinitrobutyric Acid Ester of 2,2-Dinitro-1,3-Propyleneglycol.

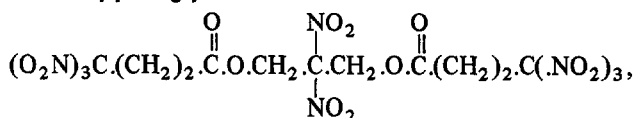

C₁₁H₁₂N₈O₂₀; mw 576.31; N 19.45%; OB to CO₂ -22.21%; cryst; mp 144°; d 1.68g/cc.

Prepn is by addn of nitroform to acrylate ester. The compd has a hot bar ign temp of 235° and an impact sensy about that of Compn A

Refs: 1) Beil, not found 2) W.F. Sager & D.V. Sickman, "Second Report on Research and Development in New Chemical High Explosives", NAVORD 483 (1952), 15

2,4,6-Trinitro-m-Cresol. See in Vol 3, C559-R

Trinitro-N,N-Dimethylanilines. See in Vol 5, D1315-R

2,4,6-Trinitro-1,3-Di(Methylnitramino) Benzene [Ditetryl (Brit)]

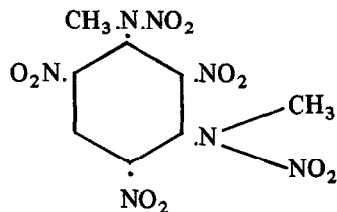

C₈H₇N₇O₁₀; mw 361.22; N 27.15%; OB to CO₂ -42.08%; mp 206°. Prepn is by treating 2,3,4,6-

tetranitrophenylmethylnitramine with methylamine to replace the 3-nitro group by a methylamino group; the resulting product is then nitrated

Brit Ditetryl explds at 214° when heated at a rate of 20°/min; at 197° when 5°/min. It has an impact sensy of 21-26cm (2-kg wt in Kast app, Tetryl=49-51cm); power by Pb block expansion of greater than 75% that of Dynamite; and a thermal stability at 95°/4 days of decompn with evolution of oxides of nitrogen

The name *Ditetryl* is used in the USA to refer to N,N'-(Hexanitrodiphenyl) ethylenedinitramine (Ref 2). See also Vol 2, B131-R to B132-L, and Vol 5, D1513-L & R

Refs: 1) Beil 13, 61, (18) & [34] 2) Blatt, OSRD 2014 (1944) 3) Urbanski 3 (1967), 65-66

2,4,6-Trinitro-1,3-Di(β-Nitroxyethyl) Benzene

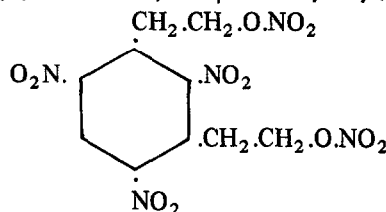

C₁₀H₉N₄O₁₂; mw 391.24; N 17.90%; OB to CO₂ -51.12%; oil. Prepn is by condensing trinitro-m-xylene with formaldehyde, and nitrating the product. The compd can be detond with a hammer blow

Refs: 1) Beil, not found 2) Blatt, OSRD 2014 (1944)

2,2,2-Trinitroethanol, 1-Phenyl.

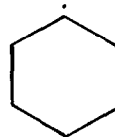
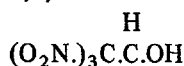

C₈H₇N₃O₇; mw 257.18; N 16.24%; OB to CO₂ -77.77%; white crysts; mp 78°. Sol in hot methanol; insol in cold w. Prepn is by reacting nitroform with benzaldehyde at 64°. The compd has an impact sensy of 60cm (BuMines app, 2-kg wt), and an 82.2° KI-starch stability test value of

5 minutes

Refs: 1) Beil, not found 2) R.H. Saunders, USP 2993936 (1961) & CA 55, 24016 (1961)

N-(β,β -Trinitroethyl)-Acetamide.

$\text{CH}_3\text{-}\overset{\text{O}}{\underset{\text{||}}{\text{C}}}\text{-NH-CH}_2\text{-C}(\text{NO}_2)_3$, $\text{C}_4\text{H}_6\text{N}_4\text{O}_6$; mw 206.14; N 27.19%; OB to CO_2 -38.81%; white ndles; mp 91-92°. Sol in hot ethanol-w mixt. Prepn is as follows: Acetamide in satd aq Ba hydroxide is mixed with 37% formalin at RT, then satd with CO_2 and filtered. The filtrate is then mixed with 4.5p of trinitromethane, the soln left standing a few minutes, and then heated at 75-80° to complete the reaction. After recrystn of the crude product from ethanol-w a 46% yield is obtd. The compd has an impact sensy of 35cm using a 2.5-kg wt

Refs: 1) Beil, not found 2) P.O. Tawney, USP 3038010 (1962) & CA 57, 7512 (1963)

β -Trinitroethyl Alcohol. See in Vol 6, E179-R to E180-L and the following *Addnl Ref*: K.G. Shipp & M.E. Hill, "An Improved Process for the Preparation of 2,2,2-Trinitroethanol, TNEOH", NAVORD 6752 (1960) [The authors report a prepn without isolation of intermediates; viz, tetranitromethane is reduced to Na nitroform, which is then simultaneously acidified and formulated by a soln of paraformaldehyde in hydrochloric acid. A stable oil in 80-85% yield is obtd. Pure crystn trinitroethanol is obtainable then, from chlorinated solvent solns of the oil dried by azeotropic distn. Also reported are the following properties: mp 73.5-74°; d 1.70g/cc; v sol in glacial acetic acid and hot C tetrachloride; sol in chl, methanol and w; sl sol in C tetrachloride and hexane; 50% pt impact sensy (2.5-kg wt) is 11cm (pure crystals, RDX=24cm), 25cm (wet with C tetrachloride), 22cm (monohydrate), and 86-101cm (as crude prodn oil); vac stab test, sublimes easily under reduced press]

N-Trinitroethyl Benzenesulfonamide.

$\text{SO}_2\text{-NH-CH}_2\text{-C}(\text{NO}_2)_3$, $\text{C}_8\text{H}_8\text{N}_4\text{O}_8\text{S}$;

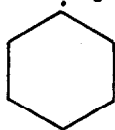

mw 192.26; N 29.15%; OB to CO_2 -99.86%; cryst; mp 172°; d 1.64g/cc. Prepn is from the sulfonamide by fusion with excess trinitroethanol at 100°. The compd has an ign temp of 188° and an impact sensy the same as Comp B
Refs: 1) Beil, not found 2) W.F. Sager & D.V. Sickman, "Second Report on Research and Development in New Chemical High Explosives", NAVORD 483 (1952), 12

Bis (Trinitroethyl) Carbonate (BTNEC).

$(\text{O}_2\text{N})_3\text{C-CH}_2\text{-O-}\overset{\text{O}}{\underset{\text{||}}{\text{C}}}\text{-O-CH}_2\text{-C}(\text{NO}_2)_3$, $\text{C}_5\text{H}_4\text{N}_6\text{O}_{15}$; mw 388.15; N 21.66%; OB to CO_2 12.37%; cryst; mp 115°; d 1.88g/cc. Sol in acet, eth, hot chl and C tetrachloride; insol in cold hexane or solvent mixts with cold hexane. Prepn involves conversion of 2,2,2-trinitroethanol to methyltrinitroethyl carbonate by treatment with methylchlorocarbonate using a catalyst of Al or Ti chloride, followed by a second reaction with more 2,2,2-trinitroethanol in the form of its compd with Al chloride. Product isolation is accomplished with eth extraction, w and dil Na bicarbonate soln washing, followed by 70% solvent evapn and crystn with cold hexane addn. The yield varies in the process between 45-50%. The carbonate has a 50% pt impact sensy of 16cm (NOL app, 2.5-kg wt), and a vac stab value of 0.9cc of gas/g in 48 hrs at 100°

Refs: 1) Beil, not found 2) M.E. Hill, "Preparation and Properties of Bis (Trinitroethyl) Carbonate", NAVORD 3656 (1953)
3) M.E. Hill et al, "Development of the Synthesis of Bis (Trinitroethyl) Carbonate, BTNEC, A New Oxygen Rich High Explosive", NAVORD 3469 (1955)

Trinitroethyl-3,5-Dinitrobenzoate.

$\text{COO-CH}_2\text{-C}(\text{NO}_2)_3$

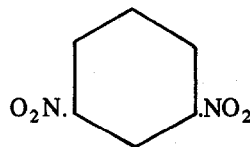

$\text{C}_9\text{H}_5\text{N}_5\text{O}_{12}$; mw 375.19; N 18.67%; OB to CO_2 -36.25%; cryst; mp 138°. Prepn is by reacting benzoic acid chloride with trinitroethanol. The ref terms this compd a "good explosive"

Refs: 1) Beil, not found 2) W.F. Sager & D.V. Sickman, "Second Report on Research and Development in New Chemical High Explosives", **NAVORD 483** (1952), 13

Di-Trinitroethylethylenediamine, N,N-nitro-

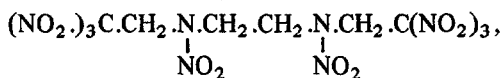

$\text{C}_6\text{H}_8\text{N}_{10}\text{O}_{16}$; mw 476.24; N 29.44%; OB to CO_2 0%; cryst. Prepn is by nitrating ditrinitroethylethylenediamine with a fuming nitric acid-acetic anhydride mixt. The expl has an ign temp of 180° , a heat of expln of 1748kcal/kg, a power by Pb block of 500cc/10g, a vol of deton gases of 712ℓ/kg, and a sensitivity to impact similar to RDX

Refs: 1) Beil, not found 2) K. Shiino, Tokyo-KogyoShikenshoHokoku **1970**, 65 (7), 46-51 & CA **74**, 140812 (1971)

Trinitroethyl Formal. See in this Vol under "TEFO"

Bis (2,2,2-Trinitroethyl)-Nitramine (BTNEN).

See in Vol 5, D1224-R to D1225-L and the following *Addnl Ref*: D.C. Sayles, "Polynitramine Oxidizer-Containing Propellant", USP 3953258 (1976) & CA **86**, 45342 (1977) [The inventor claims that the use of BTNEN as an oxidizer to replace HMX or RDX in fluoroamino smokeless proplnt formulations provides increased performance and has desirable effects on the ballistic parameters. Other proplnt ingredients include ethyl acrylate-acrylic acid copolymer, 1,2,3-tris[1,2-bis(difluoroamino) ethoxy] propane, plasticizer, Amm perchlorate, C black, and a curing agent. Thus, two similar compns contg either HMX or BTNEN were evaluated and exhibited the following characteristics: exhaust velocities of 5152 and 5310ft/sec, thrust coeffs of 1.562 and 1.605, and proplnt flame temps of 2910° and 3356° , respectively. The BTNEN compn also decreased the amt of exhaust after burning]

N-Trinitroethyl-m-Nitrobenzene sulfonamide.

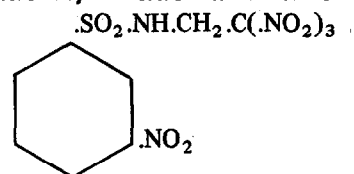

$\text{C}_8\text{H}_7\text{N}_5\text{O}_{10}\text{S}$; mw 365.26; N 19.18%; OB to CO_2 -41.61%; cryst; mp 149° ; d 1.70g/cc. Prepn is from the sulfonamide by fusing at 90° with twice the theoretical quantity of trinitroethanol. The compd has a hot bar ign temp of 198° , and an impact sensy roughly that of TNT
Refs: 1) Beil, not found 2) W.F. Sager & D.V. Sickman, "Second Report on Research and Development in New Chemical High Explosives", **NAVORD 483** (1952), 12

N-Trinitroethyl-p-Nitrobenzenesulfonamide.

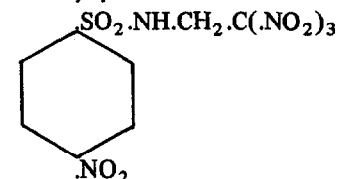

$\text{C}_8\text{H}_7\text{N}_5\text{O}_{10}\text{S}$; mw 365.26; N 19.18%; OB to CO_2 -41.61%; cryst; mp 178° ; d 1.79g/cc. Prepn is from the sulfonamide by fusion at 70° with twice the theoretical quantity of trinitroethanol. The compd has an ign temp of 206° and an impact sensy equivalent to Comp B
Refs: 1) Beil, not found 2) W.F. Sager & D.V. Sickman, "Second Report on Research and Development in New Chemical High Explosives", **NAVORD 483** (1952), 12

Trinitroethyl-m-Nitrobenzoate.

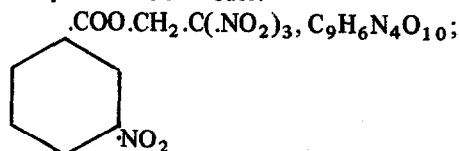

mw 330.19; N 16.97%; OB to CO_2 -53.30%; cryst; mp 97° . Prepn is by nitration of trinitroethyl benzoate. The compd has an impact sensy about that of Comp B
Refs: 1) Beil, not found 2) W.F. Sager & D.V. Sickman, "Second Report on Research and Development in New Chemical High Explosives", **NAVORD 483** (1952), 26

2,2,3-Trinitro-3-Ethylpentane. See in Vol 6, E315-L

Trinitroethyl-2,4,6-Trinitrobenzoate (TTB).
 $\text{COO.CH}_2.\text{C}(\text{NO}_2)_3$

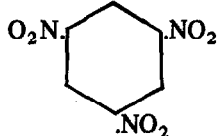

$\text{C}_9\text{H}_4\text{N}_6\text{O}_{12}$; mw 388.19; N 21.65%; OB to CO_2 -32.97%; two polymorphs exist: form I (predominant) is RT stable (to 135°), existing as a lath-shaped or massive equant cryst; form II exists as ndles which are metastable at RT and stable above 147° ; mp, I is 135° , II is 147° . Sol in NB (18g/100cc at 25°). Prepn is by either of two procedures: a) conversion of 2,4,6-trinitrobenzoic acid to its chloride in NB soln followed by esterification in this soln with trinitroethanol in yields of 82%, and b) direct esterification of 2,4,6-trinitrobenzoic acid with trinitroethanol in 6% oleum with 65% yield. The ester has a 50% pt impact sensy of 18cm (ERL app, 2.5-kg wt, Tetryl=35cm)

Refs: 1) Beil, not found 2) D.W. Jensen & O.H. Johnson, "Development of a Practical Synthesis for the New High Explosive, Trinitroethyl-2,4,6-Trinitroethylbenzoate (TTB)", NAVORD 3565 (1953)

N-(β,β,β -Trinitroethyl)-4,4,4-Trinitrobutyramide.

$(\text{O}_2\text{N})_3\text{C.CH}_2.\text{CH}_2.\overset{\text{O}}{\underset{\text{O}}{\text{C}}}\text{NH.CH}_2.\text{C}(\text{NO}_2)_3$,
 $\text{C}_6\text{H}_7\text{N}_6\text{O}_{13}$; mw 371.19; N 22.65%; OB to CO_2 -8.62%; colorl rosettes; mp $149-51^\circ$ (decompn). Sol in hot methanol; insol in cold methanol. Prepn is by treating acrylamide with trinitromethane, then treating the resulting 4,4,4-trinitrobutyramide with formaldehyde, and finally treating the resulting methylol deriv with a second mole of trinitromethane. The inventor claims that the compd can be used as an expl and proplnt

Refs: 1) Beil, not found 2) I.J. Schaffner, USP 3038009 (1962) & CA 57, 12330 (1962)

2,2,2-Trinitroethyl- γ,γ,γ -Trinitrobutyrate.

$(\text{O}_2\text{N})_3\text{C.CH}_2.\overset{\text{O}}{\underset{\text{O}}{\text{C}}}(\text{C}_2\text{H}_4).\text{C}(\text{NO}_2)_3$,

$\text{C}_6\text{H}_6\text{N}_6\text{O}_{14}$; mw 368.18; N 21.77%; OB to CO_2 -4.14%; cryst; mp 86° . Sol in hot methanol-w mixt. Prepn is by treating trinitroethyl acrylate with an excess of trinitromethane at 58° and recrystg the solid product from methanol-w soln. The compd has an ign time of 18 secs at 220° and an impact sensy of 30cm (2-kg wt)
 Refs: 1) Beil, not found 2) R.A. Saunders, USP 2996537 (1961) & CA 55, 26448 (1961)

Trinitroglycerin (Nitroglycerin, Glycerol Trinitrate, NG). See in Vol 3, C501-L to C506-L under "Continuous Methods for Manufacturing Explosives"; Vol 5, D1593-L to D1594-L under "Nitroglycerin (NG) or Glycerol Trinitrate"; Vol 6, G98-R to G108-L under "Glycerol Trinitrate or Nitroglycerin (NG)"; Vol 8, N56-R to N62-L under "NG", main heading of "Nitration" beginning on N40-R, also P405-L to P406-R, Tables 2 & 3 on P407, P408-L & Table 4 on P 408, P415-R, P420-L to P421-R, Table 26 on P431, Table 46 on P443, Table 53 on P450, and Table 54 on P452 under "Propellants, Solid" on P402-L; and the following *Addnl Refs*:

A. *General*: 1) Beil 1, {2762} (under 1,2,3-Tris-nitryloxy Propane) 2) CA Registry No [55-63-0]

B. *Explosives; Analysis*: 1) E. Steeman, "Pulse Polarographic Determination of Trinitroglycerin in Explosives", BullBelg 86 (12), 17-21 (1977) & CA 86, 192063 (1977) [Reported is a quant pulse polarographic technique for the measurement of NG with a reproducibility of 0.5%] 2) W.L. Rollwitz & D.J. King, "Fundamentals of Nuclear Magnetic Resonance for the Detection and Identification of Explosives", Proc New Concepts Symp Workshop Detection Ident Expls, 377-89 (1978) & CA 91, 59627 (1979) [The authors report on their development of a one-instrument combination of hydrogen and nitrogen-14 NMR which can qualitatively detect all hidden untagged expls except for BlkPdr (ESR is used for this). The detection of NG in Dynamite, when mixed with other materials, is accomplished with a useful signal/noise ratio of 10 for the hydrogen content (12×10^{21} nuclei/g of NG, using a specific magnetic field strength of 705G at 3.0MHz frequency) and 1.2 for the nitrogen-14 content (7.2×10^{21} nitrogen nuclei/g of NG, using a specific magnetic field strength of 9760G at 3.0MHz frequency) with a

filling factor of 0.1, using hydrogen transient NMR signals. The combined hydrogen–nitrogen-14 NMR instrument can be used to separate H₂–NMR signals from NG from other compds by using the differences in their relaxation times and the effects of level-crossing or thermal mixing]

Detonation Propagation: R.W. Watson, "Structure of Low Velocity Detonation Waves", 12th Proc Int Symp Combustn, 723–29, July 1968 (1969) & CA 74, 128329 (1971) [Use of high-speed photography and flash radiography to examine the low velocity regime (sub- to near sonic) of NG and 50/50 NG/EGDN detons in thin-walled Plexiglas tubes is reported. Observations strongly support the fluid cavitation model in the propagation of subsonic reactions]

Manufacture: J.D. Thwaites, "Glycerol–Production and Uses", Chem&Ind, 1005 (1969) & CA 71, 112303 (1969) [The author reports that the use of glycerine to manuf NG rose from 8% of the total output of both Europe and the USA in 1955 to 15% in 1967]

New Explosive Compositions: 1) P. Lingens & H. Radzewitz, "Explosive Foams", GerP 1930503 (1971) & CA 74, 89338 (1971) [The inventors claim that by using NG in conjunction with stabilizers, foaming agents, anti-freeze compns, <40 wt % of powdered Al or Mg, and a gas to create a foam, an easier and more precise application of expls over porous or uneven surfaces is achieved. Thus, methylamine perchlorate 50, NG 50, Na laurylbenzenesulfonate 0.5, Na myristylbenzenesulfonate 0.5, and glycol 15g are dissolved or suspended in 100ml of w and compressed air blown thru the bottom of the mixing vessel to create a foam having a deton rate of 2100–2300m/sec] 2) Anon, "Explosive Compositions Containing a Nitroglycerin–Nitroglycol Mixture and Ammonium Nitrate", FrP 1592799 (1970) & CA 74, 101283 (1971) [The pat suggests that addn of desensitizing compds such as TNT, dibutylphthalate or diethylene glycol monoethylether in the liq phase of the subject expl compn manuf, plus hydrophobic coatings of C₁₂₋₂₀ alkylamines in the pellet coating phase of manuf, can increase the handling safety of the subject expl compns while their brisance remains unaffected. Thus, the 50% pt impact sensy (2-kg wt) for 60:40 NG–Nitroglycol is 100mm; addn of 10% of any

of the desensitizing compds shown reduces the impact sensy to the 20% pt for a 200mm fall and the 40% pt for a 400mm fall; 20% desensitizer addn produces zero ignitions for 600mm falls] 3) G.M. Gay, "Water-Bearing Explosive Compositions", SAfrP 7003894 (1970) & CA 75, 65777 (1971) [The inventor claims the use of pregelled NG mixts (contg glycols) to immobilize the NG along with various other ingredients to produce an aq gelled expl compn which he loaded into 1.25" x 8" cartridges. These cartridges cannot be detonated by a No 6 blasting cap, but are detonatable using a commercial 1-lb booster, yielding a deton rate of 14929ft/sec] 4) L.N. Roberts, "Liquid Explosives for Well-Fracturing", GerP 2052146 (1971) & CA 75, 111355 (1971) [The inventor suggests that NG along with various other ingredients be used to formulate viscous liq expls capable of being cast which can be safely used for fracturing geological formations to increase the productivity of oil wells. For example, Methyl Nitrate 66, NG 10, RDX 9, powdered Al 12, NC 1, Cab-O-Sil 1 and chalk 1% are mixed to give an expl without spontaneous ign at pumping rates of <50ℓ/min] 5) W. Christmann et al, "High Energy Powdered or Gelatinous Safety Mining Explosives", GerP 2000620 (1971) & CA 75, 119660 (1971) [The inventors suggest that the energy released from sensitized NG–K nitrate–ammonium salt safety expls is increased by addn of alkali metal perchlorates to give a positive OB of 1–6%. They also suggest that Amm nitrate having a surface area >500cm²/g can also be used. Thus, an expl contg NG 5.4, ethylene glycol dinitrate 3.6, K nitrate 44.8, ammonium chloride 23.6, ammonium oxalate 13.2, K perchlorate 8.0 and other ingredients 1.4%, has an OB of +3.7% and exhibits a pendulum energy of 80.5. This is compared to a similar OB compn contg no K perchlorate with a pendulum energy of 71.0]

C. Propellants; Combustion Mechanisms:

1) C.E. Kirby, "Flameless Combustion Mechanism of M-2 Double-Base Propellant", NASA Tech Note TND-6105 (1971) & CA 74, 143953 (1971) [The author reports on the heat of reaction for the flameless combustion of M-2 double-base proplnt (NG 20, NC 77, and other ingredients 3%) detd at 2.07–1380kN/m² by the use of differential scanning calorimetry and thermogravimetric analysis. The heat of reaction

was found to vary from 1.17MJ/kg at 2.07kN/m² to 3.02MJ/kg at 1380kN/m², with abrupt changes occurring near 13.8, 138 and 689kN/m². The jumps in the heat of reaction were found to occur at pressures corresponding to jumps in the burning rate and temp jumps in the gas phase. In turn, these jumps are related to successive discrete gas-phase reactions that exist a few hundred micrometers above the deflagrating surface. These reaction zones are shown by the author to move toward the surface as the ambient pressure is increased, and intersect the surface at the same jump pressures. On the basis of these results and the usual construction of a differential scanning calorimeter, the author concludes that the apparatus is inadequate for measurement of the condensed-phase heat of reaction of double-base proplnts, since the heat produced by these gas-phase reactions so close to the surface would also be detected by the instrument's heat-sensing system. The author further reports that comparison of differential scanning calorimetry and thermogravimetric analysis shows that the desorption/vaporization of NG occurs near the onset of significant heating and that no heating occurs before wt loss begins. He concludes from his work that pure "condensed phase" contributions are minor for M-2 double-base proplnt in the flameless combustion zone]

2) V.V. Aleksandrov & S.S. Khlevnoi, "Surface Temperature During the Flameless Burning of Nitroglycerin Propellant", *FizGoreniyaVzryva* 6 (4), 438-43 (1970) (Russ) & *CA* 75, 89714 (1971) [Prior exptn by these authors on a proplnt consisting of NC, NG and DNT indicated that the surface temp, T_s , in flameless combustion does not depend on the initial temp. Other prior work to explore T_s involved measurement of the mean heat of vapn of NG and other proplnt volatiles at elevated temps and pressures. These measurements provided an estimate of ~ 26 kcal/mole for this mean heat of vapn. On the assumption that vapn of the more volatile components of this proplnt (such as NG) determines T_s , a formula was derived for the relation between pressure, p , and T_s . On this basis T_s at a press of ≤ 20 -30mm was calcd to be ≤ 194 -98°. However, exptl determinations showed values of 300-10° for T_s at this press. Therefore, vapn of the volatile components of an NG proplnt does not determine T_s . Now, the

work reported in this article as current (ca 1970) consists of surface temp measurements of NG proplnt tablets heated in a vac in which the authors attempt to relate diffusion of the more volatile components of the NG proplnt to the proplnt surface, followed by their evapn, to T_s . This leads to a surface comprised entirely of NC which is overheated to a temp above the bp of the volatile components. The authors conclude that if flameless combustion of NG proplnt took place at a T_s equal to the bp of the volatile components (~ 200 -230°), the combustion rate would be lower by a factor of 18-50 than that observed exptly]

3) R.A. Fifer & J.A. Lannon, "Effect of Pressure and Some Lead Salts on the Chemistry of Solid Propellant Combustion", *Combustn&Flame* 24, 369-80 (1975) & *CA* 84, 182190 (1976) [The reported work consists of qual and quant measurement of the final combustion products at 1, 20 and 40 atms press for laser-ignited thin film samples of NC (12.6% N) and 60% NC-40% NG compn, as well as for the single-base and double-base proplnts catalyzed by Pb oxide or Pb salicylate. Expts were also carried out with NC samples pretreated with NO₂ or w vapor, or burned in an atm contg oxygen. Pb catalysts lead to an increase in CO₂ relative to CO at pressures where super rate burning is expected. This is an exothermic process, and explains the higher surface and dark zone temps, the higher caloric heat output, and faster burning rates for the leaded proplnts. With increasing pressure, CO increases relative to CO₂ and NO is reduced to N₂. Dissolved w-vapor or pretreatment with NO₂ have no measureable effect on the combustion chemistry, but small amounts of O₂ catalyze the oxidation of CO to CO₂, and the reduction of NO to N₂

The authors propose the following mechanisms to account for these observed features of solid proplnt combstn chemistry: a) *catalysis* by Pb compds takes place mainly in or on the burning surface and/or in the fizz zone; b) NO reduction takes place mainly in the secondary flame zone; c) the catalytic effect of Pb compds is accounted for by increased heat output of the solid (or surface) phase coupled with the increased conductive heat transfer to the surface; d) the cycle of Pb to PbO, then reduction to Pb, is explained if one assumes that the unnitrated hydroxyl groups of the proplnt are directly in-

volved in some rate-determining step of the solid phase decomposition; since NG has no hydroxyl groups *NG decomps* is not catalyzed by Pb compounds, and therefore the chemical effects of Pb catalysts are the same for both single and double-base propellants; e) the increase in CO is caused by the oxidation of formaldehyde and hydrocarbon species, $\text{HCHO} + \text{NO} \rightarrow \text{CO} + \text{H}_2\text{O} + \frac{1}{2}\text{N}_2$, where $\Delta H = -78\text{kcal/mole}$; and f) the effect of a smaller decrease in CO_2 with increasing pressure is probably due to the reaction, $\text{C (solid)} + \text{CO}_2 \rightarrow 2\text{CO}$, where $\Delta H = 41\text{kcal/mole}$, i.e., "... carbon particles formed via solid phase exothermic reactions are blown off the burning surface by the evolving gases, pass thru a secondary flame zone and are there oxidized by reaction with CO_2 ..."]

4) A.P. Denisuyk et al, "Effect of the Initial Temperature and Pressure on the Efficiency of the Effect of a Combined Catalyst During Combustion Nitroglycerin Propellants", *TrMoskKhimTekhnol-Inst* **83**, 114-18 (1974) (Russ) & *CA* **85**, 162848 (1976) [The authors report on the effect of PbO_2 and CuO catalysts on the combustion rate (CR) of NG propellants at different initial charge temps and pressures. Incorporation of 1% CuO increased the CR weakly. It was found that the PbO_2 effect in a combined catalyst depended on the pressure and the relationship between PbO_2 and CuO . Such a catalyst increased the CR 2.7 times and in some regions altered the relation to the pressure. At raised initial temps the efficiency of the catalyst effect fell. The authors further report that in a vac, the CuO not only failed to reinforce but even weakened the PbO_2 effect. Also, the CuO further increased the pressure, beginning when the propellant burned stably. They also found that the efficiency of the catalyst effect depends greatly on combustion conditions. For example, it was found that the higher the charge temp, the lower the pressure at which the PbO_2 was active. At a similar initial temp in a vac, the CR of the std compn was low, the PbO_2 (it is concluded) having acted effectively in the propellant]

5) A.S. Androsov et al, "Mechanism of the Effect of Composite Lead-Copper Catalysts on Powder Combustion", *CombustnExplShockWaves* **14** (2), 184-87 (Mar-Apr 1978) & *CA* **89**, 61988 (1979) [The authors report on their attempt to describe the mechanism for the action of CuO and a compo-

site Pb and Cu catalyst in oxidation reactions involved in the thermal decomposition of NG and NG-NC compounds. According to the authors, the main effect of CuO on NG is to catalyze the oxidation of CO to CO_2 . They reason that this is due to the oxygen of NO_2 . They conclude that at temps over 150° , irreversible poisoning of the CuO surface occurs by CO thus decreasing the catalytic effect. On further experiment involving mixtures of NG with NC they report, "... 2. On introducing nitroglycerine in the nitrocellulose, the effect of copper oxide sharply decreases, and at more than 40% NG it disappears completely. In the thermal decomposition of NG much more CO than CO_2 is formed, and in the decomposition of NC more CO_2 than CO is formed. Hence, on introducing NG into NC, the proportion of CO in the decomposition products is increased. The CO/CO_2 ratio in the decomposition products of NC, NG, and their mixtures ($V = 20\text{cm}^3/\text{g}$ at STP) is as follows:

NG content, %	CO/CO_2
0	0.5
10	0.6
20	0.8
98	1.7
100	3.50

It may be assumed that qualitatively the same picture is obtained in combustion, i.e., in comparison with NC, the reactive layer of the condensed phase of the two-component NC-NG mixture is enriched with CO . Therefore, as noted above, the degree to which the CuO surface is poisoned may be increased, and as a result its effect on the combustion of linear mixtures is reduced.

3. The mechanism for the action of a composite catalyst consisting of lead and copper oxides may be developed as follows. ... It was established (in prior work) that lead oxides increase the proportion of N_2O and CO_2 in the decomposition products of NC and powders, reduce the proportion of CO , and lead to the appearance of hydrogen. PbO has a similar effect on the decomposition of NG (Table 2). Thus, lead oxides alter the composition of the products obtained in the decomposition of powders so that there is a higher concentration of nitrous oxide, the most active oxidizing agent in the conditions of combustion, and less carbon mon-

Table 2
Effect of PbO on the Rate and Composition of the Products in the Decomposition of NG
($t = 140^{\circ}\text{C}$, $V = 20\text{cm}^3/\text{g}$ at STP)

Sample	Rate of Decomposition, $\text{cm}^3/\text{g min}$ (STP)	Composition of products, %						
		NO_2	N_2	NO	N_2O	CO	CO_2	H_2
NG	0.45	55	1	17	—	21	6	—
NG with PbO	0.48	43	3	17	15	2	17	3

oxide, which may poison the copper oxide, and in this way favorable conditions are created for the oxide to show catalytic properties in the oxidation of the intermediate products of the thermal conversion of the powder components ...”

6) I.Ya. Vishnivetskii et al, “Critical Conditions for the Combustion of Ballistite Propellants”, *FizGoreniyaVzryva* **15** (1), 12–18 (1979) (Russ) & *CA* **91**, 76311 (1979) [Work on the parameters effecting the critical charge diam (D_{crit}) of a ballistite proplnt comprised of NC 49, NG 49, petrolatum 1 and ethyl centralite 1% is reported. These parameters consist of the effect of the actual charge diam (D) on the combstn rate and the behavior of the secondary flame (front). Charge geometries investigated where these parameters applied consisted of cylinders and 0.05 to 2.2mm thick plate charges at pressures of 1 to 20kg/cm². The authors found that D_{crit} for a plate charge is equal to 4 (surface area)/plate cross-section perimeter. The results of further tests showed that the combstn rate increases with increasing diam. The highest increase in combstn rate was observed when the increase in D/D_{crit} went from 1 to 2. Also, the min pressure (p) at which a secondary flame was formed in the exptl proplnt increased with decreasing diam according to the eqn, $D = 283p^{-1.48}$. The authors conclude that the exptl data agreed with the Zel’dovich theory for the combustion of ballistite proplnts]

Ignition Parameters: B.N. Kondrikov et al, “Ignition and Gasification of Ballistite Powder Under the Effect of Carbon Dioxide Laser Radiation”, *TrMoskKhimTekhnolInst* **83**, 67–78 (1974) (Russ) & *CA* **85**, 162865 (1976) [Reported is the effect of CO_2 -laser radiation

(100W, 90kcal/cm²-sec, $\lambda = 10.6$ microns) on the ign and gasification of Ballistite N-5 [NC (13.25% N) 50.00, NG 34.90, diethylphthalate 10.50, 2-nitrodiphenylamine 2.00, Pb salts 2.40, & candellila wax 0.20%], CA Registry No [60730-74-7]; and the M-9 proplnt [NC (13.25% N) ~52.00, NG ~43.00, diethylphthalate ~3.00 & ethyl centralite 0.6%], CA Registry No [60704-06-5] at 1–21atms and various radiation intensities and radiation times. The results of this work are summarized as follows: At 21atm and low radiation intensity the radiation has no effect on the N-5 powder; at high radiation intensities the powder ignites and burns. The activation energy of the combustion is 30.5kcal/mole. The radiation intensity dependence curves of the ignition delay and pressure have mins at 3–5atms indicating the existence of a crit radiation intensity at which there is no effect on the ignition of N-5 powder. At 1atm pressure the ignition of N-5 powder is difficult. Irradn for 3 secs causes only gasification of the powder. At 1–2atms the gasification rate decreases with increasing radiation intensity owing to the radiation retention by the reaction products. Starting at a certain outside energy flux the exothermic reaction changes to endothermic. Under certain conditions the increase in the radiation intensity increases the ignition delay time. The ignition of the M-9 powder with the laser radiation is more difficult. At 65atms there is no ignition of M-9 powder; it ignites at 20–22atms]

Manufacture: Anon, “Explosive Propellant Compositions”, *BritP* 1247564 (1971) & *CA* **75**, 131275 (1971) [It is claimed that by the use of a heated longitudinal kneading (rotating worms) app, substantially dry double-base

proplnt compns are produced continuously by mixing the basic components. Thus, NC 40–70 & NG 60–30 wt p with $\geq 25\%$ w is introduced into one end of the app. The mixt is kneaded by rotating the worms and applying heat to evap the w and produce at the other end the dry compn. The compn may also contain ≤ 10 wt % of a plasticizer, stabilizer or moderator]

New Propnt Compns: 1) O.H. Johnson, "Plasticized High Explosive and Solid Propellant Composition", USP 3389026 (1968) & CA 69, 45026 (1968) [The inventor claims a general purpose compn which, depending on the amt of oxidizer (NG) used is either an expl (40–70%) or a proplnt (25–50%). Thus, 10g of a mixt of NG 49.0, guncotton 23.1 and Al powder 27.9% is treated with 80ml of dimethyl ketone to dissolve the organic material, the solvent is then evapd at 25° for 16 hrs, and finally vacuum is applied to form a tough noncrystn proplnt having a Q_{deton} of 2030cal/g. Further processing is by a shock-gel treatment (pptn in a liq in which neither compn nor solvent is soluble) which forms small granules that are suitable for compression molding to form solid proplnt grains] 2) M.J.M. Olsson, "Composition for Diminishing the Flame Production of Explosives", GerP 2530656 (1976) & CA 85, 7959 (1976) [The inventor suggests that addn of a cationic ion resin charged with enough alkali metal cations to create a neutral reaction in aq soln suppresses flame formation in a double-base proplnt. Thus, no flame is observed from a compn contg NC 89.5, NG 5, DPA 1, DNT 1.5 and TNT 1.5p, to which 1.5p of Lewasorb A10 has been added after activation with K ions] 3) J.B. Eldridge, "Solid Propellant Mixtures", USP 3951706 (1976) & CA 85, 65360 (1976) [The inventor claims that by modifying a double-base proplnt (30–50%) by addn of a castable plastisol (nitrasol) binder (50–70%), with or without oxidizer and fuel, a castable solid proplnt having improved and controllable burning characteristics over both types of proplnts is formed. Thus, a mixt of NC 22.8 and ethyl centralite 1.2 is blended for 30 mins with Petrin 96 and then, successively, AP 60 and atomized Al 30g are added. To this mixt is added 90g of 30 mesh double-base proplnt termed "X-12" (consisting of NC 50, NG 38, DPA 5.9, 2-nitrodiphenylamine 2, Pb- β -resorcyate 2 and can-

delilla wax 0.1%). The resulting composite mixt is stirred for 30 mins under vac, cast and cured for 2 hrs at 180–85°F. This compn, designated "JUD 22" by the inventor is claimed to have a plateau-burning curve, while "X-12" alone has a mesa-burning curve] 4) K. Inoue & F. Matsui, "Granular Propellant", JapP 7976813 (1979) & CA 91, 195446 (1979) [The inventors claim improved moldability in a double-base proplnt compn whose binder is crosslinked by the use of a multi-functional isocyanate. Thus, w 89, NC 30, NG 62.8, ethyl acetate 177 and a stabilizer 0.6p are stirred in a stirring tank for 10 mins, mixed with diphenylmethane-4,4'-diisocyanate 6.6, glue 3.3 and w 188p; pelletized, the excess solvent removed by vac distln, heated in w at 50°, de-watered and dried to obtain a granular proplnt (0.8mm avg diam & 0.09mm avg thickness). Use of the invented proplnt in a shotgun gives an initial velocity of 315m/sec with no residue]

Parameter Measurements: J.R. Ward, "Specific Heat of X14 Propellant", AIAAJ 12 (1), 107–10 (1974) & CA 81, 15257 (1974) [Using DSC measurements of X14 proplnt (an NC–NG compn) to determine best-fit values, the author derived the appropriate "a" and "b" values to fit the specific heat eqn in the 283–343°K range using a non-linear least squares computer program; viz,

$$\bar{C}_p = a + bT - CT^{-2}$$

where $a = 0.118 \text{ cal/g} \cdot ^\circ\text{K} = 494 \text{ J/kg} \cdot ^\circ\text{K}$

$$b = 6.60 \times 10^{-4} \text{ cal/g} \cdot ^\circ\text{K}^2 = 2.76 \text{ J/kg} \cdot ^\circ\text{K}^2$$

$$c = 0$$

A comparison of exptl with calcd values is shown in the Table:

Comparison of Specific Heats Generated with Best-Fits, Values of a and b with Experimental Values

T, °K	C _p , (expt), cal/g·°K	C _p , (best-fit), cal/g·°K
283	0.304	0.305
288	0.307	0.308
293	0.312	0.312
298	0.314	0.315
303	0.319	0.318
308	0.323	0.322
313	0.326	0.325
323	0.332	0.332
323	0.338	0.338
343	0.343	0.345

Trinitromelamine. See in Vol 8, M56-L

2,4,6-Trinitro-mesitylene. See in Vol 8, M62-R

2,3,3-Trinitro-2-Methylbutane.

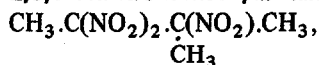

$\text{C}_5\text{H}_9\text{N}_3\text{O}_6$; mw 207.17; N 20.29%; OB to CO_2 -65.65%; mp 190° (decompn). Prepn is by nitration of 3-chloro-2-nitroso-3-methylpentane with concd nitric acid. The compd has an impact sensy < TNT and a power by BalMort of 106% TNT

Refs: 1) Beil 1, 141 2) Blatt, OSRD 2014 (1944)

2,4,6-Trinitro-3-Methylnitraminoaniline
(m-Amino Tetryl).

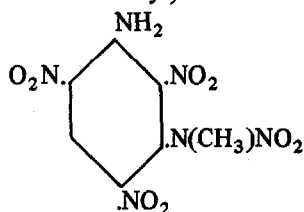

$\text{C}_7\text{H}_6\text{N}_6\text{O}_8$; mw 302.19; N 27.82%; OB to CO_2 -47.65%; cryst; mp 188° . Prepn is by treating 2,3,4,6-tetranitrophenylmethyl nitramine with ammonia. The compd has an ign (expln-Ref 2) temp of 201° when heated at $20^\circ/\text{min}$, and 190° when heated at $5^\circ/\text{min}$; an impact sensy of 43-45cm (Kast app using a 2-kg wt, 51cm for Tetryl); a thermal stab at 95° of "no decompn" in 30 eight-hr days (Ref 2), or stable for 185 days at 95° (Ref 3)

Refs: 1) Beil 13, 17 2) Blatt, OSRD 2014 (1944) 3) Urbański 3 (1967), 64-65

2,4,6-Trinitro-3-Methylnitraminophenetole.

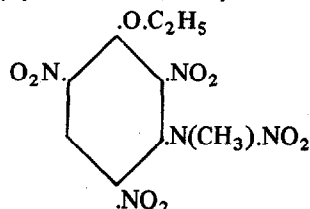

$\text{C}_9\text{H}_9\text{N}_5\text{O}_9$; mw 331.23; N 21.2%; OB to CO_2 -65.2%; cryst; mp $98-99^\circ$. Prepn is by heating

2,3,4,6-Tetranitrophenylmethyl nitramine (m-nitro Tetryl) with ethanol. The compd has an expln temp of 202° when heated at $20^\circ/\text{min}$, 192° when heated at $5^\circ/\text{min}$; an impact sensy of 16-19cm (Kast app, 10-kg wt, 14cm for Tetryl); a thermal stability at 90° of evolvn of nitrogen oxides after 2 hrs

Refs: 1) Beil 13, 425 2) Blatt, OSRD 2014 (1944) 3) Urbański 3 (1967), 64-65

2,4,6-Trinitro-3-Methylnitraminophenol
(Oxy Tetryl or m-Hydroxy Tetryl).

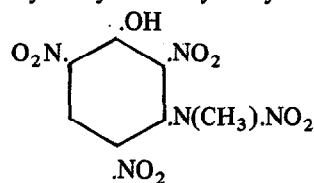

$\text{C}_7\text{H}_5\text{N}_5\text{O}_9$; mw 303.17; N 23.1%; OB to CO_2 -39.6%; mp 183° . Sol in w. Prepn is by hydrolysis of m-nitro Tetryl. The compd has an expln temp of 197° when heated at $20^\circ/\text{min}$, 188° when heated at $5^\circ/\text{min}$; an impact sensy of 30-33cm (Kast app, 10-kg wt, 50-51cm for Tetryl), this sensy represents a FI of 56% PA; a thermal stab at 95° of no change in 30 eight-hr days

The compd is a co-product in the prepn of Tetryl using monomethylaniline, since some dimethylaniline is present. On hydrolysis (in the process) m-hydroxy Tetryl is formed, leading to the formation of dangerously sensitive metallic salts. One such expl salt is the **Lead Salt**, which is so hygr it is considered of no practical value as an expl

Refs: 1) Beil 13, 425 2) Blatt, OSRD 2014 (1944)

2,4,6-Trinitro-3-Methylnitraminotoluene. See in Vol 8, M116-L & R under "Methyl Tetryl"

2,2,3-Trinitro-3-Methylpentane.

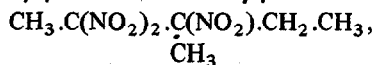

$\text{C}_6\text{H}_{11}\text{N}_3\text{O}_6$; mw 221.20; N 19%; OB to CO_2 -83.2%; cryst; mp $84-85^\circ$. Prepn is by nitration of 3-chloro-2-nitrosopentane with nitric acid. The compd has an impact sensy comparable to that of TNT and a power by BalMort of

86% TNT

Refs: 1) Beil 1, 150 2) Blatt, OSRD 2014 (1944)

2,4,6-Trinitro-monomethylaniline. See in Vol 8, M101-L & R

Trinitrophenol. See under "Picric Acid" in Vol 8, P285-R ff

α -Trinitrophenol-dinitroglycerin. See under "Glycerol- α -(2,4,6-trinitrophenylether)-dinitrate" in Vol 6, G109-R

2,4,6-Trinitrophenoxyethyl Nitrate. See in Vol 8, P236-L to P237-R

2,4,6-Trinitrophenylbutylnitramine. See under "Butyl Tetryl" in Vol 2, B379-R

2,4,6-Trinitro-m-phenylenediamine. See in Vol 8, P240-L & R

2,4,6-Trinitrophenylethyl nitramine. See under "Ethyl Tetryl" in Vol 6, E207-L & E319-R

2,4,6-Trinitrophenylguanidine. See in Vol 8, P242-L & R

2,4,6-Trinitrophenylhydrazine. See in Vol 7, H207-R

2,4,6-Trinitrophenylmethoxynitramine. See in Vol 8, P242-R

2,4,6-Trinitrophenyl-(1-Methylol) Propylnitramine Nitrate. See in Vol 8, P245-R

2,4,6-Trinitrophenylnitramine. See in Vol 8, P243-L

Trinitrophenylnitraminoethyl nitrate (Pentryl).

See in Vol 1, A425-L to A429-R

[2,4,6-Trinitrophenylnitramino]-Tris-(Hydroxymethyl) Methane Trinitrate.

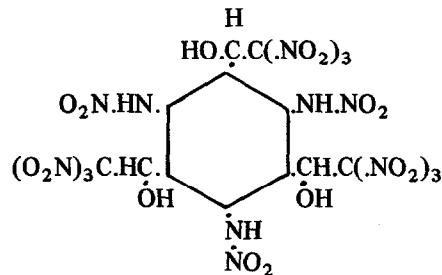

$C_{12}H_9N_{15}O_{24}$; mw 747.36; N 28.12%; OB to CO_2 -9.63%; yel cryst; mp 151-57° (decompn); d 1.80g/cc. Sol in ethyl acetate, dioxane, pyr, methyl nitrate and phenyl nitrate; sl sol in methanol, ethanol, eth, benz and chl; insol in CCl_4 , w, concd HCl and 20% aq Na hydroxide. Prepn is by nitration of (2,4-dinitrophenylamino)-tris-(hydroxymethyl)-methane with mixed acid at -10°. The yield is 78%. The compd has an activation energy of 13.07kcal/mole (Tetryl is 12.87kcal); expln-time temp range of 230°-21.8 to 39.2, 250°-3.0, 260°-1.4, 265°-1.3, 270°-1.1 and 275°-1.0 secs; ign temp of 158° (at a heating rate of 5°/min); and 169.5° (at 20°/min); impact sensy of 8 and 12cm (5-kg wt, Tetryl is 12 and 33cm); a power by Pb block of 26.2cc (Tetryl is 21.0cc); a thermal stab at 75° of yellowed in 3 days, and melted at 152.5° after 10 days; a thermal stab at 100° of yellowed in 3 hrs, produced N oxides in 14 hrs, and exhibited a mp decrease from 155° to 100° after 48 hrs exposure

Refs: 1) Beil, not found 2) J. Plucinski, ChemStosowana 7 (3), 461-70 (1963) & CA 61, 13116 (1965)

2,4,6-Trinitrophenyl- β,β,β -trifluoroethyl nitramine. See under "TFEt" in this Vol

Trinitropropyl Acetate.

$CH_3.C(=O).O-(CH_2)_2.C(NO_2)_3$, $C_5H_7N_3O_8$; mw 237.15; N 17.72%; OB to CO_2 -37.11%; liq; bp 62-64° at 2mm; RI 1.4432 at 19°. Sol in eth. Prepn is by refluxing trinitromethane with vinyl

acetate using BF_3 -eth as the catalyst in anhydrous eth as solvent for 2 hrs at 52° . Extraneous reactants are then extracted with w. The eth layer is dried, distilled, and redistilled to give the pure acetate in 40% yield. The inventors claim a stable expl withstanding ordinary mechanical and thermal shocks

Refs: 1) Beil, not found 2) P.O. Tawney & I.J. Schaffner, USP 3027403 (1962) & CA 57, 1142 (1963)

2,4,6-Trinitrostilbene. See in Vol 5, D1455-L & R

2,4,6-Trinitrotoluene. See under "TNT" in this Vol

2,4,6-Trinitrotolyl-3-methylnitramine. See under "Methyl Tetryl" in Vol 8, M116-L & R

2,4,6-Trinitro-1,3,5-triaminobenzene. See under "TATB" in this Vol

1,3,5-Trinitro-1,3,5-triazacyclohexane. Same as RDX or Cyclonite. See in Vol 3, C611-L to C630-L under "Cyclotrimethylenetrinitramine, Cyclonite or RDX", and an updated article under "RDX" in this Vol

2,4,6-Trinitro-1,3,5-Tris (Methylnitramino) Benzene (Tri-Tetryl or 2,4,6-Trinitro-1,3,5-Tri-methylnitraminobenzene).

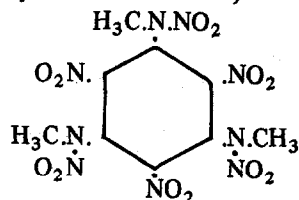

$\text{C}_9\text{H}_9\text{N}_9\text{O}_{12}$; mw 435.27; N 29%; OB to CO_2 -38.6%; white cryst (from acetic acid); mp 209.85° ; d 1.43g/cc. Sol in hot acetic acid. Prepn is by nitrating the condensation product of trinitrochlorobenzene with methylamine. The compd requires 0.386g of initiator for deton (Tetryl = 0.474g); the deton press of 50g in a

25cc monometric bomb is $613\text{kg}/\text{cm}^2$ (TNT = 420 and Tetryl = $580\text{kg}/\text{cm}^2$); the impact sensy is 18cm (TATB > 320cm); its Q_c^v is $2733.8\text{cal}/\text{g}$; the compd expls at $200-03^\circ$, and has a vac stab of 2.55cc of gas/48 hrs/15g sample at 100°

Refs: 1) Beil 13, 301 2) J.J. Blankama, Rec 23, 129 (1904) 3) Ibid 27, 40 (1908) 4) T. Urbański, ReczChem 17, 591-93 (1937) & CA 32, 1933 (1938) 5) Blatt, OSRD 2014 (1944) 6) L. Médard & M. Thomas, MP 35, 163 (1953) & CA 50, 14330 (1956) 7) F.J. Taylor, Jr, "Synthesis of New Explosives II, Derivatives of 1,3,5-Tribromo-2,4,6-Trinitrobenzene", NAVORD 4405 (1956) 8) Urbański 3, 66-67 (1967)

Tri (β -Nitroxyethyl) Ammonium Nitrate.

$(\text{O}_2\text{N.O.CH}_2.\text{CH}_2.)_3\text{NH.NO}_3$, $\text{C}_6\text{H}_{13}\text{N}_5\text{O}_{12}$; mw 347.24%; N 55.4%; OB to CO_2 -30%; cryst; mp 62.7° . The compd has a brisance by sand test of 0.4g crushing 44g of sand; an expln temp of 115° ; an impact sensy of 6" (2-kg wt); and a thermal stab of decompn in 44 hrs at 50°

Ref: 1) Beil, not found 2) Blatt, OSRD 2014 (1944)

Trinitroxylen (TNX). See under "Dimethylbenzene and Derivatives" in Vol 5, D1324-R to D1325-L

Trinitryl. Same as Glycerol- α -2,4,6-Trinitrophenyl Ether Dinitrate, or Dinitroglycerol Picrate

Trinol. Same as Trinitroanisole (see Vol 1, A450-L to A453-R)

Triogen. Same as Cyclotrimethylenetrinitrosamine (see Vol 3, C630-R to C632-R)

Trioxigen Difluoride. (Fluorine Ozonide). See in Vol 6, F135-L and the following Addnl Refs: 1) A.G. Streng, "The Oxygen Fluorides", ChemRev 63 (6), 607-24 (1960) & CA 60, 1318 (1964) [The author reports in this sum-

mary article that the calcd deton vel of the difluoride is about 550m/sec for the reaction $2O_3F_2$ (liq) \rightarrow $3O_2$ (gas) + $2F_2$ (gas); $\Delta H_{90^\circ K} = -6.94$ kcal. Deton occurs in contact with materials such as absorbent cotton, ammonia, liq methane, solid hydrazine, red P, ethanol (above the f pt of liq O_2), solid Br and I, and Tetryl. The article further reports that the difluoride does not react sponty with materials usually found in liq oxygen (rocket) systems, such as the metals and the plastics usually employed. An exception is polyethylene film which ignites 60 secs after exposure. Information is also presented on open cup testing using a 0.05% soln of the difluoride in liq oxygen. This testing revealed that either instantaneous explns or igns occur with unsym-diethylenetriamine, UDMH in JP-4 propint, pure UDMH, and pure JP-4. The results of hypergolic ign studies are also reported. It was found in tests conducted using a small-scale rocket motor that immediate hypergolic ign occurred with fuels such as ethanol, JP-4, unsym-diethylenetriamine and hydrogen] 2) J.C. Bailer et al, Eds, "Comprehensive Inorganic Chemistry", Vol 2, 966 (1973), Pergamon Press, Oxford [The compd is reported as being considered to be a *mixt* of dioxygen fluoride and tetraoxygen difluoride]

Tripentaerythritol Octanitrate (TPEON, Nitropenta).

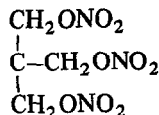
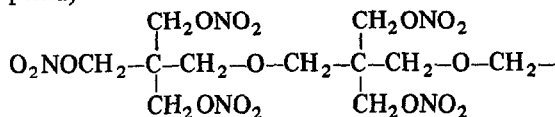

$C_{15}H_{24}N_8O_{26}$; N 15.3%; OB to CO_2 -35.0%; cryst; mp 82-84°; d (abs) 1.58g/cc, loading d (pressed at 60000psi) 1.565g/cc; sol in alc and chl, v sol in hot acet and hot benz, insol in w. Because of its relatively low mp, TPEON can be melted and poured, and can be used as a coating agent and sensitizer for Amm nitrate (Ref 6)

Prepn. It was first prepd by the reaction of

tripentaerythritol and 99% nitric acid at 0° to 10° by Wyler in 1945 (Ref 2)

A lab scale prepn (from Ref 7) follows: Twenty grams (0.054 mole) of nitration grade tripentaerythritol (TPE), 99% min purity, were slowly added with stirring, to 160g (2.55 mole) of 99% nitric acid at a temp of -25° to 0°. On an equiv wt basis, this quantity of 99% nitric acid corresponds to an excess of 6.3 times the TPE used. After addition of the TPE, the reaction mixt was stirred for about one hour at 0° to 5° and poured into eight times its volume of cracked ice. The product, when allowed to stand overnight, was crushed under w, filtered with suction, and washed copiously with w. It was then treated twice with about 5 times its wt of a 1% amm carbonate soln, stirred for several hours, filtered and washed with w until the final washings were neutral to litmus. The final product was washed successively with 50cc each of ethanol and ether. The material, dried in air, weighed 37.8g or 96% of theory based on TPE. It had a mp of 71° to 74°. Crystn of the crude TPEON from chl was found to be the most suitable method of obtaining pure TPEON *Brisance.* Measured by 200g Sand Bomb Test, 58.9g (TNT 48.0g)

Compatibility with other High Expls.

100° Vac Stab Test	NTN	PETN	RDX	TPEON
ml gas/40 hrs, 5g sample	0.14	2.15	0.39	2.45
ml gas/40 hrs, 5g sample of 50/50 TPEON/HE	1.89	1.71	2.32	-

Detonation Rate. 7650m/sec at d 1.56g/cc, pressed, charge diam 0.5", no confinement
Explosion Temp. 225° (5 secs)

Induction Periods for Thermal Initiation of TPEON

Temp, °C	Induction Time, secs
210	0
215	9.3
220	6.5
230	4.1
240	2.6
250	2.0

Friction Pendulum Test. Steel Shoe—Unaffected
Fiber Shoe—Unaffected

Heat of Combustion. 2632cal/g at const vol
Heat of Explosion. 1085cal/g (gas vol 762cc/g)
Heat Test, 100°C. % loss first 48 hrs — 1.15
 % loss second 48 hrs — 0.75
 expln in 100 hrs — none

Hygroscopicity. Gain or Loss in Wt, %

Time, hrs	% RH at 30°C		
	40	70	90
24	-0.008	+0.01	+0.04
48	-0.02	-0.01	+0.02
144	-0.04	-0.03	-0.02
192	-0.04	-0.02	-
216	-0.004	-0.01	+0.03

Impact Sensitivity. PicArsn app, 2-kg wt; 9" with 24mg sample; 10" with 12mg sample

Sensitivity to Initiation. 0.30g Pb Azide min detonating charge

Specific Impulse. 240 lb-sec/lb (calcd)

Vacuum Stability Test. 5g sample

ml gas/40 hrs	100°	100°	120°
	Crude	Pure	Specially Purified
	6.24	2.45	1.94

Uses. HE, and as possible plasticizer for NC (Ref 7)

Refs: 1) Beil, not found 2) J.A. Wyler (to Trojan Powder Co), "Preparation of Tripentaerythritol Octanitrate", USP 2389228 (1945) 3) K. Namba, J. Yamashita & S. Tanaka, "Pentaerythritol Tetranitrate", JIndExplosivesSoc (Japan) 15, 282-89 (1954) & CA 49, 11283 (1955) 4) E. Berlow, R.H. Barth & J.E. Snow, "The Pentaerythritols", ACS Monograph No 136, Reinhold, NY (1958) 5) J.J. LaMonte et al, "The Preparation and Explosive Properties of Tripentaerythritol Octanitrate", PATR 2490 (1958) 6) Urbański 2 (1965), 196-97 7) Anon, EngrgDesHndbk, "Explosives Series—Properties of Explosives of Military Interest", AMCP 706-177 (1971), 381-85

Trip Flare. See under "Flare" in Vol 6, F64-R & F65 (Table 1), and under "Pyrotechnics" in Vol 8, P506-L & R

Triphenylamine Perchlorate. $\text{Ph}_3\text{N.HClO}_4$; $\text{C}_{18}\text{H}_{16}\text{ClNO}_4$; mw 345.79; OB to CO_2

-189.7%; granular crystals; explds at 180°. Prep'd by treating triphenylamine with perchloric acid in cold CCl_4

Refs: 1) Beil 12, (166) 2) K.A. Hofmann et al, Ber 43, 1084 (1910)

Triplastita (Span). See under "Spanish Commercial Explosives of Nonpermissible Type" in Vol 3, C442-L

Triplastite. A plastic TNT expl, proposed by Rudeloff of Ger in 1908, consisting of TNT and Pb nitrate, made plastic by means of liq DNT gelatinized with collodion cotton (Ref 1). A formulation contg TNT with DNT 70, Pb nitrate 28.8 and collodion cotton 1.2% yielded a detonation velocity of 5030m/sec in a 26mm diameter pressed unconfined charge of d 1.45g/cc, vs 6400m/sec for TNT plus DNT at the same d
Refs: 1) J. Rudeloff, SS 3, 117-18 (1908) & CA 2, 2992 (1908) 2) Marshall 1 (1917), 558 3) Marshall 2 (1917), 495 4) Thorpe 4 (1940), 464

Triple Base Propellant. See under "Representative Solid Propellant Types and their Uses" in Vol 8, P406-R to P408-L

Triple Point in Blast. See under "Blast Effects Due to Reflected Shock Waves" in Vol 2, B182-L and Fig on B183

Tri-n-Propylaluminum. $\text{Al}(\text{C}_3\text{H}_7)_3$, $\text{C}_9\text{H}_{21}\text{Al}$; mw 156.24; OB to CO_2 -291.86%; colorl pyrophoric liq; fp -84°; d 0.820g/cc. Prepn is by reaction of propylene with isobutylaluminum. This compd is considered to be a dangerous fire risk as it ignites sponty in air
Refs: 1) Beil 4, 643 & [1024] 2) Sax (1968), 394 3) CondChemDict (1977), 892

1-Tris (Difluoramino) Methoxy-2,2,2-Trinitroethane (TMTNE or Tris (NF₂) methoxy trinitroethane). $(\text{NF}_2)_3\text{C.O.CH}_2.\text{C}(\text{NO}_2)_3$, $\text{C}_3\text{H}_2\text{F}_6\text{N}_6\text{O}_7$; mw 348.10; N 24.15%; OB to

CO₂ 0%; liq, mp -17 to -14.5°; bp 212° (est); d 1.54g/cc. Sol in 50/50 (vol/vol) chl-f-hexane. Prepn consists of reacting 15mg of urea, 5cc of acetonitrile, 2.7g of trinitroethanol and 5g of perfluoroguanidine by stirring together for 72 hrs at 23°. The excess perfluoroguanidine is removed and the mixt cooled to 0°. A blanket of F/He is then passed over the mixt for 1 hr while the temp is held at 23°. The solvent is vac distld off at -5 to 0°. The product is separated from the residue chromatographically by eluting with 50/50 (vol/vol) chl-f-hexane using a silica gel column. TMTNE is recovered from the early fractions of the chromatographic process, followed by removal of the solvent using vac distln

TMTNE shows a DTA exotherm at 150°; a 60° heat test for 100 hrs yields 2.0cc of gas/g; a shock (or impact) sensy of 3kg/inch; thermal stability values of 2.4cc of gas/g after 6 days at 60°, and 3.4cc after 1 addnl day at 90°

Ref 2 suggests that TMTNE be used as a high energy plasticizer in solid rocket proplnt compns
Refs: 1) Beil, not found 2) L.J. Engel et al, USP 3692837 (1972) & CA 77, 151449 (1972)

Tris-[X,X-Dinitro-4-Methyl-Phenyl]-Methane (or Hexanitro-4,4',4''-trimethyltritan).

CH[C₆H₂(NO₂)₂.CH₃]₃, C₂₂H₁₆N₆O₁₂; mw 556.44; N 15.11%; OB to CO₂ -115.02%; yel prisms; mp 280°. Prepn is by nitration of 4,4',4''-trimethyltritan with fuming nitric acid for 12 hrs. The compd detonates with brisance when heated above its mp

Ref: Beil 5, 714

Tris-[Hydroxymethyl]-Acetaldehyde and Salts.

Tris-[Hydroxymethyl]-Acetaldehyde.

OHC.C.(Hg.OH)₃, C₂H₄O₄Hg₃; mw 693.83. The compd is known only in the form of its salts, some of which are expl:

Chloratrimercuryacetaldehyde [Chloratotrimerk-
uraldehyde (Ger)].

H
O:C.C.Hg.O.ClO₂, C₂HO₅Hg₃Cl;



mw 742.25; OB to CO₂ 1.08%; white powder; d 2.995g/cc when compressed at 1200kg/cm². Sl

sol in w. Prepn is by passing pure acetylene thru an aq suspension of Hg (ic) chlorate. The compd is not sensitive to friction but will expld violently when in contact with flame or concd sulfuric acid (Refs 1 & 3). Its brisance by Pb plate test is comparable to MF; power by Trauzl Pb block is only 55.5% that of MF (2g gave 15.3cc at d 2.995g/cc vs 25.6cc for MF at d 4.43g/cc) (Ref 4)
Nitratomercuryacetaldehyde.

H
O:C.C.Hg.O.NO₂, C₂HNO₅Hg₃;



mw 720.81; N 1.94%; OB to CO₂ 1.11%; light grey powder. Prepn is by passing acetylene thru a filtered soln of yel mercuric oxide in 30% nitric acid-w mixt for 2 hrs at 18°. The compd explds on heating (Refs 1 & 2)

Perchloratotrimercuryacetaldehyde.

H
O:C.C.Hg.O.ClO₃, C₂HO₆ClHg₃;



mw 758.26; OB to CO₂ 3.17%; cryst; mp, explds mildly on heating. Moderately sol in w. Prepn is by passing acetylene thru an aq suspension of Hg (ic) perchlorate. The compd is not sensitive to friction or shock, ignites more quickly than "smokeless powder" (Ref 3, p 2003); power by Trauzl test indicates that the compd is more powerful than the analogous chlorato compd (2g gave 18.3cc vs 15.3cc for the chlorato compd), but only 65.5% as powerful as MF; it is very unstable, decompd on storage even at RT

Refs: 1) Beil 3, 607 & (217) 2) K. Hofmann, Ber 31, 2787 (1898) 3) K. Hofmann, Ibid 38, 2001-03 (1905) 4) L. Wöhler & O. Matter, SS 2, 203, 244, 265 (1907)

[Tris (hydroxymethyl) Amino]-Methane Tri-nitrate (or 2-Amino-2-hydroxymethyl-1,3-propanediol trinitrate).

C[CH₂.O.NO₂]₃NH₂, C₄H₈N₄O₉; mw 256.16; N 21.88%; OB to CO₂ -49.97%; yel liq; RI 1.492 at 22°. Prepn is by nitration of [tris-(hydroxymethyl) amino]-methane with 90% nitric acid at 0°. The compd is unstable even at RT, hence it is considered to be unsuitable for use as a mil expl

Refs: 1) Beil, not found 2) H. Aaronson,

"Study of Nitration Products of Alkylolamines",
PATR 1412 (1944)

Tris (Hydroxymethyl) Nitromethane (Trimethylolnitromethane, 2-(Hydroxymethyl)-2-nitro-1,3-propanediol or 2-Nitro-2-(hydroxymethyl)-1,3-propanediol). $[\text{HO}\cdot\text{CH}_2\cdot]_3\text{C}\cdot\text{NO}_2$, $\text{C}_4\text{H}_9\text{NO}_5$; mw 151.12; N 9.27%; OB to CO_2 -79.41%; cryst (from ethyl acetate + benz); mp 172° , 195° , 214° (separate values). V sol in alcohols and w (220g/100cc at 20°); sl sol in benz and other hydrocarbons. Prepn is by reacting trioxymethylene with nitromethane. The compd has a Q_c of 507.8cal/mole. Minnick (Ref 4) suggests usage of the compd as a fuel in an expl slurry for small bore-hole blasting operations. Thus, a mixt of Amm nitrate 72.2, w 10, resin balloons (phenol-formaldehyde) 2, tris-(Hydroxymethyl) Nitromethane 15, and guar gum 0.8% is reported as having a deton rate of 16696ft/sec
Refs: 1) Beil 1, 520, (276), [596] & {2345} 2) L. Médard & M. Thomas, "Determination of Heats of Combustion . . .", MP 35, 155-73 (1953) & CA 49, 11284 (1955) 3) R.E. Laine, USP 3325549 (1967) & CA 68, 68464 (1968) 4) J.J. Minnick, "Thickened Slurried Explosive for Small-Bore Hole Blasting Operations", USP 3409485 (1968) & CA 70, 21469 (1969) 5) H.S. Vierk & W.A. DenAdel, GerP 1910458 (1969) & CA 72, 54736 (1970) 6) Merck (1976), 1251 (No 9419)

Tris (Methylnitraminomethyl) Amine.
 $[\text{CH}_3\cdot\text{N}(\text{NO}_2)\cdot\text{CH}_2\cdot]_3\text{N}$, $\text{C}_6\text{H}_{15}\text{N}_7\text{O}_6$; mw 281.28; N 34.9%; OB to CO_2 -76.9%; prisms (from boiling chl); mp $115-16^\circ$. Sol in acet and ethanol; v sl sol in eth; insol in w. Prepn is by condensation of methylnitramine, formaldehyde and ammonia. The yield is 57%. The compd has a deflgn temp of 315° ; hygry at 25° of -9.6% (at 90% RH) and +3.1% (at 100% RH); a 50% pt impact sensy of 87cm (Bruceton No 3 app, 5-kg wt); wt loss by International heat test at 75° of -0.4%; power by BalMort of 107% TNT; thermal stab at 135° of "not acid" and no expln in 300 mins; and a vac stab at 100° of 1 cc gas/5g sample in 48 hrs
Refs: 1) Beil 4, 568 2) Blatt, OSRD 2014 (1944)

Trisol. Ger & Swiss for 2,4,6-Trinitroanisole, described in Vol 1, A450-L to A452-R
Ref: R. Meyer, "Explosives", Verlag Chemie, NY (1977), 356

Tris (oxymercuri) acetaldehyde Perchlorate.

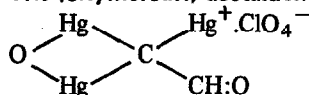

$\text{C}_2\text{HClHg}_3\text{O}_6$; mw 758.24; OB to CO_2 & HgO +4.22%; white solid; sensitive to percussion and friction (Ref 2). Prepd by passing acetylene into a soln of Hg oxide in perchloric acid (Ref 2). One g of the salt was able to initiate TNT, PA, TNB and other high expls (Ref 4). Power by Pb block expansion test: 0.2g gave a vol of 18cc vs 25.6cc for Pb Azide (Ref 3)
Refs: 1) Gmelin, Syst Nr 34, Teil A-2 (1962), 857 2) J.A. Nieuwland & J.A. Maguire, JACS 28, 1025 (1906) 3) L. Wöhler & O. Matter, SS 2, 247 (1907) 4) Ibid, SS 2, 268 (1907)

Tris (Thionitrosyl) Thallium. $(\text{SN})_3\text{Tl}$, $\text{N}_3\text{S}_3\text{Tl}$; mw 342.58; unstable solid. Decompd by hot w into Tl_2SO_3 and ammonia. Prepn is by reacting tetrasulfur tetranitride in liq ammonia with thallos nitrate to yield $\text{Tl}(\text{NS})_3 \cdot \frac{1}{2}\text{NH}_3$, which in vacuo at 48° yields the desired compd. The thionitrosy compd expls with great ease when either shocked or heated
Refs: 1) Gmelin, not found 2) K. Wade & H.J. Banister, "Aluminum, Gallium, Indium and Thallium", J.C. Bailer et al, Eds, "Comprehensive Inorg Chem", Vol 1, Pergamon Press, Oxford (1973), 1162 & CA 83, 90198 (1975)

Tris (2,2,2-Trinitroethyl) Orthoformate (or Tri-2,2,2-trinitroethanol methane).
 $\text{HC}[\cdot\text{O}\cdot\text{CH}_2\cdot\text{C}(\text{NO}_2)_3]_3$; $\text{C}_7\text{H}_7\text{N}_9\text{O}_{21}$; mw 553.23; N 22.79%; OB to CO_2 10.21%; cryst. Sol in liq nitroparaffins. CA Registry No [14548-59-5]. Prepn is by reacting 2,2,2-trinitroethanol with chl and C tetrachloride in the presence of ferric chloride

Ref 2 claims that soln of the compd in nitromethane in a 3:1 ratio gives a stable high performance liq expl with the following characteristics: d 1.52g/cc, expln vel 8060m/sec and a

limiting diam of < 10mm, while NG comparatively has 1.59g/cc, 7500m/sec, and < 10mm, respectively. Again, with nitromethane as solvent, a satd soln of the compd is reported by Ref 3 as having a deton vel of 7375m/sec, an impact sensy of over 50cm (5-kg wt) and a sp grav of 1.5325 at 20°

Refs: 1) Beil, not found 2) S. Fujihara et al, JapP 74-13313 (1974) & CA 81, 108119 (1974) 3) K. Shiino et al, "Liquid Explosives. 1. Nitro-paraffin Solutions of Trinitroethanol Ortho-ester", KogyoKayaku 35 (3), 113-20 (1974) & CA 85, 194924 (1976)

Tritex 2. Trade name for a powder form blasting agent of the Nitrocarbonitrate (NCN) type (AN based) distributed in the USA by Hercules Inc. Its d is 1.16g/cc, and wt strength 55%

Ref: R. Meyer, "Explosives", Verlag Chemie, NY (1977), 309

Trithioborate Rocket Fuels. The prepn of alkyl thioborates is covered in the ref, and their use is described for rocket fuels which are hypergolic with nitric acid. Me₃BS₃ was made by adding BCl₃ over 3 hrs at 10° reflux temp to a flask contg MeSH and NaSMe, each in ratio of 3 moles/mole BCl₃. The reaction mix was re-fluxed for 4½ hrs at 10°, and then raised to room temp. The pressure was released and the mixt fractionated at ambient pressure. The lowest boiling overhead fraction was refluxed for 8 hrs at subatm pressure, and then fractionally distld. Et₃BS₃ was prepd similarly. The authors compare hypergolic activity for several fuels with nitric acid from 70% concn to white fuming nitric acid

Ref: A. Zletz & D.R. Carmody, USP 2970428 (1961) & CA 55, 11852 (1961)

Tritolite and Tritolitol (Ital). See Vol 3, C627-R

Tritolo. Ital for TNT. See under "Italian Explosives and Related Items" in Vol 7, I180-R to I181-L

Tri-p-tolylamine Perchlorate.

(p-MeC₆H₄)₃N.HClO₄; C₂₁H₂₂ClNO₄; mw 387.87; OB to CO₂ -202.1%; granular crysts; explds at 180° (Refs 1 & 3). Prepd by the addn of perchloric acid to a soln of the amine in acetic acid, followed by evapn of the solvent (Ref 3)

Tri-p-tolylaminium Perchlorate.

(p-MeC₆H₄)₃N⁺.ClO₄⁻; C₂₁H₂₁ClNO₄; mw 386.87; OB to CO₂ -200.6%; violet-blue needles from chl; mp 123°; explds on further heating (Refs 2 & 4). It was prepd by the interaction of Ag perchlorate, I, and tri-p-tolylamine in cold eth (Ref 4)

Refs: 1) Beil 12, (415) 2) Beil 12, [494] 3) K.A. Hofmann et al, Ber 43, 1085 (1910) 4) E. Weitz & H.W. Schwechten, Ber 59, 2313 (1926)

Tritonal. A compn contg TNT 80 and flaked Al 20% was developed and standardized in the USA during WWII. It can be melt loaded and was used in bombs for its blast effect

Origin. The addition of Al to increase the power of expls was proposed by Escales in 1899 and patented by Roth in 1900 (GerP 172327). Some WWII studies, directed towards establishment of the optimum amount of Al in the TNT/Al system, showed that (1) the blast effect increased to a maximum when the Al content was 30% (Ref 4); the brisance, as measured by the Sand Test, passed thru a maximum at about 17% Al (Ref 1); in Fragmentation Tests, no maximum was observed, additions of Al causing a decrease in efficiency over the entire range from 0 to 70% Al (Ref 2); and (2) the rate of detonation of cast charges was continuously decreased by additions of Al up to 40% (Ref 5). For all practical purposes it was concluded that the addition of 18-20% Al to TNT improved its performance to a maximum. This conclusion was in agreement with that of Brit makers who measured performance of aluminized TNT mixts based on extensive Pb Block Test data (Ref 3)

Properties of 80/20 Tritonal:

Molecular Weight	81
Oxygen balance to CO ₂ , %	-77
to CO, %	-38
Density (Nominal Cast), g/cc	1.71 to 1.78
(Theoretical Max), g/cc	1.793

Blast (Relative to TNT):

Air:	
Peak Pressure	110
Impulse	115
Energy	119
Air, Confined:	
Impulse	130
Underwater:	
Peak Pressure	105
Impulse	127
Energy	119
Underground:	
Peak Pressure	117
Impulse	127
Energy	136

Booster Sensitivity (min charge):

Pb Azide	0.30g vs 0.26g for TNT
Diazodinitrophenol	same as TNT
Tetryl	same as TNT

Brissance or Power (% of TNT):

Ballistic Mortar	124
Plate Dent Test	93
200 Gram Bomb Sand Test	100
Fragment Velocity	91

Compressive Strength (load rate 0.05 inches/min):

Temperature, °F:	-80	-40	73	125	160
Stress at Rupture, psi:	4534	3835	2129	1495	1002
Compression at Rupture, %:	0.53	0.56	0.32	0.18	-
Mod. of Elasticity, psi x 10 ⁻³	1253	1275	1146	1345	-
Work to Prod. Rupture, ft-lb/in ³ :	1.42	1.17	0.29	0.14	-

Detonation Rate:

Configuration of Specimen	Density (g/cc)	Detonation Velocity (m/sec)		
		High	Low	Avg
0.5" x 0.5" x 6"	-	-	-	-
1.0" x 1.0" x 6"	1.78	6223	5929	6056
1.5" x 1.5" x 6"	1.77	6527	6491	6506
2.0" x 2.0" x 6"	1.77	6587	6468	6522

Explosion Temperature:

Seconds	°C
0.1	610
1	520
5 (decomps)	470
10	465

Friction Pendulum Test:

Steel Shoe	Unaffected
Fiber Shoe	Unaffected
Heat of Combustion, cal/g	4480
Heat of Explosion, cal/g	1770
Hygroscopicity, % at 30°C & 90% RH	0.00

Impact Sensitivity, 2-kg wt:

BuMines App, 20mg sample	85cm
Pic Arsn App, 16mg sample	13in

Impact Strength:

Temp, °F	-80	-40	73	125	160
Charpy, inch-lbs	1.42	1.45	1.37	1.35	1.42
Izod, inch-lbs	-	-	1.28	-	-

Linear Coefficient of Thermal Expansion:

Temp Range, °C	Coefficient, in % x 10 ⁻³ /°C
-50 to -20	4.21
-20 to 20	4.53
20 to 50	6.37
50 to 65	7.92

Rifle Bullet Impact Test:

	% (5 trials)
Explosions	60
Partials	0
Burned	0
Unaffected	40

Sensitivity to Set-Back Pressure (psi) at 160°F:

Probability of Reaction	Pressure
0.1%	86300
50%	93500
99.9%	101300

Shear Strength:

Temperature, °F	-80	-40	73	125	160
Stress at Rupture, psi	974	811	724	521	524

Specific Heat (cal/gm/°C):

	d = 1.74g/cc
At -5°C	0.230
At +20°C	0.305

Tensile Strength (Load Rate 0.05 inch/min):

Temperature, °F	-80	-40	73	125	160
Stress at Rupture, psi	153	271	277	177	74
Elongation at Rupture, %	0.01	0.02	0.03	0.045	-
Mod. of Elasticity, psi x 10 ⁻³	1769	1328	1540	645	-
Work to Prod. Rupture, ft-lb/in ³	.001	.002	.004	.004	-

Thermal Conductivity (cal/sec/cm/°C):

At °C & d 1.73g/cc	0.0011
--------------------	--------

Torsional Shear (Load Rate 36°/min):

Temperature, °F	73
Stress at Rupture, psi	236
Mod. of Elasticity, psi	150000

Vacuum Stability Test:

Temperature, °C	120	130	140	150	160	170	180
Ml gas from 5g sample	0.26	0.27	0.34	0.44	0.56	1.48	11 ⁺
40 hrs	—	—	—	—	—	—	—
8 hrs	—	—	—	—	—	—	1.67

Note: The above properties of 80/20 Tritonal were taken from Refs 7, 9 & 10

As metallic Al is insoluble in liq TNT, 80/20 Tritonal does not begin to melt until the mp of TNT is reached. It has a heat of combustion value of 4480cal/g at const press, as compared to 3590cal/g for TNT. The thermal conductivity of Tritonal at 0° is twice that of TNT. Like TNT, it undergoes considerable expansion on melting and contraction on freezing. The solubility characteristics of Tritonal are those of TNT, and it is essentially nonhygroscopic

The chemical reactivity of Tritonal is that of TNT and Al. In addition, in the presence of moisture, the TNT and Al undergo slight reaction with the evolution of gas. This is not of practical importance, because of the very slight hygroscopicity of TNT and the fact that any moisture present is driven off by heat during the manufacture of Tritonal

Although the friction pendulum test shows no measurable difference in sensitivity between Tritonal and TNT, impact tests indicate Tritonal to be somewhat more sensitive to impact than TNT and less so than Tetryl. The rifle bullet impact test value for Tritonal is more similar to that of Tetryl than that of TNT. The expln temp test value of Tritonal (470°) is almost identical with that of TNT

The brisance of Tritonal is 100% of that of TNT, as judged by sand test values, but plate dent tests indicate it to be only 93% and fragmentation tests of shell charges show it to be but 91% as brisant as TNT. The rate of detonation of cast Tritonal is approx 97% that of cast TNT. The heat of expln of Tritonal is 60% greater than that of TNT, but Tritonal is only 124% as powerful, as measured by the ballistic pendulum test. When tested for blast effect, Tritonal has relative peak pressure and positive impulse values of 113 and 118%, respectively, of those for TNT

As Tritonal has lower or equal vacuum stability test values (to 150°) as TNT, Al and TNT do not react at that or lower temps. Tritonal, therefore, has the same stability as TNT, if free from moisture. Deterioration in the presence of moisture is not

serious, probably being limited by the formation of a layer of oxide on the surface of the particles of Al that prevents or retards further reaction. Tritonal, like TNT, can undergo exudation if stored at elevated temps, but this tendency is less than that of TNT because of the presence of 20% by wt of metallic particles that tend to hold only exudate by surface tension and prevent it from coalescing and exuding (Ref 8)

Preparation. 80/20 Tritonal is manufd from TNT and grained Al. The TNT and Al are run slowly thru separate chutes into a steam-heated melting kettle equipped with a stirrer, which is kept in motion while the ingredients are being added. Heating and mixing are continued until all the TNT is melted, the temp is greater than 81°, and the fluidity of the mixt is considered satisfactory. The Tritonal is then loaded by pouring into bombs, with at least the same precautions and techniques used in the melt-loading of TNT (Ref 8)

Analytical. The composition of a sample of Tritonal is determined by extracting a weighed sample with benzene, drying and weighing the residue. The loss in wt represents TNT and the wt of residue represents Al (Ref 8)

Refs: 1) W.R. Tomlinson, Jr, "Develop New High Explosive Filler for AP Shot", PATR 1290 (1943) 2) Ibid, PATR 1380 (1944) 3) Anon, "The Effect of Aluminum on the Power of Explosives", Armament Res Dept, Brit Rept AC-6437 (Explosives Rept 577/44) (1944) 4) W.B. Kennedy, R.F. Arentzen & C.W. Tait, "Survey of the Performance of TNT/Al on the Basis of Air-Blast Pressure and Impulse", OSRD 4649, Division 2, Monthly Report No AES-6 (25 Jan 1945) 5) L.S. Wise, "Effect of Aluminum on the Rate of Detonation of TNT", PATR 1550 (1945) 6) K.S. Warren, "Study of Effect of Moisture on 80/20 Tritonal", PATR 1560 (1945) 7) Anon, "Allied and Enemy Explosives", APG, Aberdeen, Md (1946), 88-89 8) Anon, "Military Explosives", TM 9-1910 (1955), 184-86 9) Anon, EngrgDesHndbk, "Explosives Series, Properties of Explosives of Military Interest", AMCP 706-177 (1971), 386-

90 10) T.S. Costain & R.V. Motto, "The Sensitivity, Performance and Material Properties of Some High Explosive Formulations", *PATR* **4587** (1973), 50-51 11) R.J. Slape, J.A. Crutchner & G.T. West, "Some Sensitivity and Performance Characteristics of the Explosives H-6 and Tritonal", Tech Rept **AFATL-TR-74-104**, Eglin AF Base (1974) 12) J.E. Ablard, "H-6 Explosive History and Properties", **NAV-SEA-03-TR-044**, Naval Sea Systems Command (1977)

Tritorite. See under "Ghinijonet" in Vol 6, G73-R

Tri-Trinal. Ger WWI expl charge for small-caliber shells. It was a compressed mixt of 2p TNT (*Tri*) with 1 p Trinitronaphthalene (*Trinal*) and was used with a booster of compressed PA
Refs: 1) Naoúm, *Expls* (1927), 62 2) Davis (1943), 158

Tri-1,1':3',1"-2,4,6-Trinitrophenyl) (or 2,2',2", 4,4',4",6,6',6"-Nonanitro-1,1':3',1"-Terphenyl).

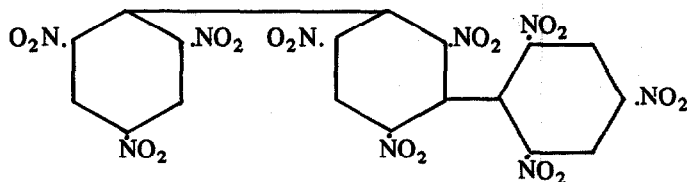

$C_{18}H_5N_9O_{18}$; mw 635.32; N 19.85%; OB to CO_2 -51.63%; cryst; mp 440-50° (decompn). Sol in toluene and hot acetonitrile. Prepn is by refluxing Cu dust with picryl chloride and dichlorotrinitrobenzene in MNB with stirring for 25 mins. The crude product contg syrup is dissolved in toluene, refluxed, filtered hot, re-filtered thru silicic acid, evapd to dryness, dissolved in toluene, again refluxed, filtered, and finally purified by chromatography on silicic acid/Celite 535 and recrystd from acetonitrile. The terphenyl has a brisance greater than TNT (even after heating at 770°F for 30 mins), an impact sensy of 39cm, and is non-volatile at 210°
Refs: 1) Beil, not found 2) J.C. Dacons, *USP* 3755471 (1973) & *CA* **80**, 49963 (1974)

Triumph Safety Powder. See under "Courteille Powder" in Vol 3, C550-R

Trivilene. One of the names for Dinitrotoluene, when used for coating cannon powder grains
Ref: Anon, "Smokeless Powder Cannon Ingredients", Hercules Powder Co Test Method S-50 (Feb 27, 1936 revised Oct 1, 1940)

Trirogen. Ger for a pourable mixt of RDX and TNT

Ref: R. Meyer, "Explosives", Verlag Chemie, NY (1977), 309

Trixyl. Ger for 2,4,6-Trinitro-m-xylene
Ref: L. Wöhler & O. Wenzelbeg, *AngChem* **46**, 173 (1933)

Trizen. Ger for Styphnic Acid (Trinitroresorcinol). See Vol 5, D1276-R

Ref: R. Meyer, "Explosives", Verlag Chemie, NY (1977), 253

Trizinal or Trizinat. Ger Lead Styphnate. See Vol 5, D1277-L ff

Trobach Priming Mixture. Patented in 1890 in Ger, consisted of Ba picrate 70, K chlorate 15 and salts of pyridine nitrate 15%

Ref: Daniel (1902), 776

Troisdorf Powder. One of the earliest types of Ger smokeless small arms powder, consisting of gelatinized NC with/or without nitrates, and manufd by the Rheinisch Westfalische Aktiengesellschaft. This powder was used not only by the Ger army but was also exported into Belg and other countries. It was also manufd in Engl under the name of Chilworth Smokeless Sporting Powder (see Vol 2, C179-L)

Ref: Daniel (1902), 776

Trojamites. Trade name for Nitrostarch based low density industrial expls distributed in the USA by the Trojan Powder Co:

Trojamite	Density, g/cc	Weight Strength, %
A	1.17	68
B	1.0	68
C	0.88	68

Ref: R. Meyer, "Explosives", Verlag Chemie, NY (1977), 309

Trojan Explosive. A Nitrostarch based expl used by the USA during WWI and to a limited extent in WWII in demolition charges. It contained Nitrostarch 40, Na nitrate 37.7, Ba nitrate 20, oil 0.8, and stabilizer (diphenylamine or Ca carbonate) 1.5%; grey solid; pressed in ½ and 1-lb blocks at d 1.6g/cc

Its properties are: ballistic strength, 96% TNT; brisance, 37.7g sand crushed vs 43g for TNT; ignition temp, 195°; impact sensitivity (PicArns app with 2-kg wt), 8", rifle bullet test, 90% detonations from .30 cal bullets fired at 90' distance; and velocity of deton, 6100m/sec vs 6900m/sec for TNT

It is sol in acet; hygroscopic and unstable in storage. On prolonged storage it might become insensitive and cause misfires. When stored at 50° it decompd after about 1 year; some spontaneous detonations were reported on storage at tropical temps. It corrodes some metals, such as Fe and Cu

Trojan Explosive was used, despite its drawbacks, as a demolition expl in preference to Dynamites because it was less sensitive than the NG Dynamites of its era. It is no longer being manufd

Ref: Anon, "Allied and Enemy Explosives", APG, Aberdeen, Md (1946), 147-48

Trojel and Trojel EZ-POR. Trade names of water gel blasting agents distributed in the USA by the Trojan US Powder Co. Trojel is sensitized by Nitrostarch; Trojel EZ-POR by TNT. Density, 1.46g/cc; wt strength, 65% (Ref 2)

Ref 1 states that Trojel WS-7 is a slurry expl which is sensitized with wet Nitrostarch and uses both amm and Na nitrate as its oxidizers. The use of Nitrostarch gives this slurry relatively high

deton velocity and pressure, though the available energy is lower than aluminized slurries. Its properties are: d 1.22g/cc; deton vel 4923m/sec; deton pressure 12.0GPa; and energy (theoretical) 3360kJ/kg

Refs: 1) H.H. Reed, "A Review of Explosives Used in Explosive Excavation Research Laboratory Projects Since 1969", Misc Paper E-74-6, US Army Engineer Waterways Expt Station, Livermore (1974) 2) R. Meyer, "Explosives", Verlag Chemie, NY (1977), 309

Tropylium Perchlorate.

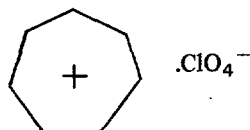

$C_7H_7ClO_4$; mw 190.59; OB to CO_2 -109.1%; cryst solid; explds at 230° (Ref 2); CA Registry No [25230-72-2]. It was prepd by the addition of 30% perchloric acid to tropylium bromide in aq soln (Ref 2). The dry salt is friction sensitive; on one occasion a 20g sample detond violently while being stirred (Ref 3)

Refs: 1) Beil, not found 2) M.E. Vol'pin et al, DoklAkadN 112, 264 (1957) & CA 51, 10257 (1957) 3) P.G. Ferrini & A. Marxer, AngChem 74, 488 (1962) & CA 57, 10091 (1962)

Trottil or Tol. Russ for TNT. See under "Russian Explosives and Related Items" in this Vol

Trotten Powder. One of the earlier "progressive burning" smokeless powders. Its grains were cylindrical with a single perforation

Ref: Daniel (1902), 653

Trotyl. Ital, Fr, Russ, Ger, Swedish and Swiss name for TNT

Tschirner Explosives. The following expl compns were patented in 1880: a) A paste formed by treating a mixt of Picric Acid 52, K

chlorate 43 and rosin 15% with a rosin solvent such as benz or petroleum. After shaping the expl, the solvent was evapd (Refs 1, 2, 4 & 5).

b) 5p K chlorate was worked into an intimate mixt with 1 p pulverized TNT and 1 p mineral tar. The resulting stiff dough was not affected by moisture (Ref 3)

Refs: 1) Cundill (1889) in MP 6, 105 (1893)
2) Daniel (1902), 777 3) Colver (1919), 693-94 4) Perez Ara (1945), 222 5) Guia, Trattato 6 (1959), 393

Tsel'tit. Russ pre-WWI blasting expl contn NG (gelatinized with NC), K nitrate, K oxalate and woodmeal

Ref: Anon, SS 12, 409 (1917)

Tungsten (Wolfram). W; at wt 183.85; at no 74; valences 6, 5, 4, 3 & 2; naturally occurring isotopes: 180 (0.2), 182 (25.8), 183 (14.2), 184 (30.6) & 186 (29.2%); artificial radioactive isotopes: 173-179, 181, 185 & 187-189; steel-grey to tin-white metal with a body centered cubic structure having two forms: the α -form which exists stably above 700° and the β -form which exists to 700° and is sponty air pyrophoric when powdered (Refs 1, 2, 7, 15, 17, 32, 45, 49, 50 & 55)

Occurrence. A rare metal, W comprises about 1.5ppm of the earth's crust. The commercially viable ores are wolframite [(FeMn)WO₄], ferberite (FeWO₄), hubnerite (MnWO₄), powellite [Ca(WMo)O₄] and scheelite (CaWO₄). Ore deposits are found in China (75% of the world's deposits), Burma, Korea, Bolivia, Portugal and the USA. Here, deposits in California, North Carolina, Nevada, Nebraska, Colorado, Idaho and Texas contain 0.5 to 2.0% WO₃ (Refs 45, 49 & 55)

History of Discovery. In 1779 Peter Woulfe examined the mineral now called wolframite and reported a hitherto unknown substance. Scheele, in 1781, found that a new acid could be made from tungsten (circa 1758 nomenclature for scheelite). Scheele and Bergman suggested the possibility of obtng a new metal by redn of this acid. The deElhuyar brothers found an acid in

wolframite in 1783 that was identical to the acid tungsten (tungstic acid) of Scheele, and in that year they succeeded in obtng the element tungsten by redn of this acid with charcoal (Refs 45, 49 & 55)

Preparation. The ores are usually digested with aq caustic and then acid is added to form a tungstic acid ppt. The tungstic acid is converted to amm para tungstate crysts with amm hydroxide. At 400-500° the para crysts become tungstic oxide. Heating the oxide in the presence of hydrogen produces either blue W₂₀O₅₈ or brown WO₂. Further redn with hydrogen at 800 to 1000° produces pure W powder. Another prepn procedure involves aluminothermic redn of the oxides (Refs 45, 49 & 50)

Fabrication Techniques. Although W is used primarily in ordn as a fuel in powdered form, the powder (available from prepn) can be arc-melted and cast into ingots which are processed for a variety of purposes using the usual metal-working techniques. Thus, the cast ingots can be forged, extruded, rolled, swaged, spun and drawn into any desired shape at <1485°. This is termed "hot-cold-working" because of the thermal environment used which is below the usual metal working level. It has been found that at usual machining temps, W pieces stress, chip, and crack. Therefore, the metal is machined at <0° and ground by electrical discharge procedures to avoid deterioration of the work piece. Additionally, expl forming of W sheet is of interest for making asymmetric shapes. This forming is done with an expl in a hydraulic medium on one side of the specimen on a die, and vacuum on the other side (that is, the W work piece is in the cavity). To provide a high enough temp, molten Al is used as the hydraulic medium (Ref 49). Experimentation in this area using W powder has shown that the most efficient rate of compaction of the W powder in expl forming is 3cm/sec, with a ratio of the expl wt to that of the compacted W powder wt being 0.43 (Ref 59)

Properties.

W is soluble in a mixt of concd nitric acid and hydrofluoric acid; v sl sol in nitric acid, sulfuric acid or aqua regia; insol in hydrofluoric acid or

Table 1
Physical Properties of Tungsten (from Ref 49)

Property	Value
Melting point	3410°C
Boiling point	5930°C
Debye temperature	305°K
Density, metal powder	2.0–4.8g/cm ³
sintered at 1200°C	10.0–12.0g/cm ³
sintered at 3000°C	17.0–18.5g/cm ³
swaged rod	17.0–19.2g/cm ³
drawn wire	19.3g/cm ³
Specific heat, 0°C	0.03–0.05cal/g-°C
2600°C	0.06cal/g-°C
Latent heat of fusion	45cal/g
Latent heat of vaporization	1180cal/g
Vapor pressure, 1727°C	3×10^{-15} atm
3410°C (mp)	5.4×10^{-6} atm
4227°C	5.6×10^{-3} atm
5727°C	0.9 atm
Thermal expansion, linear	$L = L_0 [1 + (4.28t + 0.00058t^2) \times 10^{-6}]$ t = °C
Thermal conductivity, 0°C	0.40cal/(cm)(sec)(°C)
1227°C	0.28
1827°C	0.40 (porous metal)
2227°C	0.50 (porous metal)
Electrical resistivity, 20°C	5.6 microhm-cm
927°C	30.2
1827°C	59.0
2727°C	90.4

Table 2
Mechanical Properties of Tungsten (from Ref 49)

Property	Value
Tensile strength, sintered ingot	18,000 psi
swaged rod	500,000–215,000 psi
drawn wire	250,000–600,000 psi
annealed wire	150,000 psi
High-temperature tensile strength, 20°C	430,000 psi
0.028 inch diameter wire 800°C	200,000 psi
1500°C	50,000 psi
2800°C	5,000 psi
Yield Strength	Approximately 90% or more of the tensile strength
Rupture strength, 900°C	36,000 psi (1 hr) 35,000 psi (10 hr) 32,500 psi (100 hr)
1200°C	25,000 psi (1 hr) 22,000 psi (10 hr) 15,000 psi (100 hr)
Brittle-ductile transition	100–250°C (wrought) 350°C (recrystallized)
Ductility	0–4% elongation (brittle when recrystallized)
Elongation, 200°C	0% (recrystallized)
400 –1000°C	55% (recrystallized)
Reduction in area, 200°C	0.5% (recrystallized)
700°C	75%
Modulus of elasticity	12.8 x 10 ⁶ pdi (for sintered rod) 53 x 10 ⁶ psi (for well-worked wire)
2400°C	32 x 10 ⁶ psi
Modulus of rigidity, room temperature	23.0 ± 0.2 x 10 ⁶ psi (annealed)
1600°C	18.7 x 10 ⁶ psi
Compressibility coefficient	1.67 x 10 ⁻³ per ton/inch (smallest value for all the metals)
Hardness, sintered bar	255 Vickers
swaged bar	400–480 Vickers

K hydroxide; can be fused using a mixt of Na hydroxide plus Na nitrate (Refs 7, 49, 50 & 55)

W, in the finely divided state, is either spontaneously pyrophoric or reacts with gentle heating with a range of oxidants: Air, Br trifluoride, Br pentafluoride, Cl trifluoride, fluorine, I pentafluoride, nitryl fluoride and oxygen difluoride (Refs 42 & 57)

Uses. A survey of pertinent literature to-date has revealed the following Ordn applications for W, plus studies examining the thermally initiated reactions involved in these applications

Explosive Applications.

Coding Expls for Identification after Expln. Livesay (Ref 33) claims that the addition of W particles in uniform particle size from 1 to 250 microns function as codifying devices for post-expln identification purposes. Examples are given for incorporation into Dynamite and small-arms proplnts

Expl Initiation Studies. According to Kur-bangalina (Ref 18), the critical diam for deton of Nitromethane changes with the addition of 1 micron (d 19.3g/cc) W powder. Thus:

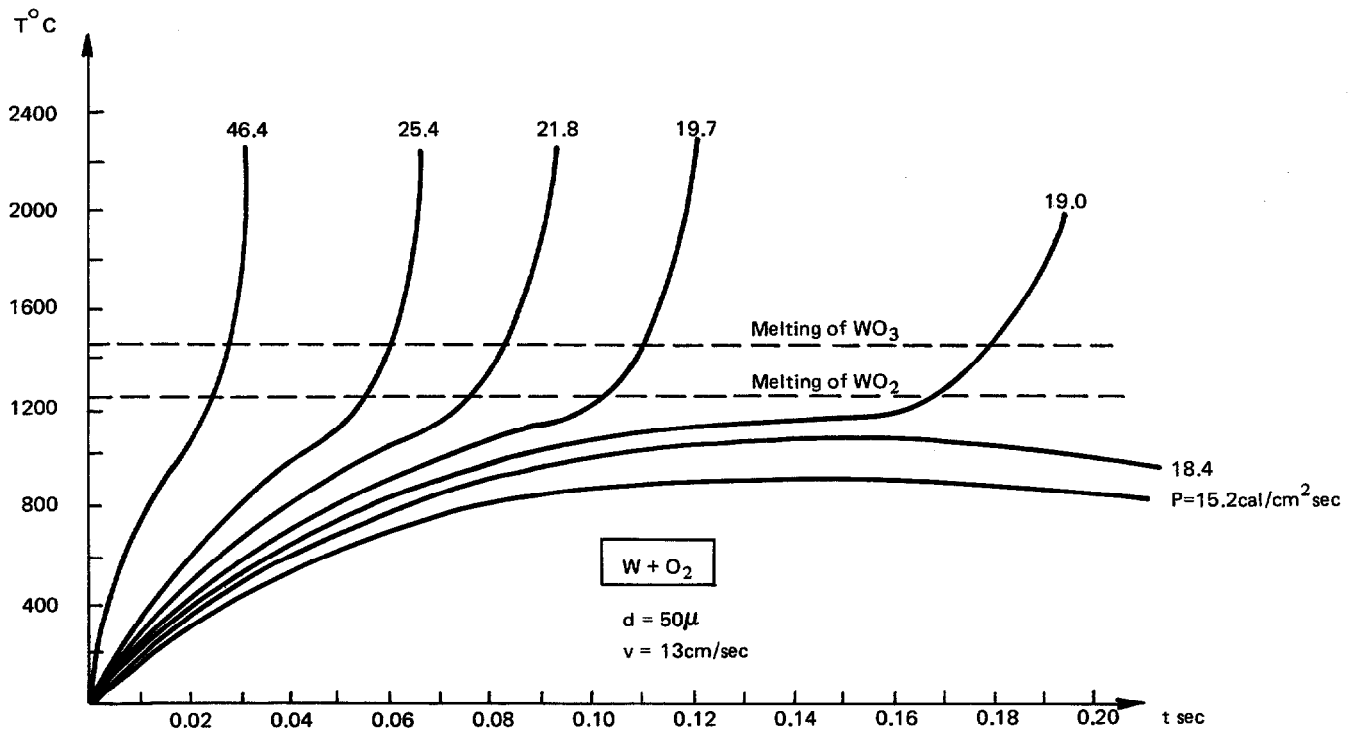

Fig 1 Thermogram of Tungsten Ignition in Oxygen

Wt % W	Critical Diameter, mm
0	12.0
10	4.0
20	2.5
30	2.0
40	2.2
50	2.4
60	8.0

The author concludes that the particles create additional hot spots which serve to shorten time-to-deton because a heterogeneous detonation front results. The effect of the degree of dispersion of the particles is shown by a parabolic plot of the critical diameter in mm versus the wt % of W powder data. From the parabolic shape of this curve the author further concludes that the more particles present beyond a certain point, the less efficient the individual hot spots become and, ergo, the greater the critical diameter for detonation. Indeed, extension of the plotted data beyond the measured data for over 60 wt % W indicates a substantial increase in critical detonation diameter over pure Nitromethane. This effect is attributed to the formation of heat sinks by the W particles in

the detonation front (or inefficient hot spots), or complex W-nitromethane reactions which were beyond the scope of the study. Derzhavets (Ref 19) studied the "hot centers" effect further using the addition of powdered W and organometallic compounds containing 30% W to solid RDX to explore critical charge diameter, initiating charge size and the effect on the distance of detonation transmission. He found that the additives are only effective for charges of high density or low porosity. Also, that there is a decrease in the minimum initiating charge required and critical charge diameter, but no effect on the distance of detonation transmission.

New Expl Compns. Weinland (Ref 21) suggests that W powder with a bulk density of $\leq 6\text{g/cc}$ be incorporated with a HE so as to form a high impulse generating explosive useful for projecting fragments at high velocity, moving metal objects without shattering them, and inclusion in effective shaped charges and wave-shaping devices. Thus, a mixture of equal weights of compound C-3 and 6-micron W particles was tested in 2" (inside diameter) x 6" mild steel cylinders having a 0.25" thick

wall, at d 4.17g/cc. A deton vel of 6049m/sec, fragment vel of 1268m/sec, and a charge to metal ratio of 0.564 were achieved. Using 100% C-3, the resp values are reported as: 1.6g/cc, 7625m/sec, and 1223m/sec. Similarly, a 75/25 Compn C-3/W of 1.1-micron particle size is reported as having a deton vel of 6550m/sec, and in "punch" charges, punched complete cylindrical plugs out of steel plate. The use of equal vols of 100% C-3 punched the same size holes, however, the plugs were fragmented and spalled

Propellant Applications.

Combustion Mechanisms. Merzhanov (Ref 38) studied the ignition of metal particles including W, in a stream of O_2 which was heated by an electrical resistance wire at constant power input in order to simulate a proplnt combstn environment. The power input was varied for a series of runs, resulting in a family of thermographs at different power levels (noted as cal/cm²-sec). Fig 1 is a plot of the data obtd using 50-micron diam cylindrical particles with coordinates of temp in °C vs time (t) in secs, resulting in ignition at the critical temp. The author concludes that W particulate ignition is defined by the melting of an initial film of intermediate product WO_2 , and not as a result of a self-accelerating temp increase by a thermal expln mechanism which occurs when the Friedman-Macek theory is valid

Jensen & Webb (Ref 43) examined the data predicting the extent of afterburning in fuel-rich exhausts of metal-modified double-base proplnt rocket motors so as to determine the amt of an individual metal which is required to suppress this afterburning. The investigatory means they used consisted of a series of computer codes. First, an equilibrium chemistry code to calculate conditions at the nozzle throat; then a nonequilibrium code to derive nozzle plane exit compn, temp and velocity; and, finally, a plume prediction code which incorporates fully coupled turbulent kinetic energy boundary-layer and nonequilibrium chemical reaction mechanisms. Used for all the code calcns were the theoretical environment of a static 300 N (67-lb) thrust std research motor operating at a chamber press of 3.5MNm⁻² (500psi), with expansion thru a conical nozzle to atm press and a mass flow rate

of 0.14kg/sec. Their calcns show that addn of 5 wt % W to the proplnt would result in marginal afterburning at 1550°K, and a 6% addn would lead to afterburning suppression

Ion Engines. Saunders (Ref 6a) reports successful usage of porous W platelets for ionizing the N_2 working medium in exptl ion-powered rocket engines. Thin, porous W platelets were developed by sintering compacted 1-micron powder at 2750°F for 20 hrs in a H_2 atm

New Proplnt Compns. Henderson and Hoglund (Ref 28) claim in their patent that addn of W to a gas generating compn will produce an electrophilic gas that is capable of obscuring the wake of a separately powered airborne vehicle from radar absorption or reflection by capturing the free electrons in its wake. Thus, when cured, a mixt of W 15, Amm perchlorate 28, W trioxide 40, carboxy-terminated polyester 11 and trimethylenetrinitrosamine 6% in grain form is reported as burning under a press of 1000psi at the rate of 0.23"/sec. In Schwarz's invention (Ref 29) high energy proplnts are claimed when W and Al are incorporated in low vol charges. Thus, an effective proplnt is reported as contg RDX 50, powdered Al 24, powdered W 24, and wax 2%

Pyrotechnic Applications.

Delay Compositions. The major use of W powder is as a fuel in delay compns. Earlier information on W-contg delay trains can be found in Vol 4, D872-R to D875-R, and in Vol 8, P512-R to P515-L. A compilation of tabulated data from Refs 10 (pp 282-86) and 41 (pp 21-24, 7, 8 & 10) is presented as Tables 3, 4 & 5

Tungsten delay compns were developed to satisfy the requirements for reliable, long burning times (\approx 40secs/inch). K perchlorate was added to the binary mixt of W/Ba chromate to increase the heat of reaction, increase ignitibility, and to insure propagation at low temps (see Table 5). Variation in the burning rate of a 55/10/35 Ba chromate/W/K perchlorate compn, loaded at 36000psi in vented bodies — as a function of W particle size — is shown in Table 6

Much of the work done on W delay compns by Werbel, Stirrat and Gifford (Refs 4 & 5) in the late 1950s and early 1960s seems to indicate that the

Table 3
Gasless Delay Compositions in Current Use
 (from Ref 41, p 21-8)

<u>Fuel, %</u>	<u>Oxidants, %</u>		<u>Inert Filler, %</u>
Tungsten	Barium Chromate	Potassium Perchlorate	Diatomaceous Earth
27 to 39	59 to 46	9.6	5 to 12
39 to 87	46 to 5	4.8	3 to 10
20 to 50	70 to 40	10	—

Table 4
Heats of Reaction of Tungsten in Inorganic
Mixtures Considered for Delays
 (from Ref 41, p 21-7)

	<u>$-\Delta H^\circ$</u>	<u>$-\Delta H^\circ/n$</u>
Silver Oxide	174.7	29.1
Silver Chromate	852.5	28.4
Barium Peroxide	137.5	22.9
Lead Chromate	469.1	15.6
Cuprous Oxide	68.2	11.4
Barium Chromate	50.3	8.4

Footnotes to Table 4:

$-\Delta H^\circ$ — heat of reaction

$-\Delta H^\circ/n$ — equivalent heat of reaction (heat of reaction per electron charge)

Table 6
Variations of Burning Rate due to Change in
Particle Size of Tungsten Delay Composition
 (from Ref 41, p 21-10)

<u>Tungsten Micron Size</u>	<u>Average Burning Rate, secs/inch</u>
4	9.0
8	17.2
15	28.1

Table 5
Burning Rates of Various Tungsten Delay Compositions
 (from Ref 10, p 282 & Ref 41, p 21-10)

<u>W</u>	<u>Ingredient, %</u>		<u>Nominal avg burning rate, secs/inch</u>	<u>Gas volume, cm³/g</u>	<u>Heats of reaction, cal/g</u>
	<u>BaCrO₄</u>	<u>KClO₄</u>			
85	—	15	1.6	—	—
80	—	20	2.5	—	304
28	62	10	48.6	8.5	—
30	60	10	31.2	10.4	—
32	63	5	28.7	3.3	—
35	30	35	24.1	—	—
40	47	13	5.9	—	346
50	40	10	7.8	4.3	305
65	20	15	3.0	2.1	—
70	10	20	7.3	1.6	—

Composition, parts			Nominal burning rates, secs/inch;									
			pressure, atmospheres, absolute									
BaCrO ₄	W	KClO ₄	0.00	0.06	0.13	0.40	1.0	19.0	36	72	172	
35	55	10	17.3	17.8	17.3	15.2	17.4	12.2	7.3	6.3	5.3	
35	55	12	22.2	19.0	19.2	16.8	18.0	15.1	12.3	10.3	8.3	

reliability of a delay is not only compn and particle size dependent, but also depends on the mechanical integrity of the pressed delay mixt column. Therefore, loading pressures in excess of 36000psi and the presence of a small spacer element in the delay column housing aids in environment survival under high "g" force loads. Integrity is enhanced by the use of a binder such as vinyl alcohol acetate copolymer (Ref 10, p 288)

Now, according to Weingarten (Ref 10, p 283-4) "... Compositions containing tungsten show an effect similar to other compositions with respect to pressures above atmospheric; i.e., the burning rate increases. The table above illustrates this for two compositions.

A composition consisting of W/KClO₄/BaCrO₄ (55/10/35), when loaded into the M-112 fuse housing at 36,000 psi with increasing weights of charge, gave the following results:

Wt Charge, mg	Nominal avg Burning Time, secs
500	1.20
1000	2.35
2000	4.31
3000	6.00
4000	7.62
5000	9.28
6000	11.82

The results indicate that the burning times are not exactly linear, but the columns appear to be burning a little faster with increasing length. This may be due to length of column needed to reach maximum burning velocity.

A storage study was conducted over a period

of a year on a composition consisting of W/BaCrO₄/KClO₄ (32/58/10) loaded into vented 40-mm tracer bodies. No failures in ignition or propagation occurred in any of the items tested. There does not appear to be any general trend in the results, either faster or slower burning at the end of the year, indicating that the composition may be considered to be stable. Given in the table below are the detailed test results

Addnl information on W-contg delays from 1970 to date is presented next

Combustion Parameters of W-Containing Delay Compositions. Zimmer-Galler (Ref 20) investigated the combstn processes of delay compns contg W, K perchlorate or Ba chromate and diatomaceous earth. She reports that an interaction between W and K perchlorate is the initiating step in the combstn process, and that the burning rate is controlled primarily by the thermal conductivity of the system. The temp profile technique she used for her investigation shows successively induction, reaction and cooling zones with no liq reaction zone. She concludes that heterogeneous decompn reactions of the oxidizing agent are involved in the burning process, and consequently, there is a pressure dependence of the burning rate (for example; 30secs/inch at 15psi and 19secs/inch at 1200psi, for a 30% W-contg compn)

Charsley et al (Refs 37, 47, 48, 51, 54, 56 & 59b), after years of investigation, report the following on the W-K dichromate delay compn system combstn processes; "... Binary mixtures with potassium dichromate are easily ignited and burn smoothly. Both temperature profile (Fig

Temperature	Relative humidity, %	Nominal avg burning time, sec; surveillance, mo.						
		0	0.25	1	2	3	6	12
Ambient	10	16.9	16.6	16.7	17.2	17.1	16.2	16.2
Ambient	75	—	16.6	17.2	16.8	17.6	21.6	18.6
71°C	Ambient	—	16.9	16.7	15.7	—	16.6	17.0 ..."

2) and DTA studies (Fig 3) show the presence of two main exothermic reactions. Potassium tungstate and chromic oxide have been identified in the final products and the reaction $W + K_2Cr_2O_7 = K_2WO_4 + Cr_2O_3$ in which the stoichiometric proportion of tungsten is 39%, is consistent with the maximum shown by the exothermicity data (Fig 4). The products from the first reaction stage are not well defined and only potassium chromate has been established unequivocally. A possible representation of the reaction might be $W + 2K_2Cr_2O_7 = WO_3 + 2K_2CrO_4 + Cr_2O_3$ which leads to the reaction

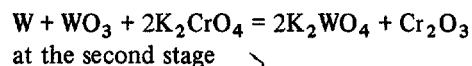

Subsidiary DTA experiments have shown that mixtures of tungsten, tungstic oxide and potassium chromate give an exotherm similar to the second reaction exotherm. However, this ternary mixture does not readily self-propagate combustion and the burning velocity of the binary mixture containing 50% tungsten-50% potassium dichromate can be reduced five fold by the addition of 50% of the ternary mixture. This lack of reactivity in the second stage is reflected in a broad ill-defined DTA peak . . .”

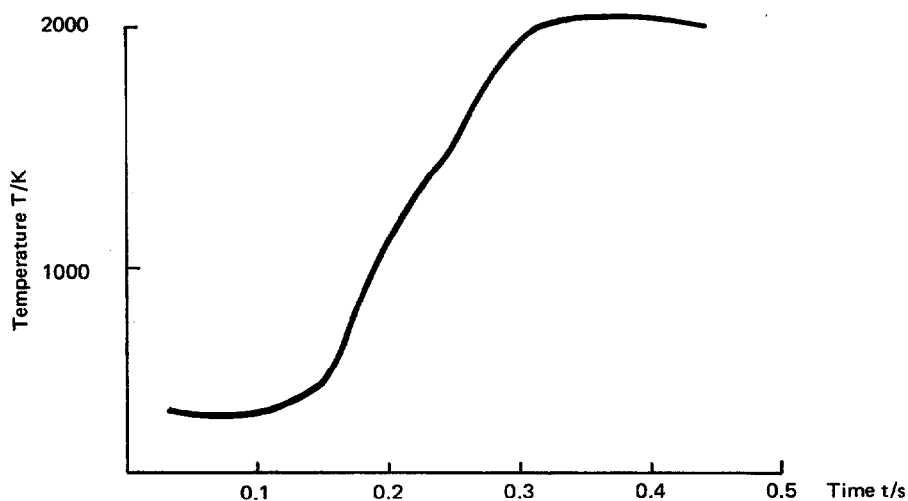

Fig 2 Temperature Profile for Tungsten (50%) – Potassium Dichromate (50%)

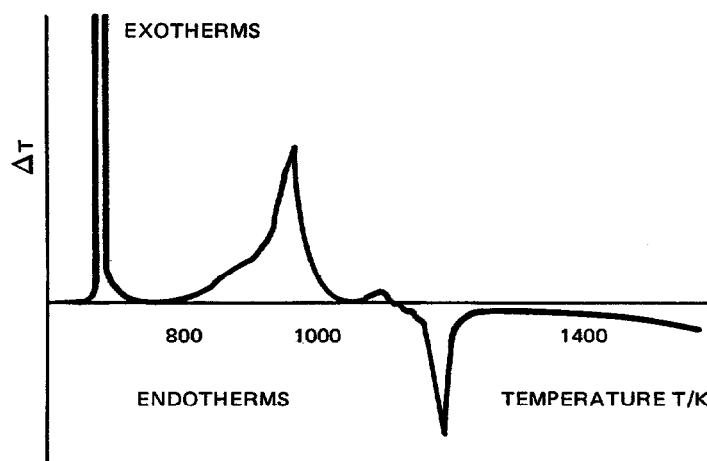

Fig 3 DTA Curve for Tungsten (50%) – Potassium Dichromate (50%)

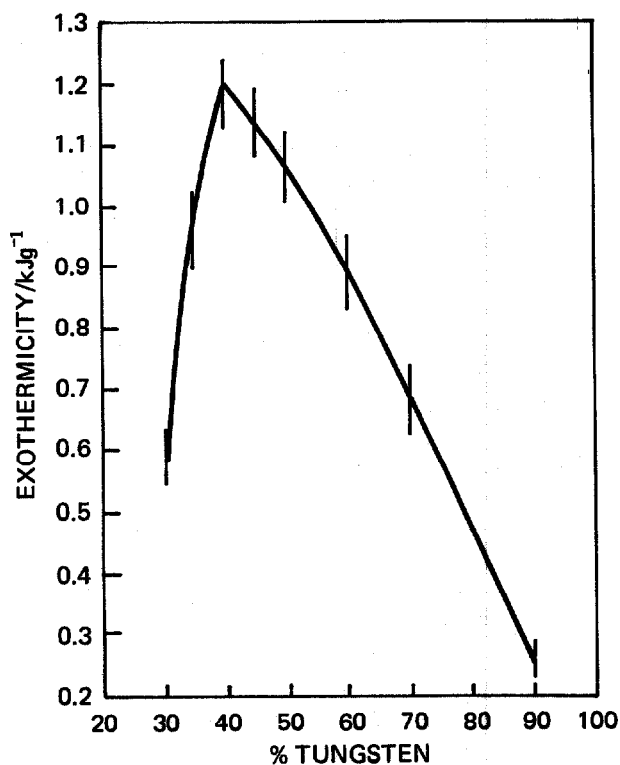

Fig 4 Exothermicity of the Ignition Reaction of the Tungsten-Potassium Dichromate System Determined by Quantitative DTA

Gilford and Taylor (Ref 59a) studied the W-Ba chromate-K perchlorate delay system using DTA, Expanded Thermal Gravimetric Analysis, IR, and TGA. They conclude from their data that the W becomes coated with K chloride during burning, thus inhibiting its oxidn, that the presence of K chloride in the system also increases the decompn rate of K perchlorate by catalytic effect and that mixts of W and Ba chromate do not react. From the last finding the authors suggest that the chromate acts primarily as a diluent. This conclusion, plus the known carcinogenic activity of hexavalent chromium compds, led the authors to consider a substitute for Ba chromate in W-contg delays. Among the feasible candidates are Al oxide, Cr oxide and Si dioxide

Nakamura et al (Ref 60) investigated the thermal oxidation reactions of W with various oxidants by measuring the temp at which each oxidation reaction occurs, measuring the burning

rate, and identifying the oxidation products. They found that the oxidation of W with atm O₂ to yield WO₃ occurs at 450 to 650°; with K perchlorate at 440 to 500°; and with Ba chromate at 900°. They report that the oxidation temp with K perchlorate is dependent on the mixture's compn, and is lower at lower ambient O₂ pressure. The authors also report that addn of Ba chromate to W-K perchlorate mixts results in a higher ign temp, and that the burning rate of this mixt is found to increase from 2.38 to 39.4mm/sec with a parallel increase of from 10 to 40 wt % in the amount of Ba chromate added. From examination of the products of this reaction they conclude that the principal reaction products of the mixt are K chloride and Ba tetraoxytungstate

Ignition Parameters of W-Containing Delay Compositions. The work of Farnell and Beardell (Ref 36) in simulating a transient flame contact or accidental ign of a W-contg delay system during the manufg process has produced the following information: using a W-K perchlorate-C₁₀Cl₁₂-Vinyl alcohol acetate resin (64/10/15/1%) non-compacted mixt, the time-to-ign in an open container when the mixt is wet with ethanol is reported as 99 secs, and when wet with acetone, 55 secs. In a closed bomb app, 50g of the delay compn ignited in 1.25 secs, generating a peak press of 150psi with a positive duration of over 3 secs. This same delay compn is also reported by the authors as having a DTA ign temp of 436° with a thermal conductivity of 0.0032 watts/cm²/°C

Rion and Dupont (Ref 44) examined the mode of detonating expl trains which can incorporate several std W-contg delays of either 0.6 or 2.8 sec duration. The techniques considered were electrical squib and percussion fuse. The relative merits of each system are discussed. They also present an exptl device for electrical ign delay time measurement. Charsley and Tolhurst (Ref 46) in their study of the 50/50 W-K dichromate delay system note that reaction between these constituents starts at 400° when the dichromate melts and contacts the W, producing yellow flames. They also found that when this mixt is heated rapidly to 380-400°; ignition occurs with a bright flash

Manufacture of W-Containing Delay Compositions. According to Harris (Ref 40), in the

manuf and storage aging of W-K dichromate delay systems, water uptake rates and subsequent wt losses on redrying indicate that the reaction of W powder with water is affected by the presence of K dichromate. He concludes that when the dichromate is present a passive layer may be formed on the W particles which prevents further reaction. The author recommends pretreatment of the W powder by boiling with K dichromate soln. He also concludes that the electrical leakage resistance of most pyrot constituents (including W) decreases greatly as the humidity increases because of absorption of water from the air during manuf. Further, a RH sufficiently high enough to enable the electrical charges to disperse may produce compns too moist for efficient functioning. He feels that the correct alternative is to use a stream of air ionized by the action of radioactive material

New or Improved W-Containing Delay Compositions. Rose and Zimmer-Galler claim in their patent (Ref 24) that the elimination or reduction of the effect of temp change on the burning rate of delay compns by addn of a heavy metal soap (at wt ≥ 25) to powdered mixts which, in general, contain W10-90, K perchlorate 4-15, diatomaceous earth 3-12%, and a secondary oxidizer such as a chromate, oxide or peroxide. Prepn of a delay compn consists of treating the delay constituent mixt with sufficient solvent at the correct temp for the soln and dispersion of the soap (this temp is approx 100° for Zn stearate). The resulting dough is mixed to the consistency of damp earth, then forced thru a 16-mesh US Standard sieve (1.18

mm) and dried for 48 hrs at 140°F. According to the inventors, the amt of soap required is detd empirically. Reported (in Table 7) are the burning rates and temp coeffs of three compns prepd by treating powdered mixts of W 35, Ba chromate 48.5, 49.0 and 49.5%, resp, with K perchlorate 10, diatomaceous earth 5 and Zn stearate 1.5, 1.0, and 0.5%, resp

Miller (Ref 35) reports on a Pb chromate-Ba chromate-W delay compn which is prepd by physical or meta-thetic coprecipitation techniques. By varying both the Pb-Ba ratio and W particle size, the delay can be made to burn at from 0.4 to 2.5secs/cm.

Brooks and Valenta (Ref 62) report on the development of reefing line pyrot delay cutters contg W-Viton delay compns. These cutters are used in mid-air retrieval systems for recovery of remotely piloted vehicles. The developed items operate under 2000g acceleration at from -100° to 160°F with time delays of 2.0 to 27 secs

Stability of W-Containing Delay Compositions. Rose (Ref 53) reports that stability testing has been accomplished on a W-Viton delay compn as part of an overall program to ascertain the stability of delay compns under various temp and humidity environments. The pertinent W-Viton delay was developed at NWC, China Lake for the 5"/RAP in a gun projectile igniter application program. The compn consists of W, Ba chromate, K perchlorate, Si dioxide and 1% added Viton. It is mixed using a Shock-Gel technique in which the Viton is first dissolved in acet and then pptd on the compn particles by addn of the non-solvent hexane. The compn is then rinsed with addnl hexane. The burn time range, according to Rose, is unknown at present. However, compns burning for as long as 30secs/inch and as quickly as 2secs/inch have been prepd. The author states that compns burning even faster and slower may be possible. He concludes the following relevant to the W-Viton compn: 1) W-Viton delays are remarkably stable in the compressed state at RT and at 200°F for time periods up to 12 weeks; 2) The delays will not withstand humid storage at 160°F/95% RH for five days. Propagation failures can occur as can be seen from the data in Table 8 3) W-Viton delay compns (per WS 12607) are stable in loaded units for time periods up to four years as can be seen from Table 9

Table 7
Effect of Varying Both the Zinc Stearate and Barium Chromate Content on the Burning Rate and Temperature Coefficient of a Tungsten Delay Composition
(from Ref 24)

Zn Stearate (Ba Chromate), %	Burning Rate secs/inch		Temp Coeff, sec/inch
	+71°F	-65°F	
	1.5 (48.5)	12.9790	
1.0 (49.0)	13.142	12.326	+0.0060
0.5 (49.5)	12.1479	12.7583	-0.00488

Table 8
Environment Surveillance of a W-Viton
Composition
 (from Ref 53)

Environment	Burning Rate, secs/inch	Success Rate
Ambient	28.568	18/18
-65°F	31.162	9/9
Humid	30.0512	3/10

4) W-Viton delay compns have better storage stability than Mn delay compns at RT and at temps of up to 200°F, as detd by surveillance of loaded cartridge activated and ignition devices

First Fire Compositions. A reduction of over 60% of formulation impact, friction and electrostatic sensy has been achieved according to

Table 9
Evaluation of Mk279 Mod Igniters Contg W-Viton
Delay Compn over a Four Year Timespan
 (from Ref 53)

Year	1973	1977	
Temp, °F	Igniter Delay Time, secs	Change, %	
20	24.23	24.075	-0.64
70	22.94	22.919	-0.09
120	21.72	21.744	+0.11

Carrazza et al (Ref 26) by replacement of both the first fire (DP-973) and the intermediate compns (DP-906) used in the M49A1 Trip Flare Assembly with a W/Ba chromate/K perchlorate/VAAR (65/24/10/1%) compn (DP-1886). Comparison of the parameters of interest are shown in Table 10

Table 10
Comparison of Sensitivity and Physico-Chemical Characteristics of DP-906, DP-973 and DP-1886
 (from Ref 26)

	DP-906	DP-973	DP-1886
Sensitivity			
Friction: Steel Shoe	Complete Burning	Complete Burning	No Action
Fiber Shoe	Complete Burning	No Action	No Action
Impact, PA, inches	12	24	33
Electrostatics, min joules	0.0023	0.025	0.749
Heat of Reaction, cal/g	515	463	249
Gas Volume, cc/g	3.1	29.2	16.1
Ignition Temperature, DTA	560°C	680°C	421°C
Closed Bomb Data			
Time to Peak, msec			
360ml bomb	—	388	198
52ml bomb	—	396	166
28ml bomb	112.4	15.8, 110 Two Peaks	100-125
Peak Pressure, psi			
360ml bomb	—	14	9.3
52ml bomb	—	57	37.9
28ml bomb	44.4	74, 96 Two Peaks	100-125

Notes:

DP-906 Current standard intermediate charge 90/10 barium chromate/boron

DP-973 Current standard first fire 90/10/1 barium chromate/boron/VAAR

DP-1886 New intermediate and first fire charge 65/24/10/1 tungsten/barium chromate/potassium perchlorate/VAAR

Incendiary Compositions. According to Ref 27 (p 3-48) a typical small arms incendiary mixt can include W. The appropriate mixt, the IM-112, is comprised of Mg-Al alloy (50/50) 45, Ba nitrate 50 and W powder 5%

Projectile Tracers. Several devices using various shapes of plate W as a thermal radiation emitter have been developed which, when the associated thermal compn is ignited, act as projectile tracers. One such device is that of Bouisse and Villey-Desmeserets (Ref 22) who claim in their patent that a cover plate of W will act as a covert emitter when the plate is heated to incandescence. In operation, two charges are used. The first charge (Fe₂O₃ 84, Al 13 and Si 18p) when ignited heats the W plate to incandescence; subsequently, the second charge (Al 80 & CaSO₄ 130p) ignites and destroys the plate. Thus, the device becomes a visible tracer as the projectile moves down-range. In another invention, that of Stetter et al (Ref 39), the emitter device is comprised of a thin-walled W tube hermetically sealed at one end with a Cu plug and contg a high temp compn consisting of Pb₃O₄ 66, Si 24, FeSi 6 and Fe₂O₃ 2%. When ignited by a fuse, the compn heats the W cylinder to incandescence, thereby acting as a radiator to trace the in-flight movement of guided missiles

Smoke Compositions. Allen (Ref 14, pp 17, 66, 79 & J-7) reports on the use of a mixt of Cs nitrate/Al/W (66/18/16%) loaded into a Loki type rocket vehicle under 10000psi press (d 0.11 to 0.12lb/in³ at 70°F), to act (upon ign) as an ion and smoke generator, with a burn time of approx 30 secs, for high altitude (27000 to 32000 ft) rocket tracking purposes

Toxicity. No definite or serious toxic effects have been evidenced on the inhalation or ingestion of W (Ref 13)

Specification. There are two USA military specifications covering powdered tungsten. They are presented next in chronological order of promulgation:

The earliest and still current USA military specification (Ref 3) for tungsten powder details the following requirements (Table 11):

The most recent USA military specification (Ref 30) details the following requirements for tungsten powder to be used in pyrot applications: 1) Tungsten, 99.9% min, as calcd by subtracting the quantity of impurities found (see

Table 11

Tungsten, % min ^a	99.00
Oxygen, % max ^b	0.50
Iron, 1% max ^c	0.10
Non Volatile Residue, % max ^d	0.10
Density, g/cu inch ^e	35 to 65

Footnotes to Table 11:

- a—gravimetrically as pure WO₃ after removing impurities by acid soln, cinchonine chelation, Na carbonate fusion and ign of the residue
 b—gravimetrically by loss-in-wt techniques after reduction of any oxides to water using gaseous hydrogen at 900–950° for 1 hr
 c—gravimetrically as Fe₂O₃ after acid soln of the sample, Na carbonate fusion of the W to a water sol salt, pptn of Fe as FeS, filtrn off of the FeS, and ign of Fe residue to Fe₂O₃
 d—gravimetrically to constant wt after ign over a free flame for 1 hr, followed by furnace treatment at 600° with passage of dry HCl gas over the sample
 e—Apparent density determination employing a Scott Volumeter

Table 12), and verified as the major constituent spectrographically; 2) Table 12 shows the max allowable percentages of metallic impurities in the tungsten, detd spectrographically in accordance with ASTM procedure E158 (Spectrochemical Computations):

Table 12
Maximum Allowable Metallic Impurities
in Tungsten Powder

Element	Percent
Aluminum	0.002
Cobalt	0.002
Chromium	0.004
Copper	0.002
Iron	0.025
Magnesium	0.001
Manganese	0.001
Molybdenum	0.040
Nickel	0.001
Lead	0.001
Silicon	0.003
Tin	0.001

3) Oxygen content, 0.08% max, detd in accordance with ASTM procedure E159 (Hydrogen Loss of

Copper, Tungsten and Iron Powders)

4) Allowable avg particle size range, detd in accordance with ASTM procedure B330 (Method of Test for Average Particle Size of Refractory Metals and Compounds by the Fisher Sub-Sieve Sizer):

Tungsten Powder Type	Avg Particle Size, microns
Type I, agglomerated	4.5±0.5
Type II, as supplied	4.5±0.5
Type III, lab milled	4.2±0.6

5) Table 13 shows the required particle size distribution, detd in accordance with ASTM procedure B430 (Particle Distribution of Tungsten Metal Powder by Turbidimetry):

There are several compds of W which exhibit expl and/or pyrophoric behavior:

Triphenyl Tungsten Tris (Phenyl Lithium)-Tris (Diethyl Ether). $(C_6H_5)_3W \cdot 3LiC_6H_5 \cdot 3(C_2H_5)_2O$; $C_{48}H_{60}Li_3O_3W$; mw 875.81; violet crysts. Sol in ethanol and other org solvents; decompd by w. According to Ref 9, it is sponty flammable in air
Tungsten Azide Pentabromide. WN_3Br_5 ; mw 625.40; N 6.72%; cryst. Sol in CCl_4 . Prepn is by dissolving WBr_6 in CCl_4 to form a slurry, and then adding BrN_3 . The compd is termed an expl by Refs 11 & 42

Tungsten Azide Pentachloride. WN_3Cl_5 ; mw 403.15; N 10.43%; cryst. Sol in CCl_4 . Prepn is by dissolving WCl_6 in CCl_4 to form a slurry, and then adding CIN_3 . The compd is termed an expl by Refs 11 & 42

Written by H. L. HERMAN

Refs: 1) Gmelin, Syst No 54 (1933)
 2) Mellor, Vol 11 (1943), 729 & 851
 3) Anon, Military Specification, "Tungsten Powder", MIL-T-13827 (7 Dec 1954) 4) B. Werbel & W.M. Stirrat, "Development of a Pyrotechnic Delay for the Vigilante 37mm T324 HE Cartridge", PATR 2672 (1960) 5) M. Gilford & B. Werbel, "Development of a Thirty-Second Delay Switch", FRL-TN-12, PB 148662 (1960) 6) Ellem, "Modern Pyrotechnics" (1961), 88, 145 6a) N.T. Saunders, "Experimental Method of Producing Porous Tungsten for Ion Rocket Engines", NASA TND 864 (1961) (AD 258265) 7) Anon, EngrgDesignHndbk, "Military Pyrotechnics Series—Part Three—Properties of Materials Used in Pyrotechnic Compositions", AMCP 706-187 (1963) 8) G. Brauer, Ed, "Handbook of Preparative Inorganic Chemistry", Vol 2, Second Edn, Academic Press, NY (1965), 1417 & 1622 9) B.E.

Table 13
Distribution, Weight Percent

Particle Size Distribution, microns	Type I Agglomerated As Supplied		Type II De-Agglomerated			
	Min, %	Max, %	As Supplied		Lab Milled	
			Min, %	Max, %	Min, %	Max, %
0-5	6	18				
5-10	22	38				
10-15	20	35				
15-20	12	25				
20-25	0	25				
0-1			0	2	0	5
1-2			1	5	1	11
2-3			5	14	10	20
3-4			10	20	15	27
4-5			11	23	15	27
5-6			11	21	10	20
6-7			8	17	4	12
7-25			Balance	Balance	Balance	Balance

- Douda, "Air Reactive Compounds . . .", **RDTR No 71**, NAVAMDEP, Crane (1966) 10) G. Weingarten, "Pyrotechnic Delay Systems", in F.B. Pollard & J.H. Arnold, Jr, "Aerospace Ordnance Handbook", Prentice-Hall, Englewood Cliffs (1966), 282-84; table 285 11) K. Dehincke, "Reactions of Halogen Azides", *AngChem* **6**, (3), 240-46 (1967) & *CA* **66**, 104639 (1967) 12) Ellern (1968), 201 ff & 416 13) Sax (1968), 1214 14) E.F. Allen, Jr, "Design, Development and Flight Tests of Chemical Release Payloads for Upper Atmosphere Research", **AFCRL-68-0587**, Space Data Corp, Phoenix, Contract AF 19 (628)-5125 (1968) 15) J.P. Mugler, Jr, "Space Environmental Effects on . . . Metallic Materials", 11th EffSpaceEnvironMaterSocAerospMaterProcess-EngrgNatlSympExhib, St Louis, 55-61 (1967) & *CA* **68**, 96379 (1968) 16) R.Kh. Kurbangalina, "Dependence of the Critical Diameter of Liquid Explosives on the Solids Content", *ZhPriklMekhTekhFiz* (4), 133-36 (1969) & *CA* **71**, 126697 (1969) 17) J.R. Gibson & J.D. Weber, "Handbook of Selected Properties of Air- and Water-Reactive Materials", **RDTR No 144**, NAVAMDEP, Crane (1969), 25-26 18) R.Kh. Kurbangalina, "Dependence of Critical Diameter of Liquid Explosives on Content of Powders", **LA-TR-20-8**, translated by H. Dahlby from *ZhPriklMekhTekhFiz* (4), 133-36 (1969) & *CA* **71**, 126697 (1969) 19) A.S. Derzhavets, "Increased Susceptibility of Explosives to a Detonation Impulse", *TemostoikieVzryvchatyevshchestvalkhDeistvieGlubokikhSkvazhinakh*, 37-52 (1969) & *CA* **73**, 16938 (1970) 20) R. Zimmer-Galler, "Combustion of Tungsten Delay Powders", *WestStatesSectnCombustnInstnt*, **WSS/CI-68-19** (1968) & *CA* **72**, 80990 (1970) 21) C.E. Weinland, "High Impulse Explosives Containing Tungsten", USP 3528864 (1970) & *CA* **73**, 122077 (1970) 22) J.M. Bouisse & F. Villey-Desmeserets, "Pyrotechnic Tracer for Projectiles and Missiles", *FrP* 1601136 (1970) & *CA* **74**, 89334 (1971) 23) F.R. Taylor et al, "Pyrotechnic Illuminant Compositions", USP 3664898 (1972) & *CA* **77**, 90789 (1972) 24) J.E. Rose & R. Zimmer-Galler, "Pyrotechnic Delay Composition Containing a Heavy Metal Soap", USP 3726730 (1973) & *CA* **79**, 7573 (1973) 25) Anon, Military Specification, "Tungsten Delay Composition", **MIL-T-23132A-** (1) (3 Jan 1973) 26) J.A. Carrazza et al, "Development of a Safer Intermediate and First Fire Formulation for the M49A1 Surface Trip Flare", *PATR* **4636** (1974) 27) Anon, *Enggr-DesHndbk*, Military Pyrots Series, Part Four, "Design of Ammunition for Pyrotechnic Effects", **AMCP-706-188** (March 1974) 28) C.B. Henderson & R.F. Hoglund, "Electrophilic Gas Generating Compositions", USP 3779008 (1973) & *CA* **80**, 135497 (1974) 29) W. Schwarz, "High Energy Secondary Explosives", *GerP* 2248218 (1974) & *CA* **81**, 65771 (1974) 30) Anon, Military Specification, "Tungsten Powder (for Pyrotechnics)", **MIL-T-48140(1)**, (14 May 1974) 31) Not used 32) E.G. Kayser & C. Boyars, "Spontaneously Combustible Solids—A Literature Survey", **PB 244046** (1975) 33) R.G. Livesay, "Coding Explosives for Identification after Explosion", *GerP* 2343774 (1975) & *CA* **83**, 100322 (1975) 34) N.N. Bakhman & I.N. Lobanov, "Effect of Heat Conduction Elements on the Rate of Combustion", *FizGoreniyaVzryva* **11** (3), 501-06 (1975) & *CA* **83**, 118048 (1975) 35) C.H. Miller, "Improved Delay and Igniferous Compositions", 3rd *SympChemProblConnectedStab-Expls(Proc)*, **1973**, 285-301 (Pub 1974) & *CA* **82**, 142273 (1975) 36) P.L. Farnell & A.J. Beardell, "Ignitability of Energetic Compositions in the Presence of Flammable Liquids", 8th *Proc-SympExplos&Pyrots*, No 32 (1974) & *CA* **82**, 75140 (1975) 37) T. Boddington et al, "Study of Pyrotechnic Reactions by Temperature Profile Analysis and Differential Thermal Analysis", *Combustn&Flame* **24** (1), 137-38 (1975) & *CA* **83**, 30450 (1975) 38) A.G. Merzhanov, "Thermal Theory of Metal Particle Ignition", *AIAAJ* **13** (2), 209-14 (1975) & *CA* **82**, 158344 (1975) 39) G. Stetter et al, "Pyrotechnic Radiator", *CanP* 951961 (1974) & *CA* **82**, 178090 (1975) 40) R.C. Harris, "Compatibility and Stability Problems Associated with Pyrotechnics, Progress 1970-73", 3rd *SympChemProblConnectedStabExpls(Proc)*, **1973**, 275-84 (Publ 1974) & *CA* **82**, 142272 (1975) 41) Anon, "Timing Systems and Components", **AMCP 706-205** (1975) 21-3 ff 42) Bretherick (1975), 78, 214 & 951-52 43) D.E. Jensen & B.C. Webb, "Afterburning Predictions for Metal-Modified Propellant Motor Exhausts", *AIAA J* **14** (7),

- 947-54 (1976) & CA 85, 126781 (1976)
- 44) R. Rion & G. Dupont, "Electric Detonator. Part III. Explosive System", *Explosifs* 29 (1-2), 3-12 (1976) & CA 85, 126782 (1976)
- 45) Merck (1976), 1258 (No 9468) 46) E.L. Charsley & D.E. Tolhurst, "Application of Hot Stage Microscopy to the Study of Pyrotechnic Systems", *Microscope* 23 (4), 227-37 (1975) & CA 84, 92344 (1976) 47) E.L. Charsley & P.G. Laye, "Thermal Studies on Pyrotechnic Delay Compositions", *JCalmitricAnalTherm* 3-1, (4) (1976) & CA 86, 192030 (1977) 48) Ibid, "Differential Thermal Analysis and Temperature Profile Analysis Studies on Pyrotechnic Delay Compositions", 1st ProcEurSympThermAnal, 446-47 (1976) & CA 87, 87214 (1977)
- 49) W.D. Wilkinson, "Tungsten", McGraw-Hill Encycl Sci & Technol, Vol 14, NY (1977), 153-60 50) CondChemDict (1977), 868
- 51) E.L. Charsley & D.E. Tolhurst, "The Application of Hot Stage Microscopy to the Study of Pyrotechnic Systems", 4th ThermAnalProcIntl-Conf 1974, 3, 75-86 (Publ 1975) & CA 87, 87211 (1977) 52) E.L. Charsley et al, "Thermal Studies of Pyrotechnic Systems", *ThermochimActa* 29 (2), 349-52 (1979) & CA 90, 157990 (1979) 53) J.E. Rose, "Stability of Delay Compositions", *JHazardMaterials* 2 (2), 97-112 (1978) & CA 89, 131852 (1978)
- 54) E.L. Charsley & P.G. Laye, "Thermal Studies on Pyrotechnic Delay Compositions", *JCalorim-AnalTherm* 7, 3/1/1-3/1/4 (1976) & CA 88, 91779 (1978) 55) Anon, CRC Hndbk Chem & Phys (1978), B-172 56) E.L. Charsley et al, "Differential Thermal Analysis . . . Mixtures of Tungsten and Potassium Dichromate", *ThermochimActa* 25 (2), 131-41 (1978) & CA 89, 165635 (1978) 57) Anon, "Fire Protection Guide on Hazardous Materials-7th Edition", Natl Fire Protection Assn, Boston (1978), 491M-434 58) G. Gaudin, "Application of Molded Plastic Explosives . . . Effects of Constituents on the Detonation Swiftness of Composite Explosives", *IntJohrestagInstChemTreibExplosivst*, 243-54 (1978) & CA 91, 93838 (1979)
- 59) R. Pruemmer, "Explosive Pressing of Metallic and Ceramic Powders and their Mixtures", *PoroshkMetall(Minsk)* 1, 14-22 (1977) & CA 91, 43054 (1979) 59a) M. Gilford & F.J. Taylor, "Reaction Mechanism Governing Tungsten-Barium Chromate-Potassium Perchlorate Delay System", ADPA Mtg Presentation, West Point (7-9 Nov (1979) 59b) E.L. Charsley et al, "Thermal Studies of Pyrotechnic Systems", *ThermochimActa* 29 (2), 349-52 (1979) & CA 90, 157990 (1979) 60) H. Nakamura et al, "The Thermal Reactivity of Tungsten-Potassium Perchlorate-Barium Chromate Delay Compositions", *KogyoKayaku* 40 (1), 31-37 (1979) & CA 91, 23446 (1979) 61) R.T. Sedgwick & H.R. Katz, "Fuel Air Explosives in a Parametric Investigation", 10th ProcSympExpls&Pyrots, Paper No 22 (1979) & CA 92, 8492 (1980) 62) D.H. Brooks & F.J. Valenta, "Pyrotechnic Delay Cutters for More Severe Acceleration and Temperature Environments", 10th ProcSymp-Expls&Pyrots, Paper No 12 (1979) & CA 92, 8485 (1980)
- Addnl (Limited Distribution) Refs:* A) F.J. Valenta, "Effects of Pressure on Burning Rates of Manganese and Tungsten Delay Compositions", *IHTR* 315, NAVORD, Indian Head (1970) (Limited Dist) B) J.E. Rose, "Burning Time Extension in Tungsten Delay Compositions with Ceric Oxide and Vanadium Pentoxide Flame Sustainers", *IHTR* 330, NAVORD, Indian Head (1970) (Limited Dist) C) R. Zimmer-Galler, "The Combustion of Tungsten and Manganese Delay Systems", *IHMR* 70-110, NAVORD, Indian Head (1970) (Limited Dist) D) F.J. Valenta, "Some Factors Affecting Burning Rates and Variability of Tungsten and Manganese Delay Compositions", *IHTR* 355, NAVORD, Indian Head (1972) (Limited Dist)

Tungsten Dioxide. See in Vol 8, O52-R

Tunnel-Gelatin 90-80%. Trade names of AN-NG-based gelatinous expls distributed in the UK by I.C.I.:

	Density, g/cc	Weight Strength, %
Tunnel-Gelatin 90	1.45	89
Tunnel-Gelatin 80	1.43	85

Ref: R. Meyer, "Explosives", Verlag Chemie, NY (1977), 243

Tunnelit. Russ pre-WWI blasting expl contg Dinitrochlorohydrin 20, Trinitroglycerin 5,

Mononitrotoluene 10, Collodion cotton 1, Amm nitrate 52.5, Na nitrate 9 and a carbohydrate 2.5%

Ref: Anon, SS 12, 410 (1917)

Turmeric Powder Explosives. Several expls patented by Ceipek contain nitrated tumeric powder (Indian saffron), eg, AN 82, nitrated turmeric powder 4, TNT 10, and gelatin 4% (composed of DNT 3.83 & NC 0.17%)

Refs: N. Ceipek, BritP 9743 (1911) & CA 7 703 (1913), BritP 13549 (1911) & CA 6, 3525 (1912)

Turpentine, Nitrated. Prepn of this compd and its use in expl compns was patented in 1886 by Schultze. It was prepd by gradually adding nitric acid (d 1.42 to 1.46g/cc) to stirred turpentine. A typical formulation contained Nitrated turpentine 15, NC 10 and K nitrate 75p, to which was added 10p of S

Ref: Daniel (1902), 765

Turpin's Explosives and Propellants. See under "Explosifs et Poudres de Turpin" and "Pyrodialytes" in Vol 6, E366-L to E367-R

Turpinite. An expl used by the Fr during WWI for loading shell. It supposedly developed a

deadly poison gas on functioning. No compn is given

Ref: R. Hauslian, "Der Chemische Krieg", Mittler & Sohn, Berlin (1937), 12-13

Tuthilote. A Brit permissible expl which passed the Buxton test: AN 60, TNT 14, Ca silicide 1, Na chloride 25%; BalPend test 2.45"

Ref: Marshall 3, 119 (1932)

Tutol. A Brit permissible expl which passed the Woolwich test: NG 25, K nitrate 33, Ba nitrate 2, woodmeal 40%, with Na bicarbonate 0.25% added

Ref: Marshall 1, 375 (1917)

Two-Step Explosive Shell. A projectile designed to expld in two steps when striking two successive obstacles

Ref: W. Weiss, USP 2806428 (1957)

Tyne (Afror) Powder. See "Afror Tyne Powder" in Vol 1, A109-L

"Type" Explosives. See under "Japanese Explosives, Ammunition & Weapons" in Vol 7, J56-L to J57-R